

DS8005

Smart Card Interface

General Description

The DS8005 dual smart card interface is a low-cost, dual analog front-end for an IC card reader interface that needs to communicate with two smart cards in a mutually exclusive fashion. The analog interface is designed for use in ISO 7816, EMV®, and B-CAS applications. The device is functionally similar to two DS8024s with external multiplexing to select the active interface, but also includes low power and 1.8V card support. Additionally, the device is designed for applications where the C4/C8 (AUX1/AUX2) contacts are not required on either card interface.

The device is provided in 28-pin SO and TSSOP packages. The pinout is backwards compatible with the DS8313, allowing applications to use the same footprint and PCB for applications that communicate with either one or two smart cards.

The device is designed to be used with microcontrollers that contain an ISO 7816 UART, or have the bandwidth to run this protocol in software by bit-banging IO ports. If the microcontroller does not have the capability of running the ISO 7816 UART, the DS8007 is the more appropriate product selection.

Applications

- Set-Top Box Conditional Access
- Telecommunications
- Pay Television
- Access Control
- Financial Terminals

Ordering Information

PART	CARD VOLTAGES SUPPORTED	LOW POWER STOP MODE	LOW POWER ACTIVE MODE	PRES_POLARITY	TEMP RANGE	PIN-PACKAGE
DS8005-RRX+	1.8V, 3V, 5V	Yes	Yes	Positive	-40°C to +85°C	28 SO
DS8005-RJX+	1.8V, 3V, 5V	Yes	Yes	Positive	-40°C to +85°C	28 TSSOP

+Denotes lead(Pb)-free/RoHS-compliant package.

Typical Application Circuit appears at end of data sheet.

EMV is a registered trademark of EMVCo LLC.

Note: Some revisions of this device may incorporate deviations from published specifications known as errata. Multiple revisions of any device may be simultaneously available through various sales channels. For information about device errata, go to: www.maximintegrated.com/errata.

Features

- Analog Interface and Level Shifting for IC Card Communication
- $\pm 8\text{kV}$ (min) ESD (HBM) Protection on Card Interfaces
- Ultra-Low Stop-Mode Current, Less than 10nA Typical
- Internal IC Card Supply-Voltage Generation
 - 5.0V $\pm 5\%$, 80mA (max)
 - 3.0V $\pm 8\%$, 65mA (max)
 - 1.8V $\pm 10\%$, 30mA (max)
- Automatic Card Activation and Deactivation Controlled by Dedicated Internal Sequencer
- I/O Lines from Host Directly Level Shifted for Smart Card Communication
- Flexible Card Clock Generation, Supporting External Crystal Frequency Divided by 1, 2, 4, or 8
- High-Current, Short-Circuit and High-Temperature Protection
- Low Active-Mode Current
- Internal Multiplexing Allows One ISO 7816 UART
- Implementation to Control Two Smart Card Sockets

Absolute Maximum Ratings

Voltage Range on V _{DD} Relative to GND.....	-0.5V to +6.5V	Maximum Junction Temperature.....	+125°C
Voltage Range on V _{DDA} Relative to GND.....	-0.5V to +6.5V	Maximum Power Dissipation Range (T _A = -25°C to +85°C).....	700mW
Voltage Range on CLKA, RSTA, I/OA.....	-0.5V to (V _{CCA} + 0.5V)	Storage Temperature Range.....	-55°C to +150°C
Voltage Range on CLKB, RSTB, I/OB.....	-0.5V to (V _{CCB} + 0.5V)	Lead Temperature (soldering, 10s).....	+300°C
Voltage Range on All Other Pins Relative to GND.....	-0.5V to (V _{DD} + 0.5V)	Soldering Temperature (reflow).....	+260°C

Stresses beyond those listed under "Absolute Maximum Ratings" may cause permanent damage to the device. These are stress ratings only, and functional operation of the device at these or any other conditions beyond those indicated in the operational sections of the specifications is not implied. Exposure to absolute maximum rating conditions for extended periods may affect device reliability.

Recommended DC Operating Conditions

(V_{DD} = +3.3V, V_{DDA} = +5.0V, T_A = +25°C, unless otherwise noted. All specifications apply to the device, unless otherwise noted in the CONDITIONS column.) (Note 1)

PARAMETER	SYMBOL	CONDITIONS	MIN	TYP	MAX	UNITS
POWER SUPPLY						
Digital Supply Voltage	V _{DD}		2.7		6.0	V
Card Voltage-Generator Supply Voltage	V _{DDA}	Must be ≥ V _{DD}	4.75		6.0	V
Reset Voltage Thresholds	V _{TH2}	Threshold voltage (falling)	2.20	2.45	2.65	V
	V _{HYS2}	Hysteresis	50	100	200	mV
CURRENT CONSUMPTION						
Active V _{DD} Current 5V Cards (Including 80mA Draw from 5V Card)	I _{DD_50V}	I _{CC} = 80mA, f _{XTAL} = 20MHz, f _{CLK} = 10MHz, V _{DDA} = 5.0V		80.75	85	mA
Active V _{DD} Current 5V Cards (Current Consumed by Device Only)	I _{DD_IC}	I _{CC} = 80mA, f _{XTAL} = 20MHz, f _{CLK} = 10MHz, V _{DDA} = 5.0V (Note 2)		0.75	5	mA
Active V _{DD} Current 3V Cards (Including 65mA Draw from 3V Card)	I _{DD_30V}	I _{CC} = 65mA, f _{XTAL} = 20MHz, f _{CLK} = 10MHz, V _{DDA} = 5.0V		65.75	70	mA
Active V _{DD} Current 3V Cards (Current Consumed by Device Only)	I _{DD_IC}	I _{CC} = 65mA, f _{XTAL} = 20MHz, f _{CLK} = 10MHz, V _{DDA} = 5.0V (Note 2)		0.75	5	mA
Active V _{DD} Current 1.8V Cards (Including 30mA Draw from 1.8V Card)	I _{DD_18V}	I _{CC} = 30mA, f _{XTAL} = 20MHz, f _{CLK} = 10MHz, V _{DDA} = 5.0V		30.75	40	mA
Active V _{DD} Current 1.8V Cards (Current Consumed by Device Only)	I _{DD_IC}	I _{CC} = 30mA, f _{XTAL} = 20MHz, f _{CLK} = 10MHz, V _{DDA} = 5.0V (Note 2)		0.75	5	mA
Inactive-Mode Current	I _{DD}	Card inactive, active-high PRES_, device not in stop mode		50	400	µA
Stop-Mode Current	I _{DD_STOP}	Device in ultra-low-power stop mode (CMDVCC, 5V/3V, and 1_8V set to logic 1) (Note 3)		0.01	2	µA

Recommended DC Operating Conditions (continued)

($V_{DD} = +3.3V$, $V_{DDA} = +5.0V$, $T_A = +25^\circ C$, unless otherwise noted. All specifications apply to the device, unless otherwise noted in the CONDITIONS column.) (Note 1)

PARAMETER		SYMBOL	CONDITIONS	MIN	TYP	MAX	UNITS
CLOCK SOURCE							
Crystal Frequency		f_{XTAL}	External crystal (Note 1)	0		20	MHz
XTAL1 Operating Conditions		f_{XTAL1}	(Note 1)	0		20	MHz
		V_{IL_XTAL1}	Low-level input on XTAL1	-0.3		$0.3 \times V_{DD}$	V
		V_{IH_XTAL1}	High-level input on XTAL1	$0.7 \times V_{DD}$		$V_{DD} + 0.3$	V
External Capacitance for Crystal		C_{XTAL1} , C_{XTAL2}				15	pF
Internal Oscillator		f_{INT}		2.2	2.7	3.4	MHz
SHUTDOWN TEMPERATURE							
Shutdown Temperature		T_{SD}			+150		$^\circ C$
RSTA AND RSTB PINS							
Card-Inactive Mode	Output Low Voltage	V_{OL_RST1}	$I_{OL_RST} = 1mA$			0.3	V
	Output Current	I_{OL_RST1}	$V_{OL_RST} = 0V$			-1	mA
Card-Active Mode	Output Low Voltage	V_{OL_RST2}	$I_{OL_RST} = 200\mu A$			0.3	V
	Output High Voltage	V_{OH_RST2}	$I_{OH_RST} = -200\mu A$	$V_{CC} - 0.5$			V
	Rise Time	t_{R_RST}	$C_L = 30pF$ (Note 1)			0.1	μs
	Fall Time	t_{F_RST}	$C_L = 30pF$ (Note 1)			0.1	μs
	Current Limitation	$I_{RST(LIMIT)}$		-20		+20	mA
	RSTIN to RST Delay	$t_{D(RSTIN-RST)}$				2	μs
CLKA AND CLKB PINS							
Card-Inactive Mode	Output Low Voltage	V_{OL_CLK1}	$I_{OLCLK} = 1mA$			0.3	V
	Output Current	I_{OL_CLK1}	$V_{OLCLK} = 0V$			-1	mA
Card-Active Mode	Output Low Voltage	V_{OL_CLK2}	$I_{OLCLK} = 200\mu A$			0.3	V
	Output High Voltage	V_{OH_CLK2}	$I_{OHCLK} = -200\mu A$	$V_{CC} - 0.5$			V
	Rise Time	t_{R_CLK}	$C_L = 30pF$ (Notes 1, 4)			8	ns
	Fall Time	t_{F_CLK}	$C_L = 30pF$ (Notes 1, 4)			8	ns
	Current Limitation	$I_{CLK(LIMIT)}$		-75		+75	mA
	Clock Frequency	f_{CLK}	Operational	0		10	MHz
	Duty Factor	δ	$C_L = 30pF$	45		55	%
	Slew Rate	SR	$C_L = 30pF$ (Note 1)	0.2			V/ns
VCCA AND VCCB PINS							
Card-Inactive Mode	Output Low Voltage	V_{CC1}	$I_{CC} = 1mA$			0.3	V
	Output Current	I_{CC1}	$V_{CC} = 0V$	0		-1	mA

Recommended DC Operating Conditions (continued)

($V_{DD} = +3.3V$, $V_{DDA} = +5.0V$, $T_A = +25^\circ C$, unless otherwise noted. All specifications apply to the device, unless otherwise noted in the CONDITIONS column.) (Note 1)

PARAMETER		SYMBOL	CONDITIONS	MIN	TYP	MAX	UNITS	
Card-Active Mode	Output Low Voltage	V_{CC2}	Device: $I_{CC(5V)} < 30mA$, $V_{DDA} = 4.75V$ (Note 1)	4.65	5	5.25	V	
			Device: $I_{CC(5V)} < 80mA$	4.75	5	5.25		
			Device: $I_{CC(3V)} < 65mA$	2.78	3	3.24		
			Device: $I_{CC(1.8V)} < 30mA$	1.64	1.8	1.98		
			5V card; current pulses of 40nC with $I < 200mA$, $t < 400ns$, $f < 20MHz$	4.6		5.4		
			3V card; current pulses of 24nC with $I < 200mA$, $t < 400ns$, $f < 20MHz$	2.75		3.25		
				1.8V card; current pulses of 12nC with $I < 200mA$, $t < 400ns$, $f < 20MHz$	1.62		1.98	
	Output Current	I_{CC2}	$V_{CC(5V)} = 0$ to 5V				-80	mA
			$V_{CC(3V)} = 0$ to 3V				-65	
			$V_{CC(1.8V)} = 0$ to 1.8V				-30	
Shutdown Current Threshold	$I_{CC(SD)}$	(Note 1)		120			mA	
Slew Rate	V_{CCSR}	Up/down; $C < 300nF$ (Note 5)	0.05	0.16	0.22		V/ μs	
DATA LINES (I/O_ AND I/OIN)								
I/O_ \square I/OIN Falling Edge Delay		$t_{D(I/O-I/OIN)}$	(Note 1)			200	ns	
Pullup Pulse Active Time		t_{PU}	(Note 1)			100	ns	
Maximum Frequency		f_{IOMAX}				1	MHz	
Input Capacitance		C_I				10	pF	
I/OA AND I/OB PINS								
Card-Inactive Mode	Output Low Voltage	V_{OL_IO1}	$I_{OL_IO} = 1mA$			0.3	V	
	Output Current	I_{OL_IO1}	$V_{OL_IO} = 0V$	0		-1	mA	
	Internal Pullup Resistor	R_{PU_IO}	To V_{CC}	6	11	19	k Ω	
Card-Active Mode	Output Low Voltage	V_{OL_IO2}	$I_{OL_IO} = 1mA$			0.3	V	
	Output High Voltage	V_{OH_IO2}	$I_{OH_IO} = < -20\mu A$			$0.8 \times V_{CC}$	V	
			$I_{OH_IO} = < -40\mu A$ (3V/5V)			$0.75 \times V_{CC}$		
	Output Rise/Fall Time	t_{OT}	$C_L = 30pF$ (Note 1)			0.1	μs	
	Input Low Voltage	V_{IL_IO}			-0.3		+0.8	V
Input High Voltage	V_{IH_IO}			1.5		V_{CC}		

Recommended DC Operating Conditions (continued)

($V_{DD} = +3.3V$, $V_{DDA} = +5.0V$, $T_A = +25^\circ C$, unless otherwise noted. All specifications apply to the device, unless otherwise noted in the CONDITIONS column.) (Note 1)

PARAMETER		SYMBOL	CONDITIONS	MIN	TYP	MAX	UNITS
Card-Active Mode	Input Low Current	I_{IL_IO}	$V_{IL_IO} = 0V$			700	μA
	Input High Current	I_{IH_IO}	$V_{IH_IO} = V_{CC}$	-20		+20	μA
	Input Rise/Fall Time	t_{IT}				1.2	μs
	Current Limitation	$I_{IO(LIMIT)}$	$C_L = 30pF$	-15		+15	mA
I/OIN PIN							
Output Low Voltage		V_{OL}	$I_{OL} = 1mA$			0.3	V
Output High Voltage		V_{OH}	$I_{OH} < -40\mu A$	$0.75 \times V_{DD}$		$V_{DD} + 0.1$	V
Output Rise/Fall Time		t_{OT}	$C_L = 30pF$, 10% to 90%			0.1	μs
Input Low Voltage		V_{IL}		-0.3		$+0.3 \times V_{DD}$	V
Input High Voltage		V_{IH}		$0.7 \times V_{DD}$		$V_{DD} + 0.3$	V
Input Low Current		I_{IL_IO}	$V_{IL} = 0V$			700	μA
Input High Current		I_{IH_IO}	$V_{IH} = V_{DD}$	-10		+10	μA
Input Rise/Fall Time		t_{IT}	V_{IL} to V_{IH}			1.2	μs
Integrated Pullup Resistor		R_{PU}	Pullup to V_{DD}	6	11	19	k Ω
CONTROL PINS (CLKDIV1, CLKDIV2, CMDVCC, RSTIN, 5V/3V, 1_8V)							
Input Low Voltage		V_{IL}		-0.3		$+0.3 \times V_{DD}$	V
Input High Voltage		V_{IH}		$0.7 \times V_{DD}$		$V_{DD} + 0.3$	V
Input Low Current		I_{IL_IO}	$0 < V_{IL} < V_{DD}$	-5		+5	μA
Input High Current		I_{IH_IO}	$0 < V_{IH} < V_{DD}$	-5		+5	μA
INTERRUPT OUTPUT PINS (OFF AND OFF2)							
Output Low Voltage		V_{OL}	$I_{OL} = 2mA$			0.3	V
Output High Voltage		V_{OH}	$I_{OH} = -15\mu A$	$0.75 \times V_{DD}$			V
Integrated Pullup Resistor		R_{PU}	Pullup to V_{DD}	12	24	38	k Ω
PRESA AND PRESB PINS							
Input Low Voltage		V_{IL_PRES}				$0.3 \times V_{DD}$	V
Input High Voltage		V_{IH_PRES}		$0.7 \times V_{DD}$			V
Input Low Current		I_{IL_PRES}	$V_{IL_PRES} = 0V$	-5		+5	μA
Input High Current		I_{IH_PRES}	$V_{IH_PRES} = V_{DD}$			10	μA

Recommended DC Operating Conditions (continued)

($V_{DD} = +3.3V$, $V_{DDA} = +5.0V$, $T_A = +25^\circ C$, unless otherwise noted. All specifications apply to the device, unless otherwise noted in the CONDITIONS column.) (Note 1)

PARAMETER		SYMBOL	CONDITIONS	MIN	TYP	MAX	UNITS
TIMING							
Activation Time		t_{ACT}		50	160	220	μs
Deactivation Time		t_{DEACT}		50	80	100	μs
CLK_ to Card Start Time	Window Start	t_3		50	95	130	μs
	Window End	t_5		140	160	220	
PRES Debounce Time		$t_{DEBOUNCE}$		5	8	11	ms

Note 1: Operation guaranteed at $-40^\circ C$ and $+85^\circ C$ but not tested.

Note 2: I_{DD_IC} measures the amount of current used by the device to provide the smart card current minus the load.

Note 3: Stop mode is enabled by setting \overline{CMDVCC} , $5V/3V$, and 1_8V to a logic-high.

Note 4: Parameters are guaranteed to meet all ISO 7816, GSM11-11, and EMV 2000 requirements. For the 1.8V card, the maximum rise and fall time is 10ns.

Note 5: Parameter is guaranteed to meet all ISO 7816, GSM11-11, and EMV 2000 requirements. For the 1.8V card, the minimum slew rate is $0.05V/\mu s$ and the maximum slew rate is $0.5V/\mu s$.

Pin Configuration

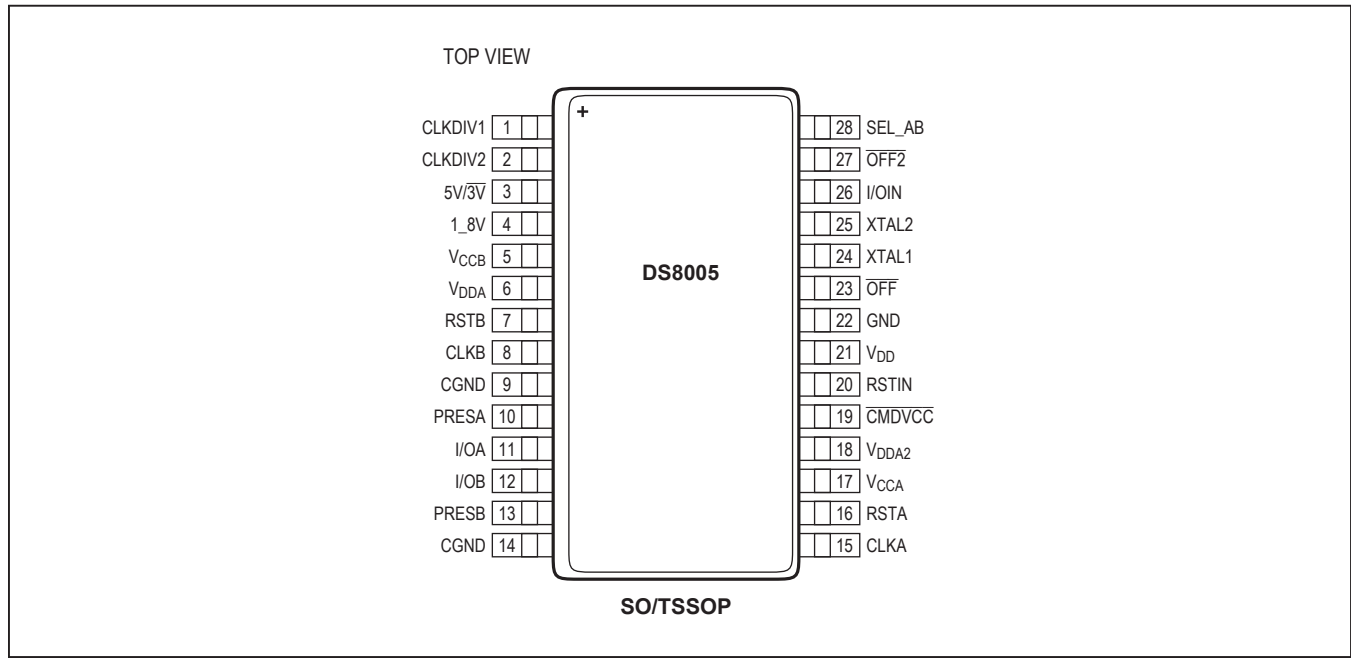

Pin Description

PIN	NAME	FUNCTION
1, 2	CLKDIV1, CLKDIV2	Clock Divider. Determines the divided-down input clock frequency (presented at XTAL1 or from a crystal at XTAL1 and XTAL2) on the CLK_ output pin. Dividers of 1, 2, 4, and 8 are available.
3	5V/3V	5V/3V Selection Pin. Allows selection of 5V or 3V for communication with an IC card. Logic-high selects 5V operation; logic-low selects 3V operation. The 1_8V pin overrides the setting on this pin if active. See Table 3 for a complete description of choosing card voltages.
4	1_8V	1.8V Operation Selection. This active-high input puts the device into 1.8V smart card communication mode. The selected interface (when activated) powers a card with a 1.8V supply and all I/O lines operate at 1.8V.
5	V _{CCB}	Smart Card Supply Voltage, Interface B. Decouple to CGND (card ground) with 2 x 100nF or 100 + 200nF capacitors (ESR < 100mΩ).
6	V _{DDA}	Smart Card Interface Supply. Connect to a 5V power supply to support 1.8V, 3.0V, and 5.0V cards. If V _{DD} ≥ 4.9V, this pin can be connected directly to V _{DD} . Decouple this pin to GND using 100nF and 10μF capacitors.
7	RSTB	Smart Card Reset, Interface B. Card reset output from contact C2.
8	CLKB	Smart Card Clock, Interface B. Card clock, contact C3.
9, 14	CGND	Smart Card Ground
10	PRESA	Interface A Card Presence Indicator. Active-high card presence input for the first card interface. When the presence indicator becomes active, a debounce timeout begins. After 8ms (typ), the OFF signal becomes active if the first card interface is selected (SEL_AB low), else the OFF2 signal becomes active.

Pin Description (continued)

PIN	NAME	FUNCTION
11	I/OA	Smart Card Data-Line Output, Interface A. Card data communication line, contact C7. This pin is only active if the first card interface is selected (SEL_AB low) and the interface has gone through an activation sequence.
12	I/OB	Smart Card Data-Line Output, Interface B. Card data communication line, contact C7. This pin is only active if the second card interface is selected (SEL_AB high) and the interface has gone through an activation sequence.
13	PRESB	Interface B Card Presence Indicator. Active-high card presence input for the second card interface. When the presence indicator becomes active, a debounce timeout begins. After 8ms (typ), the $\overline{\text{OFF}}$ signal becomes active if the second card interface is selected (SEL_AB high), else the $\overline{\text{OFF2}}$ signal becomes active.
15	CLKA	Smart Card Clock, Interface A. Card clock, contact C3.
16	RSTA	Smart Card Reset, Interface A. Card reset output from contact C2.
17	V _{CCA}	Smart Card Supply Voltage, Interface A. Decouple to CGND (card ground) with 2 x 100nF or 100 + 220nF capacitors (ESR < 100mΩ).
18	V _{DDA2}	Smart Card Interface Supply. Connect to a 5V power supply to support 1.8V, 3.0V, and 5.0V cards. If V _{DD} ≥ 4.9V, this pin can be connected directly to V _{DD} . Decouple this pin to GND using 100nF and 10μF capacitors.
19	$\overline{\text{CMDVCC}}$	Activation Sequence Initiate. Active-low input from host.
20	RSTIN	Card Reset Input. Reset input from the host.
21	V _{DD}	Supply Voltage
22	GND	Digital Ground
23	$\overline{\text{OFF}}$	Status Output for Selected Interface. Active-low interrupt output to the host. Includes a 20kΩ integrated pullup resistor to V _{DD} . This pin reflects fault events and PRES_ events on the currently selected interface only (behaving as if it were a DS8024 with only one interface). The $\overline{\text{OFF2}}$ pin should be used to monitor presence events on the nonselected interface.
24, 25	XTAL1, XTAL2	Crystal/Clock Input. Connect an input from an external clock to XTAL1 or connect a crystal across XTAL1 and XTAL2. Leave XTAL2 disconnected if driving XTAL1 from an external clock source.
26	I/OIN	I/O Input. Host-to-interface chip data I/O line.
27	$\overline{\text{OFF2}}$	Status Output for Nonselected Interface. This pin passes through the presence signal for the nonselected interface. If SEL_AB is low (the A interface is selected), this pin reflects the state of the PRESB input. If SEL_AB is high (the B interface is selected), this pin reflects the state of the PRESA input.
28	SEL_AB	Interface Selection. This pin selects the interface the input pins (I/OIN, RSTIN, etc.) communicate with and control. If SEL_AB is low, the A interface is selected. Activation sequences power up V _{CCA} and communication occurs with CLKA, I/OA, and RSTA. If SEL_AB is high, the B interface is selected. Both interfaces can be powered and clocking at the same time. See the <i>Switching A/B Interfaces</i> section for more information.

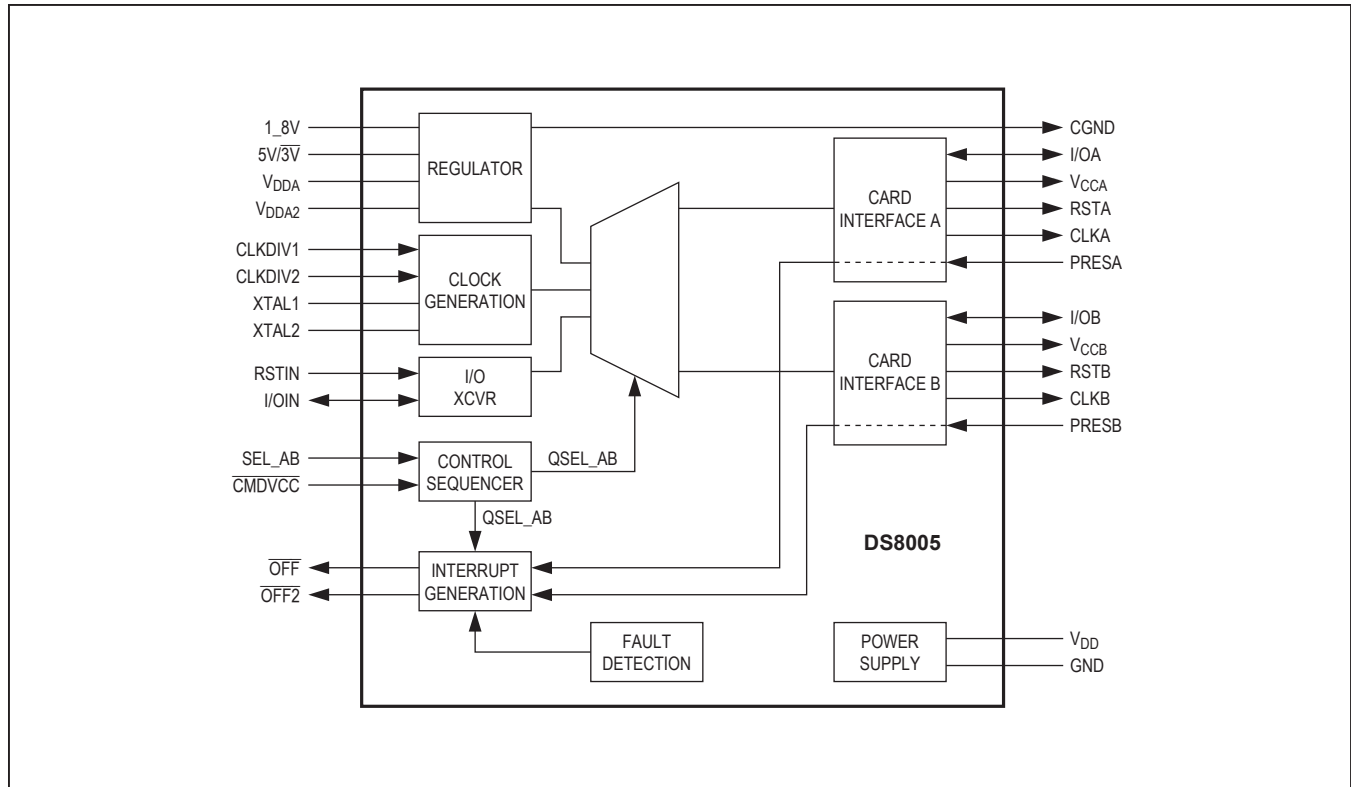

Figure 1. Functional Diagram

Detailed Description

The DS8005 is an analog front-end for communicating with 1.8V, 3V, and 5V dual smart cards. It is a dual input-voltage device, requiring one supply to match that of a host microcontroller and a separate +5V supply for generating correct smart card supply voltages. The device translates all communication lines to the correct voltage level and provides power for smart card operation. It is a low-power device, consuming very little current in active-mode operation (during a smart card communication session), and is suitable for use in battery-powered devices such as laptops and PDAs, consuming only 10nA in stop mode. The device is designed for applications that do not require communication using the C4 and C8 card contacts (AUX1 and AUX2). It is suitable for SIM/SAM interfacing, as well as for applications where only the I/O line is used to communicate with a smart card.

Power Supply

The device has dual supplies. The supply pins for the device are V_{DD} , GND, and V_{DDA} . V_{DD} should be in the 2.7V to 6.0V range, and is the supply for signals that interface with the host controller. It should, therefore, be the same supply as used by the host controller. All smart card contacts remain inactive during power-on or power-off. The internal circuits are kept in the reset state until V_{DD} reaches $V_{TH2} + V_{HYS2}$ and for the duration of the internal power-on reset pulse, t_{W} . A deactivation sequence is executed when V_{DD} falls below V_{TH2} .

An internal regulator generates the 1.8V, 3V, or 5V card supply voltage ($V_{CC_}$). The regulator should be supplied separately by V_{DDA} . V_{DDA} should be connected to a minimum 4.75V supply to provide the correct supply voltage for 5V smart cards.

Voltage Supervisor

The voltage supervisor monitors the V_{DD} supply. A 220 μ s reset pulse (t_W) is used internally to keep the device inactive during power-on or power-off of the V_{DD} supply. See Figure 2.

The IC card interface remains inactive regardless of the levels on the command lines until duration t_W after V_{DD} has reached a level higher than $V_{TH2} + V_{HYS2}$. When V_{DD} falls below V_{TH2} , the device executes a card deactivation sequence if the card interface is active.

Clock Circuitry

The card clock signal (CLKA/CLKB) is derived from a clock signal input to XTAL1 or from a crystal operating at up to 20MHz connected between XTAL1 and XTAL2. The output clock frequency of CLK_ is selectable through inputs CLKDIV1 and CLKDIV2. The CLK signal frequency can be f_{XTAL} , $f_{XTAL}/2$, $f_{XTAL}/4$, or $f_{XTAL}/8$. See Table 1 for the frequency generated on the CLK_ signal given the inputs to CLKDIV1 and CLKDIV2.

Note that CLKDIV1 and CLKDIV2 must not be changed simultaneously; a delay of 10ns minimum between changes is needed. The minimum duration of any state of CLK_ is eight periods of XTAL1.

Table 1. Clock Frequency Selection

CLKDIV1	CLKDIV2	f_{CLK}
0	0	$f_{XTAL}/8$
0	1	$f_{XTAL}/4$
1	1	$f_{XTAL}/2$
1	0	f_{XTAL}

The frequency change is synchronous: during a transition of the clock divider, no pulse is shorter than 45% of the smallest period, and the first and last clock pulses about the instant of change have the correct width. When changing the frequency dynamically, the change is effective for only eight periods of XTAL1 after the command.

The f_{XTAL} duty factor depends on the input signal on XTAL1. To reach a 45% to 55% duty factor on CLK_, XTAL1 should have a 48% to 52% duty factor with transition times less than 5% of the period.

With a crystal, the duty factor on CLK_ can be 45% to 55% depending on the circuit layout and on the crystal characteristics and frequency. In other cases, the duty factor on CLK_ is guaranteed between 45% and 55% of the clock period.

I/O Transceivers

I/O_ and I/OIN are pulled high with an 11k Ω resistor (I/O_ to V_{CC} and I/OIN to V_{DD}) in the inactive state. The first side of the transceiver to receive a falling edge becomes the master. When a falling edge is detected (and the master is decided), the detection of falling edges on the line of the other side is disabled; that side then becomes a slave. After a time delay $t_{D(EDGE)}$, an n transistor on the slave side is turned on, thus transmitting the logic 0 present on the master side.

When the master side asserts a logic 1, a p transistor on the slave side is activated during the time delay t_{PU} and then both sides return to their inactive (pulled up) states. This active pullup provides fast low-to-high transitions. After the duration of t_{PU} , the output voltage depends only on the internal pullup resistor and the load current. Current to and from the card I/O lines is limited internally to 15mA. The maximum frequency on these lines is 1MHz.

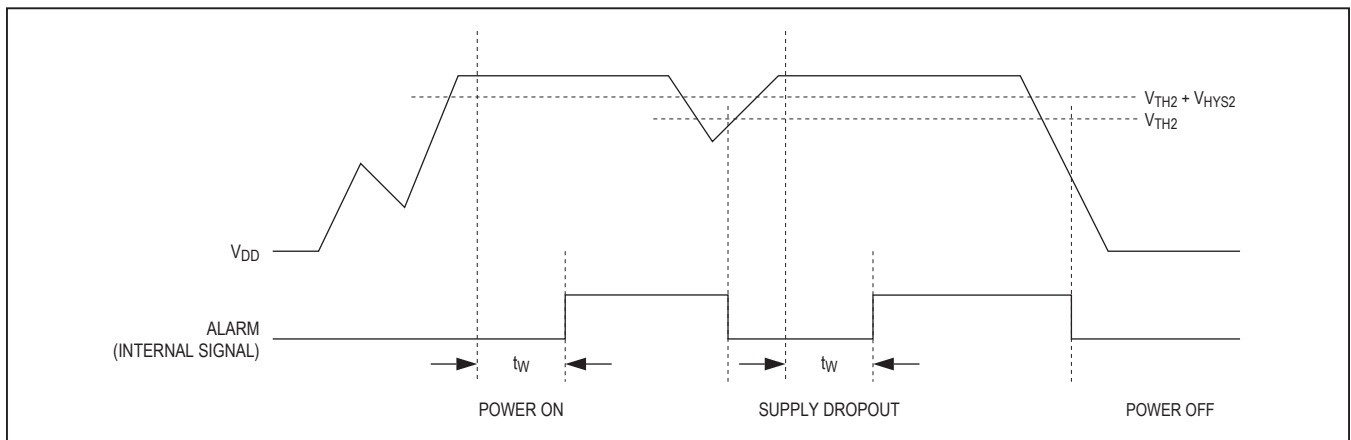

Figure 2. Voltage Supervisor Behavior

Inactive Mode

The device powers up with the card interface in the inactive mode. Minimal circuitry is active while waiting for the host to initiate a smart card session.

- All card contacts are inactive (approximately 200Ω to GND).
- The I/OIN pin in the high-impedance state (11kΩ pullup resistor to V_{DD}).
- Voltage generators are stopped.
- XTAL oscillator is running (if included in the device).
- Voltage supervisor is active.
- The internal oscillator is running at its low frequency.

Activation Sequence

After power-on and the reset delay, the host microcontroller can monitor card presence with signals $\overline{\text{OFF}}$ and $\overline{\text{CMDVCC}}$, as shown in Table 2.

If the card is in the reader (if PRES_ is active), the host microcontroller can begin an activation sequence (start a card session) by pulling $\overline{\text{CMDVCC}}$ low. The following events form an activation sequence (Figure 3):

- 1) $\overline{\text{CMDVCC}}$ is pulled low.
- 2) The internal oscillator changes to high frequency (t_0).
- 3) The voltage generator is started (between t_0 and t_1).

Table 2. Card Presence Indication

SEL_AB	$\overline{\text{OFF}}$	$\overline{\text{CMDVCC}}$	STATUS
Low	High	High	Card A present.
Low	Low	High	Card A not present.
High	High	High	Card B present.
High	Low	High	Card B not present.
SEL_AB	$\overline{\text{OFF2}}$	$\overline{\text{CMDVCC}}$	STATUS
Low	High	High	Card B present.
Low	Low	High	Card B not present.
High	High	High	Card A present.
High	Low	High	Card A not present.

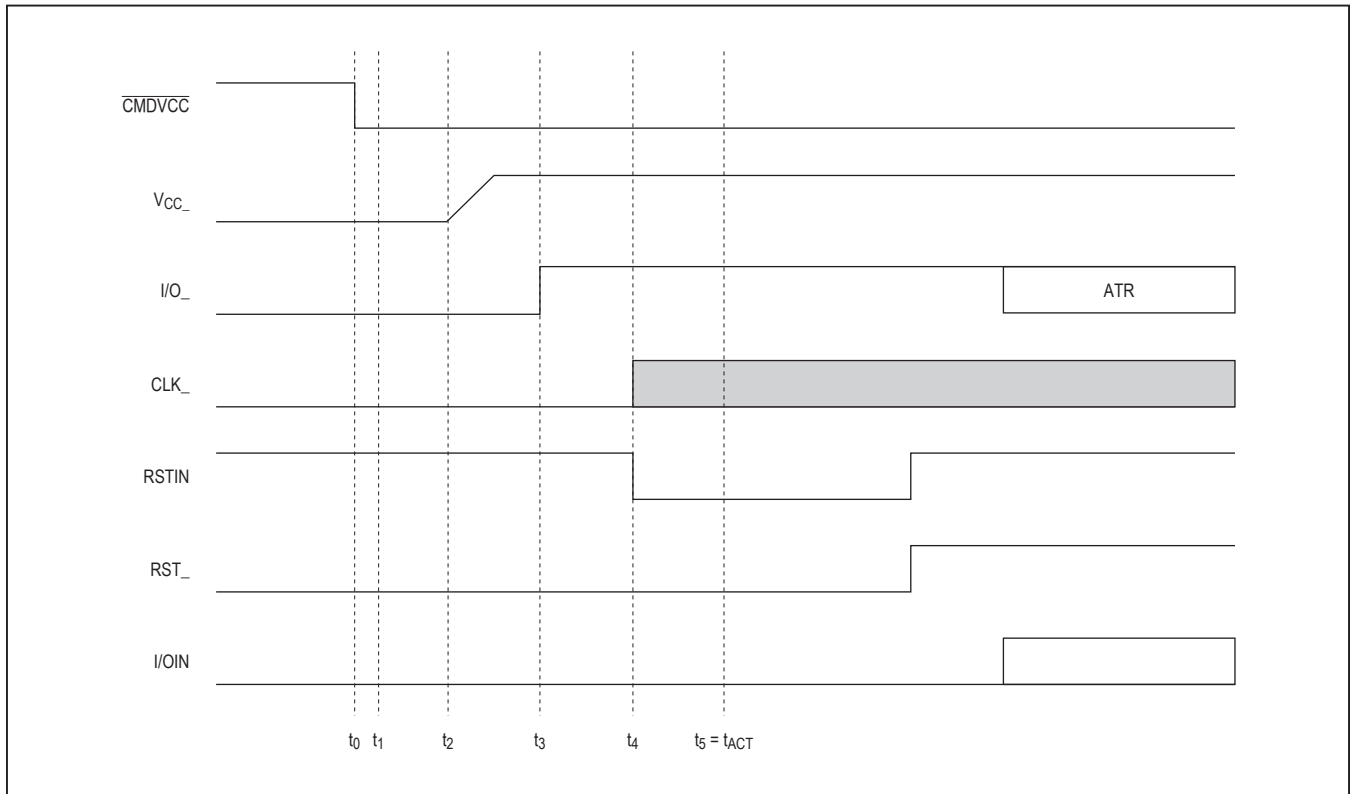

Figure 3. Activation Sequence Using RSTIN and $\overline{\text{CMDVCC}}$

- 4) $V_{CC_}$ rises from 0 to 5V, 3V, or 1.8V with a controlled slope ($t_2 = t_1 + 1.5 \times T$). T is 64 times the internal oscillator period (approximately 25 μ s).
- 5) I/O_ pin is enabled ($t_3 = t_1 + 4T$) (they were previously pulled low).
- 6) The CLK_ signal is applied to the C3 contact (t_4).
- 7) RST_ is enabled ($t_5 = t_1 + 7T$).

To apply the clock to the card interface:

- 1) Set RSTIN high.
- 2) Set \overline{CMDVCC} low.
- 3) Set RSTIN low between t_3 and t_5 ; CLK_ now starts.
- 4) RST_ stays low until t_5 , then RST becomes the copy of RSTIN.
- 5) RSTIN has no further effect on CLK_ after t_5 .

If the applied clock is not needed, set \overline{CMDVCC} low with RSTIN low. In this case, CLK_ starts at t_3 (minimum 200ns after the transition on I/O; see Figure 4); after t_5 , RSTIN can be set high to obtain an answer to request (ATR) from an inserted smart card. Do not perform activation with RSTIN held permanently high.

Active Mode

When the activation sequence is completed, the card interface is in active mode. The host microcontroller and the smart card exchange data on the I/O lines.

Deactivation Sequence

When a session is completed, the host microcontroller sets the \overline{CMDVCC} line high to execute an automatic deactivation sequence and returns the card interface to the inactive mode (Figure 5).

- 1) RST_ goes low (t_{10}).
- 2) CLK_ is held low ($t_{12} = t_{10} + 0.5 \times T$) where T is 64 times the period of the internal oscillator (approximately 25 μ s).
- 3) I/O_ pin is pulled low ($t_{13} = t_{10} + T$).
- 4) $V_{CC_}$ starts to fall ($t_{14} = t_{10} + 1.5 \times T$).
- 5) When $V_{CC_}$ reaches its inactive state, the deactivation sequence is complete (at t_{DE}).
- 6) All card contacts become low impedance to GND; I/OIN remains at V_{DD} (pulled up through an 11k Ω resistor).
- 7) The internal oscillator returns to its lower frequency.

V_{CC} Generator

Each $V_{CC_}$ generator has a capacity to supply up to 80mA continuously at 5V, 65mA at 3V, and 30mA at 1.8V.

An internal overload detector triggers at approximately 120mA. Current samples to the detector are filtered. This allows spurious current pulses (with a duration of a few μ s) up to 200mA to be drawn without causing deactivation. The average current must stay below the specified maximum current value. To maintain $V_{CC_}$ voltage accuracy, a 100nF capacitor (with an ESR < 100m Ω) should be connected to CGND and placed near the $V_{CC_}$ pin, and a 100nF or 220nF capacitor (220nF is the best choice) with the same ESR should be connected to CGND and placed near the smart card reader's C1 contact.

Fault Detection

The following fault conditions are monitored:

- Short-circuit or high current on $V_{CC_}$
- Removal of a card during a transaction
- V_{DD} dropping
- Card voltage generator operating out of the specified values (V_{DDA} too low or current consumption too high)
- Overheating

There are two different cases (Figure 6):

- **\overline{CMDVCC} High Outside a Card Session.** Output $\overline{OFF_}$ is low if a card is not in the card reader and high if a card is in the reader. The V_{DD} supply is monitored—a decrease in input voltage generates an internal power-on reset pulse but does not affect the $\overline{OFF_}$ signal. Short-circuit and temperature detection is disabled because the card is not powered up.
- **\overline{CMDVCC} Low Within a Card Session.** Output $\overline{OFF_}$ goes low when a fault condition is detected, and an emergency deactivation is performed automatically (Figure 7). When the system controller resets \overline{CMDVCC} to high, it may sense the $\overline{OFF_}$ level again after completing the deactivation sequence. This distinguishes between a card extraction and a hardware problem ($\overline{OFF_}$ goes high again if a card is present). Depending on the connector's card-present switch (normally closed or normally open) and the mechanical characteristics of the switch, bouncing can occur on the PRES_ signals at card insertion or withdrawal.

The device has a debounce feature with an 8ms typical duration (Figure 6). When a card is inserted, output $\overline{OFF_}$ goes high after the debounce time delay. When the card is extracted, an automatic deactivation sequence of the card is performed on the first true/false transition on PRES_ and output $\overline{OFF_}$ goes low.

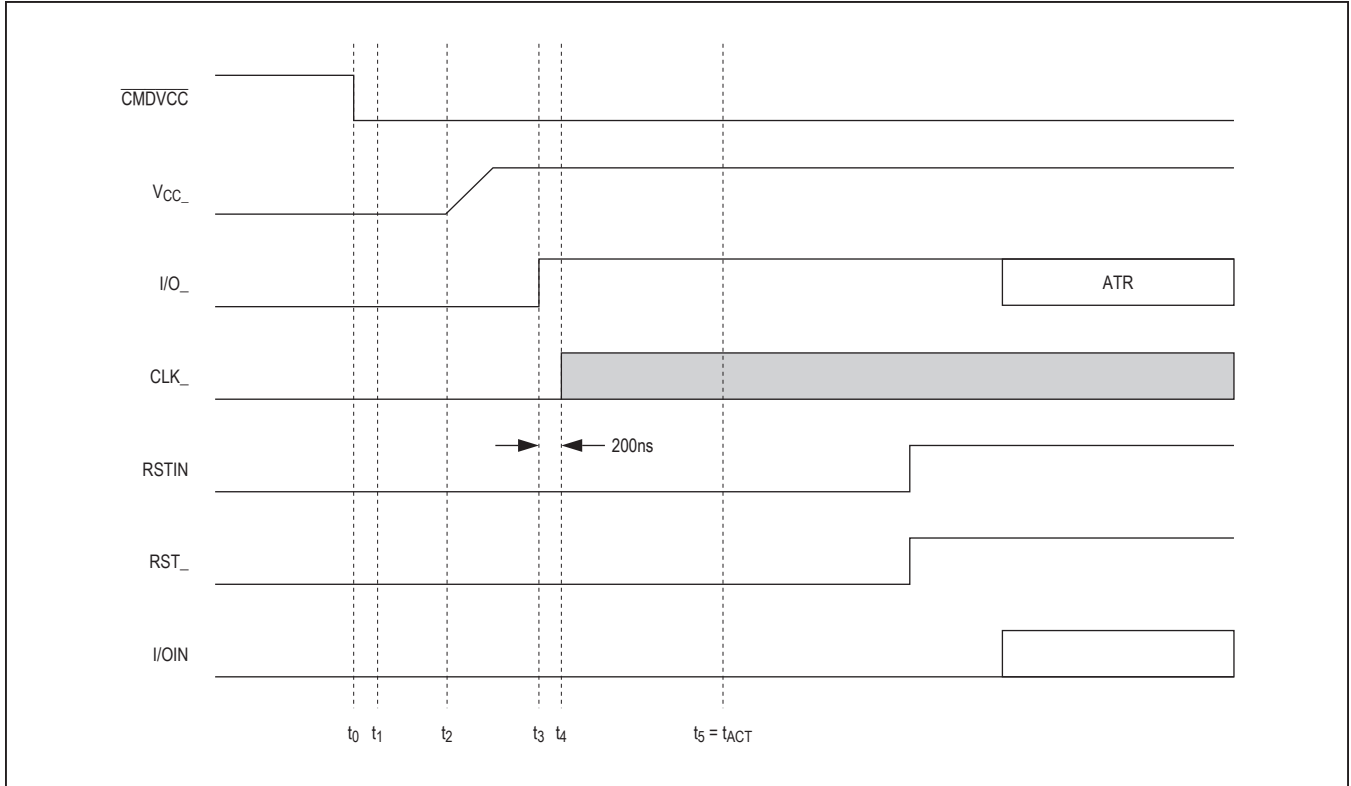

Figure 4. Activation Sequence at t_3

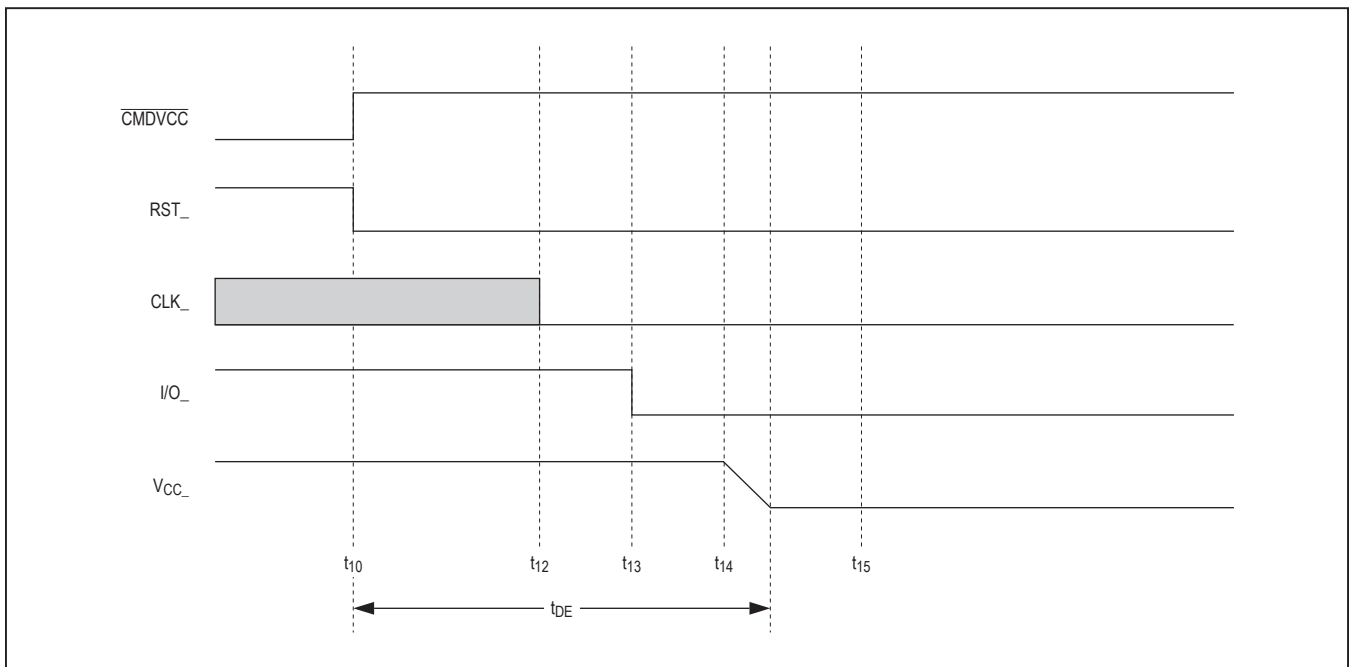

Figure 5. Deactivation Sequence

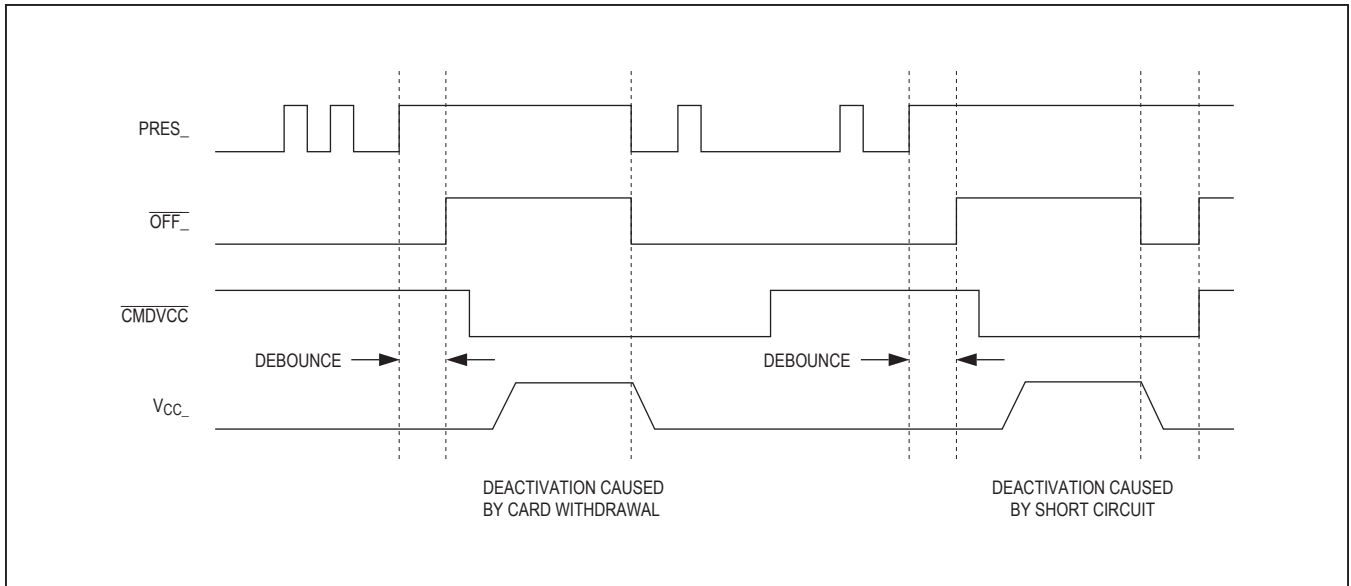

Figure 6. Behavior of PRES_, OFF_, CMDVCC, and VCC_

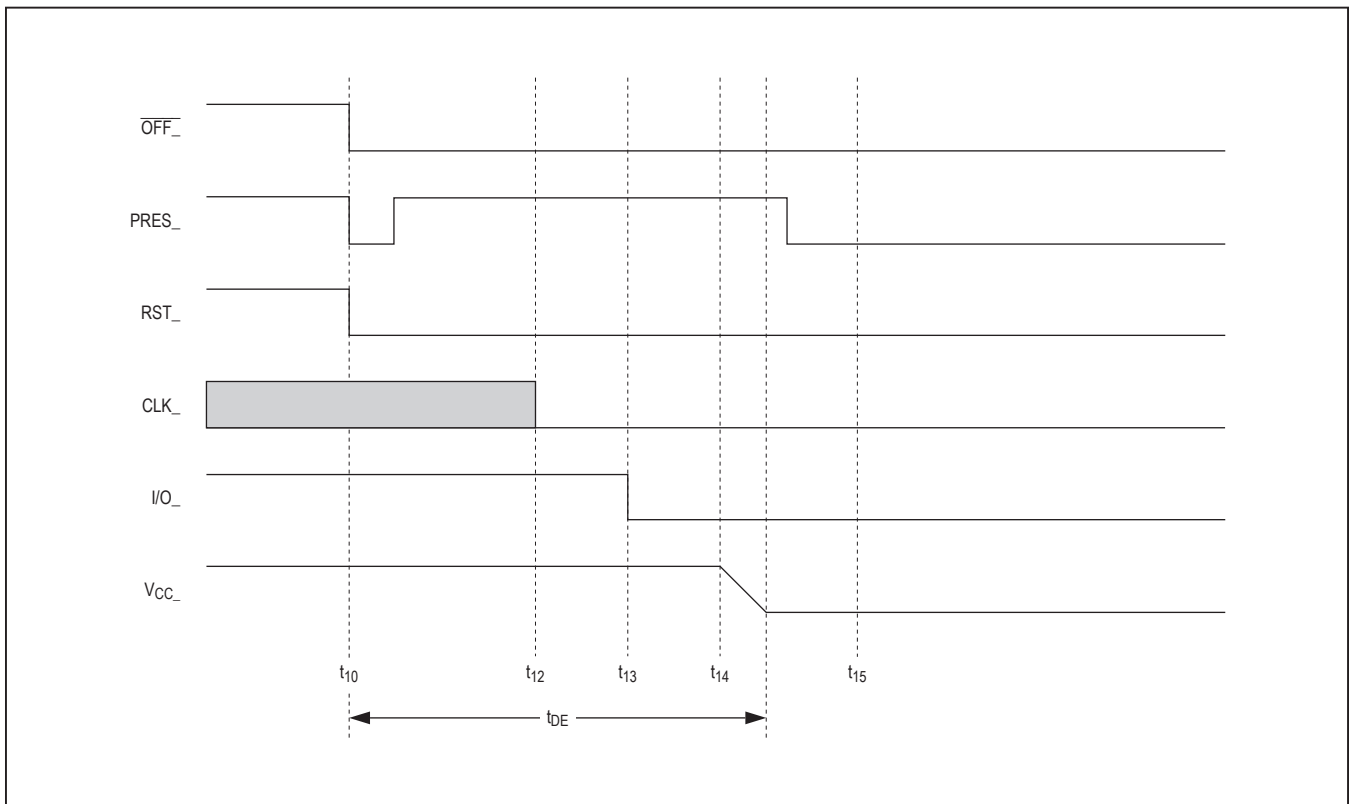

Figure 7. Emergency Deactivation Sequence (Card Extraction)

Stop Mode (Low-Power Mode)

A low-power state, stop mode, can be entered by forcing the $\overline{\text{CMDVCC}}$, $5\text{V}/3\text{V}$, and 1_8V input pins to a logic-high state. Stop mode can only be entered when the smart card interface is inactive. In stop mode, all internal analog circuits are disabled. The $\overline{\text{OFF}}$ pin follows the status of the $\text{PRES}_$ pin. To exit stop mode, change the state of one or more of the three control pins to a logic-low. An

internal $220\mu\text{s}$ (typ) power-up delay and the 8ms $\text{PRES}_$ debounce delay are in effect and $\overline{\text{OFF}}$ is asserted to allow the internal circuitry to stabilize. This prevents smart card access from occurring after leaving stop mode. Figure 8 shows the control sequence for entering and exiting stop mode. Note that an in-progress deactivation sequence always finishes before the device enters low-power stop mode.

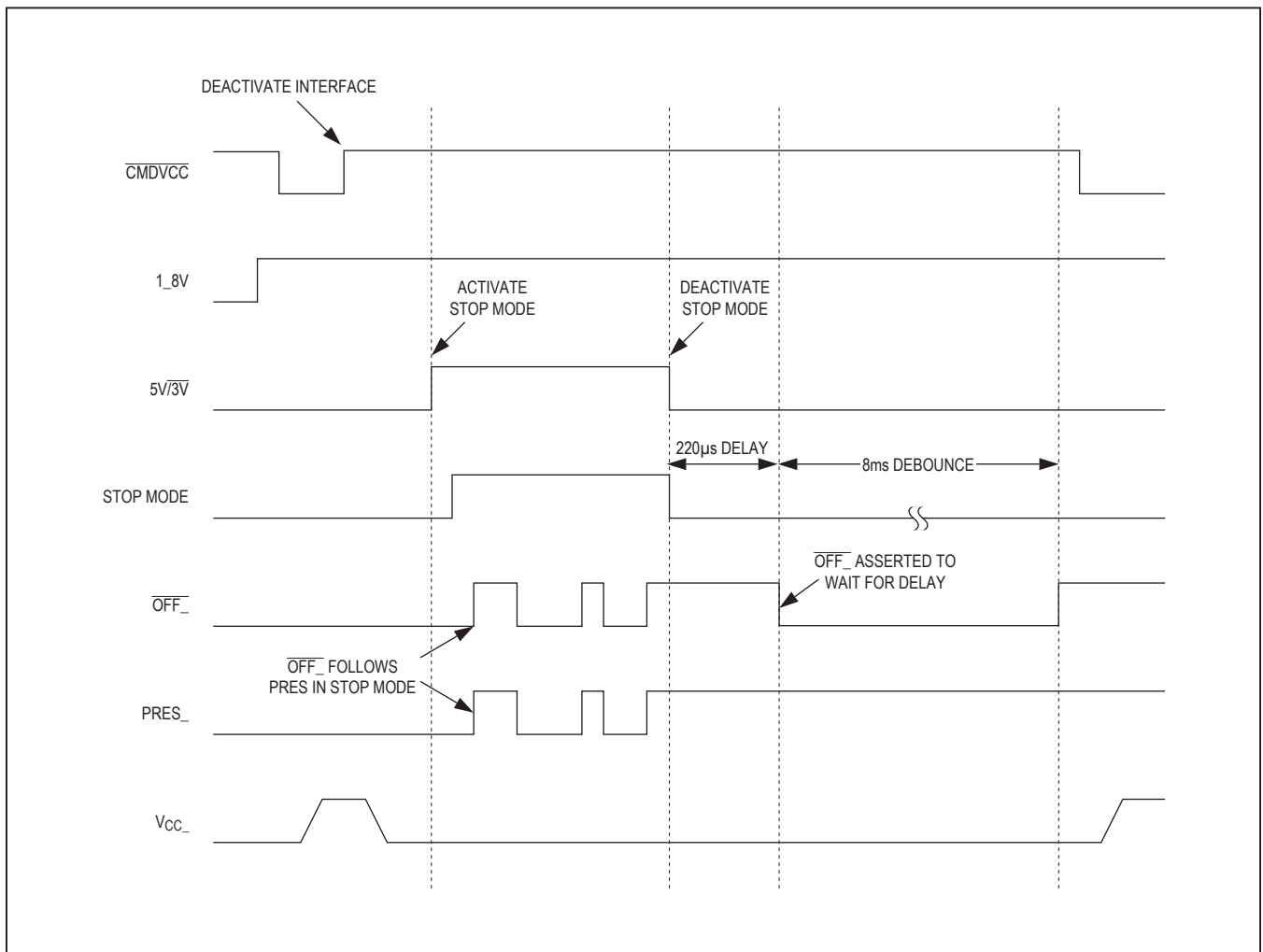

Figure 8. Stop-Mode Sequence

Smart Card Power Select

The device supports three smart card V_{CC} voltages: 1.8V, 3V, and 5V. The power select is controlled by the 1_8V and $5V/3V$ signals as shown in Table 3. The 1_8V signal has priority over $5V/3V$. When 1_8V is asserted high, 1.8V is applied to V_{CC} when the smart card is active. When 1_8V is deasserted, $5V/3V$ dictates V_{CC} power range. V_{CC} is 5V if $5V/3V$ is asserted to a logic-high state, and V_{CC} is 3V if $5V/3V$ is pulled to a logic-low state. Care

must be exercised when switching from one V_{CC} power selection to the other. If both 1_8V and $5V/3V$ are high with \overline{CMDVCC} high at the same time, the device enters stop mode. To avoid accidental entry into stop mode, the state of 1_8V and $5V/3V$ must not be changed simultaneously. A minimum delay of 100ns should be observed between changing the states of 1_8V and $5V/3V$. See Figure 9 for the recommended sequence of changing the V_{CC} range.

Table 3. V_{CC} Select and Operation Mode

1_8V	$5V/3V$	\overline{CMDVCC}	V_{CC} SELECT (V)	CARD INTERFACE STATUS
0	0	0	3	Activated
0	0	1	3	Inactivated
0	1	0	5	Activated
0	1	1	5	Inactivated
1	0	0	1.8	Activated
1	0	1	1.8	Inactivated
1	1	0	1.8	Reserved (Activated)
1	1	1	1.8	Not Applicable—Stop Mode

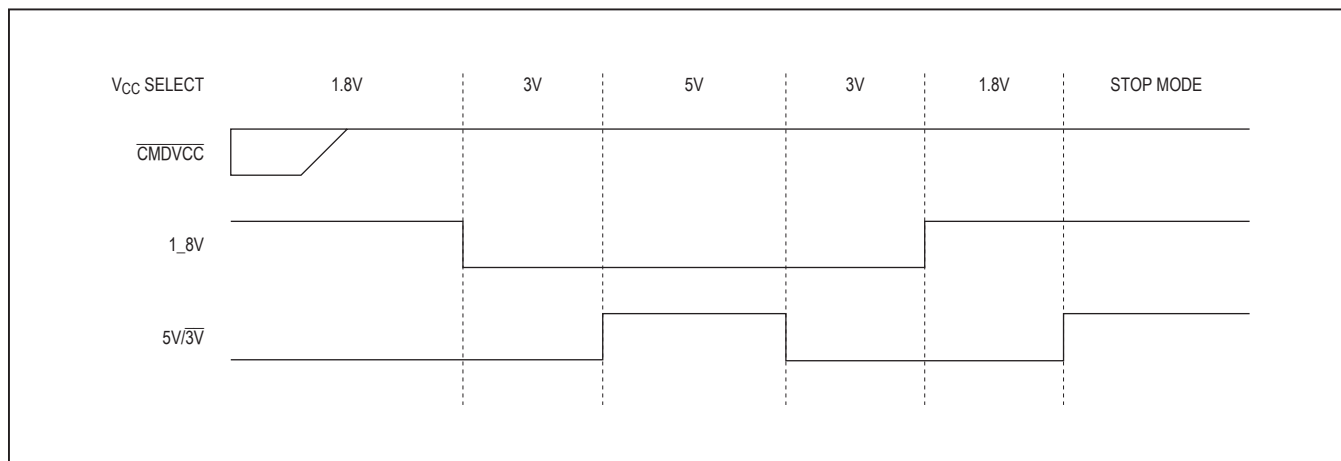

Figure 9. Smart Card Power Select

Switching A/B Interfaces

One of the device's key features is the ability to manage two card slots at the same time. The multiplexing control signal SEL_AB is used to determine which interface is active for communication, though it is possible to leave both interfaces powered at the same time.

When switching between interfaces, the device preserves the state of control signals CLKDIV1, CLKDIV2, 1.8V, 5V/3V, CMDVCC, and RSTIN by latching the pin states. This allows the now inactive interface to stay powered while the other interface is activated for communication, and it also allows for fast switching between card interfaces without the need for a card deactivation and activation

sequence. After switching SEL_AB, the control signals CLKDIV1, CLKDIV2, 1.8V, 5V/3V, CMDVCC, and RSTIN must not be changed for 78µs while the device latches the state of the pins for the inactive interface. After the control signals are latched, a 42µs window is provided to change the control inputs.

Note that the behavior of the OFF and OFF2 pins is dependent on the SEL_AB pin. OFF always refers to the active interface, and OFF2 always reports events on the inactive interface. This allows the device to monitor for card insertion and removal on both interfaces simultaneously. See Figure 10 for details on the behavior of the SEL_AB, OFF, and OFF2 pins with regard to card presence.

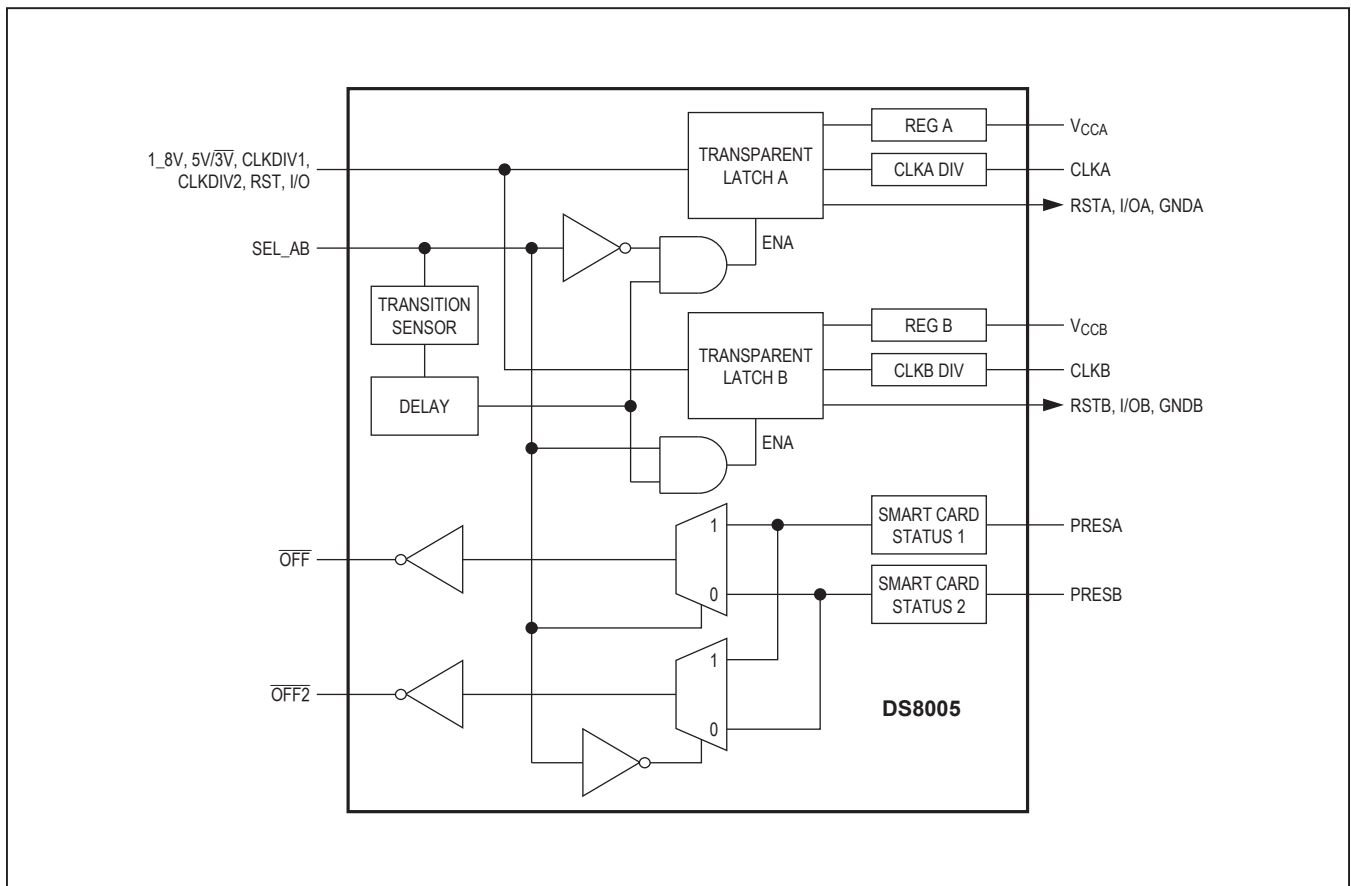

Figure 10. Switching A/B Interfaces

Applications Information

Performance can be affected by the layout of the application. For example, an additional cross-capacitance of 1pF between card reader contacts C2 (RST_) and C3 (CLK_) or C2 (RST_) and C7 (I/O_) can cause contact C2 to be polluted with high-frequency noise from C3 (or C7). In this case, include a 100pF capacitor between contacts C2 and CGND.

Application recommendations include the following:

- Ensure there is ample ground area around the device and the connector; place the device very near to the connector; decouple the V_{DD} and V_{DDA} lines separately. These lines are best positioned under the connector.
- The device and the host microcontroller must use the same V_{DD} supply. Pins CLKDIV1, CLKDIV2, RSTIN, PRES_, I/OIN, 5V/3V, 1_8V, \overline{CMDVCC} , and \overline{OFF} are referenced to V_{DD} ; if pin XTAL1 is to be driven by an external clock, also reference this pin to V_{DD} .
- Trace C3 (CLK) should be placed as far as possible from the other traces.
- The trace connecting CGND to C5 (GND) should be straight (the two capacitors on C1 (V_{CC}) should be connected to this ground trace).
- Avoid ground loops between CGND and GND.
- Decouple V_{DDA} and V_{DD} separately. If two supplies are the same in the application, they should be connected in a star on the main trace

With all these layout precautions, noise should be kept to an acceptable level and jitter on C3 (CLK_) should be less than 100ps. Reference layouts are available on request.

Technical Support

For technical support, go to <https://support.maximintegrated.com/micro>.

Typical Application Circuit

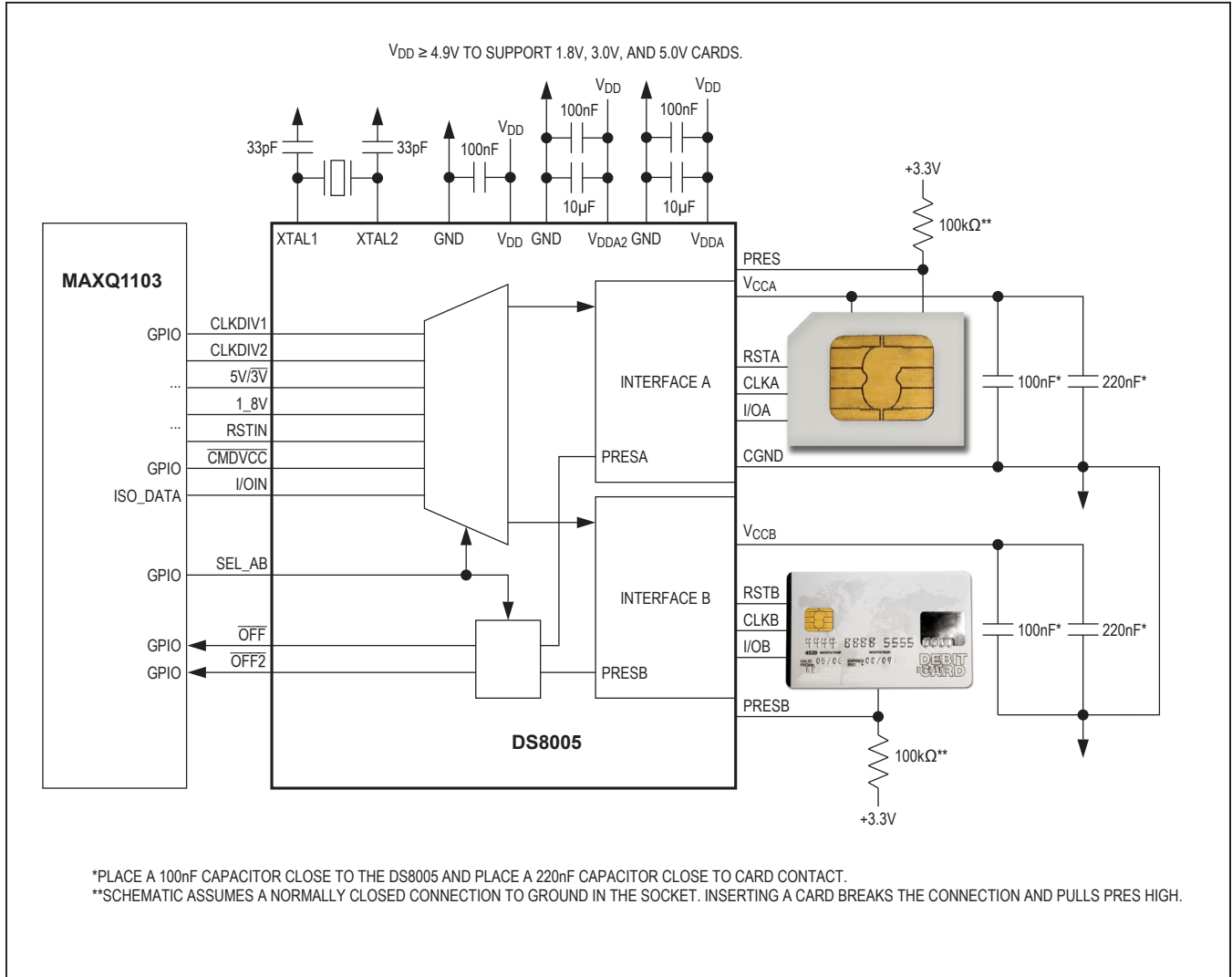

Package Information

For the latest package outline information and land patterns (footprints), go to www.maximintegrated.com/packages. Note that a "+", "#", or "-" in the package code indicates RoHS status only. Package drawings may show a different suffix character, but the drawing pertains to the package regardless of RoHS status.

PACKAGE TYPE	PACKAGE CODE	OUTLINE NO.	LAND PATTERN NO.
28 SO	W28+1	21-0042	90-0109
28 TSSOP	U28+1	21-0066	90-0171

Revision History

REVISION NUMBER	REVISION DATE	DESCRIPTION	PAGES CHANGED
0	4/10	Initial release	—
1	7/15	Added 28 TSSOP package, clarified function of V_{DDA} and V_{DDA2} pins, added V_{DDA2} pin by passing and clarified default state of PRES pins in <i>Typical Application Circuit</i>	1, 7, 8, 19

For pricing, delivery, and ordering information, please contact Maxim Direct at 1-888-629-4642, or visit Maxim Integrated's website at www.maximintegrated.com.

Maxim Integrated cannot assume responsibility for use of any circuitry other than circuitry entirely embodied in a Maxim Integrated product. No circuit patent licenses are implied. Maxim Integrated reserves the right to change the circuitry and specifications without notice at any time. The parametric values (min and max limits) shown in the Electrical Characteristics table are guaranteed. Other parametric values quoted in this data sheet are provided for guidance.



Стандарт Электрон Связь

Мы молодая и активно развивающаяся компания в области поставок электронных компонентов. Мы поставляем электронные компоненты отечественного и импортного производства напрямую от производителей и с крупнейших складов мира.

Благодаря сотрудничеству с мировыми поставщиками мы осуществляем комплексные и плановые поставки широчайшего спектра электронных компонентов.

Собственная эффективная логистика и склад в обеспечивает надежную поставку продукции в точно указанные сроки по всей России.

Мы осуществляем техническую поддержку нашим клиентам и предпродажную проверку качества продукции. На все поставляемые продукты мы предоставляем гарантию .

Осуществляем поставки продукции под контролем ВП МО РФ на предприятия военно-промышленного комплекса России , а также работаем в рамках 275 ФЗ с открытием отдельных счетов в уполномоченном банке. Система менеджмента качества компании соответствует требованиям ГОСТ ISO 9001.

Минимальные сроки поставки, гибкие цены, неограниченный ассортимент и индивидуальный подход к клиентам являются основой для выстраивания долгосрочного и эффективного сотрудничества с предприятиями радиоэлектронной промышленности, предприятиями ВПК и научно-исследовательскими институтами России.

С нами вы становитесь еще успешнее!

Наши контакты:

Телефон: +7 812 627 14 35

Электронная почта: sales@st-electron.ru

Адрес: 198099, Санкт-Петербург,
Промышленная ул, дом № 19, литера Н,
помещение 100-Н Офис 331