

FEATURES

45 ns max Propagation Delay
Single 5 V or Dual ± 15 V Supply Operation
CMOS or TTL Compatible Output
250 μ V max Input Offset Voltage
500 μ V max Input Hysteresis Voltage
15 V max Differential Input Voltage
Onboard Latch
60 mW Power Dissipation
Available in 8-Pin Plastic and Hermetic Cerdip Packages
Available in Tape and Reel in Accordance with EIA-481A Standard

APPLICATIONS

Zero-Crossing Detectors
Oversvoltage Detectors
Pulse-Width Modulators
Precision Rectifiers
Discrete A/D Converters
Delta-Sigma Modulator A/Ds

PRODUCT DESCRIPTION

The AD790 is a fast (45 ns), precise voltage comparator, with a number of features that make it exceptionally versatile and easy to use. The AD790 may operate from either a single 5 V supply or a dual ± 15 V supply. In the single-supply mode, the AD790's inputs may be referred to ground, a feature not found in other comparators. In the dual-supply mode it has the unique ability of handling a maximum differential voltage of 15 V across its input terminals, easing their interfacing to large amplitude and dynamic signals.

This device is fabricated using Analog Devices' Complementary Bipolar (CB) process—which gives the AD790's combination of fast response time and outstanding input voltage resolution (1 mV max). To preserve its speed and accuracy, the AD790 incorporates a "low glitch" output stage that does not exhibit the large current spikes normally found in TTL or CMOS output stages. Its controlled switching reduces power supply disturbances that can feed back to the input and cause undesired oscillations. The AD790 also has a latching function which makes it suitable for applications requiring synchronous operation.

The AD790 is available in five performance grades. The AD790J and the AD790K are rated over the commercial temperature range of 0°C to 70°C. The AD790A and AD790B are rated over the industrial temperature range of -40°C to +85°C. The AD790S is rated over the military temperature range of -55°C to +125°C.

REV. D

Information furnished by Analog Devices is believed to be accurate and reliable. However, no responsibility is assumed by Analog Devices for its use, nor for any infringements of patents or other rights of third parties that may result from its use. No license is granted by implication or otherwise under any patent or patent rights of Analog Devices.

CONNECTION DIAGRAMS

8-Pin Plastic Mini-DIP (N) and Cerdip (Q) Packages



8-Pin SOIC (R) Package



PRODUCT HIGHLIGHTS

1. The AD790's combination of speed, precision, versatility and low cost makes it suitable as a general purpose comparator in analog signal processing and data acquisition systems.
2. Built-in hysteresis and a low-glitch output stage minimize the chance of unwanted oscillations, making the AD790 easier to use than standard open-loop comparators.
3. The hysteresis combined with a wide input voltage range enables the AD790 to respond to both slow, low level (e.g., 10 mV) signals and fast, large amplitude (e.g., 10 V) signals.
4. A wide variety of supply voltages is acceptable for operation of the AD790, ranging from single 5 V to dual +5 V/-12 V, ± 5 V, or +5 V/ ± 15 V supplies.
5. The AD790's power dissipation is the lowest of any comparator in its speed range.
6. The AD790's output swing is symmetric between V_{LOGIC} and ground, thus providing a predictable output under a wide range of input and output conditions.

AD790—SPECIFICATIONS

DUAL SUPPLY (Operation @ 25°C and +V_S = 15 V, -V_S = -15 V, V_{LOGIC} = 5 V unless otherwise noted.)

| Parameter | Conditions | AD790J/A | | | AD790K/B | | | AD790S | | | Unit |
|--|--|-----------------|--------------|----------------------|-----------------|--------------|----------------------|-----------------|--------------|----------------------|-------------|
| | | Min | Typ | Max | Min | Typ | Max | Min | Typ | Max | |
| RESPONSE CHARACTERISTIC Propagation Delay, t _{PD} | 100 mV Step 5 mV Overdrive T _{MIN} to T _{MAX} | | 40 | 45 45/50 | | 40 | 45 45/50 | | 40 | 45 60 | ns ns |
| OUTPUT CHARACTERISTICS Output HIGH Voltage, V _{OH} | 1.6 mA Source 6.4 mA Source T _{MIN} to T _{MAX} | | 4.65 4.45 | | | 4.65 4.45 | | | 4.65 4.45 | | V V |
| Output LOW Voltage, V _{OL} | 1.6 mA Sink 6.4 mA Sink T _{MIN} to T _{MAX} | | 0.35 0.44 | 0.5 0.5/0.5 | | 0.35 0.44 | 0.5 0.5 | | 0.35 0.44 | 0.5 0.5 | V V V |
| INPUT CHARACTERISTICS Offset Voltage ¹ | T _{MIN} to T _{MAX} | | 0.2 | 1.0 1.5 | | 0.05 | 0.25 0.5 | | 0.2 | 1.0 1.5 | mV mV |
| Hysteresis ² | T _{MIN} to T _{MAX} | 0.3 | 0.4 | 0.6 | 0.3 | 0.4 | 0.5 | 0.3 | 0.4 | 0.65 | mV |
| Bias Current | Either Input T _{MIN} to T _{MAX} | | 2.5 | 5 6.5 | | 1.8 | 3.5 4.5 | | 2.5 | 5 7 | μA μA |
| Offset Current | T _{MIN} to T _{MAX} | | 0.04 | 0.25 0.3 | | 0.02 | 0.15 0.2 | | 0.04 | 0.25 0.4 | μA μA |
| Power Supply Rejection Ratio DC | V _S ±20% T _{MIN} to T _{MAX} | 80 76 | 90 88 | | 88 85 | 100 93 | | 80 76 | 90 85 | | dB dB |
| Input Voltage Range Differential Voltage | V _S ≤ ±15 V | | | ±V _S | | | ±V _S | | | ±V _S | V |
| Common Mode | | -V _S | | +V _S -2 V | -V _S | | +V _S -2 V | -V _S | | +V _S -2 V | V |
| Common Mode Rejection Ratio | -10 V < V _{CM} < +10 V T _{MIN} to T _{MAX} | 80 76 | 95 90 | | 88 85 | 105 100 | | 80 76 | 95 88 | | dB dB |
| Input Impedance | | | 20 2 | | | 20 2 | | | 20 2 | | MΩ pF |
| LATCH CHARACTERISTICS Latch Hold Time, t _H | | | 25 | 35 | | 25 | 35 | | 25 | 35 | ns |
| Latch Setup Time, t _S | | | 5 | 10 | | 5 | 10 | | 5 | 10 | ns |
| LOW Input Level, V _{IL} | T _{MIN} to T _{MAX} | | | 0.8 | | | 0.8 | | | 0.8 | V |
| HIGH Input Level, V _{IH} | T _{MIN} to T _{MAX} | 1.6 | | | 1.6 | | | 1.6 | | | V |
| Latch Input Current | T _{MIN} to T _{MAX} | | 2.3 | 5 7 | | 2.3 | 3.5 5 | | 2.3 | 5 8 | μA μA |
| SUPPLY CHARACTERISTICS Diff Supply Voltage ³ | V _{LOGIC} = 5 V T _{MIN} to T _{MAX} | 4.5 | | 33 | 4.5 | | 33 | 4.7 | | 33 | V |
| Logic Supply | T _{MIN} to T _{MAX} | 4.0 | | 7 | 4.0 | | 7 | 4.2 | | 7 | V |
| Quiescent Current | | | | | | | | | | | |
| +V _S | +V _S = 15 V | | 8 | 10 | | 8 | 10 | | 8 | 10 | mA |
| -V _S | -V _S = -15 V | | 4 | 5 | | 4 | 5 | | 4 | 5 | mA |
| V _{LOGIC} | V _{LOGIC} = 5 V | | 2 | 3.3 | | 2 | 3.3 | | 2 | 3.3 | mA |
| Power Dissipation | | | | 242 | | | 242 | | | 242 | mW |
| TEMPERATURE RANGE Rated Performance | T _{MIN} to T _{MAX} | | 0 to 70/-40 | +85 | | 0 to 70/-40 | +85 | | -55 to +125 | | °C |

NOTES

¹Defined as the average of the input voltages at the low to high and high to low transition points. Refer to Figure 6.

²Defined as half the magnitude between the input voltages at the low to high and high to low transition points. Refer to Figure 6.

³+V_S must be no lower than (V_{LOGIC} - 0.5 V) in any supply operating conditions, except during power up.

All min and max specifications are guaranteed. Specifications shown in **boldface** are tested on all production units at final test.

Specifications subject to change without notice.

SINGLE SUPPLY (Operation @ 25°C and +V_S = V_{LOGIC} = 5 V, -V_S = 0 V unless otherwise noted.)¹

| Parameter | Conditions | AD790J/A | | | AD790K/B | | | AD790S | | | Unit | |
|--------------------------------------|--|--------------|-------------|----------------------|------------|-------------|----------------------|------------|-------------|----------------------|------------|---|
| | | Min | Typ | Max | Min | Typ | Max | Min | Typ | Max | | |
| RESPONSE CHARACTERISTIC | 100 mV Step | | | | | | | | | | | |
| Propagation Delay, t _{PD} | 5 mV Overdrive T _{MIN} to T _{MAX} | | 45 | 50 | | 45 | 50 | | 45 | 50 | ns | |
| | | | | 50/60 | | | 50/60 | | | 65 | ns | |
| OUTPUT CHARACTERISTICS | | | | | | | | | | | | |
| Output HIGH Voltage, V _{OH} | 1.6 mA Source | | | 4.65 | | | 4.65 | | | 4.65 | | |
| | 6.4 mA Source | 4.3 | | 4.45 | 4.3 | | 4.45 | 4.3 | | 4.45 | V | |
| | T _{MIN} to T _{MAX} | 4.3 | | | 4.3 | | | 4.3 | | | V | |
| Output LOW Voltage, V _{OL} | 1.6 mA Sink | | | 0.35 | | | 0.35 | | | 0.35 | V | |
| | 6.4 mA Sink | | | 0.44 | 0.5 | | 0.44 | 0.5 | | 0.44 | 0.5 | V |
| | T _{MIN} to T _{MAX} | | | | 0.5 | | | 0.5 | | 0.5 | V | |
| INPUT CHARACTERISTICS | | | | | | | | | | | | |
| Offset Voltage ² | | | 0.45 | 1.5 | | 0.35 | 0.6 | | 0.45 | 1.5 | mV | |
| | T _{MIN} to T _{MAX} | | | 2.0 | | | 0.85 | | | 2.0 | mV | |
| Hysteresis ³ | T _{MIN} to T _{MAX} | 0.3 | 0.5 | 0.75 | 0.3 | 0.5 | 0.65 | 0.3 | 0.7 | 1.0 | mV | |
| Bias Current | Either Input | | 2.7 | 5 | | 2.0 | 3.5 | | 2.7 | 5 | μA | |
| | T _{MIN} to T _{MAX} | | | 7 | | | 5 | | | 8 | μA | |
| Offset Current | | | 0.04 | 0.25 | | 0.02 | 0.15 | | 0.04 | 0.25 | μA | |
| | T _{MIN} to T _{MAX} | | | 0.3 | | | 0.2 | | | 0.4 | μA | |
| Power Supply Rejection Ratio DC | 4.5 V ≤ V _S ≤ 5.5 V | 80 | 90 | | 86 | 100 | | 80 | 90 | | dB | |
| | T _{MIN} to T _{MAX} | 76/76 | 88 | | 82 | 93 | | 76 | 85 | | dB | |
| Input Voltage Range | | | | ±V _S | | | ±V _S | | | ±V _S | V | |
| Differential Voltage | | | | +V _S -2 V | | | +V _S -2 V | | | +V _S -2 V | V | |
| Common Mode | | 0 | | | 0 | | | 0 | | | V | |
| Input Impedance | | | 20 2 | | | 20 2 | | | 20 2 | | MΩ pF | |
| LATCH CHARACTERISTICS | | | | | | | | | | | | |
| Latch Hold Time, t _H | | | 25 | 35 | | 25 | 35 | | 25 | 35 | ns | |
| Latch Setup Time, t _S | | | 5 | 10 | | 5 | 10 | | 5 | 10 | ns | |
| LOW Input Level, V _{IL} | T _{MIN} to T _{MAX} | | | 0.8 | | | 0.8 | | | 0.8 | V | |
| HIGH Input Level, V _{IH} | T _{MIN} to T _{MAX} | 1.6 | | | 1.6 | | | 1.6 | | | V | |
| Latch Input Current | T _{MIN} to T _{MAX} | | 2.3 | 5 | | 2.3 | 3.5 | | 2.3 | 5 | μA | |
| | | | | 7 | | | 5 | | | 8 | μA | |
| SUPPLY CHARACTERISTICS | | | | | | | | | | | | |
| Supply Voltage ⁴ | T _{MIN} to T _{MAX} | 4.5 | | 7 | 4.5 | | 7 | 4.7 | | 7 | V | |
| Quiescent Current | | | 10 | 12 | | 10 | 12 | | 10 | 12 | mA | |
| Power Dissipation | | | | 60 | | | 60 | | | 60 | mW | |
| TEMPERATURE RANGE | | | | | | | | | | | | |
| Rated Performance | T _{MIN} to T _{MAX} | | 0 to 70/-40 | to +85 | | 0 to 70/-40 | to +85 | | -55 to +125 | | °C | |

NOTES

¹Pin 1 tied to Pin 8, and Pin 4 tied to Pin 6.

²Defined as the average of the input voltages at the low to high and high to low transition points. Refer to Figure 6.

³Defined as half the magnitude between the input voltages at the low to high and high to low transition points. Refer to Figure 6.

⁴-V_S must not be connected above ground.

All min and max specifications are guaranteed. Specifications shown in **boldface** are tested on all production units at final test. Specifications subject to change without notice.

AD790

ABSOLUTE MAXIMUM RATINGS^{1, 2}

| | |
|---|-----------------|
| Supply Voltage | ±18 V |
| Internal Power Dissipation ² | 500 mW |
| Differential Input Voltage | ±16.5 V |
| Output Short-Circuit Duration | Indefinite |
| Storage Temperature Range | |
| (N, R) | -65°C to +125°C |
| (Q) | -65°C to +150°C |
| Lead Temperature Range (Soldering 60 sec) | 300°C |
| Logic Supply Voltage | 7 V |

NOTES

¹Stresses above those listed under "Absolute Maximum Ratings" may cause permanent damage to the device. This is a stress rating only and functional operation of the device at these or any other conditions above those indicated in the operational sections of this specification is not implied. Exposure to absolute maximum rating conditions for extended periods may affect device reliability.

²Thermal characteristics: plastic N-8 package: $\theta_{JA} = 90^\circ\text{C}/\text{watt}$; ceramic Q-8 package: $\theta_{JA} = 110^\circ\text{C}/\text{watt}$, $\theta_{JC} = 30^\circ\text{C}/\text{watt}$. SOIC (R-8) package: $\theta_{JA} = 160^\circ\text{C}/\text{watt}$; $\theta_{JC} = 42^\circ\text{C}/\text{watt}$.

ORDERING GUIDE

| Model | Temperature Range | Package Description | Package Option |
|---------------|-------------------|---------------------|----------------|
| AD790JN | 0°C to 70°C | Plastic DIP | N-8 |
| AD790JR | 0°C to 70°C | SOIC | SO-8 |
| AD790JR-REEL | 0°C to 70°C | Reel | |
| AD790JR-REEL7 | 0°C to 70°C | SOIC | R-8 |
| AD790KN* | 0°C to 70°C | Plastic DIP | N-8 |
| AD790AQ | -40°C to +85°C | Cer dip | Q-8 |
| AD790BQ* | -40°C to +85°C | Cer dip | Q-8 |
| AD790SQ | -55°C to +125°C | Cer dip | Q-8 |

*Not for new designs; obsolete April 2002.

For military processed devices, please refer to the standard Microcircuit Drawing (SMD) available at www.dscc.dla.mil/programs/milspec/default.asp

| SMD Part Number | ADI Equivalent |
|------------------|----------------|
| 5962-9150501MPA* | AD790 SQ/883 |

*Not for new designs; obsolete April 2002.

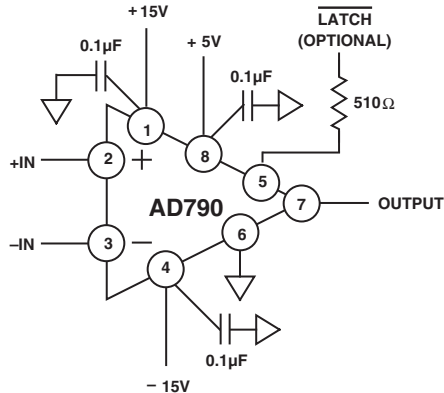

Figure 1. Basic Dual Supply Configuration (N, Q Package Pinout)

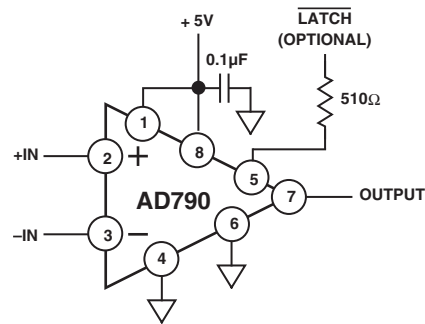
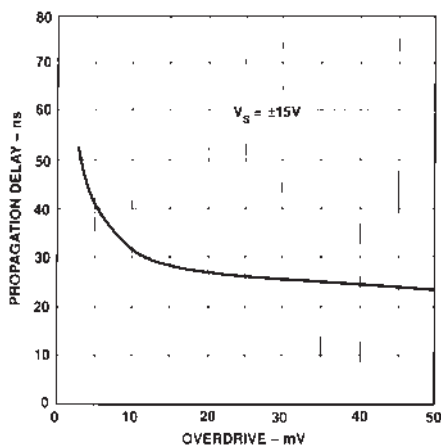

Figure 2. Basic Single Supply Configuration (N, Q Package Pinout)

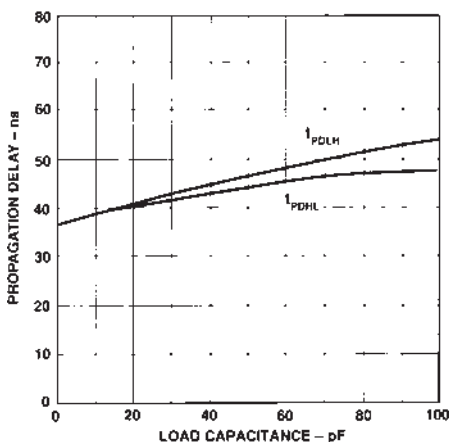

Figure 3. Response Time Test Circuit (N, Q Package Pinout)

Typical Performance Characteristics—AD790



TPC 1. Propagation Delay vs. Overdrive



TPC 2. Propagation Delay vs. Load Capacitance

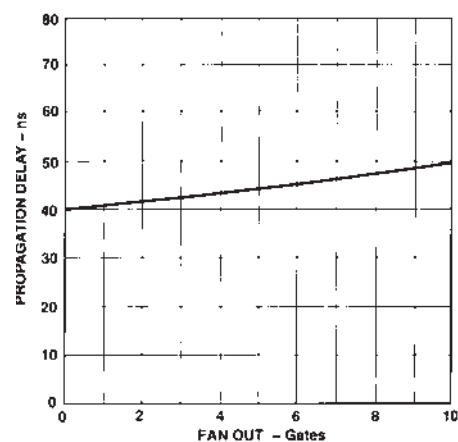

TPC 3. Propagation Delay vs. Fanout (LSTTL and CMOS)

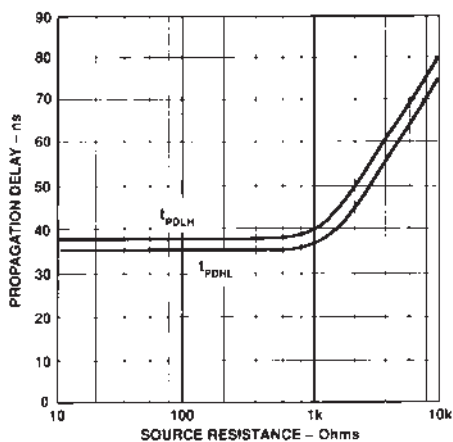

TPC 4. Propagation Delay vs. Source Resistance

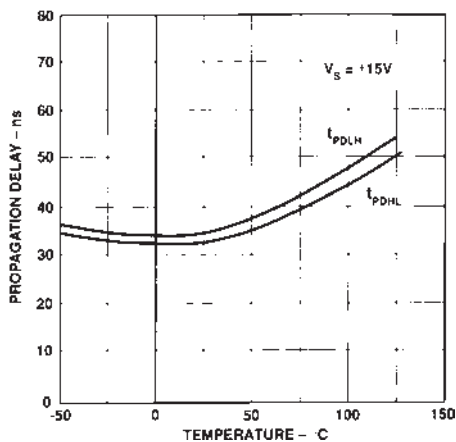

TPC 5. Propagation Delay vs. Temperature

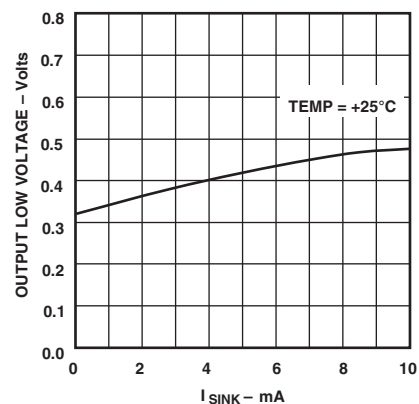

TPC 6. Output Low Voltage vs. Sink Current

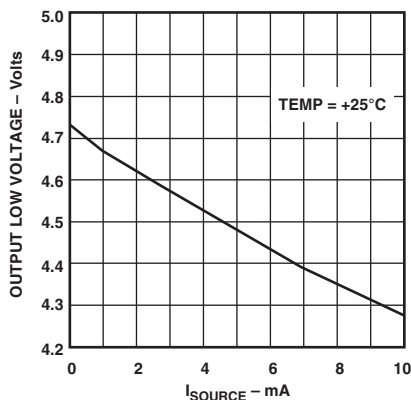

TPC 7. Output High Voltage vs. Source Current

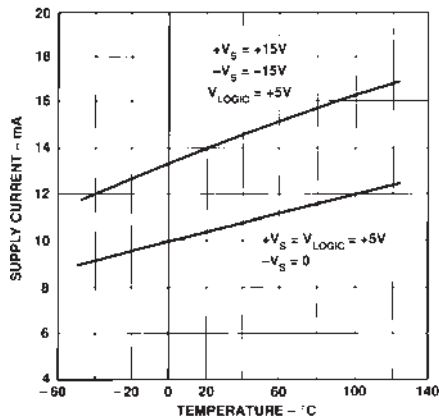

TPC 8. Total Supply Current vs. Temperature

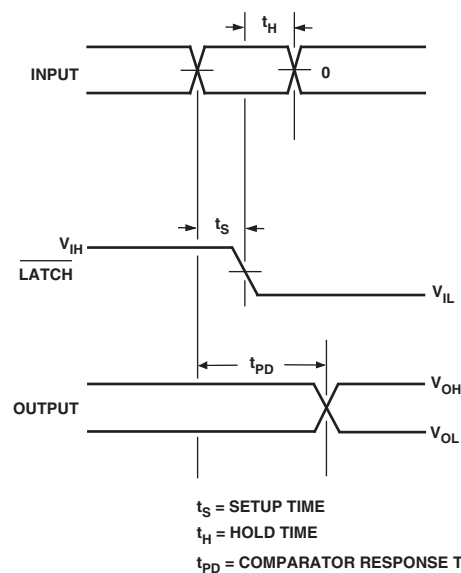

Figure 4. Latch Timing

AD790

CIRCUIT DESCRIPTION

The AD790 possesses the overall characteristics of a standard monolithic comparator: differential inputs, high gain and a logic output. However, its function is implemented with an architecture which offers several advantages over previous comparator designs. Specifically, the output stage alleviates some of the limitations of classic “TTL” comparators and provides a symmetric output. A simplified representation of the AD790 circuitry is shown in Figure 5.



Figure 5. AD790 Block Diagram

The output stage takes the amplified differential input signal and converts it to a single-ended logic output. The output swing is defined by the pull-up PNP and the pull-down NPN. These produce inherent rail-to-rail output levels, compatible with CMOS logic, as well as TTL, without the need for clamping to internal bias levels. Furthermore, the pull-up and pull-down levels are symmetric about the center of the supply range and are referenced off the V_{LOGIC} supply and ground. The output stage has nearly symmetric dynamic drive capability, yielding equal rise and fall times into subsequent logic gates.

Unlike classic TTL or CMOS output stages, the AD790 circuit does not exhibit large current spikes due to unwanted current flow between the output transistors. The AD790 output stage has a controlled switching scheme in which amplifiers A1 and A2 drive the output transistors in a manner designed to reduce the current flow between Q1 and Q2. This also helps minimize the disturbances feeding back to the input which can cause troublesome oscillations.

The output high and low levels are well controlled values defined by V_{LOGIC} (5 V), ground and the transistor equivalent Schottky clamps and are compatible with TTL and CMOS logic requirements. The fanout of the output stage is shown in TPC 3 for standard LSTTL or HCMOS gates. Output drive behavior vs. capacitive load is shown in TPC 2.

HYSTERESIS

The AD790 uses internal feedback to develop hysteresis about the input reference voltage. Figure 6 shows how the input offset voltage and hysteresis terms are defined. Input offset voltage (V_{OS}) is the difference between the center of the hysteresis range and the ground level. This can be either positive or negative. The hysteresis voltage (V_{H}) is one-half the width of the

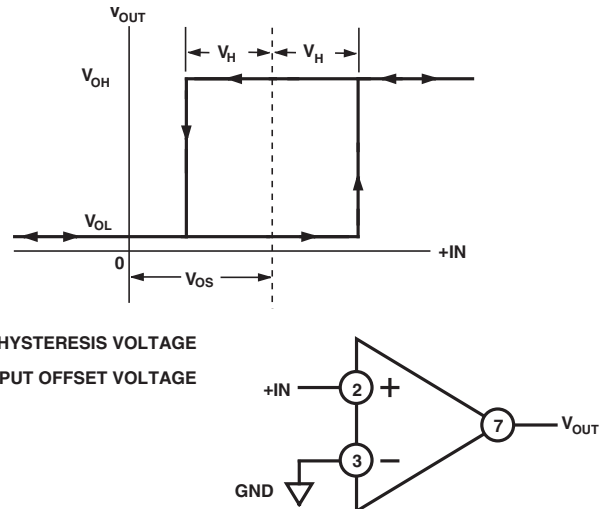

V_{H} = HYSTERESIS VOLTAGE
 V_{OS} = INPUT OFFSET VOLTAGE

Figure 6. Hysteresis Definitions (N, Q Package Pinout)

hysteresis range. This built-in hysteresis allows the AD790 to avoid oscillation when an input signal slowly crosses the ground level.

SUPPLY VOLTAGE CONNECTIONS

The AD790 may be operated from either single or dual supply voltages. Internally, the V_{LOGIC} circuitry and the analog front-end of the AD790 are connected to separate supply pins. If dual supplies are used, any combination of voltages in which $+V_{\text{S}} \geq V_{\text{LOGIC}} - 0.5 \text{ V}$ and $-V_{\text{S}} \leq 0$ may be chosen. For single supply operation (i.e., $+V_{\text{S}} = V_{\text{LOGIC}}$), the supply voltage can be operated between 4.5 V and 7 V. Figure 7 shows some other examples of typical supply connections possible with the AD790.

BYPASSING AND GROUNDING

Although the AD790 is designed to be stable and free from oscillations, it is important to properly bypass and ground the power supplies. Ceramic 0.1 μF capacitors are recommended and should be connected directly at the AD790’s supply pins. These capacitors provide transient currents to the device during comparator switching. The AD790 has three supply voltage pins, $+V_{\text{S}}$, $-V_{\text{S}}$ and V_{LOGIC} . It is important to have a common ground lead on the board for the supply grounds and the GND pin of the AD790 to provide the proper return path for the supply current.

LATCH OPERATION

The AD790 has a latch function for retaining input information at the output. The comparator decision is “latched” and the output state is held when Pin 5 is brought low. As long as Pin 5 is kept low, the output remains in the high or low state, and does not respond to changing inputs. Proper capture of the input signal requires that the timing relationships shown in Figure 4 are followed. Pin 5 should be driven with CMOS or TTL logic levels.

The output of the AD790 will respond to the input when Pin 5 is at a high logic level. When not in use, Pin 5 should be connected to the positive logic supply. When using dual supplies, it is recommended that a 510 Ω resistor be placed in series with Pin 5 and the driving logic gate to limit input currents during powerup.



Figure 7. Typical Power Supply Connections (N, Q Package Pinout)

Window Comparator for Overvoltage Detection

The wide differential input range of the AD790 makes it suitable for monitoring large amplitude signals. The simple overvoltage detection circuit shown in Figure 8 illustrates direct connection of the input signal to the high impedance inputs of the comparator without the need for special clamp diodes to limit the differential input voltage across the inputs.



Figure 8. Overvoltage Detector (N, Q Package Pinout)

Single Supply Ground Referred Overload Detector

The AD790 is useful as an overload detector for sensitive loads that must be powered from a single supply. A simple ground referred overload detector is shown in Figure 9. The comparator senses a voltage across a PC board trace and compares that to a reference (trip) voltage established by the comparator's minus supply current through a 2.7 Ω resistor. This sets up a 10 mV reference level that is compared to the sense voltage.

The minus supply current is proportional to absolute temperature and compensates for the change in the sense resistance with temperature. The width and length of the PC board trace determine the resistance of the trace and consequently the trip current level.

$$I_{LIMIT} = 10 \text{ mV}/R_{SENSE}$$

$$R_{SENSE} = \rho (\text{trace length}/\text{trace width})$$

ρ = resistance of a unit square of trace

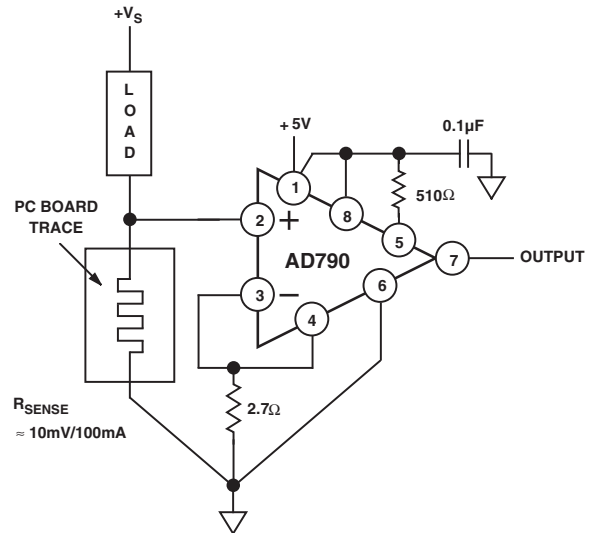

Figure 9. Ground Referred Overload Detector Circuit (N, Q Package Pinout)

Precision Full-Wave Rectifier

The high speed and precision of the AD790 make it suitable for use in the wide dynamic range full-wave rectifier shown in Figure 10. This circuit is capable of rectifying low level signals as small as a few mV or as high as 10 V. Input resolution, propagation delay and op amp settling will ultimately limit the maximum input frequency for a given accuracy level. Total comparator plus switch delay is approximately 100 ns, which limits the maximum input frequency to 1 MHz for clean rectification.

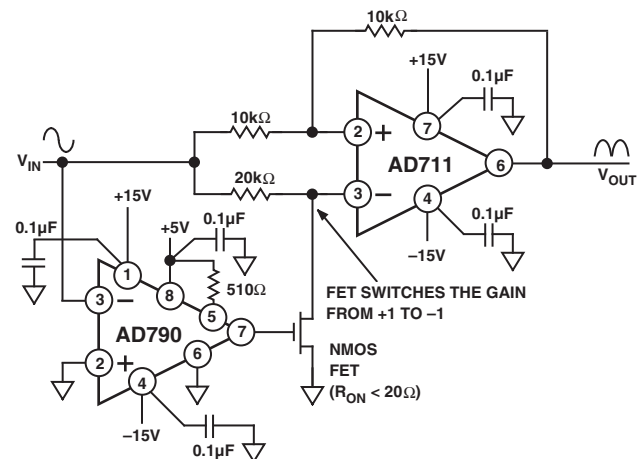

Figure 10. Precision Full-Wave Rectifier (N, Q Package Pinout)

AD790



*A RESISTOR UP TO 10kΩ MAYBE USED TO REDUCE THE SOURCE AND SINK CURRENT OF THE DRIVER. HOWEVER, THIS WILL SLIGHTLY LOWER THE MAXIMUM USABLE CLOCK RATE.

Figure 11. A Bipolar to CMOS TTL Line Receiver (N, Q Package Pinout)

Bipolar to CMOS/TTL

It is sometimes desirable to translate a bipolar signal (e.g., ± 5 V) coming from a communications cable or another section of the system to CMOS/TTL logic levels; such an application is referred to as a line receiver. Previously, the interface to the bipolar signal required either a dual (\pm) power supply or a reference voltage level about which the line receiver would switch. The AD790 may be used in a simple circuit to provide a unique capability: the ability to receive a bipolar signal while powered from a single 5 V supply. Other comparators cannot perform this task. Figure 11 shows a 1 k Ω resistor in series with the input signal which is then clamped by a Schottky diode, holding the input of the comparator at 0.4 V below ground. Although the comparator is specified for a common mode range down to $-V_S$, (in this case ground) it is permissible to bring one of the inputs a few hundred mV below ground. The comparator switches around this level and produces a CMOS/TTL compatible swing. The circuit will operate to switching frequencies of 20 MHz.

OUTLINE DIMENSIONS

Dimensions shown in inches and (mm).

8-Pin Plastic Mini-DIP (N-8) Package



8-Pin Cerdip (Q-8) Package



SOIC (R-8) Package

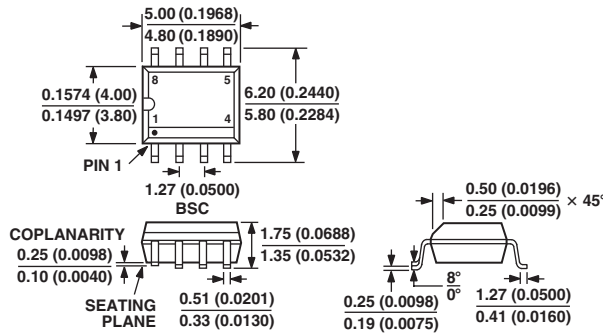

CONTROLLING DIMENSIONS ARE IN MILLIMETERS; INCH DIMENSIONS (IN PARENTHESES) ARE ROUNDED-OFF MILLIMETER EQUIVALENTS FOR REFERENCE ONLY AND ARE NOT APPROPRIATE FOR USE IN DESIGN

COMPLIANT TO JEDEC STANDARDS MS-012 AA

AD790

Revision History

| Location | Page |
|--|-------------|
| Data Sheet changed from REV. C to REV. D. | |
| Edits to SOIC (R-8) Package | 9 |
| 03/02—Data Sheet changed from REV. B to REV. C. | |
| Edits to FEATURES | 1 |
| Edits to PRODUCT DESCRIPTION | 1 |
| Deleted METALIZATION PHOTOGRAPH | 4 |
| Edits to ORDERING GUIDE | 4 |



Стандарт Электрон Связь

Мы молодая и активно развивающаяся компания в области поставок электронных компонентов. Мы поставляем электронные компоненты отечественного и импортного производства напрямую от производителей и с крупнейших складов мира.

Благодаря сотрудничеству с мировыми поставщиками мы осуществляем комплексные и плановые поставки широчайшего спектра электронных компонентов.

Собственная эффективная логистика и склад в обеспечивает надежную поставку продукции в точно указанные сроки по всей России.

Мы осуществляем техническую поддержку нашим клиентам и предпродажную проверку качества продукции. На все поставляемые продукты мы предоставляем гарантию .

Осуществляем поставки продукции под контролем ВП МО РФ на предприятия военно-промышленного комплекса России , а также работаем в рамках 275 ФЗ с открытием отдельных счетов в уполномоченном банке. Система менеджмента качества компании соответствует требованиям ГОСТ ISO 9001.

Минимальные сроки поставки, гибкие цены, неограниченный ассортимент и индивидуальный подход к клиентам являются основой для выстраивания долгосрочного и эффективного сотрудничества с предприятиями радиоэлектронной промышленности, предприятиями ВПК и научно-исследовательскими институтами России.

С нами вы становитесь еще успешнее!

Наши контакты:

Телефон: +7 812 627 14 35

Электронная почта: sales@st-electron.ru

Адрес: 198099, Санкт-Петербург,
Промышленная ул, дом № 19, литера Н,
помещение 100-Н Офис 331