

# ISL28006 Evaluation Board User's Guide

## Introduction

The ISL28006 evaluation board is a design platform containing all the circuitry needed to characterize critical performance parameters of the ISL28006 in either a high side or low-side current sense application. The ISL28006 is available in fixed 100V/V, 50V/V, 20V/V and adjustable gains.

## Reference Documents

- ISL28006 Data Sheet, [FN6548](#)

## Evaluation Board Schematic

The ISL2800XEVAL1Z evaluation board is configured with either the ISL28006-100, ISL28006-50, ISL28006-20 or the ISL28006-ADJ device (adjustable gain via external resistors R<sub>11</sub> and R<sub>14</sub>). Note: When using the adjustable part, V-REF (J<sub>1</sub>) needs to be grounded. J<sub>13</sub> is provided to enable accurate voltage measurements across the sense resistor R<sub>3</sub>.

Figure 1 shows the basic application circuit and optional protection components for the fixed gain parts. Figure 2 shows the basic application circuit and optional protection components for the adjustable gain part. Figure 3 shows the complete schematic for the ISL2800XEVAL1Z evaluation board.

Components shown in red in both Figures 1 and 2 are optional transient protection and not required for clean environments. Note: The evaluation board comes equipped with the transient protection devices.

## Optional Transient Protection

For applications where the load and the power source are permanently connected, transient protection is not required and only an external current sense resistor (R<sub>3</sub>) is needed.

For applications where fast transients can generate voltage spikes that can overdrive the amplifier input and drive the output of the amplifier into the rails, a long overload recovery time will result. Common mode capacitors C<sub>7</sub>, C<sub>9</sub> and differential capacitor C<sub>8</sub> are used to filter the common mode and differential voltage spikes.

For switching applications or where fast transients are caused by hot plugging the source or load, external protection components may be needed. The external

current limiting resistor (R<sub>6</sub>) in Figure 1 will limit the peak current through the internal ESD diodes to <20mA. This condition can occur in applications that experience high levels of in-rush current causing high peak voltages that can damage the internal ESD diodes of the ISL28006. If the current limiting resistor is required, it needs to be placed on the RS- input (R<sub>6</sub>). Placing it on the RS+ input side (R<sub>7</sub>) will result in a much larger error voltage due to the ISL28006 taking its supply current from the sense current in high-side applications.

For example:

Current limiting resistor R<sub>6</sub> with a value of 100Ω will provide protection for a 2V transient with the maximum of 20mA flowing through the input while adding only an additional 13μV (worst case over-temperature) of V<sub>OS</sub> as shown in Equation 1. Note: Worst case over-temperature input bias current on the RS- input is 130nA.

$$R_6 \times I_{RS-} = 100\Omega \times 130\text{nA} = 13\mu\text{V} \quad (\text{EQ. 1})$$

Current limiting resistor R<sub>7</sub> with value of 100Ω will provide the same transient protection, but with an error voltage of 800μV. Note: Worst case over-temperature input bias current on the RS+ input is 8μA as shown in Equation 2.

$$R_7 \times I_{RS+} = 100\Omega \times 8\mu\text{A} = 800\mu\text{V} \quad (\text{EQ. 2})$$

R<sub>7</sub> is a carry-over from our characterization board and was used to measure input bias current. The evaluation board is populated with a zero ohm resistor for R<sub>7</sub>.

## Power Supplies

External power connections are made through the VS+ and Ground connections on the evaluation board. Capacitors C<sub>2</sub> and C<sub>4</sub> perform two duties, de-coupling the supplies and filtering of the power supply noise with R<sub>15</sub>. Anti-reverse diodes D<sub>1</sub> and D<sub>3</sub> protect the circuit in the case of accidental polarity reversal of the supply. Resistor R<sub>12</sub> is used to connect ground to the fixed gain parts.

## ISL2800XEVAL1Z and BOM

Figure 4 shows the top view of the ISL2800XEVAL1Z evaluation board. The evaluation board Bill of Materials is given in Table 2.

# Application Note 1532

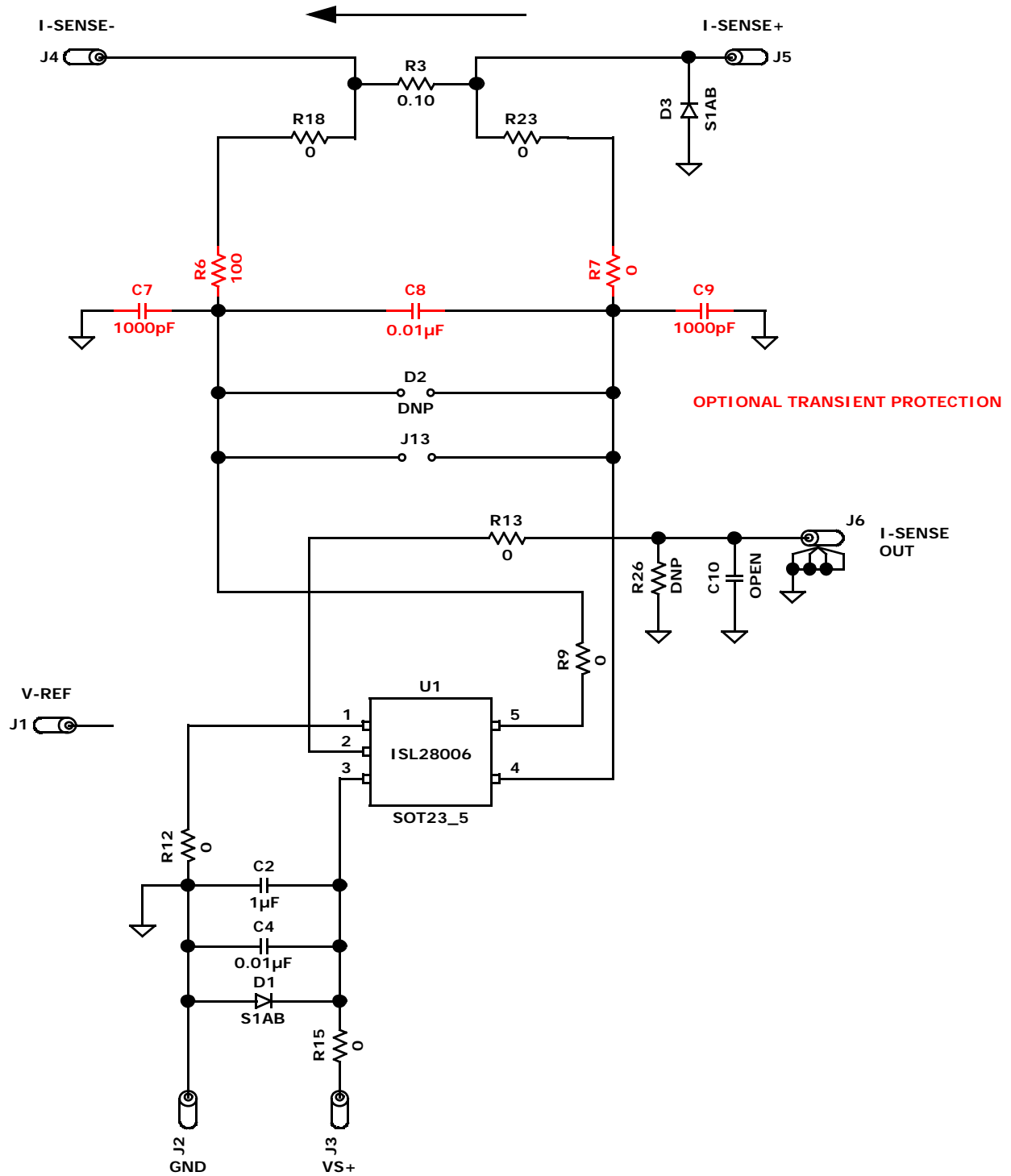

FIGURE 1. SIMPLIFIED ISL2800XEVAL1Z SCHEMATIC DIAGRAM FOR FIXED GAIN PARTS

# Application Note 1532

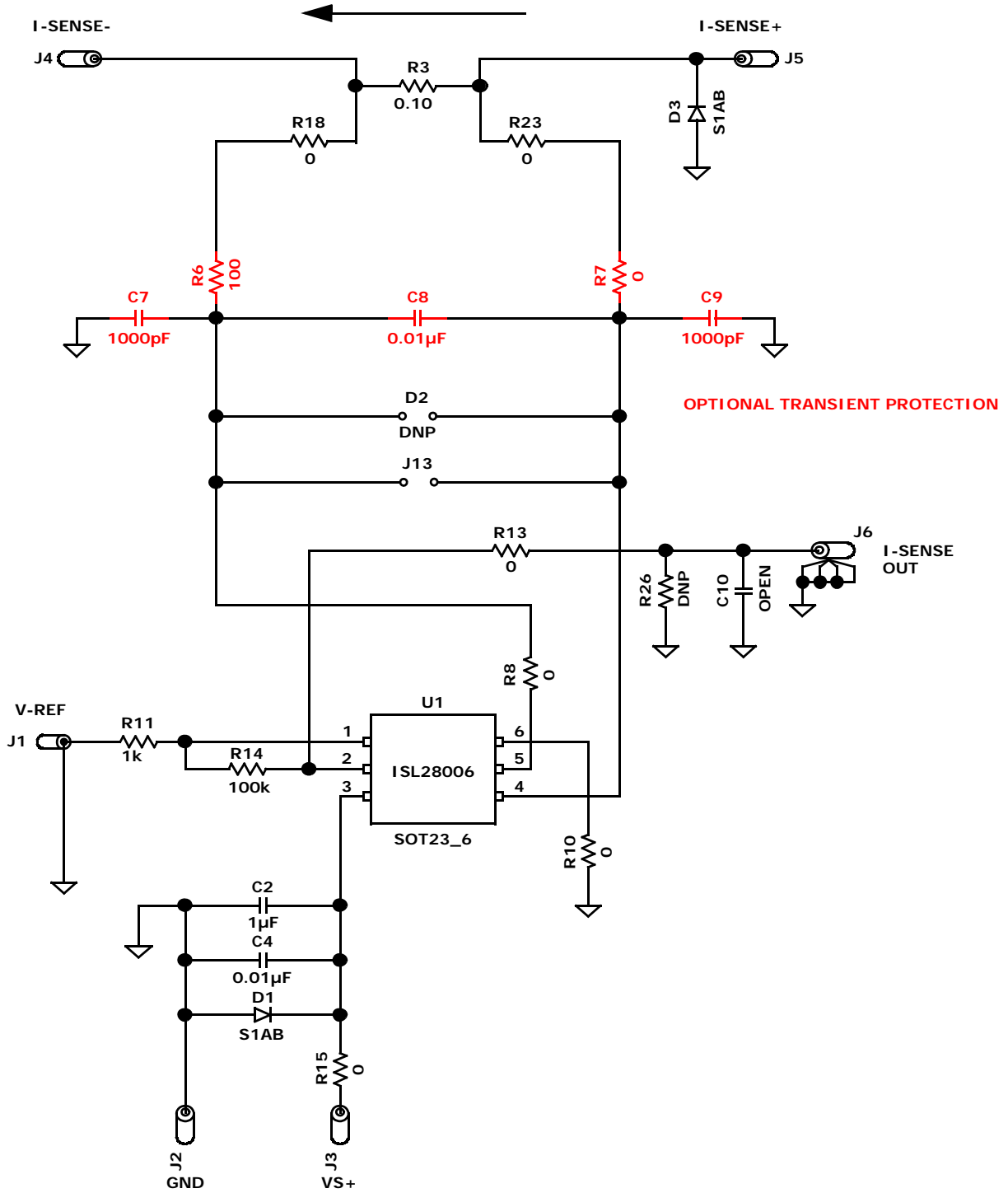

FIGURE 2. SIMPLIFIED ISL2800XEVAL1Z SCHEMATIC DIAGRAM FOR ADJUSTABLE GAIN PARTS

# Application Note 1532

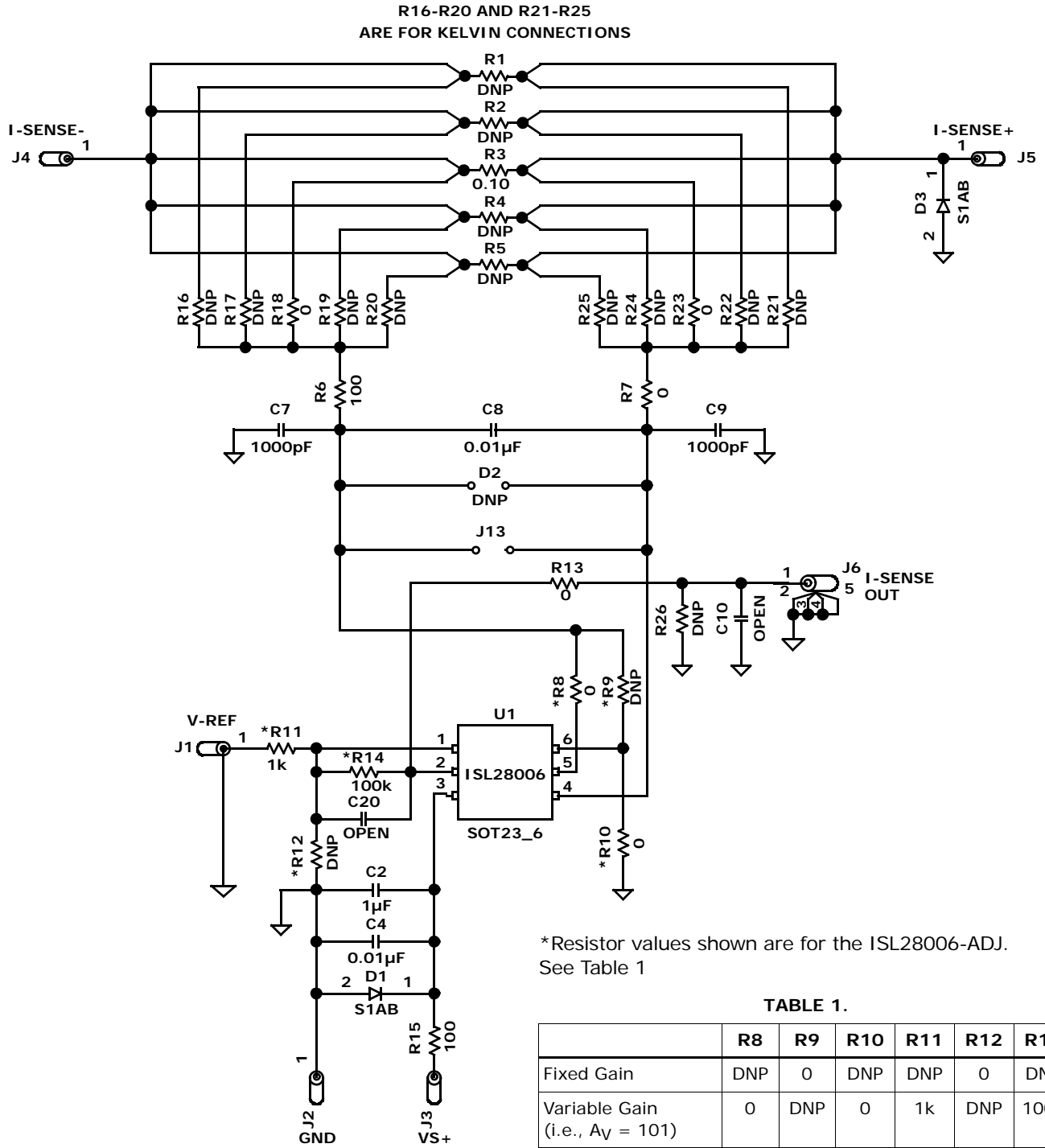

FIGURE 3. ISL2800XEVAL1Z SCHEMATIC DIAGRAM

# Application Note 1532

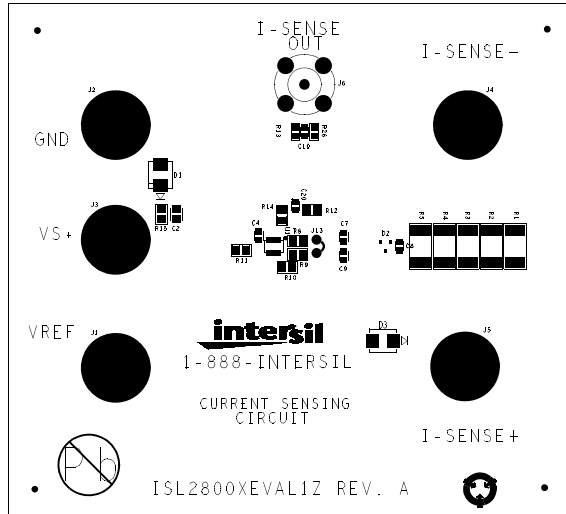

FIGURE 4. ISL2800XEVAL1Z TOP VIEW

TABLE 2. ISL2800XEVAL1Z COMPONENTS PARTS LIST

DEVICE #	DESCRIPTION	COMMENTS
C2	CAP, SMD, 0805, 1 $\mu$ F, 50V, 20%, X7R, ROHS	Power Supply Decoupling and Input Filter
C4, C8	CAP, SMD, 0603, 0.01 $\mu$ F, 50V, 10%, X7R, ROHS	Power Supply Decoupling/Input Filter and Differential Current Sense Filter
C7, C9	CAP, SMD, 0603, 1000pF, 50V, 10%, X7R, ROHS	Common Mode Current Sense Filter
C10, C20	CAP, SMD, 0603, DNP-Place Holder, ROHS	User Selectable Capacitors - Not Populated
D1, D3	Diode-Rectifier, SMD, S1AB, 50V, ROHS	Reverse Power Protection
U1 (ISL28006-100EVAL1Z)	ISL28006FH100Z-T7, SOT-23, ROHS	
U1 (ISL28006-50EVAL1Z)	ISL28006FH50Z-T7, SOT-23, ROHS	
U1 (ISL28006-20EVAL1Z)	ISL28006FH20Z-T7, SOT-23, ROHS	
U1 (ISL28006-ADJEVAL1Z)	ISL28006FHADJZ-T7-T7, SOT-23, ROHS	
R16, R17, R19, R20, R21, R22, R24, R25	Resistor, SMD, 0603, MF, DNP-Place Holder	User Selectable Kelvin Connection - Not Populated
R26	Resistor, SMD, 0603, MF, DNP-Place Holder	User Selectable Output Load Resistor - Not Populated
R3	Resistor, SMD, 2512, 0.1 $\Omega$ , 1W, 1%, TF, ROHS	SENSE resistor
R1, R2, R4, R5	Resistor, SMD, 2512, DNP-Place Holder	User Selectable SENSE Resistors - Not Populated
R6, R7, R13, R18, R23	Resistor, SMD, 0603, 0 $\Omega$ , 1/10W, TF, ROHS	Zero Ohm User Selectable Resistors
R15	Resistor, SMD, 0603, 100 $\Omega$ , 1/10W, TF, ROHS	Current Limiting Resistors
R11	Resistor, SMD, 0603, 1k $\Omega$ , 1/10W, 1%, TF, ROHS (Variable Gain) RES, SMD, 0603, DNP-Place Holder (Fixed Gain)	Gain and Other User Selectable Resistors
R14	Resistor, SMD, 0603, 100k $\Omega$ , 1/10W, 1%, TF, ROHS (Variable Gain) RES, SMD, 0603, DNP-Place Holder (Fixed Gain)	Gain and Other User Selectable Resistors
R8, R10	Resistor, SMD, 0603, 0 $\Omega$ , 1/10W, 1%, TF, ROHS (Variable Gain) Resistor, SMD, 0603, DNP-Place Holder (Fixed Gain)	Gain and Other User Selectable Resistors
R9, R12	Resistor, SMD, 0603, DNP-Place Holder (Variable Gain) Resistor, SMD, 0603, 0 $\Omega$ , 1/10W, 1%, TF, ROHS (Fixed Gain)	Gain and Other User Selectable Resistors

Intersil Corporation reserves the right to make changes in circuit design, software and/or specifications at any time without notice. Accordingly, the reader is cautioned to verify that the Application Note or Technical Brief is current before proceeding.

For information regarding Intersil Corporation and its products, see [www.intersil.com](http://www.intersil.com)



## Стандарт Электрон Связь

Мы молодая и активно развивающаяся компания в области поставок электронных компонентов. Мы поставляем электронные компоненты отечественного и импортного производства напрямую от производителей и с крупнейших складов мира.

Благодаря сотрудничеству с мировыми поставщиками мы осуществляем комплексные и плановые поставки широчайшего спектра электронных компонентов.

Собственная эффективная логистика и склад в обеспечивает надежную поставку продукции в точно указанные сроки по всей России.

Мы осуществляем техническую поддержку нашим клиентам и предпродажную проверку качества продукции. На все поставляемые продукты мы предоставляем гарантию .

Осуществляем поставки продукции под контролем ВП МО РФ на предприятия военно-промышленного комплекса России , а также работаем в рамках 275 ФЗ с открытием отдельных счетов в уполномоченном банке. Система менеджмента качества компании соответствует требованиям ГОСТ ISO 9001.

Минимальные сроки поставки, гибкие цены, неограниченный ассортимент и индивидуальный подход к клиентам являются основой для выстраивания долгосрочного и эффективного сотрудничества с предприятиями радиоэлектронной промышленности, предприятиями ВПК и научно-исследовательскими институтами России.

С нами вы становитесь еще успешнее!

### Наши контакты:

**Телефон:** +7 812 627 14 35

**Электронная почта:** [sales@st-electron.ru](mailto:sales@st-electron.ru)

**Адрес:** 198099, Санкт-Петербург,  
Промышленная ул, дом № 19, литера Н,  
помещение 100-Н Офис 331