

Applications

- Distribution Amplifiers
- Multi Dwelling Units
- Drop Amplifiers
- Single Ended Gain Block

Product Features

- 75 Ohm, 50-1000 MHz Bandwidth
- pHEMT Device Technology
- On-Chip Active Bias and Negative Feedback
- Low Noise: < 2.6 dB to 1000 MHz
- Low Distortion: CSO -72, CTB -88 dBc (at Pout = +26 dBmV/ch, 80 ch flat loading)
- 16.1 dB Typical Gain
- +39 dBm Typical OIP3
- +22 dBm Typical P1dB
- 2.3 dB Typical NF and < 2.6 dB up to 1000 MHz
- Unconditionally Stable
- Low Power Consumption: +5.0 V, 130 mA
- SOT-89 package

General Description

The TAT7461 is a 75 Ohm RF Amplifier designed for CATV applications to 1000 MHz. The balance of low noise and distortion provides an outstanding solution for drop and distribution amplifiers.

The TAT7461 is fabricated using 6-inch GaAs pHEMT technology to optimize performance and cost. On-chip negative feedback provides excellent gain and return loss stability. The TAT7461 also uses an on-chip active bias for consistent bias current and repeatable performance. Simple external tuning allows the TAT7461 to achieve excellent return loss.



SOT-89 Package

Functional Block Diagram

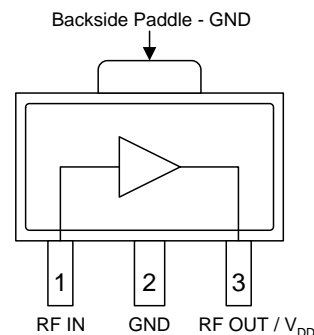

Top View

Pin Configuration

Pin No.	Label
1	RF IN
2	GND
3	RF OUT / V _{DD}
Backside Paddle	GND

Ordering Information

Part No.	Description
TAT7461	75 Ω pHEMT Amplifier
TAT7461-EVB	50-1000 MHz Evaluation Board
Standard T/R size = 1000 pieces on a 7" reel	

Absolute Maximum Ratings

Parameter	Rating
Operating Temperature	-65 to 85 °C
RF Input Power, CW, 75 Ω, T=25°C	+27 dBm
Supply Voltage (V _{DD})	+10.0 V

Operation of this device outside the parameter ranges given above may cause permanent damage.

Recommended Operating Conditions

Parameter	Min	Typ	Max	Units
V _{DD}		+6.0		V
I _{DD}	100	130	150	mA
T _{CASE}	-40		+85	°C
T _j for >10 ⁶ hours MTTF			+150	°C

Electrical performance is measured under conditions noted in the electrical specifications table. Specifications are not guaranteed over all recommended operating conditions.

Electrical Specifications

Test conditions unless otherwise noted: V_{DD} = +6 V, Temp = +25 °C.

Parameter	Conditions	Min	Typ	Max	Units
Operational Frequency Range		50		1000	MHz
Gain			16.1		dB
Gain Flatness			±0.3		dB
Noise Figure			2.3		dB
Input Return Loss			23		dB
Output Return Loss			23		dB
CSO	+26 dBmV/ch at output, 80 ch. flat		-72		dBc
CTB	+26 dBmV/ch at output, 80 ch. flat		-88		dBc
Output IP2	P _{out} = +5 dBm/tone, Δf = 1 MHz		+61		dBm
Output IP3	P _{out} = +5 dBm/tone, Δf = 1 MHz		+39		dBm
Supply Current		100	130	150	mA
Thermal Resistance, θ _{jc}	Module (junction to case)		42		°C/W

Device Characterization Data

Test conditions unless otherwise stated: $V_{DD} = +6V$, $I_{DD} = 130\text{ mA}$ (typ.) Temp = $+25^{\circ}C$.

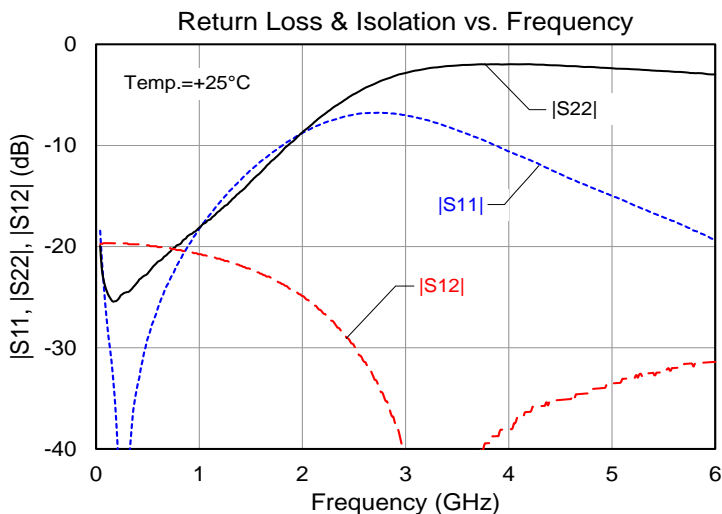
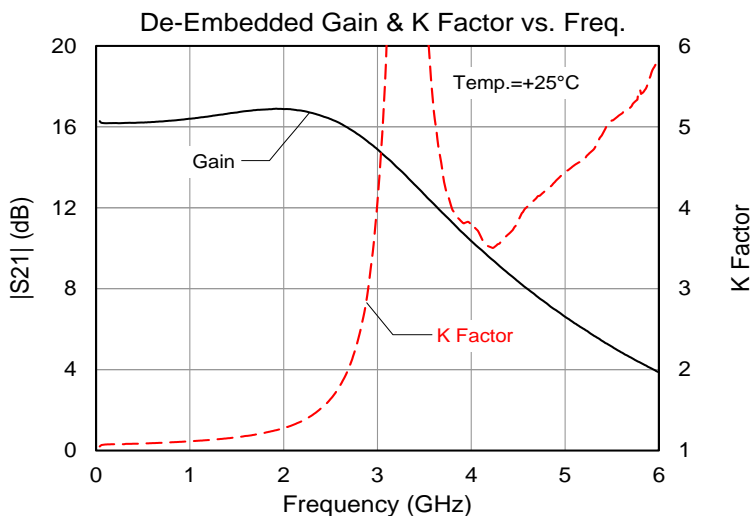
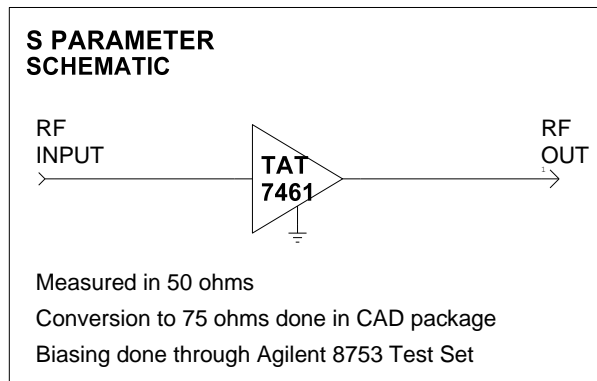

Application Schematic – TAT7461-EVB

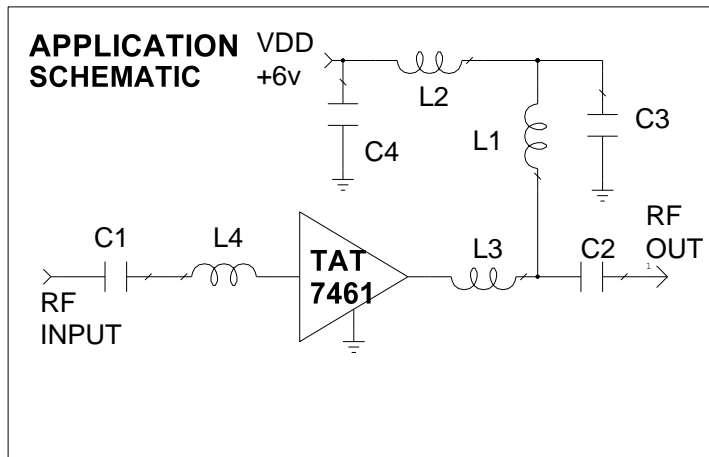

Bill of Material – TAT7461-EVB

Ref. Des.	Value	Description	Manuf.	Part Number
U1	n/a	75 Ω High Linearity pHEMT Amplifier	TriQuint	TAT7461
L1, L2	880 nH	Chip Coil, Vertical Wire Wound Ferrite, 1206, 30%	Murata1	LQH31HNR88K
L3	5.1 nH	Ceramic Chip Ind., Wire-wound, 0402, 5 %	Coilcraft	0402CS-5N1XJLW
L4	2.7 nH	Ceramic Chip Ind., Wire-wound, 0402, 5 %	Coilcraft	0402CS-2N7XJLW
C1	1000 pF	Ceramic Chip Cap., 0402, 50 V, 10 %, X7R	AVX1	04025C102KAT2A
C2	120 pF	Ceramic Chip Cap., 0402, 50 V, 5 %, NPO	AVX1	04025A121JAT2A
C3, C4	0.01 uF	Ceramic Chip Cap., 0402, 16 V, 10 %, X7R	AVX1	0402YC103KAT
J1, J2		75 Ω F connector	Lighthouse	FSF55MGT-P-10A ⁽¹⁾

Notes:

1. Or equivalent

Evaluation Board PCB Information

TriQuint PCB 50-0109 Material and Stack-up

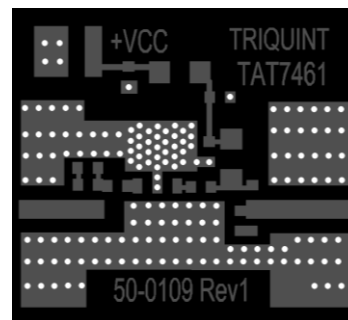
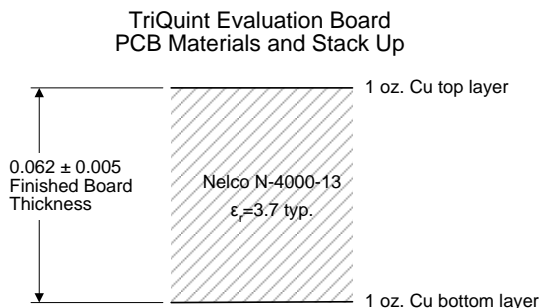

Performance Plots – TAT7461-EVB

Test conditions unless otherwise stated: $V_{DD} = +6V$, $I_{DD} = 130\text{ mA}$ (typ.)

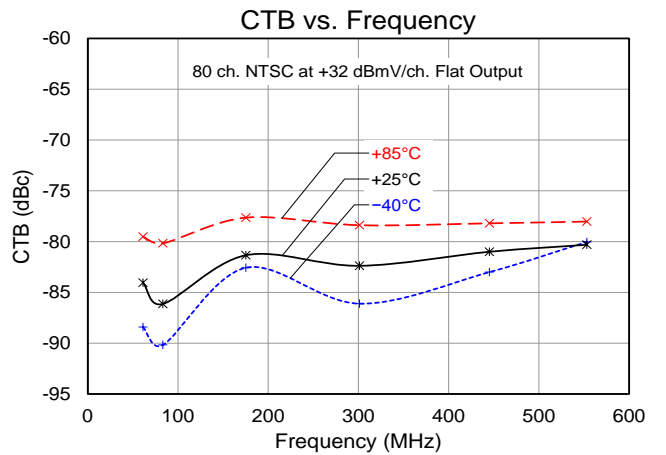
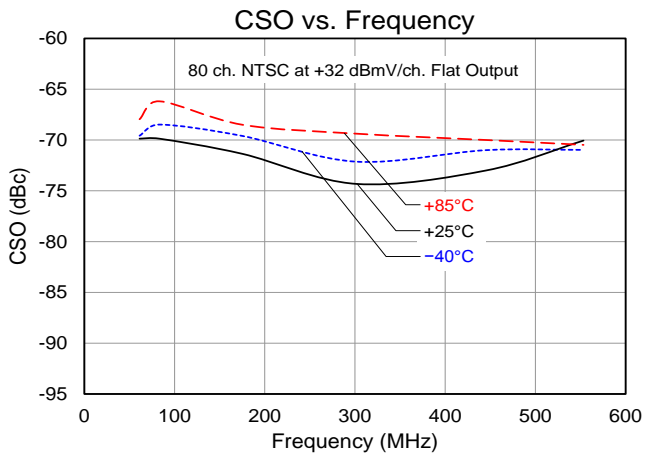
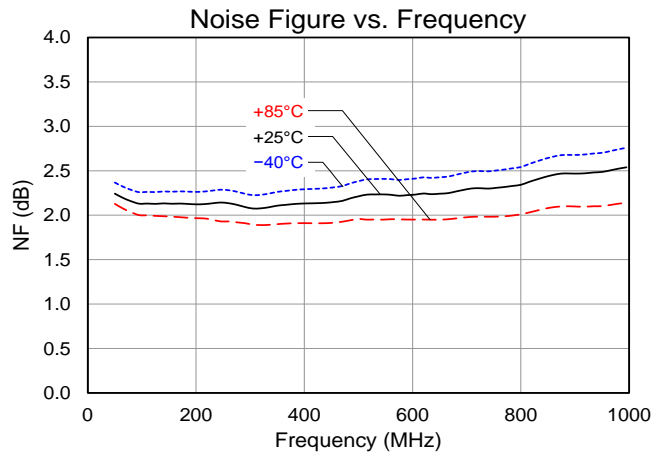
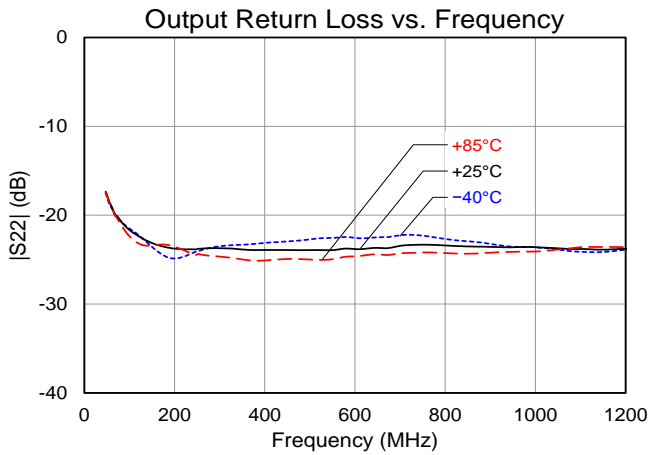
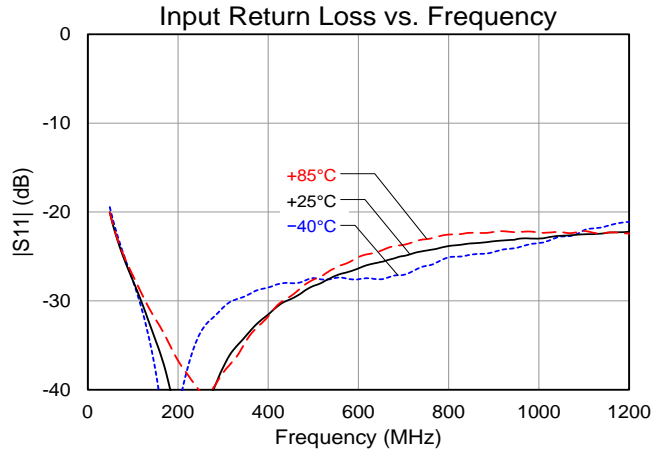
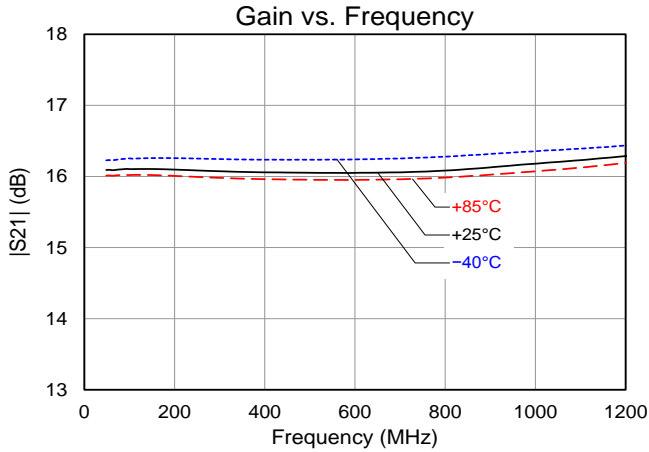

Package Marking and Dimensions

Marking: Part number – TAT7461
 Lot code –XXXXYYWW

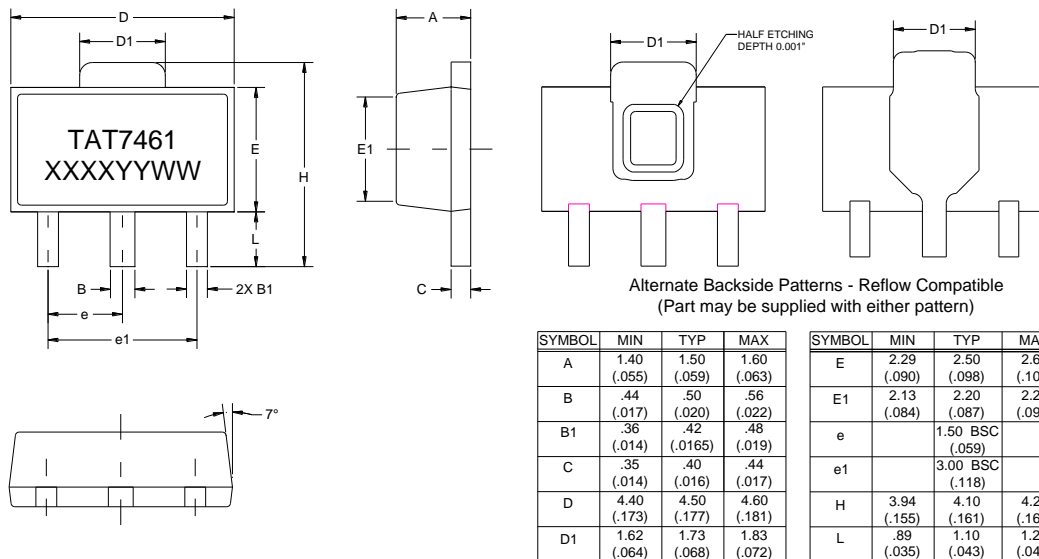

Notes:
 1. All dimensions are in millimeters. Angles are in degrees.

PCB Mounting Pattern

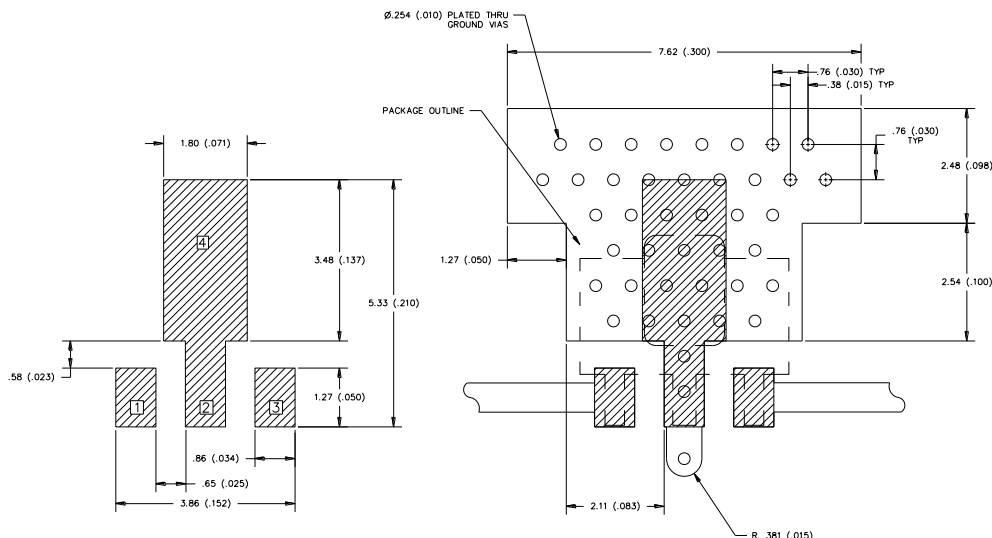

Notes:

1. All dimensions are in millimeters. Angles are in degrees.
2. Use 1 oz. copper minimum for top and bottom layer metal.
3. Vias are required under the backside paddle of this device for proper RF/DC grounding and thermal dissipation.
4. We recommend a 0.35mm (#80/.0135") diameter bit for drilling via holes and a final plated thru diameter of 0.25 mm (0.10").
5. Ensure good package backside paddle solder attach for reliable operation and best electrical performance.

Product Compliance Information

ESD Sensitivity Ratings



Caution! ESD-Sensitive Device

ESD Rating: Class 1A
Value: ≥ 250 V to < 500 V
Test: Human Body Model (HBM)
Standard: ESDA/JEDEC Standard JS-001-2012

ESD Rating: Class C3
Value: Passes ≥ 1000 V
Test: Charged Device Model (CDM)
Standard: JEDEC Standard JESD22-C101F

MSL Rating

MSL Rating: Level 3
Test: 260°C convection reflow
Standard: JEDEC Standard IPC/JEDEC J-STD-020

Solderability

Compatible with both lead-free (260°C maximum reflow temperature) and tin/lead (245°C maximum reflow temperature) soldering processes.

Contact plating: NiPdAu

RoHS Compliance

This part is compliant with EU 2002/95/EC RoHS directive (Restrictions on the Use of Certain Hazardous Substances in Electrical and Electronic Equipment).

This product also has the following attributes:

- Lead Free
- Halogen Free (Chlorine, Bromine)
- Antimony Free
- TBBP-A (C₁₅H₁₂Br₄O₂) Free
- PFOS Free
- SVHC Free

Contact Information

For the latest specifications, additional product information, worldwide sales and distribution locations, and information about TriQuint:

Web: www.triquint.com **Tel:** +1.503.615.9000
Email: info-sales@triquint.com **Fax:** +1.503.615.8902

For technical questions and application information:

Email: sjapplications.engineering@triquint.com

Important Notice

The information contained herein is believed to be reliable. TriQuint makes no warranties regarding the information contained herein. TriQuint assumes no responsibility or liability whatsoever for any of the information contained herein. TriQuint assumes no responsibility or liability whatsoever for the use of the information contained herein. The information contained herein is provided "AS IS, WHERE IS" and with all faults, and the entire risk associated with such information is entirely with the user. All information contained herein is subject to change without notice. Customers should obtain and verify the latest relevant information before placing orders for TriQuint products. The information contained herein or any use of such information does not grant, explicitly or implicitly, to any party any patent rights, licenses, or any other intellectual property rights, whether with regard to such information itself or anything described by such information.

TriQuint products are not warranted or authorized for use as critical components in medical, life-saving, or life-sustaining applications, or other applications where a failure would reasonably be expected to cause severe personal injury or death.



Стандарт Электрон Связь

Мы молодая и активно развивающаяся компания в области поставок электронных компонентов. Мы поставляем электронные компоненты отечественного и импортного производства напрямую от производителей и с крупнейших складов мира.

Благодаря сотрудничеству с мировыми поставщиками мы осуществляем комплексные и плановые поставки широчайшего спектра электронных компонентов.

Собственная эффективная логистика и склад в обеспечивает надежную поставку продукции в точно указанные сроки по всей России.

Мы осуществляем техническую поддержку нашим клиентам и предпродажную проверку качества продукции. На все поставляемые продукты мы предоставляем гарантию .

Осуществляем поставки продукции под контролем ВП МО РФ на предприятия военно-промышленного комплекса России , а также работаем в рамках 275 ФЗ с открытием отдельных счетов в уполномоченном банке. Система менеджмента качества компании соответствует требованиям ГОСТ ISO 9001.

Минимальные сроки поставки, гибкие цены, неограниченный ассортимент и индивидуальный подход к клиентам являются основой для выстраивания долгосрочного и эффективного сотрудничества с предприятиями радиоэлектронной промышленности, предприятиями ВПК и научно-исследовательскими институтами России.

С нами вы становитесь еще успешнее!

Наши контакты:

Телефон: +7 812 627 14 35

Электронная почта: sales@st-electron.ru

Адрес: 198099, Санкт-Петербург,
Промышленная ул, дом № 19, литера Н,
помещение 100-Н Офис 331