

SD356EVK Evaluation Kit Board for LMH0356 SDI Reclocker User Manual

National Semiconductor
EVK User Manual



Introduction

The LMH0356 Serial Digital Interface (SDI) reclocker is designed to recover a clean clock from a serial digital video signal which may be contaminated by jitter and to resynchronize the input video data to the recovered clean clock. The LMH0356 SDI reclocker accepts signals conforming to standards SMPTE 259M (C), SMPTE 292M, and SMPTE 424M.

The LMH0356 includes, in addition to the reclocking circuitry, an input 4-channel multiplexer which permits selection for reclocking of any of four serial digital video signals at the inputs of the LMH0356. It also includes fixed equalizers on its inputs designed to reduce the inter-symbol interference (ISI) generated by dispersive PC board traces between the serial digital video source and the reclocker inputs. The LMH0356 fixed equalizers are designed to compensate for the frequency-dependent loss of up to 30 inches of FR-4 PC board trace.

The SD356EVK is a PC board designed to aid in the evaluation of the performance characteristics of the LMH0356 reclocker. The SD356EVK PC board is fabricated with FR-4 PC board material. The inputs and outputs of the LMH0356 are connected to the SMA coaxial connectors on the board using controlled-impedance 50 Ω single-ended and 100 Ω differential PC board traces.

This instruction manual describes the features of the SD356EVK. It should be used in conjunction with the LMH0356 SDI reclocker data sheet. Schematics and PC board layout drawings for the SD356EVK board are included separately. In addition, board fabrication files are available on request. Contact your local National Semiconductor representative.

PC Board Features

The SD356EVK is shown in Figure 1. The features of the board are described in the sections that follow.

General Description

The SD356EVK is a four-layer PC board fabricated using FR-4. The layer stackup is shown in drawing number 980600057-001. As the drawing indicates, the nominal board thickness is .062 inches. The board includes internal ground and power supply planes. The ground plane is the second layer of the board (underneath the top layer) and is the reference for the controlled-impedance traces on the top layer.

The SD356EVK is fabricated using Pb-free solder and components and is comprised of RoHS-compliant materials.

SDI Input and Output Connectors

The SDI input and output connectors are 50 Ω SMA female coaxial connectors (jacks). These connectors will mate non-destructively with 50 Ω SMA male coaxial connectors (plugs). They will also mate non-destructively with 50 Ω APC-3.5 male coaxial connectors and 2.92 mm (K) male coaxial connectors. These connectors will NOT mate to 2.4 mm connectors. Do not attempt to connect 2.4 mm connectors to the SD356EVK PC board. This will damage both the board and the connected device or cable.

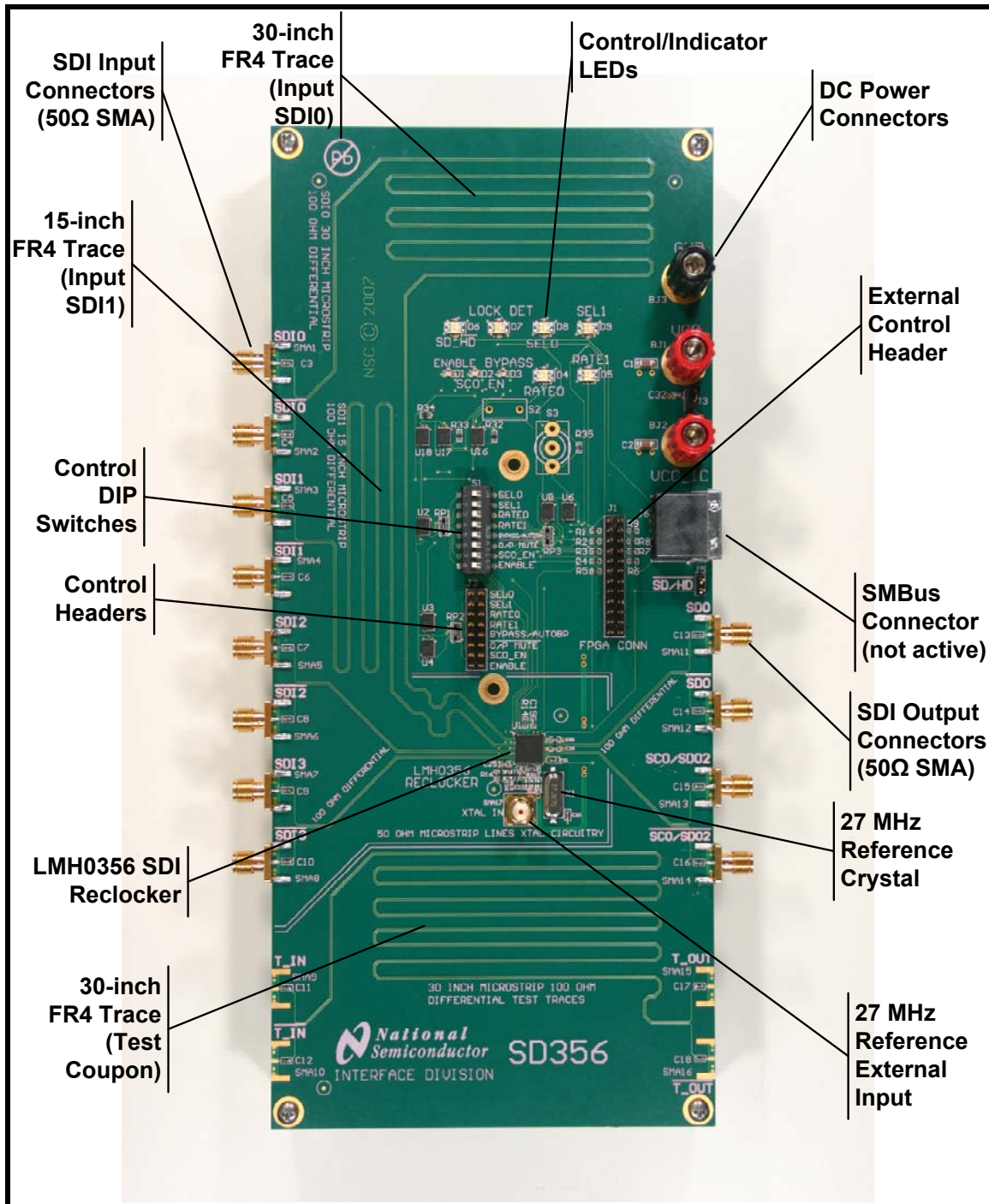

Figure 1. SD356EVK board

Although the SMA coaxial connectors are ruggedized for attachment to the edge of the SD356EVK PC board, they can be damaged by over-tightening them. A standard SMA torque wrench with a torque limitation of 7-10 in-pounds should always be used to connect cables to the connectors on the SD356EVK. Do not allow heavy cables to hang unsupported from the connectors as they may break off the board.

The SDI input and output connectors occur in pairs as the inputs and outputs of the LMH0356 SDI reclocker are differential. It is not necessary to terminate unused inputs. Both the inputs and outputs of the LMH0356 SDI reclocker are internally terminated.

The SD356EVK has two sets of outputs connected to the two outputs of the LMH0356 SDI reclocker. The first set of outputs, labeled SDO, always carry the digital video data signal unless they are muted. If the reclocker is locked and not bypassed, these outputs carry a reclocked version of the input signal. If the reclocker is unlocked or bypassed, these outputs carry an unmodified replica of the input signal. The outputs may be muted by the output mute control described in a later section.

The second set of outputs of the SD356EVK, labeled SCO/SDO2, can be set either to output a copy of the data on the first set of outputs, either reclocked or not as describe above, or to output the recovered clock signal from the LMH0356 SDI reclocker. The clock signal is only available when the LMH0356 SDI reclocker is locked to a valid input signal.

The inputs and outputs of the SD356EVK PC board are AC-coupled with 1 μ F 0402-size coupling capacitors. These capacitors are rated for 10 VDC working voltage. The inputs and outputs of the SD356EVK board may be terminated in any DC voltage that does not exceed this 10 V limit relative to the negative power supply. The coupling capacitors may be replaced with 0402-size 0 Ω resistors for DC-coupled evaluation.

FR-4 Traces

Two of the inputs to the SD356EVK, inputs SDI0 and SDI1, are equipped with long FR-4 test traces. The trace lengths are 30 inches and 15 inches respectively on the two inputs. The other two inputs are coupled to the LMH0356 SDI reclocker through very short FR-4 traces. The FR-4 test traces are meant to demonstrate the action of the input passive equalizers. The input passive equalizers compensate for the ISI introduced by long PC board traces. The SD356EVK demonstrates that the performance of the LMH0356 SDI reclocker is unaffected by up to 30 inches of lossy FR-4 trace on its inputs.

The SD356EVK also includes a 30 inch FR-4 test trace which can be used to evaluate the ISI effect introduced by such a trace. If desired, connectors can be soldered on to this test trace and the ISI can be measured by external test equipment. If this is desired, the same connectors used on the inputs and outputs of the SD356EVK may be used. These connectors are specified in the bill of materials for the SD356EVK.

DC Power Connectors

DC power is applied to the SD356EVK by means of standard .175-inch diameter binding posts. Three power supply terminals are provided. The first is a common ground, to which the negative supply voltage should be connected. This is the black binding post on the board. The two red binding posts on the board are meant to provide 3.3 VDC to 1) the LMH0356 SDI reclocker alone, and 2) the remainder of the circuitry on the SD356EVK board. The dual-supply configuration permits measurement of the current drawn by the LMH0356 SDI reclocker independent of the other devices on the board if desired. The two supplies may be connected together if desired using either an external jumper or the onboard header between the 3.3 V power supply terminals.

The power supply is not regulated on the SD356EVK board so the effects of power supply variations can be evaluated. It is recommended that the maximum supply voltage rating of the LMH0356 (4 VDC) not be exceeded.

The LMH0356 SDI reclocker can be powered-down using its enable feature. This feature is accessible through the control inputs described in the next section. The dual-supply configuration of the SD356EVK can be used to observe the effect on supply current of powering down the LMH0356.

Controls and Indicators

The control lines of the LMH0356 SDI reclocker can be controlled by various means using the SD356EVK. The primary method for controlling these lines is the DIP switches located on the SD356EVK board. The DIP switches are labeled according to their function. When the switch actuator is pushed to the right

(seen from the top), the switch is closed. The schematic for the board indicates the functions of each switch. The switch functionality is summarized in Table 1 below.

Two headers are also provided for operating the control lines of the LMH0356 SDI reclocker. The first is located immediately below the DIP switches. This header is meant to be used with two-pin jumpers and provides parallel functionality to the DIP switches. When a jumper is installed on the header it overrides the function of the equivalent DIP switch.

The second header is located to the right of the DIP switches. This header is meant to provide access for remote control of the LMH0356 SDI reclocker. When this header is used the DIP switches should all be set in the open position and no jumpers should be installed on the control header. The connections for this header are described in the schematic for the SD356EVK PC board. It is recommended that this header only be used for advanced control applications and only by users familiar with the operation of the LMH0356 SDI reclocker.

LED indicators are provided near the top of the board to indicate the state of the control inputs and the indicator outputs of the LMH0356 SDI reclocker. The LED states and their meanings are summarized in Table 1.

Table 1. Control and Indicator Function Summary

Function	Switch	Indicator	Switch "On" Function and Indication	Switch "Off" Function and Indication
Input Select	Sel0 Sel1	Sel0 Sel1	Select line pulled to logic 1 Indicator light turns red	Select line pulled to logic 0 Indicator light turns green
Rate Select	Rate0 Rate1	Rate0 Rate1	Rate line pulled to logic 1 Indicator light turns red	Rate line pulled to logic 0 Indicator light turns green
Bypass/Autobypass	Bypass/Autobypass	Bypass	LMH0356 reclocker forced to bypass mode Indicator on (red)	LMH0356 reclocker in normal (autobypass) mode Indicator off
Output Mute	OP Mute	None	LMH0356 reclocker output is muted	LMH0356 reclocker output is active
Serial Clock Output Enable	SCO_EN	SCO_EN	Second output of the SD356EVK outputs the recovered clock Indicator on (green)	Second output of the SD356EVK outputs a copy of the reclocked data Indicator off
Chip Enable	ENABLE	ENABLE	LMH0356 is powered up (active) Indicator on (green)	LMH0356 is powered down (inactive) Indicator off
SD/HD Indication	None	SD_HD	Indicator green indicates HD or 3 Gb/s signal or no signal detected	Indicator red indicates SD signal detected
Lock Detection	None	LOCK DET	Indicator on (green) when the LMH0356 reclocker is locked to the incoming signal	Indicator off when the LMH0356 reclocker is not locked to the incoming signal

There is also a header on the right side of the SD356EVK board which is connected to the SD/HD indication of the LMH0356 SDI reclocker. It is meant to control an LMH0302 SDI cable driver. The output polarity of the signal on this header is such that it can be connected directly to the SD/HD control input of the LMH0302 cable driver. The header on the SD356EVK board facilitates this connection.

27 MHz Reference

The SD356EVK includes an on-board 27-MHz reference crystal. In the normal configuration of the board this crystal is active. The LMH0356 SDI reclocker includes a crystal driver circuit that produces the 27-MHz reference clock using this crystal.

The SD356EVK also includes a connector for inputting an external 27-MHz reference if desired. In order to disable the on-board crystal a 0 Ω resistor indicated on the schematic for the board must be removed. This permits evaluation of the operation of the LMH0356 SDI reclocker with an external reference.

SMBus Connector

The LMH0356 SDI reclocker can be controlled via a 2-wire bus very similar to the standard SMBus. This mode of operation is reserved for factory use only.

Typical Output Waveform

A test waveform can be readily generated and used to verify proper operation of the SD356EVK. In order to generate this output waveform, the following setup procedure should be used.

Test Setup

The test setup used for testing the SD356EVK board is shown in Figure 2. Note that the test setup includes a SyntheSys Research BERTScope as a signal generator, eye diagram measurement device, and bit error rate test receiver. Other equivalent instruments could be used for these measurements. The equipment used for testing the SD356EVK is listed in Table 2.

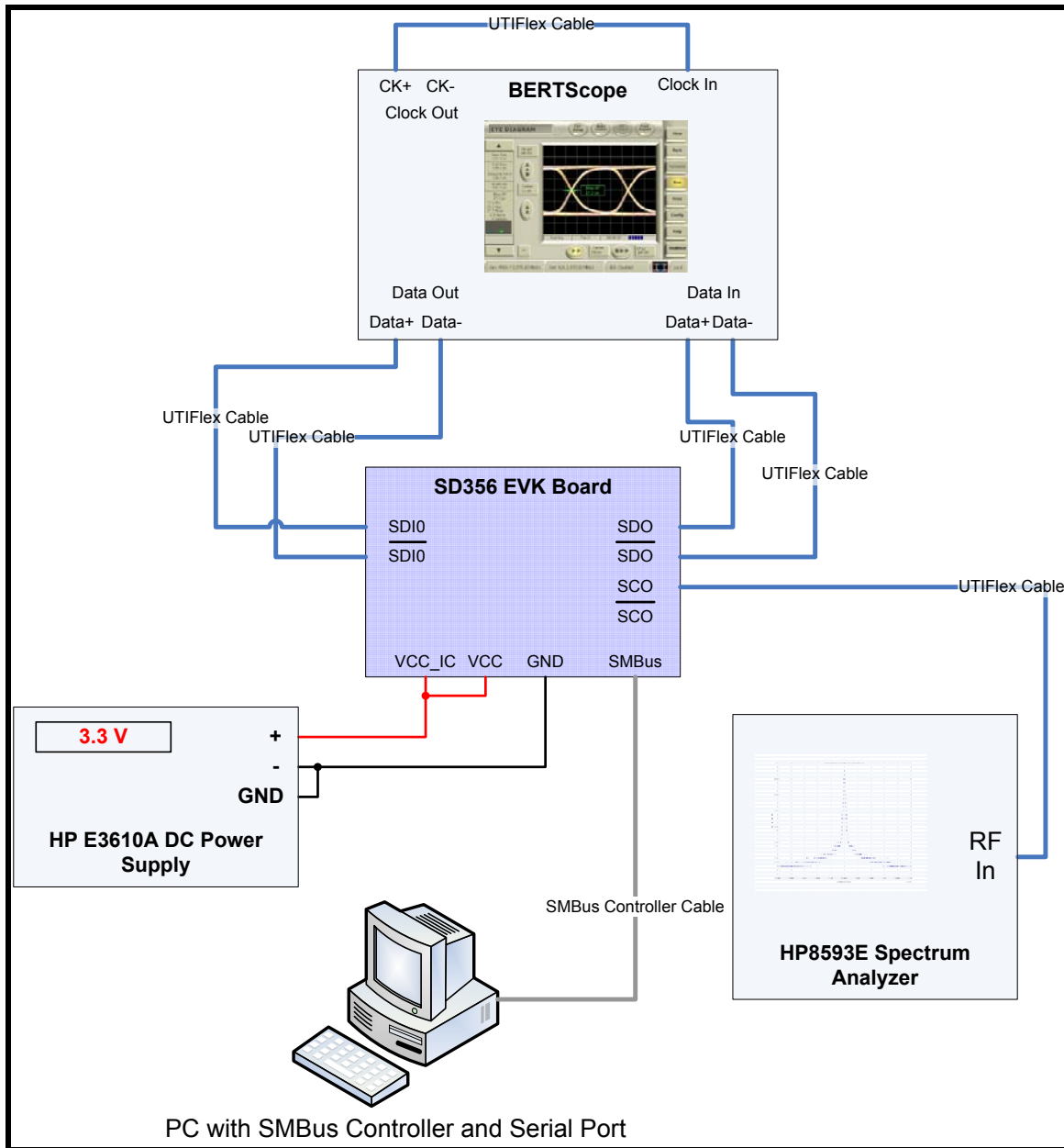

Figure 2. Test setup for the SD356EVK board.

To generate the example output eye diagram shown, the PC and the spectrum analyzer are not required. These items are used for other elements of the test procedure.

Table 2. Test Equipment and Material Required

Description	Suggested Equipment		
	Manufacturer	Equipment Name	Model Number
Bit Error Rate Test Set with the following: 3 Gb/s Serial Data Capability Jitter Injection Capability Eye Diagram and Jitter Measurement Capability	SyntheSys Research Agilent Technologies	BERTScope J-Bert	12500B N4903A
DC Power Supply 3.3 V @ 0.5 A	Hewlett-Packard	DC Power Supply	E3610A
Spectrum Analyzer with minimum 3 GHz bandwidth	Hewlett-Packard	Portable Spectrum Analyzer	8593E
Six (6) each UTIFlex coaxial cables SMA connectors 36 inch length	Micro-Coax Inc.	UTIFlex	UFB205A-0-0360-000000

Test Equipment Settings

The example eye diagram shown is for a 1.4835 Gb/s HD SDI signal. Similar eye diagrams can be obtained at 2.97 Gb/s and at 270 Mb/s by changing the bit rate setting on the signal generator.

Generator Setting	Value	Comments
Data Rate	1.4835 Gb/s	Any valid SMPTE data rate supported by the LMH0356 SDI reclocker can be used. These rates are 270 Mb/s, 1.485 Gb/s, 1.4835 Gb/s, 2.967 Gb/s, and 2.97 Gb/s
Data Pattern	PRBS-7	This is a standard pseudorandom pattern 127 bits long. Other pseudorandom patterns can be used as well as live SDI video patterns (which are not, in general, pseudorandom) or the SMPTE pathological data sequences.
Output Amplitude	200 mV	This is the specified lower limit for the input differential voltage for the LMH0356. Higher input voltages can be used. A differential input voltage of 200 mV peak-to-peak means that each of the two inputs swings 100 mV peak-to-peak.
Output Offset	0 V	The inputs of the SD356EVK are AC coupled so the output offset of the generator does not matter unless it overstresses the input coupling capacitors. Do not exceed 4 V output offset on the generator to avoid this.
Injected Jitter	0 UI	If the signal generator is capable of injecting controlled jitter, the jitter tolerance of the LMH0356 may be evaluated using the SD356EVK board. Typical settings used for jitter tolerance testing on the SD36EVK board are 0.7 UI jitter amplitude at 5 MHz and 10 MHz jitter frequencies.

SD356EVK Board Settings

Essentially all of the settings of the SD356EVK are set to their nominal values to produce the typical eye diagram shown in Figure 3.

Table 3. Control Settings and Indicator States to Produce Typical Eye Diagram

Function	Switch	Indicator	Switch and Indicator State	Comments
Input Select	Sel0 Sel1	Sel0 Sel1	Both switches off Both indicator lights green	This is the setting for selecting input SDI0. Other selection settings can be used with other SDI inputs.
Rate Select	Rate0 Rate1	Rate0 Rate1	Both switches off Both indicator lights green	This is the setting for automatic rate detect. The rate selection switches can also be set to match the data rate input. For a 1.4835 Gb/s signal as described here, Rate0 can be off and Rate 1 on.
Bypass/Autobypass	Bypass/Autobypass	Bypass	Switch off Indicator light off	LMH0356 reclocker in normal (autobypass) mode.
Output Mute	OP Mute	None	Switch off	LMH0356 reclocker output is active.
Serial Clock Output Enable	SCO_EN	SCO_EN	Switch off Indicator light off	This test will produce the same results regardless of the state of the SCO_EN.
Chip Enable	ENABLE	ENABLE	Switch of Indicator light on	LMH0356 is powered up.
SD/HD Indication	None	SD_HD	Indicator green, indicating HD or 3 Gb/s signal or no signal detected	The indicator will be red if a 270 Mb/s signal is used.
Lock Detection	None	LOCK DET	Indicator on (green), indicating that the LMH0356 reclocker is locked to the incoming signal	The indicator will be off if a non-supported data rate is used.

Sample Output Eye Diagram

The output eye diagram shown in Figure 3 is typical of the output eye diagrams obtained during testing of the SD356EVK.

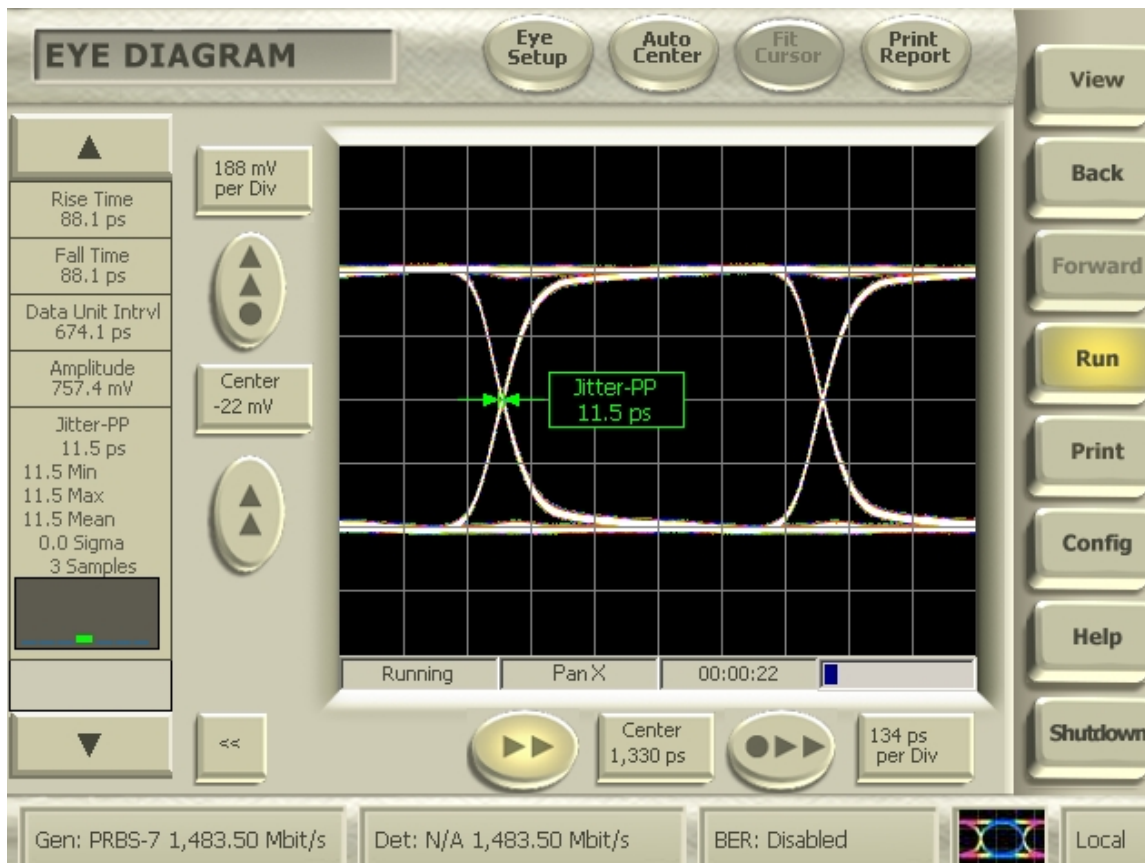

Figure 3. Typical output eye diagram for 1.4835 Gb/s.

Summary

The SD356EVK is a simplified four-layer PC board designed to facilitate the evaluation of the LMH0356 SDI reclocker. In concept it is a simple input/output board with the LMH0356 SDI reclocker in the signal path. This manual has described the features of the PC board and its operation.

Please also see the SDI Feature site at:

www.national.com/sdi

IMPORTANT NOTICE

Texas Instruments Incorporated and its subsidiaries (TI) reserve the right to make corrections, modifications, enhancements, improvements, and other changes to its products and services at any time and to discontinue any product or service without notice. Customers should obtain the latest relevant information before placing orders and should verify that such information is current and complete. All products are sold subject to TI's terms and conditions of sale supplied at the time of order acknowledgment.

TI warrants performance of its hardware products to the specifications applicable at the time of sale in accordance with TI's standard warranty. Testing and other quality control techniques are used to the extent TI deems necessary to support this warranty. Except where mandated by government requirements, testing of all parameters of each product is not necessarily performed.

TI assumes no liability for applications assistance or customer product design. Customers are responsible for their products and applications using TI components. To minimize the risks associated with customer products and applications, customers should provide adequate design and operating safeguards.

TI does not warrant or represent that any license, either express or implied, is granted under any TI patent right, copyright, mask work right, or other TI intellectual property right relating to any combination, machine, or process in which TI products or services are used. Information published by TI regarding third-party products or services does not constitute a license from TI to use such products or services or a warranty or endorsement thereof. Use of such information may require a license from a third party under the patents or other intellectual property of the third party, or a license from TI under the patents or other intellectual property of TI.

Reproduction of TI information in TI data books or data sheets is permissible only if reproduction is without alteration and is accompanied by all associated warranties, conditions, limitations, and notices. Reproduction of this information with alteration is an unfair and deceptive business practice. TI is not responsible or liable for such altered documentation. Information of third parties may be subject to additional restrictions.

Resale of TI products or services with statements different from or beyond the parameters stated by TI for that product or service voids all express and any implied warranties for the associated TI product or service and is an unfair and deceptive business practice. TI is not responsible or liable for any such statements.

TI products are not authorized for use in safety-critical applications (such as life support) where a failure of the TI product would reasonably be expected to cause severe personal injury or death, unless officers of the parties have executed an agreement specifically governing such use. Buyers represent that they have all necessary expertise in the safety and regulatory ramifications of their applications, and acknowledge and agree that they are solely responsible for all legal, regulatory and safety-related requirements concerning their products and any use of TI products in such safety-critical applications, notwithstanding any applications-related information or support that may be provided by TI. Further, Buyers must fully indemnify TI and its representatives against any damages arising out of the use of TI products in such safety-critical applications.

TI products are neither designed nor intended for use in military/aerospace applications or environments unless the TI products are specifically designated by TI as military-grade or "enhanced plastic." Only products designated by TI as military-grade meet military specifications. Buyers acknowledge and agree that any such use of TI products which TI has not designated as military-grade is solely at the Buyer's risk, and that they are solely responsible for compliance with all legal and regulatory requirements in connection with such use.

TI products are neither designed nor intended for use in automotive applications or environments unless the specific TI products are designated by TI as compliant with ISO/TS 16949 requirements. Buyers acknowledge and agree that, if they use any non-designated products in automotive applications, TI will not be responsible for any failure to meet such requirements.

Following are URLs where you can obtain information on other Texas Instruments products and application solutions:

Products

Audio	www.ti.com/audio
Amplifiers	amplifier.ti.com
Data Converters	dataconverter.ti.com
DLP® Products	www.dlp.com
DSP	dsp.ti.com
Clocks and Timers	www.ti.com/clocks
Interface	interface.ti.com
Logic	logic.ti.com
Power Mgmt	power.ti.com
Microcontrollers	microcontroller.ti.com
RFID	www.ti-rfid.com
OMAP Mobile Processors	www.ti.com/omap
Wireless Connectivity	www.ti.com/wirelessconnectivity

Applications

Automotive and Transportation	www.ti.com/automotive
Communications and Telecom	www.ti.com/communications
Computers and Peripherals	www.ti.com/computers
Consumer Electronics	www.ti.com/consumer-apps
Energy and Lighting	www.ti.com/energy
Industrial	www.ti.com/industrial
Medical	www.ti.com/medical
Security	www.ti.com/security
Space, Avionics and Defense	www.ti.com/space-avionics-defense
Video and Imaging	www.ti.com/video

TI E2E Community Home Page

e2e.ti.com

Mailing Address: Texas Instruments, Post Office Box 655303, Dallas, Texas 75265
Copyright © 2012, Texas Instruments Incorporated



Стандарт Электрон Связь

Мы молодая и активно развивающаяся компания в области поставок электронных компонентов. Мы поставляем электронные компоненты отечественного и импортного производства напрямую от производителей и с крупнейших складов мира.

Благодаря сотрудничеству с мировыми поставщиками мы осуществляем комплексные и плановые поставки широчайшего спектра электронных компонентов.

Собственная эффективная логистика и склад в обеспечивает надежную поставку продукции в точно указанные сроки по всей России.

Мы осуществляем техническую поддержку нашим клиентам и предпродажную проверку качества продукции. На все поставляемые продукты мы предоставляем гарантию .

Осуществляем поставки продукции под контролем ВП МО РФ на предприятия военно-промышленного комплекса России , а также работаем в рамках 275 ФЗ с открытием отдельных счетов в уполномоченном банке. Система менеджмента качества компании соответствует требованиям ГОСТ ISO 9001.

Минимальные сроки поставки, гибкие цены, неограниченный ассортимент и индивидуальный подход к клиентам являются основой для выстраивания долгосрочного и эффективного сотрудничества с предприятиями радиоэлектронной промышленности, предприятиями ВПК и научно-исследовательскими институтами России.

С нами вы становитесь еще успешнее!

Наши контакты:

Телефон: +7 812 627 14 35

Электронная почта: sales@st-electron.ru

Адрес: 198099, Санкт-Петербург,
Промышленная ул, дом № 19, литера Н,
помещение 100-Н Офис 331