



# MAX19586/MAX19588 Evaluation Kits

## General Description

The MAX19586/MAX19588 evaluation kits (EV kits) are fully assembled and tested PCBs that contain all the components necessary to evaluate the performance of the MAX19586 and MAX19588. The MAX19586 is a 16-bit, 80Msps analog-to-digital converter (ADC), while the MAX19588 is a 16-bit, 100Msps ADC. The MAX19586/MAX19588 EV kits can accept a differential or single-ended analog input. For applications with a single-ended signal source, the MAX19586/MAX19588 EV kits feature an on-board transformer that converts this signal to the required differential signal. The digital outputs produced by the MAX19586/MAX19588 can be captured with a logic analyzer or data-acquisition system. The EV kits operate from a 3.3V and a 1.8V power supply.

## Part Selection Table

PART NUMBER	BITS	SPEED (Msps)
MAX19586ETN+	16	80
MAX19588ETN+		100

## Features

- ◆ Fully Assembled and Tested
- ◆ Up to 80Msps/100Msps Sampling Rate
- ◆ Single-Ended-to-Differential Clock Conversion Circuitry
- ◆ Configurable for Differential or Single-Ended Analog Input Signals
- ◆ On-Board Digital Output Buffer
- ◆ Low-Voltage and Low-Power Operation
- ◆ Simplifies Evaluation of the MAX19586/MAX19588

## Ordering Information

PART	TEMP RANGE	IC PACKAGE
MAX19586EVKIT+	0°C to +70°C*	56 Thin QFN-EP**
MAX19588EVKIT+	0°C to +70°C*	56 Thin QFN-EP**

+Denotes a lead-free and RoHS-compliant EV kit.

\*This limited temperature range is for the EV kit PCB only. The MAX19586/MAX19588 IC temperature range is -40°C to +85°C.

\*\*EP = Exposed paddle.

## Component List

DESIGNATION	QTY	DESCRIPTION
C1, C6, C10, C18, C28–C33	10	0.1μF ±10%, 50V X7R ceramic capacitors (0603) TDK C1608X7R1H104K
C2–C5, C8, C9, C11, C12	0	Not installed capacitors (0603)
C13, C14	2	1μF ±10%, 16V X5R ceramic capacitors (0603) TDK C1608X5R1C105K
C19, C22, C25	3	220μF ±20%, 6.3V low-ESR tantalum capacitors (D-case) AVX TPSD227M006R0100
C20, C23, C26	3	47μF ±20%, 6.3V X5R ceramic capacitors (1210) TDK C3225X5R0J476M
C21, C24, C27	3	2.2μF ±20%, 6.3V X5R ceramic capacitors (0603) TDK C1608X5R0J225M

DESIGNATION	QTY	DESCRIPTION
C34, C38, C39, C40	4	0.01μF ±10%, 16V X7R ceramic capacitors (0306) TDK C0816X7R1C103K
C35, C36, C41, C42, C43	5	0.1μF ±20%, 16V X7R ceramic capacitors (0306) TDK C0816X7R1C104M
C37	1	0.1μF ±10%, 6.3V X5R ceramic capacitor (0201) TDK C0603X5R0J104K Murata GRM33R60J104K
D1	1	15mA, 70V, dual Schottky diode (SOT23) Diodes Inc. BAS70-04 or Central Semiconductor CMPD6263S
CLOCK, INPUT+	2	SMA PC mount connectors
INPUT-	0	Not installed SMA PC mount connector
J1, J2	2	2-pin headers
J3, J4	2	2 x 8-pin headers



# MAX19586/MAX19588 Evaluation Kits

## Component List (continued)

DESIGNATION	QTY	DESCRIPTION
J5	1	2 x 20-pin header
J6	1	PCB pin strip, 6 pins, 5mm pitch, 250V, 10A
L1, L2, L3	3	EMI filters (1806) Murata NFM41PC204F1H3B
L4	0	Not installed, high-Q chip inductor (0603)
R1–R5, R8, R9, R13	0	Not installed, resistors (0603)
R6, R7, R10, R11	4	49.9Ω ±1% resistors (0603)
R12	1	10kΩ ±1% resistor (0603)
R14	1	120Ω ±5% resistor (0603)
R15	1	49.9Ω ±1% resistor (0402)
RA1, RA2	2	120Ω ±5% resistor arrays Panasonic EXB-2HV-121J

DESIGNATION	QTY	DESCRIPTION
T1, T3	2	1:2 RF transformers Mini-Circuits ADT2-1T+
T2	1	1:1 RF transformer Mini-Circuits T1-1T-KK81+
U1	1	<b>See the <i>EV Kit-Specific Component List</i> section</b>
U2	1	Low-voltage, 22-bit register (64-pin TSSOP) Fairchild 74VCX16722MTD
U3	1	TinyLogic ULP-A inverter with Schmitt trigger input (SC70-5) Fairchild NC7SV14P5X
—	1	PC board terminal block (plug onto the J6 pin strip) 6 pins, 5mm pitch, 250V, 10A
—	1	PCB: MAX19586/MAX19588 evaluation kits+

## EV Kit-Specific Component List

EV KIT PART NUMBER	REFERENCE DESIGNATOR	DESCRIPTION
MAX19586EVKIT+	U1	MAX19586ETN+ (56-pin, 8mm x 8mm x 0.8mm Thin QFN-EP**)
MAX19588EVKIT+		MAX19588ETN+ (56-pin, 8mm x 8mm x 0.8mm Thin QFN-EP**)

\*\*EP = Exposed paddle.

## Component Suppliers

SUPPLIER	PHONE	WEBSITE
AVX Corp.	843-946-0238	www.avxcorp.com
Central Semiconductor Corp.	631-435-1110	www.centralsemi.com
Diodes Inc.	805-446-4800	www.diodes.com
Fairchild Semiconductor	888-522-5372	www.fairchildsemi.com
Mini-Circuits	718-934-4500	www.minicircuits.com
Murata Mfg. Co., Ltd.	770-436-1300	www.murata.com
Panasonic Corp.	714-373-7366	www.panasonic.com
TDK Corp.	847-803-6100	www.component.tdk.com

**Note:** Indicate that you are using the MAX19586/MAX19588 when contacting these component suppliers.

# MAX19586/MAX19588 Evaluation Kits

## Quick Start

### Recommended Equipment

- DC power supplies:

Analog (AVDD)	3.3V, 500mA
Digital (DVDD)	1.8V, 100mA
Logic (VL)	1.8V, 100mA
- Signal generator with low phase noise and low jitter for clock input (e.g., HP/Agilent 8644B)
- Signal generator for analog signal input (e.g., HP/Agilent 8644B)
- Analog bandpass filters for input signal and clock signal (e.g., Allen Avionics, K&L Microwave)
- Logic analyzer or data-acquisition system (e.g., HP/Agilent 16500C, Tektronix TLA621)

**Note:** The *Quick Start* procedure in this section only provides a quick functional check for the MAX19586/MAX19588 EV kits. To verify the full dynamic performance of the MAX19586/MAX19588, refer to the *Testing the MAX1958\_* sections in the respective IC data sheets.

### Procedure

The MAX19586/MAX19588 EV kits are fully assembled and tested PCBs. Follow the steps below to verify board operation (Figure 1). **Caution: Do not turn on power supplies or enable signal generators until all connections are completed.**

- 1) Connect the output of the clock signal generator to the input of the clock bandpass filter.
- 2) Connect the output of the clock bandpass filter to the CLOCK SMA connector on the EV kit.
- 3) Connect the output of the analog signal generator to the input of the analog bandpass filter.
- 4) Connect the output of the analog bandpass filter to the INPUT+ SMA connector on the EV kit.
- 5) Connect header J5 to the HP/Agilent logic analyzer. Alternatively, for Tektronix-type logic analyzers, connect to headers J1, J3, and J4. To capture the DOR bit (data over-range), connect a free logic analyzer data line to header J2. See the *Digital Output Signals* section in this document for bit locations and all header designations.
- 6) Connect the 3.3V, 500mA power supply to the AVDD terminal. Connect the ground terminal of this supply to the GND terminal.
- 7) Connect a 1.8V, 100mA power supply to the DVDD terminal. Connect the ground terminal of this supply to the GND terminal.
- 8) Connect another 1.8V, 100mA power supply to the VL terminal. Connect the ground terminal of this supply to the corresponding GND terminal.
- 9) Turn on the power supplies.
- 10) Enable the signal generators. Set the clock signal generator output power to +19dBm and the frequency (f<sub>CLK</sub>) to 80MHz for the MAX19586 EV kit, or 100MHz for the MAX19588 EV kit. Set the analog input signal generator output to the desired frequency and amplitude. For coherent data capture, the signal generators should be phase-locked. Adjust the analog input signal level to overcome cable and filter losses that may exist in the signal's input path. Note that the ADC full scale is +9.1dBm.
- 11) Enable the logic analyzer and start collecting data.

# MAX19586/MAX19588 Evaluation Kits

## Detailed Description

The MAX19586/MAX19588 EV kits are fully assembled and tested PCBs that contain all the components necessary to evaluate the performance of the MAX19586 or the MAX19588 ADCs. Digital data generated by the ADCs is captured on a 16-bit bus (+ DOR bit). The EV kits can be evaluated with a maximum clock frequency (f<sub>CLK</sub>) of 80MHz for the MAX19586, or 100Msps for the MAX19588.

The EV kits are designed as six-layer PCBs to optimize the performance of the converter. The EV kits are specified to have 3.3V and 1.8V power supplies applied to the analog (AVDD) and digital (DVDD, VL) power planes, respectively.

The digital outputs are available on connectors J5 or J3 and J4. J5 is a 40-pin connector, which can directly interface with a user-provided logic analyzer or data-acquisition system. The digital output clock signal, which is used to synchronize the output data to the logic analyzer, is available at the CLKO pins on J5-3 and J1-1.

## Power Supplies

The MAX19586/MAX19588 EV kits require separate analog and digital power supplies. A 3.3V power supply is used to power the analog portion of the ADC. Two separate 1.8V power supplies are recommended: DVDD powers the digital portion of the MAX19586/MAX19588, and VL powers the buffer/driver U2.

## Reference Voltage

The full-scale range for the MAX19586/MAX19588 is set to 2.56V<sub>p-p</sub> by an internal reference voltage. The MAX19586/MAX19588's internal reference voltage is 1.28V, and can be monitored at the REFOUT pad on the EV kit. To use the internal reference voltage, the reference input (REFIN) must be connected to the reference output (REFOUT) through resistor R12.

The MAX19586/MAX19588 EV kits also provide a REFIN pad, allowing an external reference source to be connected to the ADC. An external reference source can be in the range of 1.28V ±10%.

## Clock

A user-provided single-ended clock signal is converted to a differential clock signal through transformer T3. To reduce clock jitter, the clock signal should have high slew rates at its zero crossings. A large clock signal amplitude can be used to maximize the slew rate at its zero crossings. Diode D1 limits the differential signal swing at the clock input when a large clock signal is used to maximize the slew rate. The MAX19586/MAX19588 EV kits are tested with a +16dBm to +19dBm clock signal, with about 6dB loss in the bandpass filter that follows the clock signal generator.

## Analog Input Signal

The MAX19586/MAX19588 require a differential analog input signal of less than or equal to +9.1dBm (2.56V<sub>p-p</sub> into 100Ω). The EV kits feature on-board transformer

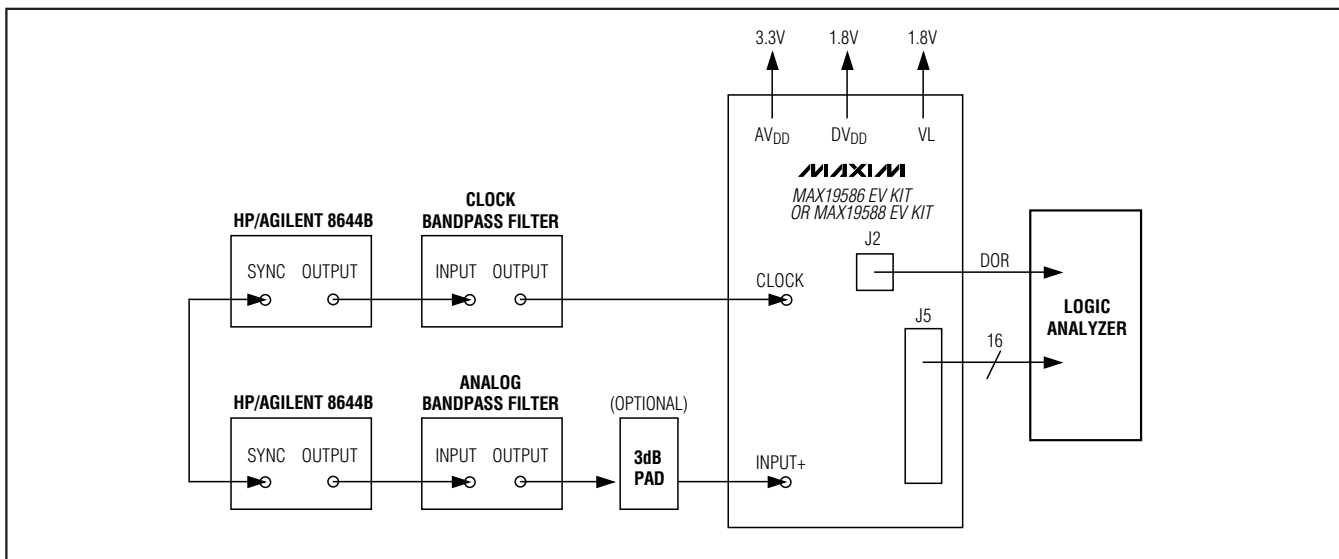

Figure 1. MAX19586/MAX19588 EV Kits Quick Start Setup and Connections

# MAX19586/MAX19588 Evaluation Kits

**Evaluate: MAX19586/MAX19588**

T1 that converts the output of a user-provided single-ended signal to a differential signal for the ADC. Transformer T1 has a primary-to-secondary turns ratio of 1:1.414. Therefore, the single-ended signal should have a power level of less than or equal to +9.1dBm (1.81V<sub>P-P</sub> into 50Ω). Cable and bandpass filter losses affect the amplitude of the received signal at the ADC. Therefore, account for these losses when configuring the signal input generator amplitude.

The EV kits accept a fully differential input signal after making the following modifications:

- Cut the trace between resistor R1 PCB pads.
- Remove transformers T1 and T2.
- Install a 0.1μF (0603) ceramic capacitor on C2.
- Install 0Ω (0603) resistors on R2, R3, R4, and R5.
- Install an SMA connector on the INPUT- PCB footprint.

## Digital Output Signals

The MAX19586/MAX19588 feature a 16-bit, parallel, CMOS-compatible digital output bus and a DOR bit. The digital outputs of the ADC and the DOR bit are

applied to a latch that is capable of driving large capacitive loads that may be present at the logic analyzer connection. The outputs of the buffer are connected to two sets of connectors. The first set of connectors includes J1 for the digital output clock signal, J2 for the DOR bit, J3 and J4 for the digital output signals. This set of connectors accommodates the data-acquisition and logic-analyzer systems such as Tektronix's TLA621. The second set of connectors consists of a single 40-pin header, J5, which provides all signals, except for the DOR bit, for logic-analyzer systems such as HP/Agilent 16500C. See Table 1 for headers J1–J5 bit locations.

**Note that a poor-quality connection may lead to apparent performance degradation. To optimize dynamic performance, avoid using “flying” (or individual) lead logic-analyzer probes for collecting data from the MAX19586/MAX19588 EV kits.**

**Table 1. Digital Output Bit Locations**

BIT	HEADERS J1–J4	HEADER J5
CLKO	J1-1	J5-3
DOR	J2-1	—
D15	J3-1	J5-7
D14	J3-3	J5-9
D13	J3-5	J5-11
D12	J3-7	J5-13
D11	J3-9	J5-15
D10	J3-11	J5-17
D9	J3-13	J5-19
D8	J3-15	J5-21
D7	J4-1	J5-23
D6	J4-3	J5-25
D5	J4-5	J5-27
D4	J4-7	J5-29
D3	J4-9	J5-31
D2	J4-11	J5-33
D1	J4-13	J5-35
D0	J4-15	J5-37

**Note:** All even numbered pins are connected to ground.

# Evaluate: MAX19586/MAX19588

## MAX19586/MAX19588 Evaluation Kits

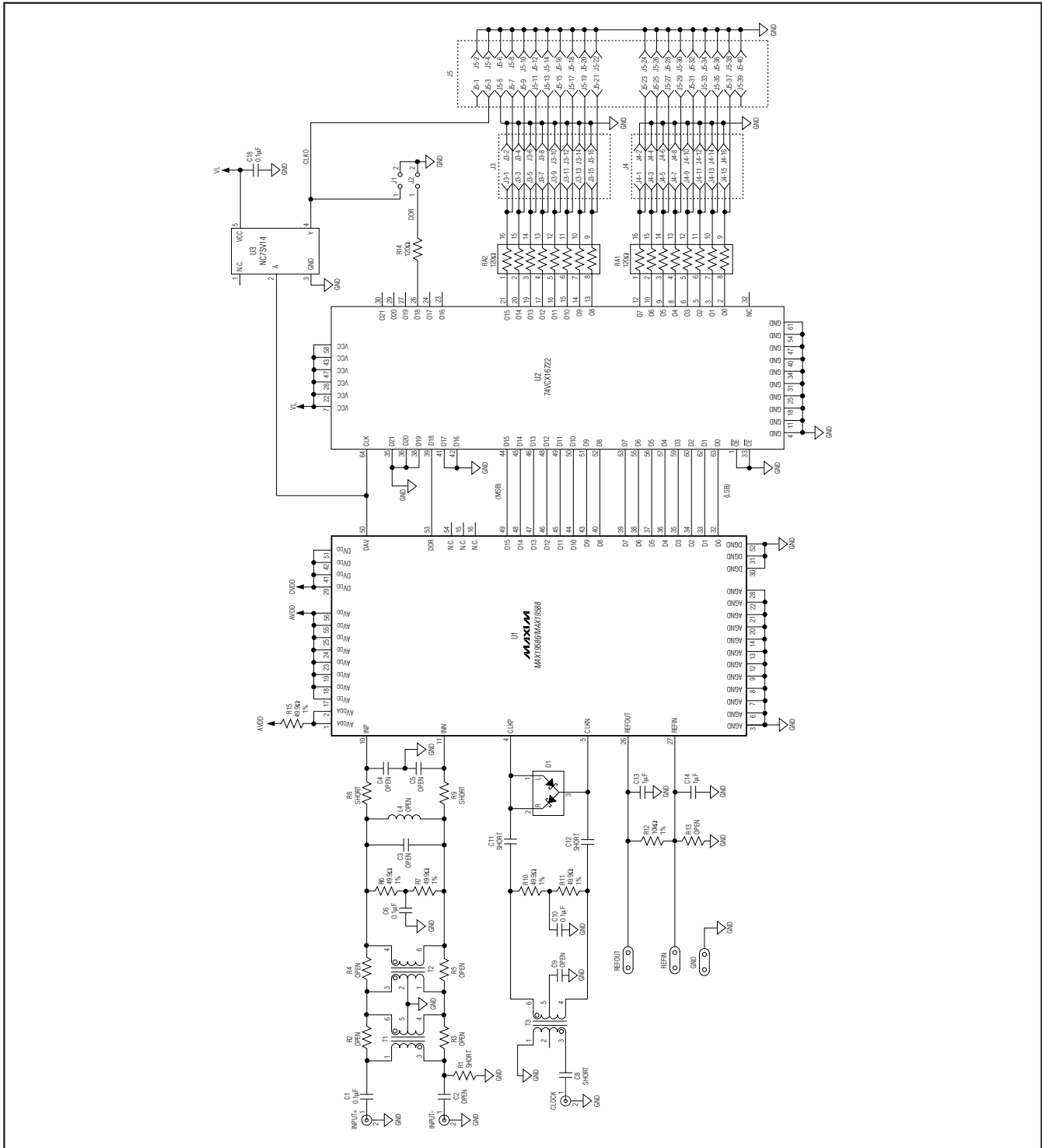

Figure 2a. MAX19586/MAX19588 EV Kits Schematic (Sheet 1 of 2)

# MAX19586/MAX19588 Evaluation Kits

Evaluate: MAX19586/MAX19588

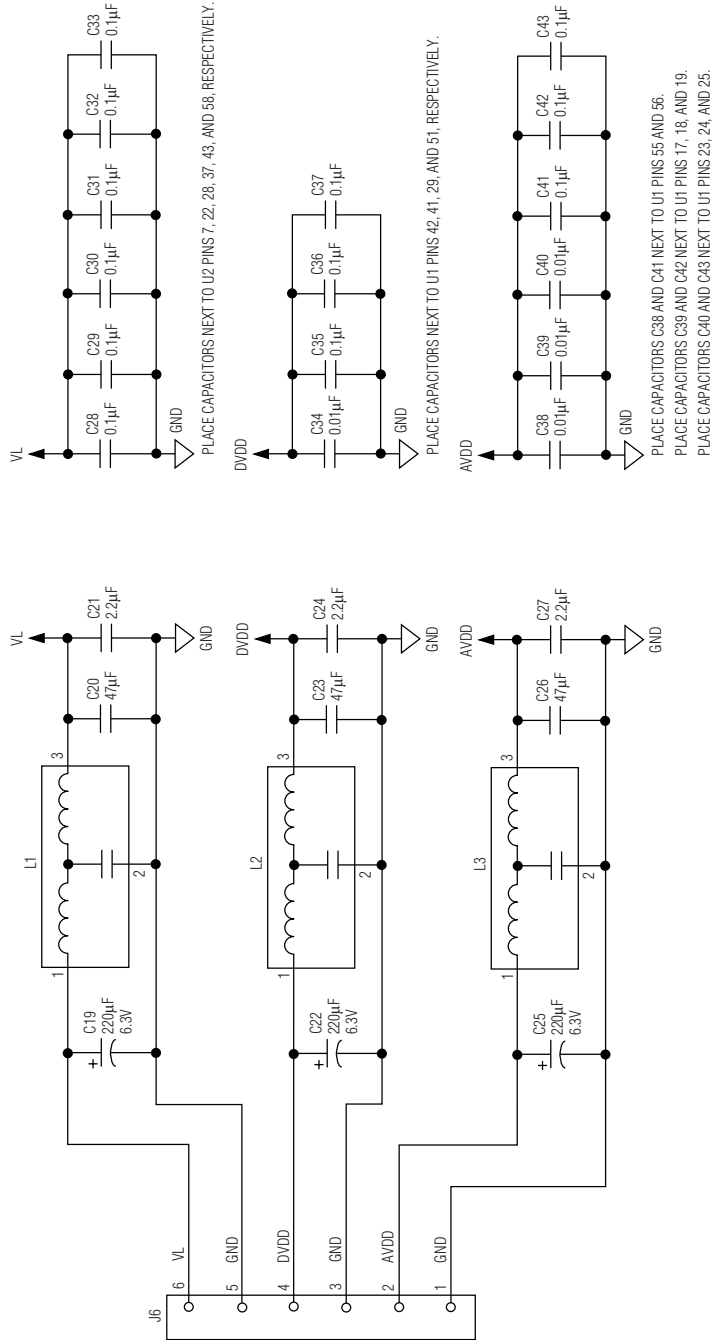

Figure 2b. MAX19586/MAX19588 EV Kits Schematic (Sheet 2 of 2)

# MAX19586/MAX19588 Evaluation Kits

**Evaluate: MAX19586/MAX19588**

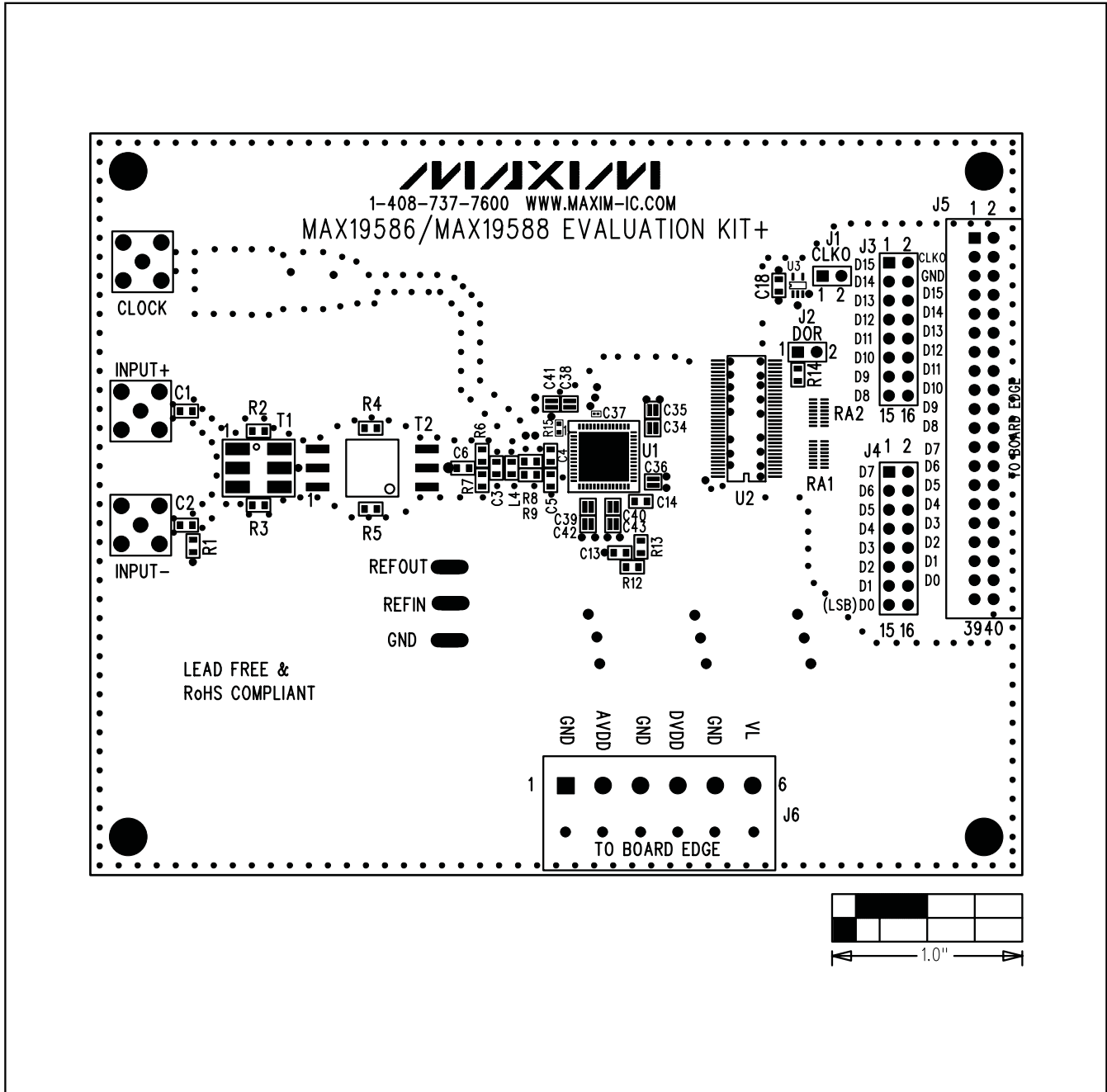

Figure 3. MAX19586/MAX19588 EV Kits Component Placement Guide—Component Side



# MAX19586/MAX19588 Evaluation Kits

Evaluate: MAX19586/MAX19588

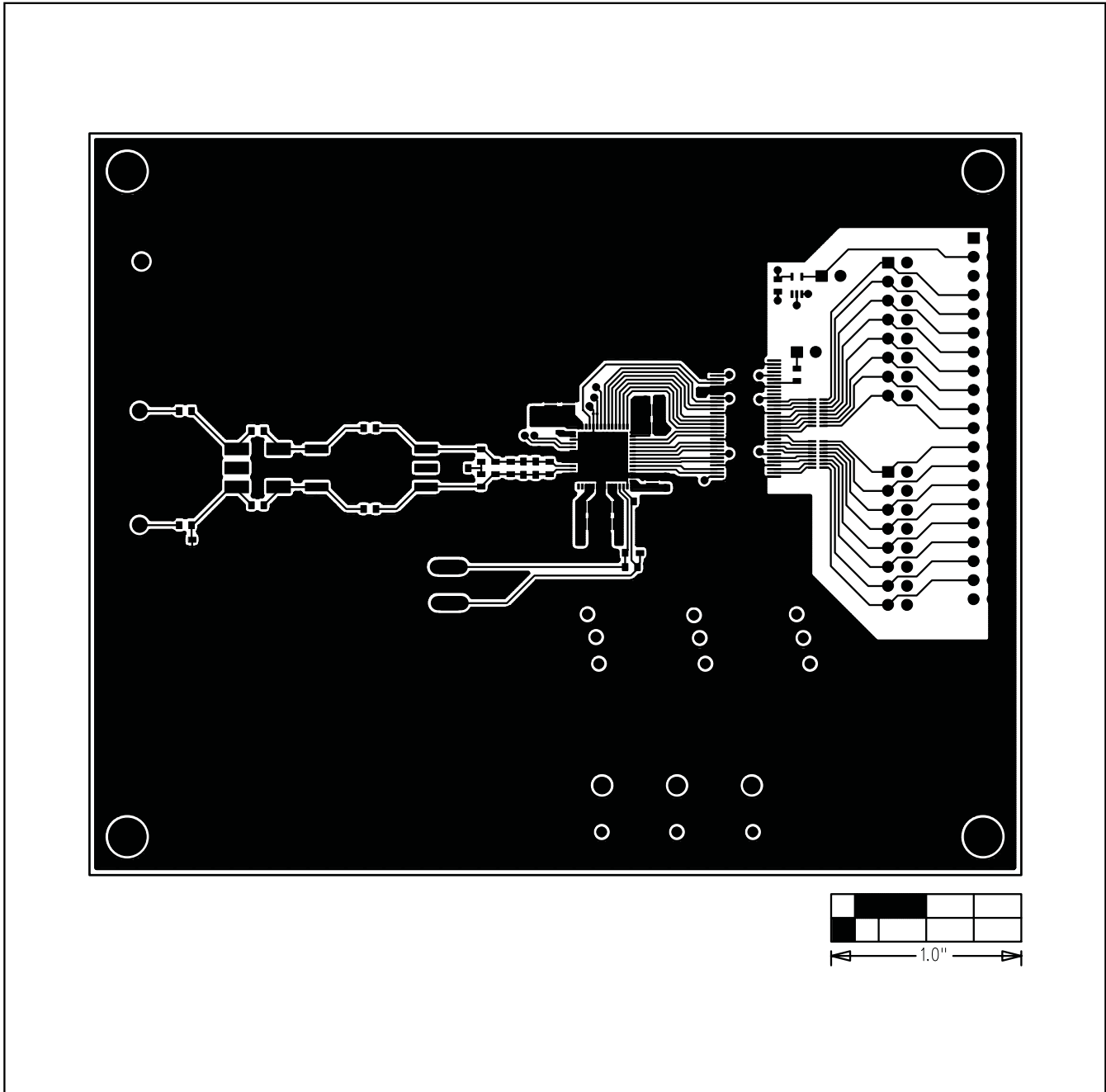

Figure 4. MAX19586/MAX19588 EV Kits PCB Layout—Component Side

# MAX19586/MAX19588 Evaluation Kits

Evaluate: MAX19586/MAX19588

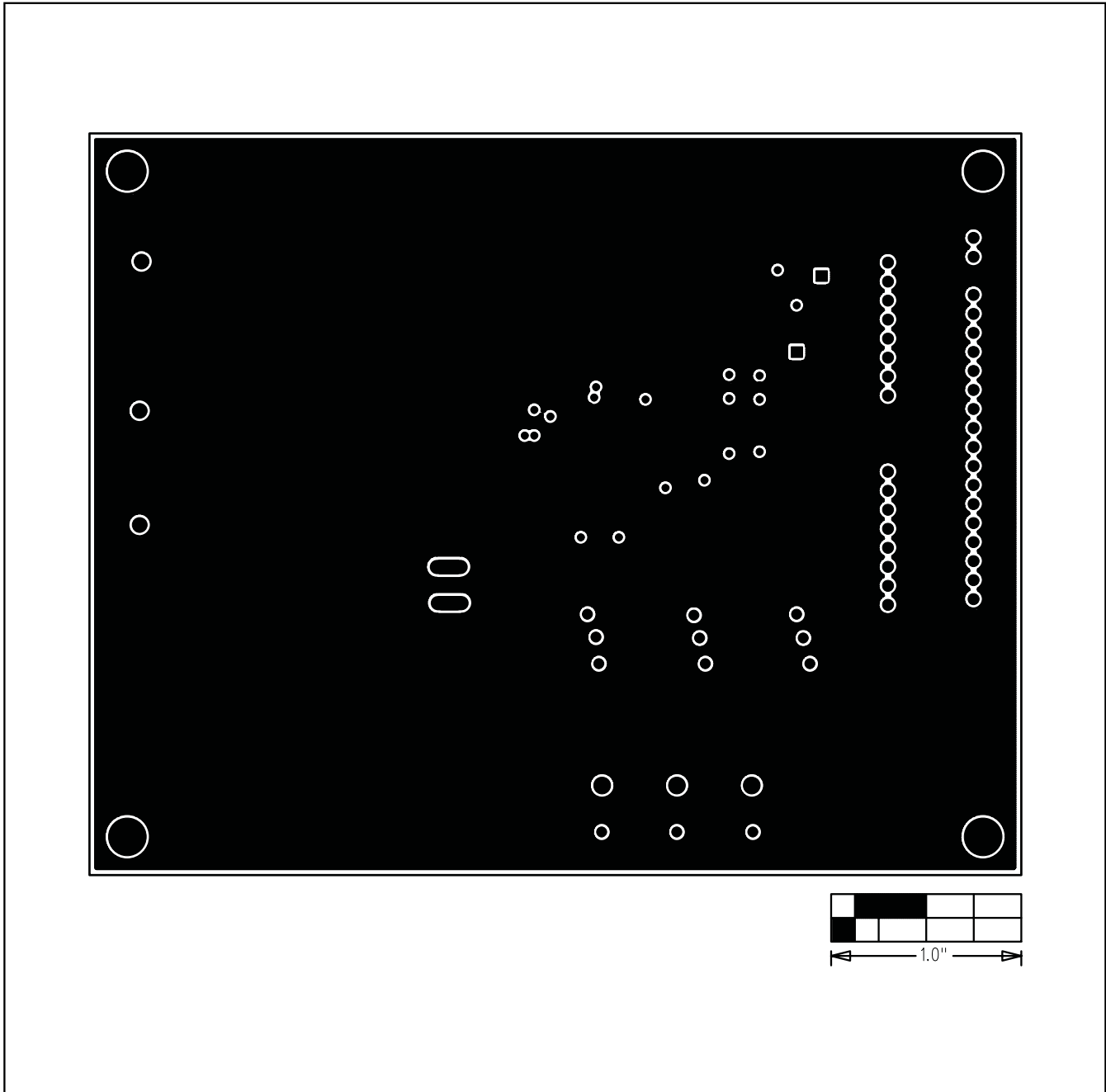

Figure 5. MAX19586/MAX19588 EV Kits PCB—GND Layer 2

# MAX19586/MAX19588 Evaluation Kits

Evaluate: MAX19586/MAX19588

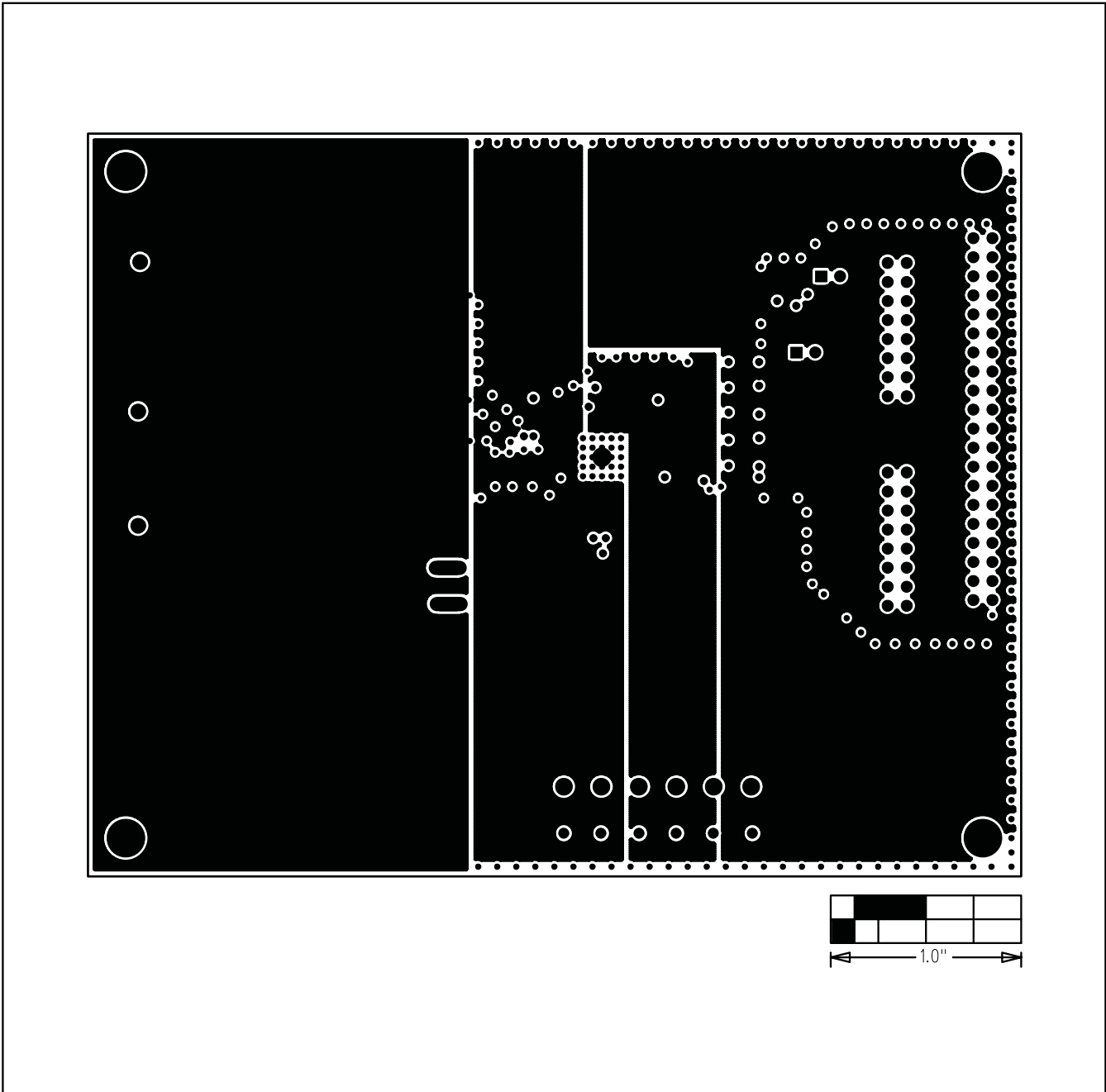

Figure 6. MAX19586/MAX19588 EV Kits PCB—VDD Layer 3

# MAX19586/MAX19588 Evaluation Kits

Evaluate: MAX19586/MAX19588

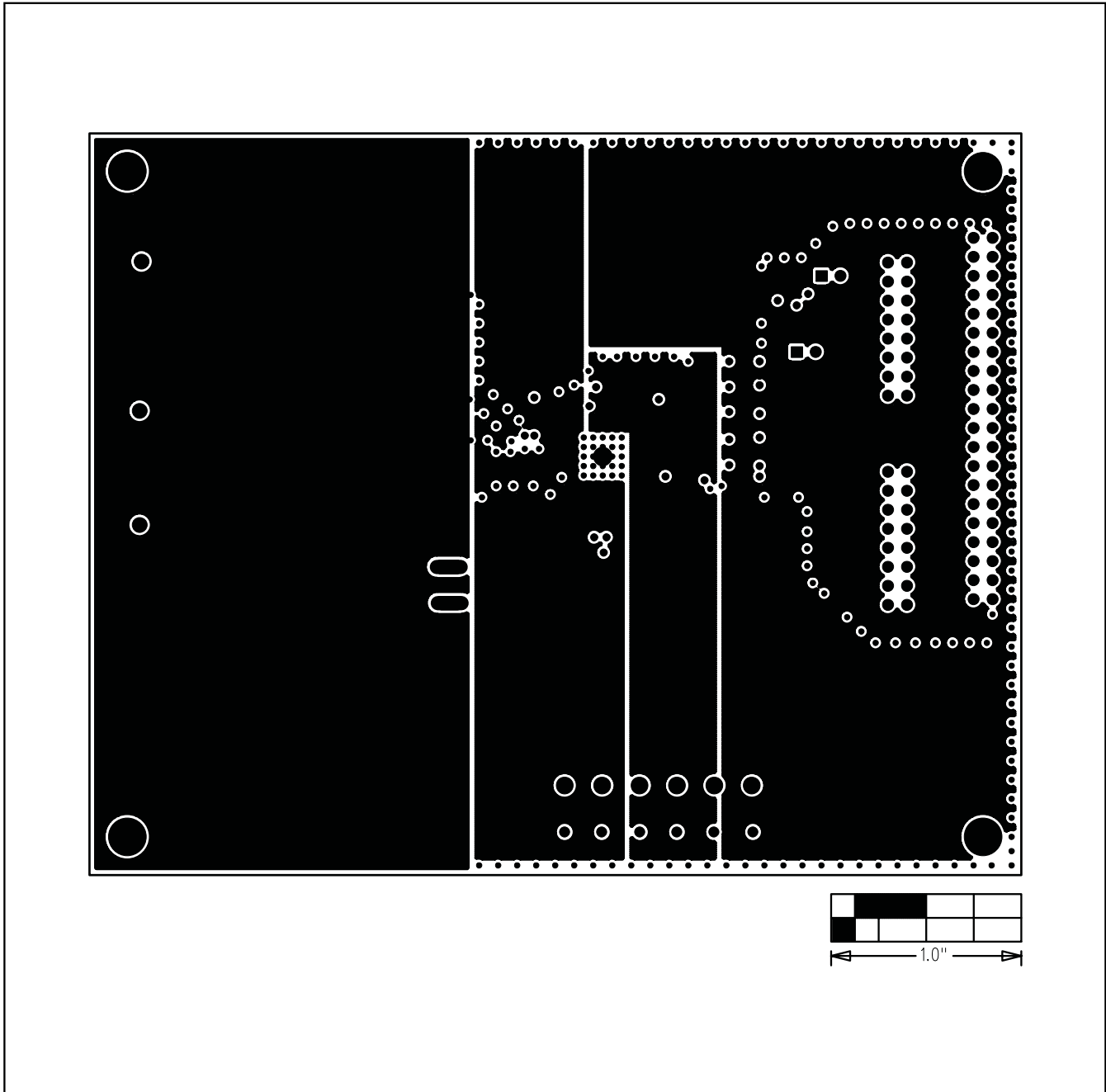

Figure 7. MAX19586/MAX19588 EV Kits PCB—VDD Layer 4

# MAX19586/MAX19588 Evaluation Kits

Evaluate: MAX19586/MAX19588

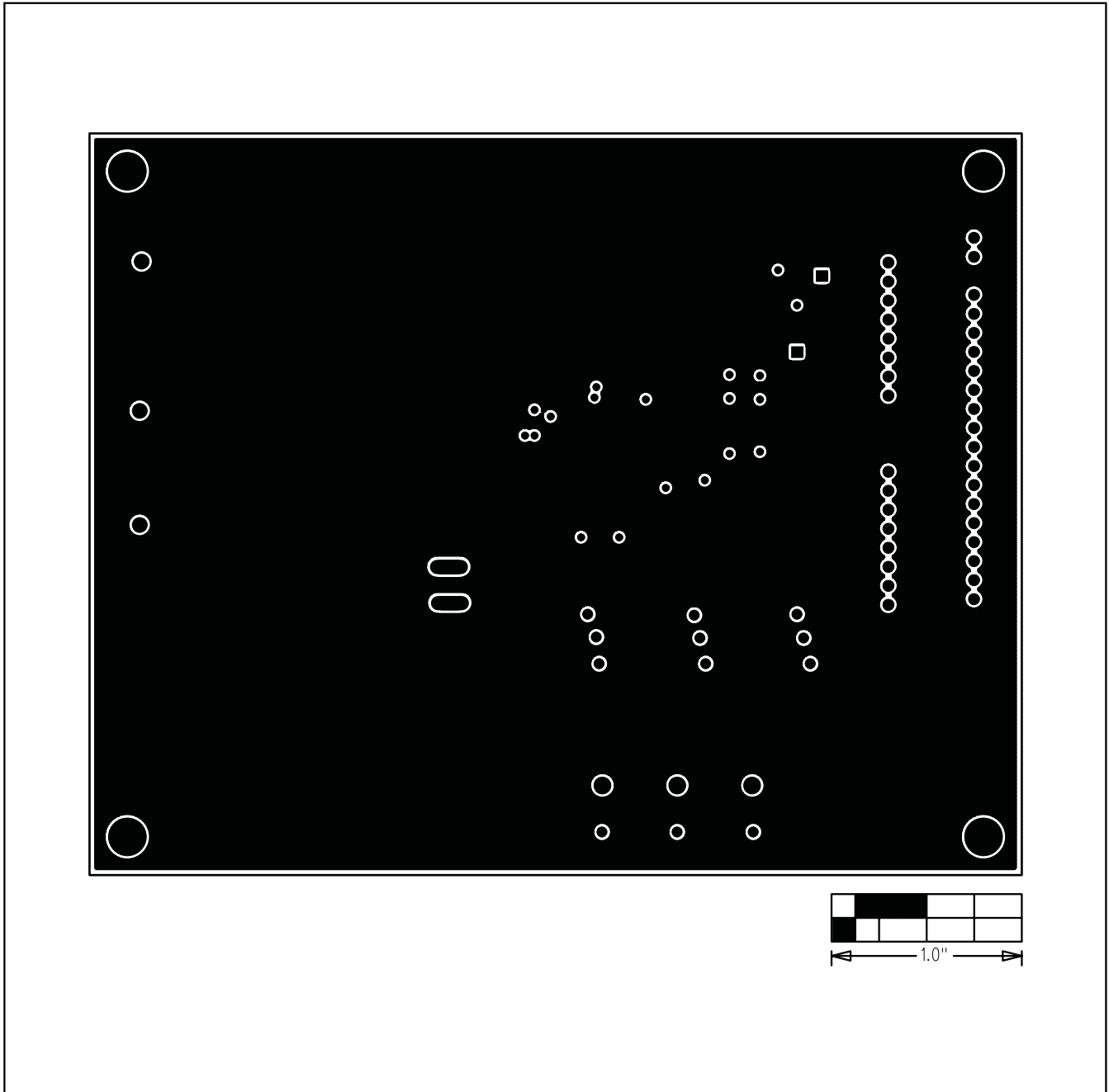

Figure 8. MAX19586/MAX19588 EV Kits PCB—GND Layer 5

# MAX19586/MAX19588 Evaluation Kits

**Evaluate: MAX19586/MAX19588**

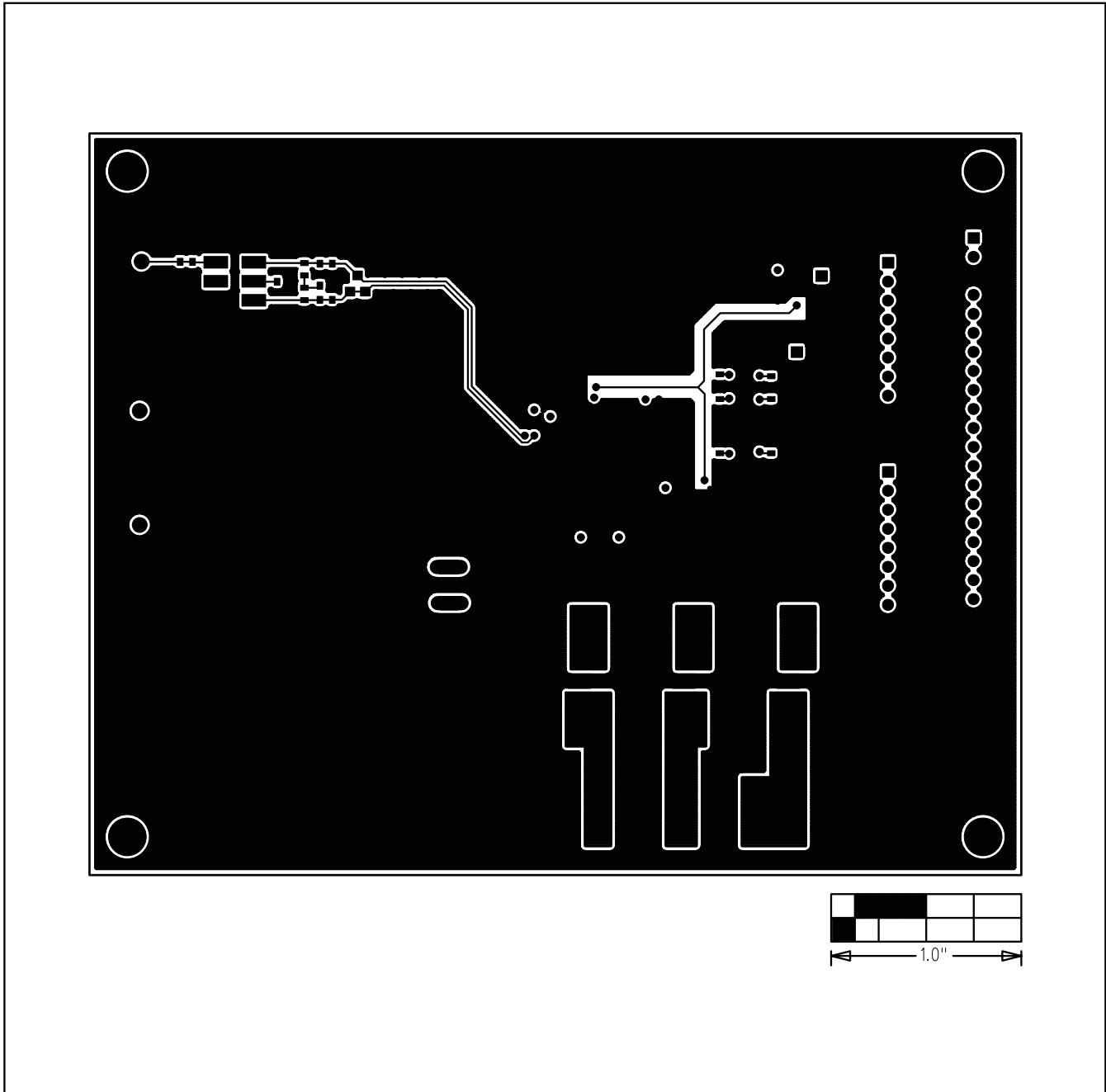

Figure 9. MAX19586/MAX19588 EV Kits PCB—Solder Side

# MAX19586/MAX19588 Evaluation Kits

Evaluate: MAX19586/MAX19588

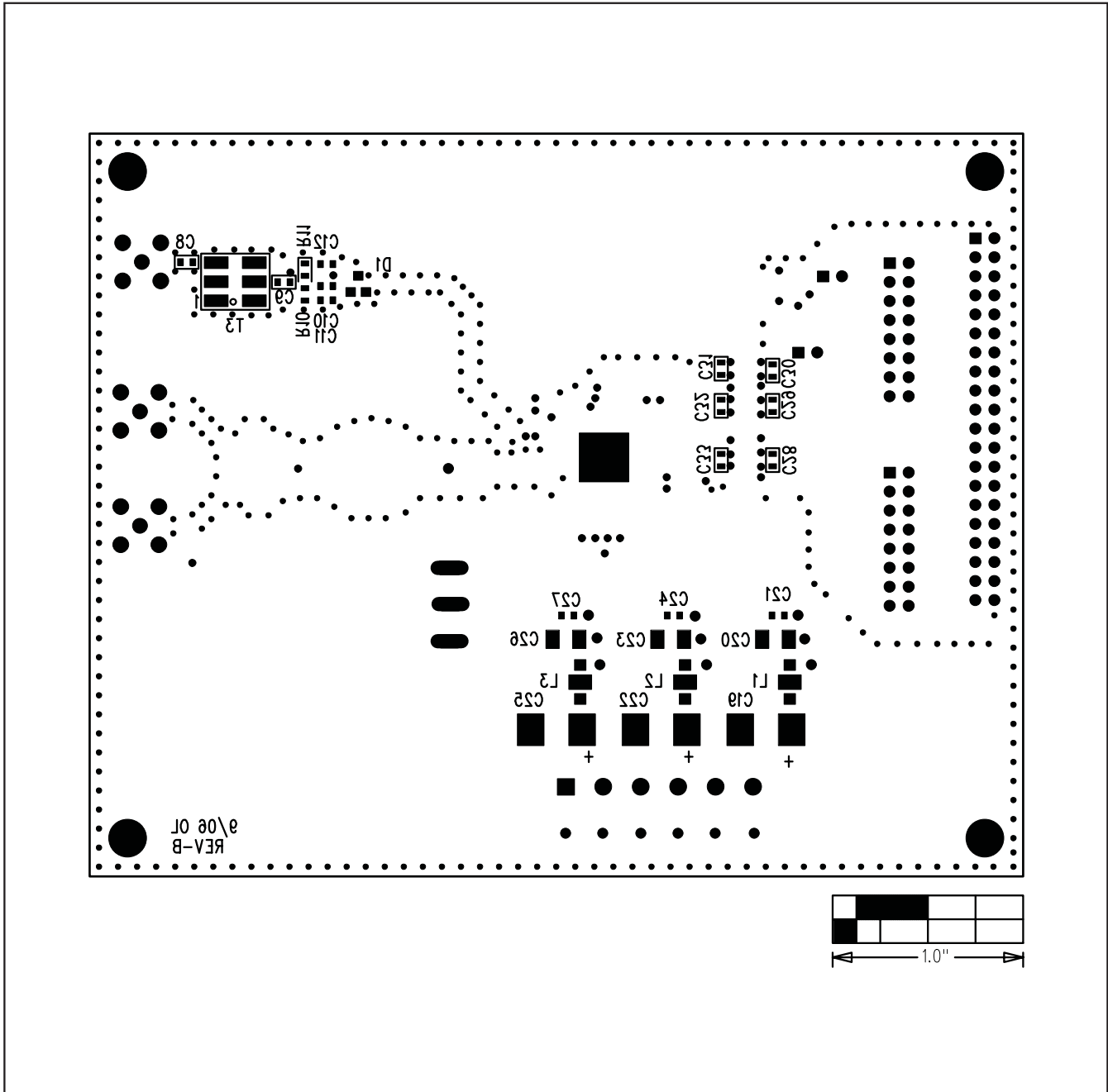

Figure 10. MAX19586/MAX19588 EV Kits Component Placement Guide—Solder Side

## Revision History

Pages changed at Rev 1: 1–14

Maxim cannot assume responsibility for use of any circuitry other than circuitry entirely embodied in a Maxim product. No circuit patent licenses are implied. Maxim reserves the right to change the circuitry and specifications without notice at any time.

Maxim Integrated Products, 120 San Gabriel Drive, Sunnyvale, CA 94086 408-737-7600 15



## Стандарт Электрон Связь

Мы молодая и активно развивающаяся компания в области поставок электронных компонентов. Мы поставляем электронные компоненты отечественного и импортного производства напрямую от производителей и с крупнейших складов мира.

Благодаря сотрудничеству с мировыми поставщиками мы осуществляем комплексные и плановые поставки широчайшего спектра электронных компонентов.

Собственная эффективная логистика и склад в обеспечивает надежную поставку продукции в точно указанные сроки по всей России.

Мы осуществляем техническую поддержку нашим клиентам и предпродажную проверку качества продукции. На все поставляемые продукты мы предоставляем гарантию .

Осуществляем поставки продукции под контролем ВП МО РФ на предприятия военно-промышленного комплекса России , а также работаем в рамках 275 ФЗ с открытием отдельных счетов в уполномоченном банке. Система менеджмента качества компании соответствует требованиям ГОСТ ISO 9001.

Минимальные сроки поставки, гибкие цены, неограниченный ассортимент и индивидуальный подход к клиентам являются основой для выстраивания долгосрочного и эффективного сотрудничества с предприятиями радиоэлектронной промышленности, предприятиями ВПК и научно-исследовательскими институтами России.

С нами вы становитесь еще успешнее!

### Наши контакты:

**Телефон:** +7 812 627 14 35

**Электронная почта:** [sales@st-electron.ru](mailto:sales@st-electron.ru)

**Адрес:** 198099, Санкт-Петербург,  
Промышленная ул, дом № 19, литера Н,  
помещение 100-Н Офис 331