

IRAUDAMP10

300W x 2 Channel Class D Audio Power Amplifier Using the IRS2052M and IRF6775

By

Jun Honda, Yasushi Nishimura and Liwei Zheng

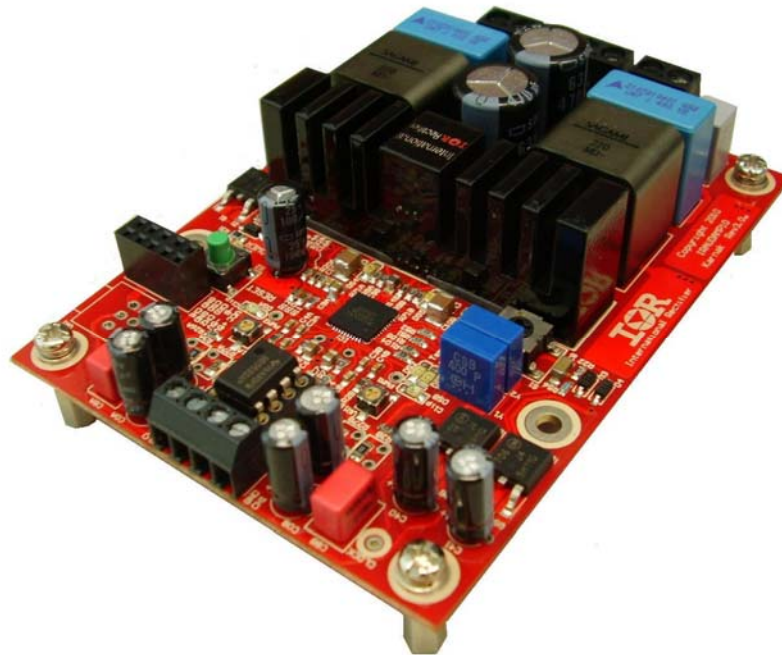

CAUTION:

International Rectifier suggests the following guidelines for safe operation and handling of IRAUDAMP10 Demo board;

- Always wear safety glasses whenever operating Demo Board
- Avoid personal contact with exposed metal surfaces when operating Demo Board
- Turn off Demo Board when placing or removing measurement probes

| TABLE OF CONTENTS | PAGE |
|--|-------------|
| INTRODUCTION | 3 |
| SPECIFICATIONS | 3 |
| CONNECTION SETUP | 5 |
| CONNECTOR DESCRIPTION | 5 |
| TEST PROCEDURES | 6 |
| PERFORMANCE AND TEST GRAPHS | 7 |
| SOFT CLIPPING | 10 |
| EFFICIENCY | 11 |
| THERMAL CONSIDERATIONS | 11 |
| THERMAL INTERFACE MATERIAL'S PRESSURE CONTROL..... | 12 |
| POWER SUPPLY REJECTION RATIO (PSRR) | 14 |
| SHORT CIRCUIT PROTECTION RESPONSE | 15 |
| IRAUDAMP10 OVERVIEW | 16 |
| FUNCTIONAL DESCRIPTIONS | 18 |
| IRS2052M GATE DRIVER IC..... | 18 |
| SELF-OSCILLATING FREQUENCY..... | 19 |
| ADJUSTMENTS OF SELF-OSCILLATING FREQUENCY..... | 19 |
| INTERNAL CLOCK OSCILLATOR..... | 19 |
| SELECTABLE DEAD-TIME..... | 20 |
| PROTECTION SYSTEM OVERVIEW | 21 |
| CLICK AND POP NOISE REDUCTION | 23 |
| BUS PUMPING | 24 |
| INPUT SIGNAL AND GAIN SETTING | 24 |
| GAIN SETTING | 25 |
| IRAUDAMP10 FABRICATION MATERIALS | 27 |
| IRAUDAMP10 PCB SPECIFICATIONS | 31 |
| REVISION CHANGES DESCRIPTIONS | 34 |

Introduction

The IRAUDAMP10 Demo board is a reference design which uses only one IC (IRS2052M) to derive appropriate input signals, amplify the audio input, and achieve a two-channel 280 W/ch (4Ω, THD+N=1%) half-bridge Class D audio power amplifier. The reference design demonstrates how to use the IRS2052M Class D audio controller and gate driver IC, implement protection circuits, and design an optimum PCB layout using IRF6775 DirectFET MOSFETs. The reference design contains all the required housekeeping power supplies for ease of use. The two-channel design is scalable, for power and number of channels.

Applications

- AV receivers
- Home theater systems
- Mini component stereos
- Powered speakers
- Sub-woofers
- Musical Instrument amplifiers
- Automotive after market amplifiers

Features

| | |
|-------------------------------|--|
| Output Power: | 300W x 2 channels (4Ω, THD+N=1%) or 370W x 2 channels (4Ω, THD+N=10%) |
| Residual Noise: | 220μV, IHF-A weighted, AES-17 filter |
| Distortion: | 0.008% THD+N @ 100W, 4Ω |
| Efficiency: | 90% @ 300W, 4Ω, single-channel driven, Class D stage |
| Multiple Protection Features: | Over-current protection (OCP), high side and low side Over-voltage protection (OVP), Under-voltage protection (UVP), high side and low side Over-temperature protection (OTP) |
| PWM Modulator: | Self-oscillating half-bridge topology with optional clock synchronization |

Specifications

| General Test Conditions (unless otherwise noted) | | Notes / Conditions |
|--|---|--------------------------------|
| Supply Voltages | ±50V | |
| Load Impedance | 4Ω | |
| Self-Oscillating Frequency | 500kHz | No input signal, Adjustable |
| Gain Setting | 30.8dB | 1Vrms input yields rated power |
| Electrical Data | | Notes / Conditions |
| IR Devices Used | IRS2052M Audio Controller and Gate-Driver, IRF6775 DirectFET MOSFETs | |
| Modulator | Self-oscillating, second order sigma-delta modulation, analog input | |
| Power Supply Range | ± 25V to ±50V | Bipolar power supply |
| Output Power CH1-2: (1% THD+N) | 300W | 1kHz, ±50V |
| Output Power CH1-2: (10% THD+N) | 370W | 1kHz, ±50V |

| | | |
|------------------------------|-----------|---|
| Rated Load Impedance | 8-4Ω | Resistive load |
| Standby Supply Current | +45/-95mA | No input signal |
| Total Idle Power Consumption | 7W | No input signal |
| Channel Efficiency | 90% | Single-channel driven, 300W, Class D stage |

Audio Performance

| | Class D Output | Notes / Conditions |
|-----------------------------------|-----------------------|--|
| THD+N, 1W | 0.015% | |
| THD+N, 20W | 0.009% | 1kHz, Single-channel driven |
| THD+N, 100W | 0.008% | |
| THD+N, 200W | 0.015% | |
| Dynamic Range | 100dB | A-weighted, AES-17 filter, Single-channel operation |
| Residual Noise, 22Hz - 20kHzAES17 | 220μV | Self-oscillating – 500kHz |
| Damping Factor | 51 | 1kHz, relative to 4Ω load |
| Channel Separation | 74dB | 100Hz |
| | 74dB | 1kHz |
| | 70dB | 10kHz |
| Frequency Response : 20Hz-20kHz | ±1dB | 1W, 4Ω - 8Ω Load |
| : 20Hz-35kHz | ±3dB | |

Physical Specifications

| | |
|------------|---|
| Dimensions | 3.94"(L) x 2.83"(W) x 0.85"(H) 100 mm (L) x 72 mm (W) x 21.5 mm(H) |
| Weight | 0.130kgm |

Connection Setup

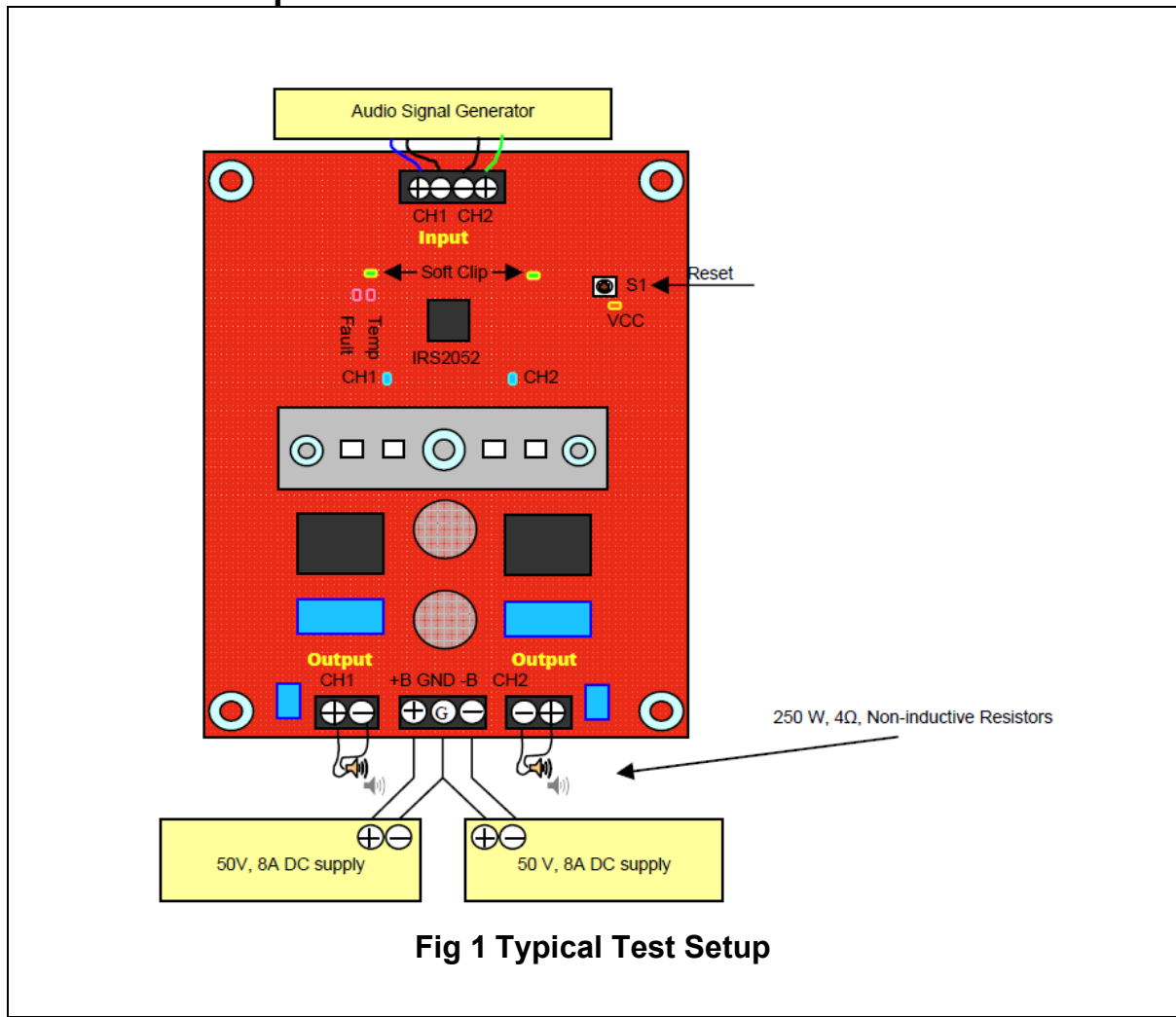

Fig 1 Typical Test Setup

Connector Description

| | Pin # | Pin Name | Pin Description |
|-----|-------|------------|-------------------------------------|
| CN1 | 1 | CH1 INPUT | Analog input for CH1 |
| | 2 | GND | Floating ground of Channel 1 input |
| | 3 | GND | Floating ground of Channel 2 input |
| | 4 | CH2 INPUT | Analog input for CH2 |
| P1 | 1 | -B | -50V supply referenced to GND. |
| | 2 | GND | Ground signal from MB. |
| | 3 | +B | +50V supply referenced to GND. |
| P2 | 1 | CH2 OUTPUT | Output of Channel 2 |
| | 2 | GND | Floating ground of Channel 2 output |
| P3 | 1 | GND | Floating ground of Channel 1 output |
| | 2 | CH1 OUTPUT | Output of Channel 1 |

Test Procedures

Test Setup:

1. Connect 4 Ω -200 W dummy loads to 2 output connectors (P2 and P3 as shown on Fig 1) and an Audio Precision analyzer (AP).
2. Connect the Audio Signal Generator to CN1 for CH1~CH2 respectively (AP).
3. Set up the dual power supply with voltages of $\pm 50V$; current limit to 5A.
4. TURN OFF the dual power supply before connecting to On of the unit under test (UUT).
5. Connect the dual power supply to P1. as shown on Fig 1

Power up:

6. Turn ON the dual power supply. The $\pm B$ supplies must be applied and removed at the same time.
7. One orange and two blue LED should turn ON immediately and stay ON
8. Quiescent current for the positive supply should be 45mA \pm 10mA at +50V.
9. Quiescent current for the negative supply should be 95mA \pm 10mA at -50V.

Switching Frequency test

10. With an Oscilloscope, monitor the switching waveform at test points VS1~VS2. Adjust VR1A and VR1B to set the self oscillating frequency to 500 kHz \pm 25 kHz when DUT in free oscillating mode.

Functionality Audio Tests:

11. Set the signal generator to 1kHz, 20 mV_{RMS} output.
12. Connect the audio signal generator to CN1(Input of CH1,CH2,CH3)
13. Sweep the audio signal voltage from 15 mV_{RMS} to 1 V_{RMS}.
14. Monitor the output signals at P2/P3 with an oscilloscope. The waveform must be a non distorted sinusoidal signal.
15. Observe that a 1 V_{RMS} input generates an output voltage of 34.88 V_{RMS}(CH1/CH2). The ratio, R4x/(R3x) and R30x/(R31x), determines the voltage gain of IRAUDAMP10.

Test Setup using Audio Precision (Ap):

16. Use an unbalanced-floating signal from the generator outputs.
17. Use balanced inputs taken across output terminals, P2 and P3.
18. Connect Ap frame ground to GND at terminal P1.
19. Select the AES-17 filter(pull-down menu) for all the testing except frequency response.
20. Use a signal voltage sweep range from 15 mV_{RMS} to 1.5 V_{RMS}.
21. Run Ap test programs for all subsequent tests as shown in Fig 2- Fig 7below.

Performance and test graphs

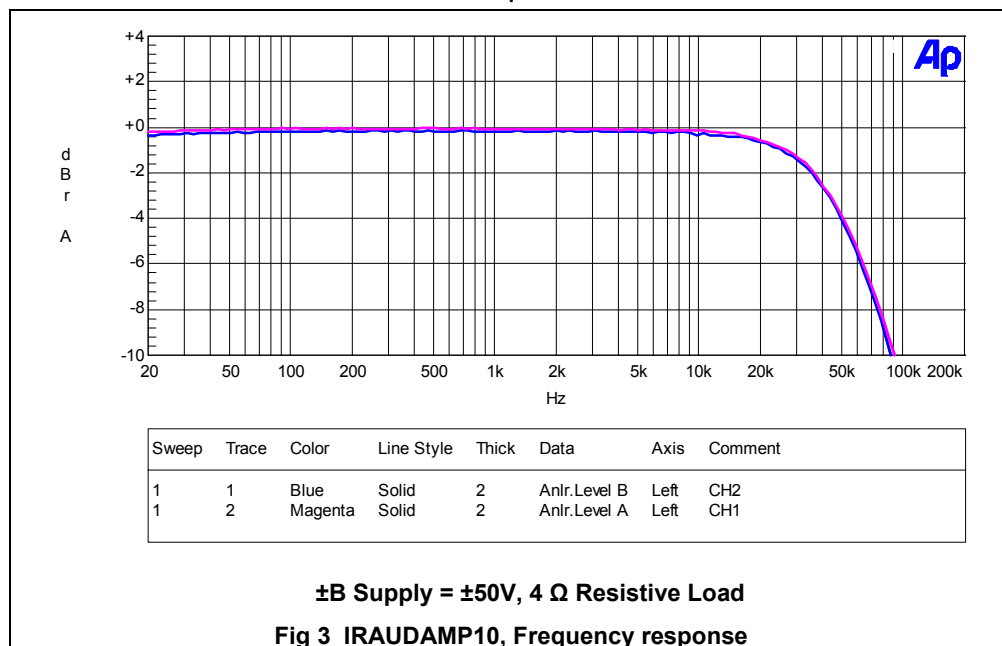
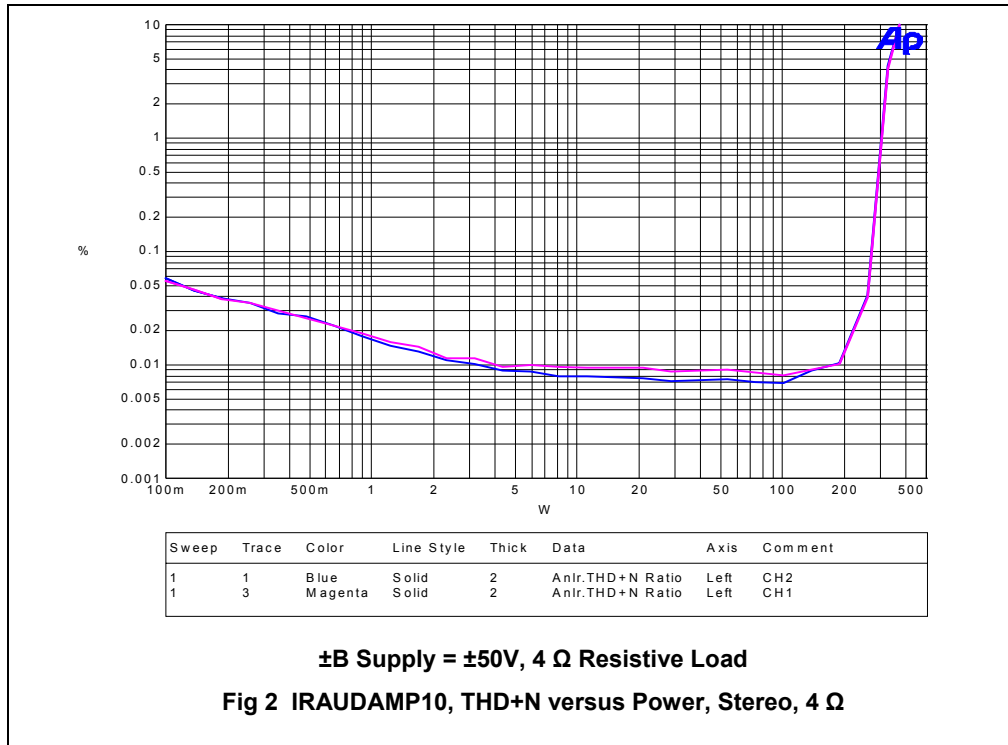

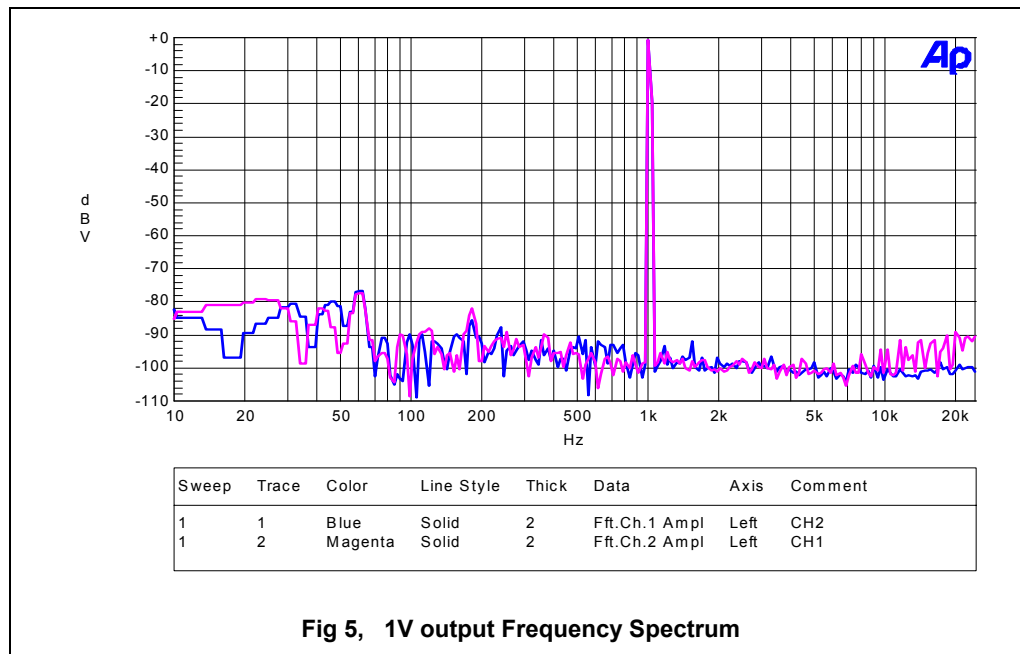
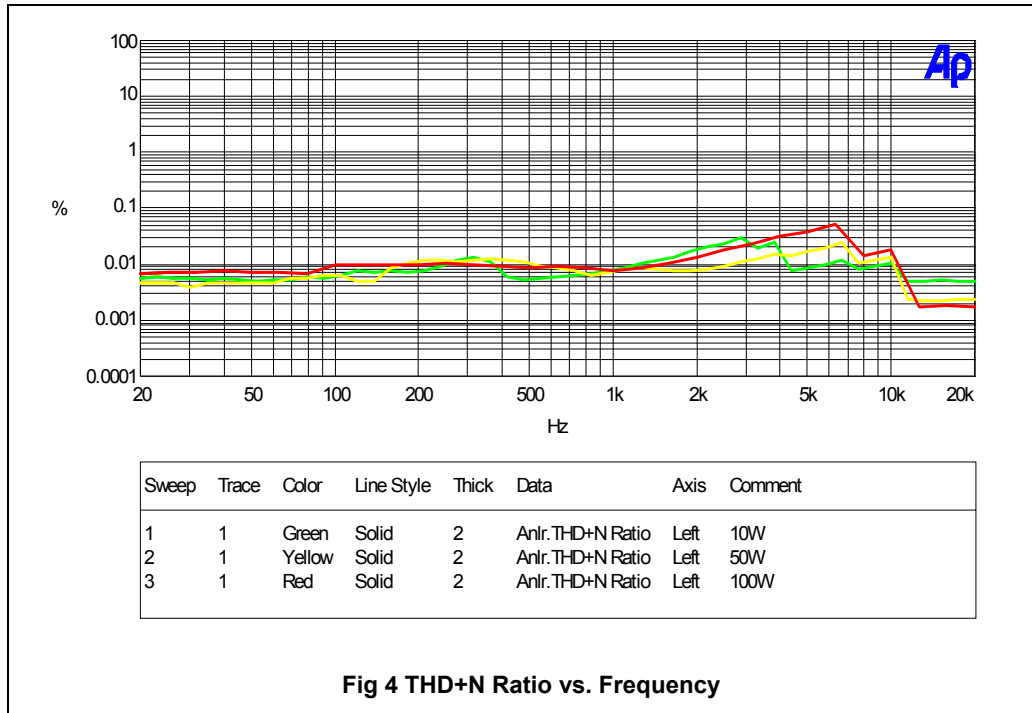

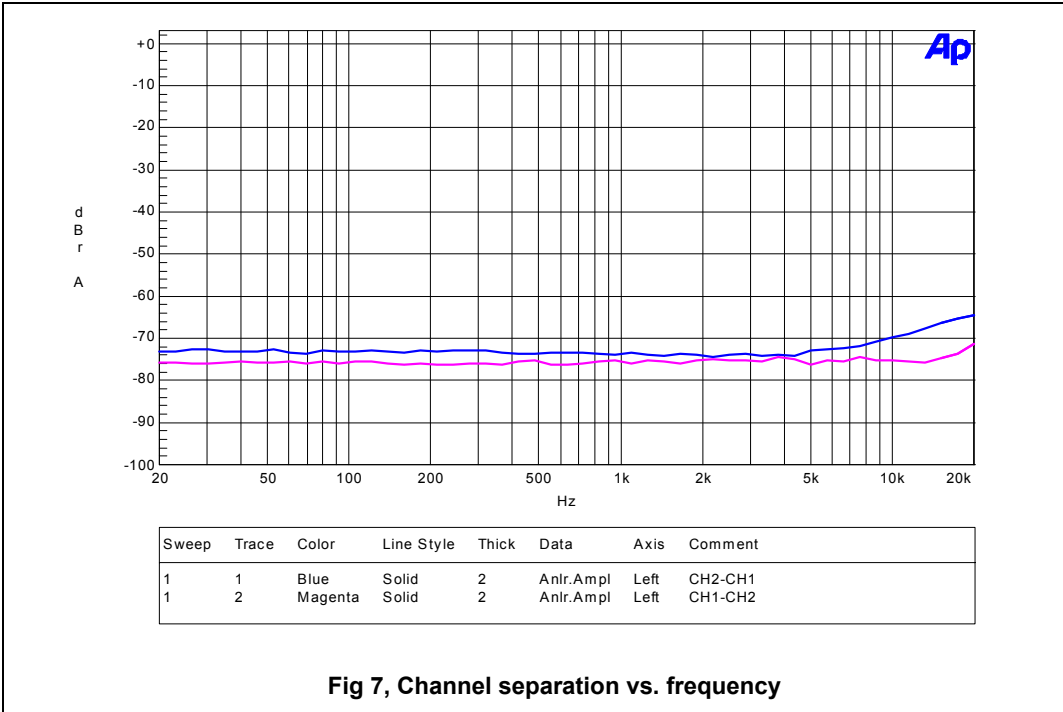
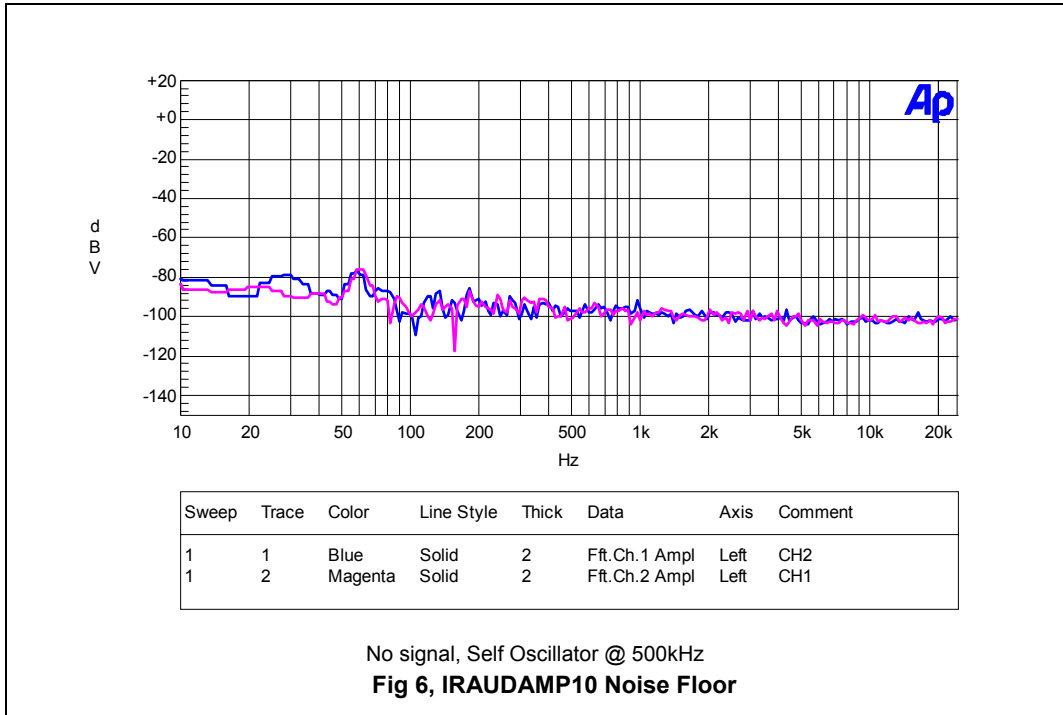

Soft Clipping

IRS2052M has Clipping detection function, it monitors error voltage in COMP pin with a window comparator and pull an open drain nmos referenced to GND. Threshold to detect is at 10% and 90% of VAA-VSS. Each channel has independent CLIP outputs. Once IRS2052M detects Clipping, the CLIP pin can generate pulses to trigger soft clipping circuit, which can limit output's maximum power as Fig 9(soft clipping circuit is not available on AMP10 reference board).

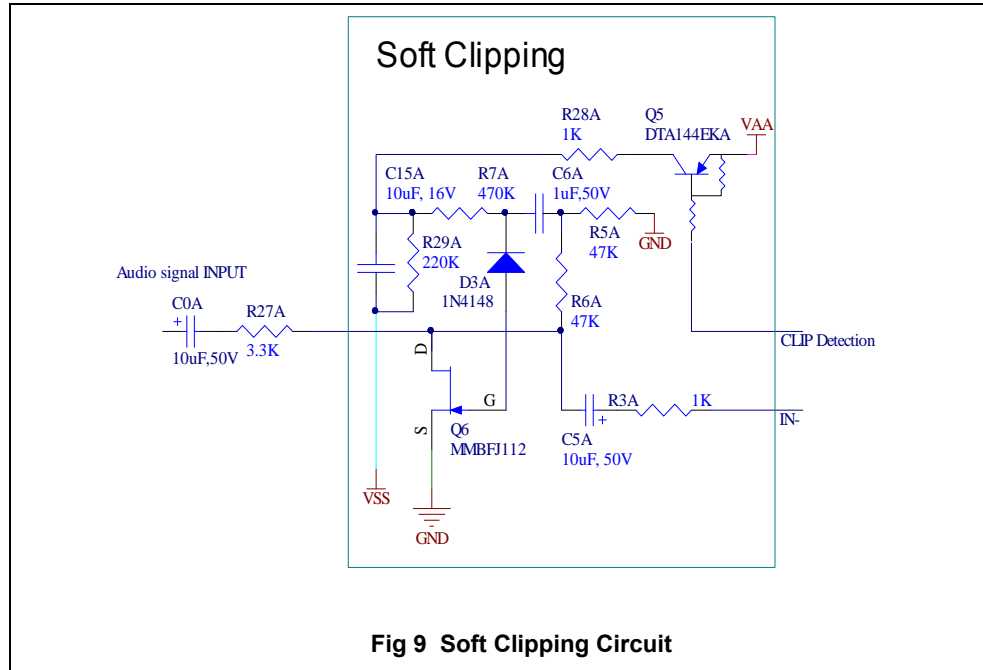

Efficiency

Fig 10 shows efficiency characteristics of the IRAUDAMP10. The high efficiency is achieved by following major factors:

- 1) Low conduction loss due to the DirectFETs offering low $R_{DS(ON)}$
- 2) Low switching loss due to the DirectFETs offering low input capacitance for fast rise and fall times

Secure dead-time provided by the IRS2052M, avoiding cross-conduction.

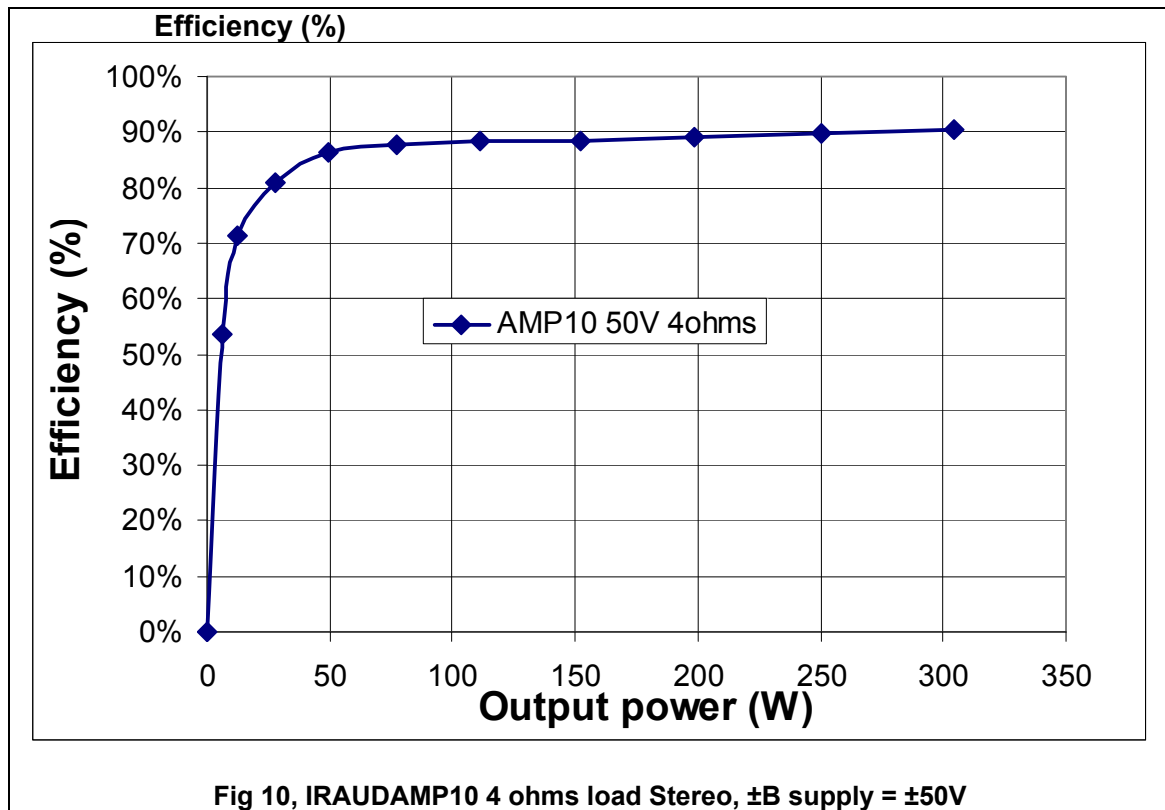

Thermal Considerations

With this high efficiency, the IRAUDAMP10 design can handle one-eighth of the continuous rated power, which is generally considered to be a normal operating condition for safety standards, without additional heatsinks or forced air-cooling.

Thermal Interface Material's Pressure Control

The pressure between DirectFET & TIM (Thermal Interface Material) is controlled by depth of Heat Spreader's groove. Choose TIM which is recommended by [IR](#). (Refer to AN-1035 for more details). TIM's manufacturer thickness, conductivity, & etc. determine pressure requirement. Below shows selection options recommended:

Common Thermal Interface Materials Cost Trades

| Mfr. | Material | Type | Thickness (mils) | Pressure Required | Dispense/Apply | Clips/Screws | Can be applied to heat sink? | Mechanical Placement? |
|------------------|----------------|----------------------------------|------------------|-------------------|----------------|--------------|------------------------------|-----------------------|
| Dow Corning | 1-4173 | 1 part heat-cured adhesive | # | Yes | Dispense | Clips | N | Y |
| Dow Corning | SE 4451 | 2 part heat-cured adhesive | # | Yes | Dispense | Clips | N | Y |
| Dow Corning | 3-6652 | 2 part heat-cured adhesive | # | Yes | Dispense | Clips | N | Y |
| Dow Corning | TP-1500 Pad | Tacky - Phase Change at 52°C | 10 | >5psi, 20psi typ | Apply | Clips | Y | Y |
| Bergquist | Gap Pad 3000 | conformable filled polymer sheet | 15 | >10psi | Apply | Clips/Screws | N | Y |
| Bergquist | Gap Pad 2000 | conformable filled polymer sheet | 10 | >10psi | Apply | Clips/Screws | N | Y |
| Bergquist | Hi Flow 300 | Phase Change at 55°C | 2.4 | >10psi | Apply | Clips | Y | * |
| Bergquist | Hi Flow 625 | Phase Change at 65°C | 5 | >10psi | Apply | Clips | Y | * |
| Bergquist | Hi Flow 818 | Phase Change at 65°C | 5.5 | >10psi | Apply | Clips | Y | * |
| Bergquist | Sil Pad 800 | Conformable silicone elastomer | 5 | >10 higher better | Apply | Clips/Screws | Y | * |
| Bergquist | Sil Pad 900 | Conformable silicone elastomer | 9 | >10 higher better | Apply | Clips/Screws | Y | * |
| Bergquist | Sil Pad A1500 | Conformable silicone elastomer | 10 | 10-50psi | Apply | Clips/Screws | Y | * |
| Bergquist | Sil Pad A2000 | Conformable silicone elastomer | 10 | 10-50psi | Apply | Clips/Screws | Y | * |
| Bergquist | Bond Ply 100 | Pressure sensitive adhesive tape | 5 | >10psi | Apply | Clips | Y | Y |
| Bergquist | Bond Ply 100 | Pressure sensitive adhesive tape | 11 | >10psi | Apply | Clips | Y | Y |
| Thermoset (Lord) | Gelease MG-120 | Thermal grease/gel | # | 5-7lbf | Dispense | Clips | N | Y |
| Shin Etsu | X-23-7783D | Thermal grease | # | - | Dispense | Clips | N | Y |
| Shin Etsu | X-23-7762 | Thermal grease | # | - | Dispense | Clips | N | Y |

Fig 11 TIM Information

Check the TIM's compression deflection with constant rate of strain (example as Fig.12) base on manufacturer's datasheet. According to the stress requirement, find strain range for the TIM. Then, calculate heat spreader groove depth as below:

$$\text{Groove Depth} = \text{DirectFET's Height} + \text{TIM's Thickness} * \text{strain}$$

**DirectFET's height should be measured from PCB to the top of DirectFET after reflow. The average height of IRF6775 is 0.6mm.

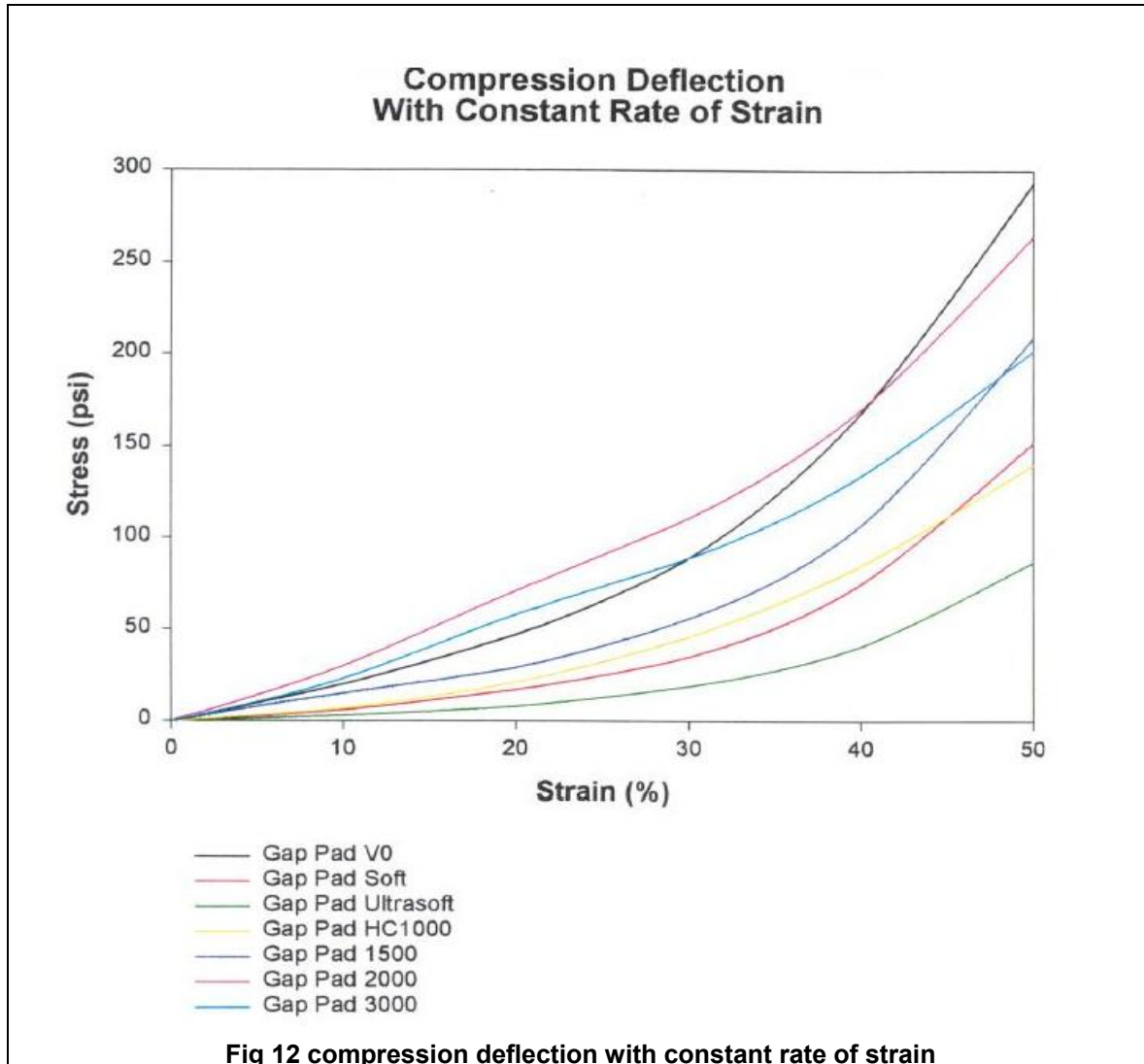

Power Supply Rejection Ratio (PSRR)

The IRAUDAMP10 obtains good power supply rejection ratio of -60 dB at 1kHz shown in Fig 13. With this high PSRR, IRAUDAMP10 accepts any power supply topology when the supply voltages fit between the min and max range.

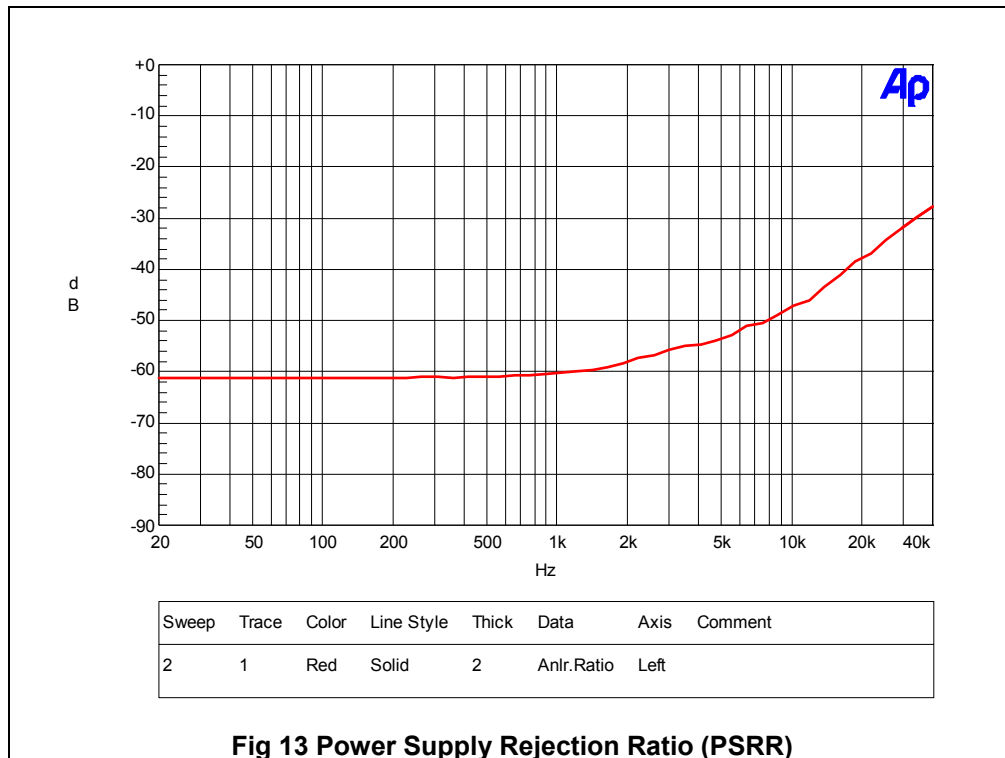

Short Circuit Protection Response

Figs 14-15 show over current protection reaction time of the IRAUDAMP10 in a short circuit event. As soon as the IRS2052M detects an over current condition, it shuts down PWM. After one second, the IRS2052M tries to resume the PWM. If the short circuit persists, the IRS2052M repeats try and fail sequences until the short circuit is removed.

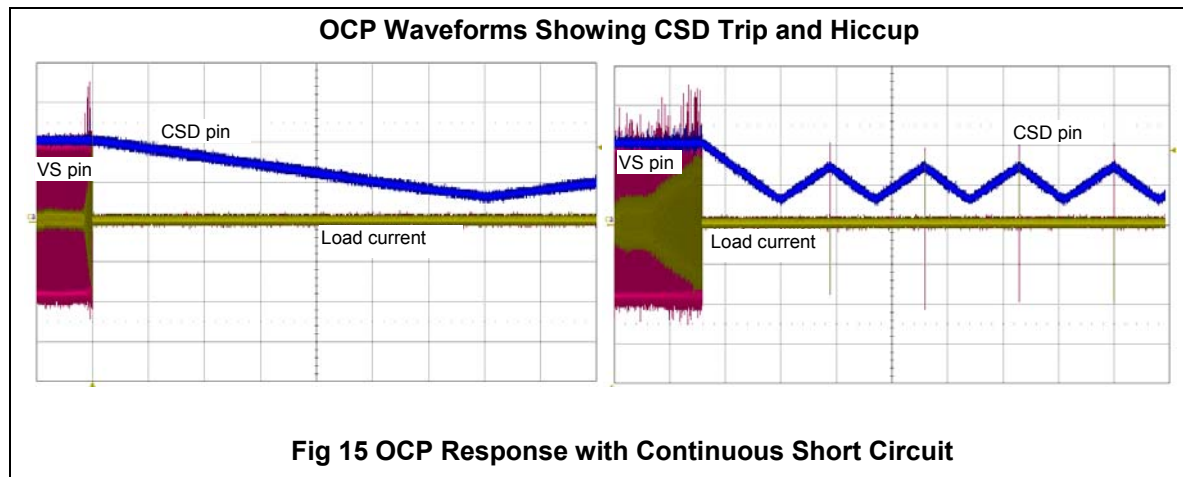
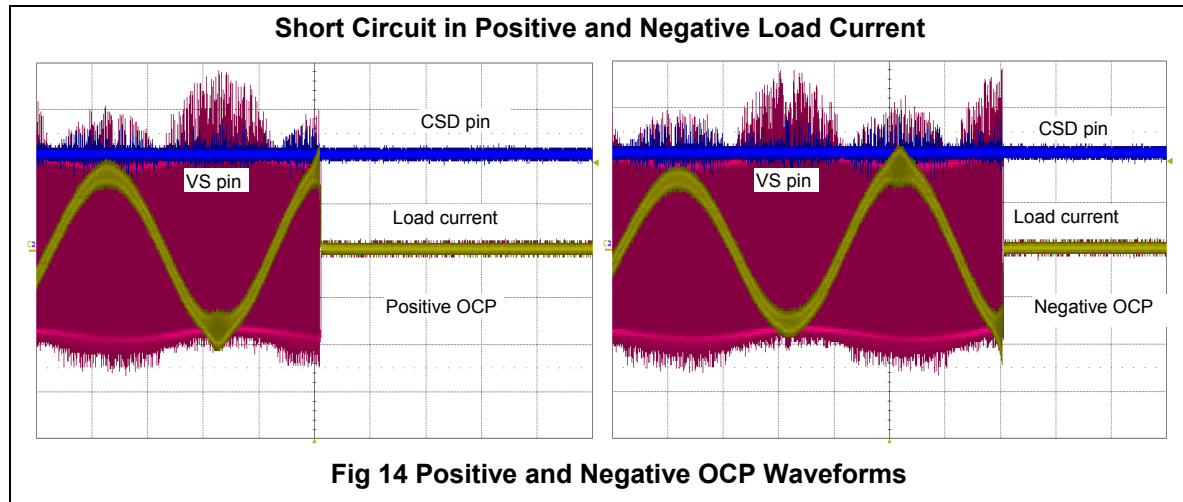

IRAUDAMP10 Overview

The IRAUDAMP10 features a 2CH self-oscillating type PWM modulator for the smallest space, highest performance and robust design. This topology represents an analog version of a second-order sigma-delta modulation having a Class D switching stage inside the loop. The benefit of the sigma-delta modulation, in comparison to the carrier-signal based modulation, is that all the error in the audible frequency range is shifted to the inaudible upper-frequency range by nature of its operation. Also, sigma-delta modulation allows a designer to apply a sufficient amount of error correction.

The IRAUDAMP10 self-oscillating topology consists of following essential functional blocks.

- Front-end integrator
- PWM comparator
- Level shifters
- Gate drivers and MOSFETs
- Output LPF

Integrator

Referring to Fig 16 below, the input operational amplifier of the IRS2052M forms a front-end second-order integrator with R3x, C2x, C3x, and R2x. The integrator that receives a rectangular feedback signal from the PWM output via R4x and audio input signal via R3x generates a quadratic carrier signal at the COMP pin. The analog input signal shifts the average value of the quadratic waveform such that the duty cycle varies according to the instantaneous voltage of the analog input signal.

PWM Comparator

The carrier signal at the COMP pin is converted to a PWM signal by an internal comparator that has a threshold at middle point between VAA and VSS. The comparator has no hysteresis in its input threshold.

Level Shifters

The internal input level-shifter transfers the PWM signal down to the low-side gate driver section. The gate driver section has another level-shifter that level shifts up the high-side gate signal to the high-side gate driver section.

Gate Drivers and DirectFETs

The received PWM signal is sent to the dead-time generation block where a programmable amount of dead time is added into the PWM signal between the two gate output signals of LO and HO to prevent potential cross conduction across the output power DirectFETs. The high-side level-shifter shifts up the high-side gate drive signal out of the dead-time block.

Each channel of the IRS2052M's drives two DirectFETs, high- and low-sides, in the power stage providing the amplified PWM waveform.

Output LPF

The amplified PWM output is reconstructed back to an analog signal by the output LC LPF. Demodulation LC low-pass filter (LPF) formed by L1 and C13, filters out the Class D switching carrier signal leaving the audio output at the speaker load. A single stage output filter can be used with switching frequencies of 500 kHz and greater; a design with a lower switching frequency may require an additional stage of LPF.

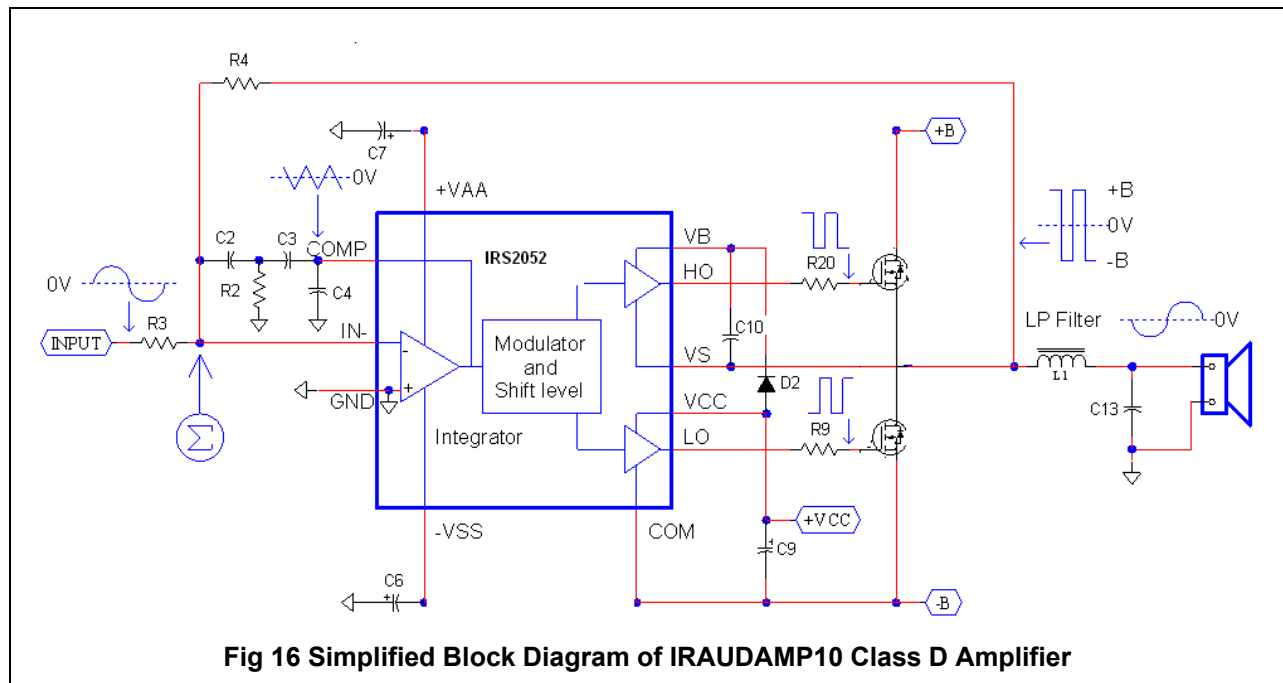

Functional Descriptions

IRS2052M Gate Driver IC

The IRAUDAMP10 uses the IRS2052M, a 2 Channel high-voltage (up to 200 V), high-speed power MOSFET driver with internal dead-time and protection functions specifically designed for Class D audio amplifier applications. These functions include OCP and UVP. The IRS2052M integrates bi-directional over current protection for both high-side and low-side MOSFETs. The dead-time can be selected for optimized performance according to the size of the MOSFET, minimizing dead-time while preventing shoot-through. As a result, there is no gate-timing adjustment required externally. Selectable dead-time through the DT pin voltage is an easy and reliable function which requires only two external resistors, R12 and R13 as shown on Fig 17 or Fig 23 below.

The IRS2052M offers the following functions.

- PWM modulator
- Dead-time insertion
- Over current protection
- Under voltage protection
- Level shifters

Refer to IRS2052M datasheet and AN-1159 for more details.

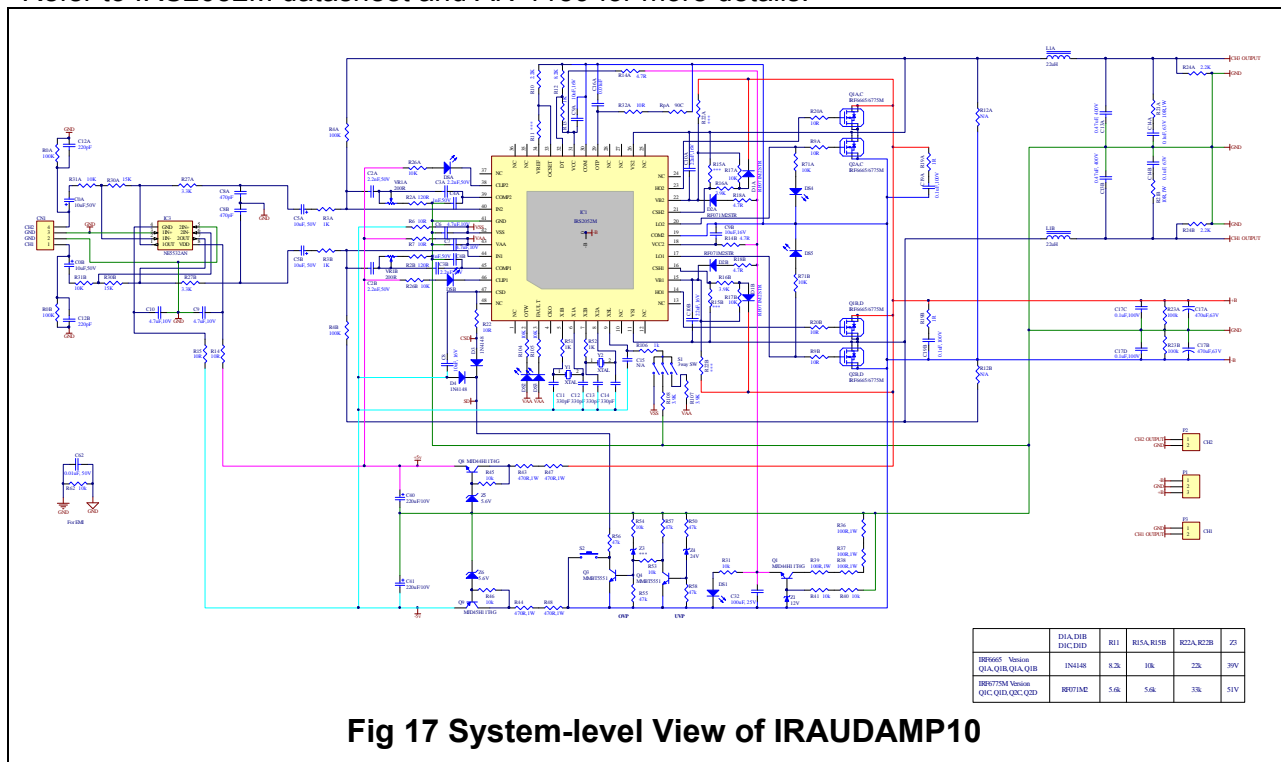

Fig 17 System-level View of IRAUDAMP10

Self-Oscillating Frequency

Self-oscillating frequency is determined by the total delay time along the control loop of the system; the propagation delay of the IRS2052M, the DirectFETs switching speed, the time-constant of front-end integrator (R2x, R3x, R4x, Vr1x, C2x, C3x). Variations in +B and –B supply voltages also affect the self-oscillating frequency.

The self-oscillating frequency changes with the duty ratio. The frequency is highest at idling. It drops as duty cycle varies away from 50%.

Adjustments of Self-Oscillating Frequency

Use VR1x to set different self-oscillating frequencies. The PWM switching frequency in this type of self-oscillating switching scheme greatly impacts the audio performance, both in absolute frequency and frequency relative to the other channels. In absolute terms, at higher frequencies, distortion due to switching-time becomes significant, while at lower frequencies, the bandwidth of the amplifier suffers. In relative terms, interference between channels is most significant if the relative frequency difference is within the audible range.

Normally, when adjusting the self-oscillating frequency of the different channels, it is suggested to either match the frequencies accurately, or have them separated by at least 25kHz. Under the normal operating condition with no audio input signal, the switching-frequency is set around 500kHz in the IRAUDAMP10.

Internal Clock Oscillator

The IRS2052M integrates two clock oscillators and synchronization networks for each PWM channel. To prevent AM radio reception interference, two PWM frequencies are selectable via XSL pin. As shown in Table 2, when XSL is bias to VAA, X1A and X1B are active. When XSL is GND X2A and X2B are active. When XSL is VSS, both clock oscillators are disabled.

| XSL pin | X1A/B | X2A/B |
|---------|-----------|-----------|
| VAA | Activated | Disabled |
| GND | Disabled | Activated |
| VSS | Disabled | Disabled |

CKO outputs internal clock with VAA/VSS amplitude. The CKO can distribute clock signal to multiple IRS2052 devices to synchronize PWM switching timing.

Selectable Dead-time

The dead-time of the IRS2052 is set based on the voltage applied to the DT pin. Fig 18 lists the suggested component value for each programmable dead-time between 45 and 105 ns. All the IRAUDAMP10 models use DT1 (45ns) dead-time.

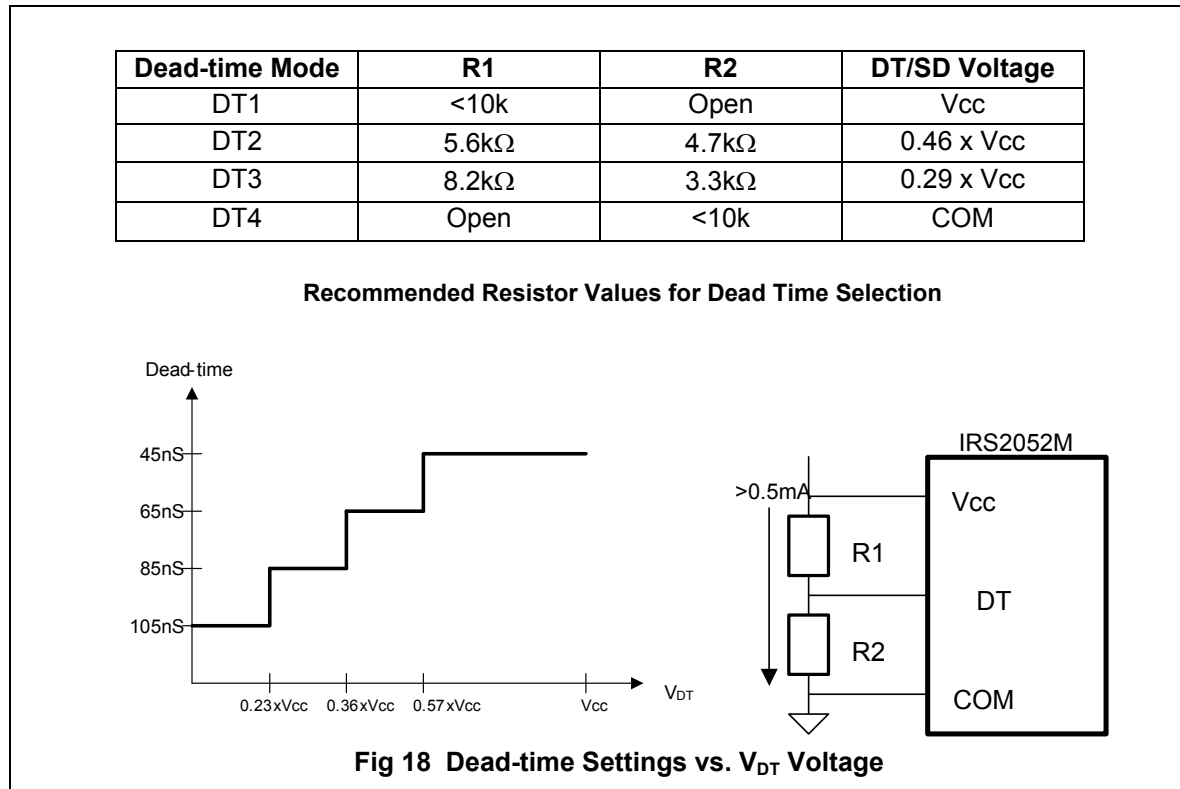

Protection System Overview

The IRS2052M integrates over current protection (OCP) inside the IC. The rest of the protections, such as over-voltage protection (OVP), under-voltage protection (UVP), and over temperature protection (OTP), are detected externally to the IRS2052M (Fig 19).

The external shutdown circuit will disable the output by pulling down CSD pins, (Fig 20). If the fault condition persists, the protection circuit stays in shutdown until the fault is removed.

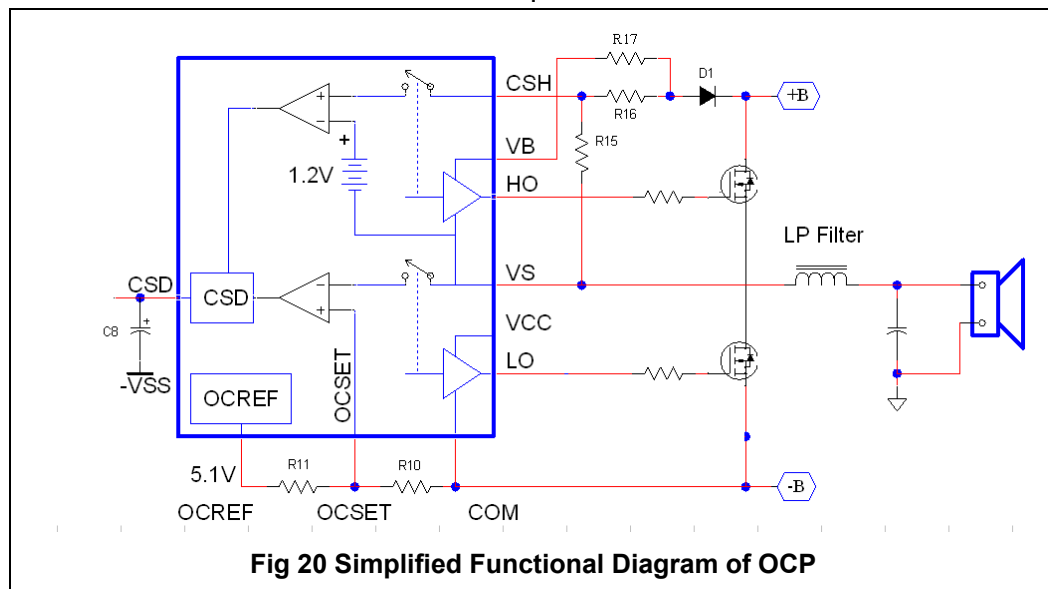
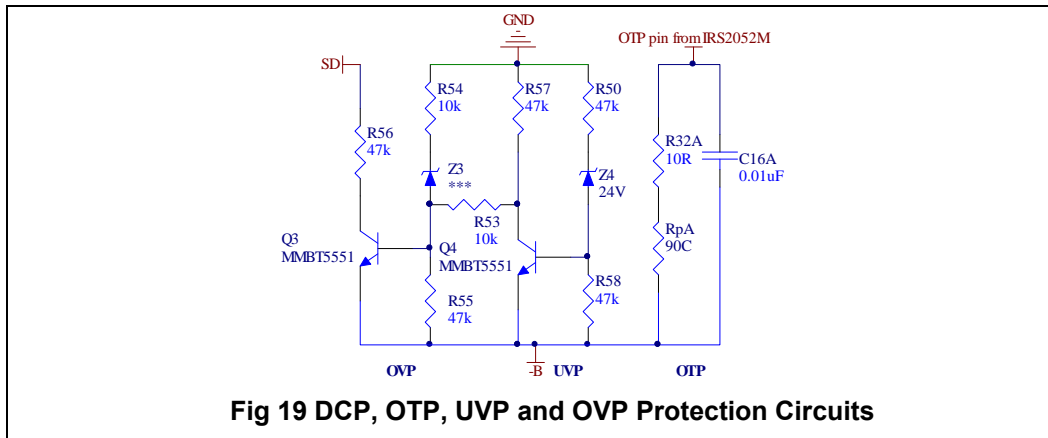

Over-Current Protection (OCP)

Low-Side Current Sensing

The low-side current sensing feature protects the low side DirectFET from an overload condition from negative load current by measuring drain-to-source voltage across $R_{DS(ON)}$ during its on state. OCP shuts down the switching operation if the drain-to-source voltage exceeds a preset trip level.

The voltage setting on the OCSET pin programs the threshold for low-side over-current sensing. When the VS voltage becomes higher than the OCSET voltage during low-side conduction, the IRS2052 turns the outputs off and pulls CSD down to -VSS.

High-Side Current Sensing

The high-side current sensing protects the high side DirectFET from an overload condition from positive load current by measuring drain-to-source voltage across $R_{DS(ON)}$ during its on state. OCP shuts down the switching operation if the drain-to-source voltage exceeds a preset trip level.

High-side over-current sensing monitors drain-to-source voltage of the high-side DirectFET during the on state through the CSH and VS pins. The CSH pin detects the drain voltage with reference to the VS pin, which is the source of the high-side DirectFET. In contrast to the low-side current sensing, the threshold of the CSH pin to trigger OC protection is internally fixed at 1.2V. An external resistive divider R15, R16 and R17 are used to program a threshold as shown in Fig 20. An external reverse blocking diode D1 is required to block high voltage feeding into the CSH pin during low-side conduction. By subtracting a forward voltage drop of 0.6V at D1, the minimum threshold which can be set for the high-side is 0.6V across the drain-to-source.

Over-Voltage Protection (OVP)

OVP is provided externally to the IRS2052M. OVP shuts down the amplifier if the bus voltage between GND and -B exceeds 51V. The threshold is determined by a Zener diode Z3. OVP protects the board from harmful excessive supply voltages, such as due to bus pumping at very low frequency-continuous output in stereo mode.

Under-Voltage Protection (UVP)

UVP is provided externally to the IRS2052M. UVP prevents unwanted audible noise output from unstable PWM operation during power up and down. UVP shuts down the amplifier if the bus voltage between GND and -B falls below a voltage set by Zener diode Z4.

Offset Null (DC Offset) Adjustment

The IRAUDAMP10 requires no output-offset adjustment. DC offsets are tested to be less than ± 20 mV.

Over-Temperature Protection (OTP)

The over temperature protection input OTP is for an external PTC Thermistor to monitor temperature of MOSFET. The OTP pin equips a 0.6mA internal current source to bias the external PTC resistor. Over temperature warning activates when the voltage at any of OTP input pin goes higher than 1.4V. Over temperature protection activates when the voltage at any of OTP input pin goes higher than 2.8V. A PTC thermistors, Rpa in Fig 19, is placed on bottom side PCB; which is close to the 4 DirectFETs; and monitors DirectFETs' temperature. If the temperature rises above 90 °C on the bottom side, make OTP input pin goes high and shuts down all 2 channels by pulling down the CSD pins of the IRS2052M. OTP recovers once the temperature cools down.

On-chip Over Temperature Protection

If the junction temperature T_J of IRS2052M becomes higher than on-chip thermal warning threshold 127°C, the on-chip over temperature protection pulls OTW pin down to GND. If the junction temperature T_J keeps increasing and exceed on-chip thermal shutdown threshold 147°C, the on-chip over temperature protection shuts down PWM, pulls OTW up to VAA and pulls FAULT pin down to GND as long as the junction temperature is higher than the threshold.

Over Temperature Warning Output (OTW)

OTW output is an open drain output referenced to GND to report whether the IRS2052M is experiencing high temperature from either OTP input or on-chip OTP. OTW activates if OTP pin voltage becomes higher than warning threshold, or if junction temperature reaches warning threshold.

Fault Output

FAULT output is an open drain output referenced to GND to report whether the IRS2052M is in shutdown mode or in normal operating condition. If FAULT pin is open, the IRS2052M is in normal operation mode.

Following conditions triggers shutdown internally and pulls FAULT pin down to GND.

- Over Current Protection
- Over Temperature Protection (internal or external via OTP pin)
- Shutdown mode from CSD pin voltage

Click and POP Noise Reduction

Thanks to the click and pop elimination function built into the IRS2052M, the IRAUDAMP10 does not require any additional components for this function.

Power Supply Requirements

For convenience, the IRAUDAMP10 has all the necessary housekeeping power supplies onboard and only requires a pair of symmetric power supplies.

House Keeping Power Supply

The internally-generated housekeeping power supplies include $\pm 5V$ for analog signal processing, and +12V supply (V_{CC}) referred to the negative supply rail -B for DirectFET gate drive. The gate driver section of the IRS2052M uses V_{CC} to drive gates of the DirectFETs. V_{CC} is referenced to -B (negative power supply). D2x, R18x and C10x form a bootstrap floating supply for the HO gate driver.

Bus Pumping

When the IRAUDAMP10 is running in stereo mode, the bus pumping effect takes place with low frequency, high output. Since the energy flowing in the Class D switching stage is bi-directional, there is a period where the Class D amplifier feeds energy back to the power supply. The majority of the energy flowing back to the supply is from the energy stored in the inductor in the output LPF. Usually, the power supply has no way to absorb the energy coming back from the load. Consequently the bus voltage is pumped up, creating bus voltage fluctuations.

Following conditions make bus pumping worse:

1. Lower output frequencies (bus-pumping duration is longer per half cycle)
2. Higher power output voltage and/or lower load impedance (more energy transfers between supplies)
3. Smaller bus capacitance (the same energy will cause a larger voltage increase)

The OVP protects IRAUDAMP10 from failure in case of excessive bus pumping. Bus voltage detection monitors only +B supply, assuming the bus pumping on the supplies is symmetric in +B and -B supplies.

Load Impedance

Each channel is optimized for a 4 Ω speaker load in half bridge.

Input Signal and Gain Setting

A proper input signal is an analog signal ranging from 20Hz to 20kHz with up to 3 V_{RMS} amplitude with a source impedance of no more than 600 Ω . Input signal with frequencies from 30kHz to 60kHz may cause LC resonance in the output LPF, causing a large reactive current flowing through the switching stage, especially with greater than 8 Ω load impedances, and the LC resonance can activate OCP.

The IRAUDAMP10 has an RC network called a Zobel network (R21 and C14) to damp the resonance and prevent peaking frequency response with light loading impedance. (Fig 21)

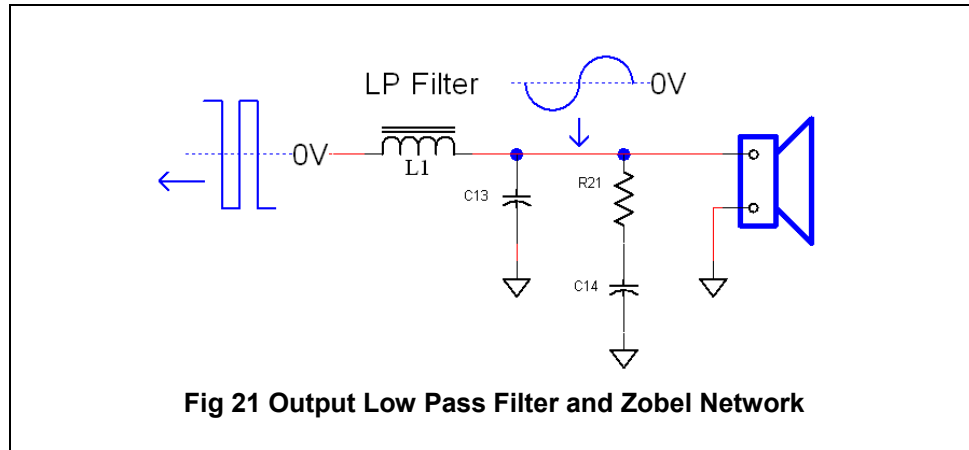

Gain Setting

The ratio of resistors $\{R4x/(R3x+R27x)\} \cdot (R30x/R31x)$ in Fig 22 sets voltage gain. The IRAUDAMP10 has no on board volume control. To change the voltage gain, change the input resistor term R27x and R3x. Changing R4x affects PWM control loop design and may result poor audio performance.

Schematic

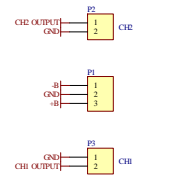
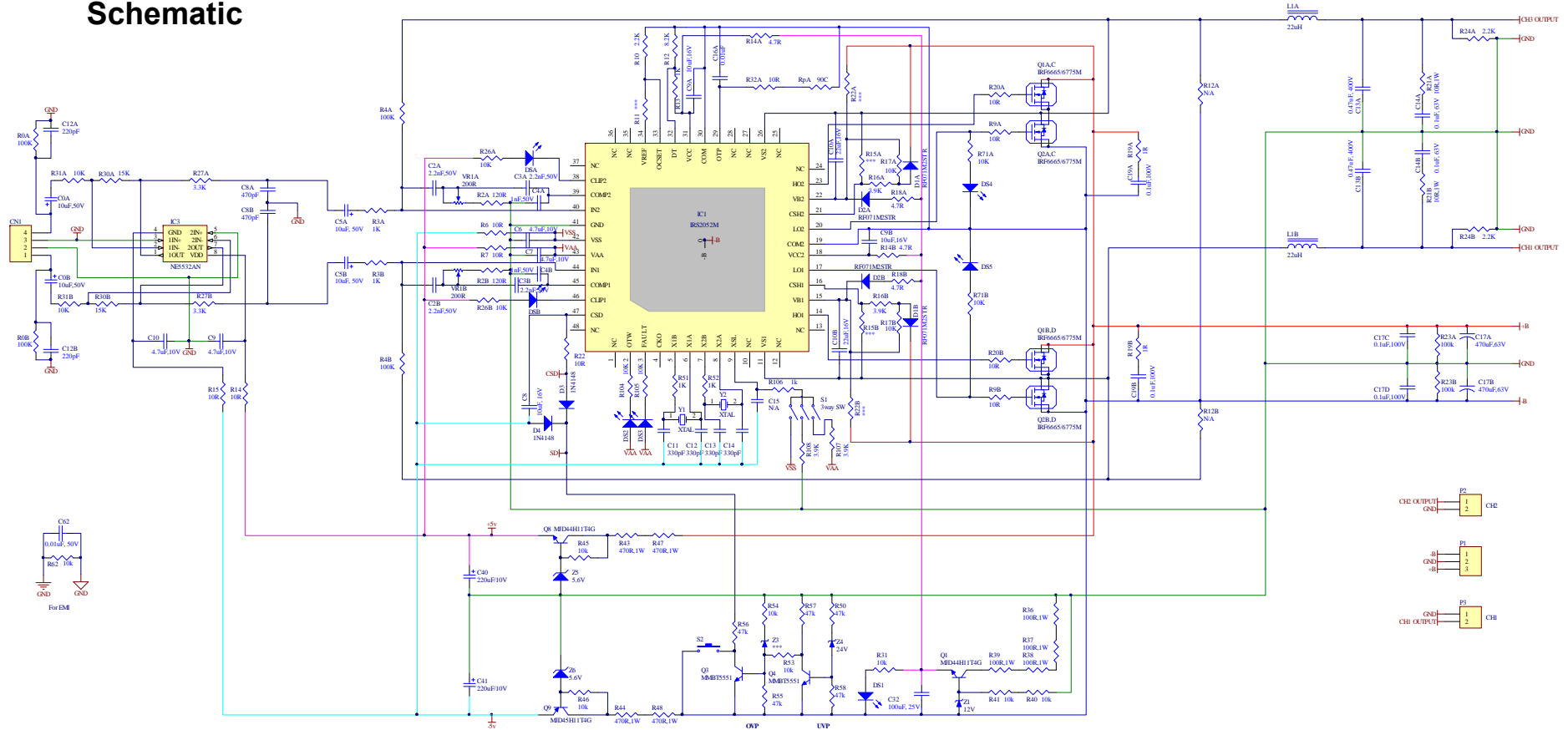

| | D1A, D1B D1C, D1D | R11 | R15A, R15B | R22A, R22B | Z1 |
|--------------------------------------|----------------------|------|------------|------------|-----|
| IRF665 Version Q1A, Q1B, Q1A, Q1B | 1N4148 | 8.2k | 10k | 22k | 39V |
| IRF75M Version Q1C, Q1D, Q2C, Q2D | RFU71M2 | 5.6k | 5.6k | 33k | 51V |

Fig 22 IRAUDAMP10 Schematic

IRAUDAMP10 Fabrication Materials

Table 1 IRAUDAMP10 Electrical Bill of Materials

| Quantity | Value | Description | Designator | Part Number | Vender |
|----------|--------------|--|------------------------|--------------------|---------------------------------------|
| 4 | 10uF, 50V | CAP 10UF 50V ELECT SMG RAD | C0A, C0B, C5A, C5B | 565-1106-ND | United Chemi-Con |
| 4 | 2.2nF, 50V | CAP CER 2200PF 50V 10% X7R 0603 | C2A, C2B, C3A, C3B | 490-1500-1-ND | Murata Electronics North America |
| 2 | 1nF, 50V | CAP 1000PF 50V CERAMIC X7R 0603 | C4A, C4B | 399-1082-1-ND | Kemet |
| 4 | 4.7uF, 10V | CAP CERM 4.7UF 10V Y5V 0805 | C6, C7, C9, C10 | 478-1429-1-ND | AVX Corporation |
| 1 | 10uF, 16V | CAP CER 10UF 16V Y5V 1206 | C8 | 490-3383-1-ND | Murata Electronics North America |
| 2 | 470pF | Polypropylene Film Capacitors 100V 470pF 5% | C8A, C8B | 505-FKP2470/100/5 | WIMA |
| 2 | 10uF, 16V | CAP CER 10UF 16V Y5V 0805 | C9A, C9B | 490-3347-1-ND | Murata Electronics North America |
| 2 | 22uF, 16V | CAP CER 22UF 16V X7R 1210 | C10A, C10B | 445-3945-1-ND | TDK Corporation |
| 4 | 330pF, 50V | CAP CER 330PF 50V X7R 0603 | C11, C12, C13, C14 | 445-5074-1-ND | TDK Corporation |
| 2 | 220pF | CAP CER 220PF 50V 10% X7R 0603 | C12A, C12B | 490-1483-1-ND | Murata Electronics North America |
| 2 | 0.47uF, 400V | CAP .47UF 400V METAL POLYPRO | C13A, C13B | 495-1315-ND | EPCOS Inc |
| 2 | 0.1uF, 63V | CAP FILM MKP .1UF 63VDC 2% | C14A, C14B | BC2054-ND | Vishay/BC Components |
| 2 | 0.01uF, 50V | CAP CER 10000PF 50V 10% X7R 0603 | C16A, C62 | 490-1512-1-ND | Murata Electronics North America |
| 2 | 470uF, 63V | CAP 470UF 63V ELECT SMG RAD | C17A, C17B | 565-1131-ND | United Chemi-Con |
| 4 | 0.1uF, 100V | CAP CER .10UF 100V X7R 10% 0805 | C17C, C17D, C19A, C19B | 445-1418-1-ND | TDK Corporation |
| 1 | 100uF, 25V | CAP 100UF 25V ELECT SMG RAD | C32 | 565-1059-ND | United Chemi-Con |
| 2 | 220uF, 10V | CAP 220UF 10V ELECT SMG RAD | C40, C41 | 565-1021-ND | United Chemi-Con |
| 1 | INPUT | TERMINAL BLOCK 3.5MM 4POS PCB | CN1 | ED1516-ND | On Shore Technology Inc |
| 4 | RF071M2STR | DIODE 200V 700MA SOD123 | D1A, D1B, D2A, D2B | RF071M2SCT-ND | Rohm Semiconductor |
| 2 | 1N4148 | DIODE SWITCH 100V 400MW SOD123 | D3, D4 | 1N4148W-FDICT-ND | Diodes Inc |
| 1 | LED AMBER | LED AMBER CLR THIN 0805 SMD | DS1 | 160-1419-1-ND | Lite-On Inc |
| 2 | LED RED | LED SUPER RED CLEAR 0805 SMD | DS2, DS3 | 160-1415-1-ND | Lite-On Inc |
| 2 | LED BLUE | LED 468NM BLUE CLEAR 0805 SMD | DS4, DS5 | 160-1645-1-ND | Lite-On Inc |
| 2 | LED GREEN | LED GREEN CLEAR 0805 SMD | DSA, DSB | 160-1414-1-ND | Lite-On Inc |
| 1 | IRS2052M | 2ch Audio Class D Controller | IC1 | IR2052MPBF | International Rectifier |
| 1 | NE5532AN | IC OPAMP DUAL LOW NOISE 8-DIP | IC3 | NE5532ANGOS-ND | ON Semiconductor |
| 2 | 22uH | Class D inductor, 22uH | L1A, L1B | 7G17A-220M | Inductors, Inc./SAGAMI ELEC CO., LTD. |
| 1 | Header 3 | CONN TERM BLOCK PCB 5.0MM 3POS | P1 | 281-1415-ND | Weidmuller |
| 2 | SP OUT | CONN TERM BLOCK PCB 5.0MM 2POS | P2, P3 | 281-1414-ND | Weidmuller |
| 2 | MJD44H11T4G | TRANS PWR NPN 8A 80V DPAK | Q1, Q8 | MJD44H11T4GOSCT-ND | ON Semiconductor |
| 4 | IRF6775MPBF | MOSFET, 150V, 28A, 47 mOhm, 25 nC Qg, Med Can, optimized for Audio | Q1A, Q1B, Q2A, Q2B | IRF6775MTR1PBF | International Rectifier |

| | | | | | |
|----|-------------|---|---|--------------------|----------------------------------|
| 0 | N/A | MOSFET, 100V, 19A, 62 mOhm, 8.7 nC Qg, Small Can, optimized for Audio | Q1C, Q1D, Q2C, Q2D | IRF6665TR1PBF | International Rectifier |
| 2 | MMBT5551 | TRANS NPN 160V 350MW SMD SOT23-3 | Q3, Q4 | MMBT5551-FDICT-ND | Diodes Inc |
| 1 | MJD45H11T4G | TRANS PWR PNP 8A 80V DPAK | Q9 | MJD45H11T4GOSCT-ND | ON Semiconductor |
| 4 | 100K | RES 100K OHM 1/10W 5% 0603 SMD | R0A, R0B, R23A, R23B | RHM100KGCT-ND | Rohm Semiconductor |
| 2 | 120R | RES 120 OHM 1/10W 5% 0603 SMD | R2A, R2B | RHM120GCT-ND | Rohm Semiconductor |
| 2 | 1K | RES 1.00K OHM 1/8W 1% 0805 SMD | R3A, R3B | RHM1.00KCRCT-ND | Rohm Semiconductor |
| 2 | 100K | RES 100K OHM 1/8W 1% 0805 SMD | R4A, R4B | RHM100KCRCT-ND | Rohm Semiconductor |
| 10 | 10R | RES 10 OHM 1/10W 5% 0603 SMD | R6, R7, R9A, R9B, R14, R15, R20A, R20B, R22, R32A | RHM10GCT-ND | Rohm Semiconductor |
| 1 | 2.2K | RES 2.2K OHM 1/10W 5% 0603 SMD | R10 | RHM2.2KGCT-ND | Rohm Semiconductor |
| 3 | 5.6K | RES 5.6K OHM 1/10W 5% 0603 SMD | R11, R15A, R15B | RHM5.6KGCT-ND | Rohm Semiconductor |
| 1 | 8.2K | RES 8.2K OHM 1/10W 5% 0603 SMD | R12 | RHM8.2KGCT-ND | Rohm Semiconductor |
| 0 | N/A | | R12A, R12B | N/A | |
| 5 | 1K | RES 1.0K OHM 1/10W 5% 0603 SMD | R13, R51, R52, R106, R108 | RHM1.0KGCT-ND | Rohm Semiconductor |
| 4 | 4.7R | RES 4.7 OHM 1/10W 5% 0603 SMD | R14A, R14B, R18A, R18B | RHM4.7GCT-ND | Rohm Semiconductor |
| 3 | 3.9K | RES 3.9K OHM 1/10W 5% 0603 SMD | R16A, R16B, R107 | RHM3.9KGCT-ND | Rohm Semiconductor |
| 13 | 10K | RES 10K OHM 1/10W 5% 0603 SMD | R17A, R17B, R26A, R26B, R45, R46, R53, R54, R62, R71A, R71B, R104, R105 | RHM10KGCT-ND | Rohm Semiconductor |
| 2 | 1R | RES 1.0 OHM 1/8W 5% 0805 SMD | R19A, R19B | RHM1.0ARCT-ND | Rohm Semiconductor |
| 2 | 10R,1W | RES 10 OHM 1W 1% 2512 SMD | R21A, R21B | PT10AECT-ND | Panasonic - ECG |
| 2 | 33K | RES 33.0K OHM 1/8W 1% 0805 SMD | R22A, R22B | RHM33.0KCRCT-ND | Rohm Semiconductor |
| 2 | 2.2K | RES 2.2K OHM 1/8W 5% 0805 SMD | R24A, R24B | RHM2.2KARCT-ND | Rohm Semiconductor |
| 2 | 3.3K | RES 3.3K OHM 1/10W 5% 0603 SMD | R27A, R27B | RHM3.3KGCT-ND | Rohm Semiconductor |
| 2 | 15K | RES 15.0K OHM 1/8W 1% 0805 SMD | R30A, R30B | RHM15.0KCRCT-ND | Rohm Semiconductor |
| 5 | 10K | RES 10.0K OHM 1/8W 1% 0805 SMD | R31, R31A, R31B, R40, R41 | RHM10.0KCRCT-ND | Rohm Semiconductor |
| 4 | 100R,1W | RES 100 OHM 1W 5% 2512 SMD | R36, R37, R38, R39 | PT100XCT-ND | Panasonic - ECG |
| 4 | 470R,1W | RES 470 OHM 1W 5% 2512 SMD | R43, R44, R47, R48 | PT470XCT-ND | Panasonic - ECG |
| 5 | 47K | RES 47K OHM 1/10W 5% 0603 SMD | R50, R55, R56, R57, R58 | RHM47KGCT-ND | Rohm Semiconductor |
| 1 | 90C | Thermistors - PTC PTC Temp Prot. 90C | RpA | 594-2381-675-20907 | Vishay/BC Components |
| 1 | 3way SW | SWITCH ROTARY SP-3POS SMD | S1 | 401-1962-1-ND | C&K Components |
| 1 | SW-PB | 6MM LIGHT TOUCH SW H=5 | S2 | P8010S-ND | Panasonic - ECG |
| 2 | 200R VR | POT 200 OHM 3MM CERM SQ TOP SMD | VR1A, VR1B | ST32ETB201CT-ND | Copal Electronics Inc |
| 1 | XTAL | CER RESONATOR 400KHz | Y1 | 490-1186-ND | Murata Electronics North America |
| 1 | XTAL | CER RESONATOR 455KHz | Y2 | 490-1187-ND | Murata Electronics North America |
| 1 | 12V | DIODE ZENER 12V 500MW SOD-123 | Z1 | BZT52C12-FDICT-ND | Diodes Inc |

| | | | | | |
|---|------|-----------------------------------|--------|-----------------------|------------------|
| 1 | 51V | DIODE ZENER 51V 410MW SOD-123 | Z3 | BZT52C51-FDICT-ND | Diodes Inc |
| 1 | 24V | DIODE ZENER 24V 500MW SOD-123 | Z4 | BZT52C24-FDICT-ND | Diodes Inc |
| 2 | 5.6V | DIODE ZENER 5.6V 500MW SOD-123 | Z5, Z6 | MMSZ5V6T1GOSCT- ND | ON Semiconductor |

Table 2 IRAUDAMP10 Mechanical Bill of Materials

| Quantity | Value | Description | Designator | Digikey P/N | Vendor |
|----------|---------------------|---|---|-------------|------------------------------|
| 7 | Washer #4 SS | WASHER LOCK INTERNAL #4 SS | Lock washer 1, Lock washer 2, Lock washer 3, Lock washer 4, Lock washer 5, Lock washer 6 Lock washer 7 | H729-ND | Building Fasteners |
| 1 | PCB | Print Circuit Board IRAUDAM11 Rev 3.0 .PCB | PCB 1 | | Custom |
| 7 | Screw 4- 40X5/16 | SCREW MACHINE PHILLIPS 4-40X5/16 | Screw 1, Screw 2, Screw 3, Screw 4, Screw 5, Screw 6, Screw 7, | H343-ND | Building Fasteners |
| 4 | Stand off 0.5" | STANDOFF HEX 4- 40THR .500"L ALUM | Stand Off 1, Stand Off 2, Stand Off 3, Stand Off 4 | 1893K-ND | Keystone Electro- nics |
| 1/16 | AAVID 4880G | THERMAL PAD .080" 4X4" GAPPAD | thermal pad under heatsink | BER164-ND | Therm- alloy |

IRAUDAMP10 Hardware

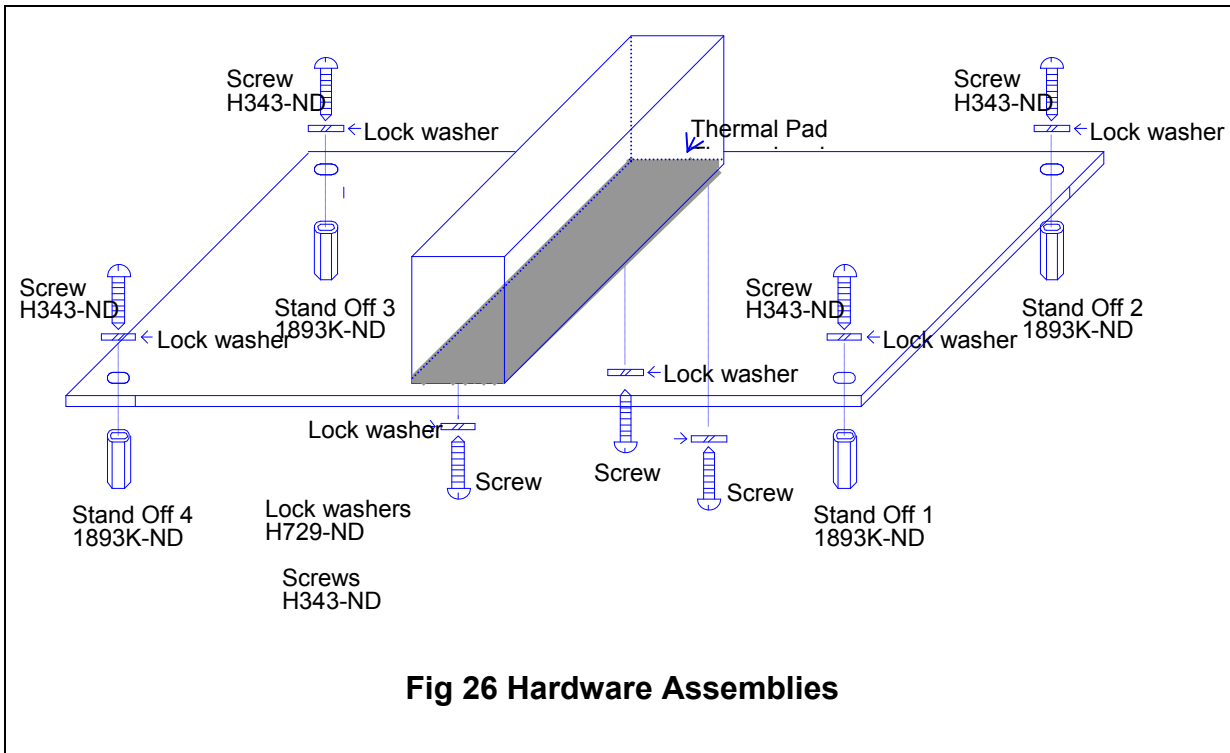
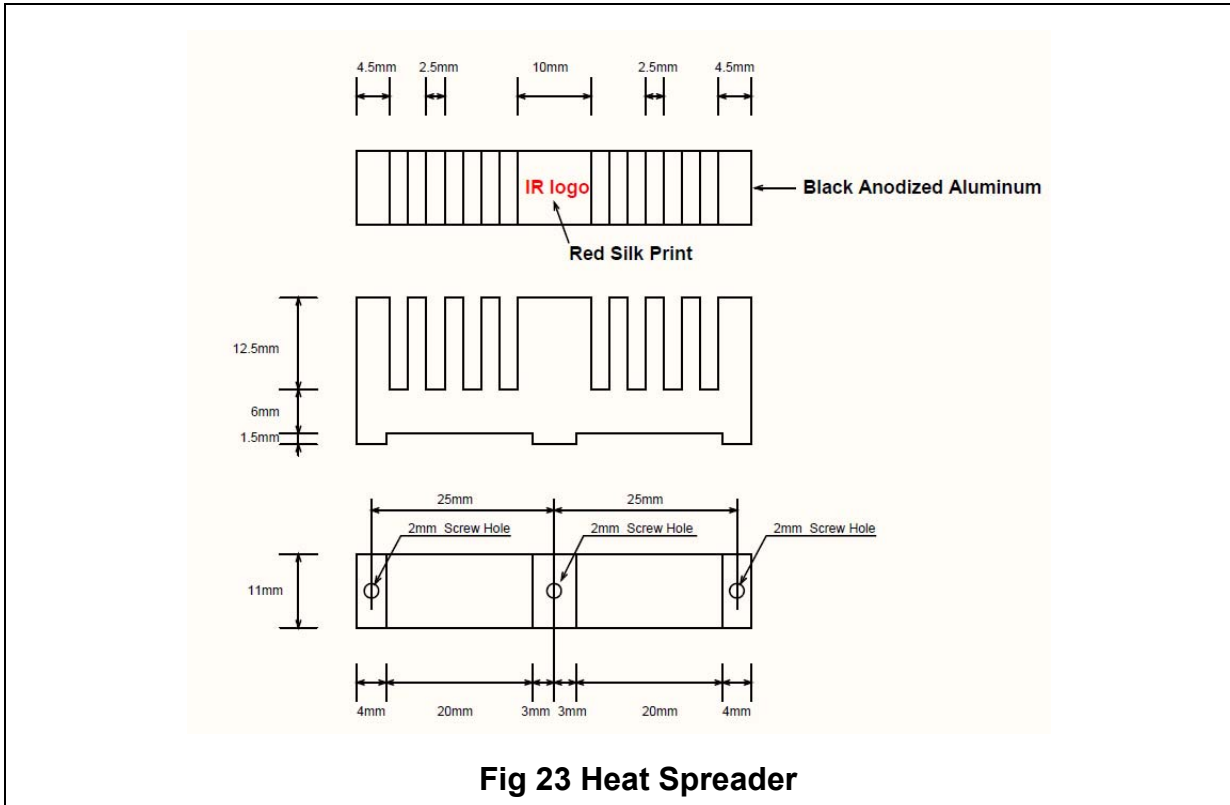

IRAUDAMP10 PCB Specifications

PCB:

1. Two Layers SMT PCB with through holes
2. 1/16 thickness
3. 2/0 OZ Cu
4. FR4 material
5. 10 mil lines and spaces
6. Solder Mask to be Green enamel EMP110 DBG (CARAPACE) or Enthone Endplate DSR-3241 or equivalent.
7. Silk Screen to be white epoxy non conductive per IPC-RB 276 Standard.
8. All exposed copper must finished with TIN-LEAD Sn 60 or 63 for 100u inches thick.
9. Tolerance of PCB size shall be 0.010 -0.000 inches
10. Tolerance of all Holes is -.000 + 0.003"
11. PCB acceptance criteria as defined for class II PCB'S standards.

Gerber Files Apertures Description:

All Gerber files stored in the attached CD-ROM were generated from Protel Altium Designer Altium Designer 6. Each file name extension means the following:

1. .gtl Top copper, top side
2. .gbl Bottom copper, bottom side
3. .gto Top silk screen
4. .gbo Bottom silk screen
5. .gts Top Solder Mask
6. .gbs Bottom Solder Mask
7. .gko Keep Out,
8. .gm1 Mechanical1
9. .gd1 Drill Drawing
10. .gg1 Drill locations
11. .txt CNC data
12. .apr Apertures data

Additional files for assembly that may not be related with Gerber files:

13. .pcb PCB file
14. .bom Bill of materials
15. .cpl Components locations
16. .sch Schematic
17. .csv Pick and Place Components
18. .net Net List
19. .bak Back up files
20. .lib PCB libraries

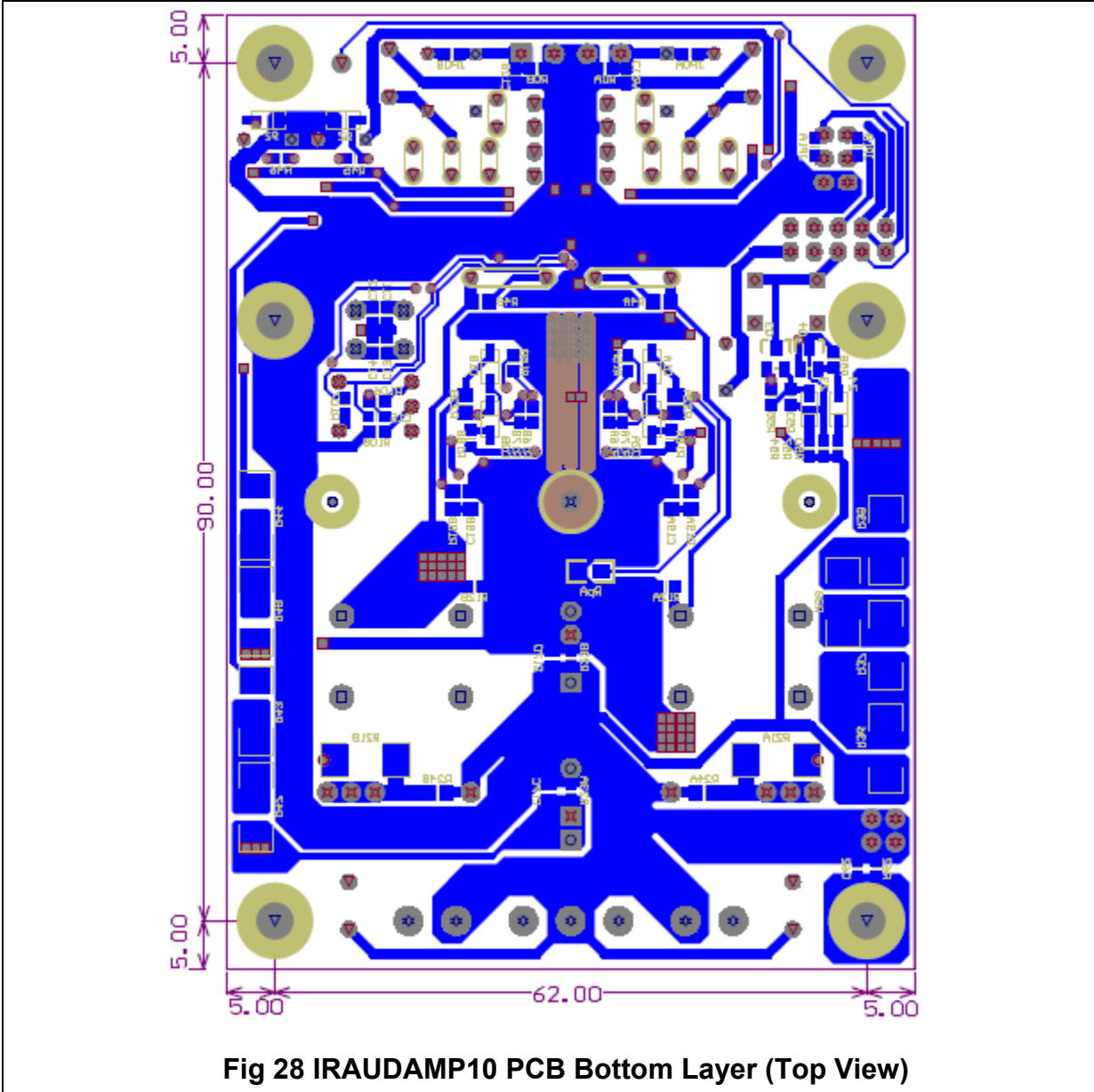

Fig 28 IRAUDAMP10 PCB Bottom Layer (Top View)

Revision changes descriptions

| Revision | Changes description | Date |
|----------|---|----------------|
| Rev 1.0 | Released | March, 29 2011 |
| Rev 1.1 | Correct polarity of XSL pin function in Internal Clock Oscillator | Jan, 25 2012 |



Стандарт Электрон Связь

Мы молодая и активно развивающаяся компания в области поставок электронных компонентов. Мы поставляем электронные компоненты отечественного и импортного производства напрямую от производителей и с крупнейших складов мира.

Благодаря сотрудничеству с мировыми поставщиками мы осуществляем комплексные и плановые поставки широчайшего спектра электронных компонентов.

Собственная эффективная логистика и склад в обеспечивает надежную поставку продукции в точно указанные сроки по всей России.

Мы осуществляем техническую поддержку нашим клиентам и предпродажную проверку качества продукции. На все поставляемые продукты мы предоставляем гарантию .

Осуществляем поставки продукции под контролем ВП МО РФ на предприятия военно-промышленного комплекса России , а также работаем в рамках 275 ФЗ с открытием отдельных счетов в уполномоченном банке. Система менеджмента качества компании соответствует требованиям ГОСТ ISO 9001.

Минимальные сроки поставки, гибкие цены, неограниченный ассортимент и индивидуальный подход к клиентам являются основой для выстраивания долгосрочного и эффективного сотрудничества с предприятиями радиоэлектронной промышленности, предприятиями ВПК и научно-исследовательскими институтами России.

С нами вы становитесь еще успешнее!

Наши контакты:

Телефон: +7 812 627 14 35

Электронная почта: sales@st-electron.ru

Адрес: 198099, Санкт-Петербург,
Промышленная ул, дом № 19, литера Н,
помещение 100-Н Офис 331