

# DUAL OPERATIONAL AMPLIFIER

**IL4560**

## GENERAL DESCRIPTION

The IL4560 integrated circuit is a high-gain, wide bandwidth, dual operational amplifier capable of driving 20 V peak-to-peak into 400 Ω loads. The IL4560 combines many of the features of the IL4558 as well as providing the capability of wider bandwidth, and higher slew rate make the IL4560 ideal for active filters, data and telecommunications, and many instrumentation applications.

## FEATURES

- Operating Voltage ( $\pm 4\text{ V} \sim \pm 18\text{ V}$ )
- Wide Gain Bandwidth Product (10 MHz typ.)
- Slew Rate (4 V/μs typ.)
- Bipolar Technology

## BLOCK DIAGRAM

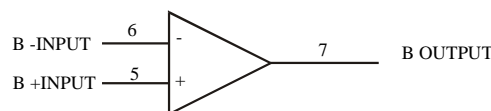
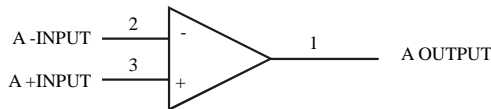

## EQUIVALENT CIRCUIT (1/2 Show)

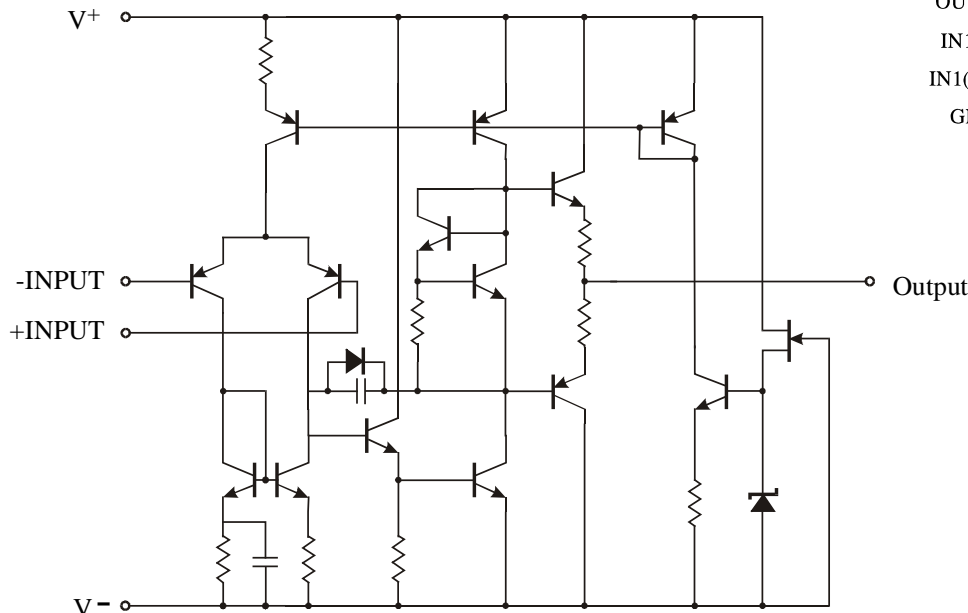

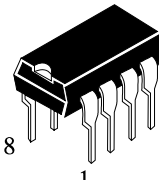

N SUFFIX  
PLASTIC

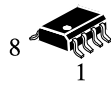

D SUFFIX  
SOIC

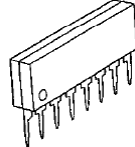

**ORDERING INFORMATION**  
 IL4560N Plastic  
 IL4560D SOIC  
 IL4560S SIP-8  
 $T_A = -25^\circ \text{ to } 75^\circ \text{ C}$   
 for all packages.

## PIN ASSIGNMENT

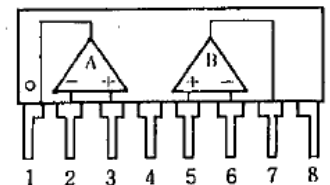

OUT 1	1	8	V <sub>CC</sub>
IN1(-)	2	7	OUT 2
IN1(+)	3	6	IN2(-)
GND	4	5	IN2(+)

**ABSOLUTE MAXIMUM RATINGS** (Ta=25°C)

Symbol	Parameter	Ratings	Unit
V <sup>+</sup> /V <sup>-</sup>	Supply Voltage	±18	V
V <sub>ID</sub>	Differential Input Voltage	30	V
V <sub>IC</sub>	Input Voltage	±15*	V
T <sub>opr</sub>	Operation Temperature Range	-25 ~ +75	°C
T <sub>stg</sub>	Storage Temperature Range	-60 ~ +125	°C
P <sub>D</sub>	Power Dissipation		
	DIP-8	500	mW
	SOP-8	300	
	SIP-8	800	

\* For supply voltage less than ±15 V, the absolute maximum input voltage is equal to the supply voltage.

\*\* Stresses beyond those listed under “absolute maximum ratings” may cause permanent damage to the device.

These are stress ratings only, and functional operation of the device at these or any other conditions beyond those indicated under “recommended operating conditions” is not implied.

Exposure to absolute-maximum-rated conditions for extended periods may affect device reliability.

**ELECTRICAL CHARACTERISTICS**

Symbol	Parameter	Test Condition	Min	Max	Unit
V <sub>IO</sub>	Input Offset Voltage	R <sub>S</sub> ≤ 10 kΩ	-	6	mV
I <sub>IO</sub>	Input Offset Current		-	200	nA
I <sub>B</sub>	Input Bias Current		-	500	nA
R <sub>IN</sub>	Input Resistance		0.3	-	MΩ
A <sub>V</sub>	Large Signal Voltage Gain	R <sub>L</sub> ≥ 2 kΩ, V <sub>O</sub> = ±10 V	86	-	dB
V <sub>OM1</sub>	Maximum Output Voltage Swing 1	R <sub>L</sub> ≥ 2 kΩ	±12	-	V
V <sub>OM2</sub>	Maximum Output Voltage Swing 2	I <sub>O</sub> = 25 mA	±10	-	V
V <sub>ICM</sub>	Input Common Mode Voltage Range		±12	-	V
CMR	Common Mode Rejection Ratio	R <sub>S</sub> ≤ 10 kΩ	70	-	dB
SVR	Supply Voltage Rejection Ratio	R <sub>S</sub> ≤ 10 kΩ	76.5	-	dB
I <sub>CC</sub>	Operating Current		-	5.7	mA
SR	Slew Rate	R <sub>L</sub> ≥ 2 kΩ	3	5	V/μs

■ TYPICAL CHARACTERISTICS

**Open Loop Voltage Gain vs. Frequency**

( $V^+/V^- = \pm 15V$ ,  $R_L = 2k\Omega$ ,  $T_a = 25^\circ C$ )

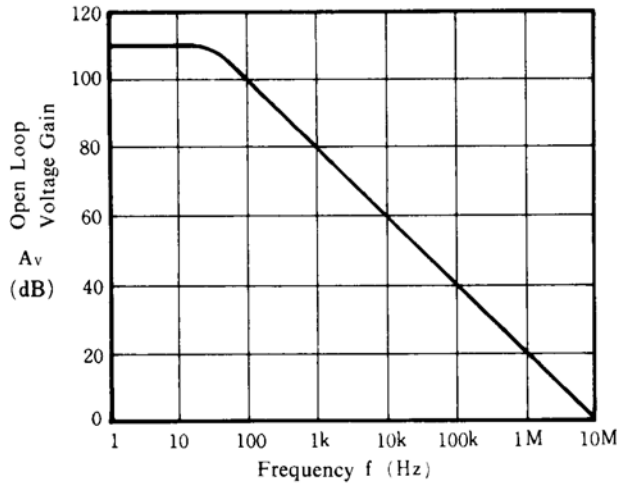

**Maximum Output Voltage Swing vs. Frequency**

( $V^+/V^- = \pm 15V$ ,  $T_a = 25^\circ C$ )

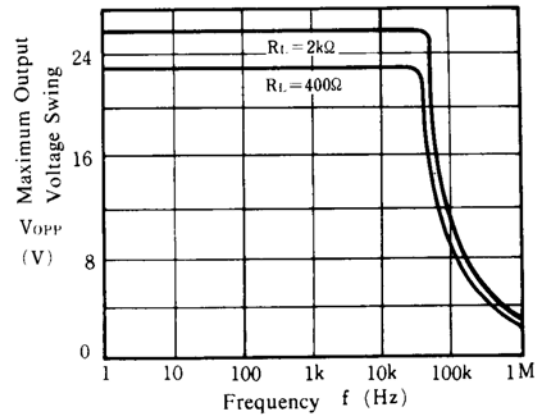

**Maximum Output Voltage Swing vs. Load Resistance**

( $V^+/V^- = \pm 15V$ ,  $T_a = 25^\circ C$ )

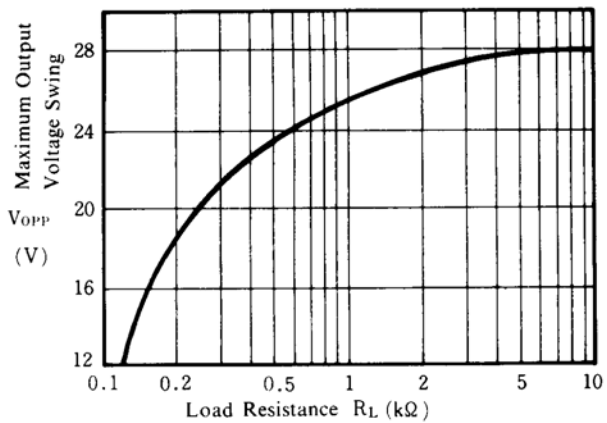

**Equivalent Input Noise Voltage vs. Frequency**

( $V^+/V^- = \pm 15V$ ,  $R_s = 50\Omega$ ,  $A_v = 60dB$ ,  $T_a = 25^\circ C$ )

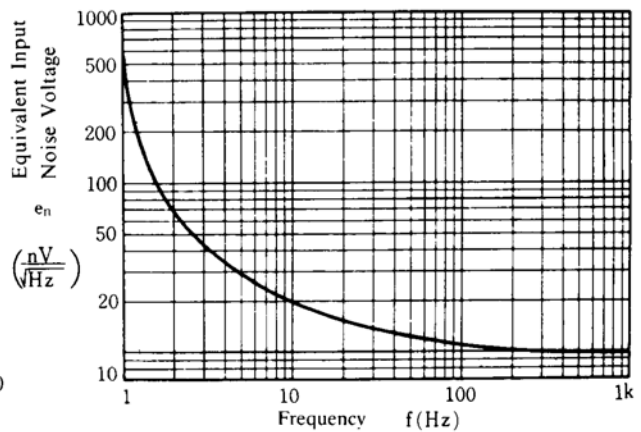

**Operating Current vs. Temperature**

( $V^+/V^- = \pm 15V$ )

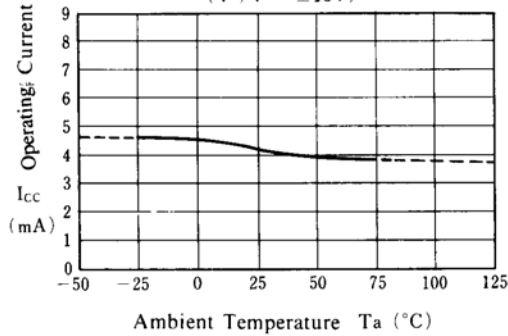

**Maximum Output Voltage Swing vs. Temperature**

( $V^+/V^- = \pm 15V$ ,  $R_L = 2k\Omega$ )

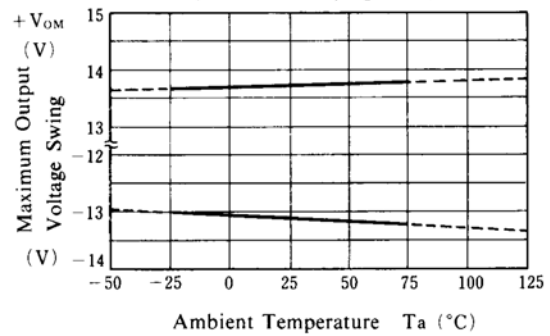

■ TYPICAL CHARACTERISTICS

Input Offset Voltage vs. Temperature

( $V^+/V^- = \pm 15V$ )

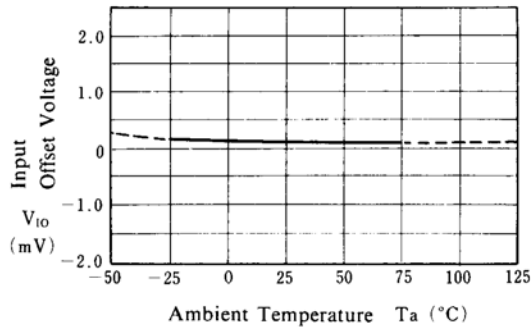

Input Bias Current vs. Temperature

( $V^+/V^- = \pm 15V$ )

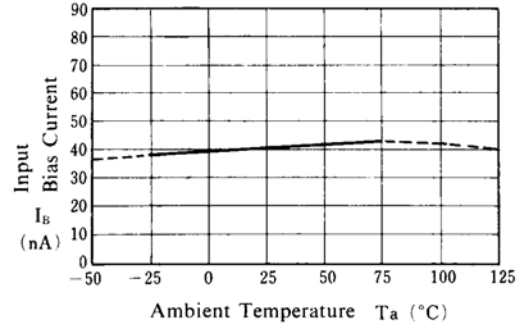

Maximum Output Voltage Swing vs. Supply Voltage

( $R_L = 400\Omega$ ,  $T_a = 25^\circ C$ )

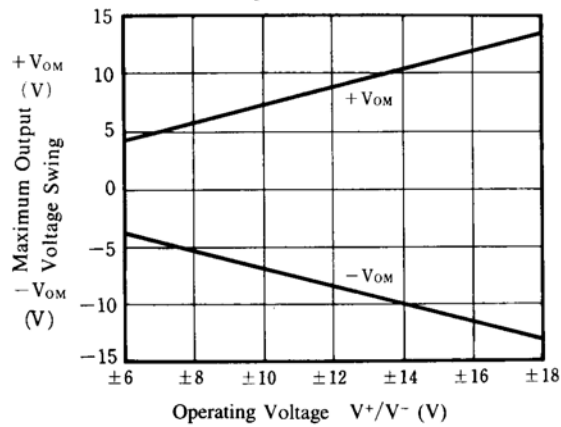

Operating Current vs. Operating Voltage

( $T_a = 25^\circ C$ )

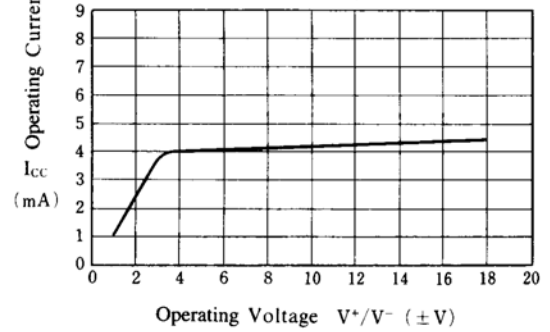

**N SUFFIX PLASTIC DIP  
(MS – 001BA)**

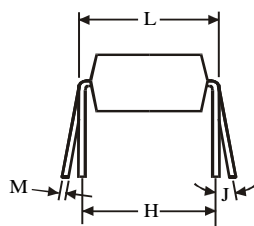
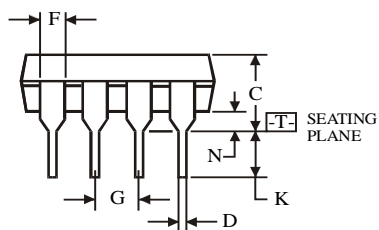
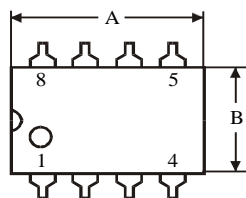
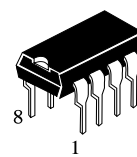

$\oplus 0.25 (0.010) \text{ (M) T}$

	Dimension, mm	
Symbol	MIN	MAX
A	8.51	10.16
B	6.1	7.11
C		5.33
D	0.36	0.56
F	1.14	1.78
G	2.54	
H	7.62	
J	0°	10°
K	2.92	3.81
L	7.62	8.26
M	0.2	0.36
N	0.38	

**NOTES:**

- Dimensions “A”, “B” do not include mold flash or protrusions.  
Maximum mold flash or protrusions 0.25 mm (0.010) per side.

**D SUFFIX SOIC  
(MS - 012AA)**

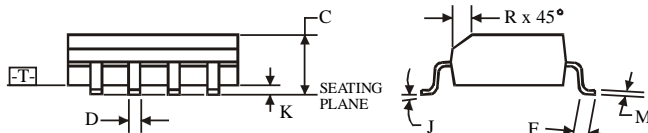
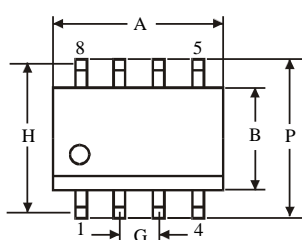
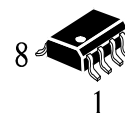

$\oplus 0.25 (0.010) \text{ (M) T C (M)}$

	Dimension, mm	
Symbol	MIN	MAX
A	4.8	5
B	3.8	4
C	1.35	1.75
D	0.33	0.51
F	0.4	1.27
G	1.27	
H	5.72	
J	0°	8°
K	0.1	0.25
M	0.19	0.25
P	5.8	6.2
R	0.25	0.5

**NOTES:**

- Dimensions A and B do not include mold flash or protrusion.
- Maximum mold flash or protrusion 0.15 mm (0.006) per side for A; for B - 0.25 mm (0.010) per side.

### 8-Pin Plastic Single-in-Line (SIP)

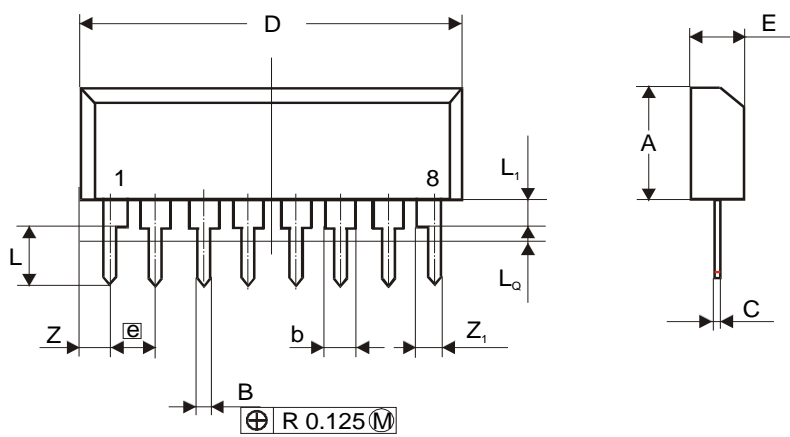

Dimension	mm	
	min	max
A	6.24	6.60
B	0.40	0.54
b	1.15	1.40
C	0.23	0.35
D	19.68	20.20
E	2.675	2.925
e	2.54	
L	2.95	3.25
L <sub>1</sub>	1.61	1.97
L <sub>0</sub>		0.70
Z		1.21
Z <sub>1</sub>		1.40



## Стандарт Электрон Связь

Мы молодая и активно развивающаяся компания в области поставок электронных компонентов. Мы поставляем электронные компоненты отечественного и импортного производства напрямую от производителей и с крупнейших складов мира.

Благодаря сотрудничеству с мировыми поставщиками мы осуществляем комплексные и плановые поставки широчайшего спектра электронных компонентов.

Собственная эффективная логистика и склад в обеспечивает надежную поставку продукции в точно указанные сроки по всей России.

Мы осуществляем техническую поддержку нашим клиентам и предпродажную проверку качества продукции. На все поставляемые продукты мы предоставляем гарантию .

Осуществляем поставки продукции под контролем ВП МО РФ на предприятия военно-промышленного комплекса России , а также работаем в рамках 275 ФЗ с открытием отдельных счетов в уполномоченном банке. Система менеджмента качества компании соответствует требованиям ГОСТ ISO 9001.

Минимальные сроки поставки, гибкие цены, неограниченный ассортимент и индивидуальный подход к клиентам являются основой для выстраивания долгосрочного и эффективного сотрудничества с предприятиями радиоэлектронной промышленности, предприятиями ВПК и научно-исследовательскими институтами России.

С нами вы становитесь еще успешнее!

### Наши контакты:

**Телефон:** +7 812 627 14 35

**Электронная почта:** [sales@st-electron.ru](mailto:sales@st-electron.ru)

**Адрес:** 198099, Санкт-Петербург,  
Промышленная ул, дом № 19, литера Н,  
помещение 100-Н Офис 331