

Description

The [XR5P920](#) is a single chip solution that converts four channels of analog video to YCbCr digital component video. The power of the XR5P920 lies in its ability to accept a wide range of input formats including the new high-definition (HD) analog standard, HDCVI, as well as the standard-definition (SD) formats of NTSC, PAL and widescreen 960H. The four-output channels of the XR5P920 conform to the SMPTE and ITU-R digital HD standards up to 1080p30 or 720p60 in addition to the digital SD standards. Each video channel offers independent brightness, contrast, sharpness, gain, white-peak control, hue and saturation adjustment.

The XR5P920 effectively decodes video from over 500-m of coaxial cable with the aid of an internal equalizer which compensates for high-frequency signal attenuation. Following equalization, the video from each channel is processed through an analog front end (AFE) that provides clamping, programmable gain amplification and analog-to-digital conversion (ADC). Each video output supports time division multiplexing (TDM) two channels of HD video or up to four channels of SD video. The XR5P920 also has the flexibility to provide a mixed mode output that multiplexes both HD and SD video onto one or all four channels.

Additional features include an I²S interface that allows for audio record and playback, a simple communication protocol enabling two-way control and a 400 kHz I²C interface for CPU or MCU interconnect. Audio is processed with 16-bit pulse code modulation (PCM) that enables up to five channels of high quality audio input.

FEATURES

- Four independent analog video inputs
 - High-definition HDCVI 1080p30/25
 - High-definition HDCVI 720p60/50/30/25
 - Standard-definition NTSC, PAL or 960H
- Four independent digital video 4:2:2 YCbCr outputs
 - HD (BT.1120): 1080p30/25 (SMPTE274)
 - HD (BT.1120): 720p60/50/30/25 (SMPTE296)
 - SD (BT.656): D1 or 960H
 - Each output offers 2X or 4X TDM
- Audio
 - Coaxial or line-in inputs
 - 16-bit precision
 - 16-bit DAC for talkback
 - I²S interface for audio record and playback
- I²C slave interface for external control
- 220-pin 11mm x 11mm LFBGA package

BENEFITS

- HD video over 500m on coax
- Independent HD and SD channel control
- Seamless integration with existing equipment
- Video, audio and control signals over coax

APPLICATIONS

- Affordable HD video surveillance
- High-definition DVR upgrade

Typical Application

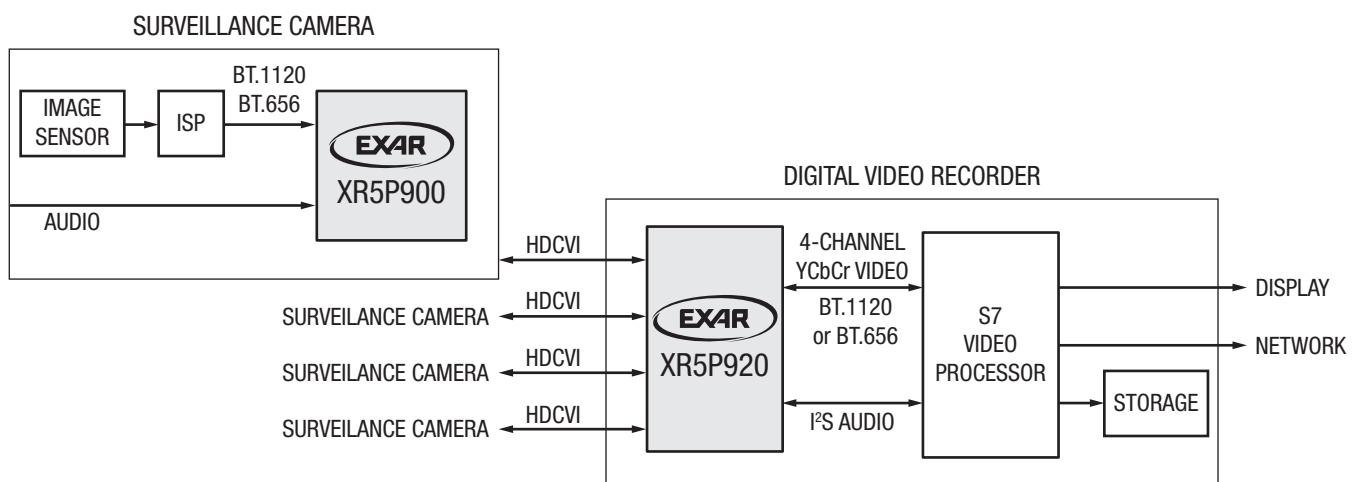

Functional Block Diagram

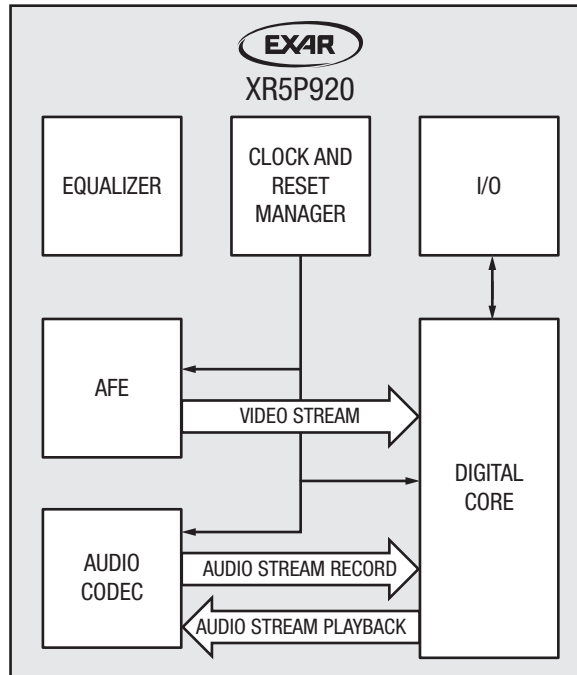

Ordering Information

| Part Number | Operating Temperature Range | Environmental Rating | Package |
|-------------|----------------------------------------------|-----------------------------------------|---------------------------|
| XR5P920-F | 0°C to 70°C | RoHS compliant and Green ⁽¹⁾ | 220-pin 11mm x 11mm LFBGA |
| EVK-XR5R921 | Evaluation Kit, HDCVI PCIe card with XR5P920 | | |

NOTE:
 1. Visit www.exar.com for more information.

Please contact videotechsupport@exar.com to request a complete datasheet.



www.exar.com

48760 Kato Road
 Fremont, CA 94538
 USA

Tel.: +1 (510) 668-7000
 Fax: +1 (510) 668-7001
 Email: videotechsupport@exar.com

Exar Corporation reserves the right to make changes to the products contained in this publication in order to improve design, performance or reliability. Exar Corporation conveys no license under any patent or other right and makes no representation that the circuits are free of patent infringement. While the information in this publication has been carefully checked, no responsibility, however, is assumed for inaccuracies.

Exar Corporation does not recommend the use of any of its products in life support applications where the failure or malfunction of the product can reasonably be expected to cause failure of the life support system or to significantly affect its safety or effectiveness. Products are not authorized for use in such applications unless Exar Corporation receives, in writing, assurances to its satisfaction that: (a) the risk of injury or damage has been minimized; (b) the user assumes all such risks; (c) potential liability of Exar Corporation is adequately protected under the circumstances.

Reproduction, in part or whole, without the prior written consent of Exar Corporation is prohibited. Exar, XR and the XR logo are registered trademarks of Exar Corporation. All other trademarks are the property of their respective owners.



Стандарт Электрон Связь

Мы молодая и активно развивающаяся компания в области поставок электронных компонентов. Мы поставляем электронные компоненты отечественного и импортного производства напрямую от производителей и с крупнейших складов мира.

Благодаря сотрудничеству с мировыми поставщиками мы осуществляем комплексные и плановые поставки широчайшего спектра электронных компонентов.

Собственная эффективная логистика и склад в обеспечивает надежную поставку продукции в точно указанные сроки по всей России.

Мы осуществляем техническую поддержку нашим клиентам и предпродажную проверку качества продукции. На все поставляемые продукты мы предоставляем гарантию .

Осуществляем поставки продукции под контролем ВП МО РФ на предприятия военно-промышленного комплекса России , а также работаем в рамках 275 ФЗ с открытием отдельных счетов в уполномоченном банке. Система менеджмента качества компании соответствует требованиям ГОСТ ISO 9001.

Минимальные сроки поставки, гибкие цены, неограниченный ассортимент и индивидуальный подход к клиентам являются основой для выстраивания долгосрочного и эффективного сотрудничества с предприятиями радиоэлектронной промышленности, предприятиями ВПК и научно-исследовательскими институтами России.

С нами вы становитесь еще успешнее!

Наши контакты:

Телефон: +7 812 627 14 35

Электронная почта: sales@st-electron.ru

Адрес: 198099, Санкт-Петербург,
Промышленная ул, дом № 19, литера Н,
помещение 100-Н Офис 331