

Product Description

The QPF8538 provides a complete integrated solution in a single front end module (FEM) for Wi-Fi 802.11a/n/ac systems. The small form factor and integrated matching minimizes layout area in the application and greatly reduces the number of external components.

Performance is focused on a balance of efficiency to linear power that increases the range and throughput of connections. Control lines are reduced to a two-line control scheme

The QPF8538 integrates a 5GHz power amplifier (PA), single-pole two-throw switch (SP2T) and a low noise amplifier (LNA) with bypass. Integrated filtering includes 2nd and 3rd harmonic as well as 2.4GHz rejection for dual-band dual-concurrent operation. A DC power detector is integrated for application calibration enablement. The device is provided in a 2.3mm x 2.3mm x 0.63mm, 16-pin laminate package.

Functional Block Diagram

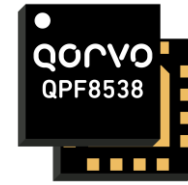
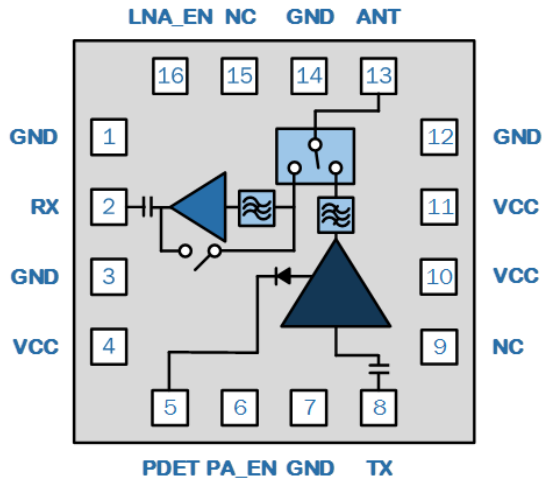

Package: Laminate, 16-pin,
2.3mm x 2.3mm x 0.63mm max

Feature Overview

- P_{OUT} = +17dBm, 802.11ac, VHT80 MCS9 at -35dB Dynamic EVM
- P_{OUT} = +18dBm, 802.11n, HT20/40 MCS7 at -30dB Dynamic EVM
- P_{OUT} = +21dBm, HT20 MCS0 at Spectral Mask Compliance
- 3.3V Operation
- RX Gain = 12.5dB
- Noise Figure = 2.5dB
- Bypass Loss = 5dB
- Input and Output Matched to 50Ω
- Integrated 2.4GHz Rejection Filter

Applications

- Wireless Routers
- Access Points
- Enterprise Client Access Points
- Consumer Premise Equipment
- Wireless Adapters
- Internet of Things

Ordering Information

PART NUMBER	DESCRIPTION
QPF8538SB	Sample bag with 5 pieces
QPF8538SQ	Sample bag with 25 pieces
QPF8538SR	7" Reel with 100 pieces
QPF8538TR7	7" Reel with 2500 pieces
QPF8538PCK401	Assembled Evaluation Board

Absolute Maximum Ratings

PARAMETER	RATING	UNIT
DC Supply Voltage (No RF Applied)	-0.5 to +6	V _{DC}
Control Voltage	-0.5 to +5	V _{DC}
DC Supply Current	500	mA
Storage Temperature	-40 to +150	°C
Maximum TX Input Power into 50Ω Load for 11a/n/ac (No Damage)	+10	dBm
Maximum RX Input Power - LNA On Mode (No Damage)	+5	dBm
Maximum RX Input Power – Bypass Mode (No Damage)	+25	dBm

Exceeding any one or a combination of the Absolute Maximum Rating conditions may cause permanent damage to the device. Extended application of Absolute Maximum Rating conditions to the device may reduce device reliability. Specified typical performance or functional operation of the device under Absolute Maximum Rating conditions is not implied.

Nominal Operating Parameters

PARAMETER	MIN	TYP	MAX	UNIT	CONDITION
COMPLIANCE					802.11A, 802.11N, 802.11AC
Operating Frequency	5.150		5.925	GHz	
Extended Operating Frequency	4.9		5.925	GHz	
Operating Temperature	-40		+85	°C	
Power Supply V _{CC}	3.0	3.3	4.2	V	
Control Voltage-High	2.8	2.95	V _{CC}	V	
Control Voltage-Low		0	0.2	V	

TRANSMIT (TX-ANT) HIGH POWER MODE					V_{CC}=3.3V, T=+25°C, f=5.15-5.925GHz, PA_EN=High, LNA_EN=Low; Unless otherwise noted
11ac VHT80 Output Power		17		dBm	MCS9
Dynamic EVM		1.5	1.8	%	
		-36	-35	dB	
11n HT20/40 Output Power		18		dBm	MCS7
Dynamic EVM		2.5	3	%	
		-32	-30	dB	
Margin to 802.11ac 80MHz Spectral Mask		3	0	dBc	P _{OUT} = +19dBm, MCS0
Margin to 802.11n 20MHz Spectral Mask		3	0	dBc	P _{OUT} = +20.5dBm, MCS0
Margin to 802.11a Spectral Mask		3	0	dBc	P _{OUT} = +21dBm, OFDM 6MBps
Large Signal Gain	26	28		dB	
	24	25.5		dB	T = +85°C
Gain Flatness	-0.25		+0.25	dB	Across any 80MHz channel

PARAMETER	MIN	TYP	MAX	UNIT	CONDITION
Out of Band Gain			-41	dB	$f = 800\text{-}900\text{MHz}$
			-39	dB	$f = 1800\text{-}2100\text{MHz}$
			-35	dB	$f = 2300\text{-}2400\text{MHz}$
			-31	dB	$f = 2490\text{-}2690\text{MHz}$
			6	dB	$f = 3400\text{-}3800\text{MHz}$
			20	dB	$f = 3800\text{-}4400\text{MHz}$
			24	dB	$f = 7250\text{-}7700\text{MHz}$
Quiescent Current		160		mA	RF=Off
Operating Current		210		mA	$P_{OUT} = 17\text{dBm}$
		215		mA	$P_{OUT} = 18\text{dBm}$
		270		mA	$P_{OUT} = 21\text{dBm}$
TX Port Return Loss	7	10		dB	
ANT Port Return Loss	10	15		dB	
2 nd Harmonics		-30	-25	dBm/MHz	$P_{OUT} = 21\text{dBm}$ 802.11a 6Mbps
3 rd Harmonics		-30	-25	dBm/MHz	$P_{OUT} = 21\text{dBm}$ 802.11a 6Mbps
ANT-RX Isolation	25	30		dB	
Power Detector Voltage		0.23		mV	RF Off
		0.45		mV	$P_{OUT} = +17\text{dBm}@5775\text{MHz}$
		0.62		mV	$P_{OUT} = +21\text{dBm}@5775\text{MHz}$

TRANSMIT (TX-ANT) LOW POWER MODE					$V_{CC}=3.3\text{V}$, $T=+25^{\circ}\text{C}$, $f=5.15\text{-}5.925\text{GHz}$, PA_EN & LNA_EN=High; Unless otherwise noted
11ac VHT80 Output Power		14		dBm	MCS9
Dynamic EVM		1.5	1.8	%	
		-36	-35	dB	
Large Signal Gain	25	27		dB	
	23	24.5		dB	$T = +85^{\circ}\text{C}$
Gain Flatness	-0.25		+0.25	dB	Across any 80MHz channel
Operating Current		160		mA	$P_{OUT} = 14\text{dBm}$
TX Port Return Loss	7	10		dB	
ANT Port Return Loss	10	20		dB	

RECEIVE (ANT-RX) LNA ON MODE					$V_{CC}=3.3\text{V}$, $T=+25^{\circ}\text{C}$, $f=5.15\text{-}5.925\text{GHz}$, PA_EN=Low, LNA_EN=High; Unless otherwise noted
Gain		12.5		dB	
		11		dB	$T = +85^{\circ}\text{C}$

PARAMETER	MIN	TYP	MAX	UNIT	CONDITION
Out of Band Gain			-45	dB	$f = 2400\text{-}2480\text{MHz}$
			-5	dB	$f = 2480\text{-}3800\text{MHz}$
Noise Figure		2.5	3	dB	
RX Operating Current		10	15	mA	
RX Port Return Loss		7		dB	
ANT Port Return Loss		7		dB	
Input P ^{1dB}		-4		dBm	
Input IP3		4		dB	Two-tone inband

RECEIVE (ANT-RX) BYPASS MODE	MIN	TYP	MAX	UNIT	CONDITION
					$V_{CC}=3.3V, T=+25^{\circ}C, f=5.15\text{-}5.925\text{GHz}, PA_EN \& LNA_EN=Low$; Unless otherwise noted
Bypass Loss	3.5	5	6.5	dB	
RX Port Return Loss		8		dB	
ANT Port Return Loss		20		dB	
Input P ^{1dB}		+15		dBm	
Input IP3		30		dB	Two-tone inband

GENERAL SPECIFICATIONS	MIN	TYP	MAX	UNIT	CONDITION
FEM Leakage Current		5	10	μA	
PA_EN Control Current		250		μA	
LNA_EN Control Current		80		μA	
PA Turn-On Time		200	500	nS	10% \leftrightarrow 90%; Referencing from control voltage to RF power
LNA Turn-On Time		200	500	nS	
PA Stability			22	dBm	Unconditional into 4:1 VSWR; No spurs above -50dBm/MHz max

Switch Control Logic Truth Table

OPERATING MODE	PA_EN	LNA_EN
802.11a/n/ac TX High Power	High	Low
802.11a/n/ac TX Low Power	High	High
802.11a/n/ac RX Gain	Low	High
802.11a/n/ac RX Bypass	Low	Low
Standby	Low	Low

Evaluation Board Schematic

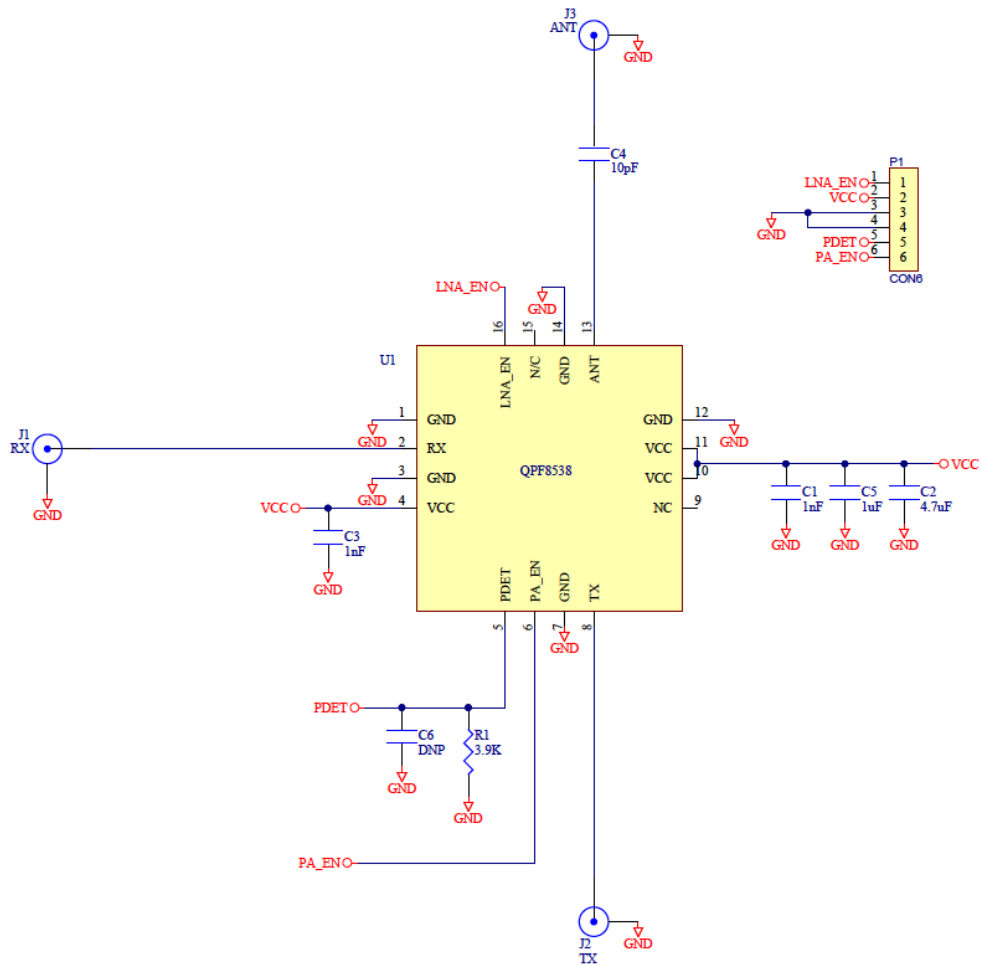

Pin Out

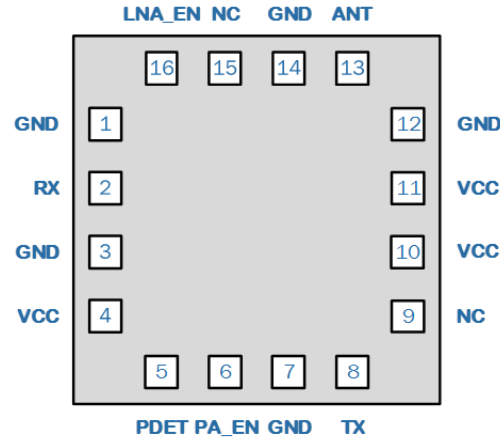

Pin Names and Descriptions

PIN	NAME	DESCRIPTION
1	GND	Ground connection. This pin is not connected internally.
2	RX	RF output port for the LNA. This port is matched to 50Ω and DC blocked internally.
3	GND	Ground connection. This pin is not connected internally.
4	VCC	Supply voltage for the LNA and PA Regulator. See applications schematic for biasing and bypassing components.
5	PDET	Power Detector voltage for the TX path. May need external series R/shunt C to adjust voltage level and to filter RF noise.
6	PA_EN	Control voltage. See Switch Control Logic Truth Table for proper voltage settings.
7	GND	Ground connection. This pin is not connected internally.
8	TX	RF input port for the PA. This port is matched to 50Ω and DC blocked internally.
9	NC	No connect. This pin is not connected internally and can be left floating or connected to ground.
10	VCC	Supply voltage for the 1 st and 2 nd stages of the PA. See applications schematic for biasing and bypassing components.
11	VCC	Supply voltage for the final stage of the PA. See applications schematic for biasing and bypassing components.
12	GND	Ground connection. This pin is not connected internally.
13	ANT	RF bi-directional antenna port matched to 50Ω. An external DC block is required.
14	GND	Ground connection. This pin is not connected internally.
15	NC	No connect. This pin is not connected internally and can be left floating or connected to ground.
16	LNA_EN	Control voltage. See Switch Control Logic Truth Table for proper voltage settings.
Pkg Base	GND	Ground connection. The backside of the package should be connected to the ground plane through a short path, i.e., PCB vias under the device are recommended.

Package Outline (Dimensions in millimeters)

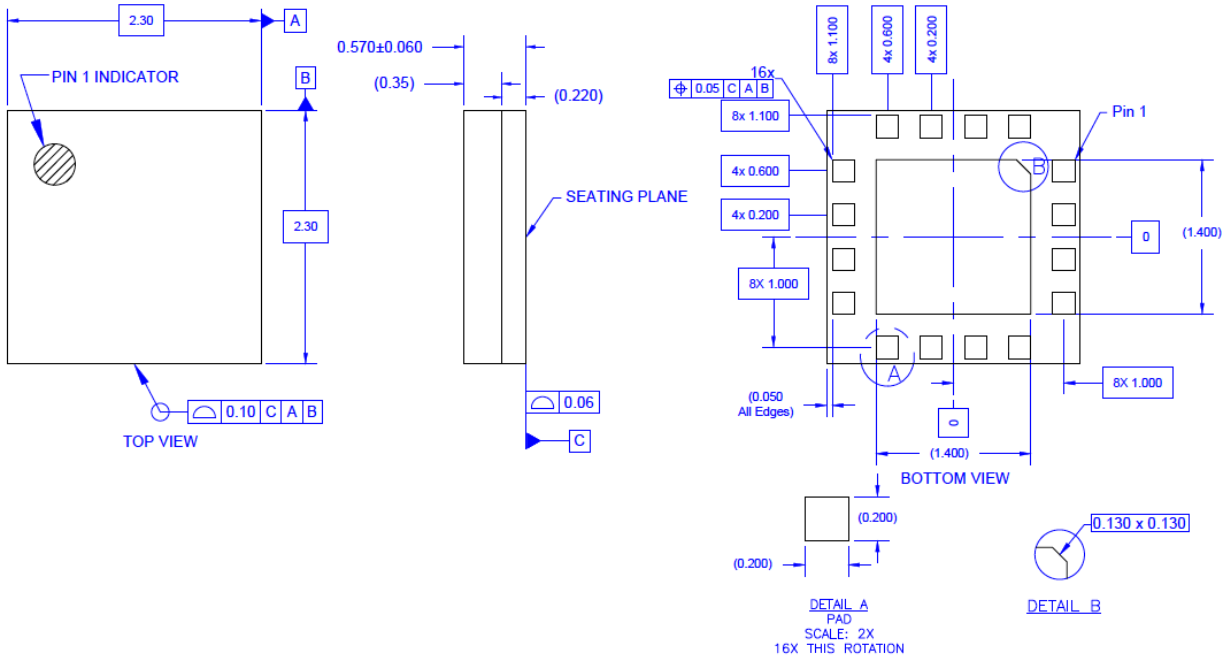

PCB Mounting Pattern (Dimensions in millimeters)

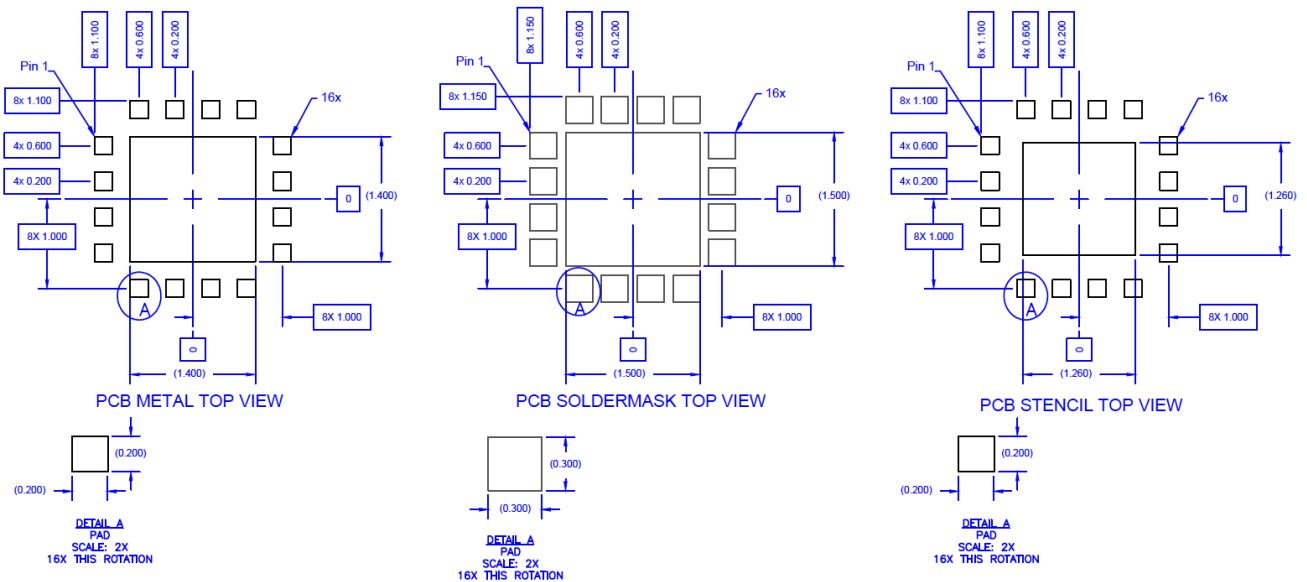

Product Compliance Information



Caution! ESD-Sensitive Device

ESD Sensitivity Ratings

ESD Rating: Class 1B
Voltage: Passes $\geq 500V$ to $< 1000V$
Test: Human Body Model (HBM)
Standard: JEDEC Standard JESD22-A114

ESD Rating: Class C3
Voltage: Passes $\geq 1000V$
Test: Charged Device Model (CDM)
Standard: JEDEC Standard JESD22-C101

MSL Rating

MSL Rating: Level 3
Test: $260^{\circ}C$ convection reflow
Standard: JEDEC Standard IPC/JEDEC J-STD-020

Solderability

Compatible with both lead-free ($260^{\circ}C$ max. reflow temperature) and tin/lead ($245^{\circ}C$ max. reflow temperature) soldering processes.

RoHS Compliance

This part is compliant with EU 2002/95/EC RoHS directive (Restrictions on the Use of Certain Hazardous Substances in Electrical and Electronic Equipment).

- Lead Free
- Halogen Free (Chlorine, Bromine)
- Antimony Free
- TBBP-A (C₁₅H₁₂Br₄O₂) Free
- PFOS Free
- SVHC Free

Contact Information

For the latest specifications, additional product information, worldwide sales and distribution locations, and information about Qorvo:

Web: www.qorvo.com
Tel: +1-844-890-8163
Email: customer.support@qorvo.com

For information about Qorvo:

Web: www.qorvo.com



Стандарт Электрон Связь

Мы молодая и активно развивающаяся компания в области поставок электронных компонентов. Мы поставляем электронные компоненты отечественного и импортного производства напрямую от производителей и с крупнейших складов мира.

Благодаря сотрудничеству с мировыми поставщиками мы осуществляем комплексные и плановые поставки широчайшего спектра электронных компонентов.

Собственная эффективная логистика и склад в обеспечивает надежную поставку продукции в точно указанные сроки по всей России.

Мы осуществляем техническую поддержку нашим клиентам и предпродажную проверку качества продукции. На все поставляемые продукты мы предоставляем гарантию .

Осуществляем поставки продукции под контролем ВП МО РФ на предприятия военно-промышленного комплекса России , а также работаем в рамках 275 ФЗ с открытием отдельных счетов в уполномоченном банке. Система менеджмента качества компании соответствует требованиям ГОСТ ISO 9001.

Минимальные сроки поставки, гибкие цены, неограниченный ассортимент и индивидуальный подход к клиентам являются основой для выстраивания долгосрочного и эффективного сотрудничества с предприятиями радиоэлектронной промышленности, предприятиями ВПК и научно-исследовательскими институтами России.

С нами вы становитесь еще успешнее!

Наши контакты:

Телефон: +7 812 627 14 35

Электронная почта: sales@st-electron.ru

Адрес: 198099, Санкт-Петербург,
Промышленная ул, дом № 19, литера Н,
помещение 100-Н Офис 331