



MCP212X
Developer's Daughter Board
User's Guide

Note the following details of the code protection feature on Microchip devices:

- Microchip products meet the specification contained in their particular Microchip Data Sheet.
- Microchip believes that its family of products is one of the most secure families of its kind on the market today, when used in the intended manner and under normal conditions.
- There are dishonest and possibly illegal methods used to breach the code protection feature. All of these methods, to our knowledge, require using the Microchip products in a manner outside the operating specifications contained in Microchip's Data Sheets. Most likely, the person doing so is engaged in theft of intellectual property.
- Microchip is willing to work with the customer who is concerned about the integrity of their code.
- Neither Microchip nor any other semiconductor manufacturer can guarantee the security of their code. Code protection does not mean that we are guaranteeing the product as "unbreakable."

Code protection is constantly evolving. We at Microchip are committed to continuously improving the code protection features of our products. Attempts to break Microchip's code protection feature may be a violation of the Digital Millennium Copyright Act. If such acts allow unauthorized access to your software or other copyrighted work, you may have a right to sue for relief under that Act.

Information contained in this publication regarding device applications and the like is provided only for your convenience and may be superseded by updates. It is your responsibility to ensure that your application meets with your specifications. MICROCHIP MAKES NO REPRESENTATIONS OR WARRANTIES OF ANY KIND WHETHER EXPRESS OR IMPLIED, WRITTEN OR ORAL, STATUTORY OR OTHERWISE, RELATED TO THE INFORMATION, INCLUDING BUT NOT LIMITED TO ITS CONDITION, QUALITY, PERFORMANCE, MERCHANTABILITY OR FITNESS FOR PURPOSE. Microchip disclaims all liability arising from this information and its use. Use of Microchip's products as critical components in life support systems is not authorized except with express written approval by Microchip. No licenses are conveyed, implicitly or otherwise, under any Microchip intellectual property rights.

Trademarks

The Microchip name and logo, the Microchip logo, Accuron, dsPIC, KEELOQ, microID, MPLAB, PIC, PICmicro, PICSTART, PRO MATE, PowerSmart, rfPIC, and SmartShunt are registered trademarks of Microchip Technology Incorporated in the U.S.A. and other countries.

AmpLab, FilterLab, Migratable Memory, MXDEV, MXLAB, PICMASTER, SEEVAL, SmartSensor and The Embedded Control Solutions Company are registered trademarks of Microchip Technology Incorporated in the U.S.A.

Analog-for-the-Digital Age, Application Maestro, dsPICDEM, dsPICDEM.net, dsPICworks, ECAN, ECONOMONITOR, FanSense, FlexROM, fuzzyLAB, In-Circuit Serial Programming, ICSP, ICEPIC, Linear Active Thermistor, MPASM, MPLIB, MPLINK, MPSIM, PICKit, PICDEM, PICDEM.net, PICLAB, PICTail, PowerCal, PowerInfo, PowerMate, PowerTool, rFLAB, rfPICDEM, Select Mode, Smart Serial, SmartTel, Total Endurance and WiperLock are trademarks of Microchip Technology Incorporated in the U.S.A. and other countries.

SQTP is a service mark of Microchip Technology Incorporated in the U.S.A.

All other trademarks mentioned herein are property of their respective companies.

© 2005, Microchip Technology Incorporated, Printed in the U.S.A., All Rights Reserved.

 Printed on recycled paper.

**QUALITY MANAGEMENT SYSTEM
CERTIFIED BY DNV
== ISO/TS 16949:2002 ==**

Microchip received ISO/TS-16949:2002 quality system certification for its worldwide headquarters, design and wafer fabrication facilities in Chandler and Tempe, Arizona and Mountain View, California in October 2003. The Company's quality system processes and procedures are for its PICmicro® 8-bit MCUs, KEELOQ® code hopping devices, Serial EEPROMs, microperipherals, nonvolatile memory and analog products. In addition, Microchip's quality system for the design and manufacture of development systems is ISO 9001:2000 certified.



MCP212X DEVELOPER'S DAUGHTER BOARD USER'S GUIDE

Table of Contents

Preface	1
Chapter 1. Product Overview	7
1.1 Introduction	7
1.2 What is the MCP212X Daughter Board?	7
1.3 What the MCP212X Daughter Board Kit Includes	8
Chapter 2. Installation and Operation	9
2.1 Introduction	9
2.2 Features	10
2.3 Getting Started	11
2.4 Making a Demo System	16
2.5 MCP212X Daughter Board Description	18
Appendix A. Schematic and Layouts	21
A.1 Introduction	21
A.2 Schematics and PCB Layout	21
Appendix B. Bill of Materials (BOM)	27
Appendix C. Board Testing	29
C.1 What is Tested	29
C.2 What is NOT Tested	29
Appendix D. Using the MCP212X Daughter Board with the PICDEM™ HPC Explorer Demo Board	31
D.1 Demonstration using two PICDEM HPC Explorer Demo Boards	31
Appendix E. Using the MCP212X Daughter Board with the PICDEM™ FS USB Demo Board	37
E.1 Demonstration with the PICDEM FS USB Demo Board	37
Appendix F. Configuring the HyperTerminal® Program	41
F.1 Configuring the HyperTerminal Program	41
Worldwide Sales and Service	46

MCP212X Developer's Daughter Board User's Guide

NOTES:



MCP212X DEVELOPER'S DAUGHTER BOARD USER'S GUIDE

Preface

NOTICE TO CUSTOMERS

All documentation becomes dated, and this manual is no exception. Microchip tools and documentation are constantly evolving to meet customer needs, so some actual dialogs and/or tool descriptions may differ from those in this document. Please refer to our web site (www.microchip.com) to obtain the latest documentation available.

Documents are identified with a "DS" number. This number is located on the bottom of each page, in front of the page number. The numbering convention for the DS number is "DSXXXXXA", where "XXXXX" is the document number and "A" is the revision level of the document.

INTRODUCTION

This chapter contains general information that will be useful to know before using the MCP212X Developer's Daughter Board. Items discussed in this chapter include:

- Document Layout
- Conventions Used in this Guide
- Recommended Reading
- The Microchip Web Site
- Customer Support
- Document Revision History

MCP212X Developer's Daughter Board User's Guide

DOCUMENT LAYOUT

This document describes how to use the MCP212X Developer's Daughter Board. The manual layout is as follows:

- **Chapter 1. "Product Overview"** – Important information about the MCP212X Developer's Daughter Board.
- **Chapter 2. "Installation and Operation"** – Includes a detailed description of each function, as well as instructions on how to get started with this daughter board.
- **Appendix A. "Schematic and Layouts"** – Shows the schematic and layout diagrams for the MCP212X Developer's Daughter Board.
- **Appendix B. "Bill of Materials (BOM)"** – Lists the parts used to build the MCP212X Developer's Daughter Board.
- **Appendix C. "Board Testing"** – Discusses the testing of the MCP212X Developer's Daughter Board in several configurations.
- **Appendix D. "Using the MCP212X Developer's Daughter Board with the PICDEM™ HPC Explorer Demo Board"** – Shows how the MCP212X Developer's Daughter Board can be demonstrated using the PICDEM™ HPC Explorer Demo Board.
- **Appendix E. "Using the MCP212X Developer's Daughter Board with the PICDEM™ FS USB Demo Board"** – Shows how the MCP212X Developer's Daughter Board can be demonstrated using the PICDEM™ FS USB Demo Board.
- **Appendix F. "Configuring the HyperTerminal® Program"** – Shows the configuration of the HyperTerminal program used to demonstrate the MCP212X Developer's Daughter Board system.

CONVENTIONS USED IN THIS GUIDE

This manual uses the following documentation conventions:

DOCUMENTATION CONVENTIONS

Description	Represents	Examples
Arial font:		
Italic characters	Referenced books	<i>MPLAB[®] IDE User's Guide</i>
	Emphasized text	...is the <i>only</i> compiler...
Initial caps	A window	the Output window
	A dialog	the Settings dialog
	A menu selection	select Enable Programmer
Quotes	A field name in a window or dialog	"Save project before build"
Underlined, italic text with right angle bracket	A menu path	<u><i>File>Save</i></u>
Bold characters	A dialog button	Click OK
	A tab	Click the Power tab
Text in angle brackets < >	A key on the keyboard	Press <Enter>, <F1>
Courier New font:		
Plain Courier New	Sample source code	<code>#define START</code>
	Filenames	<code>autoexec.bat</code>
	File paths	<code>c:\mcc18\h</code>
	Keywords	<code>_asm, _endasm, static</code>
	Command-line options	<code>-Opa+, -Opa-</code>
	Bit values	<code>0, 1</code>
	Constants	<code>0xFF, 'A'</code>
Italic Courier	A variable argument	<i>file.o</i> , where <i>file</i> can be any valid filename
Square brackets []	Optional arguments	<code>mcc18 [options] file [options]</code>
Curly brackets and pipe character: { }	Choice of mutually exclusive arguments; an OR selection	<code>errorlevel {0 1}</code>
Ellipses...	Replaces repeated text	<code>var_name [, var_name...]</code>
	Represents code supplied by user	<code>void main (void) { ... }</code>

MCP212X Developer's Daughter Board User's Guide

RECOMMENDED READING

This user's guide describes how to use the MCP212X Developer's Daughter Board. The following Microchip documents are available and recommended as supplemental reference resources.

MCP2122 Data Sheet (DS21894)

This data sheet provides detailed information regarding the MCP2122 device.

MCP2120 Data Sheet (DS21618)

This data sheet provides detailed information regarding the MCP2120 device.

AN946, "Interfacing the MCP2122 to Host Controller" (DS00946)

This application note discusses the interface between a Host Controller and the MCP2122 device.

TB073, "Selecting a MCP21XX Device for IrDA® Applications" (DS91073)

This technical brief discusses the selection of the MCP21XX devices for IrDA® standard applications.

AN756, "Using the MCP2120 for Infrared Communications" (DS00756)

This application note discusses the encoding/decoding function of the MCP2120 as specified in the physical layer component of the IrDA® standard.

AN923, "Using the MCP2120 Developer's Board for "IR Sniffing" (DS00923)

This application note discusses how one can use the MCP2120 Developer's Board for "IR Sniffing". This technique can assist in the debugging of an IrDA® standard system.

The following documents may be useful, depending on which PICDEM™ demo board you are using with the MCP212X Developer's Daughter Board.

PIC18F8722 Family Data Sheet (DS39646)

This data sheet provides detailed information regarding the PIC18F8722 device. This device is used on the PICDEM™ HPC Explorer Demo Board (DM183022).

PICDEM™ 2 Plus Demo Board User's Guide (DS51275)

This user's guide provides detailed information regarding the PICDEM™ 2 Plus Board (DM163022).

PIC16F87XA Family Data Sheet (DS39582)

This data sheet provides detailed information regarding the PIC16F87XA device. This device is used on the PICDEM™ 2 Plus Demo Board (DM163022).

PICDEM™ FS USB Demonstration Board User's Guide (DS51526)

This user's guide provides detailed information regarding the PICDEM™ Full-Speed USB Demo Board (DM163025).

PIC18F4550 Data Sheet (DS39632)

This data sheet provides detailed information regarding the PIC18F4550 device. This device is used on the PICDEM™ Full-Speed USB Demo Board (DM163025).

PICDEM™ LCD Demo Board User's Guide (DS51536)

This user's guide provides detailed information regarding the PICDEM™ LCD Demo Board (DM163028).

PIC18F8490 Data Sheet (DS39629)

This data sheet provides detailed information regarding the PIC18F8490 device. This device is used on the PICDEM™ LCD Demo Board (DM163028).

THE MICROCHIP WEB SITE

Microchip provides online support via our web site at www.microchip.com. This web site is used as a means to make files and information easily available to customers. Accessible by using your favorite Internet browser, the web site contains the following information:

- **Product Support** – Data sheets and errata, application notes and sample programs, design resources, user's guides and hardware support documents, latest software releases and archived software
- **General Technical Support** – Frequently Asked Questions (FAQs), technical support requests, online discussion groups, Microchip consultant program member listing
- **Business of Microchip** – Product selector and ordering guides, latest Microchip press releases, listing of seminars and events, listings of Microchip sales offices, distributors and factory representatives

CUSTOMER SUPPORT

Users of Microchip products can receive assistance through several channels:

- Distributor or Representative
- Local Sales Office
- Field Application Engineer (FAE)
- Technical Support
- Development Systems Information Line

Customers should contact their distributor, representative or field application engineer (FAE) for support. Local sales offices are also available to help customers. A listing of sales offices and locations is included in the back of this document.

Technical support is available through the web site at: <http://support.microchip.com>

DOCUMENT REVISION HISTORY

Revision A (August 2005)

- Initial release of this document.

MCP212X Developer's Daughter Board User's Guide

NOTES:

Chapter 1. Product Overview

1.1 INTRODUCTION

This chapter provides an overview of the MCP212X Developer's Daughter Board and covers the following topics:

- What is the MCP212X Developer's Daughter Board?
- What the MCP212X Developer's Daughter Board kit includes

1.2 WHAT IS THE MCP212X DEVELOPER'S DAUGHTER BOARD?

The MCP212X Developer's Daughter Board is used to evaluate and demonstrate the MCP2122 or MCP2120 IrDA® Standard Encoder/Decoder device. This allows the system designer to implement a low-cost, wireless IR port in any application providing support for IrDA standard bit encoding/decoding.

The MCP212X Developer's Daughter Board is designed to interface to several of the "new" low-cost PICmicro® microcontroller-based demonstration (demo) boards, or to be interfaced into your application. Multiple header interfaces are available that allow support for the many different PICDEM™ Demo Boards, as well as being easily jumpered into systems for development purposes. Table 1-1 shows some of the PICDEM demo boards that are supported.

Depending on the features of the PICmicro Microcontroller Unit (MCU) and the selected demo board, the MCP2122 TX and RX signals can either be connected (jumpered) directly to the RS-232 line driver or to the PICmicro MCU's RX and TX signals. The PICmicro MCU could process that data and then send it out of the UART.

TABLE 1-1: PICDEM™ DEMO BOARD SUPPORT (1)

Name	Order Number	Literature #	Host Controller (PICmicro® MCU) Supported	Header(s) Used	TX/RX Signals to (3)	
					Host Controller	RS-232
PICDEM™ HPC Explorer Board (2)	DM183022	DS51540	PIC18F8722	J1, J2	Y	Y
PICDEM™ LCD	DM163028	DS51536	PIC18F8490	J1, J2	Y	Y
PICDEM™ Full-Speed USB	DM163025	DS51526	PIC18F4550	J3	Y	N/A
PICDEM™ 2 Plus	DM163022	DS51275	PIC16F877, PIC18F452	J3	Y	N
User Embedded System	N/A	—	—	HD1	Y	—

- Note 1:** Other boards may also be supported. Please refer to the MCP212X Developer's Daughter Board and desired PICDEM™ Demo Board documentation to determine if the boards you are using are supported.
- 2:** For proper orientation of the daughter board to the PICDEM™ demo board, Revision 5 of the PICDEM™ HPC Explorer Board is recommended. Revision 4 will function, but the direction of the optical transceiver will be facing the same side as the serial port connector.
- 3:** The MCP212X Developer's Daughter Board allows the MCP212X TX and RX signals to be routed to different header connections. This may allow the system to support multiple configurations, such as being either connected to the PICmicro® MCU USART or to the RS-232 driver (allows the MCP212X to directly communicate via the DB-9 connector).

MCP212X Developer's Daughter Board User's Guide

1.3 WHAT THE MCP212X DEVELOPER'S DAUGHTER BOARD KIT INCLUDES

This MCP212X Developer's Daughter Board Kit includes:

- The MCP212X Developer's Daughter Board (with MCP2122 installed)
- A MCP2120 sample device
- MCP212X Developer's Daughter Board User's Guide (DS51571) (on CD-ROM)
- PICDEM™ HPC Explorer Board firmware (on CD-ROM)
- PICDEM™ USB Board firmware (on CD-ROM)



MCP212X DEVELOPER'S DAUGHTER BOARD USER'S GUIDE

Chapter 2. Installation and Operation

2.1 INTRODUCTION

This chapter discusses the operation of the MCP212X Developer's Daughter Board and how it can be used in conjunction with some of Microchip's low-cost PICDEM™ Demo Boards or easily connected to your system.

When the MCP212X Developer's Daughter Board is used in conjunction with one of the low-cost PICDEM™ Demo Boards, it demonstrates the implementation of an embedded system with an IrDA® standard physical layer interface (encoder/decoder). A second encoder/decoder system is required to demonstrate system operation.

The Host UART interface includes only the TX and RX signals. A discussion of the Host UART interface is given in the following application note:

- AN946, "Interfacing the MCP2122 to the Host Controller" (DS00946)

MCP212X Developer's Daughter Board User's Guide

2.2 FEATURES

The MCP212X Developer's Daughter Board has the following features:

- Dual Header to connect to:
 - PICDEM™ HPC Explorer Demo Board
 - PICDEM™ LCD Demo Board
- Header to connect to:
 - PICDEM™ Full-Speed USB Demo Board
 - PICDEM™ 2 Plus Demo Board
- Header to easily connect to the user's embedded system
- Installed optical transceiver circuit using:
 - Vishay® TFDU 4300
- Footprint for optional optical transceiver circuits using:
 - Vishay TFDU 4100
 - Agilent® HSDL 3000
- Jumpers to select connection point (header) for the following signals:
 - TX
 - RX
 - 16XCLK
- Jumpers to “swap” TX and RX so that the MCP2120 can directly communicate over the PICDEM™ HPC Explorer Board's DB-9 connector
- Jumpers which can be used by the PICDEM demo board firmware program to determine the mode of operation
- 8-pin DIP socket for the installation of the MCP2122
- 14-pin DIP socket for the installation of the MCP2120
- MCP2120's crystal is socketed to allow ease of crystal selection

TABLE 2-1: PICDEM™ DEMO BOARD SUPPORT

PICmicro® MCU Demo Board Name	Part #	PICmicro® MCU	MCU Interface to PC	MCP2122 RX/TX direct access to DB9	User's Guide Lit. #	Comment
PICDEM™ HPC Explorer	DM183022	PIC18F8722	UART	Yes	DS51540	MCU firmware could support: <ul style="list-style-type: none"> • MCP2122 → MCU • MCP2122 → PC (UART) • MCP2122 → MCU → PC (UART)
PICDEM™ LCD	DM163028	PIC18F8490	UART	Yes	DS51536	MCU firmware could support: <ul style="list-style-type: none"> • MCP2122 → MCU • MCP2122 → PC (UART) • MCP2122 → MCU → PC (UART) DB-9 does not have CTS signal
PICDEM™ Full-Speed USB	DM163025	PIC18F4550	USB	—	DS51526	MCU firmware could support: <ul style="list-style-type: none"> • MCP2122 → MCU • MCP2122 → MCU → PC (USB)
PICDEM™ 2 Plus	DM163022	PIC16F877/ PIC18F452	UART	—	DS51275	MCU firmware could support: <ul style="list-style-type: none"> • MCP2122 → MCU

2.3 GETTING STARTED

This section presents an overview of the following system blocks:

- The MCP212X Developer's Daughter Board Hardware
- The MCP212X Developer's Daughter Board Firmware

2.3.1 The MCP212X Developer's Daughter Board Hardware Overview

The major components for the MCP212X Developer's Daughter Board are:

1. MCP2122 device (U4)
2. MCP2120 device socket (U1)
3. Optical transceiver (U5 – Vishay TFDU 4300)
4. Headers H1 and H2
5. Header H3
6. Header HD1
7. Jumpers to route the TX, RX and 16XCLK signals
8. Jumpers to select the baud rate and mode
9. Footprint for two different optional optical transceiver circuits (Vishay TFDU 4100 and Agilent HSDL 3000)
10. MCP2120 crystal (Y2)

The MCP212X Developer's Daughter Board is assembled and tested to allow for the evaluation and demonstration of the MCP2122 or MCP2120 features. A schematic of the circuit, as well as the corresponding PCB layout, is shown in **Appendix A. "Schematic and Layouts"**. **Appendix B. "Bill of Materials (BOM)"** shows two tables; the first is the components that are installed, while the second lists the optional components that are not installed.

The component layout floor plan is shown in Figure 2-1.

2.3.2 Jumper Settings

Figure 2-2 shows the component layout for the MCP212X Developer's Daughter Board and the operation of the JMP1/JP6, JMP2 and JMP3/JP7 jumpers. These jumpers determine the connections between the MCP2120's RX, TX and 16XCLK signals, as well as the header's RX, TX and 16XCLK signals.

FIGURE 2-2: JMP1/JP6, JMP2 AND JMP3/JP7 CONFIGURATIONS

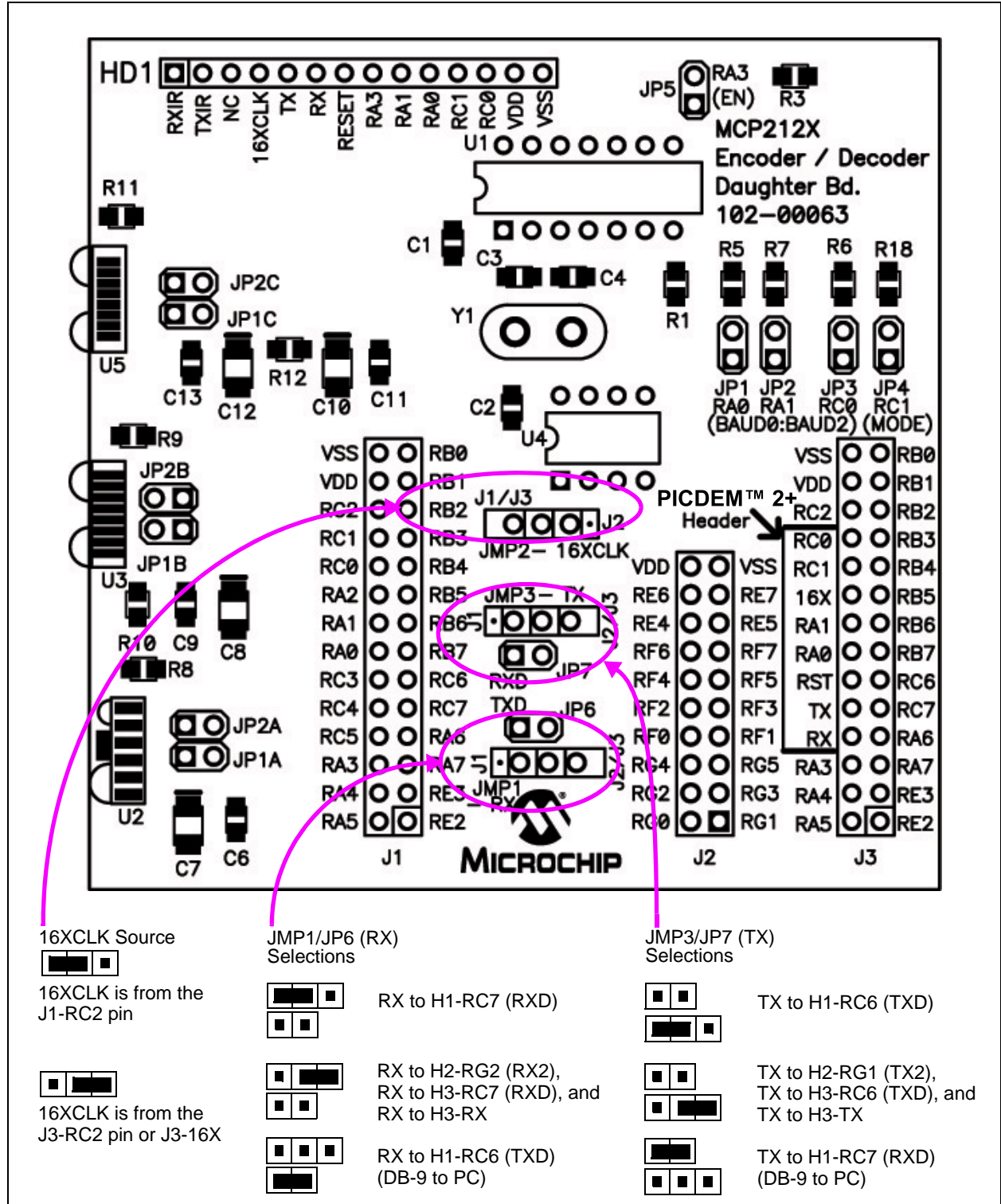

MCP212X Developer's Daughter Board User's Guide

Figure 2-3 shows the component layout for the MCP212X Developer's Daughter Board and the operation of the JP1, JP2, JP3 and JP4 jumpers. When the jumper is open, the signal is pulled high. When the jumper is shorted, the signal is pulled to ground. JP1 is connected to the header's RA0 signal, JP2 is connected to the header's RA1 signal, JP3 is connected to the header's RC0 signal and JP4 is connected to the header's RC1 signal. These signals are also connected to the MCP2120's BAUD and MODE pins.

FIGURE 2-3: JP1, JP2, JP3 AND JP4 CONFIGURATIONS

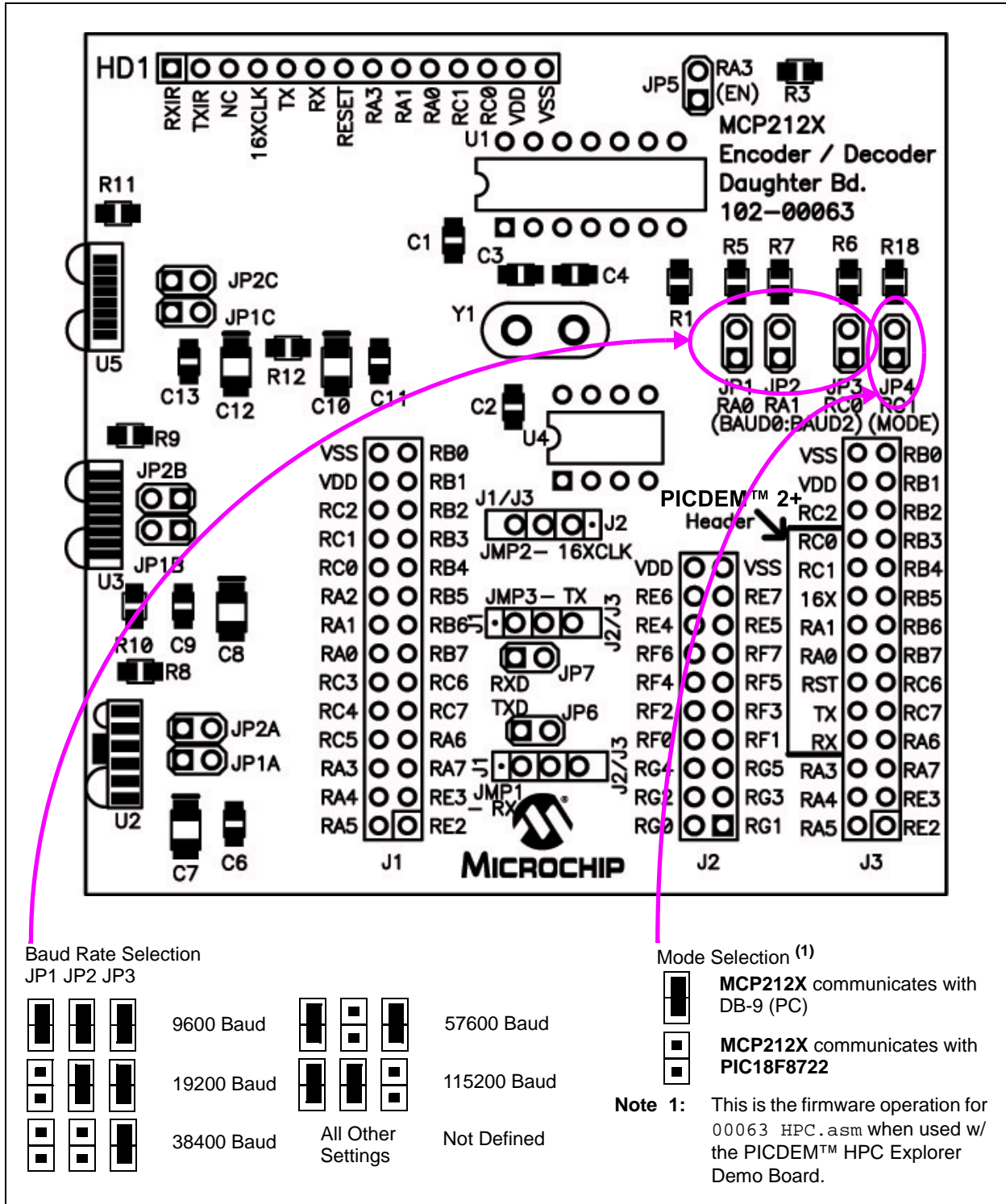

Installation and Operation

A description of the MCP212X Developer's Daughter Board jumpers is given in Table 2-2.

TABLE 2-2: JUMPER DESCRIPTIONS AND SETTINGS

Jumper #	Description	Comment
JP1A:JP2A	To connect TXIR/RXIR of MCP2122 to TXD/RXD of U5 (HSDL 3000) S = TXIR/RXIR connected to TXD/RXD O = TXIR/RXIR Not connected to TXD/RXD	By default not installed.
JP1B:JP2B	To connect TXIR/RXIR of MCP2122 to TXD/RXD of U5 (TFDU 4100) S = TXIR/RXIR connected to TXD/RXD O = TXIR/RXIR Not connected to TXD/RXD	By default not installed.
JP1C:JP2C	To connect TXIR/RXIR of MCP2122 to TXD/RXD of U5 (TFDU 4300) S = TXIR/RXIR connected to TXD/RXD O = TXIR/RXIR Not connected to TXD/RXD	By default not installed. PCB traces short these jumpers (bottom of PCB)
JP1	Hardware control of Header RA0 signal and MCP2120 BAUD0 signal S = Signal Connected to Vss O = Signal Connected to VDD	
JP2	Hardware control of Header RA1 signal and MCP2120 BAUD1 signal S = Signal Connected to Vss O = Signal Connected to VDD	
JP3	Hardware control of Header RC0 signal and MCP2120 BAUD2 signal S = Signal Connected to Vss O = Signal Connected to VDD	
JP4	Hardware control of Header RC1 signal and MCP2120 MODE signal S = Signal Connected to Vss O = Signal Connected to VDD	
JP5	Hardware control of Header RA3 signal and MCP2120 EN signal S = Signal Connected to Vss O = Signal Connected to VDD	
JMP1	Connects MCP2120 RX signal to either Header 1's RX signal or Header 2/Header 3 RX signals	Note 1
JP6	Connects MCP2120 RX signal to Header 1's TX signal	Used when the MCP2120 communicates directly from the DB-9 connector. (Note 1)
JMP2	Connects MCP2120 16XCLK signal to either Header 1's 16XCLK signal or to Header 2/Header 3's 16XCLK signals	
JMP3	Connects MCP2120 TX signal to Header 1's TX signal or Header 2/Header 3 TX signals	Note 2
JP7	Connects MCP2120 TX signal to Header 1's RX signal	Used when the MCP2120 communicates directly from the DB-9 connector. (Note 2)

Legend: S = Jumper is shorted (Closed) O = Jumper is Open

Note 1: The MCP2120's RX signal is either connected via JMP1 or JP6 (but not both at the same time).

2: The MCP2120's TX signal is either connected via JMP3 or JP7 (but not both at the same time).

MCP212X Developer's Daughter Board User's Guide

2.4 MAKING A DEMO SYSTEM

The MCP212X Developer's Daughter Board requires a clock source and either a Host Controller or a UART circuit. To demonstrate the board, the easiest method is to use one of the compatible PICDEM™ Demo Boards. A good choice is the PICDEM™ HPC Explorer Demo Board. This allows the MCP2120 device to interface to either:

- PIC18F8722's EUSART1
- PIC18F8722's EUSART2
- PICDEM™ HPC Explorer Demo Board's DB-9 connector (MAX3232C)

Additional instructions for performing a demo using the PICDEM™ HPC Explorer Demo Board are shown in **Appendix D. "Using the MCP212X Developer's Daughter Board with the PICDEM™ HPC Explorer Demo Board"**. **Appendix E. "Using the MCP212X Developer's Daughter Board with the PICDEM™ FS USB Demo Board"** supplies instructions for performing a demo using the PICDEM™ FS USB Demo Board. **Appendix F. "Configuring the HyperTerminal® Program"** may be useful for configuring the HyperTerminal program on the PC.

System Requirements

Table 2-3 shows the requirements for a system that can be used to demonstrate the MCP212X Developer's Daughter Board.

System Setup

The system setup requires a PC with two serial communication ports (UARTs) and HyperTerminal, the system application program. Two PICDEM™ HPC Explorer Demo Boards and two MCP212X Daughter Boards are then needed.

Note: The MCP2122 may be installed in U4, or the MCP2120 may be installed in U1. However, these devices should not be installed at the same time.

Figure 2-4 shows a system block diagram.

TABLE 2-3: SYSTEM HARDWARE REQUIREMENTS

Qty	Hardware	Purpose
1	PC with 2 serial ports	The PC will "talk" to each PICDEM™ HPC Explorer Demo Board (Encoder/Decoder board) via the serial port and an instance of the HyperTerminal® program. For consistency, COM 1 will be used to talk to the "System #1" PICDEM™ HPC Explorer Demo Board. Com 2 will be used to communicate to the "System #2" PICDEM™ HPC Explorer Demo Board.
2	Serial Cables	To connect the PC serial ports to each PICDEM™ HPC Explorer Demo Board's serial port.
2	PICDEM™ HPC Explorer Boards	The MCP212X Developer's Daughter Board will be installed into this board for testing.
2	MCP2120 Daughter Boards	This board will be used to communicate with the system under test.
2	2 PICDEM™ HPC Explorer Demo Board Power Supplies (9V DC)	Used to power each of the PICDEM™ HPC Explorer Demo Boards.

FIGURE 2-4: SYSTEM BLOCK DIAGRAM

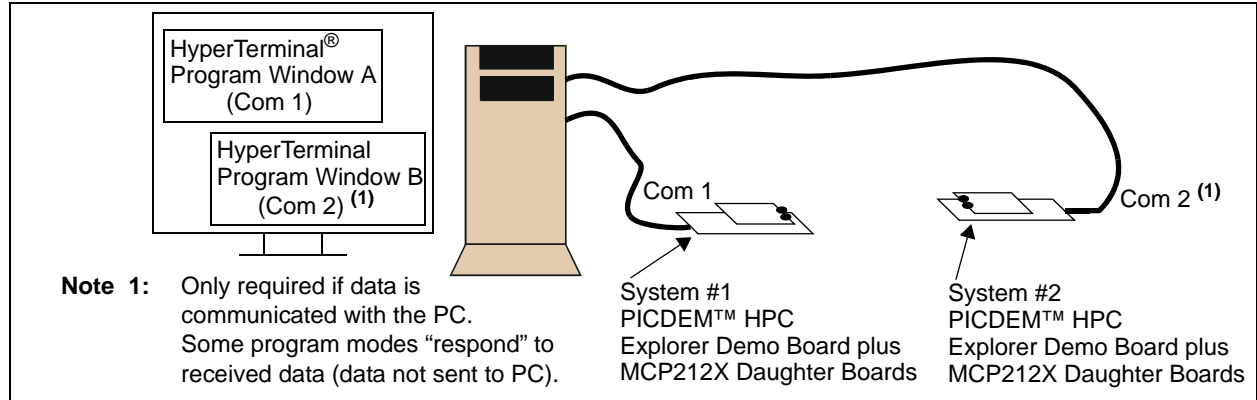

2.4.1 The PICDEM™ Demo Board Firmware Overview

Two firmware programs are supplied with this board. 00063 - HPC.asm is for the PICDEM™ HPC Explorer Demo Board, while 00063 - FS USB.asm is for the PICDEM™ FS USB Demo Board.

The PICDEM™ HPC Explorer Demo Board supports two modes of operation: the Direct-to-PC and Echo modes.

In Direct-to-PC mode, the data byte communicates between the MCP2120 and the PICDEM™ HPC Explorer Demo Board's DB-9 connector (does not communicate with the PIC18F8722). The PIC18F8722 is only used for the 16XCLK signal (for the specified baud rate).

In Echo mode, the data byte that is received is “echoed” in the opposite case (lowercase → uppercase and uppercase → lowercase).

The PICDEM™ FS USB Demo Board only supports Echo mode.

The source code for these programs are available for download from the Microchip web site (www.microchip.com), as well as being available on the CD-ROM supplied with the MCP212X Developer's Daughter Board.

To use these programs, it is required that the MPLAB® IDE be installed on a computer and that one of Microchip's development tools are available to program the board (such as MPLAB® ICD 2).

MCP212X Developer's Daughter Board User's Guide

2.5 MCP212X DEVELOPER'S DAUGHTER BOARD DESCRIPTION

The following sections describe each element of this daughter board in further detail.

2.5.1 Power

The MCP212X Developer's Daughter Board is powered by a 5V supply. This voltage supply may be sourced via the PCB headers.

When the device is used in conjunction with the appropriate PICDEM™ Demo Board, the power is supplied via the connector interface. If the MCP212X Developer's Daughter Board is jumpered into an application circuit via the HD1 connector, the device power supply must be brought over as well.

2.5.2 MCP212X IrDA® Standard Encoder/Decoder Device

This demo board highlights the MCP2122 device (U4) and MCP2120 device (U1) to demonstrate the implementation of an IR port in an embedded system application. The MCP2120 device handles the encoding/decoding of the UART/IR bit stream.

Further Host Controller interface information is available in the device documentation:

- MCP2122 Data Sheet, "Infrared Encoder/Decoder" (DS21894)
- MCP2120 Data Sheet, "Infrared Encoder/Decoder" (DS21618)
- AN946, "Interfacing the MCP2122 to the Host Controller" (DS00946)

2.5.2.1 MCP2122 OPERATION

The MCP2122 (U4) implements an IrDA standard encoder/decoder. The baud rate is determined by the frequency of the 16XCLK input.

The key signals for the MCP2122-to-microcontroller (Host UART) interface are shown in Table 2-4. The key signals for the MCP2122-to-IR transceiver circuit are shown in Table 2-5.

TABLE 2-4: MCP2122 HOST UART INTERFACE PINS

Pin Name	Pin Number (PDIP)	Pin Type	Buffer Type	Description
TX	2	I	TTL	Asynchronous receive; from Host Controller UART
RX	3	O	—	Asynchronous transmit; to Host Controller UART
16XCLK	1	I	TTL	16 x Clock

Legend: TTL = TTL compatible input ST = Schmitt Trigger input with CMOS levels
I = Input O = Output

TABLE 2-5: MCP2122 IR INTERFACE PINS

Pin Name	Pin Number (PDIP)	Pin Type	Buffer Type	Description
TXIR	2	O	—	Asynchronous transmit to IrDA® standard transceiver
RXIR	3	I	ST	Asynchronous receive from infrared transceiver

Legend: A = Analog P = Power
I = Input O = Output

In addition to the signals described in Table 2-4 and Table 2-5, the MCP2120 RESET input is connected to the RESET output of the Host Controller.

Installation and Operation

2.5.2.2 MCP2120 OPERATION

The MCP2120 (U1) implements an IrDA standard encoder/decoder. The baud rate is determined by the device frequency and the state of the BAUD2:BAUD0 pins. The MCP2120 also has a Software Baud Rate mode which controls the baud rate via the Host Controller software.

The key signals for the MCP2120-to-microcontroller (Host UART) interface are shown in Table 2-6. The key signals for the MCP2120-to-IR transceiver circuit are shown in Table 2-7.

TABLE 2-6: MCP2120 HOST UART INTERFACE PINS

Pin Name	Pin Number (PDIP)	Pin Type	Buffer Type	Description
TX	12	I	TTL	Asynchronous receive; from Host Controller UART
RX	11	O	—	Asynchronous transmit; to Host Controller UART
BAUD0	10	I	TTL	BAUD2:BAUD0 specifies the Baud rate of the device, or if the device operates in Software Baud Rate mode
BAUD1	9	I	TTL	
BAUD3	8	I	TTL	
MODE	7	I	TTL	Selects the device mode (Data/Command) for Software Baud Rate operation

Legend: TTL = TTL compatible input ST = Schmitt Trigger input with CMOS levels
I = Input O = Output

TABLE 2-7: MCP2120 IR INTERFACE PINS

Pin Name	Pin Number (PDIP)	Pin Type	Buffer Type	Description
TXIR	6	O	—	Asynchronous transmit to IrDA [®] standard transceiver
RXIR	5	I	ST	Asynchronous receive from an infrared transceiver

Legend: A = Analog P = Power
I = Input O = Output

In addition to the signals described in Table 2-6 and Table 2-7, the MCP2120 RESET input is connected to the RESET output of the Host Controller. The EN input can be either hard-wired or controlled by the Host Controller.

MCP212X Developer's Daughter Board User's Guide

2.5.3 IR Transceiver Circuit

The IR transceiver circuit uses a Vishay® TFDU 4300 integrated optical transceiver. Footprints for an optional optical transceiver are implemented. These footprints are for the Vishay TFDU 4100 and the Agilent® HSDL-3000. Jumpers are used to allow all three implementations to be installed, but with only one connected to the MCP2120 TXIR and RXIR pins.

2.5.4 Signal Header

To allow easy access to many of the system signals, a header (HD1) was placed on one of the edges of the board. This allows the signals from the MCP2120 to be easily accessed and connected into an existing application for initial development or proof-of-concept.

FIGURE 2-5: 14-PIN SIGNAL INTERFACE HEADER HD1

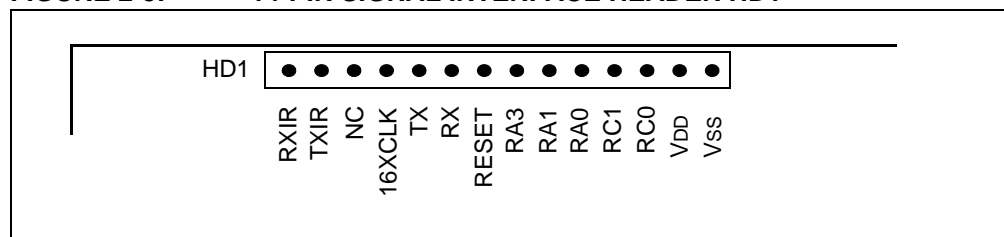

Appendix A. Schematic and Layouts

A.1 INTRODUCTION

This appendix contains the following schematics and layouts for the MCP212X Developer's Daughter Board:

- Board Schematic – Headers and Jumpers
- Board Schematic – Circuitry
- Board – Component Layer
- Board – Top Layer
- Board – Bottom Layer

A.2 SCHEMATICS AND PCB LAYOUT

The layer order is shown in Figure A-1.

FIGURE A-1: LAYER ORDER

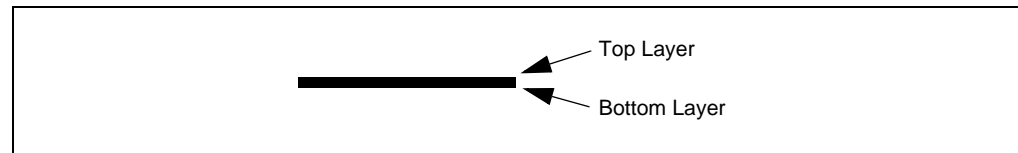

MCP212X Developer's Daughter Board User's Guide

FIGURE A-2: MCP212X DEVELOPER'S DAUGHTER BOARD SCHEMATIC – PAGE 1

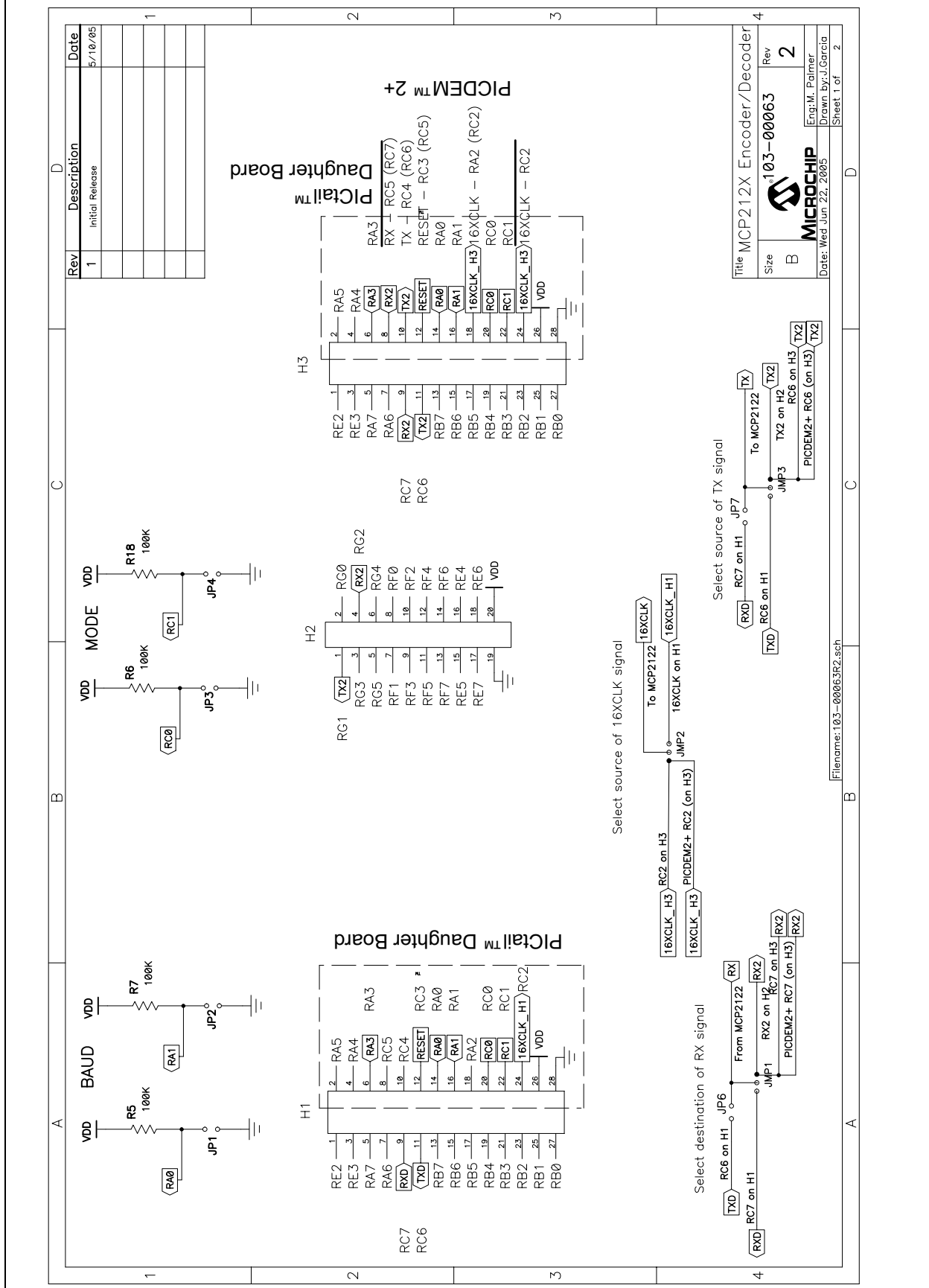

FIGURE A-3: MCP212X DEVELOPER'S DAUGHTER BOARD SCHEMATIC – PAGE 2

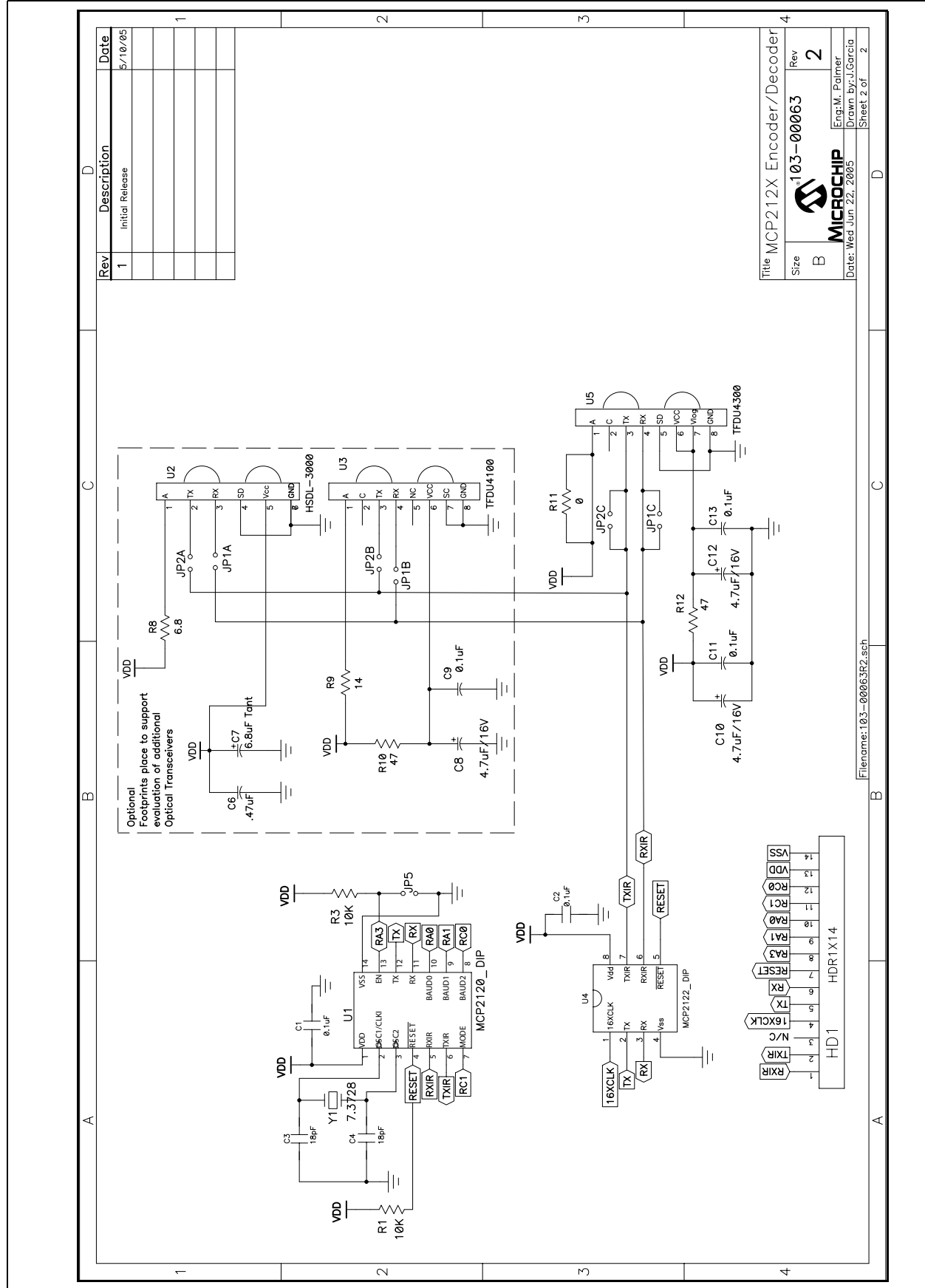
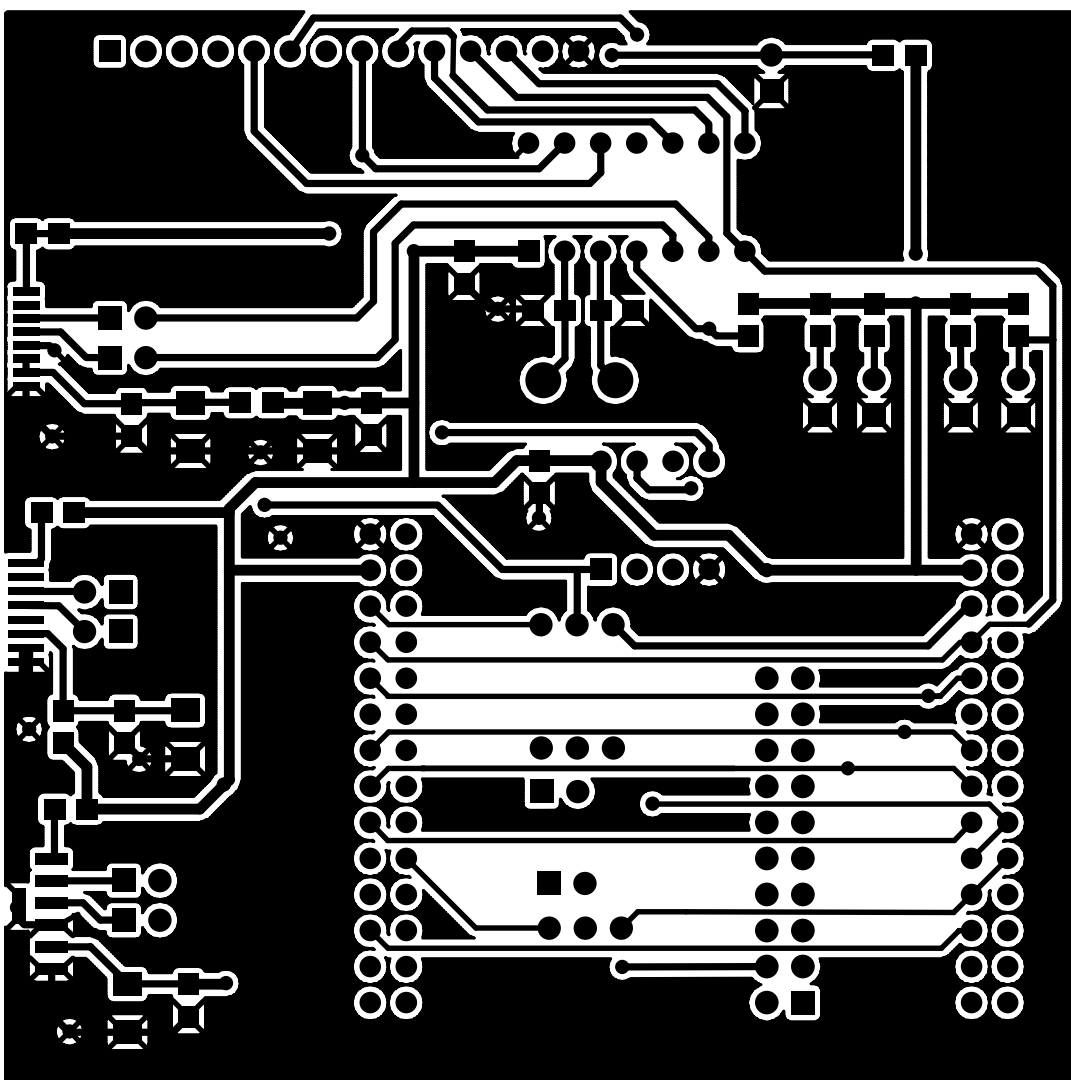
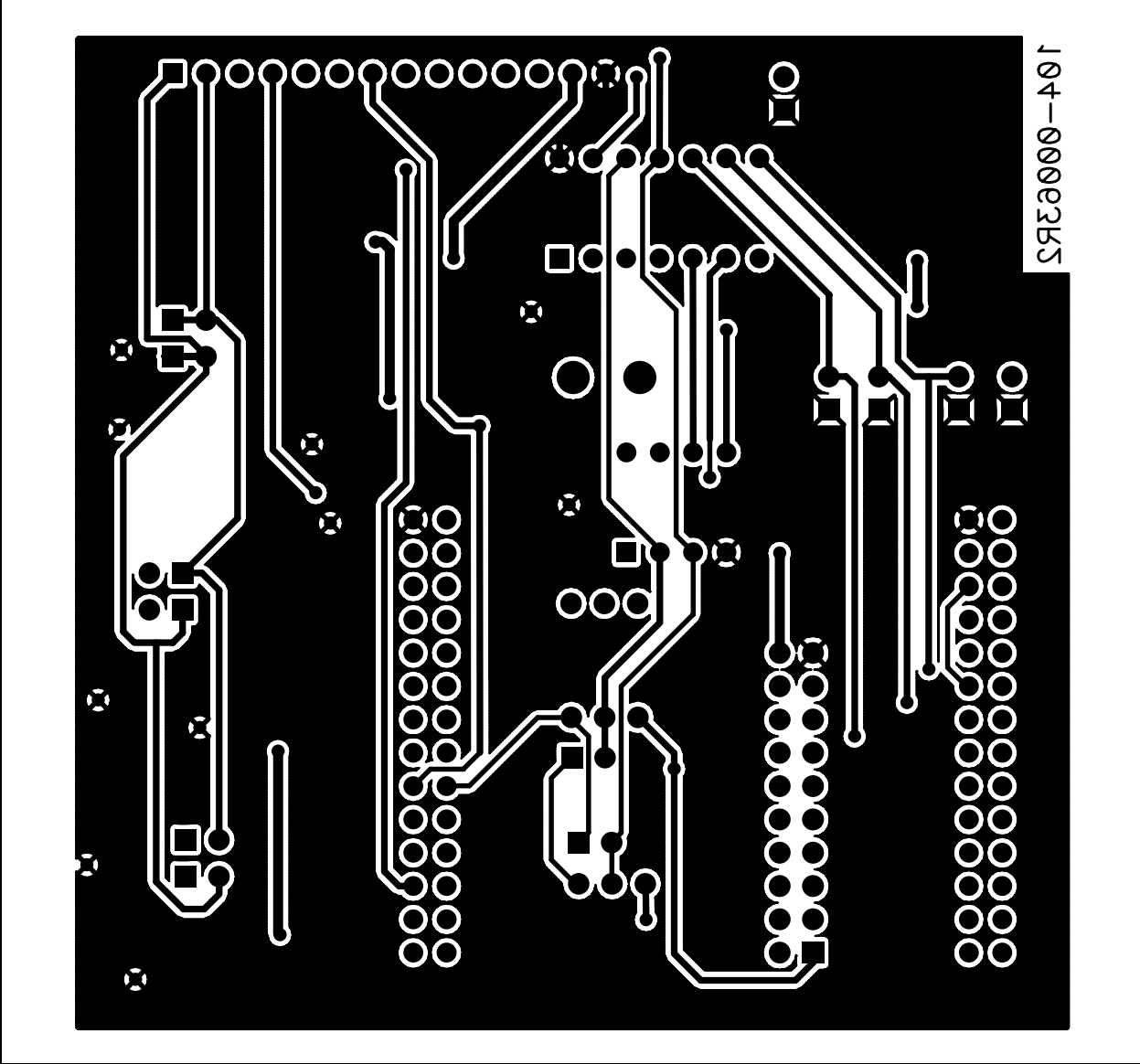

FIGURE A-5: MCP212X DEVELOPER'S DAUGHTER BOARD LAYOUT – TOP LAYER



MCP212X Developer's Daughter Board User's Guide

FIGURE A-6: MCP212X DEVELOPER'S DAUGHTER BOARD LAYOUT – BOTTOM LAYER



Appendix B. Bill of Materials (BOM)

The MCP212X Developer's Daughter Board allows the MCP2120 or MCP2122 device to be evaluated. The board also allows the customer to evaluate the operation of one of three optical transceiver devices.

Table B-1 shows the components that are installed in the MCP212X Developer's Daughter Board PCB, while Table B-2 shows the components that are NOT installed on the MCP212X Developer's Daughter Board PCB.

TABLE B-1: BOM – COMPONENTS INSTALLED

Qty	Reference	Description	Manufacturer	Part Number
4	C1, C2, C11, C13	0.1 μ F (SMT)	Panasonic [®] - ECG	ECJ-2VB1C104K
2	C3, C4	18 pF (SMT)	Yageo America	0805CG180J9B200
2	C10, C12	4.7 μ F/16V (SMT)	Panasonic - ECG	ECS-T1AY475R
1	H1, H3	2x14 Male connector Header	Jameco Valuepro	2012-254-2X14SG
1	H2	2x10 Male connector Header	Jameco Valuepro	7000-2X10SG
1	HD1	1x14 Male connector Header	Jameco Valuepro	7000-1x14SG
3	JMP1, JMP2, JMP3	1x3 Jumper Stakes (Male)	Jameco Valuepro	7000-1x3SG
7	JP1, JP2, JP3, JP4, JP5, JP6, JP7	1x2 Jumper Stakes (Male)	Jameco Valuepro	7000-1x2SG
2	R1, R3	10 k Ω (SMT)	Panasonic - ECG	ERJ-6ENF1002V
4	R5, R6, R7, R18	100 k Ω (SMT)	Panasonic - ECG	ERJ-6ENF1003V
1	R12	47 Ω (SMT)	Panasonic - ECG	ERJ-6ENF47R5V
1	U1	14-pin DIP Socket	Microchip Technology Inc.	
1	U4	8-pin DIP Socket	Jameco Valuepro	6100-14
1		MCP2122 (provided)	Jameco Valuepro	6100-8
1	U5	TFDU-4300	Microchip Technology Inc.	
2	Y1	Crystal Sockets pin	Manufacturing Corp	0667-0-15-01-30-27-10-0
1		7.3728 MHz Crystal (Through hole)	CTS Frequency Controls	MP073
1	—	PCB 105-00063 (R2 or greater)	Microchip Technology Inc.	
8	—	Jumper Shunt (used on JP1, JP2, JP3, JP4, JP5, JP6, JP7 and JMP2)	Jameco Valuepro	2012JH

MCP212X Developer's Daughter Board User's Guide

TABLE B-2: BOM – OPTIONAL COMPONENTS, NOT INSTALLED

Qty	Reference	Description	Manufacturer	Part Number
0	C6	0.47 μ F (SMT)		
0	C7	6.8 μ F Tantalium (SMT)		
0	C8	4.7 μ F/16V (SMT)		
0	C9	0.1 μ F (SMT)	Panasonic - ECG	ECJ-2VB1C104K
0	JP1A, JP1B, JP1C, JP2A, JP2B, JP2C	1x2 Jumper Stakes (Male)	Jameco Valuepro	7000-1x2SG
0	R8	6.8 Ω (SMT)		
0	R9	14 Ω (SMT)		
0	R10	47 Ω (SMT)		
0	R11	0 Ω (SMT)		
1	U1	MCP2120 (In the Sample Pack)	Microchip Technology Inc.	MCP2120-I/P
0	U2	HSDL-3000	Agilent [®]	HSDL-3000
0	U3	TFDU-4100	Vishay [®]	TFDU-4100
0	—	Jumper Shunt (used on JP1A and JP2A, or JP1B and JP2B, or JP1C and JP2C)	Jameco Valuepro	2012JH

MCP212X Developer's Daughter Board User's Guide

NOTES:

Appendix D. Using the MCP212X Developer's Daughter Board with the PICDEM™ HPC Explorer Demo Board

D.1 DEMONSTRATION USING TWO PICDEM™ HPC EXPLORER DEMO BOARDS

To perform a demonstration of the MCP212X Developer's Daughter Board, two systems are needed. Each system is a MCP212X Developer's Daughter Board (MCP212XEV-DB) plus the PICDEM™ HPC Explorer Demo Board (DM183022). Figure D-1 shows a block diagram of the demonstration system.

FIGURE D-1: SYSTEM BLOCK DIAGRAM

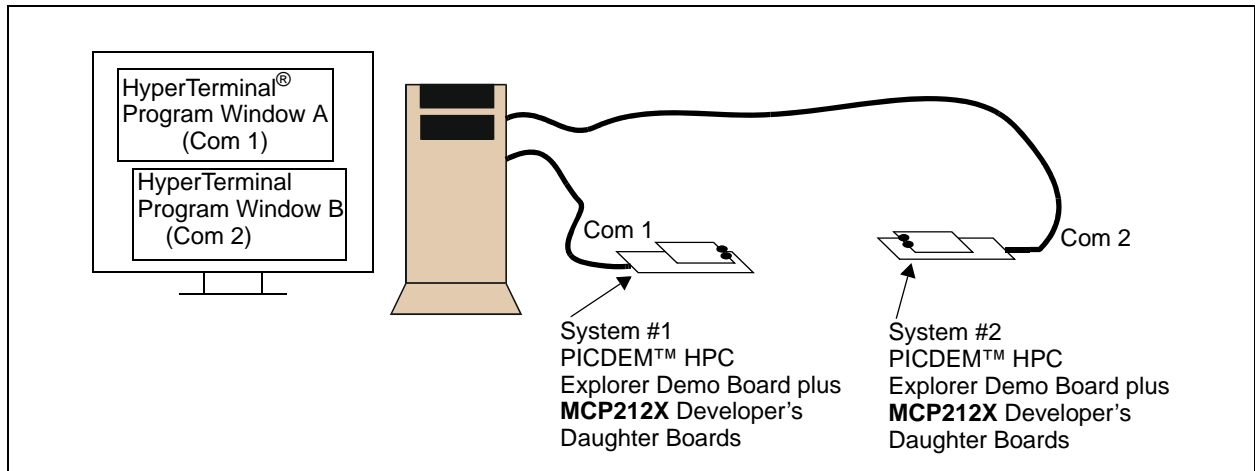

The firmware for these demos is available on the Microchip web site, as well as on the AIPD Evaluation Board CD-ROM. The filename is 00063 - HPC .asm. This code must be programmed into the PICDEM™ HPC Explorer Demo Board's PIC18F8722 for demo operation. This code supports two demos. The demo executed is dependent on the state of the JP4 jumper.

Note: Other PICDEM™ Demo Boards may be used, but appropriate firmware needs to be installed to demonstrate the system.

MCP212X Developer's Daughter Board User's Guide

The crystal frequency of the PICDEM™ Demo Board determines the error rates for the EUSART baud rates, as well as the 16XCLK generation (for the MCP2122). So for the PICDEM™ HPC Explorer Demo Board, the default crystal is 10 MHz (does have a 4x PLL). Therefore, the 16XCLK frequency for 115200 baud has an error outside usable limits for IrDA® standard communication for both 10 MHz and 40 MHz operation (see Table D-1). The demo will be limited to 9600 baud. Table D-2 shows the SPBRG values for the EUSART at the same crystal frequencies.

TABLE D-1: PR VALUES FOR PWM⁽¹⁾

Desired Baud Rate	16XCLK	@ 40 MHz ⁽²⁾		@ 20 MHz ⁽²⁾		@ 14.759 MHz ⁽²⁾		@ 10 MHz ⁽²⁾	
		PR ⁽³⁾	%Error	PR ⁽³⁾	%Error	PR ⁽³⁾	%Error	PR ⁽³⁾	%Error
9600	153,600	64	-0.16%	32	1.36%	23	0%	15	-1.73%
19200	307,200	32	1.36%	15	-1.73%	11	0%	7	-1.73%
38400	614,400	15	-1.73%	7	-1.73%	5	0%	3	-1.73%
57600	921,600	10	1.36%	4	-8.51%	3	0%	2	9.58%
115200	1,843,200	4	-8.51%	2	-35.6%	1	0%	1	32.18%

- Note 1:** Shaded values indicate a % error that is larger than should be used.
- 2:** The following shows the PICDEM™ Demo Board device frequencies:
 PICDEM™ HPC Explorer Demo Board has a 10 MHz crystal installed (4xPLL -> 40 MHz).
 PICDEM™ FS USB Demo Board has a 20 MHz crystal installed.
 PICDEM™ 2 Plus Demo Board has a 4 MHz crystal installed.
 PICDEM™ LCD has a socket for an external canned oscillator (also has an internal 8 MHz RC).
- 3:** CCP Duty Cycle should be approximately 50% of the PR value.

TABLE D-2: SPBRG VALUES FOR EUSART⁽¹⁾

Desired Baud Rate	@ 40 MHz ⁽²⁾		@ 20 MHz ⁽²⁾		@ 14.759 MHz ⁽²⁾		@ 10 MHz ⁽²⁾	
	SPBRG ⁽³⁾	%Error	SPBRG ⁽³⁾	%Error	SPBRG ⁽³⁾	%Error	SPBRG ⁽³⁾	%Error
9600	225	-1.73%	129	-0.16%	95	0%	64	-0.16%
19200	129	-0.16%	64	-0.16%	47	0%	32	1.36%
38400	64	-0.16%	32	1.36%	23	0%	15	-1.73%
57600	42	-0.94%	21	1.36%	15	0%	10	1.36%
115200	21	1.36%	10	1.36%	7	0%	4	-8.51%

- Note 1:** Shaded values indicate a % error that is larger than should be used.
- 2:** The following shows the PICDEM™ Demo Board device frequencies:
 PICDEM™ HPC Explorer Demo Board has a 10 MHz crystal installed (4xPLL -> 40 MHz).
 PICDEM™ FS USB Demo Board has a 20 MHz crystal installed.
 PICDEM™ 2 Plus Demo Board has a 4 MHz crystal installed.
 PICDEM™ LCD has a socket for an external canned oscillator (also has an internal 8 MHz RC).
- 3:** SYNC = 0, BRGH = 1, BRG16 = 0.

Using the MCP212X Developer's Daughter Board with the PICDEM™ HPC Explorer Demo Board

D.1.1 Demo #1 Operation

In Demo #1, the MCP212X Developer's Daughter Board will communicate directly to the PICDEM™ HPC Explorer Demo Board's DB-9 connector (and then to the PC). The PICDEM™ HPC Explorer Demo Board is used to determine the communication baud rate (9600) via the JP3, JP2 and JP1 jumper states. Given this state, the PICmicro® MCU can then supply the 16XCLK frequency to the MCP2122. Power is supplied over the J1 and J2 interface headers. Jumper JP4 is used to select which demonstration program to run. Figure D-2 shows the jumper configuration for Demo #1.

FIGURE D-2: DEMO #1 CONFIGURATION

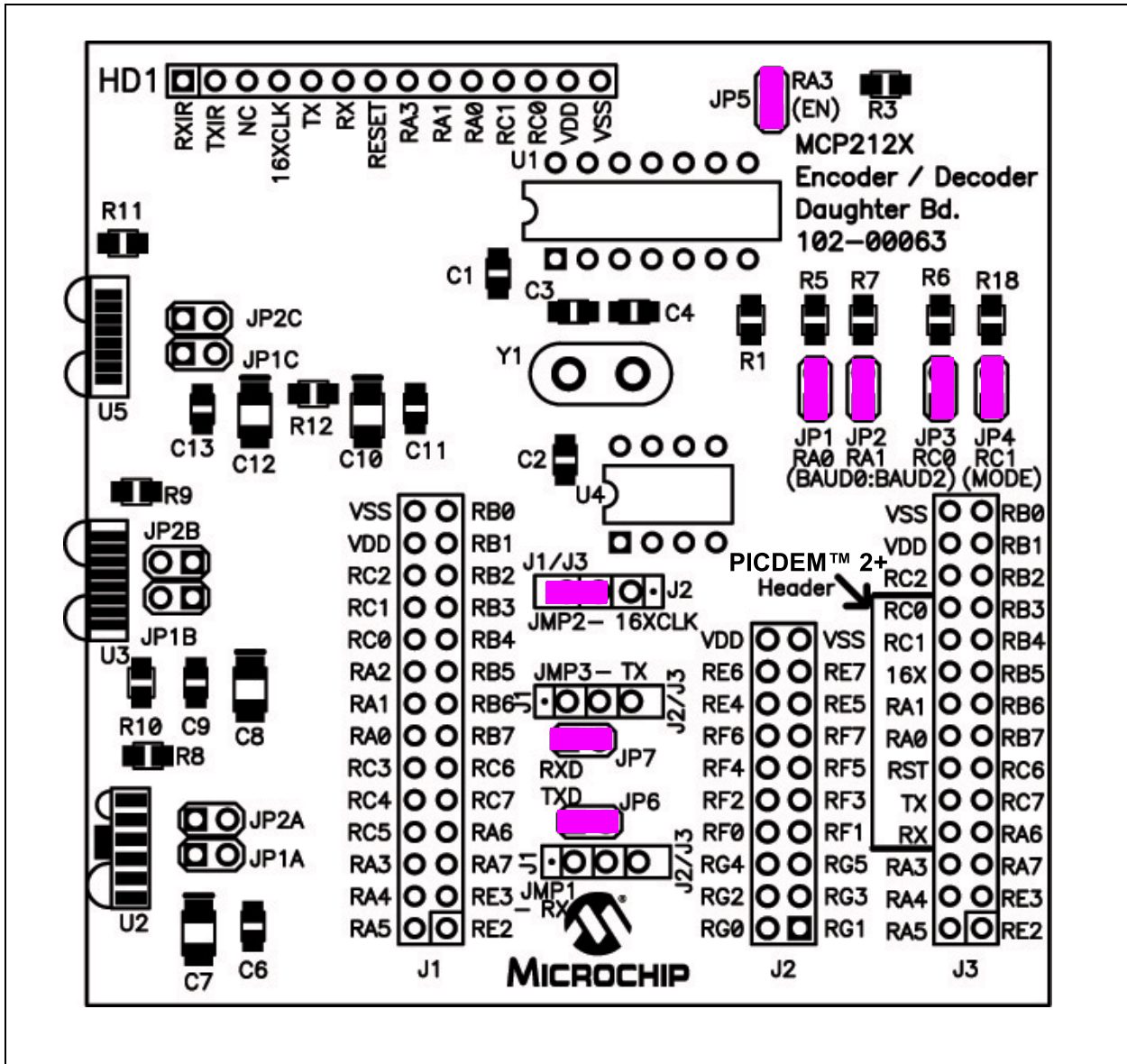

MCP212X Developer's Daughter Board User's Guide

Table D-3 shows the steps for Demo #1 operation.

TABLE D-3: DEMO #1 STEPS

Step	Action	Result
1	Place both devices on a flat surface about 25 cm (10") apart, with the IR ports facing each other.	—
2	On the System #1 Unit: The jumpers must be configured as in Figure D-3.	—
3	On the System #1 Unit: Apply power to the unit via the 9V power supply.	On the System #1 Unit: The green power LED (D) will turn on.
4	On the System #1 Unit: Connect the PC serial port cable that is connected to COM1.	—
5	On the System #2 Unit: Insert the MCP212X Developer's Daughter Board into the PICDEM™ HPC Explorer Demo Board. Ensure that the jumpers are configured as in Figure D-2.	Test unit will echo the received Alpha character (changing the case; upper to lower and lower to upper).
6	On the System #2 Unit: Apply power to the unit via the 9V power supply.	On the System #2 Unit: The green power LED (D) will turn on.
7	On the System #2 Unit: Connect the PC serial port cable that is connected to COM2.	—
8	On the System #1 Unit: Depress and release Switch 2 (S2 – $\overline{\text{MCLR}}$).	—
9	On the System #2 Unit: Depress and release Switch 2 (S2 – $\overline{\text{MCLR}}$).	—
10	On the PC: Open the HyperTerminal® program window for COM 1. Ensure that the window indicates that the HyperTerminal program is connected.	—
11	On the PC: In the HyperTerminal program COM1 window, type alpha-numeric characters (such as "123456 asdfg").	On the PC: In the HyperTerminal program COM 2 window, the same characters should be displayed ("123456 asdfg").
12	On the PC: In the HyperTerminal program COM2 window, depress the Return key and type alpha-numeric characters (such as "7890 hjkl;").	On the PC: In the HyperTerminal program COM 1 window, the same characters should be displayed ("7890 hjkl;") on the line below the "123456 asdfg" characters.
13	On the System #2 Unit: Power-down the board and remove the tested MCP212x Daughter Board.	—
14	Go to Step #5	—

Using the MCP212X Developer's Daughter Board with the PICDEM™ HPC Explorer Demo Board

D.1.2 Demo #2 Operation

In Demo #2, the System 2 unit will echo any alpha character received, changing the case of the character (lowercase to uppercase/uppercase to lowercase). The System 1 unit is connected to the PC, while the System 2 unit is not connected, though it still needs to be powered. The PICDEM™ HPC Explorer Demo Board is used to determine the communication baud rate (9600) via the JP3, JP2 and JP1 jumper states. Given this state, the PICmicro® MCU can then supply the 16XCLK frequency to the MCP2122. Power is supplied over the J1 and J2 interface headers. Jumper JP4 is used to select which demo program to run. Figure D-3 shows the jumper configuration for Demo #2.

Table D-3 shows the steps for Demo #2.

FIGURE D-3: DEMO #2 CONFIGURATION

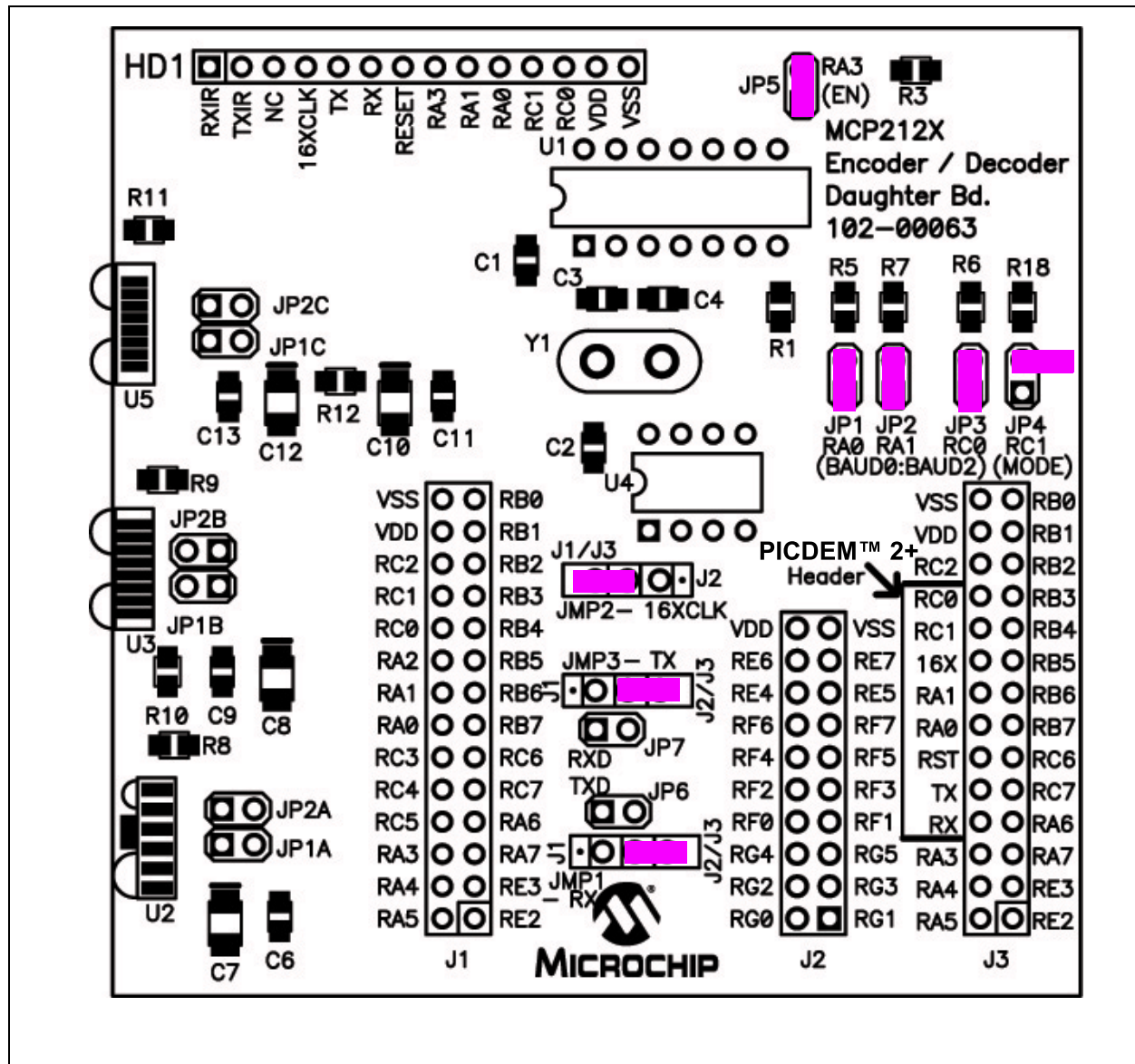

MCP212X Developer's Daughter Board User's Guide

TABLE D-4: DEMO #2 STEPS

Step	Action	Result
1	Place both devices on a flat surface about 25 cm (10") apart, and with the IR ports facing each other.	—
2	On the System #1 Unit: The jumpers must be configured as in Figure D-3.	—
3	On the System #1 Unit: Apply power to the unit via the 9V power supply.	On the System #1 Unit: The green power LED (D) will turn on.
4	On the System #1 Unit: Connect the PC serial port cable that is connected to COM1.	—
5	On the System #2 Unit: Insert the MCP212X Developer's Daughter Board into the PICDEM™ HPC Explorer Demo Board. Ensure that the jumpers are configured as in Figure D-2.	Test unit will echo the received Alpha character (changing the case; uppercase to lowercase and lowercase to uppercase)
6	On the System #2 Unit: Apply power to the unit via the 9V power supply.	On the System #2 Unit: The green power LED (D) will turn on.
7	On the System #1 Unit: Depress and release Switch 2 (S2 – $\overline{\text{MCLR}}$).	—
8	On the System #2 Unit: Depress and release Switch 2 (S2 – $\overline{\text{MCLR}}$).	—
9	On the PC: Open the HyperTerminal® program window for COM 1. Ensure that the window indicates that the HyperTerminal program is connected	—
10	On the PC: In the HyperTerminal program window, type an "a".	On the PC: The HyperTerminal window will display an "aA".
11	On the PC: Type some additional alpha characters into the HyperTerminal program window.	On the PC: The typed alpha character will echo where the case has changed; lowercase -> uppercase and uppercase -> lowercase.
12	On the System #2 Unit: Power down the board and remove the tested MCP212X Developer's Daughter Board.	—
13	Go to Step #5	—

Appendix E. Using the MCP212X Developer's Daughter Board with the PICDEM™ FS USB Demo Board

E.1 DEMONSTRATION WITH THE PICDEM FS USB DEMO BOARD

To perform a demonstration of the MCP212X, two systems are needed. One system will operate as an encoder/decoder passing information to the PC. This system may be either the:

- MCP212X Developer's Daughter Board (MCP212XEV-DB) plus the PICDEM™ HPC Explorer Demo Board (DM183022) or
- MCP2120 Developer's Board (DM163008)

The second system is a MCP212X Developer's Daughter Board (MCP212XEV-DB) plus the PICDEM™ FS USB Demo Board (DM163025). This system operates in a stand-alone mode and will “echo” the characters it receives (changing the case of the received alpha character). Figure E-1 shows a block diagram of the demonstration system.

FIGURE E-1: SYSTEM BLOCK DIAGRAM

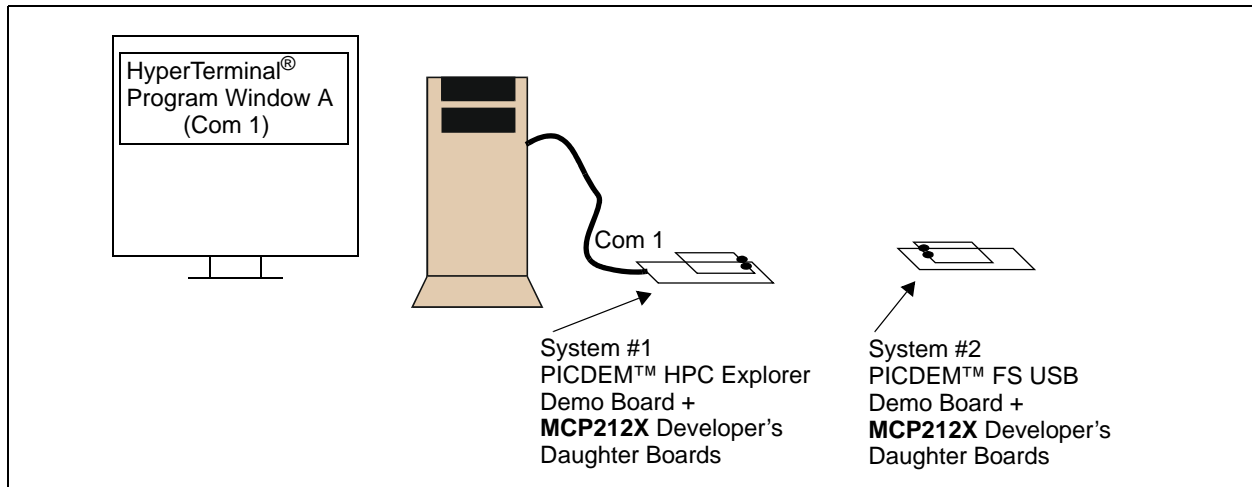

The firmware for these demos is available on the Microchip web site, as well as on the AIPD Evaluation Board CD-ROM. The file name is 00063 - FS USB.asm. This code must be programmed into the PICDEM™ FS USB Demo Board's PIC18F4550 for demo operation. This code requires the JP4 jumper to be in the documented state.

Note: Other PICDEM™ Demo Boards may be used, but appropriate firmware needs to be installed to demonstrate the system.

MCP212X Developer's Daughter Board User's Guide

The crystal frequency of the PICDEM™ Demo Board determines the error rates for the EUSART baud rates, as well as the 16XCLK generation (for the MCP2122). So, for the PICDEM™ FS USB Demo Board, the default crystal is 20 MHz. The 16XCLK frequency for 115200 and 57600 baud has an error outside usable limits for IrDA® standard communication for 20 MHz operation (see Table E-1). Therefore, the demo will be limited to 9600 baud. Table E-2 shows the SPBRG values for the EUSART at the same crystal frequencies.

TABLE E-1: PR VALUES FOR PWM⁽¹⁾

Desired Baud Rate	16XCLK	@ 40 MHz ⁽²⁾		@ 20 MHz ⁽²⁾		@ 14.759 MHz ⁽²⁾		@ 10 MHz ⁽²⁾	
		PR ⁽³⁾	%Error	PR ⁽³⁾	%Error	PR ⁽³⁾	%Error	PR ⁽³⁾	%Error
9600	153,600	64	-0.16%	32	1.36%	23	0%	15	-1.73%
19200	307,200	32	1.36%	15	-1.73%	11	0%	7	-1.73%
38400	614,400	15	-1.73%	7	-1.73%	5	0%	3	-1.73%
57600	921,600	10	1.36%	4	-8.51%	3	0%	2	9.58%
115200	1,843,200	4	-8.51%	2	-35.6%	1	0%	1	32.18%

- Note 1:** Shaded values indicate a % error that is larger than should be used.
- 2:** The following shows the PICDEM™ Demo Board device frequencies:
 PICDEM™ HPC Explorer Demo Board has a 10 MHz crystal installed (4xPLL -> 40 MHz),
 PICDEM™ FS USB Demo Board has a 20 MHz crystal installed,
 PICDEM™ 2 Plus Demo Board has a 4 MHz crystal installed,
 PICDEM™ LCD has a socket for an external canned oscillator (also has an internal 8 MHz RC).
- 3:** CCP duty cycle should be approximately 50% of the PR value.

TABLE E-2: SPBRG VALUES FOR EUSART⁽¹⁾

Desired Baud Rate	@ 40 MHz ⁽²⁾		@ 20 MHz ⁽²⁾		@ 14.759 MHz ⁽²⁾		@ 10 MHz ⁽²⁾	
	SPBRG ⁽³⁾	%Error	SPBRG ⁽³⁾	%Error	SPBRG ⁽³⁾	%Error	SPBRG ⁽³⁾	%Error
9600	225	-1.73%	129	-0.16%	95	0%	64	-0.16%
19200	129	-0.16%	64	-0.16%	47	0%	32	1.36%
38400	64	-0.16%	32	1.36%	23	0%	15	-1.73%
57600	42	-0.94%	21	1.36%	15	0%	10	1.36%
115200	21	1.36%	10	1.36%	7	0%	4	-8.51%

- Note 1:** Shaded values indicate a % error that is larger than should be used.
- 2:** The following shows the PICDEM™ Demo Board device frequencies:
 PICDEM™ HPC Explorer Demo Board has a 10 MHz crystal installed (4xPLL -> 40 MHz),
 PICDEM™ FS USB Demo Board has a 20 MHz crystal installed,
 PICDEM™ 2 Plus Demo Board has a 4 MHz crystal installed,
 PICDEM™ LCD has a socket for an external canned oscillator (also has an internal 8 MHz RC).
- 3:** SYNC = 0, BRGH = 1, BRG16 = 0.

Using the MCP212X Developer's Daughter Board with the PICDEM™ FS USB Demo Board

E.1.1 Demo #1 Operation

In Demo #1, the System 2 unit will echo any alpha character received, changing the case of the character (lowercase to uppercase/uppercase to lowercase). The System 1 unit is connected to the PC, while the System 2 unit is not connected, though it still needs to be powered. The PICDEM™ FS USB Demo Board is used to determine the communication baud rate (9600) via the JP3, JP2 and JP1 jumper states. Given this state, the PICmicro® MCU can then supply the 16XCLK frequency to the MCP2122. Power is supplied over the J3 interface header. Jumper JP4 is used to select which demo program to run. Figure E-2 shows the jumper configuration for Demo #1.

Table E-3 shows the steps for Demo #1.

FIGURE E-2: DEMO #1 CONFIGURATION

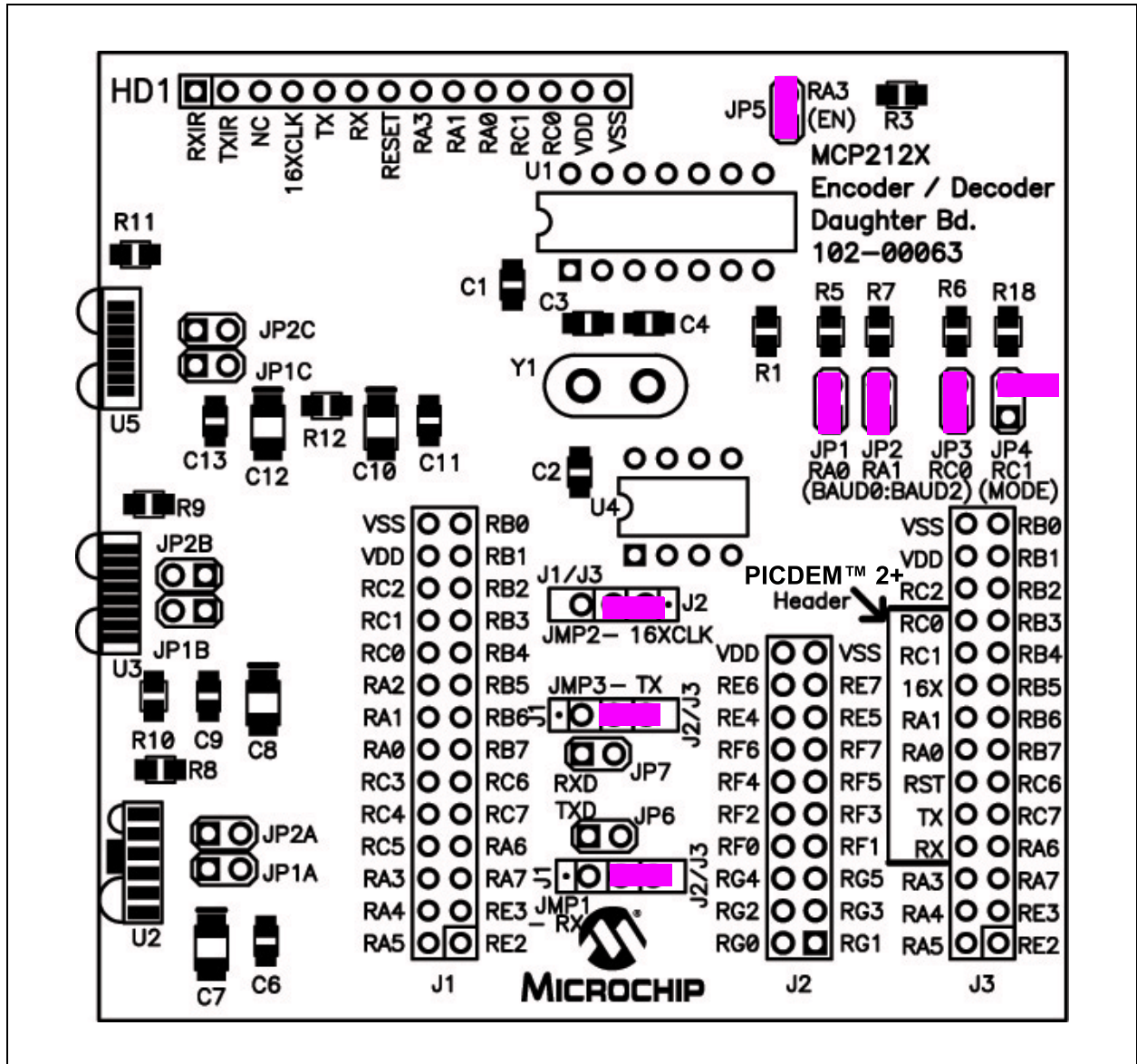

MCP212X Developer's Daughter Board User's Guide

TABLE E-3: DEMO #1 TEST STEPS

Step	Action	Result
1	Place both devices on a flat surface about 25 cm (10") apart, with the IR ports facing each other.	—
2	On the System #1 Unit: The jumpers must be configured as in Figure E-2.	—
3	On the System #1 Unit: Apply power to the unit via the 9V power supply.	On the System #1 Unit: The green power LED (D) will turn on.
4	On the System #1 Unit: Connect the PC serial port cable that is connected to COM1.	—
5	On the System #2: Insert the MCP212X Developer's Daughter Board into the PICDEM™ HPC Explorer Demo Board. Ensure that the jumpers are configured as shown in Figure E-2.	System #2 will echo the received alpha character (changing the case; uppercase to lowercase and lowercase to uppercase).
6	On the System #2: Apply power to the unit via the 9V power supply.	On the System #2: The green power LED (D) will turn on.
7	On the System #1 Unit: Depress and release Switch 2 (S2 – MCLR).	—
8	On the System #2: Depress and release Switch 2 (S2 – MCLR).	—
9	On the PC: Open the HyperTerminal® program window for COM 1. Ensure that the window indicates that the HyperTerminal program is connected.	—
10	On the PC: In the HyperTerminal program window, type an "a".	On the PC: The HyperTerminal program window will display an "aA".
11	On the PC: Type some additional alpha characters in the HyperTerminal program window.	On the PC: The typed alpha character will echo where the case has changed; lowercase -> uppercase and uppercase -> lowercase.
12	On the System #2: Power down the board and remove the tested MCP212X Developer's Daughter Board.	—
13	Go to Step #5	—

Appendix F. Configuring the HyperTerminal® Program

F.1 CONFIGURING THE HyperTerminal® PROGRAM

To ensure that the PC is able to communicate to the PICDEM™ HPC Explorer Demo Board, the HyperTerminal program must be properly configured. This section describes the configuration that the HyperTerminal program should be in.

The screen-shots shown in Figure F-1 through Figure F-6 show the settings of the HyperTerminal program in the Windows® operating system.

You should save each configuration of the HyperTerminal program in order to easily distinguish which HyperTerminal program window is “tacking” with which PICDEM™ HPC Explorer Board.

After opening the HyperTerminal program window, select **Call -> Disconnect**. In the lower-left corner, the HyperTerminal program window will indicate “Disconnected”. Next, in the HyperTerminal program window, select **File -> Properties**. The window in Figure F-2 is shown. Ensure that the appropriate COM port is selected for both the “Golden” unit and the “Testing” unit. Then select the **Configure** button.

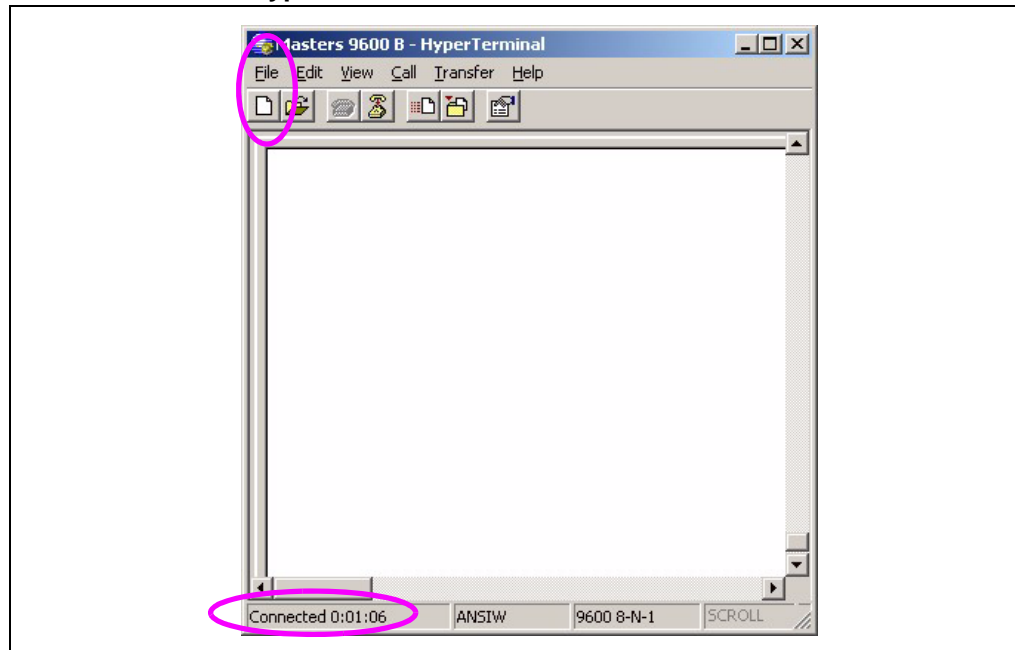
FIGURE F-1: HyperTerminal® PROGRAM MAIN WINDOW

MCP212X Developer's Daughter Board User's Guide

FIGURE F-2: HyperTerminal® PROGRAM PROPERTIES CONNECT TO WINDOW

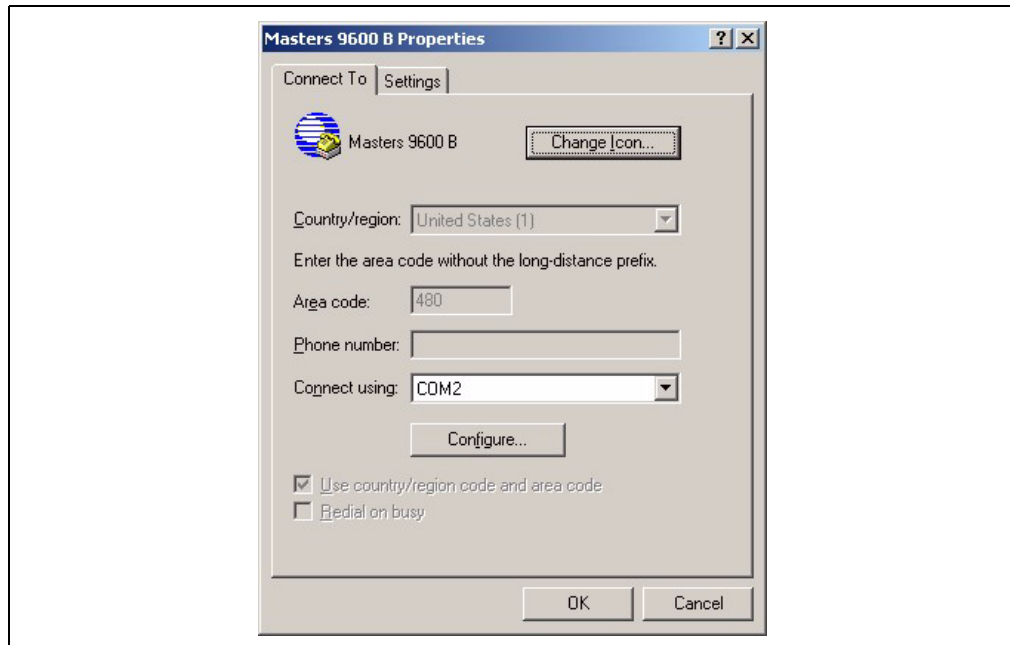

This will open up the Port Settings window. The port settings should be configured as shown in Figure F-3. After configuring the port settings, select **OK**. The Figure F-2 window will be shown. Select the **Settings** tab.

FIGURE F-3: HyperTerminal® PROGRAM PROPERTIES CONFIGURATION WINDOW

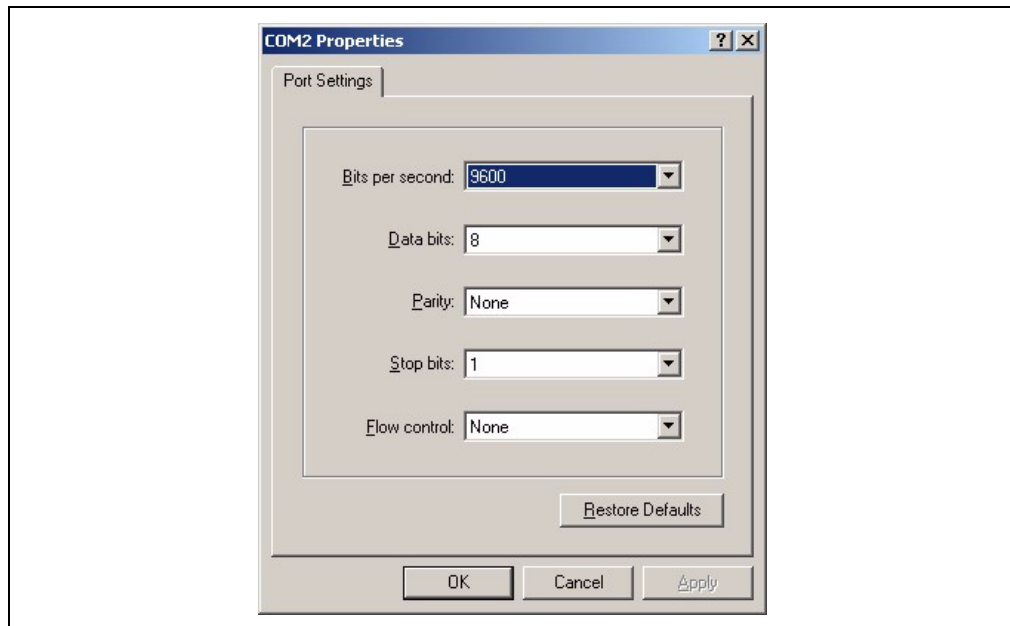

Configuring the HyperTerminal® Program

The window will now look as shown in Figure F-4. Ensure that your settings match the settings shown. Select the **ASCII Setup** button. This will open the ASCII Setup window (Figure F-5).

FIGURE F-4: HyperTerminal® PROGRAM PROPERTIES SETTINGS WINDOW

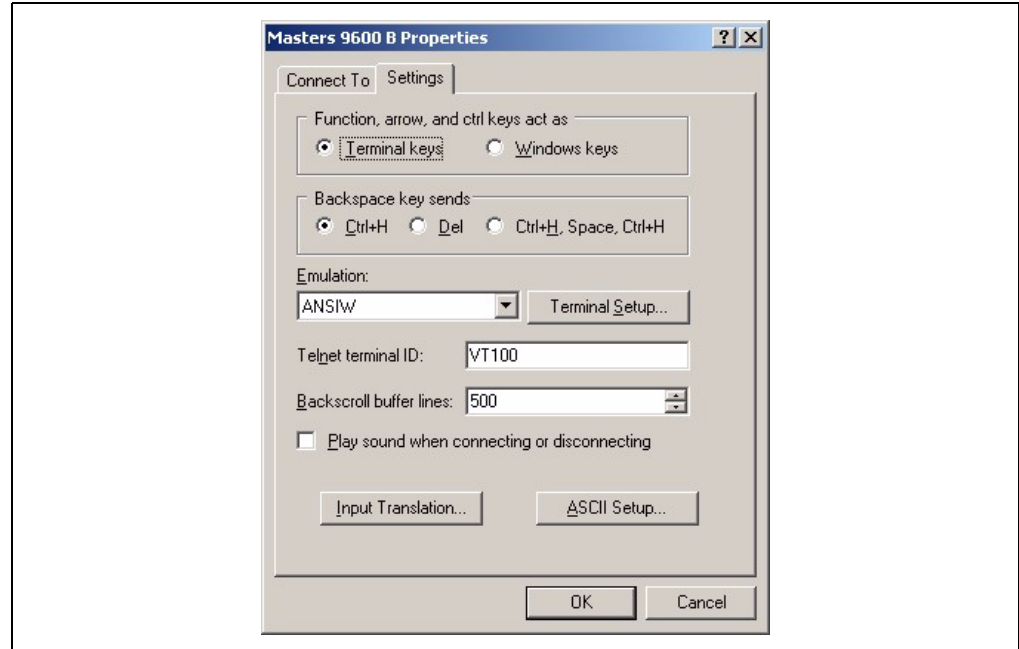

Ensure that your settings match the settings shown. Select the **OK** button. The window in Figure F-4 will again be shown. Select the **Input Translation** button. This will open the Translation Button window (Figure F-6). Click **OK** and close each window. After these “property” windows are closed, you may wish to save each configuration with a name that you can remember (one for COM1 and the other for COM2).

FIGURE F-5: HyperTerminal® PROGRAM ASCII SETUP WINDOW

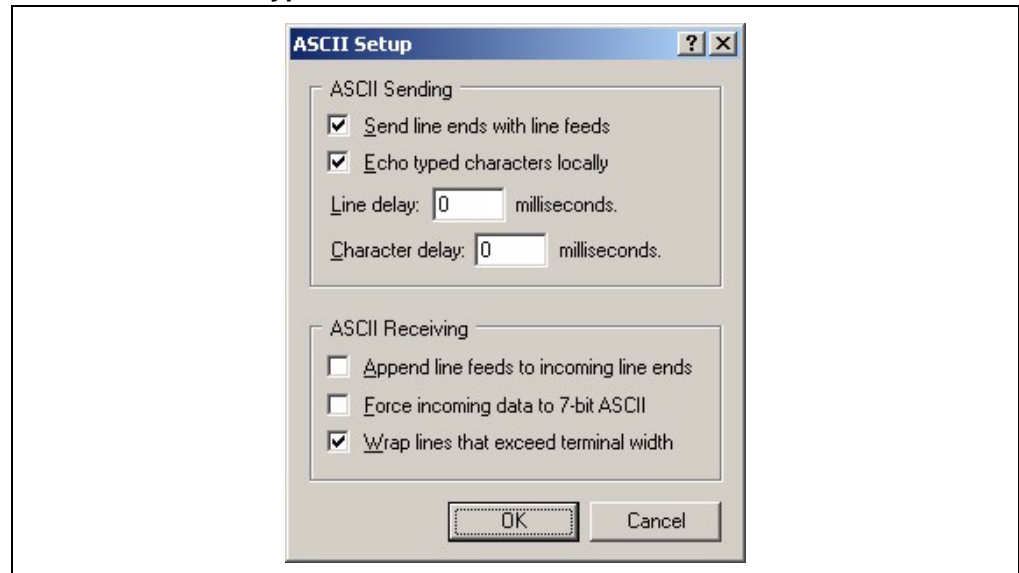

MCP212X Developer's Daughter Board User's Guide

FIGURE F-6: HyperTerminal® PROGRAM INPUT TRANSLATION WINDOW

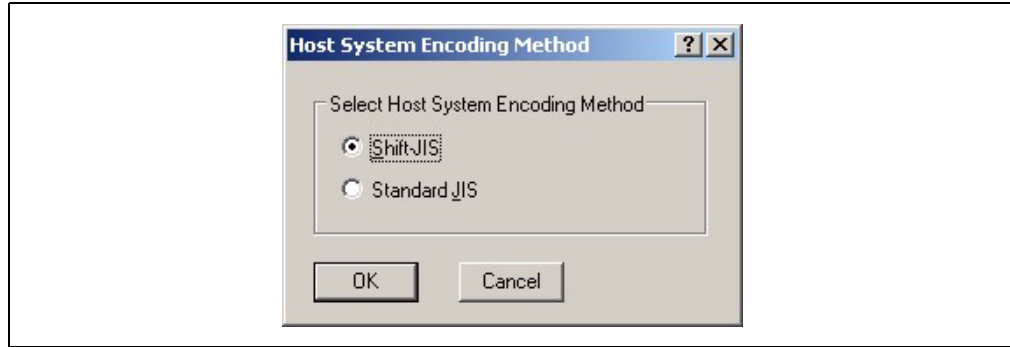

Configuring the HyperTerminal® Program

NOTES:



WORLDWIDE SALES AND SERVICE

AMERICAS

Corporate Office
2355 West Chandler Blvd.
Chandler, AZ 85224-6199
Tel: 480-792-7200
Fax: 480-792-7277
Technical Support:
<http://support.microchip.com>
Web Address:
www.microchip.com

Atlanta

Alpharetta, GA
Tel: 770-640-0034
Fax: 770-640-0307

Boston

Westborough, MA
Tel: 774-760-0087
Fax: 774-760-0088

Chicago

Itasca, IL
Tel: 630-285-0071
Fax: 630-285-0075

Dallas

Addison, TX
Tel: 972-818-7423
Fax: 972-818-2924

Detroit

Farmington Hills, MI
Tel: 248-538-2250
Fax: 248-538-2260

Kokomo

Kokomo, IN
Tel: 765-864-8360
Fax: 765-864-8387

Los Angeles

Mission Viejo, CA
Tel: 949-462-9523
Fax: 949-462-9608

San Jose

Mountain View, CA
Tel: 650-215-1444
Fax: 650-961-0286

Toronto

Mississauga, Ontario,
Canada
Tel: 905-673-0699
Fax: 905-673-6509

ASIA/PACIFIC

Australia - Sydney
Tel: 61-2-9868-6733
Fax: 61-2-9868-6755

China - Beijing
Tel: 86-10-8528-2100
Fax: 86-10-8528-2104

China - Chengdu
Tel: 86-28-8676-6200
Fax: 86-28-8676-6599

China - Fuzhou
Tel: 86-591-8750-3506
Fax: 86-591-8750-3521

China - Hong Kong SAR
Tel: 852-2401-1200
Fax: 852-2401-3431

China - Qingdao
Tel: 86-532-8502-7355
Fax: 86-532-8502-7205

China - Shanghai
Tel: 86-21-5407-5533
Fax: 86-21-5407-5066

China - Shenyang
Tel: 86-24-2334-2829
Fax: 86-24-2334-2393

China - Shenzhen
Tel: 86-755-8203-2660
Fax: 86-755-8203-1760

China - Shunde
Tel: 86-757-2839-5507
Fax: 86-757-2839-5571

China - Wuhan
Tel: 86-27-5980-5300
Fax: 86-27-5980-5118

China - Xian
Tel: 86-29-8833-7250
Fax: 86-29-8833-7256

ASIA/PACIFIC

India - Bangalore
Tel: 91-80-2229-0061
Fax: 91-80-2229-0062

India - New Delhi
Tel: 91-11-5160-8631
Fax: 91-11-5160-8632

India - Pune
Tel: 91-20-2566-1512
Fax: 91-20-2566-1513

Japan - Yokohama
Tel: 81-45-471- 6166
Fax: 81-45-471-6122

Korea - Gumi
Tel: 82-54-473-4301
Fax: 82-54-473-4302

Korea - Seoul
Tel: 82-2-554-7200
Fax: 82-2-558-5932 or
82-2-558-5934

Malaysia - Penang
Tel: 604-646-8870
Fax: 604-646-5086

Philippines - Manila
Tel: 632-634-9065
Fax: 632-634-9069

Singapore
Tel: 65-6334-8870
Fax: 65-6334-8850

Taiwan - Hsin Chu
Tel: 886-3-572-9526
Fax: 886-3-572-6459

Taiwan - Kaohsiung
Tel: 886-7-536-4818
Fax: 886-7-536-4803

Taiwan - Taipei
Tel: 886-2-2500-6610
Fax: 886-2-2508-0102

Thailand - Bangkok
Tel: 66-2-694-1351
Fax: 66-2-694-1350

EUROPE

Austria - Weis
Tel: 43-7242-2244-399
Fax: 43-7242-2244-393

Denmark - Copenhagen
Tel: 45-4450-2828
Fax: 45-4485-2829

France - Paris
Tel: 33-1-69-53-63-20
Fax: 33-1-69-30-90-79

Germany - Munich
Tel: 49-89-627-144-0
Fax: 49-89-627-144-44

Italy - Milan
Tel: 39-0331-742611
Fax: 39-0331-466781

Netherlands - Drunen
Tel: 31-416-690399
Fax: 31-416-690340

Spain - Madrid
Tel: 34-91-352-30-52
Fax: 34-91-352-11-47

UK - Wokingham
Tel: 44-118-921-5869
Fax: 44-118-921-5820



Стандарт Электрон Связь

Мы молодая и активно развивающаяся компания в области поставок электронных компонентов. Мы поставляем электронные компоненты отечественного и импортного производства напрямую от производителей и с крупнейших складов мира.

Благодаря сотрудничеству с мировыми поставщиками мы осуществляем комплексные и плановые поставки широчайшего спектра электронных компонентов.

Собственная эффективная логистика и склад в обеспечивает надежную поставку продукции в точно указанные сроки по всей России.

Мы осуществляем техническую поддержку нашим клиентам и предпродажную проверку качества продукции. На все поставляемые продукты мы предоставляем гарантию .

Осуществляем поставки продукции под контролем ВП МО РФ на предприятия военно-промышленного комплекса России , а также работаем в рамках 275 ФЗ с открытием отдельных счетов в уполномоченном банке. Система менеджмента качества компании соответствует требованиям ГОСТ ISO 9001.

Минимальные сроки поставки, гибкие цены, неограниченный ассортимент и индивидуальный подход к клиентам являются основой для выстраивания долгосрочного и эффективного сотрудничества с предприятиями радиоэлектронной промышленности, предприятиями ВПК и научно-исследовательскими институтами России.

С нами вы становитесь еще успешнее!

Наши контакты:

Телефон: +7 812 627 14 35

Электронная почта: sales@st-electron.ru

Адрес: 198099, Санкт-Петербург,
Промышленная ул, дом № 19, литера Н,
помещение 100-Н Офис 331