

DE10-Standard

USER MANUAL

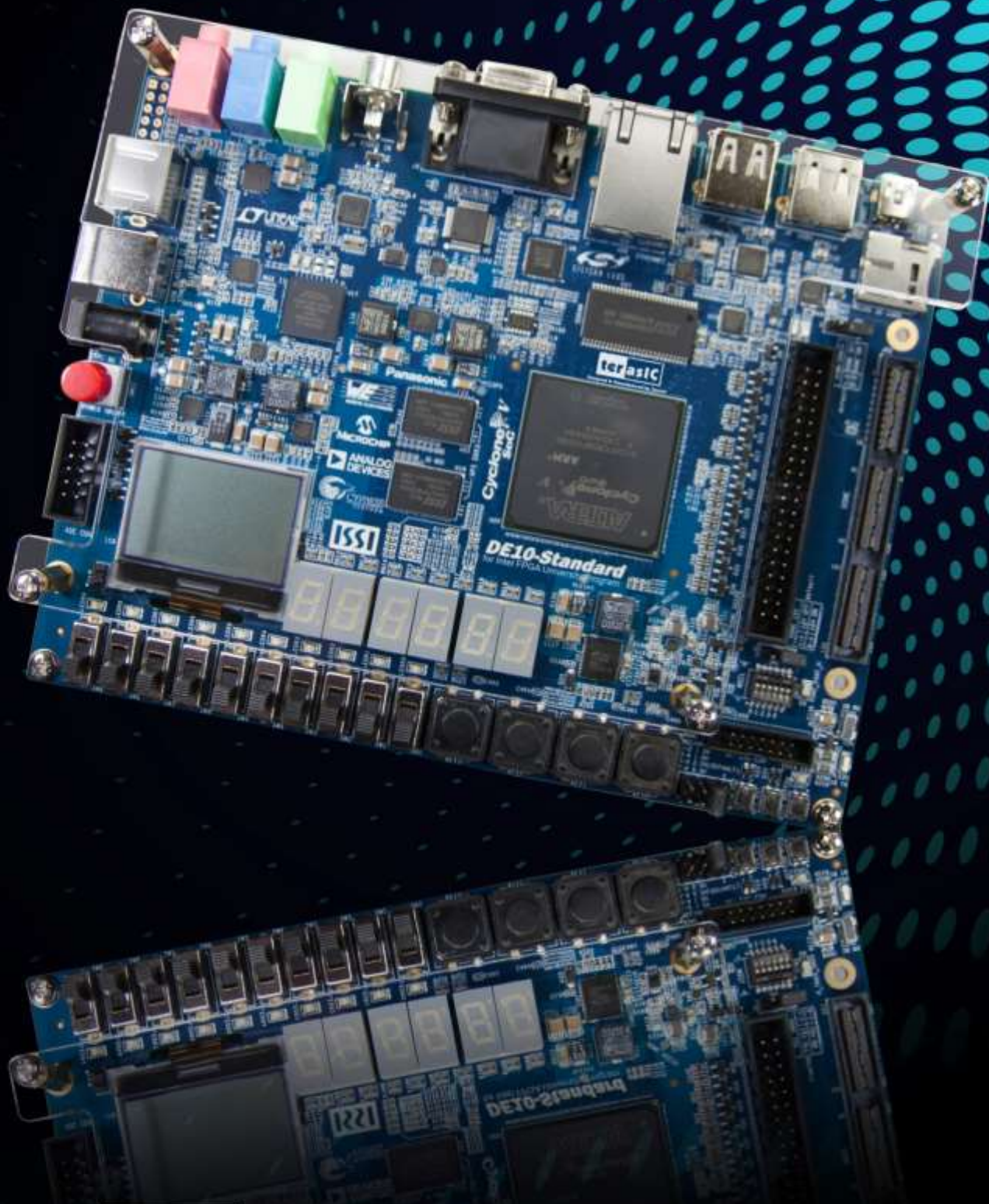

Chapter 1	DE10-Standard Development Kit	4
1.1	Package Contents	4
1.2	DE10-Standard System CD.....	5
1.3	Getting Help.....	5
Chapter 2	Introduction of the DE10-Standard Board	6
2.1	Layout and Components	6
2.2	Block Diagram of the DE10-Standard Board	8
Chapter 3	Using the DE10-Standard Board	11
3.1	Settings of FPGA Configuration Mode.....	11
3.2	Configuration of Cyclone V SoC FPGA on DE10-Standard	12
3.3	Board Status Elements	17
3.4	Board Reset Elements	17
3.5	Clock Circuitry.....	19
3.6	Peripherals Connected to the FPGA	20
3.6.1	User Push-buttons, Switches and LEDs	20
3.6.2	7-segment Displays	23
3.6.3	2x20 GPIO Expansion Header	25
3.6.4	HSMC Connector.....	27
3.6.5	24-bit Audio CODEC	30
3.6.6	I2C Multiplexer	31
3.6.7	VGA Output	32
3.6.8	TV Decoder	35
3.6.9	IR Receiver.....	37
3.6.10	IR Emitter LED	37
3.6.11	SDRAM Memory	38



3.6.12	PS/2 Serial Port	40
3.6.13	A/D Converter and 2x5 Header	41
3.7	Peripherals Connected to Hard Processor System (HPS)	42
3.7.1	User Push-buttons and LEDs	42
3.7.2	Gigabit Ethernet	43
3.7.3	UART to USB	44
3.7.4	DDR3 Memory	45
3.7.5	Micro SD Card Socket	47
3.7.6	2-port USB Host	48
3.7.7	Accelerometer (G-sensor)	49
3.7.8	LTC Connector	49
3.7.9	128x64 Dots LCD	50
Chapter 4	DE10-Standard System Builder	52
4.1	Introduction	52
4.2	Design Flow	53
4.3	Using DE10-Standard System Builder	54
Chapter 5	Examples For FPGA	60
5.1	DE10-Standard Factory Configuration	60
5.2	Audio Recording and Playing	61
5.3	Karaoke Machine	63
5.4	SDRAM Test in Nios II	65
5.5	SDRAM Test in Verilog	68
5.6	TV Box Demonstration	69
5.7	TV Box Demonstration (VIP)	72
5.8	PS/2 Mouse Demonstration	74
5.9	IR Emitter LED and Receiver Demonstration	77
5.10	ADC Reading	82
Chapter 6	Examples for HPS SoC	86
6.1	Hello Program	86



6.2 Users LED and KEY	88
6.3 I2C Interfaced G-sensor	93
6.4 I2C MUX Test.....	96
6.5 SPI Interfaced Graphic LCD.....	98
6.6 Setup USB Wi-Fi Dongle.....	101
6.7 Query Internet Time	104
6.8 ALSA Audio Play.....	105
Chapter 7 Examples for using both HPS SoC and FGPA	108
7.1 Required Background	108
7.2 System Requirements.....	109
7.3 AXI bridges in Intel SoC FPGA.....	109
7.4 GHRD Project.....	110
7.5 Compile and Programming	112
7.6 Develop the C Code	113
Chapter 8 Programming the EPCS Device	119
8.1 Before Programming Begins.....	119
8.2 Convert .SOF File to .JIC File	119
8.3 Write JIC File into the EPCS Device	124
8.4 Erase the EPCS Device.....	125
Chapter 9 Linux BSP	127
9.1 Use Linux BSP.....	127
9.2 Linux Console BSP.....	128
9.3 Linux LXDE Desktop BSP	130
9.4 OpenCL BSP.....	131
Chapter 10 Appendix.....	133
10.1 Revision History	133
10.2 Copyright Statement	133



Chapter 1

DE10-Standard Development Kit

The DE10-Standard Development Kit presents a robust hardware design platform built around the Intel System-on-Chip (SoC) FPGA, which combines the latest dual-core Cortex-A9 embedded cores with industry-leading programmable logic for ultimate design flexibility. Users can now leverage the power of tremendous re-configurability paired with a high-performance, low-power processor system. Intel's SoC integrates an ARM-based hard processor system (HPS) consisting of processor, peripherals and memory interfaces tied seamlessly with the FPGA fabric using a high-bandwidth interconnect backbone. The DE10-Standard development board is equipped with high-speed DDR3 memory, video and audio capabilities, Ethernet networking, and much more that promise many exciting applications.

The DE10-Standard Development Kit contains all the tools needed to use the board in conjunction with a computer that runs the Microsoft Windows XP or later.

1.1 Package Contents



Figure 1-1 The DE10-Standard package contents

The DE10-Standard package includes:

- The DE10-Standard development board
- DE10-Standard Quick Start Guide
- USB cable (Type A to B) for FPGA programming and control
- USB cable (Type A to Mini-B) for UART control
- 12V DC power adapter

1.2 DE10-Standard System CD

The DE10-Standard System CD contains all the documents and supporting materials associated with DE10-Standard, including the user manual, system builder, reference designs, and device datasheets. Users can download this system CD from the link: <http://de10-standard.terasic.com/cd/>.

The developers can create their Quartus project based on the **golden_top** Quartus project included in this CD. The **golde_top** Quartus project is placed in the folder: Demonstration/FPGA/golden_top. Additionally, developers can use the System Builder software utility to create their Quartus project. A detailed introduction of the software is given in **Chapter 4 DE10-Standard System Builder**.

1.3 Getting Help

Here are the addresses where you can get help if you encounter any problems:

- Terasic Technologies
- 9F., No.176, Sec.2, Gongdao 5th Rd, East Dist, Hsinchu City, 30070. Taiwan

Email: support@terasic.com

Tel.: +886-3-575-0880

Website: de10-standard.terasic.com



Chapter 2

Introduction of the DE10-Standard Board

This chapter provides an introduction to the features and design characteristics of the board.

2.1 Layout and Components

Figure 2-1 shows a photograph of the board. It depicts the layout of the board and indicates the location of the connectors and key components.

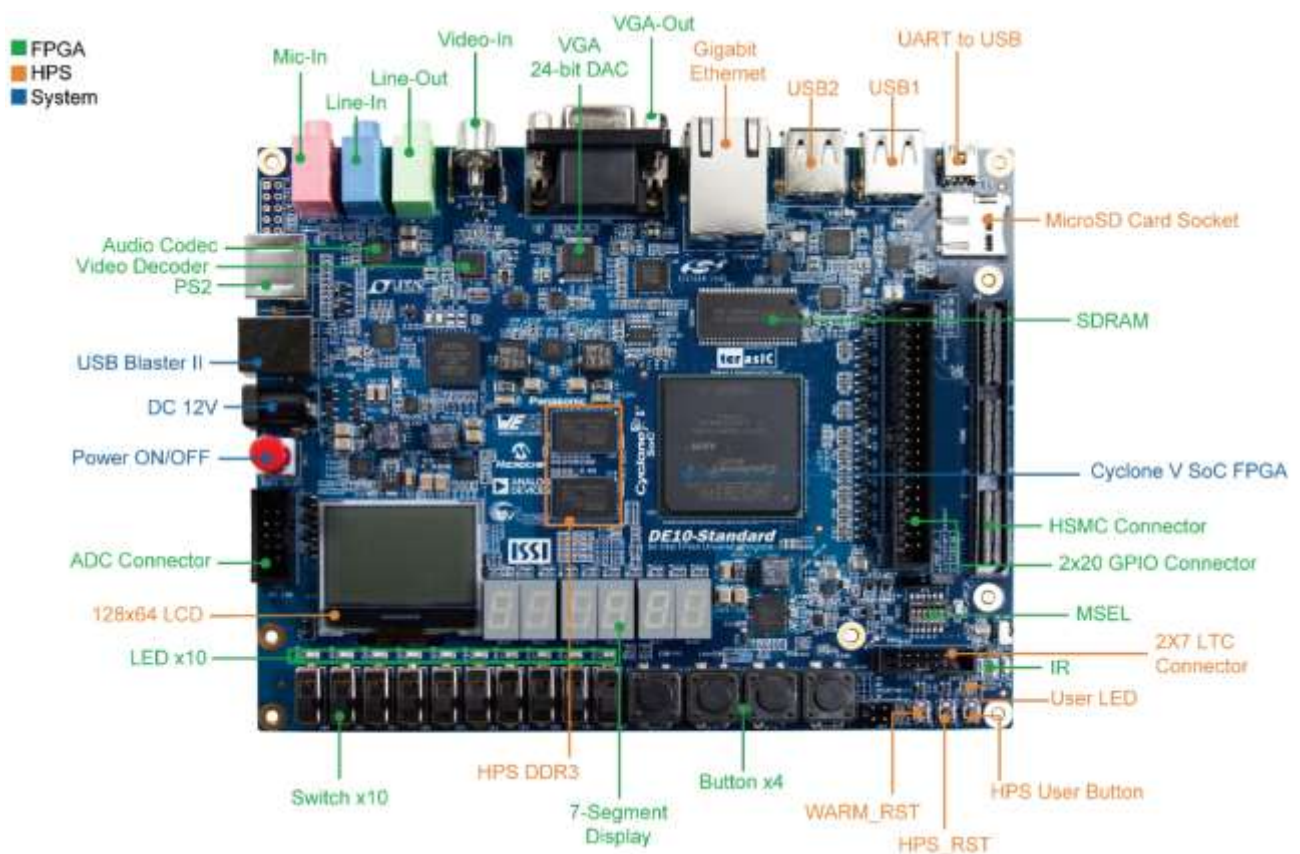

Figure 2-1 DE10-Standard development board (top view)



Figure 2-2 DE10-Standard development board (bottom view)

The DE10-Standard board has many features that allow users to implement a wide range of designed circuits, from simple circuits to various multimedia projects.

The following hardware is provided on the board:

■ FPGA

- Intel Cyclone® V SE 5CSXFC6D6F31C6N device
- Serial configuration device – EPCS128
- USB-Blaster II onboard for programming; JTAG Mode
- 64MB SDRAM (16-bit data bus)
- 4 push-buttons
- 10 slide switches
- 10 red user LEDs
- Six 7-segment displays
- Four 50MHz clock sources from the clock generator
- 24-bit CD-quality audio CODEC with line-in, line-out, and microphone-in jacks
- VGA DAC (8-bit high-speed triple DACs) with VGA-out connector
- TV decoder (NTSC/PAL/SECAM) and TV-in connector
- PS/2 mouse/keyboard connector
- IR receiver and IR emitter
- One HSMC with Configurable I/O standard 1.5/1.8/2.5/3.3
- One 40-pin expansion header with diode protection
- A/D converter, 4-pin SPI interface with FPGA

■ HPS (Hard Processor System)

- 925MHz Dual-core ARM Cortex-A9 MPCore processor
- 1GB DDR3 SDRAM (32-bit data bus)
- 1 Gigabit Ethernet PHY with RJ45 connector
- 2-port USB Host, normal Type-A USB connector
- Micro SD card socket
- Accelerometer (I2C interface + interrupt)
- UART to USB, USB Mini-B connector
- Warm reset button and cold reset button
- One user button and one user LED
- LTC 2x7 expansion header
- 128x64 dots LCD Module with Backlight

2.2 Block Diagram of the DE10-Standard Board

Figure 2-3 is the block diagram of the board. All the connections are established through the Cyclone V SoC FPGA device to provide maximum flexibility for users. Users can configure the FPGA to implement any system design.

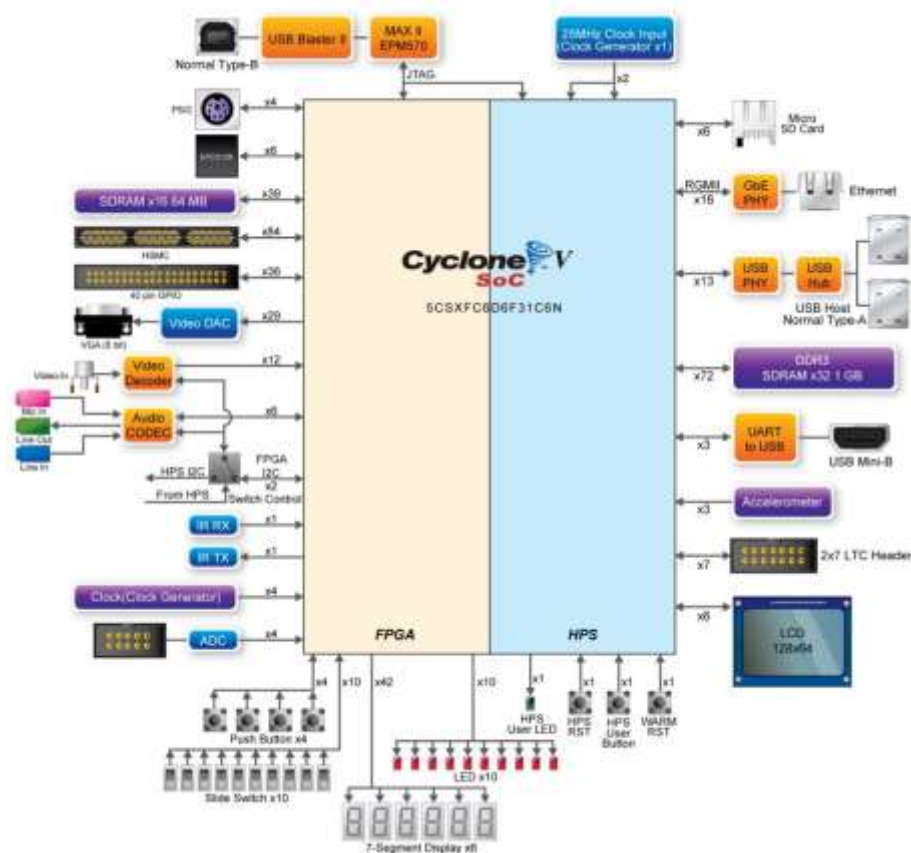

Figure 2-3 Block diagram of DE10-Standard

Detailed information about **Figure 2-3** are listed below.

FPGA Device

- Cyclone V SoC 5CSXFC6D6F31C6N Device
- Dual-core ARM Cortex-A9 (HPS)
- 110K programmable logic elements
- 5,761 Kbits embedded memory
- 6 fractional PLLs
- 2 hard memory controllers

Configuration and Debug

- Quad serial configuration device – EPCS128 on FPGA
- Onboard USB-Blaster II (normal type B USB connector)

Memory Device

- 64MB (32Mx16) SDRAM on FPGA
- 1GB (2x256Mx16) DDR3 SDRAM on HPS
- Micro SD card socket on HPS

Communication

- Two port USB 2.0 Host (ULPI interface with USB type A connector)
- UART to USB (USB Mini-B connector)
- 10/100/1000 Ethernet
- PS/2 mouse/keyboard
- IR emitter/receiver
- I2C multiplexer

Connectors

- One HSMC (Configurable I/O standards 1.5/1.8/2.5/3.3V)
- One 40-pin expansion headers
- One 10-pin ADC input header
- One LTC connector (one Serial Peripheral Interface (SPI) Master, one I2C and one GPIO interface)

Display

- 24-bit VGA DAC
- 128x64 dots LCD Module with Backlight

Audio

- 24-bit CODEC, Line-in, Line-out, and microphone-in jacks

Video Input



- TV decoder (NTSC/PAL/SECAM) and TV-in connector

ADC

- Interface: SPI
- Fast throughput rate: 500 KSPS
- Channel number: 8
- Resolution: 12-bit
- Analog input range : 0 ~ 4.096

Switches, Buttons, and Indicators

- 5 user Keys (FPGA x4, HPS x1)
- 10 user switches (FPGA x10)
- 11 user LEDs (FPGA x10, HPS x 1)
- 2 HPS reset buttons (HPS_RESET_n and HPS_WARM_RST_n)
- Six 7-segment displays

Sensors

- G-Sensor on HPS

Power

- 12V DC input

Chapter 3

Using the

DE10-Standard Board

This chapter provides an instruction to use the board and describes the peripherals.

3.1 Settings of FPGA Configuration Mode

When the DE10-Standard board is powered on, the FPGA can be configured from EPCS or HPS. The MSEL[4:0] pins are used to select the configuration scheme. It is implemented as a 6-pin DIP switch SW10 on the DE10-Standard board, as shown in **Figure 3-1**.

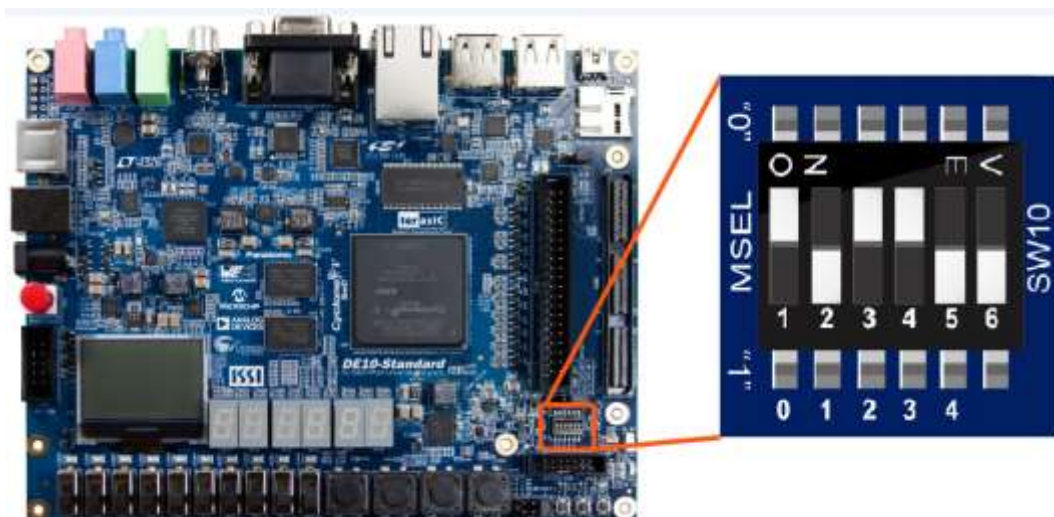

Figure 3-1 DIP switch (SW10) setting of Active Serial (AS) mode on DE10-Standard board

Table 3-1 shows the relation between MSEL[4:0] and DIP switch (SW10).

Table 3-1 FPGA Configuration Mode Switch (SW10)

Board Reference	Signal Name	Description	Default AS Mode
SW10.1	MSEL0	Use these pins to set the FPGA Configuration scheme	OFF ("1")
SW10.2	MSEL1		ON ("0")

SW10.3	MSEL2		ON ("0")
SW10.4	MSEL3		OFF ("1")
SW10.5	MSEL4		ON ("0")
SW10.6	N/A	N/A	N/A

Figure 3-1 shows MSEL[4:0] setting of AS mode, which is also the default setting on DE10-Standard. When the board is powered on, the FPGA is configured from EPCS, which is pre-programmed with the default code. If developers wish to reconfigure FPGA from an application software running on Linux, the MSEL[4:0] needs to be set to "01010" before the programming process begins.

Table 3-2 MSEL Pin Settings for FPGA Configure of DE10-Standard

<i>MSEL[4:0]</i>	<i>Configure Scheme</i>	<i>Description</i>
10010	AS	FPGA configured from EPCS (default)
01010	FPPx32	FPGA configured from HPS software: Linux

3.2 Configuration of Cyclone V SoC FPGA on DE10-Standard

There are two types of programming method supported by DE10-Standard:

1. JTAG programming: It is named after the IEEE standards Joint Test Action Group.

The configuration bitstream is downloaded directly into the Cyclone V SoC FPGA. The FPGA will retain its current status as long as the power keeps applying to the board; the configuration information will be lost when the power is off.

2. AS programming: The other programming method is Active Serial configuration.

The configuration bitstream is downloaded into the quad serial configuration device (EPCS128), which provides non-volatile storage for the bit stream. The information is retained within EPCS128 even if the DE10-Standard board is turned off. When the board is powered on, the configuration data in the EPCS128 device is automatically loaded into the Cyclone V SoC FPGA.

■ JTAG Chain on DE10-Standard Board

The FPGA device can be configured through JTAG interface on DE10-Standard board, but the JTAG chain must form a closed loop, which allows Quartus II programmer to detect FPGA device. **Figure 3-2** illustrates the JTAG chain on DE10-Standard board.

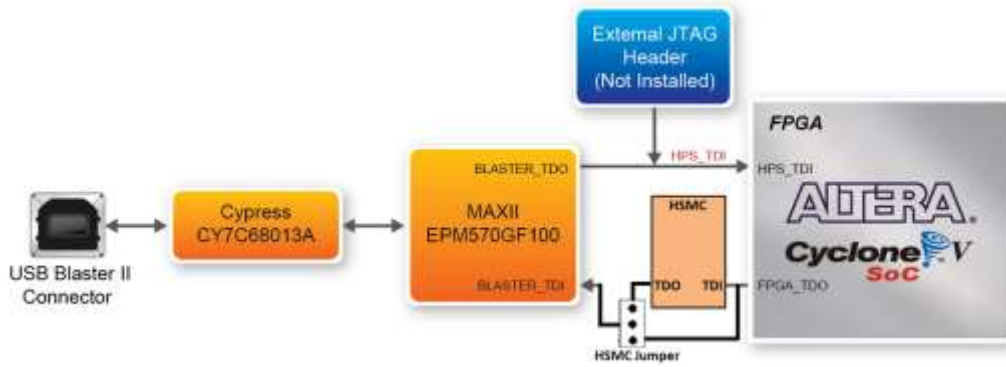

Figure 3-2 Path of the JTAG chain

■ Configure the FPGA in JTAG Mode

There are two devices (FPGA and HPS) on the JTAG chain. The following shows how the FPGA is programmed in JTAG mode step by step.

1. Open the Quartus II programmer and click “Auto Detect”, as circled in [Figure 3-3](#)

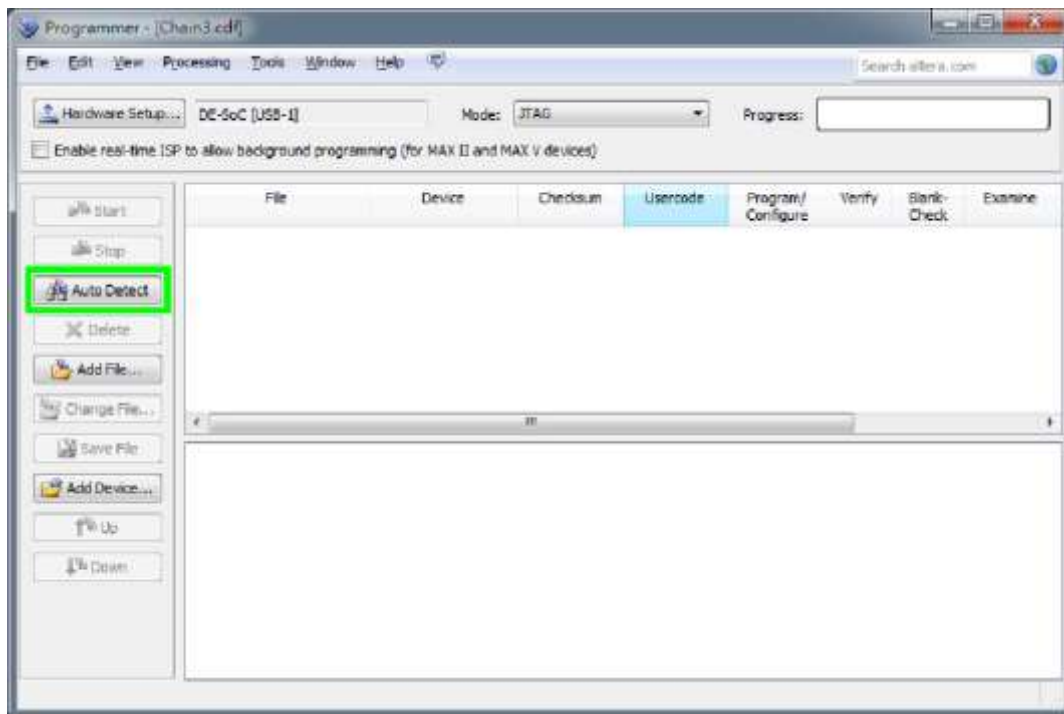

Figure 3-3 Detect FPGA device in JTAG mode

2. Select detected device associated with the board, as circled in [Figure 3-4](#).

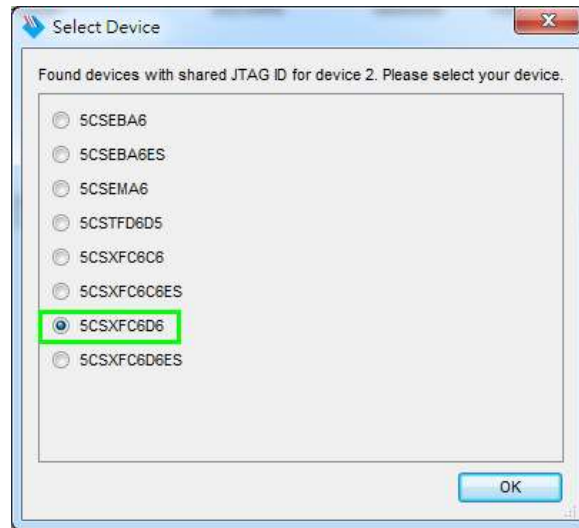

Figure 3-4 Select 5CSXFC6D6 device

- Both FPGA and HPS are detected, as shown in Figure 3-5.

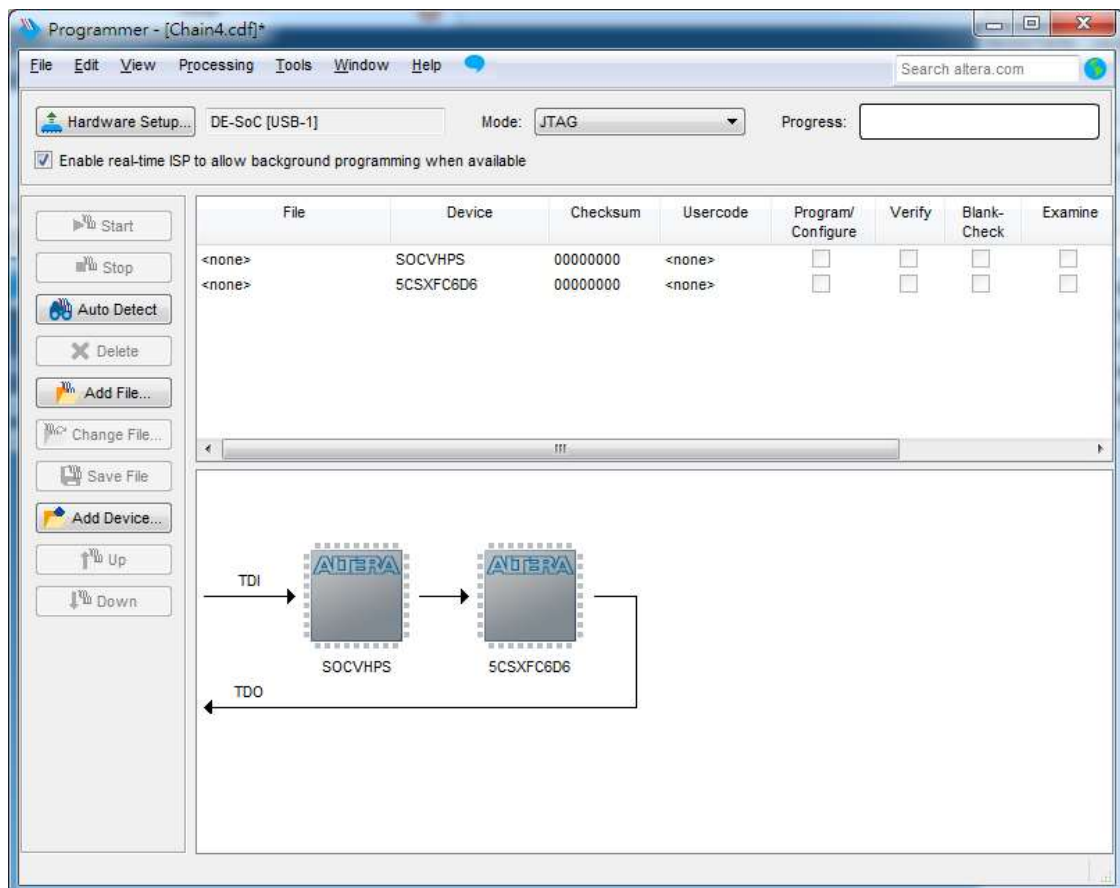

Figure 3-5 FPGA and HPS detected in Quartus programmer

- Right click on the FPGA device and open the .sof file to be programmed, as highlighted in Figure 3-6.

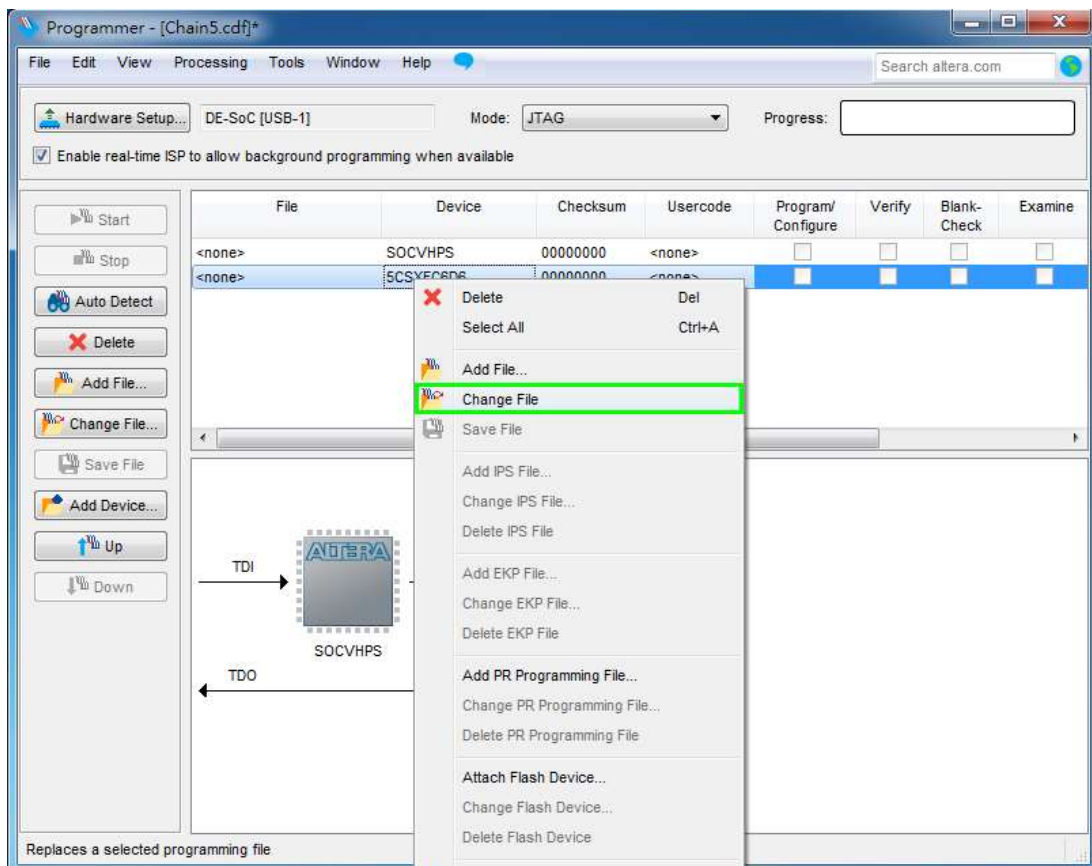

Figure 3-6 Open the .sof file to be programmed into the FPGA device

5. Select the .sof file to be programmed, as shown in **Figure 3-7**.

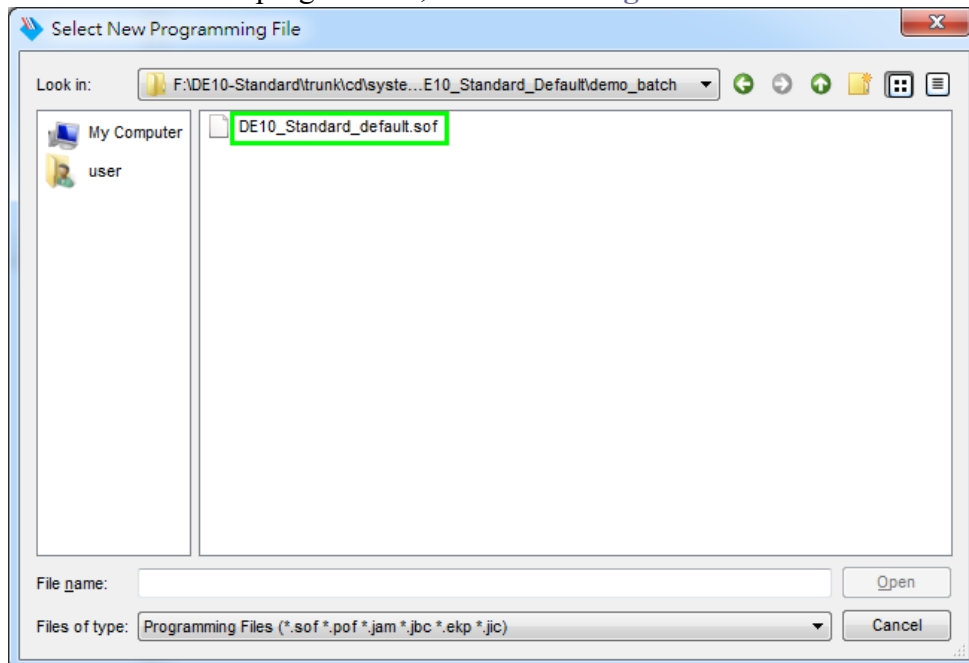

Figure 3-7 Select the .sof file to be programmed into the FPGA device

6. Click “Program/Configure” checkbox and then click “Start” button to download the .sof file

into the FPGA device, as shown in **Figure 3-8**.

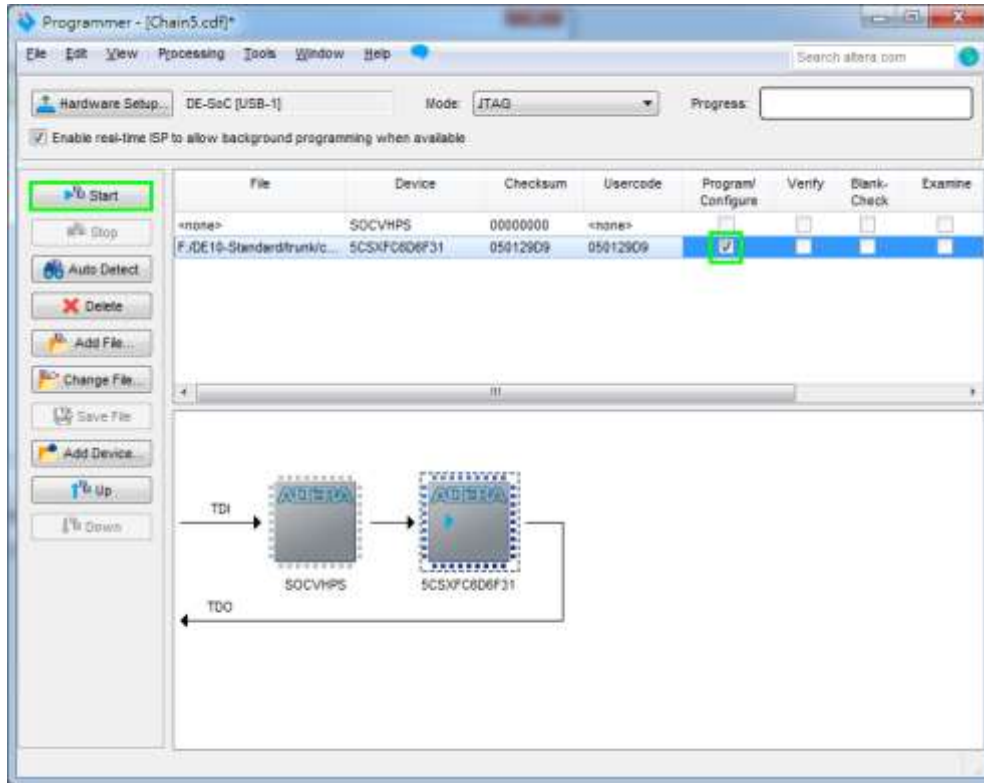

Figure 3-8 Program .sof file into the FPGA device

■ Configure the FPGA in AS Mode

- The DE10-Standard board uses a quad serial configuration device (EPCS128) to store configuration data for the Cyclone V SoC FPGA. This configuration data is automatically loaded from the quad serial configuration device chip into the FPGA when the board is powered up.
- Users need to use Serial Flash Loader (SFL) to program the quad serial configuration device via JTAG interface. The FPGA-based SFL is a soft intellectual property (IP) core within the FPGA that bridge the JTAG and Flash interfaces. The SFL Megafunction is available in Quartus II. **Figure 3-9** shows the programming method when adopting SFL solution.
- Please refer to Chapter 9: Steps of Programming the Quad Serial Configuration Device for the basic programming instruction on the serial configuration device.



3.3 Board Status Elements

In addition to the 10 LEDs that FPGA device can control, there are 5 indicators which can indicate the board status (See **Figure 3-10**), please refer the details in **Table 3-3**.



Figure 3-10 LED Indicators on DE10-Standard

Table 3-3 LED Indicators

Board Reference	LED Name	Description
D14	12-V Power	Illuminates when 12V power is active.
TXD	UART TXD	Illuminates when data is transferred from FT232R to USB Host.
RXD	UART RXD	Illuminates when data is transferred from USB Host to FT232R.
D5	JTAG_RX	Reserved
D4	JTAG_TX	

3.4 Board Reset Elements

There are two HPS reset buttons on DE10-Standard, HPS (cold) reset and HPS warm reset, as shown in **Figure 3-11**. **Table 3-4** describes the purpose of these two HPS reset buttons. **Figure 3-12** is the reset tree for DE10-Standard.

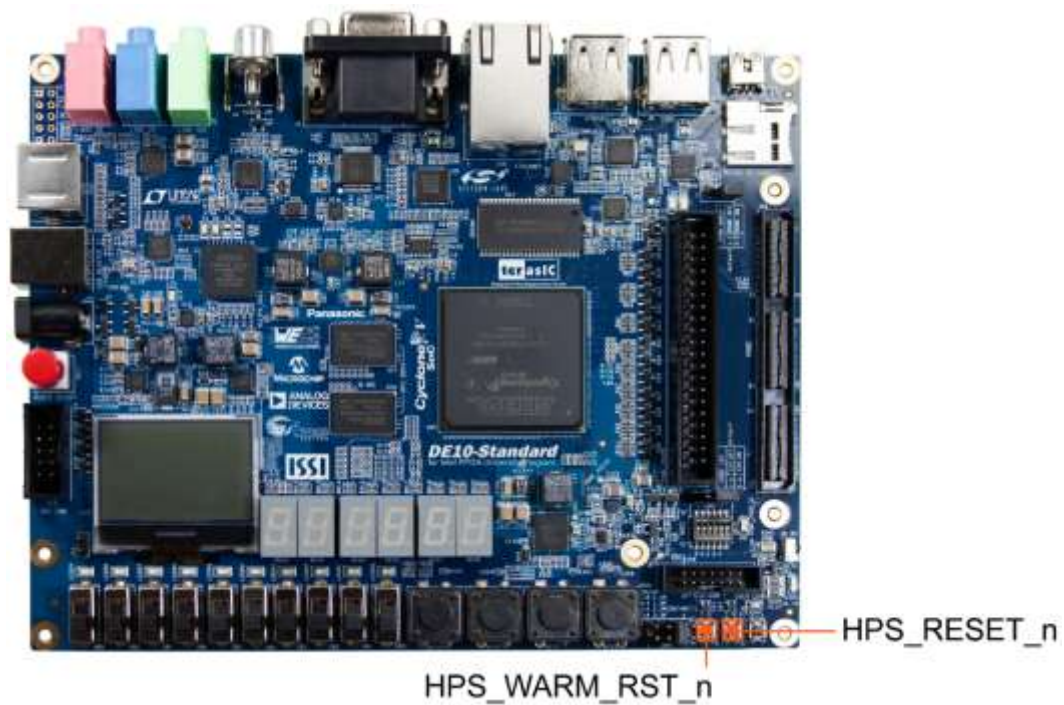

Figure 3-11 HPS cold reset and warm reset buttons on DE10-Standard

Table 3-4 Description of Two HPS Reset Buttons on DE10-Standard

<i>Board Reference</i>	<i>Signal Name</i>	<i>Description</i>
KEY5	HPS_RESET_N	Cold reset to the HPS, Ethernet PHY and USB host device. Active low input which resets all HPS logics that can be reset.
KEY7	HPS_WARM_RST_N	Warm reset to the HPS block. Active low input affects the system reset domain for debug purpose.

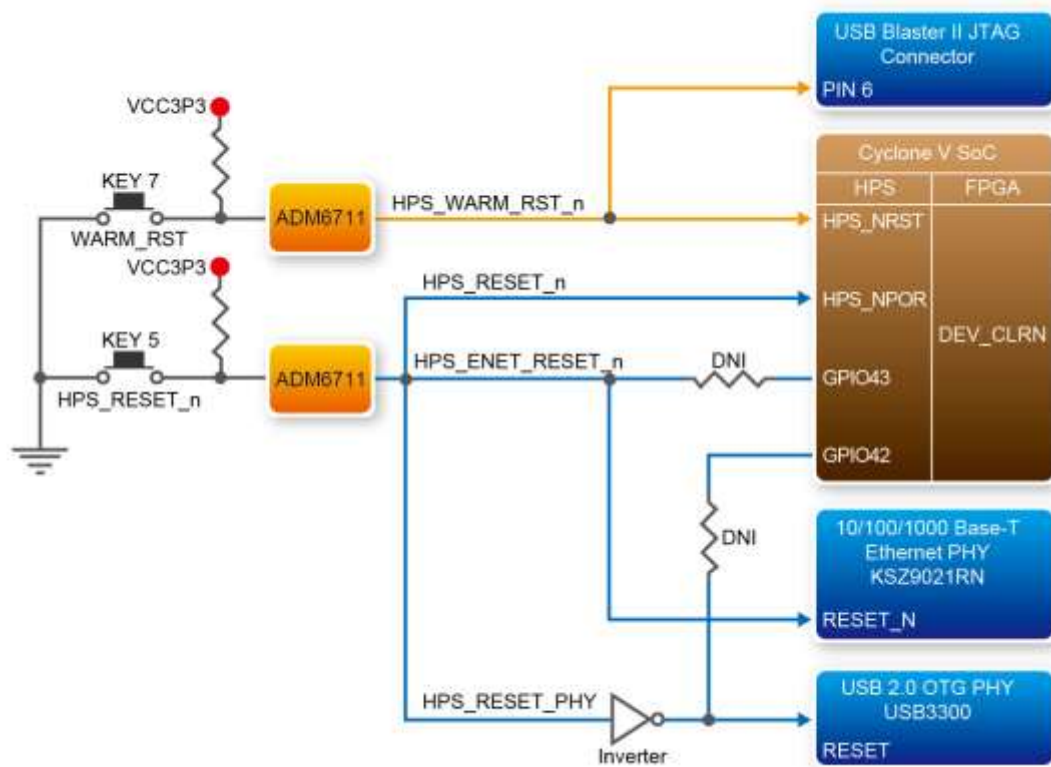

Figure 3-12 HPS reset tree on DE10-Standard board

3.5 Clock Circuitry

Figure 3-13 shows the default frequency of all external clocks to the Cyclone V SoC FPGA. A clock generator is used to distribute clock signals with low jitter. The four 50MHz clock signals connected to the FPGA are used as clock sources for user logic. One 25MHz clock signal is connected to two HPS clock inputs, and the other one is connected to the clock input of Gigabit Ethernet Transceiver. Two 24MHz clock signals are connected to the clock inputs of USB Host/OTG PHY and USB hub controller. The associated pin assignment for clock inputs to FPGA I/O pins is listed in Table 3-5.

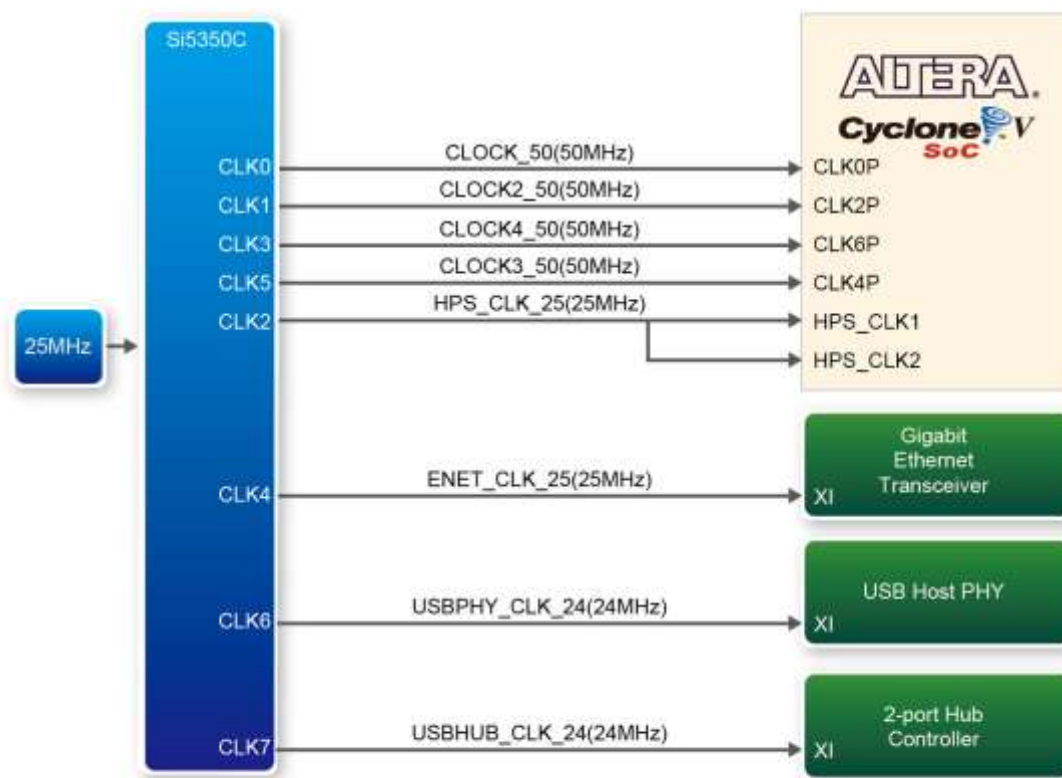

Figure 3-13 Block diagram of the clock distribution on DE10-Standard

Table 3-5 Pin Assignment of Clock Inputs

Signal Name	FPGA Pin No.	Description	I/O Standard
CLOCK_50	PIN_AF14	50 MHz clock input	3.3V
CLOCK2_50	PIN_AA16	50 MHz clock input	3.3V
CLOCK3_50	PIN_Y26	50 MHz clock input	3.3V
CLOCK4_50	PIN_K14	50 MHz clock input	3.3V
HPS_CLOCK1_25	PIN_D25	25 MHz clock input	3.3V
HPS_CLOCK2_25	PIN_F25	25 MHz clock input	3.3V

3.6 Peripherals Connected to the FPGA

This section describes the interfaces connected to the FPGA. Users can control or monitor different interfaces with user logic from the FPGA.

3.6.1 User Push-buttons, Switches and LEDs

The board has four push-buttons connected to the FPGA, as shown in [Figure 3-14](#) Connections between the push-buttons and the Cyclone V SoC FPGA. Schmitt trigger circuit is implemented and act as switch debounce in [Figure 3-15](#) for the push-buttons connected. The four push-buttons

named KEY0, KEY1, KEY2, and KEY3 coming out of the Schmitt trigger device are connected directly to the Cyclone V SoC FPGA. The push-button generates a low logic level when it is pressed (Active low). Since the push-buttons are debounced, they can be used as reset inputs in a circuit.

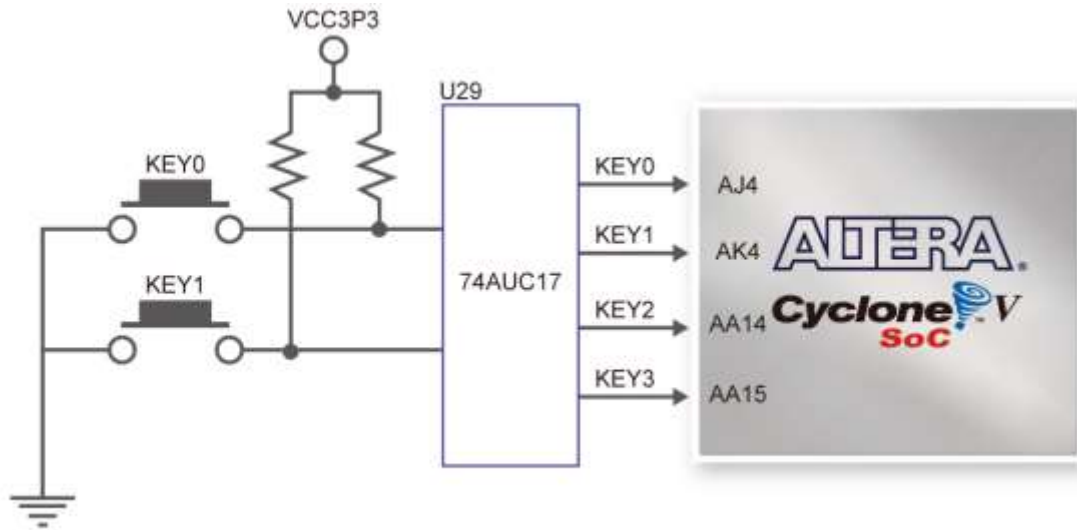

Figure 3-14 Connections between the push-buttons and the Cyclone V SoC FPGA

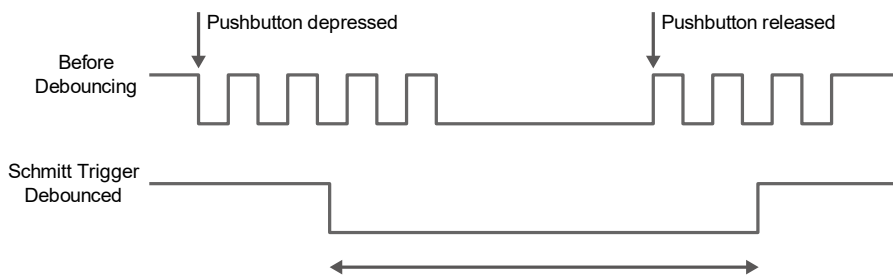

Figure 3-15 Switch debouncing

There are ten slide switches connected to the FPGA, as shown in **Figure 3-16**. These switches are not debounced and to be used as level-sensitive data inputs to a circuit. Each switch is connected directly and individually to the FPGA. When the switch is set to the DOWN position (towards the edge of the board), it generates a low logic level to the FPGA. When the switch is set to the UP position, a high logic level is generated to the FPGA



Figure 3-16 Connections between the slide switches and the Cyclone V SoC FPGA

There are also ten user-controllable LEDs connected to the FPGA. Each LED is driven directly and individually by the Cyclone V SoC FPGA; driving its associated pin to a high logic level or low level to turn the LED on or off, respectively. **Figure 3-17** shows the connections between LEDs and Cyclone V SoC FPGA. **Table 3-6**, **Table 3-7** and **Table 3-8** list the pin assignment of user push-buttons, switches, and LEDs.



Figure 3-17 Connections between the LEDs and the Cyclone V SoC FPGA

Table 3-6 Pin Assignment of Slide Switches

<i>Signal Name</i>	<i>FPGA Pin No.</i>	<i>Description</i>	<i>I/O Standard</i>
SW[0]	PIN_AB30	Slide Switch[0]	Depend on JP3
SW[1]	PIN_Y27	Slide Switch[1]	Depend on JP3
SW[2]	PIN_AB28	Slide Switch[2]	Depend on JP3
SW[3]	PIN_AC30	Slide Switch[3]	Depend on JP3
SW[4]	PIN_W25	Slide Switch[4]	Depend on JP3
SW[5]	PIN_V25	Slide Switch[5]	Depend on JP3
SW[6]	PIN_AC28	Slide Switch[6]	Depend on JP3
SW[7]	PIN_AD30	Slide Switch[7]	Depend on JP3
SW[8]	PIN_AC29	Slide Switch[8]	Depend on JP3
SW[9]	PIN_AA30	Slide Switch[9]	Depend on JP3

Table 3-7 Pin Assignment of Push-buttons

<i>Signal Name</i>	<i>FPGA Pin No.</i>	<i>Description</i>	<i>I/O Standard</i>
KEY[0]	PIN_AJ4	Push-button[0]	3.3V
KEY[1]	PIN_AK4	Push-button[1]	3.3V
KEY[2]	PIN_AA14	Push-button[2]	3.3V
KEY[3]	PIN_AA15	Push-button[3]	3.3V

Table 3-8 Pin Assignment of LEDs

<i>Signal Name</i>	<i>FPGA Pin No.</i>	<i>Description</i>	<i>I/O Standard</i>
LEDR[0]	PIN_AA24	LED [0]	3.3V
LEDR[1]	PIN_AB23	LED [1]	3.3V
LEDR[2]	PIN_AC23	LED [2]	3.3V
LEDR[3]	PIN_AD24	LED [3]	3.3V
LEDR[4]	PIN_AG25	LED [4]	3.3V
LEDR[5]	PIN_AF25	LED [5]	3.3V
LEDR[6]	PIN_AE24	LED [6]	3.3V
LEDR[7]	PIN_AF24	LED [7]	3.3V
LEDR[8]	PIN_AB22	LED [8]	3.3V
LEDR[9]	PIN_AC22	LED [9]	3.3V

3.6.2 7-segment Displays

The DE10-Standard board has six 7-segment displays. These displays are paired to display numbers in various sizes. **Figure 3-18** shows the connection of seven segments (common anode) to pins on Cyclone V SoC FPGA. The segment can be turned on or off by applying a low logic level or high logic level from the FPGA, respectively.

Each segment in a display is indexed from 0 to 6, with corresponding positions given in **Figure 3-18**. **Table 3-9** shows the pin assignment of FPGA to the 7-segment displays.

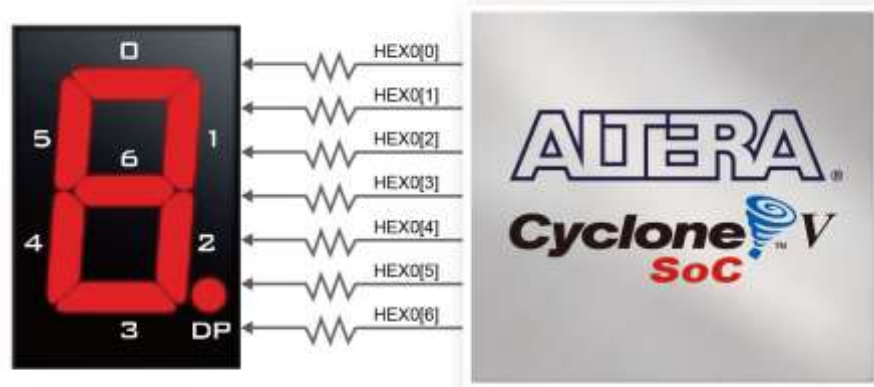

Figure 3-18 Connections between the 7-segment display HEX0 and the Cyclone V SoC FPGA

Table 3-9 Pin Assignment of 7-segment Displays

Signal Name	FPGA Pin No.	Description	I/O Standard
HEX0[0]	PIN_W17	Seven Segment Digit 0[0]	3.3V
HEX0[1]	PIN_V18	Seven Segment Digit 0[1]	3.3V
HEX0[2]	PIN_AG17	Seven Segment Digit 0[2]	3.3V
HEX0[3]	PIN_AG16	Seven Segment Digit 0[3]	3.3V
HEX0[4]	PIN_AH17	Seven Segment Digit 0[4]	3.3V
HEX0[5]	PIN_AG18	Seven Segment Digit 0[5]	3.3V
HEX0[6]	PIN_AH18	Seven Segment Digit 0[6]	3.3V
HEX1[0]	PIN_AF16	Seven Segment Digit 1[0]	3.3V
HEX1[1]	PIN_V16	Seven Segment Digit 1[1]	3.3V
HEX1[2]	PIN_AE16	Seven Segment Digit 1[2]	3.3V
HEX1[3]	PIN_AD17	Seven Segment Digit 1[3]	3.3V
HEX1[4]	PIN_AE18	Seven Segment Digit 1[4]	3.3V
HEX1[5]	PIN_AE17	Seven Segment Digit 1[5]	3.3V
HEX1[6]	PIN_V17	Seven Segment Digit 1[6]	3.3V
HEX2[0]	PIN_AA21	Seven Segment Digit 2[0]	3.3V
HEX2[1]	PIN_AB17	Seven Segment Digit 2[1]	3.3V
HEX2[2]	PIN_AA18	Seven Segment Digit 2[2]	3.3V
HEX2[3]	PIN_Y17	Seven Segment Digit 2[3]	3.3V
HEX2[4]	PIN_Y18	Seven Segment Digit 2[4]	3.3V
HEX2[5]	PIN_AF18	Seven Segment Digit 2[5]	3.3V
HEX2[6]	PIN_W16	Seven Segment Digit 2[6]	3.3V
HEX3[0]	PIN_Y19	Seven Segment Digit 3[0]	3.3V
HEX3[1]	PIN_W19	Seven Segment Digit 3[1]	3.3V
HEX3[2]	PIN_AD19	Seven Segment Digit 3[2]	3.3V
HEX3[3]	PIN_AA20	Seven Segment Digit 3[3]	3.3V
HEX3[4]	PIN_AC20	Seven Segment Digit 3[4]	3.3V
HEX3[5]	PIN_AA19	Seven Segment Digit 3[5]	3.3V
HEX3[6]	PIN_AD20	Seven Segment Digit 3[6]	3.3V
HEX4[0]	PIN_AD21	Seven Segment Digit 4[0]	3.3V

HEX4[1]	PIN_AG22	Seven Segment Digit 4[1]	3.3V
HEX4[2]	PIN_AE22	Seven Segment Digit 4[2]	3.3V
HEX4[3]	PIN_AE23	Seven Segment Digit 4[3]	3.3V
HEX4[4]	PIN_AG23	Seven Segment Digit 4[4]	3.3V
HEX4[5]	PIN_AF23	Seven Segment Digit 4[5]	3.3V
HEX4[6]	PIN_AH22	Seven Segment Digit 4[6]	3.3V
HEX5[0]	PIN_AF21	Seven Segment Digit 5[0]	3.3V
HEX5[1]	PIN_AG21	Seven Segment Digit 5[1]	3.3V
HEX5[2]	PIN_AF20	Seven Segment Digit 5[2]	3.3V
HEX5[3]	PIN_AG20	Seven Segment Digit 5[3]	3.3V
HEX5[4]	PIN_AE19	Seven Segment Digit 5[4]	3.3V
HEX5[5]	PIN_AF19	Seven Segment Digit 5[5]	3.3V
HEX5[6]	PIN_AB21	Seven Segment Digit 5[6]	3.3V

3.6.3 2x20 GPIO Expansion Header

The board has one 40-pin expansion headers. The header has 36 user pins connected directly to the Cyclone V SoC FPGA. It also comes with DC +5V (VCC5), DC +3.3V (VCC3P3), and two GND pins. The maximum power consumption allowed for a daughter card connected to one GPIO ports is shown in [Table 3-10](#).

Table 3-10 Voltage and Max. Current Limit of Expansion Header(s)

<i>Supplied Voltage</i>	<i>Max. Current Limit</i>
5V	1A
3.3V	1.5A

Each pin on the expansion headers is connected to two diodes and a resistor for protection against high or low voltage level. [Figure 3-19](#) shows the protection circuitry applied to all 36 data pins. [Table 3-11](#) shows the pin assignment of the GPIO header.

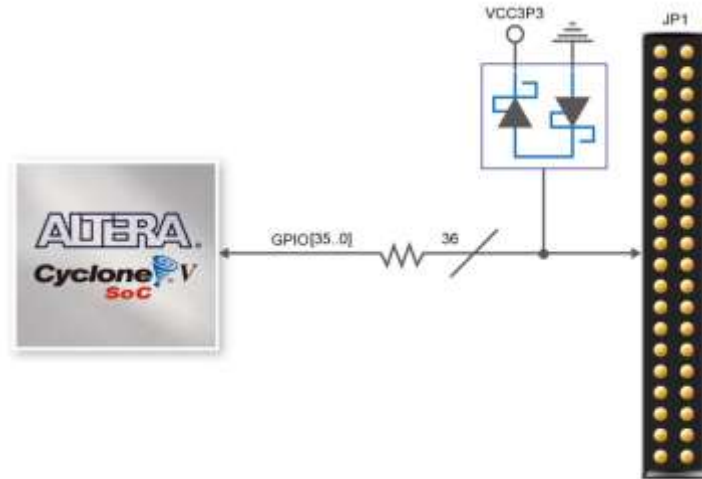

Figure 3-19 Connections between the GPIO header and Cyclone V SoC FPGA

Table 3-11 Pin Assignment of Expansion Headers

Signal Name	FPGA Pin No.	Description	I/O Standard
GPIO[0]	PIN_W15	GPIO Connection 0[0]	3.3V
GPIO[1]	PIN_AK2	GPIO Connection 0[1]	3.3V
GPIO[2]	PIN_Y16	GPIO Connection 0[2]	3.3V
GPIO[3]	PIN_AK3	GPIO Connection 0[3]	3.3V
GPIO[4]	PIN_AJ1	GPIO Connection 0[4]	3.3V
GPIO[5]	PIN_AJ2	GPIO Connection 0[5]	3.3V
GPIO[6]	PIN_AH2	GPIO Connection 0[6]	3.3V
GPIO[7]	PIN_AH3	GPIO Connection 0[7]	3.3V
GPIO[8]	PIN_AH4	GPIO Connection 0[8]	3.3V
GPIO[9]	PIN_AH5	GPIO Connection 0[9]	3.3V
GPIO[10]	PIN_AG1	GPIO Connection 0[10]	3.3V
GPIO[11]	PIN_AG2	GPIO Connection 0[11]	3.3V
GPIO[12]	PIN_AG3	GPIO Connection 0[12]	3.3V
GPIO[13]	PIN_AG5	GPIO Connection 0[13]	3.3V
GPIO[14]	PIN_AG6	GPIO Connection 0[14]	3.3V
GPIO[15]	PIN_AG7	GPIO Connection 0[15]	3.3V
GPIO[16]	PIN_AG8	GPIO Connection 0[16]	3.3V
GPIO[17]	PIN_AF4	GPIO Connection 0[17]	3.3V
GPIO[18]	PIN_AF5	GPIO Connection 0[18]	3.3V
GPIO[19]	PIN_AF6	GPIO Connection 0[19]	3.3V
GPIO[20]	PIN_AF8	GPIO Connection 0[20]	3.3V
GPIO[21]	PIN_AF9	GPIO Connection 0[21]	3.3V
GPIO[22]	PIN_AF10	GPIO Connection 0[22]	3.3V
GPIO[23]	PIN_AE7	GPIO Connection 0[23]	3.3V
GPIO[24]	PIN_AE9	GPIO Connection 0[24]	3.3V
GPIO[25]	PIN_AE11	GPIO Connection 0[25]	3.3V
GPIO[26]	PIN_AE12	GPIO Connection 0[26]	3.3V
GPIO[27]	PIN_AD7	GPIO Connection 0[27]	3.3V

GPIO[28]	PIN_AD9	GPIO Connection 0[28]	3.3V
GPIO[29]	PIN_AD10	GPIO Connection 0[29]	3.3V
GPIO[30]	PIN_AD11	GPIO Connection 0[30]	3.3V
GPIO[31]	PIN_AD12	GPIO Connection 0[31]	3.3V
GPIO[32]	PIN_AC9	GPIO Connection 0[32]	3.3V
GPIO[33]	PIN_AC12	GPIO Connection 0[33]	3.3V
GPIO[34]	PIN_AB12	GPIO Connection 0[34]	3.3V
GPIO[35]	PIN_AA12	GPIO Connection 0[35]	3.3V

3.6.4 HSMC Connector

The board contains a High Speed Mezzanine Card (HSMC) interface to provide a mechanism for extending the peripheral-set of an FPGA host board by means of add-on daughter cards, which can address today's high speed signaling requirements as well as low-speed device interface support. The HSMC interface support JTAG, clock outputs and inputs, high-speed serial I/O (transceivers), and single-ended or differential signaling. Signals on the HSMC port is shown in [Figure 3-20](#). [Table 3-12](#) shows the maximum power consumption of the daughter card that connects to HSMC port.

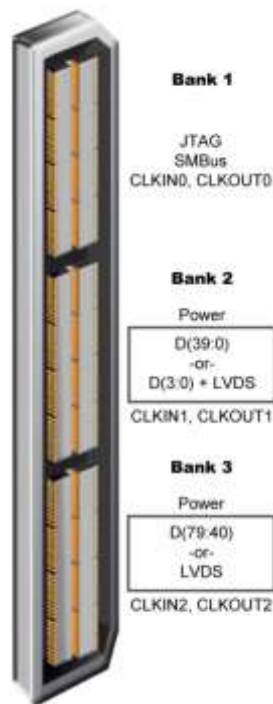

Figure 3-20 HSMC Signal Bank Diagram

Table 3-12 Power Supply of the HSMC

<i>Supplied Voltage</i>	<i>Max. Current Limit</i>
12V	1A
3.3V	1.5A

The voltage level of the I/O pins on the HSMC connector can be adjusted to 3.3V, 2.5V, 1.8V, or 1.5V using JP3 (The default setting is 2.5V). Because the HSMC I/Os are connected to Bank 5B & 8A of the FPGA and the VCCIO voltage of these two banks are controlled by the header JP3, users can use a jumper to select the input voltage of VCCIO5B & VCCIO8A to 3.3V, 2.5V, 1.8V, and 1.5V to control the voltage level of the I/O pins. **Table 3-13** lists the jumper settings of the JP3. **Table 3-14** shows all the pin assignments of the HSMC connector.

Table 3-13 Jumper Settings for different I/O Standards

<i>JP3 Jumper Settings</i>	<i>Supplied Voltage to VCCIO5B & VCCIO8A</i>	<i>I/O Voltage of HSMC Connector (JP2)</i>
Short Pins 1 and 2	1.5V	1.5V
Short Pins 3 and 4	1.8V	1.8V
Short Pins 5 and 6	2.5V	2.5V (Default)
Short Pins 7 and 8	3.3V	3.3V

Table 3-14 Pin Assignments for HSMC connector

<i>Signal Name</i>	<i>FPGA Pin No.</i>	<i>Description</i>	<i>I/O Standard</i>
HSMC_CLKIN0	PIN_J14	Dedicated clock input	Depend on JP3
HSMC_CLKIN_N1	PIN_AB27	LVDS RX or CMOS I/O or differential clock input	Depend on JP3
HSMC_CLKIN_N2	PIN_G15	LVDS RX or CMOS I/O or differential clock input	Depend on JP3
HSMC_CLKIN_P1	PIN_AA26	LVDS RX or CMOS I/O or differential clock input	Depend on JP3
HSMC_CLKIN_P2	PIN_H15	LVDS RX or CMOS I/O or differential clock input	Depend on JP3
HSMC_CLKOUT0	PIN_AD29	Dedicated clock output	Depend on JP3
HSMC_CLKOUT_N1	PIN_E6	LVDS TX or CMOS I/O or differential clock input/output	Depend on JP3
HSMC_CLKOUT_N2	PIN_A10	LVDS TX or CMOS I/O or differential clock input/output	Depend on JP3
HSMC_CLKOUT_P1	PIN_E7	LVDS TX or CMOS I/O or differential clock input/output	Depend on JP3
HSMC_CLKOUT_P2	PIN_A11	LVDS TX or CMOS I/O or differential clock input/output	Depend on JP3
HSMC_D[0]	PIN_C10	LVDS TX or CMOS I/O	Depend on JP3
HSMC_D[1]	PIN_H13	LVDS RX or CMOS I/O	Depend on JP3
HSMC_D[2]	PIN_C9	LVDS TX or CMOS I/O	Depend on JP3
HSMC_D[3]	PIN_H12	LVDS RX or CMOS I/O	Depend on JP3
HSMC_SCL	PIN_AA28	Management serial data	Depend on JP3

HSMC_SDA	PIN_AE29	Management serial clock	Depend on JP3
HSMC_RX_D_N[0]	PIN_G11	LVDS RX bit 0n or CMOS I/O	Depend on JP3
HSMC_RX_D_N[1]	PIN_J12	LVDS RX bit 1n or CMOS I/O	Depend on JP3
HSMC_RX_D_N[2]	PIN_F10	LVDS RX bit 2n or CMOS I/O	Depend on JP3
HSMC_RX_D_N[3]	PIN_J9	LVDS RX bit 3n or CMOS I/O	Depend on JP3
HSMC_RX_D_N[4]	PIN_K8	LVDS RX bit 4n or CMOS I/O	Depend on JP3
HSMC_RX_D_N[5]	PIN_H7	LVDS RX bit 5n or CMOS I/O	Depend on JP3
HSMC_RX_D_N[6]	PIN_G8	LVDS RX bit 6n or CMOS I/O	Depend on JP3
HSMC_RX_D_N[7]	PIN_F8	LVDS RX bit 7n or CMOS I/O	Depend on JP3
HSMC_RX_D_N[8]	PIN_E11	LVDS RX bit 8n or CMOS I/O	Depend on JP3
HSMC_RX_D_N[9]	PIN_B5	LVDS RX bit 9n or CMOS I/O	Depend on JP3
HSMC_RX_D_N[10]	PIN_D9	LVDS RX bit 10n or CMOS I/O	Depend on JP3
HSMC_RX_D_N[11]	PIN_D12	LVDS RX bit 11n or CMOS I/O	Depend on JP3
HSMC_RX_D_N[12]	PIN_D10	LVDS RX bit 12n or CMOS I/O	Depend on JP3
HSMC_RX_D_N[13]	PIN_B12	LVDS RX bit 13n or CMOS I/O	Depend on JP3
HSMC_RX_D_N[14]	PIN_E13	LVDS RX bit 14n or CMOS I/O	Depend on JP3
HSMC_RX_D_N[15]	PIN_G13	LVDS RX bit 15n or CMOS I/O	Depend on JP3
HSMC_RX_D_N[16]	PIN_F14	LVDS RX bit 16n or CMOS I/O	Depend on JP3
HSMC_RX_D_P[0]	PIN_G12	LVDS RX bit 0 or CMOS I/O	Depend on JP3
HSMC_RX_D_P[1]	PIN_K12	LVDS RX bit 1 or CMOS I/O	Depend on JP3
HSMC_RX_D_P[2]	PIN_G10	LVDS RX bit 2 or CMOS I/O	Depend on JP3
HSMC_RX_D_P[3]	PIN_J10	LVDS RX bit 3 or CMOS I/O	Depend on JP3
HSMC_RX_D_P[4]	PIN_K7	LVDS RX bit 4 or CMOS I/O	Depend on JP3
HSMC_RX_D_P[5]	PIN_J7	LVDS RX bit 5 or CMOS I/O	Depend on JP3
HSMC_RX_D_P[6]	PIN_H8	LVDS RX bit 6 or CMOS I/O	Depend on JP3
HSMC_RX_D_P[7]	PIN_F9	LVDS RX bit 7 or CMOS I/O	Depend on JP3
HSMC_RX_D_P[8]	PIN_F11	LVDS RX bit 8 or CMOS I/O	Depend on JP3
HSMC_RX_D_P[9]	PIN_B6	LVDS RX bit 9 or CMOS I/O	Depend on JP3
HSMC_RX_D_P[10]	PIN_E9	LVDS RX bit 10 or CMOS I/O	Depend on JP3
HSMC_RX_D_P[11]	PIN_E12	LVDS RX bit 11 or CMOS I/O	Depend on JP3
HSMC_RX_D_P[12]	PIN_D11	LVDS RX bit 12 or CMOS I/O	Depend on JP3
HSMC_RX_D_P[13]	PIN_C13	LVDS RX bit 13 or CMOS I/O	Depend on JP3
HSMC_RX_D_P[14]	PIN_F13	LVDS RX bit 14 or CMOS I/O	Depend on JP3
HSMC_RX_D_P[15]	PIN_H14	LVDS RX bit 15 or CMOS I/O	Depend on JP3
HSMC_RX_D_P[16]	PIN_F15	LVDS RX bit 16 or CMOS I/O	Depend on JP3
HSMC_TX_D_N[0]	PIN_A8	LVDS TX bit 0n or CMOS I/O	Depend on JP3
HSMC_TX_D_N[1]	PIN_D7	LVDS TX bit 1n or CMOS I/O	Depend on JP3
HSMC_TX_D_N[2]	PIN_F6	LVDS TX bit 2n or CMOS I/O	Depend on JP3
HSMC_TX_D_N[3]	PIN_C5	LVDS TX bit 3n or CMOS I/O	Depend on JP3
HSMC_TX_D_N[4]	PIN_C4	LVDS TX bit 4n or CMOS I/O	Depend on JP3
HSMC_TX_D_N[5]	PIN_E2	LVDS TX bit 5n or CMOS I/O	Depend on JP3
HSMC_TX_D_N[6]	PIN_D4	LVDS TX bit 6n or CMOS I/O	Depend on JP3
HSMC_TX_D_N[7]	PIN_B3	LVDS TX bit 7n or CMOS I/O	Depend on JP3
HSMC_TX_D_N[8]	PIN_D1	LVDS TX bit 8n or CMOS I/O	Depend on JP3
HSMC_TX_D_N[9]	PIN_C2	LVDS TX bit 9n or CMOS I/O	Depend on JP3
HSMC_TX_D_N[10]	PIN_B1	LVDS TX bit 10n or CMOS I/O	Depend on JP3
HSMC_TX_D_N[11]	PIN_A3	LVDS TX bit 11n or CMOS I/O	Depend on JP3



HSMC_TX_D_N[12]	PIN_A5	LVDS TX bit 12n or CMOS I/O	Depend on JP3
HSMC_TX_D_N[13]	PIN_B7	LVDS TX bit 13n or CMOS I/O	Depend on JP3
HSMC_TX_D_N[14]	PIN_B8	LVDS TX bit 14n or CMOS I/O	Depend on JP3
HSMC_TX_D_N[15]	PIN_B11	LVDS TX bit 15n or CMOS I/O	Depend on JP3
HSMC_TX_D_N[16]	PIN_A13	LVDS TX bit 16n or CMOS I/O	Depend on JP3
HSMC_TX_D_P[0]	PIN_A9	LVDS TX bit 0 or CMOS I/O	Depend on JP3
HSMC_TX_D_P[1]	PIN_E8	LVDS TX bit 1 or CMOS I/O	Depend on JP3
HSMC_TX_D_P[2]	PIN_G7	LVDS TX bit 2 or CMOS I/O	Depend on JP3
HSMC_TX_D_P[3]	PIN_D6	LVDS TX bit 3 or CMOS I/O	Depend on JP3
HSMC_TX_D_P[4]	PIN_D5	LVDS TX bit 4 or CMOS I/O	Depend on JP3
HSMC_TX_D_P[5]	PIN_E3	LVDS TX bit 5 or CMOS I/O	Depend on JP3
HSMC_TX_D_P[6]	PIN_E4	LVDS TX bit 6 or CMOS I/O	Depend on JP3
HSMC_TX_D_P[7]	PIN_C3	LVDS TX bit 7 or CMOS I/O	Depend on JP3
HSMC_TX_D_P[8]	PIN_E1	LVDS TX bit 8 or CMOS I/O	Depend on JP3
HSMC_TX_D_P[9]	PIN_D2	LVDS TX bit 9 or CMOS I/O	Depend on JP3
HSMC_TX_D_P[10]	PIN_B2	LVDS TX bit 10 or CMOS I/O	Depend on JP3
HSMC_TX_D_P[11]	PIN_A4	LVDS TX bit 11 or CMOS I/O	Depend on JP3
HSMC_TX_D_P[12]	PIN_A6	LVDS TX bit 12 or CMOS I/O	Depend on JP3
HSMC_TX_D_P[13]	PIN_C7	LVDS TX bit 13 or CMOS I/O	Depend on JP3
HSMC_TX_D_P[14]	PIN_C8	LVDS TX bit 14 or CMOS I/O	Depend on JP3
HSMC_TX_D_P[15]	PIN_C12	LVDS TX bit 15 or CMOS I/O	Depend on JP3
HSMC_TX_D_P[16]	PIN_B13	LVDS TX bit 16 or CMOS I/O	Depend on JP3

3.6.5 24-bit Audio CODEC

The DE10-Standard board offers high-quality 24-bit audio via the Wolfson WM8731 audio CODEC (Encoder/Decoder). This chip supports microphone-in, line-in, and line-out ports, with adjustable sample rate from 8 kHz to 96 kHz. The WM8731 is controlled via serial I2C bus, which is connected to HPS or Cyclone V SoC FPGA through an I2C multiplexer. The connection of the audio circuitry to the FPGA is shown in [Figure 3-21](#), and the associated pin assignment to the FPGA is listed in [Table 3-15](#). More information about the WM8731 codec is available in its datasheet, which can be found on the manufacturer’s website, or in the directory “\datasheets\Audio CODEC” of DE10-Standard System CD.

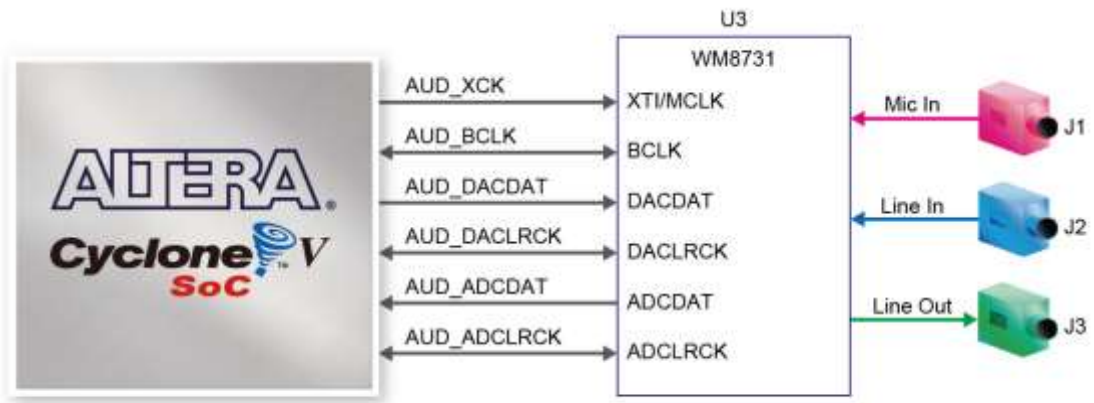

Figure 3-21 Connections between the FPGA and audio CODEC

Table 3-15 Pin Assignment of Audio CODEC

Signal Name	FPGA Pin No.	Description	I/O Standard
AUD_ADCLK	PIN_AH29	Audio CODEC ADC LR Clock	3.3V
AUD_ADCDAT	PIN_AJ29	Audio CODEC ADC Data	3.3V
AUD_DACLK	PIN_AG30	Audio CODEC DAC LR Clock	3.3V
AUD_DACDAT	PIN_AF29	Audio CODEC DAC Data	3.3V
AUD_XCK	PIN_AH30	Audio CODEC Chip Clock	3.3V
AUD_BCLK	PIN_AF30	Audio CODEC Bit-stream Clock	3.3V
I2C_SCLK	PIN_Y24 or PIN_E23	I2C Clock	3.3V
I2C_SDAT	PIN_Y23 or PIN_C24	I2C Data	3.3V

3.6.6 I2C Multiplexer

The DE10-Standard board implements an I2C multiplexer for HPS to access the I2C bus originally owned by FPGA. **Figure 3-22** shows the connection of I2C multiplexer to the FPGA and HPS. HPS can access Audio CODEC and TV Decoder if and only if the HPS_I2C_CONTROL signal is set to high. The pin assignment of the I2C bus is listed in **Table 3-16**.

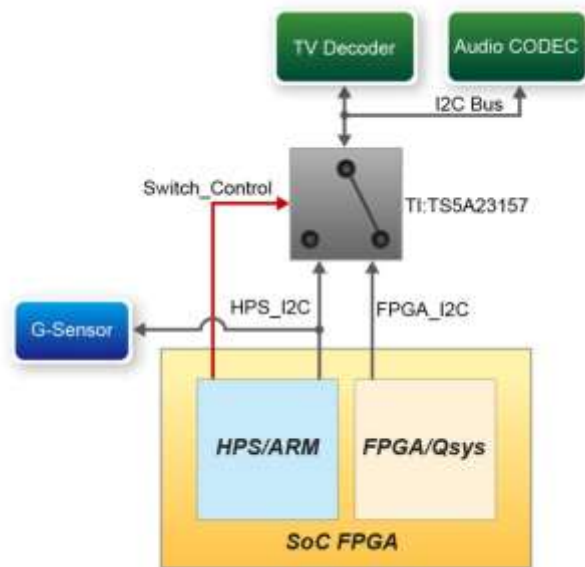

Figure 3-22 Control mechanism for the I2C multiplexer

Table 3-16 Pin Assignment of I2C Bus

Signal Name	FPGA Pin No.	Description	I/O Standard
FPGA_I2C_SCLK	PIN_Y24	FPGA I2C Clock	3.3V
FPGA_I2C_SDAT	PIN_Y23	FPGA I2C Data	3.3V
HPS_I2C1_SCLK	PIN_E23	I2C Clock of the first HPS I2C controller	3.3V
HPS_I2C1_SDAT	PIN_C24	I2C Data of the first HPS I2C controller	3.3V
HPS_I2C2_SCLK	PIN_H23	I2C Clock of the second HPS I2C controller	3.3V
HPS_I2C2_SDAT	PIN_A25	I2C Data of the second HPS I2C controller	3.3V

3.6.7 VGA Output

The DE10-Standard board has a 15-pin D-SUB connector populated for VGA output. The VGA synchronization signals are generated directly from the Cyclone V SoC FPGA, and the Analog Devices ADV7123 triple 10-bit high-speed video DAC (only the higher 8-bits are used) transforms signals from digital to analog to represent three fundamental colors (red, green, and blue). It can support up to SXGA standard (1280*1024) with signals transmitted at 100MHz. **Figure 3-23** shows the signals connected between the FPGA and VGA.

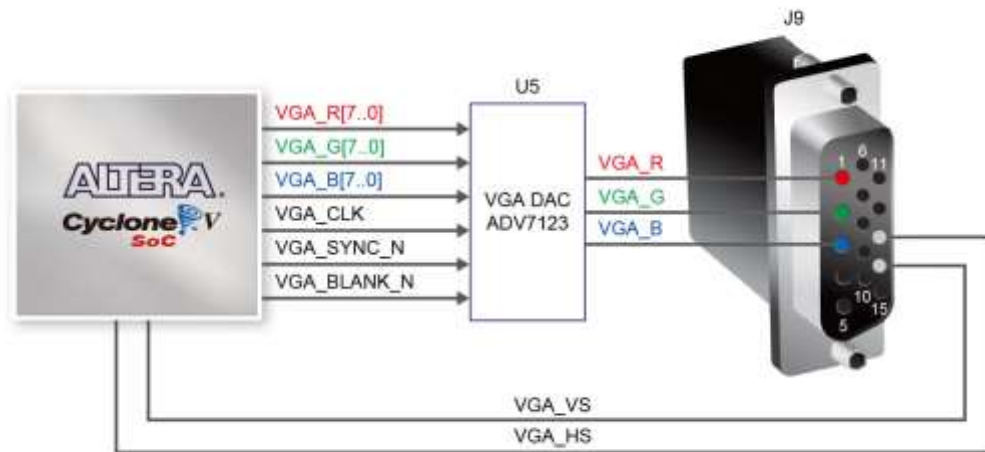

Figure 3-23 Connections between the FPGA and VGA

The timing specification for VGA synchronization and RGB (red, green, blue) data can be easily found on websites nowadays. **Figure 3-24** illustrates the basic timing requirements for each row (horizontal) displayed on a VGA monitor. An active-low pulse of specific duration is applied to the horizontal synchronization (hsync) input of the monitor, which signifies the end of one row of data and the start of the next. The data (RGB) output to the monitor must be off (driven to 0 V) for a time period called the back porch (b) after the hsync pulse occurs, which is followed by the display interval (c). During the data display interval, the RGB data drives each pixel in turn across the row being displayed. Finally, there is a time period called the front porch (d) where the RGB signals must again be off before the next hsync pulse can occur. The timing of vertical synchronization (vsync) is similar to the one shown in **Figure 3-24**, except that a vsync pulse signifies the end of one frame and the start of the next, and the data refers to the set of rows in the frame (horizontal timing). **Table 3-17** and **Table 3-18** show different resolutions and durations of time period a, b, c, and d for both horizontal and vertical timing.

More information about the ADV7123 video DAC is available in its datasheet, which can be found on the manufacturer's website, or in the directory \Datasheets\VIDEO DAC of DE10-Standard System CD. The pin assignment between the Cyclone V SoC FPGA and the ADV7123 is listed in **Table 3-19**.

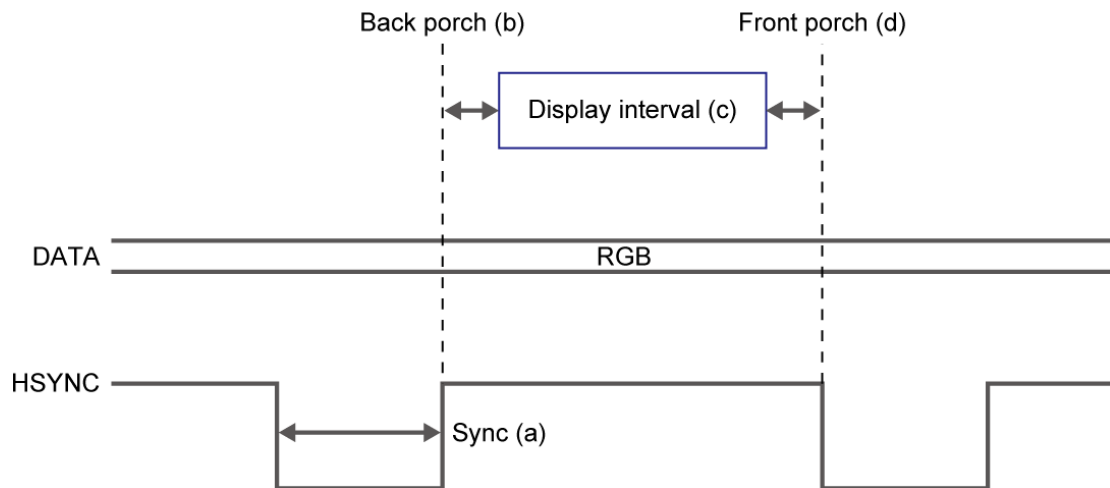

Figure 3-24 VGA horizontal timing specification

Table 3-17 VGA Horizontal Timing Specification

VGA mode		Horizontal Timing Spec				
Configuration	Resolution(HxV)	a(us)	b(us)	c(us)	d(us)	Pixel clock(MHz)
VGA(60Hz)	640x480	3.8	1.9	25.4	0.6	25
VGA(85Hz)	640x480	1.6	2.2	17.8	1.6	36
SVGA(60Hz)	800x600	3.2	2.2	20	1	40
SVGA(75Hz)	800x600	1.6	3.2	16.2	0.3	49
SVGA(85Hz)	800x600	1.1	2.7	14.2	0.6	56
XGA(60Hz)	1024x768	2.1	2.5	15.8	0.4	65
XGA(70Hz)	1024x768	1.8	1.9	13.7	0.3	75
XGA(85Hz)	1024x768	1.0	2.2	10.8	0.5	95
1280x1024(60Hz)	1280x1024	1.0	2.3	11.9	0.4	108

Table 3-18 VGA Vertical Timing Specification

VGA mode		Vertical Timing Spec				
Configuration	Resolution(HxV)	a(lines)	b(lines)	c(lines)	d(lines)	Pixel clock(MHz)
VGA(60Hz)	640x480	2	33	480	10	25
VGA(85Hz)	640x480	3	25	480	1	36
SVGA(60Hz)	800x600	4	23	600	1	40
SVGA(75Hz)	800x600	3	21	600	1	49
SVGA(85Hz)	800x600	3	27	600	1	56
XGA(60Hz)	1024x768	6	29	768	3	65
XGA(70Hz)	1024x768	6	29	768	3	75
XGA(85Hz)	1024x768	3	36	768	1	95
1280x1024(60Hz)	1280x1024	3	38	1024	1	108

Table 3-19 Pin Assignment of VGA

<i>Signal Name</i>	<i>FPGA Pin No.</i>	<i>Description</i>	<i>I/O Standard</i>
VGA_R[0]	PIN_AK29	VGA Red[0]	3.3V
VGA_R[1]	PIN_AK28	VGA Red[1]	3.3V
VGA_R[2]	PIN_AK27	VGA Red[2]	3.3V
VGA_R[3]	PIN_AJ27	VGA Red[3]	3.3V
VGA_R[4]	PIN_AH27	VGA Red[4]	3.3V
VGA_R[5]	PIN_AF26	VGA Red[5]	3.3V
VGA_R[6]	PIN_AG26	VGA Red[6]	3.3V
VGA_R[7]	PIN_AJ26	VGA Red[7]	3.3V
VGA_G[0]	PIN_AK26	VGA Green[0]	3.3V
VGA_G[1]	PIN_AJ25	VGA Green[1]	3.3V
VGA_G[2]	PIN_AH25	VGA Green[2]	3.3V
VGA_G[3]	PIN_AK24	VGA Green[3]	3.3V
VGA_G[4]	PIN_AJ24	VGA Green[4]	3.3V
VGA_G[5]	PIN_AH24	VGA Green[5]	3.3V
VGA_G[6]	PIN_AK23	VGA Green[6]	3.3V
VGA_G[7]	PIN_AH23	VGA Green[7]	3.3V
VGA_B[0]	PIN_AJ21	VGA Blue[0]	3.3V
VGA_B[1]	PIN_AJ20	VGA Blue[1]	3.3V
VGA_B[2]	PIN_AH20	VGA Blue[2]	3.3V
VGA_B[3]	PIN_AJ19	VGA Blue[3]	3.3V
VGA_B[4]	PIN_AH19	VGA Blue[4]	3.3V
VGA_B[5]	PIN_AJ17	VGA Blue[5]	3.3V
VGA_B[6]	PIN_AJ16	VGA Blue[6]	3.3V
VGA_B[7]	PIN_AK16	VGA Blue[7]	3.3V
VGA_CLK	PIN_AK21	VGA Clock	3.3V
VGA_BLANK_N	PIN_AK22	VGA BLANK	3.3V
VGA_HS	PIN_AK19	VGA H_SYNC	3.3V
VGA_VS	PIN_AK18	VGA V_SYNC	3.3V
VGA_SYNC_N	PIN_AJ22	VGA SYNC	3.3V

3.6.8 TV Decoder

The DE10-Standard board is equipped with an Analog Device ADV7180 TV decoder chip. The ADV7180 is an integrated video decoder which automatically detects and converts a standard analog baseband television signals (NTSC, PAL, and SECAM) into 4:2:2 component video data, which is compatible with the 8-bit ITU-R BT.656 interface standard. The ADV7180 is compatible with wide range of video devices, including DVD players, tape-based sources, broadcast sources, and security/surveillance cameras.

The registers in the TV decoder can be accessed and set through the serial I2C bus by the Cyclone V SoC FPGA or HPS. Note that the I2C address W/R of the TV decoder (U4) is 0x40/0x41. The pin

assignment of TV decoder is listed in **Table 3-20**. More information about the ADV7180 is available on the manufacturer's website, or in the directory \DE1_SOC_datasheets\Video Decoder of DE10-Standard System CD.

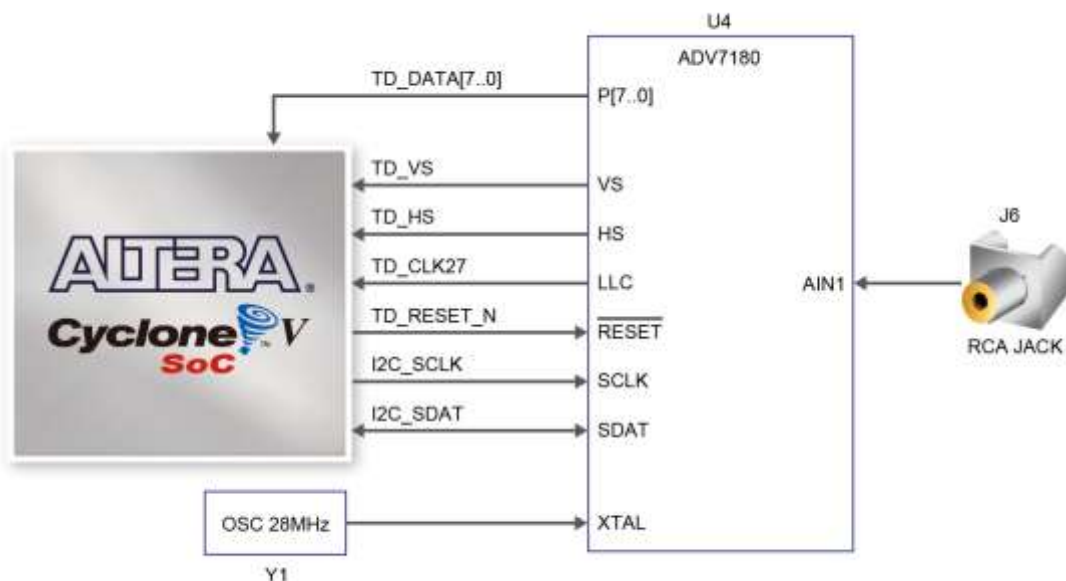

Figure 3-25 Connections between the FPGA and TV Decoder

Table 3-20 Pin Assignment of TV Decoder

Signal Name	FPGA Pin No.	Description	I/O Standard
TD_DATA [0]	PIN_AG27	TV Decoder Data[0]	3.3V
TD_DATA [1]	PIN_AF28	TV Decoder Data[1]	3.3V
TD_DATA [2]	PIN_AE28	TV Decoder Data[2]	3.3V
TD_DATA [3]	PIN_AE27	TV Decoder Data[3]	3.3V
TD_DATA [4]	PIN_AE26	TV Decoder Data[4]	3.3V
TD_DATA [5]	PIN_AD27	TV Decoder Data[5]	3.3V
TD_DATA [6]	PIN_AD26	TV Decoder Data[6]	3.3V
TD_DATA [7]	PIN_AD25	TV Decoder Data[7]	3.3V
TD_HS	PIN_AH28	TV Decoder H_SYNC	3.3V
TD_VS	PIN_AG28	TV Decoder V_SYNC	3.3V
TD_CLK27	PIN_AC18	TV Decoder Clock Input.	3.3V
TD_RESET_N	PIN_AC27	TV Decoder Reset	3.3V
I2C_SCLK	PIN_Y24 or PIN_E23	I2C Clock	3.3V
I2C_SDAT	PIN_Y23 or PIN_C24	I2C Data	3.3V

3.6.9 IR Receiver

The board comes with an infrared remote-control receiver module (model: IRM-V538/TR1), whose datasheet is provided in the directory \Datasheets\ IR Receiver and Emitter of DE10-Standard system CD. The remote control, which is optional and can be ordered from the website, has an encoding chip (uPD6121G) built-in for generating infrared signals. **Figure 3-26** shows the connection of IR receiver to the FPGA. **Table 3-21** shows the pin assignment of IR receiver to the FPGA.

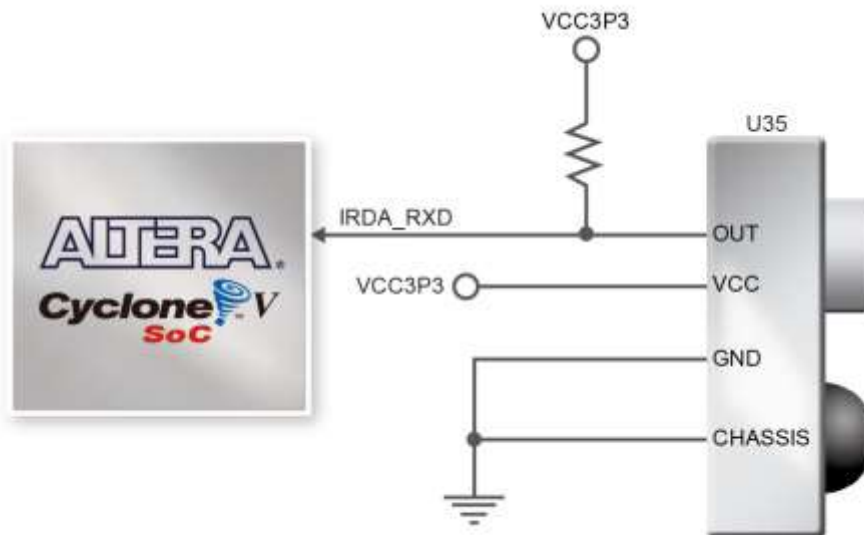

Figure 3-26 Connection between the FPGA and IR Receiver

Table 3-21 Pin Assignment of IR Receiver

Signal Name	FPGA Pin No.	Description	I/O Standard
IRDA_RXD	PIN_W20	IR Receiver	3.3V

3.6.10 IR Emitter LED

The board has an IR emitter LED for IR communication, which is widely used for operating television device wirelessly from a short line-of-sight distance. It can also be used to communicate with other systems by matching this IR emitter LED with another IR receiver on the other side.

Figure 3-27 shows the connection of IR emitter LED to the FPGA. **Table 3-22** shows the pin assignment of IR emitter LED to the FPGA.

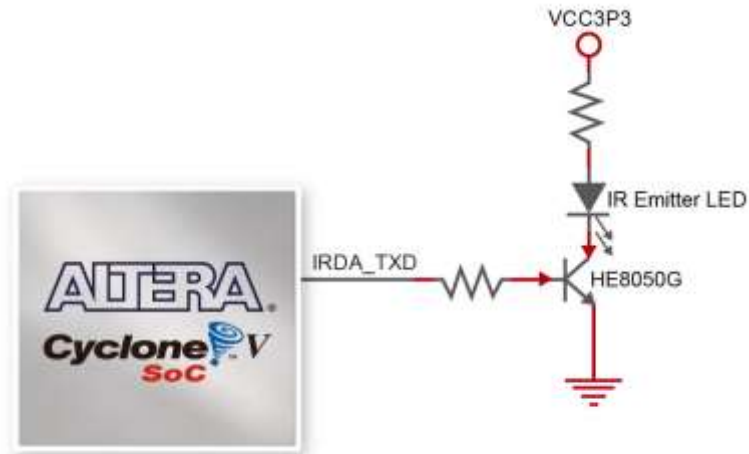

Figure 3-27 Connection between the FPGA and IR emitter LED

Table 3-22 Pin Assignment of IR Emitter LED

Signal Name	FPGA Pin No.	Description	I/O Standard
IRDA_TXD	PIN_W21	IR Emitter	3.3V

3.6.11 SDRAM Memory

The board features 64MB of SDRAM with a single 64MB (32Mx16) SDRAM chip. The chip consists of 16-bit data line, control line, and address line connected to the FPGA. This chip uses the 3.3V LVCMOS signaling standard. Connections between the FPGA and SDRAM are shown in Figure 3-28, and the pin assignment is listed in Table 3-23.



Figure 3-28 Connections between the FPGA and SDRAM

Table 3-23 Pin Assignment of SDRAM

<i>Signal Name</i>	<i>FPGA Pin No.</i>	<i>Description</i>	<i>I/O Standard</i>
DRAM_ADDR[0]	PIN_AK14	SDRAM Address[0]	3.3V
DRAM_ADDR[1]	PIN_AH14	SDRAM Address[1]	3.3V
DRAM_ADDR[2]	PIN_AG15	SDRAM Address[2]	3.3V
DRAM_ADDR[3]	PIN_AE14	SDRAM Address[3]	3.3V
DRAM_ADDR[4]	PIN_AB15	SDRAM Address[4]	3.3V
DRAM_ADDR[5]	PIN_AC14	SDRAM Address[5]	3.3V
DRAM_ADDR[6]	PIN_AD14	SDRAM Address[6]	3.3V
DRAM_ADDR[7]	PIN_AF15	SDRAM Address[7]	3.3V
DRAM_ADDR[8]	PIN_AH15	SDRAM Address[8]	3.3V
DRAM_ADDR[9]	PIN_AG13	SDRAM Address[9]	3.3V
DRAM_ADDR[10]	PIN_AG12	SDRAM Address[10]	3.3V
DRAM_ADDR[11]	PIN_AH13	SDRAM Address[11]	3.3V
DRAM_ADDR[12]	PIN_AJ14	SDRAM Address[12]	3.3V
DRAM_DQ[0]	PIN_AK6	SDRAM Data[0]	3.3V
DRAM_DQ[1]	PIN_AJ7	SDRAM Data[1]	3.3V
DRAM_DQ[2]	PIN_AK7	SDRAM Data[2]	3.3V
DRAM_DQ[3]	PIN_AK8	SDRAM Data[3]	3.3V
DRAM_DQ[4]	PIN_AK9	SDRAM Data[4]	3.3V
DRAM_DQ[5]	PIN_AG10	SDRAM Data[5]	3.3V
DRAM_DQ[6]	PIN_AK11	SDRAM Data[6]	3.3V
DRAM_DQ[7]	PIN_AJ11	SDRAM Data[7]	3.3V
DRAM_DQ[8]	PIN_AH10	SDRAM Data[8]	3.3V
DRAM_DQ[9]	PIN_AJ10	SDRAM Data[9]	3.3V
DRAM_DQ[10]	PIN_AJ9	SDRAM Data[10]	3.3V
DRAM_DQ[11]	PIN_AH9	SDRAM Data[11]	3.3V
DRAM_DQ[12]	PIN_AH8	SDRAM Data[12]	3.3V
DRAM_DQ[13]	PIN_AH7	SDRAM Data[13]	3.3V
DRAM_DQ[14]	PIN_AJ6	SDRAM Data[14]	3.3V
DRAM_DQ[15]	PIN_AJ5	SDRAM Data[15]	3.3V
DRAM_BA[0]	PIN_AF13	SDRAM Bank Address[0]	3.3V
DRAM_BA[1]	PIN_AJ12	SDRAM Bank Address[1]	3.3V
DRAM_LDQM	PIN_AB13	SDRAM byte Data Mask[0]	3.3V
DRAM_UDQM	PIN_AK12	SDRAM byte Data Mask[1]	3.3V
DRAM_RAS_N	PIN_AE13	SDRAM Row Address Strobe	3.3V
DRAM_CAS_N	PIN_AF11	SDRAM Column Address Strobe	3.3V
DRAM_CKE	PIN_AK13	SDRAM Clock Enable	3.3V
DRAM_CLK	PIN_AH12	SDRAM Clock	3.3V
DRAM_WE_N	PIN_AA13	SDRAM Write Enable	3.3V
DRAM_CS_N	PIN_AG11	SDRAM Chip Select	3.3V

3.6.12 PS/2 Serial Port

The DE10-Standard board comes with a standard PS/2 interface and a connector for a PS/2 keyboard or mouse. **Figure 3-29** shows the connection of PS/2 circuit to the FPGA. Users can use the PS/2 keyboard and mouse on the DE10-Standard board simultaneously by a PS/2 Y-Cable, as shown in **Figure 3-30**. Instructions on how to use PS/2 mouse and/or keyboard can be found on various educational websites. The pin assignment associated to this interface is shown in **Table 3-24**.



Note: If users connect only one PS/2 equipment, the PS/2 signals connected to the FPGA I/O should be "PS2_CLK" and "PS2_DAT".

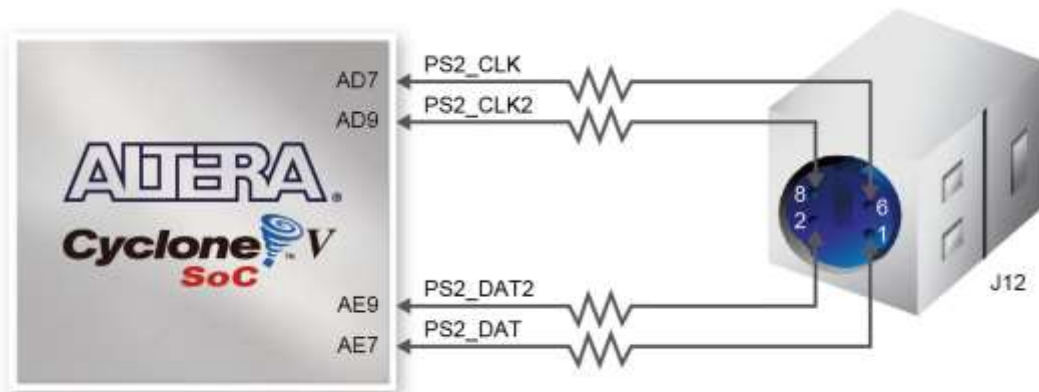

Figure 3-29 Connections between the FPGA and PS/2



Figure 3-30 Y-Cable for using keyboard and mouse simultaneously

Table 3-24 Pin Assignment of PS/2

Signal Name	FPGA Pin No.	Description	I/O Standard
PS2_CLK	PIN_AB25	PS/2 Clock	3.3V
PS2_DAT	PIN_AA25	PS/2 Data	3.3V
PS2_CLK2	PIN_AC25	PS/2 Clock (reserved for second PS/2 device)	3.3V
PS2_DAT2	PIN_AB26	PS/2 Data (reserved for second PS/2 device)	3.3V

3.6.13 A/D Converter and 2x5 Header

The DE10-Standard has an analog-to-digital converter (LTC2308), which features low noise, eight-channel CMOS 12-bit. This ADC offers conversion throughput rate up to 500KSPS. The analog input range for all input channels can be 0 V to 4.096V. The internal conversion clock allows the external serial output data clock (SCLK) to operate at any frequency up to 40MHz. It can be configured to accept eight input signals at inputs ADC_IN0 through ADC_IN7. These eight input signals are connected to a 2x5 header, as shown in [Figure 3-31](#).

More information about the A/D converter chip is available in its datasheet. It can be found on manufacturer's website or in the directory \datasheet of DE10-Standard system CD.

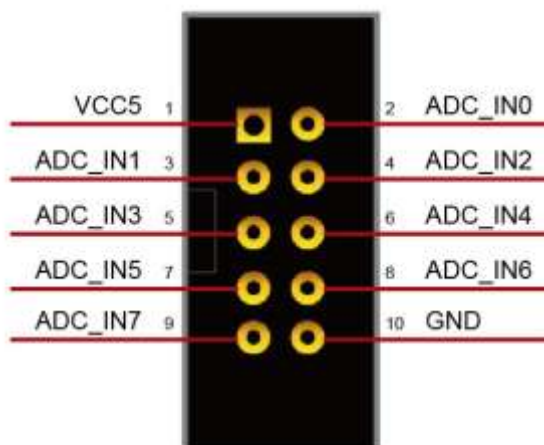

Figure 3-31 Signals of the 2x5 Header

[Figure 3-32](#) shows the connections between the FPGA, 2x5 header, and the A/D converter. [Table 3-25](#) shows the pin assignment of A/D converter.



Figure 3-32 Connections between the FPGA, 2x5 header, and the A/D converter

Table 3-25 Pin Assignment of ADC

Signal Name	FPGA Pin No.	Description	I/O Standard
ADC_CONVST	PIN_Y21	Conversion Start	3.3V
ADC_DOUT	PIN_V23	Digital data input	3.3V
ADC_DIN	PIN_W22	Digital data output	3.3V
ADC_SCLK	PIN_W24	Digital clock input	3.3V

3.7 Peripherals Connected to Hard Processor System (HPS)

This section introduces the interfaces connected to the HPS section of the Cyclone V SoC FPGA. Users can access these interfaces via the HPS processor.

3.7.1 User Push-buttons and LEDs

Similar to the FPGA, the HPS also has its set of switches, buttons, LEDs, and other interfaces connected exclusively. Users can control these interfaces to monitor the status of HPS.

Table 3-26 gives the pin assignment of all the LEDs, switches, and push-buttons.

Table 3-26 Pin Assignment of LEDs, Switches and Push-buttons

Signal Name	HPS GPIO	Register/bit	Function
HPS_KEY	GPIO54	GPIO1[25]	I/O
HPS_LED	GPIO53	GPIO1[24]	I/O

3.7.2 Gigabit Ethernet

The board supports Gigabit Ethernet transfer by an external Micrel KSZ9021RN PHY chip and HPS Ethernet MAC function. The KSZ9021RN chip with integrated 10/100/1000 Mbps Gigabit Ethernet transceiver also supports RGMII MAC interface. **Figure 3-33** shows the connections between the HPS, Gigabit Ethernet PHY, and RJ-45 connector.

The pin assignment associated with Gigabit Ethernet interface is listed in **Table 3-27**. More information about the KSZ9021RN PHY chip and its datasheet, as well as the application notes, is available on the manufacturer’s website.

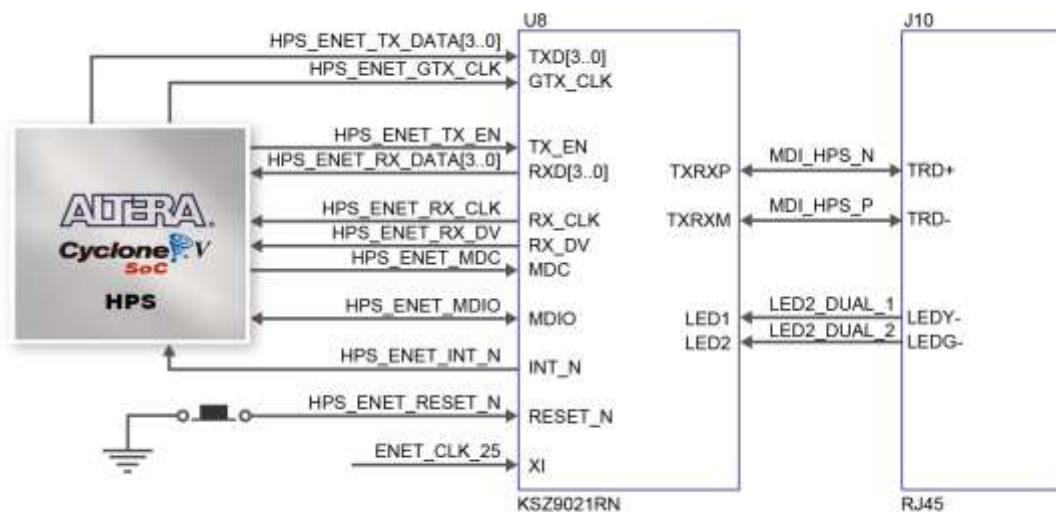

Figure 3-33 Connections between the HPS and Gigabit Ethernet

Table 3-27 Pin Assignment of Gigabit Ethernet PHY

Signal Name	FPGA Pin No.	Description	I/O Standard
HPS_ENET_TX_EN	PIN_A20	GMII and MII transmit enable	3.3V
HPS_ENET_TX_DATA[0]	PIN_F20	MII transmit data[0]	3.3V
HPS_ENET_TX_DATA[1]	PIN_J19	MII transmit data[1]	3.3V
HPS_ENET_TX_DATA[2]	PIN_F21	MII transmit data[2]	3.3V
HPS_ENET_TX_DATA[3]	PIN_F19	MII transmit data[3]	3.3V
HPS_ENET_RX_DV	PIN_K17	GMII and MII receive data valid	3.3V
HPS_ENET_RX_DATA[0]	PIN_A21	GMII and MII receive data[0]	3.3V
HPS_ENET_RX_DATA[1]	PIN_B20	GMII and MII receive data[1]	3.3V
HPS_ENET_RX_DATA[2]	PIN_B18	GMII and MII receive data[2]	3.3V
HPS_ENET_RX_DATA[3]	PIN_D21	GMII and MII receive data[3]	3.3V
HPS_ENET_RX_CLK	PIN_G20	GMII and MII receive clock	3.3V
HPS_ENET_RESET_N	PIN_E18	Hardware Reset Signal	3.3V
HPS_ENET_MDIO	PIN_E21	Management Data	3.3V
HPS_ENET_MDC	PIN_B21	Management Data Clock	3.3V

		Reference	
HPS_ENET_INT_N	PIN_C19	Interrupt Open Drain Output	3.3V
HPS_ENET_GTX_CLK	PIN_H19	GMIIT Transmit Clock	3.3V

There are two LEDs, green LED (LEDG) and yellow LED (LEDY), which represent the status of Ethernet PHY (KSZ9021RNI). The LED control signals are connected to the LEDs on the RJ45 connector. The state and definition of LEDG and LEDY are listed in **Table 3-28**. For instance, the connection from board to Gigabit Ethernet is established once the LEDG lights on.

Table 3-28 State and Definition of LED Mode Pins

LED (State)		LED (Definition)		Link /Activity
LEDG	LEDY	LEDG	LEDY	
H	H	OFF	OFF	Link off
L	H	ON	OFF	1000 Link / No Activity
Toggle	H	Blinking	OFF	1000 Link / Activity (RX, TX)
H	L	OFF	ON	100 Link / No Activity
H	Toggle	OFF	Blinking	100 Link / Activity (RX, TX)
L	L	ON	ON	10 Link/ No Activity
Toggle	Toggle	Blinking	Blinking	10 Link / Activity (RX, TX)

3.7.3 UART to USB

The board has one UART interface connected for communication with the HPS. This interface doesn't support HW flow control signals. The physical interface is implemented by UART-USB onboard bridge from a FT232R chip to the host with an USB Mini-B connector. More information about the chip is available on the manufacturer's website, or in the directory \Datasheets\UART TO USB of DE10-Standard system CD. **Figure 3-34** shows the connections between the HPS, FT232R chip, and the USB Mini-B connector. **Table 3-29** lists the pin assignment of UART interface connected to the HPS.

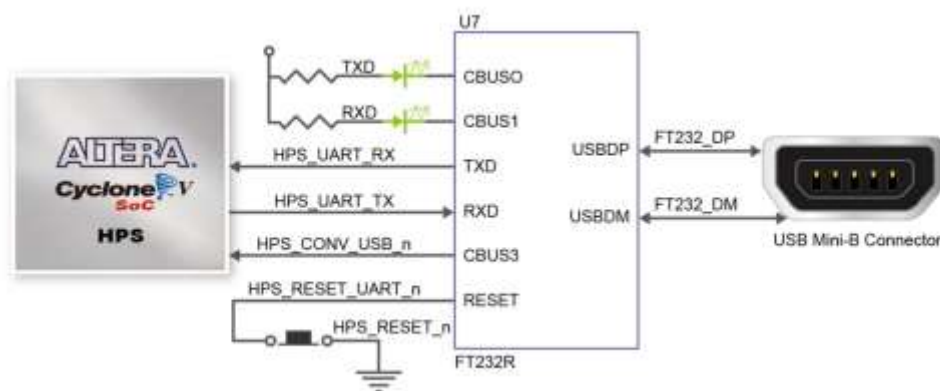

Figure 3-34 Connections between the HPS and FT232R Chip

Table 3-29 Pin Assignment of UART Interface

Signal Name	FPGA Pin No.	Description	I/O Standard
HPS_UART_RX	PIN_B25	HPS UART Receiver	3.3V
HPS_UART_TX	PIN_C25	HPS UART Transmitter	3.3V
HPS_CONV_USB_N	PIN_B15	Reserve	3.3V

3.7.4 DDR3 Memory

The board supports 1GB of DDR3 SDRAM comprising of two x16 bit DDR3 devices on HPS side. The signals are connected to the dedicated Hard Memory Controller for HPS I/O banks and the target speed is 400MHz. **Figure 3-35** shows the connections between the DDR3 and Cyclone V SoC FPGA. **Table 3-30** lists the pin assignment of DDR3 and its description with I/O standard.

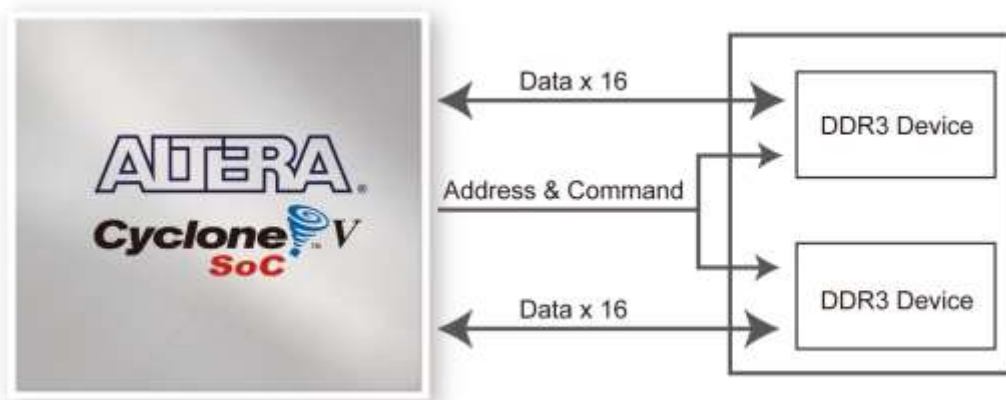

Figure 3-35 Connections between FPGA and DDR3

Table 3-30 Pin Assignment of DDR3 Memory

Signal Name	FPGA Pin No.	Description	I/O Standard
HPS_DDR3_A[0]	PIN_F26	HPS DDR3 Address[0]	SSTL-15 Class I
HPS_DDR3_A[1]	PIN_G30	HPS DDR3 Address[1]	SSTL-15 Class I
HPS_DDR3_A[2]	PIN_F28	HPS DDR3 Address[2]	SSTL-15 Class I
HPS_DDR3_A[3]	PIN_F30	HPS DDR3 Address[3]	SSTL-15 Class I
HPS_DDR3_A[4]	PIN_J25	HPS DDR3 Address[4]	SSTL-15 Class I
HPS_DDR3_A[5]	PIN_J27	HPS DDR3 Address[5]	SSTL-15 Class I
HPS_DDR3_A[6]	PIN_F29	HPS DDR3 Address[6]	SSTL-15 Class I
HPS_DDR3_A[7]	PIN_E28	HPS DDR3 Address[7]	SSTL-15 Class I
HPS_DDR3_A[8]	PIN_H27	HPS DDR3 Address[8]	SSTL-15 Class I
HPS_DDR3_A[9]	PIN_G26	HPS DDR3 Address[9]	SSTL-15 Class I
HPS_DDR3_A[10]	PIN_D29	HPS DDR3 Address[10]	SSTL-15 Class I
HPS_DDR3_A[11]	PIN_C30	HPS DDR3 Address[11]	SSTL-15 Class I
HPS_DDR3_A[12]	PIN_B30	HPS DDR3 Address[12]	SSTL-15 Class I
HPS_DDR3_A[13]	PIN_C29	HPS DDR3 Address[13]	SSTL-15 Class I
HPS_DDR3_A[14]	PIN_H25	HPS DDR3 Address[14]	SSTL-15 Class I
HPS_DDR3_BA[0]	PIN_E29	HPS DDR3 Bank Address[0]	SSTL-15 Class I

HPS_DDR3_BA[1]	PIN_J24	HPS DDR3 Bank Address[1]	SSTL-15 Class I
HPS_DDR3_BA[2]	PIN_J23	HPS DDR3 Bank Address[2]	SSTL-15 Class I
HPS_DDR3_CAS_n	PIN_E27	DDR3 Column Address Strobe	SSTL-15 Class I
HPS_DDR3_CKE	PIN_L29	HPS DDR3 Clock Enable	SSTL-15 Class I
HPS_DDR3_CK_n	PIN_L23	HPS DDR3 Clock	Differential 1.5-V SSTL Class I
HPS_DDR3_CK_p	PIN_M23	HPS DDR3 Clock p	Differential 1.5-V SSTL Class I
HPS_DDR3_CS_n	PIN_H24	HPS DDR3 Chip Select	SSTL-15 Class I
HPS_DDR3_DM[0]	PIN_K28	HPS DDR3 Data Mask[0]	SSTL-15 Class I
HPS_DDR3_DM[1]	PIN_M28	HPS DDR3 Data Mask[1]	SSTL-15 Class I
HPS_DDR3_DM[2]	PIN_R28	HPS DDR3 Data Mask[2]	SSTL-15 Class I
HPS_DDR3_DM[3]	PIN_W30	HPS DDR3 Data Mask[3]	SSTL-15 Class I
HPS_DDR3_DQ[0]	PIN_K23	HPS DDR3 Data[0]	SSTL-15 Class I
HPS_DDR3_DQ[1]	PIN_K22	HPS DDR3 Data[1]	SSTL-15 Class I
HPS_DDR3_DQ[2]	PIN_H30	HPS DDR3 Data[2]	SSTL-15 Class I
HPS_DDR3_DQ[3]	PIN_G28	HPS DDR3 Data[3]	SSTL-15 Class I
HPS_DDR3_DQ[4]	PIN_L25	HPS DDR3 Data[4]	SSTL-15 Class I
HPS_DDR3_DQ[5]	PIN_L24	HPS DDR3 Data[5]	SSTL-15 Class I
HPS_DDR3_DQ[6]	PIN_J30	HPS DDR3 Data[6]	SSTL-15 Class I
HPS_DDR3_DQ[7]	PIN_J29	HPS DDR3 Data[7]	SSTL-15 Class I
HPS_DDR3_DQ[8]	PIN_K26	HPS DDR3 Data[8]	SSTL-15 Class I
HPS_DDR3_DQ[9]	PIN_L26	HPS DDR3 Data[9]	SSTL-15 Class I
HPS_DDR3_DQ[10]	PIN_K29	HPS DDR3 Data[10]	SSTL-15 Class I
HPS_DDR3_DQ[11]	PIN_K27	HPS DDR3 Data[11]	SSTL-15 Class I
HPS_DDR3_DQ[12]	PIN_M26	HPS DDR3 Data[12]	SSTL-15 Class I
HPS_DDR3_DQ[13]	PIN_M27	HPS DDR3 Data[13]	SSTL-15 Class I
HPS_DDR3_DQ[14]	PIN_L28	HPS DDR3 Data[14]	SSTL-15 Class I
HPS_DDR3_DQ[15]	PIN_M30	HPS DDR3 Data[15]	SSTL-15 Class I
HPS_DDR3_DQ[16]	PIN_U26	HPS DDR3 Data[16]	SSTL-15 Class I
HPS_DDR3_DQ[17]	PIN_T26	HPS DDR3 Data[17]	SSTL-15 Class I
HPS_DDR3_DQ[18]	PIN_N29	HPS DDR3 Data[18]	SSTL-15 Class I
HPS_DDR3_DQ[19]	PIN_N28	HPS DDR3 Data[19]	SSTL-15 Class I
HPS_DDR3_DQ[20]	PIN_P26	HPS DDR3 Data[20]	SSTL-15 Class I
HPS_DDR3_DQ[21]	PIN_P27	HPS DDR3 Data[21]	SSTL-15 Class I
HPS_DDR3_DQ[22]	PIN_N27	HPS DDR3 Data[22]	SSTL-15 Class I
HPS_DDR3_DQ[23]	PIN_R29	HPS DDR3 Data[23]	SSTL-15 Class I
HPS_DDR3_DQ[24]	PIN_P24	HPS DDR3 Data[24]	SSTL-15 Class I
HPS_DDR3_DQ[25]	PIN_P25	HPS DDR3 Data[25]	SSTL-15 Class I
HPS_DDR3_DQ[26]	PIN_T29	HPS DDR3 Data[26]	SSTL-15 Class I
HPS_DDR3_DQ[27]	PIN_T28	HPS DDR3 Data[27]	SSTL-15 Class I
HPS_DDR3_DQ[28]	PIN_R27	HPS DDR3 Data[28]	SSTL-15 Class I
HPS_DDR3_DQ[29]	PIN_R26	HPS DDR3 Data[29]	SSTL-15 Class I
HPS_DDR3_DQ[30]	PIN_V30	HPS DDR3 Data[30]	SSTL-15 Class I
HPS_DDR3_DQ[31]	PIN_W29	HPS DDR3 Data[31]	SSTL-15 Class I
HPS_DDR3_DQS_n[0]	PIN_M19	HPS DDR3 Data Strobe n[0]	Differential 1.5-V SSTL Class I

HPS_DDR3_DQS_n[1]	PIN_N24	HPS DDR3 Data Strobe n[1]	Differential 1.5-V SSTL Class I
HPS_DDR3_DQS_n[2]	PIN_R18	HPS DDR3 Data Strobe n[2]	Differential 1.5-V SSTL Class I
HPS_DDR3_DQS_n[3]	PIN_R21	HPS DDR3 Data Strobe n[3]	Differential 1.5-V SSTL Class I
HPS_DDR3_DQS_p[0]	PIN_N18	HPS DDR3 Data Strobe p[0]	Differential 1.5-V SSTL Class I
HPS_DDR3_DQS_p[1]	PIN_N25	HPS DDR3 Data Strobe p[1]	Differential 1.5-V SSTL Class I
HPS_DDR3_DQS_p[2]	PIN_R19	HPS DDR3 Data Strobe p[2]	Differential 1.5-V SSTL Class I
HPS_DDR3_DQS_p[3]	PIN_R22	HPS DDR3 Data Strobe p[3]	Differential 1.5-V SSTL Class I
HPS_DDR3_ODT	PIN_H28	HPS DDR3 On-die Termination	SSTL-15 Class I
HPS_DDR3_RAS_n	PIN_D30	DDR3 Row Address Strobe	SSTL-15 Class I
HPS_DDR3_RESET_n	PIN_P30	HPS DDR3 Reset	SSTL-15 Class I
HPS_DDR3_WE_n	PIN_C28	HPS DDR3 Write Enable	SSTL-15 Class I
HPS_DDR3_RZQ	PIN_D27	External reference ball for output drive calibration	1.5 V

3.7.5 Micro SD Card Socket

The board supports Micro SD card interface with x4 data lines. It serves not only an external storage for the HPS, but also an alternative boot option for DE10-Standard board. **Figure 3-36** shows signals connected between the HPS and Micro SD card socket.

Table 3-31 lists the pin assignment of Micro SD card socket to the HPS.

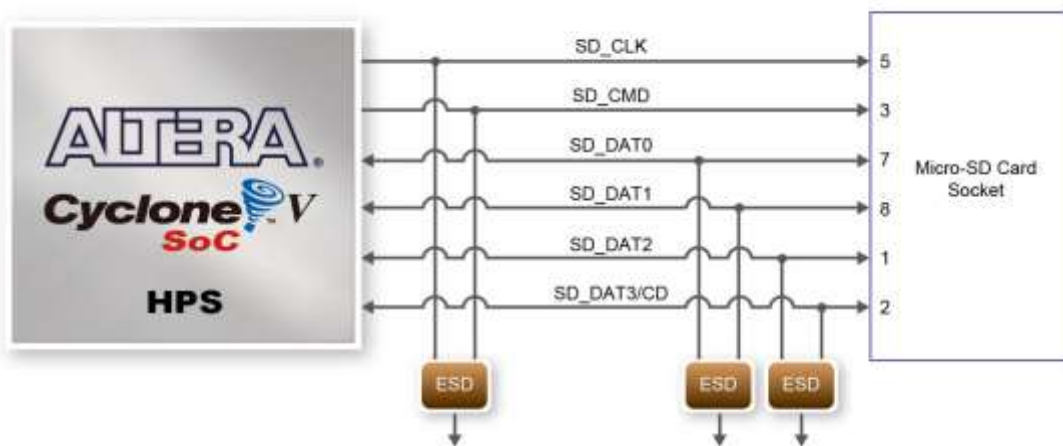

Figure 3-36 Connections between the FPGA and SD card socket

Table 3-31 Pin Assignment of Micro SD Card Socket

Signal Name	FPGA Pin No.	Description	I/O Standard
HPS_SD_CLK	PIN_A16	HPS SD Clock	3.3V
HPS_SD_CMD	PIN_F18	HPS SD Command Line	3.3V
HPS_SD_DATA[0]	PIN_G18	HPS SD Data[0]	3.3V
HPS_SD_DATA[1]	PIN_C17	HPS SD Data[1]	3.3V
HPS_SD_DATA[2]	PIN_D17	HPS SD Data[2]	3.3V
HPS_SD_DATA[3]	PIN_B16	HPS SD Data[3]	3.3V

3.7.6 2-port USB Host

The board has two USB 2.0 type-A ports with a SMSC USB3300 controller and a 2-port hub controller. The SMSC USB3300 device in 32-pin QFN package interfaces with the SMSC USB2512B hub controller. This device supports UTMI+ Low Pin Interface (ULPI), which communicates with the USB 2.0 controller in HPS. The PHY operates in Host mode by connecting the ID pin of USB3300 to ground. When operating in Host mode, the device is powered by the two USB type-A ports. Figure 3-37 shows the connections of USB PTG PHY to the HPS. Table 3-32 lists the pin assignment of USBOTG PHY to the HPS.

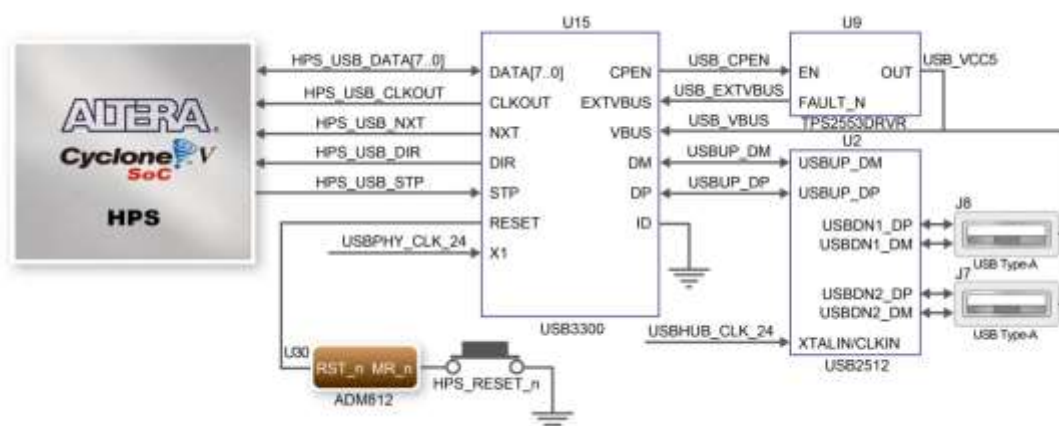

Figure 3-37 Connections between the HPS and USB OTG PHY

Table 3-32 Pin Assignment of USB OTG PHY

Signal Name	FPGA Pin No.	Description	I/O Standard
HPS_USB_CLKOUT	PIN_N16	60MHz Reference Clock Output	3.3V
HPS_USB_DATA[0]	PIN_E16	HPS USB_DATA[0]	3.3V
HPS_USB_DATA[1]	PIN_G16	HPS USB_DATA[1]	3.3V
HPS_USB_DATA[2]	PIN_D16	HPS USB_DATA[2]	3.3V
HPS_USB_DATA[3]	PIN_D14	HPS USB_DATA[3]	3.3V
HPS_USB_DATA[4]	PIN_A15	HPS USB_DATA[4]	3.3V
HPS_USB_DATA[5]	PIN_C14	HPS USB_DATA[5]	3.3V

HPS_USB_DATA[6]	PIN_D15	HPS USB_DATA[6]	3.3V
HPS_USB_DATA[7]	PIN_M17	HPS USB_DATA[7]	3.3V
HPS_USB_DIR	PIN_E14	Direction of the Data Bus	3.3V
HPS_USB_NXT	PIN_A14	Throttle the Data	3.3V
HPS_USB_RESET	PIN_G17	HPS USB PHY Reset	3.3V
HPS_USB_STP	PIN_C15	Stop Data Stream on the Bus	3.3V

3.7.7 Accelerometer (G-sensor)

The board comes with a digital accelerometer sensor module (ADXL345), commonly known as G-sensor. This G-sensor is a small, thin, ultralow power assumption 3-axis accelerometer with high-resolution measurement. Digitalized output is formatted as 16-bit in two's complement and can be accessed through I2C interface. The I2C address of G-sensor is 0xA6/0xA7. More information about this chip can be found in its datasheet, which is available on manufacturer's website or in the directory \Datasheet folder of DE10-Standard system CD. **Figure 3-38** shows the connections between the HPS and G-sensor. **Table 3-33** lists the pin assignment of G-sensor to the HPS.

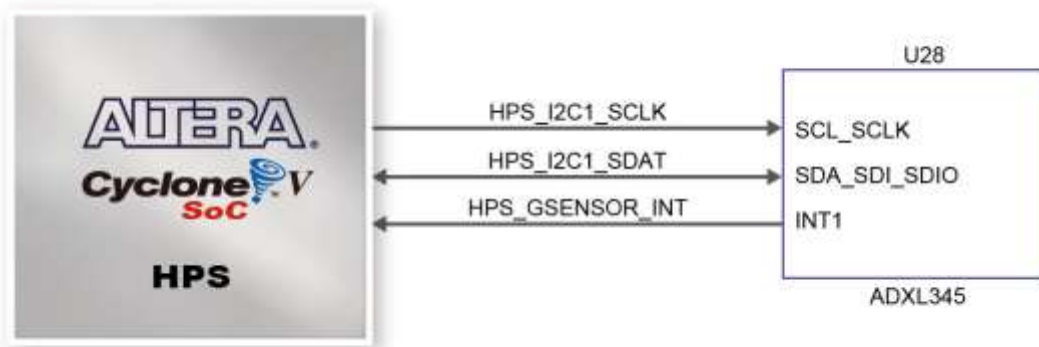

Figure 3-38 Connections between Cyclone V SoC FPGA and G-Sensor

Table 3-33 Pin Assignment of G-sensor

Signal Name	FPGA Pin No.	Description	I/O Standard
HPS_GSENSOR_INT	PIN_B22	HPS GSENSOR Interrupt Output	3.3V
HPS_I2C1_SCLK	PIN_E23	HPS I2C Clock (share bus with LTC)	3.3V
HPS_I2C1_SDAT	PIN_C24	HPS I2C Data (share bus)	3.3V

3.7.8 LTC Connector

The board has a 14-pin header, which is originally used to communicate with various daughter cards from Linear Technology. It is connected to the SPI Master and I2C ports of HPS. The communication with these two protocols is bi-directional. The 14-pin header can also be used for

GPIO, SPI, or I2C based communication with the HPS. Connections between the HPS and LTC connector are shown in **Figure 3-39**, and the pin assignment of LTC connector is listed in **Table 3-34**.

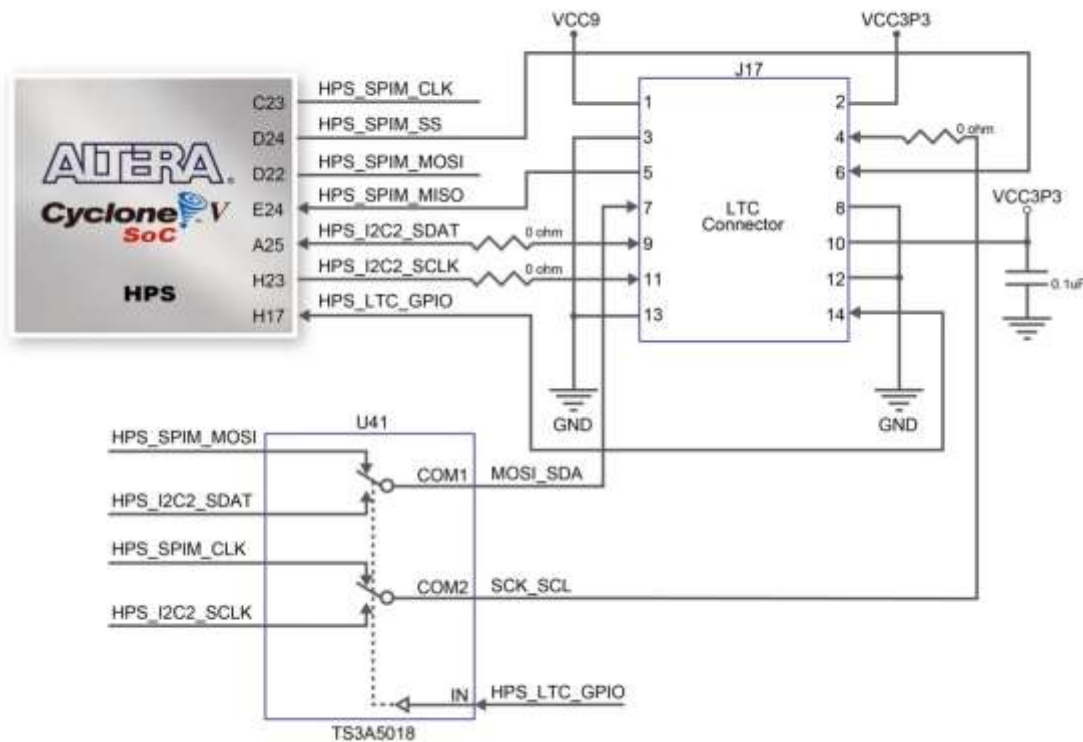

Figure 3-39 Connections between the HPS and LTC connector

Table 3-34 Pin Assignment of LTC Connector

Signal Name	FPGA Pin No.	Description	I/O Standard
HPS_LTC_GPIO	PIN_H17	HPS LTC GPIO	3.3V
HPS_I2C2_SCLK	PIN_H23	HPS I2C2 Clock (share bus with G-Sensor)	3.3V
HPS_I2C2_SDAT	PIN_A25	HPS I2C2 Data (share bus with G-Sensor)	3.3V
HPS_SPIM_CLK	PIN_C23	SPI Clock	3.3V
HPS_SPIM_MISO	PIN_E24	SPI Master Input/Slave Output	3.3V
HPS_SPIM_MOSI	PIN_D22	SPI Master Output /Slave Input	3.3V
HPS_SPIM_SS	PIN_D24	SPI Slave Select	3.3V

3.7.9 128x64 Dots LCD

The board equips an LCD Module with 128x64 dots for display capabilities. The LCD module uses serial peripheral interface to connect with the HPS. To use the LCD module, please refer to the datasheet folder in System CD. **Figure 3-40** shows the connections between the HPS and LCD module. The default setting for LCD backlight power is ON by shorting the pins of header JP4.

Table 3-35 lists the pin assignments between LCD module and Cyclone V SoC FPGA.

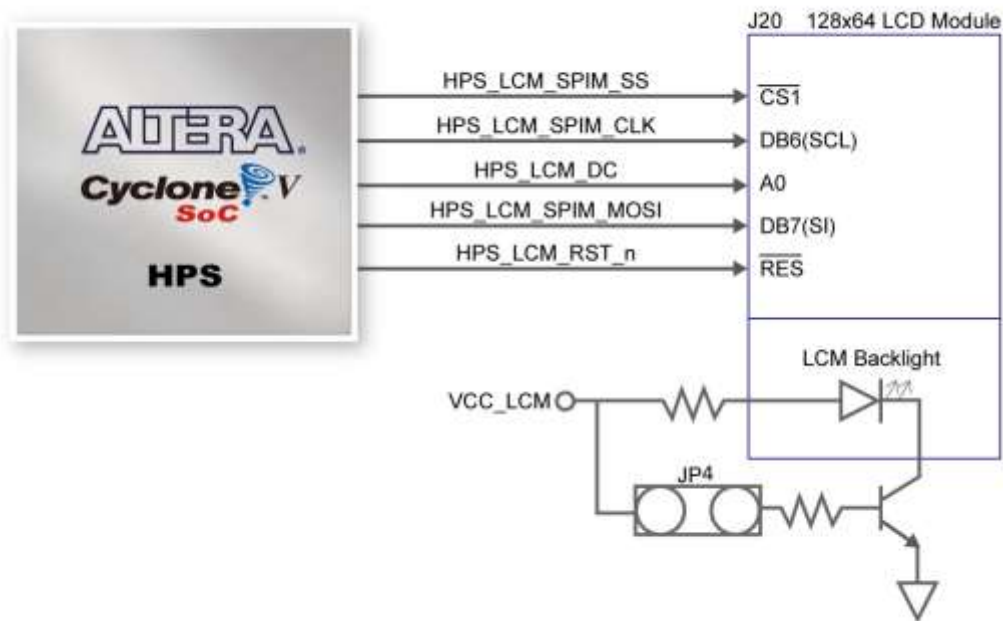

Figure 3-40 Connections between Cyclone V SoC FPGA and LCD Module

Table 3-35 LCD Module Pin Assignments

Signal Name	FPGA Pin No.	Description	I/O Standard
HPS_LCM_D_C	PIN_C18	HPS LCM Data bit is Data/Command	3.3V
HPS_LCM_RST_N	PIN_E17	HPS LCM Reset	3.3V
HPS_LCM_SPIM_CLK	PIN_A23	SPI Clock	3.3V
HPS_LCM_SPIM_MOSI	PIN_C22	SPI Master Output /Slave Input	3.3V
HPS_LCM_SPIM_SS	PIN_H20	SPI Slave Select	3.3V

Chapter 4

DE10-Standard System Builder

The developers can start their Quartus project based on the golden_top quartus project included in the DE10-Standard System CD. Nevertheless, if developers plan to use Terasic daughters or require only a few interfaces in DE10-Standard, the System Builder can assist developers to establish Quartus project within minutes.

This chapter describes how users can create a custom design project with the tool named DE10-Standard System Builder.

4.1 Introduction

The DE10-Standard System Builder is a Windows-based utility. It is designed to help users create a Quartus II project for DE10-Standard within minutes. The generated Quartus II project files include:

- Quartus II project file (.qpf)
- Quartus II setting file (.qsf)
- Top-level design file (.v or .vhd)
- Synopsis design constraints file (.sdc)
- Pin assignment document (.htm)

The above files generated by the DE10-Standard System Builder can also prevent occurrence of situations that are prone to compilation error when users manually edit the top-level design file or place pin assignment. The common mistakes users may encounter are:

- Board is damaged due to incorrect bank voltage setting or pin assignment.
- Board is malfunctioned because of wrong device chosen, declaration of pin location or direction is incorrect or forgotten.
- Performance degradation due to improper pin assignment.



4.2 Design Flow

This section provides an introduction to the design flow of building a Quartus II project for DE10-Standard under the DE10-Standard System Builder. The design flow is illustrated in **Figure 4-1**.

The DE10-Standard System Builder will generate two major files, a top-level design file (.v or .vhd) and a Quartus II setting file (.qsf) after users launch the DE10-Standard System Builder and create a new project according to their design requirements.

The top-level design file contains a top-level Verilog or VHDL HDL wrapper for users to add their own design/logic. The Quartus II setting file contains information such as FPGA device type, top-level pin assignment, and the I/O standard for each user-defined I/O pin.

Finally, the Quartus II programmer is used to download .sof file to the development board via JTAG interface.

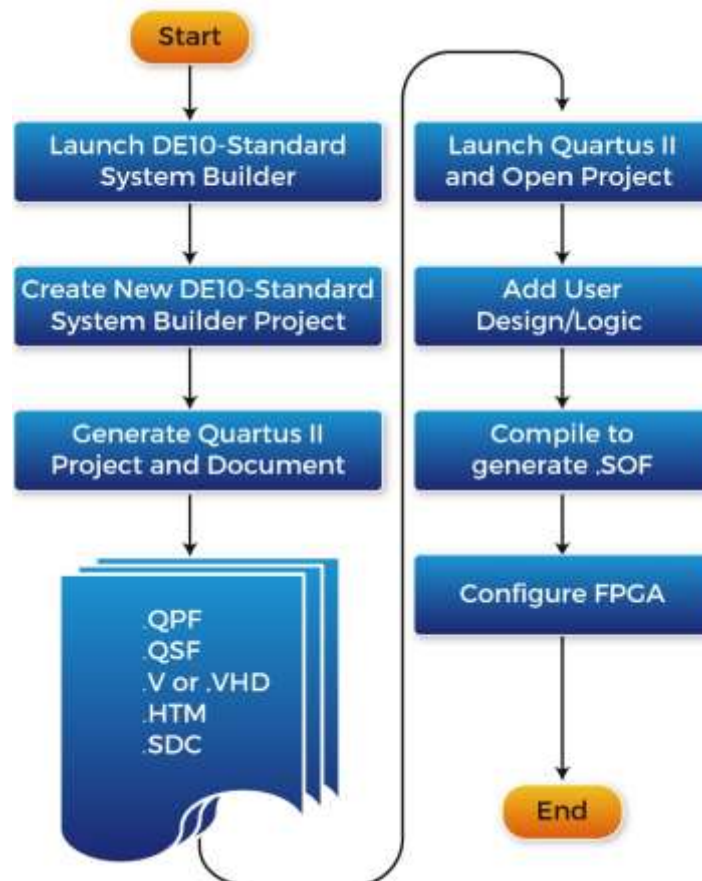

Figure 4-1 Design flow of building a project from the beginning to the end

4.3 Using DE10-Standard System Builder

This section provides the complete procedure on how to use the DE10-Standard System Builder.

■ Install and Launch the DE10-Standard System Builder

The DE10-Standard System Builder is located in the directory: “Tools\SystemBuilder” of the DE10-Standard System CD. Users can copy the entire folder to a host computer without installing the utility. A window will pop up, as shown in **Figure 4-2**, after executing the DE10-Standard SystemBuilder.exe on the host computer.

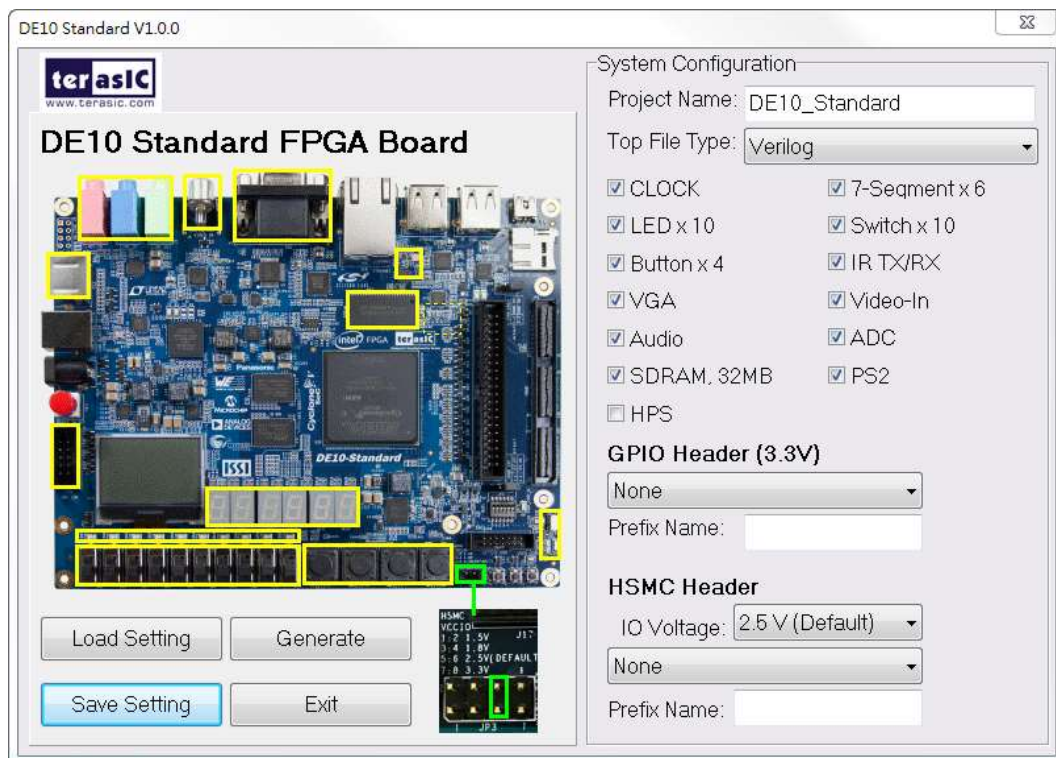

Figure 4-2 The GUI of DE10-Standard System Builder

■ Enter Project Name

Enter the project name in the circled area, as shown in **Figure 4-3**.

The project name typed in will be assigned automatically as the name of your top-level design entity.

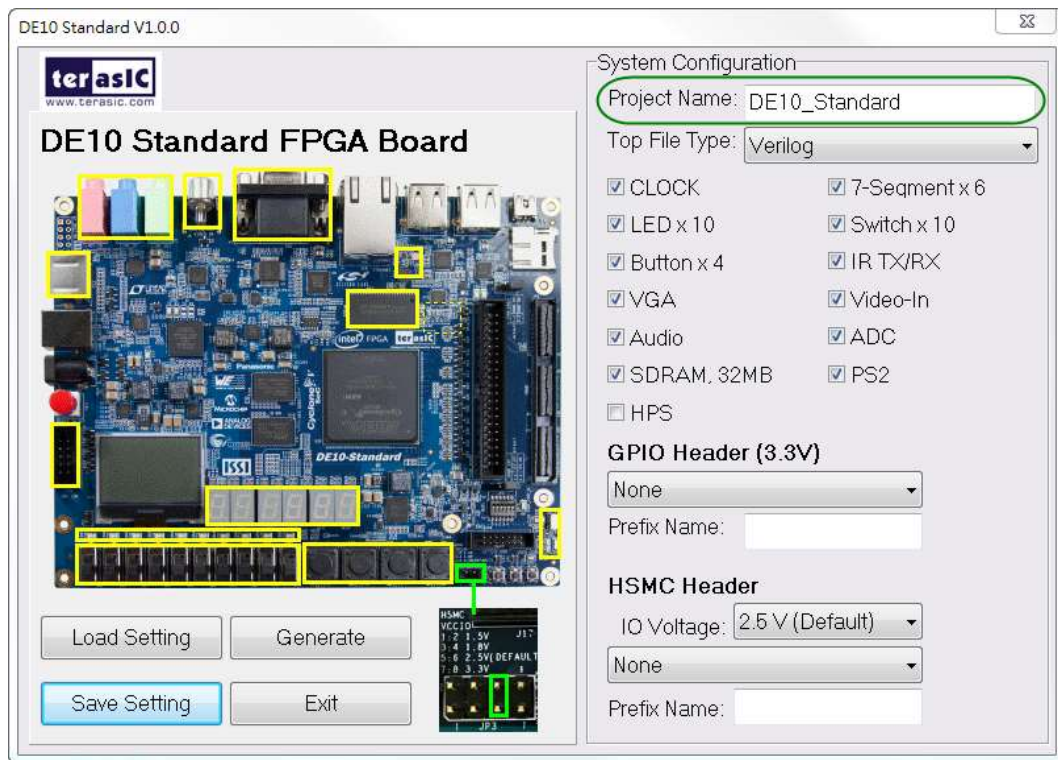

Figure 4-3 Enter the project name

■ Top File Type

Select the desired HDL type, as shown in **Figure 4-4**. If **Verilog** is selected, a .v Verilog HDL top file will be generated. If **VHDL** HDL is selected, a .vhd VHDL top file will be generated.

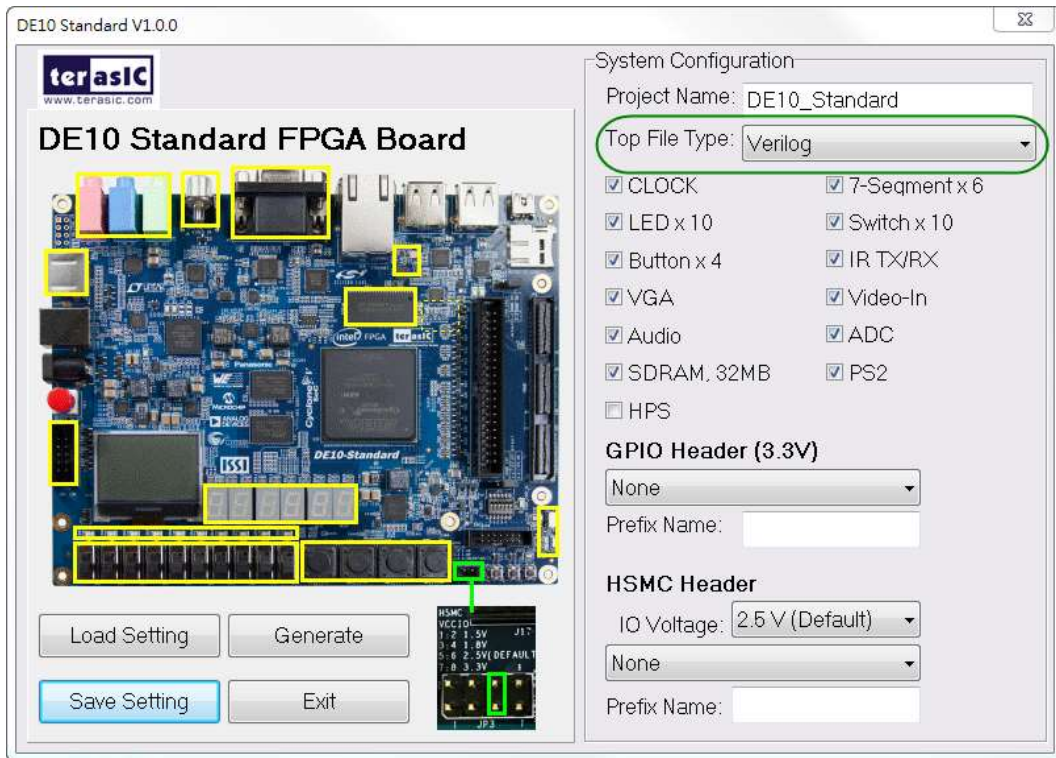

Figure 4-4 Select Top File Type

■ System Configuration

Users are given the flexibility in the System Configuration to include their choice of components in the project, as shown in **Figure 4-5**. Each component onboard is listed and users can enable or disable one or more components at will. If a component is enabled, the DE10-Standard System Builder will automatically generate its associated pin assignment, including the pin name, pin location, pin direction, and I/O standard.

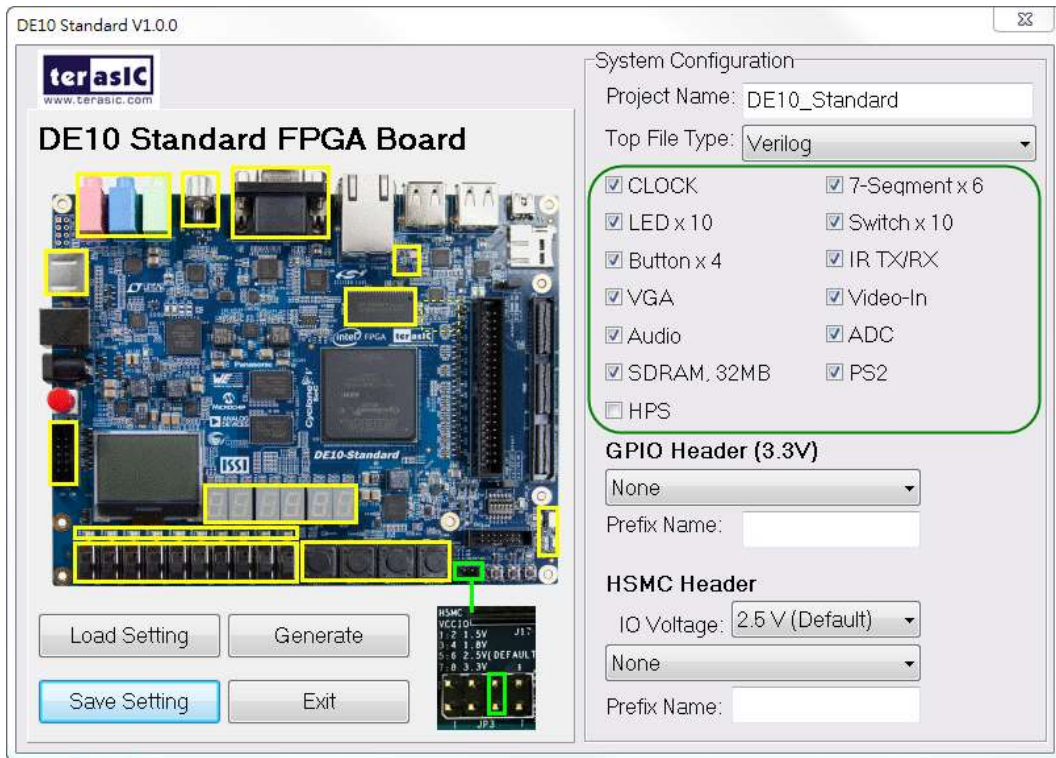

Figure 4-5 System configuration group

■ GPIO and HSMC Expansion

If users connect any Terasic GPIO-based or HSMC-based daughter cards to the GPIO connector or HSMC connector on DE10-Standard, the DE10-Standard System Builder can generate a project that include the corresponding module, as shown in [Figure 4-6](#). It will also generate the associated pin assignment automatically, including pin name, pin location, pin direction, and I/O standard.

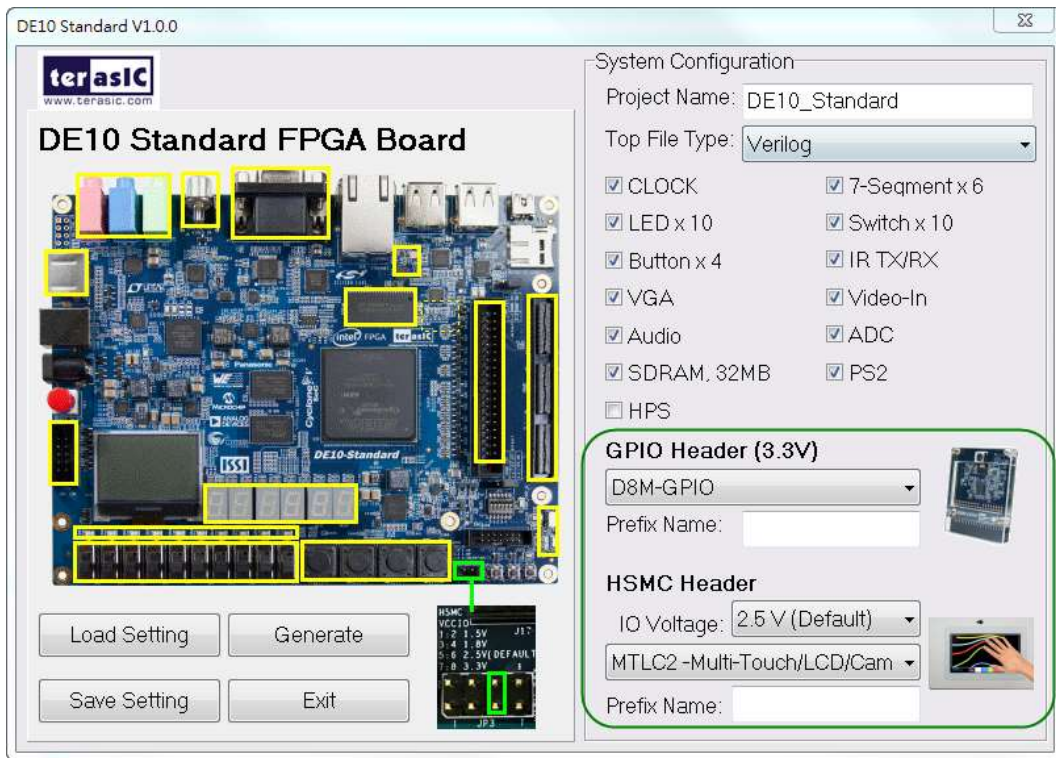

Figure 4-6 GPIO and HSMC expansion group

The “Prefix Name” is an optional feature that denotes the pin name of the daughter card assigned in your design. Users may leave this field blank.

■ Project Setting Management

The DE10-Standard System Builder also provides the option to load a setting or save users’ current board configuration in .cfg file, as shown in [Figure 4-7](#).

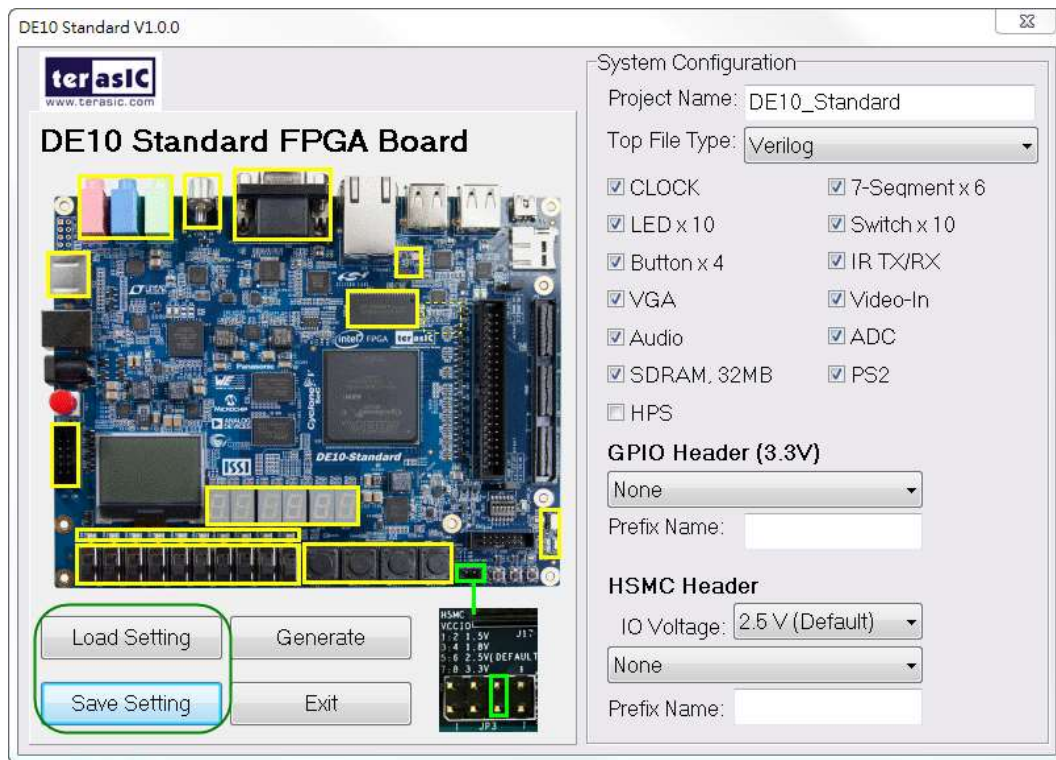

Figure 4-7 Project Settings

■ Project Generation

When users press the *Generate* button, the DE10-Standard System Builder will generate the corresponding Quartus II files and documents, as listed in [Table 4-1](#):

Table 4-1 Files generated by the DE10-Standard System Builder

No.	Filename	Description
1	<Project name>.v or .vhd	Top level Verilog or VHDL HDL file for Quartus II
2	<Project name>.qpf	Quartus II Project File
3	<Project name>.qsf	Quartus II Setting File
4	<Project name>.sdc	Synopsis Design Constraints file for Quartus II
5	<Project name>.htm	Pin Assignment Document

Users can add custom logic into the project in Quartus II and compile the project to generate the SRAM Object File (.sof).

This chapter provides examples of advanced designs implemented by RTL or Qsys on the DE10-Standard board. These reference designs cover the features of peripherals connected to the FPGA, such as audio, SDRAM, and IR receiver. All the associated files can be found in the directory \Demonstrations\FPGA of DE10-Standard System CD.

■ Installation of Demonstrations

To install the demonstrations on your computer:

Copy the folder Demonstrations to a local directory of your choice. It is important to make sure the path to your local directory contains NO space. Otherwise it will lead to error in Nios II. **Note, Quartus II v16.1 or later is required for all DE10-Standard demonstrations to support Cyclone V SoC device.**

5.1 DE10-Standard Factory Configuration

The DE10-Standard board has a default configuration bit-stream pre-programmed, which demonstrates some of the basic features onboard. The setup required for this demonstration and the location of its files are shown below.

■ Demonstration Setup, File Locations, and Instructions

- Project directory: DE10_Standard_Default
- Bitstream used: DE10_Standard_Default.sof or DE10_Standard_Default.jic
- Power on the DE10-Standard board with the USB cable connected to the USB-Blaster II port. If necessary (that is, if the default factory configuration is not currently stored in the EPCS device), download the bit stream to the board via JTAG interface.
- You should now be able to observe the 7-segment displays are showing a sequence of characters, and the red LEDs are blinking.
- If the VGA D-SUB connector is connected to a VGA display, it would show a color picture.
- If the stereo line-out jack is connected to a speaker and KEY[1] is pressed, a 1k Hz humming sound will come out of the line-out port.
- For the ease of execution, a demo_batch folder is provided in the project. It is able to not

only load the bit stream into the FPGA in command line, but also program or erase .jic file to the EPCS by executing the test.bat file shown in **Figure 5-1**.

If users want to program a new design into the EPCS device, the easiest method is to copy the new .sof file into the demo_batch folder and execute the test.bat. Option “2” will convert the .sof to .jic and option “3” will program .jic file into the EPCS device.

```
*****
Please choose your operation
"1" for programming .sof to FPGA.
"2" for converting .sof to .jic
"3" for programming .jic to EPCS.
"4" for erasing .jic from EPCS.
"5" for EXIT batch.
*****
Please enter your choice: [1,2,3,4,5]?_
```

Figure 5-1 Command line of the batch file to program the FPGA and EPCS device

5.2 Audio Recording and Playing

This demonstration shows how to implement an audio recorder and player on DE10-Standard board with the built-in audio CODEC chip. It is developed based on Qsys and Eclipse. **Figure 5-2** shows the buttons and slide switches used to interact this demonstration onboard. Users can configure this audio system through two push-buttons and four slide switches:

- SW0 is used to specify the recording source to be Line-in or MIC-In.
- SW1, SW2, and SW3 are used to specify the recording sample rate such as 96K, 48K, 44.1K, 32K, or 8K.
- **Table 5-1** and **Table 5-2** summarize the usage of slide switches for configuring the audio recorder and player.

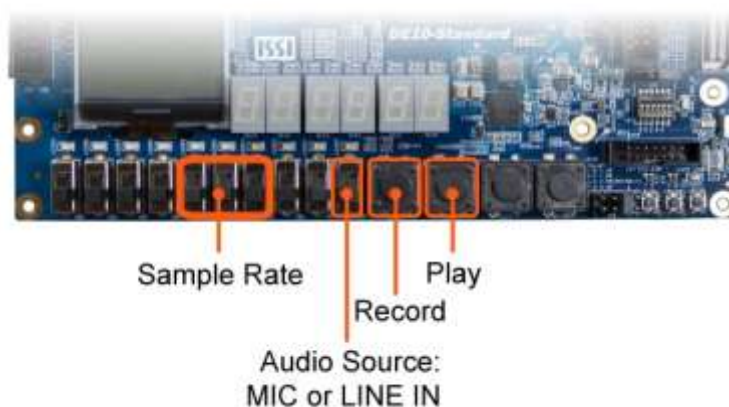

Figure 5-2 Buttons and switches for the audio recorder and player

Figure 5-3 shows the block diagram of audio recorder and player design. There are hardware and

software parts in the block diagram. The software part stores the Nios II program in the on-chip memory. The software part is built under Eclipse in C programming language. The hardware part is built under Qsys in Quartus II. The hardware part includes all the other blocks such as the “AUDIO Controller”, which is a user-defined Qsys component and it is designed to send audio data to the audio chip or receive audio data from the audio chip.

The audio chip is programmed through I2C protocol, which is implemented in C code. The I2C pins from the audio chip are connected to Qsys system interconnect fabric through PIO controllers. The audio chip is configured in master mode in this demonstration. The audio interface is configured as 16-bit I2S mode. 18.432MHz clock generated by the PLL is connected to the MCLK/XTI pin of the audio chip through the audio controller.

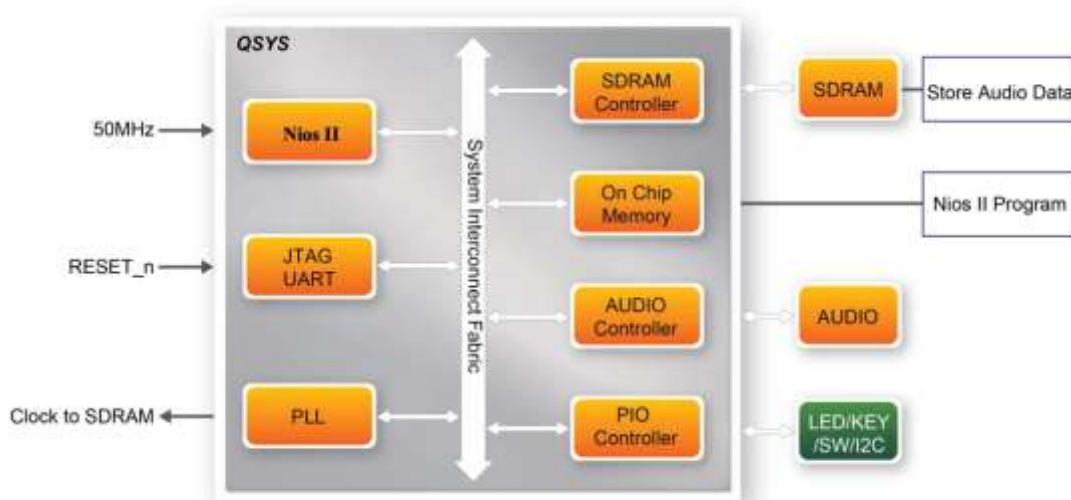

Figure 5-3 Block diagram of the audio recorder and player

■ Demonstration Setup, File Locations, and Instructions

- Hardware project directory: DE10_Standard_Audio
- Bitstream used: DE10_Standard_Audio.sof
- Software project directory: DE10_Standard_Audio\software
- Connect an audio source to the Line-in port
- Connect a Microphone to the MIC-in port
- Connect a speaker or headset to the Line-out port
- Load the bitstream into the FPGA (note *1)
- Load the software execution file into the FPGA (note *1)
- Configure the audio with SW0, as shown in **Table 5-1**
- Press KEY3 to start/stop audio recording (note *2)
- Press KEY2 to start/stop audio playing (note *3)

Table 5-1 Slide switches usage for audio source

Slide Switches	0 – DOWN Position	1 – UP Position
SW0	Audio is from MIC-in	Audio is from Line-in

Table 5-2 Settings of switches for the sample rate of audio recorder and player

SW5 (0 – DOWN; 1- UP)	SW4 (0 – DOWN; 1-UP)	SW3 (0 – DOWN; 1-UP)	Sample Rate
0	0	0	96K
0	0	1	48K
0	1	0	44.1K
0	1	1	32K
1	0	0	8K
Unlisted combination			96K



Note:

- (1). Execute DE10_Standard_Audio/demo_batch/test.bat to download .sof and .elf files.*
- (2). Recording process will stop if the audio buffer is full.*
- (3). Playing process will stop if the audio data is played completely.*

5.3 Karaoke Machine

This demonstration uses the microphone-in, line-in, and line-out ports on DE10-Standard to create a Karaoke machine. The WM8731 CODEC is configured in master mode. The audio CODEC generates AD/DA serial bit clock (BCK) and the left/right channel clock (LRCK) automatically. The I2C interface is used to configure the audio CODEC, as shown in **Figure 5-4**. The sample rate and gain of the CODEC are set in a similar manner, and the data input from the line-in port is then mixed with the microphone-in port. The result is sent out to the line-out port.

The sample rate is set to 48 kHz in this demonstration. The gain of the audio CODEC is reconfigured via I2C bus by pressing the pushbutton KEY0, cycling within ten predefined gain values (volume levels) provided by the device.

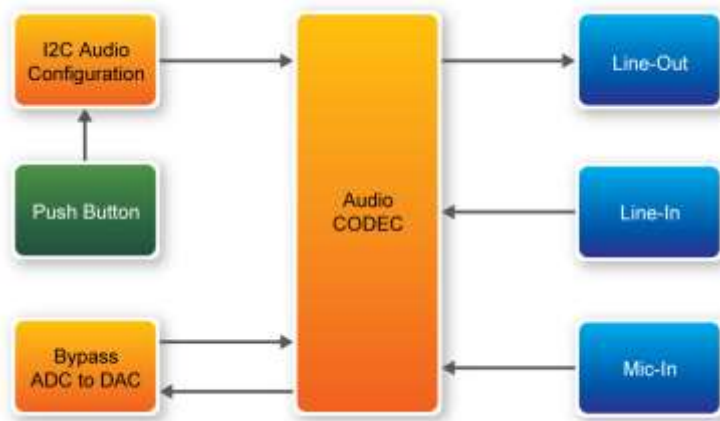

Figure 5-4 Block diagram of the Karaoke machine demonstration

■ Demonstration Setup, File Locations, and Instructions

- Project directory: DE10_Standard_i2sound
- Bitstream used: DE10_Standard_i2sound.sof
- Connect a microphone to the microphone-in port (pink color)
- Connect the audio output of a music player, such as a MP3 player or computer, to the line-in port (blue color)
- Connect a headset/speaker to the line-out port (green color)
- Load the bitstream into the FPGA by executing the batch file 'test.bat' in the directory DE10_Standard_i2sound\demo_batch
- Users should be able to hear a mixture of microphone sound and the sound from the music player
- Press KEY0 to adjust the volume; it cycles between volume level 0 to 9

Figure 5-5 illustrates the setup for this demonstration.

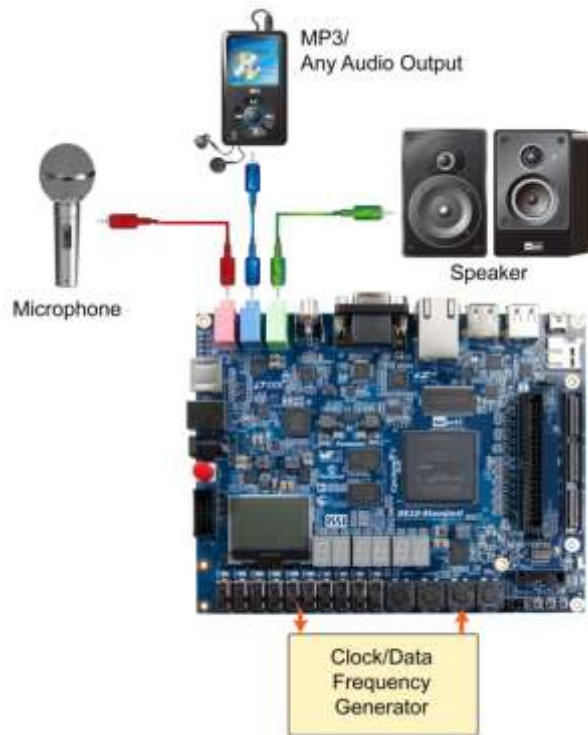

Figure 5-5 Setup for the Karaoke machine

5.4 SDRAM Test in Nios II

There are many applications use SDRAM as a temporary storage. Both hardware and software designs are provided to illustrate how to perform memory access in Qsys in this demonstration. It also shows how Intel's SDRAM controller IP accesses SDRAM and how the Nios II processor reads and writes the SDRAM for hardware verification. The SDRAM controller handles complex aspects of accessing SDRAM such as initializing the memory device, managing SDRAM banks, and keeping the devices refreshed at certain interval.

■ System Block Diagram

Figure 5-6 shows the system block diagram of this demonstration. The system requires a 50 MHz clock input from the board. The SDRAM controller is configured as a 64MB controller. The working frequency of the SDRAM controller is 100MHz, and the Nios II program is running on the on-chip memory.

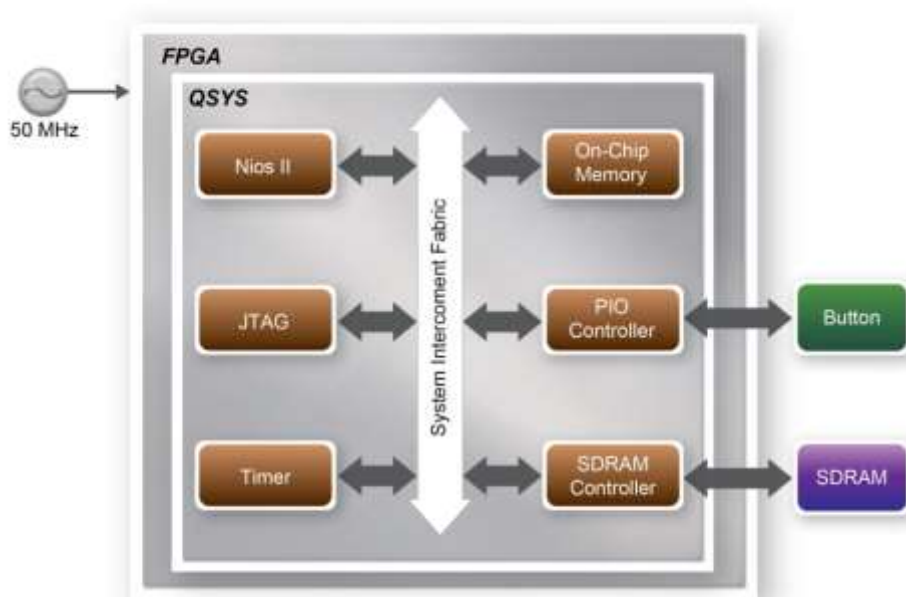

Figure 5-6 Block diagram of the SDRAM test in Nios II

The system flow is controlled by a program running in Nios II. The Nios II program writes test patterns into the entire 64MB of SDRAM first before calling the Nios II system function, `alt_dcache_flush_all`, to make sure all the data are written to the SDRAM. It then reads data from the SDRAM for data verification. The program will show the progress in Nios-terminal when writing/reading data to/from the SDRAM. When the verification process reaches 100%, the result will be displayed in Nios-terminal.

■ Design Tools

- Quartus II v16.1
- Nios II Eclipse v16.1

■ Demonstration Source Code

- Quartus project directory: `SDRAM_Nios_Test`
- Nios II Eclipse directory: `SDRAM_Nios_Test \Software`

■ Nios II Project Compilation

- Click “Clean” from the “Project” menu of Nios II Eclipse before compiling the reference

design in Nios II Eclipse

■ Demonstration Batch File

The files are located in the directory \SDRAM_Nios_Test\demo_batch.

The folder includes the following files:

- Batch file for USB-Blaster II : test.bat
- FPGA configuration file : SDRAM_Nios_Test.sof
- Nios II program: SDRAM_Nios_Test.elf

■ Demonstration Setup

- Quartus II v16.1 and Nios II v16.1 must be pre-installed on the host PC.
- Power on the DE10_Standard board.
- Connect the DE10_Standard board (J13) to the host PC with a USB cable and install the USB-Blaster II driver if necessary.
- Execute the demo batch file “ test.bat” from the directory SDRAM_Nios_Test\demo_batch
- After the program is downloaded and executed successfully, a prompt message will be displayed in nios2-terminal.
- Press any button (**KEY3~KEY0**) to start the SDRAM verification process. Press **KEY0** to run the test continuously.
- The program will display the test progress and result, as shown in **Figure 5-7**.

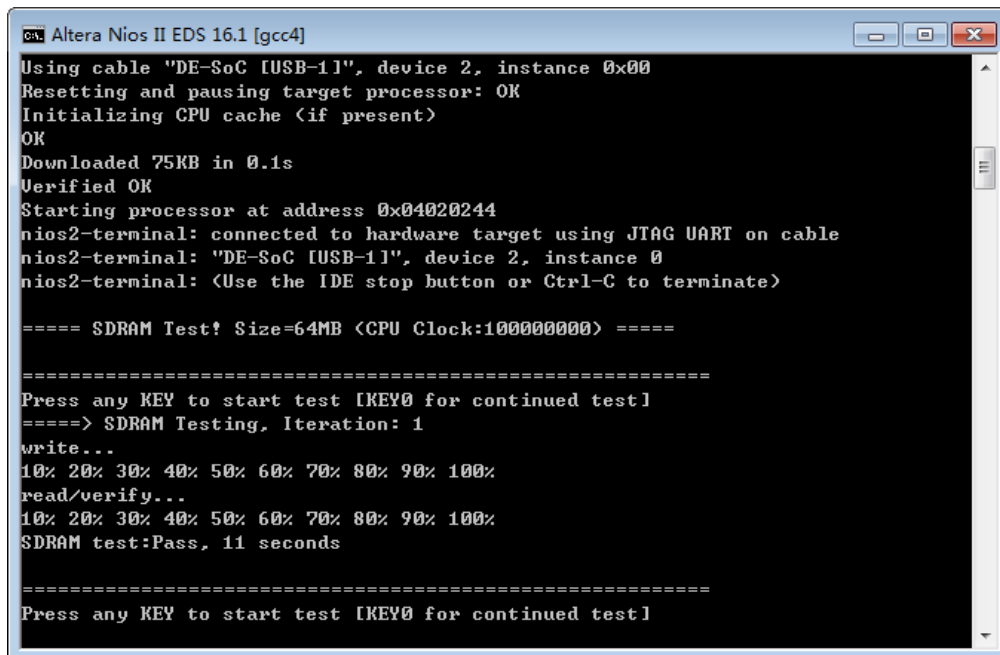

```
Altera Nios II EDS 16.1 [gcc4]
Using cable "DE-SoC [USB-1]", device 2, instance 0x00
Resetting and pausing target processor: OK
Initializing CPU cache <if present>
OK
Downloaded 75KB in 0.1s
Verified OK
Starting processor at address 0x04020244
nios2-terminal: connected to hardware target using JTAG UART on cable
nios2-terminal: "DE-SoC [USB-1]", device 2, instance 0
nios2-terminal: <Use the IDE stop button or Ctrl-C to terminate>

==== SDRAM Test! Size=64MB <CPU Clock:100000000> ====

=====
Press any KEY to start test [KEY0 for continued test]
====> SDRAM Testing, Iteration: 1
write...
10% 20% 30% 40% 50% 60% 70% 80% 90% 100%
read/verify...
10% 20% 30% 40% 50% 60% 70% 80% 90% 100%
SDRAM test:Pass, 11 seconds

=====
Press any KEY to start test [KEY0 for continued test]
```

Figure 5-7 Display of progress and result for the SDRAM test in Nios II

5.5 SDRAM Test in Verilog

DE10-Standard system CD offers another SDRAM test with its test code written in Verilog HDL. The memory size of the SDRAM bank tested is still 64MB.

■ Function Block Diagram

Figure 5-8 shows the function block diagram of this demonstration. The SDRAM controller uses 50 MHz as a reference clock and generates 100 MHz as the memory clock.

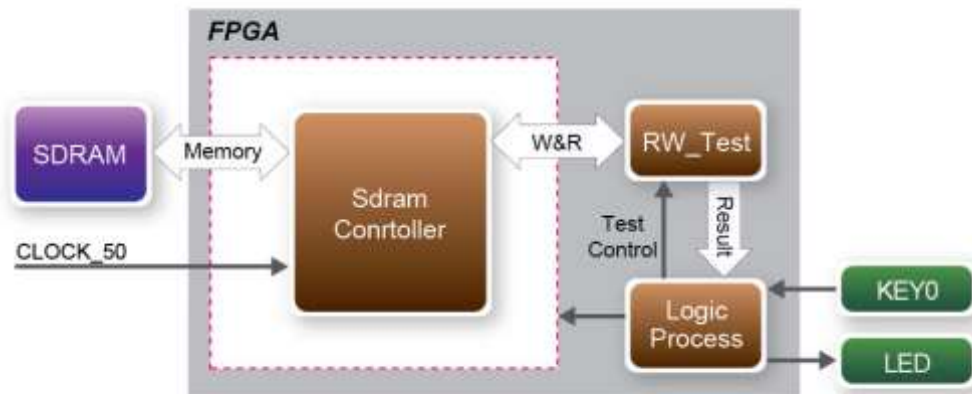

Figure 5-8 Block diagram of the SDRAM test in Verilog

RW_test module writes the entire memory with a test sequence first before comparing the data read back with the regenerated test sequence, which is same as the data written to the memory. KEY0 triggers test control signals for the SDRAM, and the LEDs will indicate the test result according to Table 5-3.

■ Design Tools

- Quartus II v16.1

■ Demonstration Source Code

- Project directory: DE10_Standard_DRAM_RTL_Test
- Bitstream used: DE10_Standard_DRAM_RTL_Test.sof

■ Demonstration Batch File

Demo batch file folder: \DE10_Standard_DRAM_RTL_Test\demo_batch

The directory includes the following files:

- Batch file: test.bat
- FPGA configuration file: DE10_Standard_DRAM_RTL_Test.sof

■ Demonstration Setup

- Quartus II v16.1 must be pre-installed to the host PC.
- Connect the DE10_Standard board (J13) to the host PC with a USB cable and install the USB-Blaster II driver if necessary
- Power on the DE1_SoC board.
- Execute the demo batch file “DE10_Standard_SDRAM_RTL_Test.bat” from the directory \DE10_Standard_SDRAM_RTL_Test\demo_batch.
- Press **KEY0** on the DE1_SoC board to start the verification process. When **KEY0** is pressed, the **LEDR** [2:0] should turn on. When **KEY0** is then released, **LEDR1** and **LEDR2** should start blinking.
- After approximately 8 seconds, **LEDR1** should stop blinking and stay ON to indicate the test is PASS. **Table 5-3** lists the status of **LED** indicators.
- If **LEDR2** is not blinking, it means 50MHz clock source is not working.
- If **LEDR1** failed to remain ON after approximately 8 seconds, the SDRAM test is NG.
- Press **KEY0** again to repeat the SDRAM test.

Table 5-3 Status of LED Indicators

Name	Description
LEDR0	Reset
LEDR1	ON if the test is PASS after releasing KEY0
LEDR2	Blinks

5.6 TV Box Demonstration

This demonstration turns DE10-Standard board into a TV box by playing video and audio from a DVD player using the VGA output, audio CODEC and the TV decoder on the DE10-Standard board. **Figure 5-9** shows the block diagram of the design. There are two major blocks in the system called I2C_AV_Config and TV_to_VGA. The TV_to_VGA block consists of the ITU-R 656 Decoder, SDRAM Frame Buffer, YUV422 to YUV444, YCbCr to RGB, and VGA Controller. The figure also shows the TV decoder (ADV7180) and the VGA DAC (ADV7123) chip used.

The register values of the TV decoder are used to configure the TV decoder via the I2C_AV_Config block, which uses the I2C protocol to communicate with the TV decoder. The TV decoder will be unstable for a time period upon power up, and the Lock Detector block is responsible for detecting this instability.

The ITU-R 656 Decoder block extracts YcrCb 4:2:2 (YUV 4:2:2) video signals from the ITU-R 656 data stream sent from the TV decoder. It also generates a data valid control signal, which indicates the valid period of data output. The video signal for the TV decoder is interlaced; de-interlacing needs to be performed on the data source. The SDRAM Frame Buffer and a field selection multiplexer (MUX), which is controlled by the VGA Controller, are used to perform the de-interlacing operation. The VGA Controller also generates data request and odd/even selection signals to the SDRAM Frame Buffer and field selection multiplexer (MUX). The YUV422 to YUV444 block converts the selected YcrCb 4:2:2 (YUV 4:2:2) video data to the YcrCb 4:4:4 (YUV 4:4:4) video data format.

Finally, the YcrCb_to_RGB block converts the YcrCb data into RGB data output. The VGA Controller block generates standard VGA synchronous signals VGA_HS and VGA_VS to enable the display on a VGA monitor.

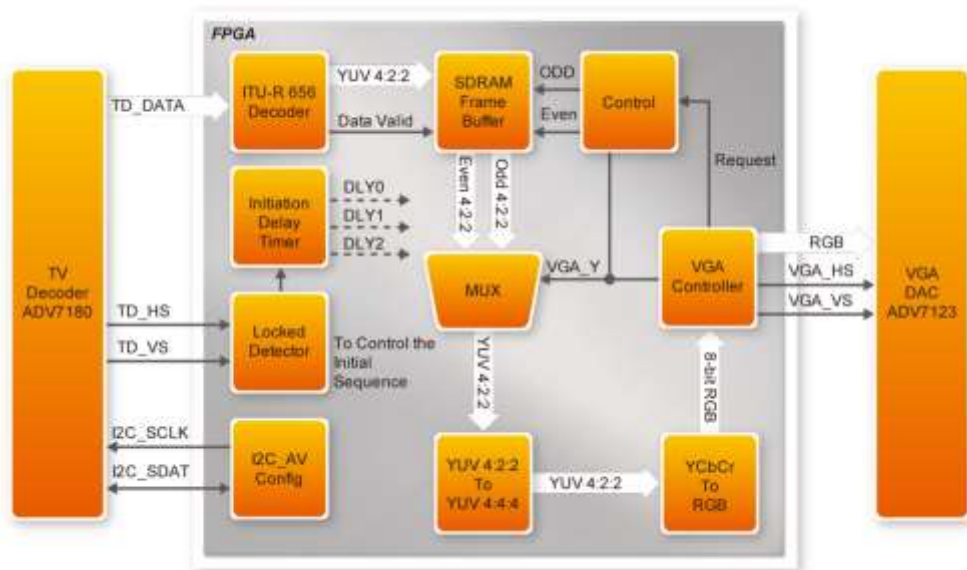

Figure 5-9 Block diagram of the TV box demonstration

■ Demonstration Source Code

- Project directory: DE10_Standard_TV
- Bitstream used: DE10_Standard_TV.sof

■ Demonstration Batch File

Demo batch directory: \DE10_Standard_TV\demo_batch

The folder includes the following files:

- Batch file: DE10_Standard_TV.bat
- FPGA configuration file : DE10_Standard_TV.sof

■ Demonstration Setup, File Locations, and Instructions

- Connect a DVD player's composite video output (yellow plug) to the Video-in RCA jack (J6) on the DE10_Standard board, as shown in **Figure 5-10**. The DVD player has to be configured to provide:
 - NTSC output
 - 60Hz refresh rate
 - 4:3 aspect ratio
 - Non-progressive video
- Connect the VGA output of the DE10_Standard board to a VGA monitor.
- Connect the audio output of the DVD player to the line-in port of the DE10_Standard board and connect a speaker to the line-out port. If the audio output jacks from the DVD player are RCA type, an adaptor is needed to convert to the mini-stereo plug supported on the DE10_Standard board.
- Load the bitstream into the FPGA by executing the batch file 'DE10_Standard_TV.bat' from the directory \DE10_Standard_TV\demo_batch\. Press KEY0 on the DE10_Standard board to reset the demonstration.

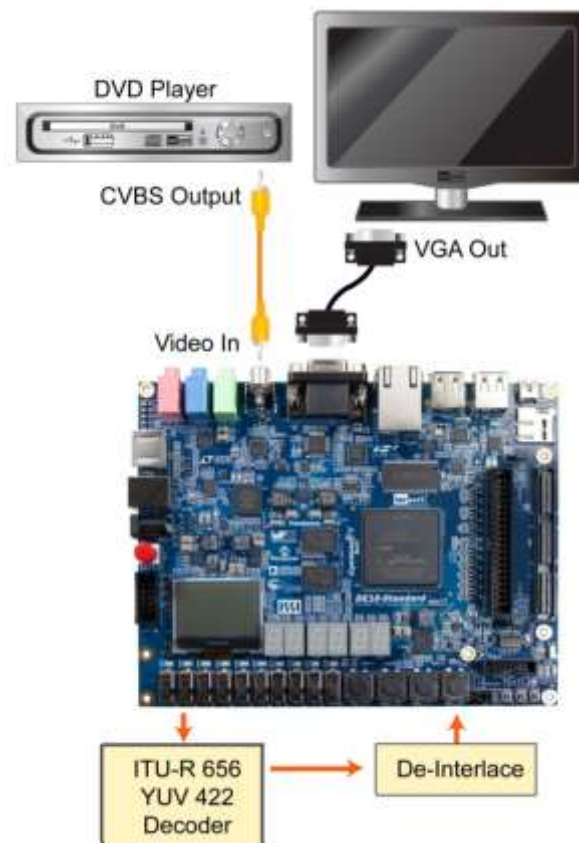

Figure 5-10 Setup for the TV box demonstration

5.7 TV Box Demonstration (VIP)

This section will demonstrate how to use Intel FPGA VIP (Video Image Processing) to turn the DE10-Standard board into a TV box allowing the users to play video and audio from a DVD player by using the VGA output, audio CODEC and the TV decoder on the DE10-Standard board.)

Figure 5-11 shows the block diagram of the design. There are two major blocks in the system: The I2C_AV_Config and Qsys/Vips. The Qsys/Vips block consists of a lot of Video and Image Processing (VIP) IPs, such as Clocked Video Input II, Color Plane Sequencer II, Deinterlacer II, Clipper II, Frame Buffer II, Chroma Resampler II, Color Space Converter II, Scaler II, and Clocked Video Output. The figure also shows the TV decoder (ADV7180) and the VGA DAC (ADV7123) chip that are used.

The register values of the TV decoder are used to configure the TV decoder via the I2C_AV_Config block, which uses the I2C protocol to communicate with the TV decoder. The TV decoder will be unstable for a short period of time upon power up, and the Lock Detector block is responsible for detecting this instability.

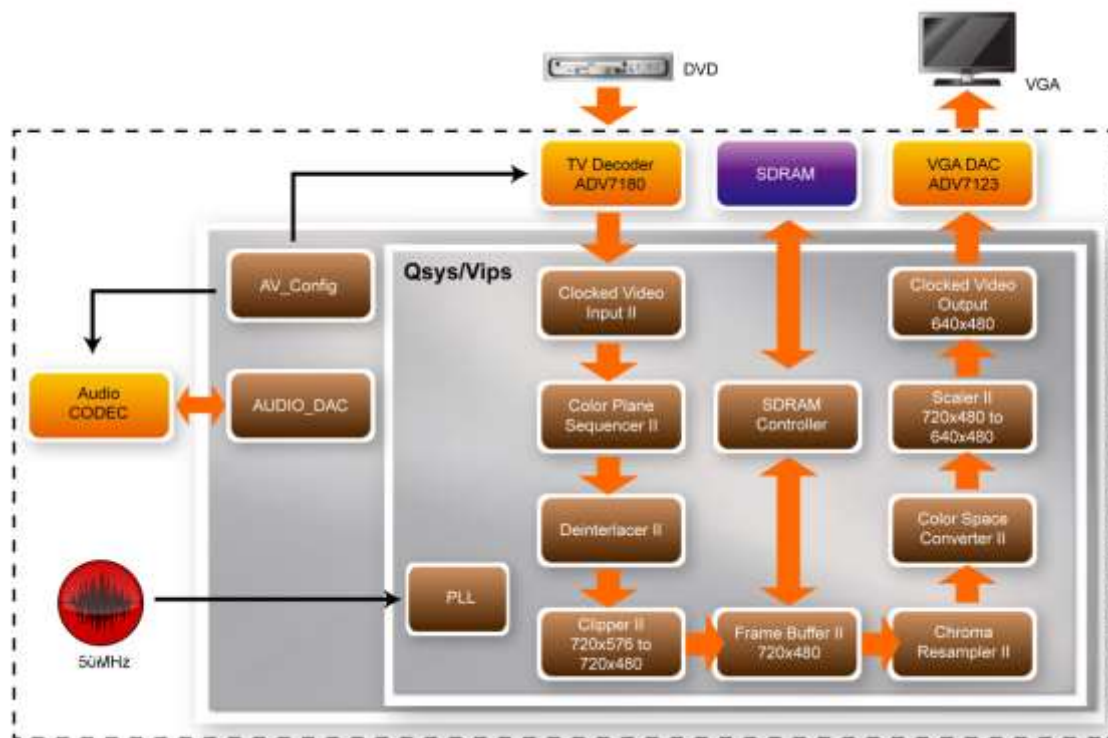

Figure 5-11 Block diagram of the TV box demonstration (VIP)

The Qsys/Vips process the fully streamed video from the TV decoder input to the VGA output.

The Clocked Video Input II: Converts clocked video formats to Avalon-ST Video.

(720x576, interlaced, Y'CbCr, 4:2:2 format)

Color Plane Sequencer II: Converts the two-sequence color plane to parallel.

Deinterlacer II: Deinterlacing the interlaced video from TV-input (PAL/NTSC) to progressive video for VGA-output.

Clipper II: Clip the video resolution from 720x576 to 720 x480.

Frame Buffer II: Buffers the video streams to SDRAM.

Chroma Resampler II: Resamples video data from 4:2:2 format to 4:4:4 format.

Color Space Converter II: Converts color space from Y'CbCr (digital television) to R'G'B'(computer monitors).

Scaler II: Scales the video resolution from 720x480 to 640 x480.

Clocked Video Output: Converts data from Avalon-ST Video protocol to clocked video.

■ Demonstration Source Code

- Project directory: DE10_Standard_VIP_TV
- Bitstream used: DE10_Standard_VIP_TV.sof

■ Demonstration Batch File

Demo batch directory: \DE10_Standard_VIP_TV\demo_batch

The folder includes the following files:

- Batch file: DE10_Standard_VIP_TV.bat
- FPGA configuration file : DE10_Standard_VIP_TV.sof



■ Demonstration Setup, File Locations, and Instructions

- Connect a DVD player's composite video output (yellow plug) to the Video-input RCA jack (J6) on the DE10_Standard board, as shown in **Figure 5-12**. The DVD player has to be configured to provide: NTSC or PAL output, 60Hz refresh rate, 4:3 aspect ratio, Non-progressive video
- Connect the VGA output of the DE10_Standard board to a VGA monitor.
- Optional, connect the audio output of the DVD player to the line-input port of the DE10_Standard board and connect a speaker to the line-output port. If the audio output jacks from the DVD player is RCA type, an adaptor is needed to convert to the mini-stereo plug supported on the DE10_Standard board.
- Load the bitstream into the FPGA by executing the batch file 'DE10_Standard_VIP_TV.bat' from the directory \DE10_Standard_VIP_TV\demo_batch\.
- Press KEY0 on the DE10_Standard board to reset the demonstration.
- The video will be displayed on the LCD Monitor.



Figure 5-12 Setup for the TV box demonstration (VIP)

5.8 PS/2 Mouse Demonstration

A simply PS/2 controller coded in Verilog HDL is provided to demonstrate bi-directional

communication with a PS/2 mouse. A comprehensive PS/2 controller can be developed based on it and more sophisticated functions can be implemented such as setting the sampling rate or resolution, which needs to transfer two data bytes at once.

More information about the PS/2 protocol can be found on various websites.

■ Introduction

PS/2 protocol uses two wires for bi-directional communication. One is the clock line and the other one is the data line. The PS/2 controller always has total control over the transmission line, but it is the PS/2 device which generates the clock signal during data transmission.

■ Data Transmission from Device to the Controller

After the PS/2 mouse receives an enabling signal at stream mode, it will start sending out displacement data, which consists of 33 bits. The frame data is cut into three sections and each of them contains a start bit (always zero), eight data bits (with LSB first), one parity check bit (odd check), and one stop bit (always one).

The PS/2 controller samples the data line at the falling edge of the PS/2 clock signal. This is implemented by a shift register, which consists of 33 bits.

easily be implemented using a shift register of 33 bits, but be cautious with the clock domain crossing problem.

■ Data Transmission from the Controller to Device

When the PS/2 controller wants to transmit data to device, it first pulls the clock line low for more than one clock cycle to inhibit the current transmission process or to indicate the start of a new transmission process, which is usually called as inhibit state. It then pulls low the data line before releasing the clock line. This is called the request state. The rising edge on the clock line formed by the release action can also be used to indicate the sample time point as for a 'start bit'. The device will detect this succession and generates a clock sequence in less than 10ms time. The transmit data consists of 12bits, one start bit (as explained before), eight data bits, one parity check bit (odd check), one stop bit (always one), and one acknowledge bit (always zero). After sending out the parity check bit, the controller should release the data line, and the device will detect any state change on the data line in the next clock cycle. If there's no change on the data line for one clock cycle, the device will pull low the data line again as an acknowledgement which means that the data is correctly received.

After the power on cycle of the PS/2 mouse, it enters into stream mode automatically and disable



data transmit unless an enabling instruction is received. **Figure 5-13** shows the waveform while communication happening on two lines.

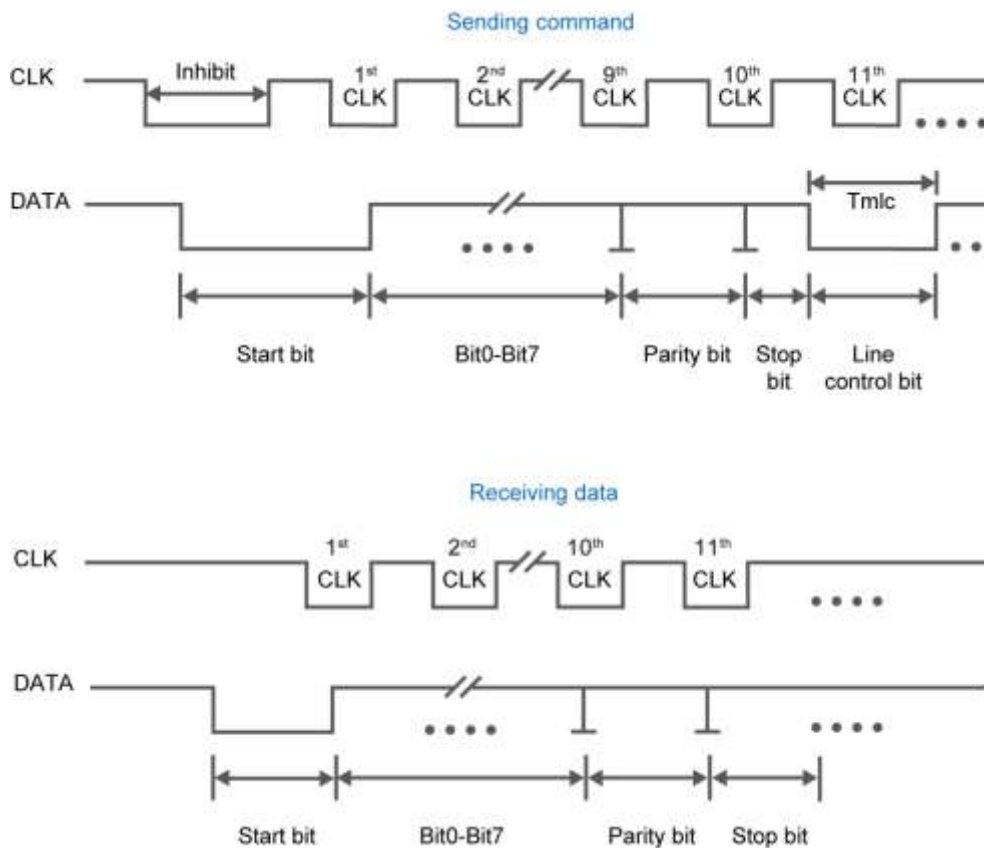

Figure 5-13 Waveform of clock and data signals during data transmission

Demonstration Source Code

- Project directory: DE10_Standard_PS2
- Bitstream used: DE10_Standard_PS2.sof

Demonstration Batch File

Demo batch file directoy: \DE10_Standard_PS2\demo_batch

The folder includes the following files:

- Batch file:test.bat
- FPGA configuration file : DE10_Standard_PS2.sof

Demonstration Setup, File Locations, and Instructions



- Load the bitstream into the FPGA by executing `\DE10_Standard_PS2\demo_batch\test.bat`
- Plug in the PS/2 mouse
- Press KEY[0] to enable data transfer
- Press KEY[1] to clear the display data cache
- The 7-segment display should change when the PS/2 mouse moves. The LEDR[2:0] will blink according to [Table 5-4](#) when the left-button, right-button, and/or middle-button is pressed.

Table 5-4 Description of 7-segment Display and LED Indicators

<i>Indicator Name</i>	<i>Description</i>
LEDR[0]	Left button press indicator
LEDR[1]	Right button press indicator
LEDR[2]	Middle button press indicator
HEX0	Low byte of X displacement
HEX1	High byte of X displacement
HEX2	Low byte of Y displacement
HEX3	High byte of Y displacement

5.9 IR Emitter LED and Receiver Demonstration

DE10_Standard system CD has an example of using the IR Emitter LED and IR receiver. This demonstration is coded in Verilog HDL.

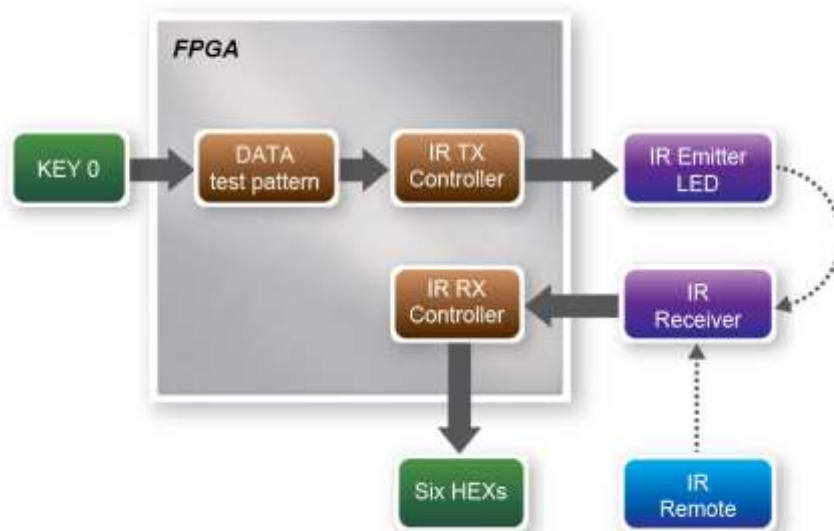

Figure 5-14 Block diagram of the IR emitter LED and receiver demonstration

Figure 5-14 shows the block diagram of the design. It implements a IR TX Controller and a IR RX Controller. When KEY0 is pressed, data test pattern generator will generate data to the IR TX Controller continuously. When IR TX Controller is active, it will format the data to be compatible

with NEC IR transmission protocol and send it out through the IR emitter LED. The IR receiver will decode the received data and display it on the six HEXs. Users can also use a remote control to send data to the IR Receiver. The main function of IR TX /RX controller and IR remote control in this demonstration is described in the following sections.

■ IR TX Controller

Users can input 8-bit address and 8-bit command into the IR TX Controller. The IR TX Controller will encode the address and command first before sending it out according to NEC IR transmission protocol through the IR emitter LED. The input clock of IR TX Controller should be 50MHz.

The NEC IR transmission protocol uses pulse distance to encode the message bits. Each pulse burst is 562.5µs in length with a carrier frequency of 38kHz (26.3µs).

Figure 5-15 shows the duration of logical “1” and “0”. Logical bits are transmitted as follows:

- Logical '0' – a 562.5µs pulse burst followed by a 562.5µs space with a total transmit time of 1.125ms
- Logical '1' – a 562.5µs pulse burst followed by a 1.6875ms space with a total transmit time of 2.25ms

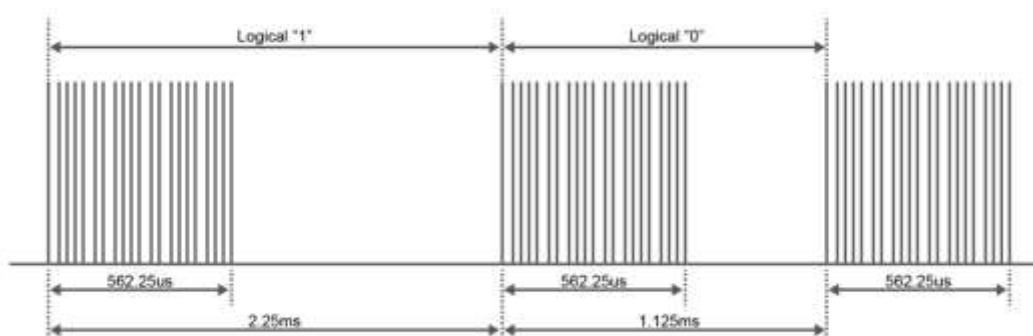

Figure 5-15 Duration of logical “1”and logical “0”

Figure 5-16 shows a frame of the protocol. Protocol sends a lead code first, which is a 9ms leading pulse burst, followed by a 4.5ms window. The second inversed data is sent to verify the accuracy of the information received. A final 562.5µs pulse burst is sent to signify the end of message transmission. Because the data is sent in pair (original and inverted) according to the protocol, the overall transmission time is constant.

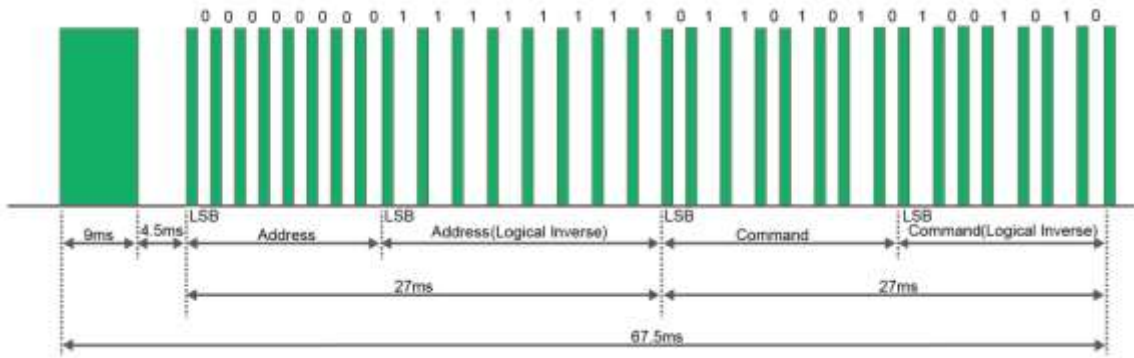

Figure 5-16 Typical frame of NEC protocol

Note: The signal received by IR Receiver is inverted. For instance, if IR TX Controller sends a lead code 9 ms high and then 4.5 ms low, IR Receiver will receive a 9 ms low and then 4.5 ms high lead code.

■ IR Remote

























When a key on the remote control shown in **Figure 5-17** is pressed, the remote control will emit a standard frame, as shown in **Table 5-5**. The beginning of the frame is the lead code, which represents the start bit, followed by the key-related information. The last bit end code represents the end of the frame. The value of this frame is completely inverted at the receiving end.



Figure 5-17 The remote control used in this demonstration

Table 5-5 Key Code Information for Each Key on the Remote Control

Key	Key Code	Key	Key Code	Key	Key Code	Key	Key Code
-----	----------	-----	----------	-----	----------	-----	----------

	0x0F		0x13		0x10		0x12
	0x01		0x02		0x03		0x1A
	0x04		0x05		0x06		0x1E
	0x07		0x08		0x09		0x1B
	0x11		0x00		0x17		0x1F
	0x16		0x14		0x18		0x0C

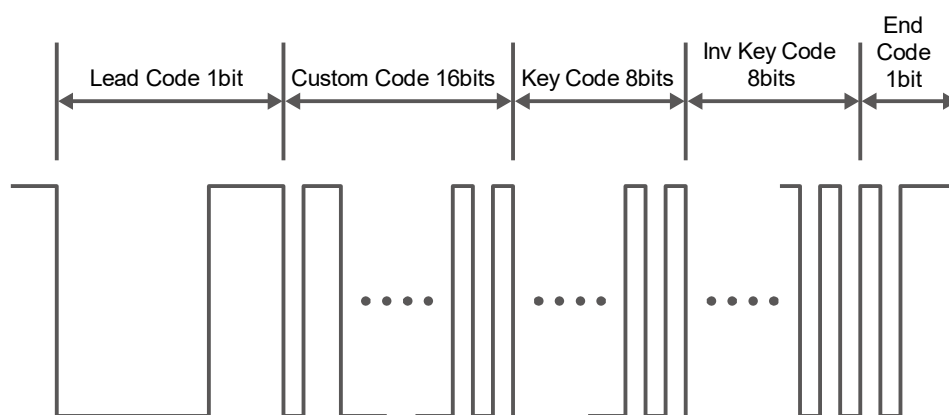

Figure 5-18 The transmitting frame of the IR remote control

■ IR RX Controller

The following demonstration shows how to implement the IP of IR receiver controller in the FPGA. **Figure 5-19** shows the modules used in this demo, including Code Detector, State Machine, and Shift Register. At the beginning the IR receiver demodulates the signal inputs to the Code Detector. The Code Detector will check the Lead Code and feedback the examination result to the State Machine.

The State Machine block will change the state from IDLE to GUIDANCE once the Lead Code is detected. If the Code Detector detects the Custom Code status, the current state will change from GUIDANCE to DATAREAD state. The Code Detector will also save the receiving data and output to the Shift Register and display on the 7-segment. **Figure 5-20** shows the state shift diagram of State Machine block. The input clock should be 50MHz.

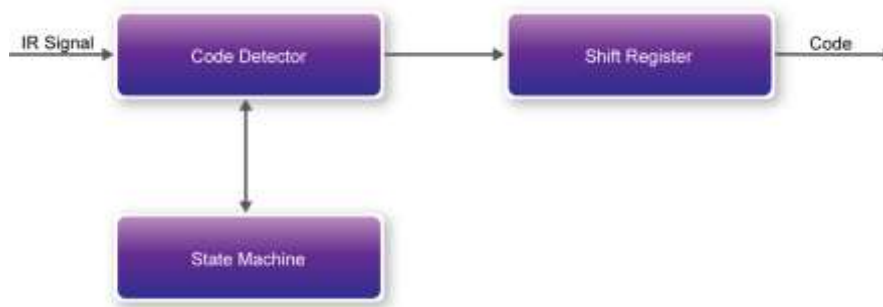

Figure 5-19 Modules in the IR Receiver controller

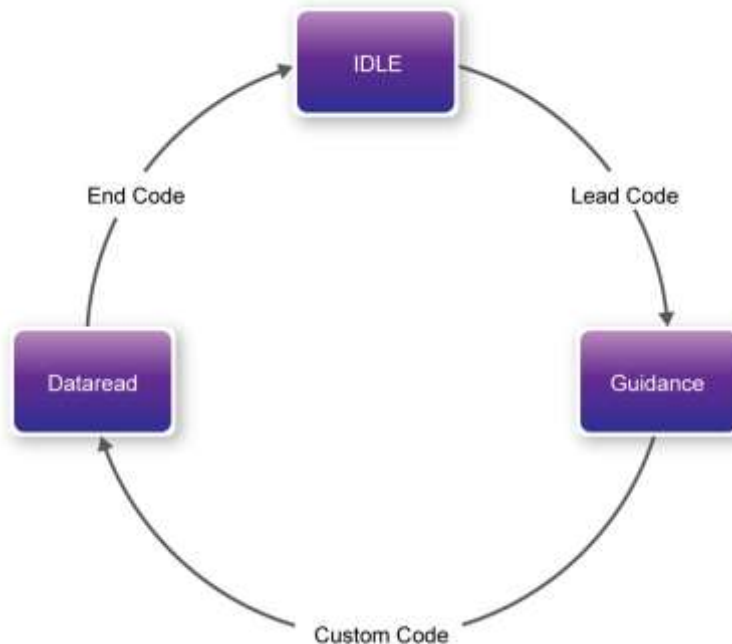

Figure 5-20 State shift diagram of State Machine block

Demonstration Source Code

- Project directory: DE10_Standard_IR
- Bitstream used: DE10_Standard_IR.sof

Demonstration Batch File

Demo batch file directory: DE10_Standard_IR \demo_batch

The folder includes the following files:

- Batch file: test.bat
- FPGA configuration file : DE10_Standard_IR.sof

Demonstration Setup, File Locations, and Instructions

- Load the bitstream into the FPGA by executing DE10_Standard_IR \demo_batch\ test.bat
- Keep pressing KEY[0] to enable the pattern to be sent out continuously by the IR TX

Controller.

- Observe the six HEXs according to [Table 5-6](#)
- Release KEY[0] to stop the IR TX.
- Point the IR receiver with the remote control and press any button
- Observe the six HEXs according to [Table 5-6](#)

Table 5-6 Detailed Information of the Indicators

<i>Indicator Name</i>	<i>Description</i>
HEX5	Inversed high byte of DATA(Key Code)
HEX4	Inversed low byte of DATA(Key Code)
HEX3	High byte of ADDRESS(Custom Code)
HEX2	Low byte of ADDRESS(Custom Code)
HEX1	High byte of DATA(Key Code)
HEX0	Low byte of DATA (Key Code)

5.10 ADC Reading

This demonstration illustrates steps to evaluate the performance of the 8-channel 12-bit A/D Converter LTC2308. The DC 5.0V on the 2x5 header is used to drive the analog signals by a trimmer potentiometer. The voltage should be adjusted within the range between 0 and 4.096V. The 12-bit voltage measurement is displayed on the NIOS II console. [Figure 5-21](#) shows the block diagram of this demonstration.

The default full-scale of ADC is 0~4.096V.

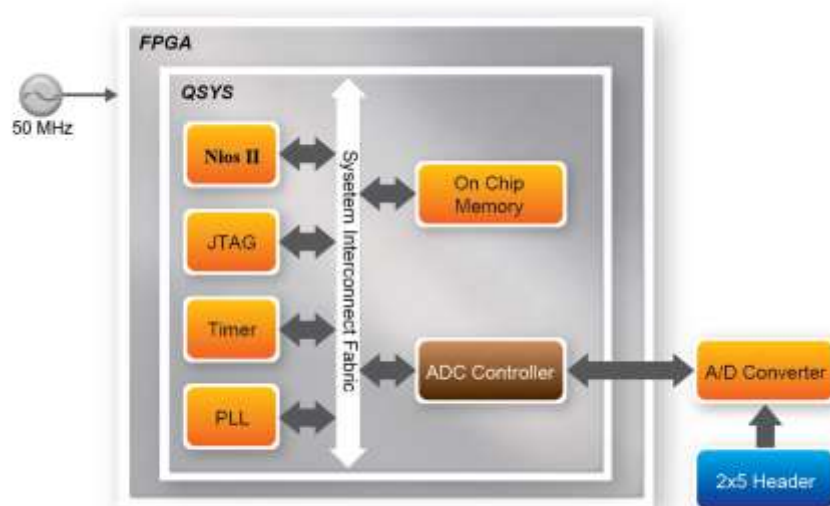

Figure 5-21 Block diagram of ADC reading

Figure 5-22 depicts the pin arrangement of the 2x5 header. This header is the input source of ADC convertor in this demonstration. Users can connect a trimmer to the specified ADC channel (ADC_IN0 ~ ADC_IN7) that provides voltage to the ADC convert. The FPGA will read the associated register in the convertor via serial interface and translates it to voltage value to be displayed on the Nios II console.

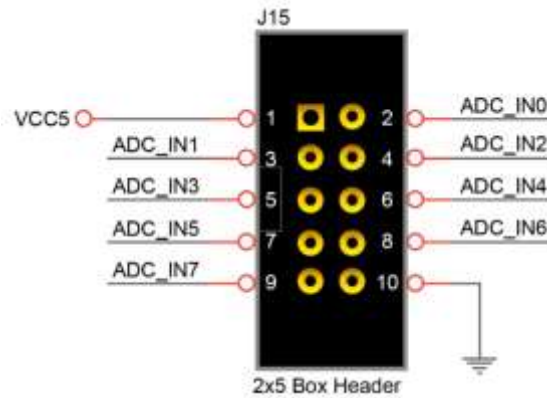

Figure 5-22 Pin distribution of the 2x5 Header for the ADC

The LTC2308 is a low noise, 500ksp/s, 8-channel, 12-bit ADC with an SPI/MICROWIRE compatible serial interface. The internal conversion clock allows the external serial output data clock (SCK) to operate at any frequency up to 40MHz. In this demonstration, we realized the SPI protocol in Verilog, and packet it into Avalon MM slave IP so that it can be connected to Qsys.

Figure 5-5-23 is SPI timing specification of LTC2308.

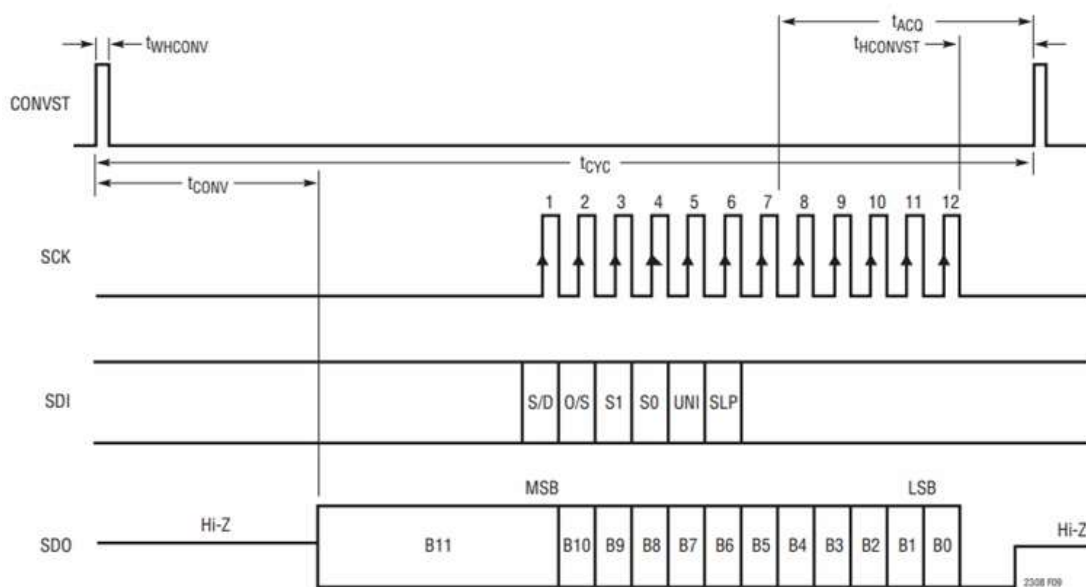

Figure 5-5-23 LTC2308 Timing with a Short CONVST Pulse

Important: Users should pay more attention to the impedance matching between the input source

and the ADC circuit. If the source impedance of the driving circuit is low, the ADC inputs can be driven directly. Otherwise, more acquisition time should be allowed for a source with higher impedance.

To modify acquisition time t_{ACQ} , user can change the $t_{HCONVST}$ macro value in `adc_ltc2308.v`. When SCK is set to 40MHz, it means 25ns per unit. The default $t_{HCONVST}$ is set to 320, achieving a 100KHz f_{sample} . Thus adding more $t_{HCONVST}$ time (by increasing $t_{HCONVST}$ macro value) will lower the sample rate of the ADC Converter.

```
`define tHCONVST      320
```

Figure 5-5-24 shows the example MUX configurations of ADC. In this demonstration, it is configured as 8 signal-end channel in the verilog code. User can change $SW[2:0]$ to measure the corresponding channel. The default reference voltage is 4.096V.

The formula of the sample voltage is:

$$\text{Sample Voltage} = \text{ADC Data} / \text{full scale Data} * \text{Reference Voltage.}$$

In this demonstration, full scale is $2^{12} = 4096$. Reference Voltage is 4.096V. Thus

$$\text{ADC Value} = \text{ADC data} / 4096 * 4.096 = \text{ADC data} / 1000$$

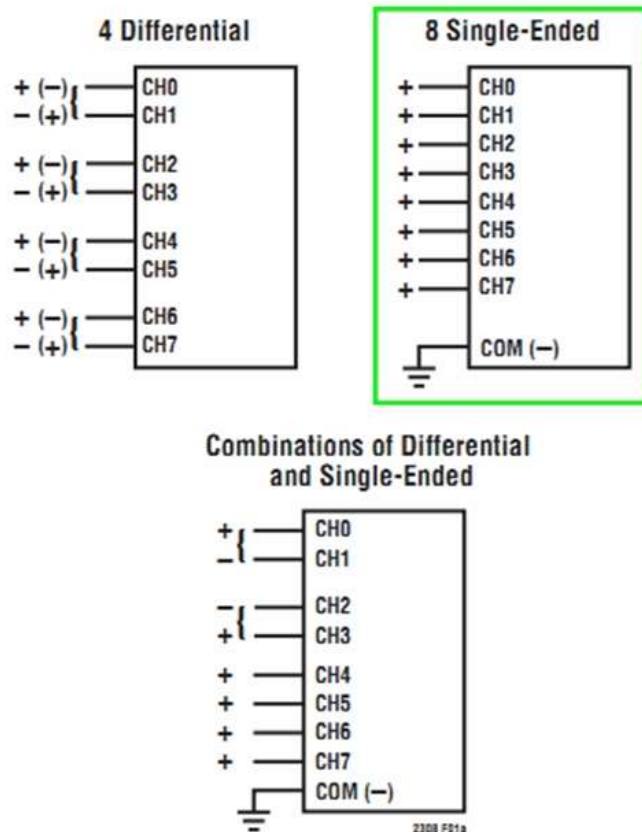

Figure 5-5-24 Example MUX Configurations

■ System Requirements

The following items are required for this demonstration.

- DE10_Standard board x1
- Trimmer Potentiometer x1
- Wire Strip x3

■ Demonstration File Locations

- Hardware project directory: DE10_Standard_ADC
- Bitstream used: DE10_Standard_ADC.sof
- Software project directory: DE10_Standard_ADC software
- Demo batch file : DE10_Standard_ADC\demo_batch\DE10_Standard_ADC.bat

■ Demonstration Setup and Instructions

- Connect the trimmer to corresponding ADC channel on the 2x5 header, as shown in **Figure 5-25**, as well as the +5V and GND signals. The setup shown above is connected to ADC channel 0.
- Execute the demo batch file DE10_Standard_ADC.bat to load the bitstream and software execution file to the FPGA.
- The Nios II console will display the voltage of the specified channel voltage result information.
- Provide any input voltage to other ADC channels and set SW[2:0] to the corresponding channel if user want to measure other channels

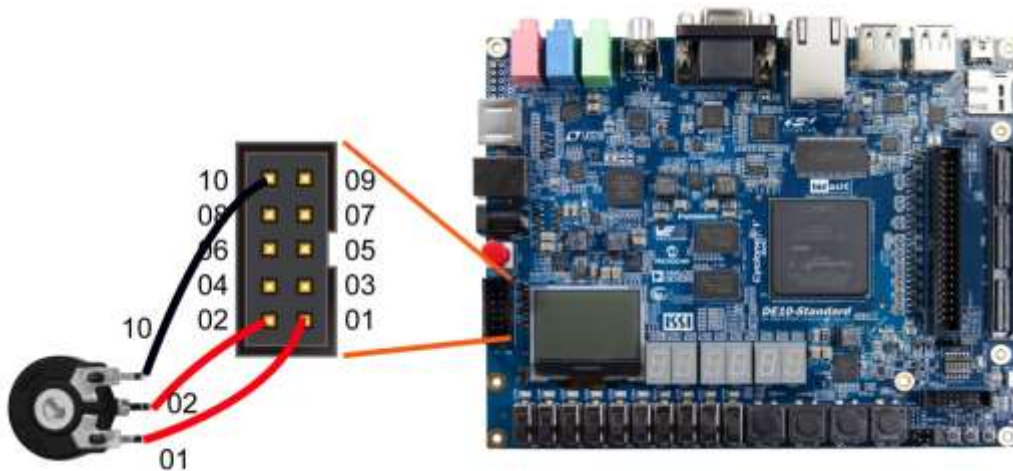

Figure 5-25 Hardware setup for the ADC reading demonstration

Chapter 6

Examples for HPS

SoC

This chapter provides several C-code examples based on the Intel SoC Linux built by Yocto project. These examples demonstrate major features connected to HPS interface on DE10-Standard board such as users LED/KEY, I2C interfaced G-sensor, and I2C MUX. All the associated files can be found in the directory *Demonstrations/SOC* of the DE10_Standard System CD. Please refer to Chapter 5 "**Running Linux on the DE10-Standard board**" from the *DE10-Standard_Getting_Started_Guide.pdf* to run Linux on DE10_Standard board.

■ Installation of the Demonstrations

To install the demonstrations on the host computer:

Copy the directory *Demonstrations* into a local directory of your choice. **Intel SoC EDS v16.1 is required for users to compile the c-code project.**

6.1 Hello Program

This demonstration shows how to develop first HPS program with Intel SoC EDS tool. Please refer to *My_First_HPS.pdf* from the system CD for more details.

The major procedures to develop and build HPS project are:

- Install Intel FPGA SoC EDS on the host PC.
- Create program .c/.h files with a generic text editor
- Create a "Makefile" with a generic text editor
- Build the project under Intel SoC EDS

■ Program File



The main program for the Hello World demonstration is:

```
#include <stdio.h>

int main(int argc, char **argv) {

    printf("Hello World!\r\n");

    return( 0 );
}
```

■ Makefile

A Makefile is required to compile a project. The Makefile used for this demo is:

```
#
TARGET = my_first_hps

ALT_DEVICE_FAMILY ?= soc_cv_av
SOCEDS_ROOT ?= $(SOCEDS_DEST_ROOT)
HWLIBS_ROOT = $(SOCEDS_ROOT)/ip/altera/hps/altera_hps/hwlib
CROSS_COMPILE = arm-linux-gnueabi-
CFLAGS = -g -Wall -D$(ALT_DEVICE_FAMILY) -I$(HWLIBS_ROOT)/include/$(ALT_DEVICE_FAMILY) -I$(HWLIBS_ROOT)/include/
LDFLAGS = -g -Wall
CC = $(CROSS_COMPILE)gcc
ARCH= arm

build: $(TARGET)

$(TARGET): main.o
    $(CC) $(LDFLAGS) $^ -o $@

%.o : %.c
    $(CC) $(CFLAGS) -c $< -o $@

.PHONY: clean
clean:
    rm -f $(TARGET) *.a *.o *~
```

■ Compile

Please launch SoC EDS Command Shell to compile a project by executing

```
C:\intelFPGA\16.1\embedded\Embedded_Command_Shell.bat
```

The "cd" command can change the current directory to where the Hello World project is located. The "make" command will build the project. The executable file "**my_first_hps**" will be generated after the compiling process is successful. The "clean all" command removes all temporary files.

■ Demonstration Source Code



- Build tool: SoC EDS v16.1
- Project directory: \Demonstration\SoC\my_first_hps
- Binary file: my_first_hps
- Build command: make ("**make clean**" to remove all temporary files)
- Execute command: ./my_first_hps

■ Demonstration Setup

- Connect a USB cable to the USB-to-UART connector (J4) on the DE10_Standard board and the host PC.
- Copy the demo file "**my_first_hps**" into a microSD card under the "**/home/root**" folder in Linux.
- Insert the booting microSD card into the DE10_Standard board.
- Power on the DE10_Standard board.
- Launch PuTTY and establish connection to the UART port of Putty. Type "**root**" to login Intel Yocto Linux.
- Type "**./my_first_hps**" in the UART terminal of PuTTY to start the program, and the "Hello World!" message will be displayed in the terminal.

```
root@socfpga:~# ./my_first_hps
Hello World!
root@socfpga:~# █
```

6.2 Users LED and KEY

This demonstration shows how to control the users LED and KEY by accessing the register of GPIO controller through the memory-mapped device driver. The memory-mapped device driver allows developer to access the system physical memory.

■ Function Block Diagram

Figure 6-1 shows the function block diagram of this demonstration. The users LED and KEY are connected to the **GPIO1** controller in HPS. The behavior of GPIO controller is controlled by the register in GPIO controller. The registers can be accessed by application software through the memory-mapped device driver, which is built into Intel SoC Linux.

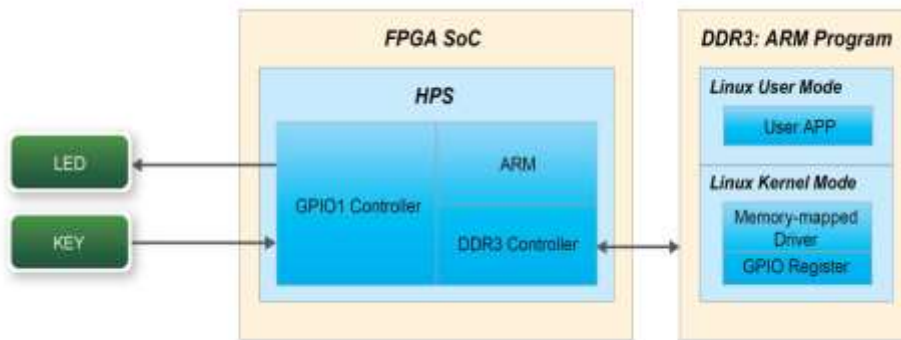

Figure 6-1 Block diagram of GPIO demonstration

■ Block Diagram of GPIO Interface

The HPS provides three general-purpose I/O (GPIO) interface modules. **Figure 6-2** shows the block diagram of GPIO Interface. GPIO[28..0] is controlled by the GPIO0 controller and GPIO[57..29] is controlled by the GPIO1 controller. GPIO[70..58] and input-only GPI[13..0] are controlled by the GPIO2 controller.

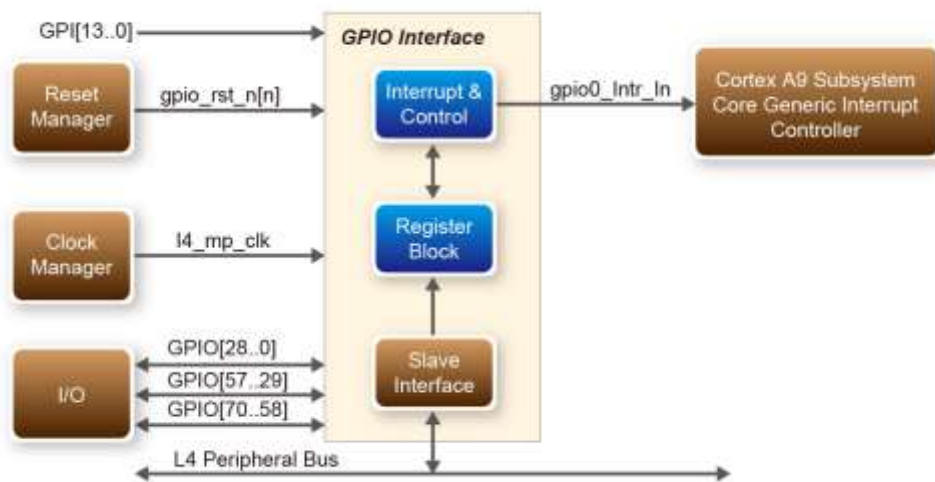

Figure 6-2 Block diagram of GPIO Interface

■ GPIO Register Block

The behavior of I/O pin is controlled by the registers in the register block. There are three 32-bit registers in the GPIO controller used in this demonstration. The registers are:

- **gpio_swporta_dr**: write output data to output I/O pin
- **gpio_swporta_ddr**: configure the direction of I/O pin
- **gpio_ext_porta**: read input data of I/O input pin

The `gpio_swporta_dds` configures the LED pin as output pin and drives it high or low by writing data to the `gpio_swporta_dr` register. The first bit (least significant bit) of `gpio_swporta_dr` controls the direction of first IO pin in the associated GPIO controller and the second bit controls the direction of second IO pin in the associated GPIO controller and so on. The value "1" in the register bit indicates the I/O direction is output, and the value "0" in the register bit indicates the I/O direction is input.

The first bit of `gpio_swporta_dr` register controls the output value of first I/O pin in the associated GPIO controller, and the second bit controls the output value of second I/O pin in the associated GPIO controller and so on. The value "1" in the register bit indicates the output value is high, and the value "0" indicates the output value is low.

The status of KEY can be queried by reading the value of `gpio_ext_porta` register. The first bit represents the input status of first IO pin in the associated GPIO controller, and the second bit represents the input status of second IO pin in the associated GPIO controller and so on. The value "1" in the register bit indicates the input state is high, and the value "0" indicates the input state is low.

■ GPIO Register Address Mapping

The registers of HPS peripherals are mapped to HPS base address space 0xFC000000 with 64KB size. The registers of the GPIO1 controller are mapped to the base address 0xFF708000 with 4KB size, and the registers of the GPIO2 controller are mapped to the base address 0xFF70A000 with 4KB size, as shown in **Figure 6-3**.

HPS
 Identifier: HPS
 Access: R/W
 Description: Address map for the HHP HPS system-domain

Title	Identifier	Offset
Reserved		0x0
QSPI Flash Controller Module Registers	QSPIREGS	0xFF705000
...		0xFF705100
...		0xFF705200
...		0xFF705300
...		0xFF705400
...		0xFF705500
...		0xFF705600
...		0xFF705700
...		0xFF705800
...		0xFF705900
...		0xFF705A00
...		0xFF705B00
...		0xFF705C00
...		0xFF705D00
...		0xFF705E00
...		0xFF705F00
...		0xFF706000
...		0xFF706100
...		0xFF706200
...		0xFF706300
...		0xFF706400
...		0xFF706500
...		0xFF706600
...		0xFF706700
...		0xFF706800
...		0xFF706900
...		0xFF706A00
...		0xFF706B00
...		0xFF706C00
...		0xFF706D00
...		0xFF706E00
...		0xFF706F00
...		0xFF707000
...		0xFF707100
...		0xFF707200
...		0xFF707300
...		0xFF707400
...		0xFF707500
...		0xFF707600
...		0xFF707700
...		0xFF707800
...		0xFF707900
...		0xFF707A00
...		0xFF707B00
...		0xFF707C00
...		0xFF707D00
...		0xFF707E00
...		0xFF707F00
...		0xFF708000
...		0xFF708100
...		0xFF708200
...		0xFF708300
...		0xFF708400
...		0xFF708500
...		0xFF708600
...		0xFF708700
...		0xFF708800
...		0xFF708900
...		0xFF708A00
...		0xFF708B00
...		0xFF708C00
...		0xFF708D00
...		0xFF708E00
...		0xFF708F00
...		0xFF709000
...		0xFF709100
...		0xFF709200
...		0xFF709300
...		0xFF709400
...		0xFF709500
...		0xFF709600
...		0xFF709700
...		0xFF709800
...		0xFF709900
...		0xFF709A00
...		0xFF709B00
...		0xFF709C00
...		0xFF709D00
...		0xFF709E00
...		0xFF709F00
...		0xFF70A000
...		0xFF70A100
...		0xFF70A200
...		0xFF70A300
...		0xFF70A400
...		0xFF70A500
...		0xFF70A600
...		0xFF70A700
...		0xFF70A800
...		0xFF70A900
...		0xFF70AA00
...		0xFF70AB00
...		0xFF70AC00
...		0xFF70AD00
...		0xFF70AE00
...		0xFF70AF00
...		0xFF70B000
...		0xFF70B100
...		0xFF70B200
...		0xFF70B300
...		0xFF70B400
...		0xFF70B500
...		0xFF70B600
...		0xFF70B700
...		0xFF70B800
...		0xFF70B900
...		0xFF70BA00
...		0xFF70BB00
...		0xFF70BC00
...		0xFF70BD00
...		0xFF70BE00
...		0xFF70BF00
...		0xFF70C000
...		0xFF70C100
...		0xFF70C200
...		0xFF70C300
...		0xFF70C400
...		0xFF70C500
...		0xFF70C600
...		0xFF70C700
...		0xFF70C800
...		0xFF70C900
...		0xFF70CA00
...		0xFF70CB00
...		0xFF70CC00
...		0xFF70CD00
...		0xFF70CE00
...		0xFF70CF00
...		0xFF70D000
...		0xFF70D100
...		0xFF70D200
...		0xFF70D300
...		0xFF70D400
...		0xFF70D500
...		0xFF70D600
...		0xFF70D700
...		0xFF70D800
...		0xFF70D900
...		0xFF70DA00
...		0xFF70DB00
...		0xFF70DC00
...		0xFF70DD00
...		0xFF70DE00
...		0xFF70DF00
...		0xFF70E000
...		0xFF70E100
...		0xFF70E200
...		0xFF70E300
...		0xFF70E400
...		0xFF70E500
...		0xFF70E600
...		0xFF70E700
...		0xFF70E800
...		0xFF70E900
...		0xFF70EA00
...		0xFF70EB00
...		0xFF70EC00
...		0xFF70ED00
...		0xFF70EE00
...		0xFF70EF00
...		0xFF70F000
...		0xFF70F100
...		0xFF70F200
...		0xFF70F300
...		0xFF70F400
...		0xFF70F500
...		0xFF70F600
...		0xFF70F700
...		0xFF70F800
...		0xFF70F900
...		0xFF70FA00
...		0xFF70FB00
...		0xFF70FC00
...		0xFF70FD00
...		0xFF70FE00
...		0xFF70FF00

Figure 6-3 GPIO address map

■ Software API

Developers can use the following software API to access the register of GPIO controller.

- open: open memory mapped device driver
- mmap: map physical memory to user space
- alt_read_word: read a value from a specified register
- alt_write_word: write a value into a specified register
- munmap: clean up memory mapping
- close: close device driver.

Developers can also use the following MACRO to access the register

- alt_setbits_word: set specified bit value to one for a specified register
- alt_clrbits_word: set specified bit value to zero for a specified register

The program must include the following header files to use the above API to access the registers of GPIO controller.

```
#include <stdio.h>
#include <unistd.h>
#include <fcntl.h>
#include <sys/mman.h>
#include "hwlib.h"
#include "socal/socal.h"
#include "socal/hps.h"
#include "socal/alt_gpio.h"
```

■ LED and KEY Control

Figure 6-4 shows the HPS users LED and KEY pin assignment for the DE1_SoC board. The LED is connected to HPS_GPIO53 and the KEY is connected to HPS_GPIO54. They are controlled by the GPIO1 controller, which also controls HPS_GPIO29 ~ HPS_GPIO57.

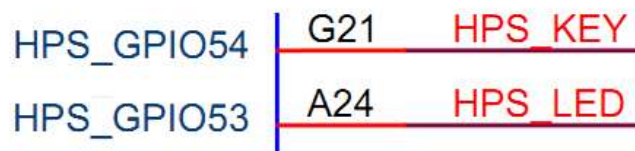

Figure 6-4 Pin assignment of LED and KEY

Figure 6-5 shows the `gpio_swporta_ddr` register of the GPIO1 controller. The bit-0 controls the pin direction of HPS_GPIO29. The bit-24 controls the pin direction of HPS_GPIO53, which

connects to HPS_LED, the bit-25 controls the pin direction of HPS_GPIO54, which connects to HPS_KEY and so on. The pin direction of HPS_LED and HPS_KEY are controlled by the bit-24 and bit-25 in the **gpio_swporta_ddr** register of the GPIO1 controller, respectively. Similarly, the output status of HPS_LED is controlled by the bit-24 in the **gpio_swporta_dr** register of the GPIO1 controller. The status of KEY can be queried by reading the value of the bit-24 in the **gpio_ext_porta** register of the GPIO1 controller.

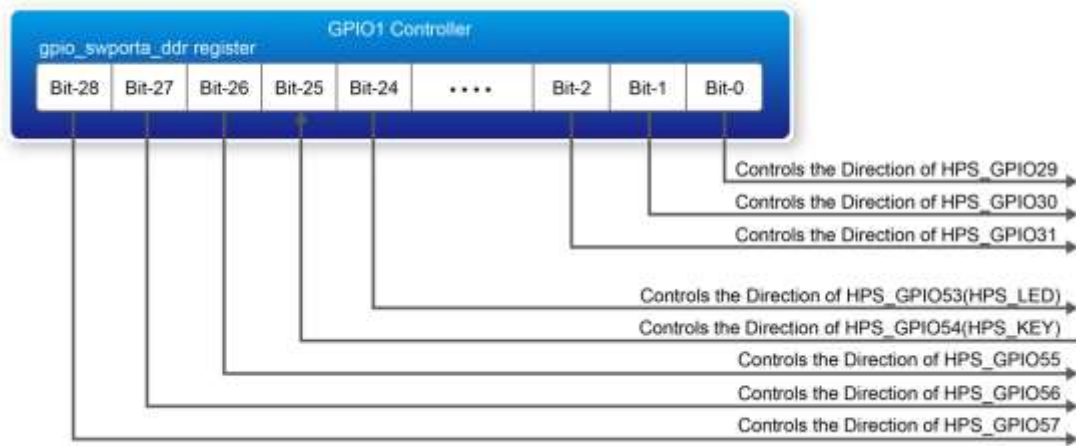

Figure 6-5 gpio_swporta_ddr register in the GPIO1 controller

The following mask is defined in the demo code to control LED and KEY direction and LED's output value.

```
#define USER_IO_DIR      (0x01000000)

#define BIT_LED          (0x01000000)

#define BUTTON_MASK     (0x02000000)
```

The following statement is used to configure the LED associated pins as output pins.

```
alt_setbits_word( ( virtual_base +
  (( uint32_t)( ALT_GPIO1_SWPORTA_DDR_ADDR ) &
  ( uint32_t)( HW_REGS_MASK ) ), USER_IO_DIR );
```

The following statement is used to turn on the LED.

```
alt_setbits_word( ( virtual_base +
  (( uint32_t)( ALT_GPIO1_SWPORTA_DR_ADDR ) &
  ( uint32_t)( HW_REGS_MASK ) ), BIT_LED );
```

The following statement is used to read the content of **gpio_ext_porta** register. The bit mask is used to check the status of the key.

```
alt_read_word( ( virtual_base +
( ( uint32_t)( ALT_GPIO1_EXT_PORTA_ADDR ) &
( uint32_t)( HW_REGS_MASK ) ) ) );
```

■ Demonstration Source Code

- Build tool: SoC EDS V16.1
- Project directory: \Demonstration\SoC\hps_gpio
- Binary file: hps_gpio
- Build command: make ('make clean' to remove all temporal files)
- Execute command: ./hps_gpio

■ Demonstration Setup

- Connect a USB cable to the USB-to-UART connector (J4) on the DE10_Standard board and the host PC.
- Copy the executable file "**hps_gpio**" into the microSD card under the **"/home/root"** folder in Linux.
- Insert the booting micro SD card into the DE10_Standard board.
- Power on the DE10_Standard board.
- Launch PuTTY and establish connection to the UART port of Putty. Type **"root"** to login Intel Yocto Linux.
- Type **"./hps_gpio "** in the UART terminal of PuTTY to start the program.

```
root@socfpga:~# ./hps_gpio
led test
the led flash 2 times
user key test
press key to control led
```

- HPS_LED will flash twice and users can control the user LED with push-button.
- Press HPS_KEY to light up HPS_LED.
- Press "CTRL + C" to terminate the application.

6.3 I2C Interfaced G-sensor

This demonstration shows how to control the G-sensor by accessing its registers through the built-in I2C kernel driver in [Intel Soc Yocto Powered Embedded Linux](#).

■ Function Block Diagram

Figure 6-6 shows the function block diagram of this demonstration. The G-sensor on the DE1_SoC board is connected to the I2C0 controller in HPS. The G-Sensor I2C 7-bit device address is 0x53. The system I2C bus driver is used to access the register files in the G-sensor. The G-sensor interrupt

signal is connected to the PIO controller. This demonstration uses polling method to read the register data.

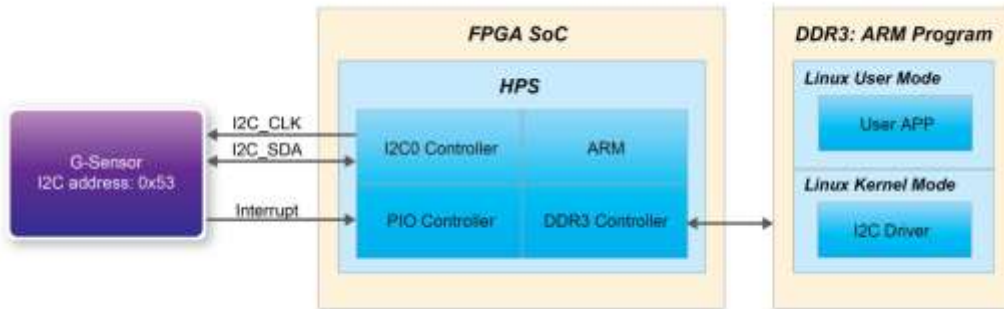

Figure 6-6 Block diagram of the G-sensor demonstration

■ I2C Driver

The procedures to read a register value from G-sensor register files by the existing I2C bus driver in the system are:

1. Open I2C bus driver "/dev/i2c-0": `file = open("/dev/i2c-0", O_RDWR);`
2. Specify G-sensor's I2C address 0x53: `ioctl(file, I2C_SLAVE, 0x53);`
3. Specify desired register index in g-sensor: `write(file, &Addr8, sizeof(unsigned char));`
4. Read one-byte register value: `read(file, &Data8, sizeof(unsigned char));`

The G-sensor I2C bus is connected to the I2C0 controller, as shown in the **Figure 6-7**. The driver name given is '/dev/i2c-0'.

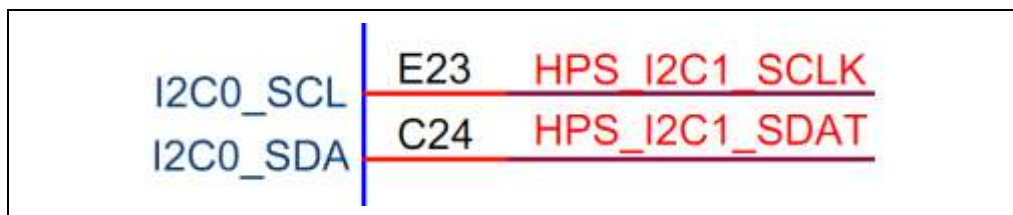

Figure 6-7 Connection of HPS I2C signals

The step 4 above can be changed to the following to write a value into a register.

```
write(file, &Data8, sizeof(unsigned char));
```

The step 4 above can also be changed to the following to read multiple byte values.

```
read(file, &szData8, sizeof(szData8)); // where szData is an array of bytes
```

The step 4 above can be changed to the following to write multiple byte values.

```
write(file, &szData8, sizeof(szData8)); // where szData is an array of bytes
```

■ G-sensor Control

The ADI ADXL345 provides I2C and SPI interfaces. I2C interface is selected by setting the CS pin to high on the DE1_SoC board.

The ADI ADXL345 G-sensor provides user-selectable resolution up to 13-bit \pm 16g. The resolution can be configured through the DATA_FORMAT(0x31) register. The data format in this demonstration is configured as:

- Full resolution mode
- \pm 16g range mode
- Left-justified mode

The X/Y/Z data value can be derived from the DATA0(0x32), DATA1(0x33), DATAY0(0x34), DATAY1(0x35), DATAZ0(0x36), and DATA1(0x37) registers. The DATA0 represents the least significant byte and the DATA1 represents the most significant byte. It is recommended to perform multiple-byte read of all registers to prevent change in data between sequential registers read. The following statement reads 6 bytes of X, Y, or Z value.

```
read(file, szData8, sizeof(szData8)); // where szData is an array of six-bytes
```

■ Demonstration Source Code

- Build tool: SoC EDS v16.1
- Project directory: \Demonstration\SoC\hps_gsensor
- Binary file: gsensor
- Build command: make ('make clean' to remove all temporal files)
- Execute command: ./gsensor [loop count]

■ Demonstration Setup

- Connect a USB cable to the USB-to-UART connector (J4) on the DE10_Standard board and the host PC.
- Copy the executable file "**gsensor**" into the microSD card under the "**/home/root**" folder in Linux.
- Insert the booting microSD card into the DE10_Standard board.
- Power on the DE10_Standard board.
- Launch PuTTY to establish connection to the UART port of DE10_Standard board. Type



"root" to login Yocto Linux.

- Execute `./gsensor` in the UART terminal of PuTTY to start the G-sensor polling.
- The demo program will show the X, Y, and Z values in the PuTTY, as shown in **Figure 6-8**.

```
root@socfpga:~# ./gsensor
===== gsensor test =====
id=E5h
[1]X=80 mg, Y=-40 mg, Z=924 mg
[2]X=76 mg, Y=-32 mg, Z=972 mg
[3]X=76 mg, Y=-36 mg, Z=964 mg
[4]X=84 mg, Y=-36 mg, Z=976 mg
[5]X=76 mg, Y=-40 mg, Z=964 mg
[6]X=76 mg, Y=-40 mg, Z=972 mg
```

Figure 6-8 Terminal output of the G-sensor demonstration

- Press "CTRL + C" to terminate the program.

6.4 I2C MUX Test

The I2C bus on DE10-Standard is originally accessed by FPGA only. This demonstration shows how to switch the I2C multiplexer for HPS to access the I2C bus.

■ Function Block Diagram

Figure 6-9 shows the function block diagram of this demonstration. The I2C bus from both FPGA and HPS are connected to an I2C multiplexer. It is controlled by HPS_I2C_CONTROL, which is connected to the **GPIO1** controller in HPS. The HPS I2C is connected to the **I2C0** controller in HPS, as well as the G-sensor.

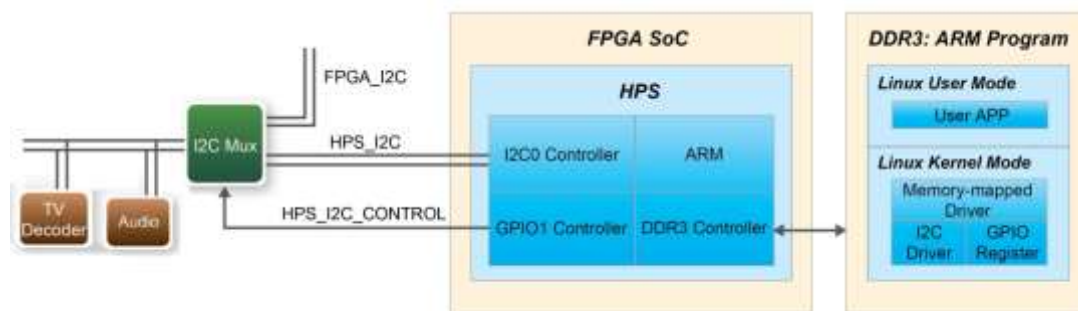

Figure 6-9 Block diagram of the I2C MUX test demonstration

■ HPS_I2C_CONTROL Control

HPS_I2C_CONTROL is connected to HPS_GPIO48, which is bit-19 of the **GPIO1** controller. Once HPS gets access to the I2C bus, it can then access Audio CODEC and TV Decoder when the HPS_I2C_CONTROL signal is set to high.

The following mask in the demo code is defined to control the direction and output value of HPS_I2C_CONTROL.

```
#define HPS_I2C_CONTROL ( 0x00080000 )
```

The following statement is used to configure the HPS_I2C_CONTROL associated pins as output pin.

```
alt_setbits_word( ( virtual_base +  
( ( uint32_t)( ALT_GPIO1_SWPORTA_DDR_ADDR ) &  
( uint32_t)( HW_REGS_MASK ) ), HPS_I2C_CONTROL );
```

The following statement is used to set HPS_I2C_CONTROL high.

```
alt_setbits_word( ( virtual_base +  
( ( uint32_t)( ALT_GPIO1_SWPORTA_DR_ADDR ) &  
( uint32_t)( HW_REGS_MASK ) ), HPS_I2C_CONTROL );
```

The following statement is used to set HPS_I2C_CONTROL low.

```
alt_clrbits_word( ( virtual_base +  
( ( uint32_t)( ALT_GPIO1_SWPORTA_DR_ADDR ) &  
( uint32_t)( HW_REGS_MASK ) ), HPS_I2C_CONTROL );
```

■ I2C Driver

The procedures to read register value from TV Decoder by the existing I2C bus driver in the system are:

- Set HPS_I2C_CONTROL high for HPS to access I2C bus.
- Open the I2C bus driver `"/dev/i2c-0": file = open("/dev/i2c-0", O_RDWR);`
- Specify the I2C address 0x20 of ADV7180: `ioctl(file, I2C_SLAVE, 0x20);`
- Read or write registers;
- Set HPS_I2C_CONTROL low to release the I2C bus.

■ Demonstration Source Code

- Build tool: Intel SoC EDS v16.1
- Project directory: `\Demonstration\SoC\hps_i2c_switch`
- Binary file: `i2c_switch`
- Build command: `make ('make clean' to remove all temporal files)`
- Execute command: `./ i2c_switch`

■ Demonstration Setup



- Connect a USB cable to the USB-to-UART connector (J4) on the DE10_Standard board and host PC.
- Copy the executable file " **i2c_switch** " into the microSD card under the "**/home/root**" folder in Linux.
- Insert the booting microSD card into the DE10_Standard board.
- Power on the DE10_Standard board.
- Launch PuTTY to establish connection to the UART port of DE1_SoC board. Type "**root**" to login Yocto Linux.
- Execute "**./i2c_switch** " in the UART terminal of PuTTY to start the I2C MUX test.
- The demo program will show the result in the Putty, as shown in **Figure 6-10**.

```

root@socfpga:~# ./i2c_switch
I2C BUS Switch Test
HPS owns the I2C bus!!!
Open '/dev/i2c-0' successfully.
REG[11h]=1Ch (i2c addr:20h)
HPS release the I2C bus!!!
I2C Switch Test:Success
root@socfpga:~#

```

Figure 6-10 Terminal output of the I2C MUX Test Demonstration

- Press "CTRL + C" to terminate the program.

6.5 SPI Interfaced Graphic LCD

This demonstration shows how to control the Graphic LCD by using the HPS SPIM (SPI Master) controller and HPS GPIO controllers.

■ Function Block Diagram

Figure 6-9 shows the function block diagram of this demonstration. The LCD is connected to the **SPIM0**, **GPIO1** controller in HPS on this DE10-Standard board. The built-in virtual memory-mapped device driver in the system is used to access the registers in the HPS SPIM and GPIO controllers. The SPI interface is used to transfer Data or Command from HPS to LCD. Because the LCD is write-only, only three SPI signals **LCM_SPIM_CLK**, **LCM_SPIM_SS**, and **LCM_SPIM_MOSI** are required. The **LCM_D_C** signal is used to indicate the signal transferred on the SPI bus is Data or Command. When **LCM_D_C** signal is pulled high, it means the signal on SPI bus is Data. When **LCM_D_C** signal is pulled low, it means the signal on SPI bus is Command. The **LCD_RST_n** is the reset control signal of LCD. This signal is low active. The **LCM_BK** signal is used to turn on/off the black light of the LCD. When this signal is pulled high, LCD backlight is turned on.

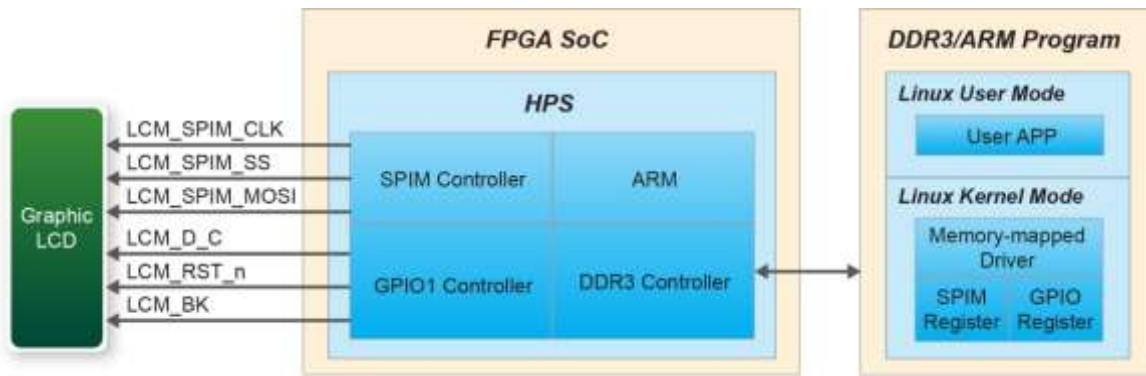

Figure 6-11 Block Diagram of the Graphic LCD Demonstration

■ LCD Control

Developer needs to initialize the LCD before sending any display data. The initialization includes:

- Common output mode select (Code: 0xC0~0xCF)
- Power control set (Code: 0x28~0x2F)
- Display start line set (Code: 0x40~0x7F)
- Page address set (Code: 0xB0~0xB8)
- Column address set (Code: 0x00 to 0x18)
- Display ON/OFF (Code: 0xAE~0xAF)

For details of command sets, please refer to the NT7534 datasheet in the System CD. After the LCD is initialized, developer can start transferring display data. Due to the display area is divided into 8 page, developer must first specify target page and column address before starting to transfer display data. **Figure 6-12** shows the relationship between image data bits and LCD display pixels when page = 0, column = 0, and start line = 0.

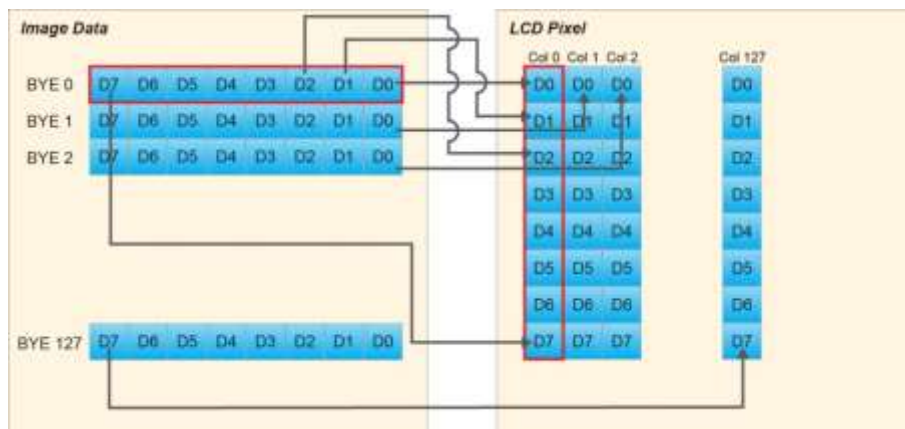

Figure 6-12 Relation between LCD display pixel and image data bits

■ SPIM Controller

In this demonstration, the HPS SPIM0 controller is configured as TX-Only SPI with clock rate 3.125MHz. Please refer to the function "LCDHW_Init" in LCD_Hw.c for details. The header file "socal/alt_spim.h", which needs to be included into the SPI controller program, defines all necessary constants for the SPIM controller.

■ C-code Explanation

This demonstration includes the following major files:

- LCD_HW.c: Low-level SPI and GPIO API to access LCD hardware
- LCD_Driver.c: LCD configuration API
- LCD_Lib.c: Top-level LCD control API
- lcd_graphic.c: Graphic and font APIs for LCD
- font.c: Font bitmap resource used by lcd_graphic.c
- main.c: Main program for this demonstration

The main program main.c calls "LCDHW_Init" to initialize the SPIM0 and GPIO controllers, which are used to control the LCD. It then calls "LCDHW_BackLight" to turn on the backlight of LCD. "LCD_Init" is called to initialize LCD configuration. Finally, the APIs in lcd_graphic.c are called to draw graphic on the LCD.

APIs in lcd_graphic.c don't drive LCD to draw graphic pixels directly. All graphic pixels are stored in a temporary image buffer called "Canvas". When API "DRAW_Refresh" is called, all drawing data in the Canvas is transferred to LCD. In this demonstration, main program calls "DRAW_Clear" to clear LCD Canvas first. "DRAW_Rect" and "DRAW_Circle" are called to draw geometry in Canvas. "DRAW_PrintString" is called to draw font in Canvas. Finally, "DRAW_Refresh" is called to move Canvas data onto LCD.

■ Demonstration Source Code

- Build tool: SoC EDS v16.1
- Project directory: \Demonstration\SoC\hps_lcd
- Binary file: hps_lcd
- Build command: make ("make clean" to remove all temporary files)
- Execute command: ./hps_lcd

■ Demonstration Setup

- Connect the USB cable to the USB-to-UART connector (J4) on the DE10-Standard board and host PC.
- Make sure the executable file "**hps_lcd**" is copied into the SD card under the /home/root folder in Linux.
- Insert the booting micro SD card into the DE10-Standard board.



- Power on the DE10-Standard t board.
- Launch PuTTY to connect to the UART port of DE10-Standard board and type "**root**" to login Yocto Linux.
- In the UART terminal of PuTTY, type "**./hps_lcd**" to start the LCD demo, as shown in **Figure 6-13**.

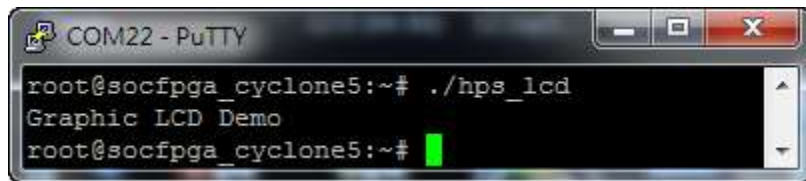

Figure 6-13 Launch LCD Demonstration

- Users should see the LCD displayed as shown in **Figure 6-14**.



Figure 6-14 LCD display for the LCD Demonstration

6.6 Setup USB Wi-Fi Dongle

This section describes how to setup the Wi-Fi USB dongle under Linux, so Linux user can wirelessly connect to the Wi-Fi AP (Access Point) through the Wi-Fi USB Dongle and finally connect to the internet. The Wi-Fi AP is assumed to have the DHCP server capability and is connected to the internet. You should also make sure you know the SSID and Password of the Wi-Fi AP.

■ System Diagram

Figure 6-15 shows the block diagram of this demonstration. The Wi-Fi AP assumes you have the DHCP server capability and is connected to the LAN (Local Area Network) or the internet. The USB Wi-Fi Dongle connects to the Wi-Fi AP and gets an address IP from the Wi-Fi AP. Through the Wi-Fi AP, the USB-Dongle will be able to communicate with the devices connected to the LAN or the internet.

```
ctrl_interface=/var/run/wpa_supplicant

network={
    ssid="Your_SSID"
    psk="Your_WPA-Key_ASCII"
}
```

- In the configuration file, replace "Your_SSID" and "Your_WPA-Key_ASCII" with the SSID and password for your Wi-Fi AP, in respectively.

```
ctrl_interface=/var/run/wpa_supplicant

network={
    ssid="Terasic"
    psk="1234567890"
}
```

- Type "ifup wlan0" in the UART terminal to connect to the Wi-Fi AP.

```
root@DE10-Standard:~# ifup wlan0
Internet Systems Consortium DHCP Client 4.3.3
Copyright 2004-2015 Internet Systems Consortium.
All rights reserved.
For info, please visit https://www.isc.org/software/dhcp/

Listening on LPF/wlan0/f0:b4:29:3c:eb:7a
Sending on LPF/wlan0/f0:b4:29:3c:eb:7a
Sending on Socket/fallback
DHCPDISCOVER on wlan0 to 255.255.255.255 port 67 interval 3 (xid=0x34840b19)
DHCPDISCOVER on wlan0 to 255.255.255.255 port 67 interval 8 (xid=0x34840b19)
DHCPREQUEST of 192.168.2.2 on wlan0 to 255.255.255.255 port 67 (xid=0x190b8434)
DHCPOFFER of 192.168.2.2 from 192.168.2.1
DHCPACK of 192.168.2.2 from 192.168.2.1
bound to 192.168.2.2 -- renewal in 38446 seconds.
```

- Type "ifconfig wlan0" in the UART terminal to confirm an IP Address is assigned to wlan0 interface.

```
root@DE10-Standard:~# ifconfig wlan0
wlan0    Link encap:Ethernet  HWaddr f0:b4:29:3c:eb:7a
         inet addr:192.168.2.2  Bcast:192.168.2.255  Mask:255.255.255.0
         inet6 addr: fe80::f2b4:29ff:fe3c:eb7a/64 Scope:Link
         UP BROADCAST RUNNING MULTICAST  MTU:1500  Metric:1
         RX packets:9 errors:0 dropped:0 overruns:0 frame:0
         TX packets:14 errors:0 dropped:0 overruns:0 carrier:0
         collisions:0 txqueuelen:1000
         RX bytes:2086 (2.0 KB)  TX bytes:2188 (2.1 KB)
```

- Make sure Wi-Fi AP is connected to the internet. Type "ping -c 4 www.terasic.com" in the UART terminal to check internet connection status. If 0% packet loss is reported, it means the connection is good.

```
root@DE10-Standard:~# ping -c 4 www.terasic.com
PING www.terasic.com (192.254.233.22) 56(84) bytes of data:
64 bytes from www.terasic.com (192.254.233.22): icmp_seq=1 ttl=50 time=180 ms
64 bytes from www.terasic.com (192.254.233.22): icmp_seq=2 ttl=50 time=203 ms
64 bytes from www.terasic.com (192.254.233.22): icmp_seq=3 ttl=50 time=160 ms
64 bytes from www.terasic.com (192.254.233.22): icmp_seq=4 ttl=50 time=205 ms

--- www.terasic.com ping statistics ---
4 packets transmitted, 4 received, 0% packet loss, time 3004ms
rtt min/avg/max/mdev = 160.602/187.540/205.380/18.345 ms
```

6.7 Query Internet Time

This demonstration shows how clients use timing web server and query the internet time through Internet. The time information will be shown on the UART terminal with the format HH:MM:SS. The DE10-Standard connects to Ethernet through wire RJ45 Port or wireless Wi-Fi USB-Dongle. For details about how to setup the Wi-Fi USB-Dongle, please refer to the chapter **6.6 Setup USB Wi-Fi Dongle**.

■ Function Block Diagram

Figure 6-16 shows the function block diagram of the Query Internet Time. A free third-party library **libcurl** is to handle URL transfer tasks. The main program uses "http get" request to query web content and directly display the response content on the NIOS II terminal.

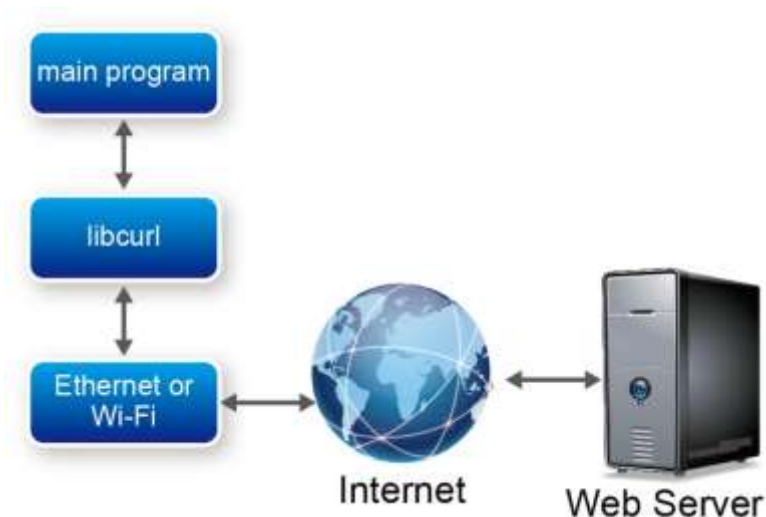

Figure 6-16 Function block diagram of Internet Time demonstration

■ URL transfer library: libcurl

The **libcurl** library is designed for the client site of the network. The library implements complex internet protocol but provides simple C API for developers. The developers for client program can easily communicate to the server by calling the API exported in the library.

For details, please refer to <https://curl.haxx.se/libcurl/>

■ How to Query Internet Time

The internet time information is available at <http://demo.terasic.com>. Sending URL <http://demo.terasic.com/time/> to the web server, it will respond with current time in the following format HH:MM:SS.

■ Demonstration Source Code

- Build tool: SoC EDS V16.1
- Project directory: \Demonstration\SoC_Advanced\NET_Time
- Binary file: NET_Time
- Build command: make ('make clean' to remove all temporal files)
- Execute command: ./NET_Time

■ Demonstration Setup

- Connect a speaker to the Line-out audio jack () on the DE10-Standard board.
- Connect a USB cable to the USB-to-UART connector (J4) on the DE10-Standard board and the host PC.
- Copy the executable file "NET_Time" into the microSD card under the "/home/root" folder in Linux.
- Insert the LXDE booting microSD card into the DE10_Standard board.
- Power on the DE10-Standard board.
- Launch PuTTY to establish the connection between the UART port of DE10-Standard board and the host PC. Type "root" and then press "Enter." By pressing "Enter," you can login to LXDE Linux without the need to enter the password.
- Type "./NET_Time" in the UART terminal of PuTTY to start the program.

```
root@DE10-Standard:~# ./NET_Time  
03:25:26
```

- The UTC(Universal Time Coordinated) time will be display on the UART terminal. Press "CTRL + C" to terminate the application.

6.8 ALSA Audio Play

This demonstration shows how to use the ALSA Audio API to play the audio. The built-in ALSA driver is included the DE10-Standard LXDE Desktop BSP.

Note: LXDE Desktop BSP is required for this demonstration.

■ Function Block Diagram

Figure 6-17 shows the function block diagram of the ALSA Audio Play demonstration. The ALSA driver uses Linux I2C driver to configure the Audio Chip and sends audio data to Audio Controller in FPGA side. The audio controller will send the received audio data to the Audio Chip through the I2S interface subsequently for the audio chip to drive the speaker through the line-out audio jack.

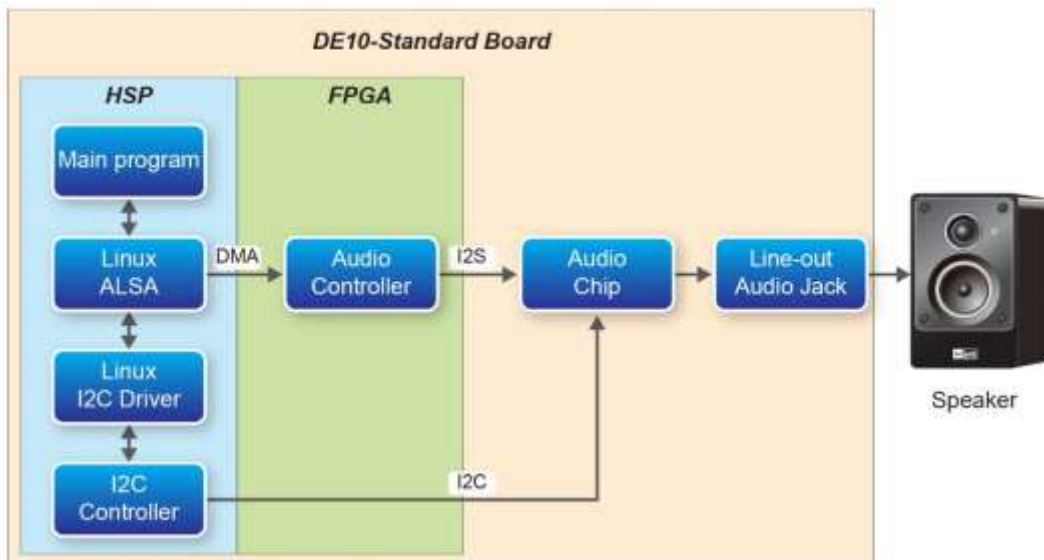

Figure 6-17 Function block diagram of ALSA Audio Player demonstration

■ Play Audio

In the c code project, the **Play** function is implemented to play a specified frequency tone in a given duration. The main program will call the **Play** function to generate various audio frequencies. The function prototype is defined as:

```
bool Play(float fToneFreq, int ms_dur);
```

Described below is the major procedure in the **Play** function:

- Open a stream playback PCM device
- Set PCM device sample rate as 44100
- Set PCM device channel as 2 channels
- Allocate a memory buffer to store PCM signals
- Generate PCM signals and same then in the buffer
- Play PCM signals
- Free memory.
- Close PCM device.

■ ALSA Library and Header File for HPS ARM

The ALSA library and header file is located in the **alsa** folder under this demonstration folder. The include path parameter “-I./alsa/include” is added to the **Makefile** so the compiler can find the associated header file. The library include parameter “-L./alsa/library -lasound” is added to the **Makefile**, so the linker can find the associated library and link it. **Figure 6-18** shows the content of the **Makefile**.

```

TARGET = alsa_play

ALT_DEVICE_FAMILY ?= soc_cv_av
SOCEDS_ROOT ?= $(SOCEDS_DEST_ROOT)
HWLIBS_ROOT = $(SOCEDS_ROOT)/ip/altera/hps/altera_hps/hwlib
CROSS_COMPILE = arm-linux-gnueabi-
CFLAGS = -g -Wall -std=c++11 -D$(ALT_DEVICE_FAMILY) -I./alsa/include
LDFLAGS = -g -Wall -lstdc++ -L./alsa/library -lasound
#CC = $(CROSS_COMPILE)gcc
CC = $(CROSS_COMPILE)g++
ARCH= arm

build: $(TARGET)

$(TARGET): main.o
$(CC) $(LDFLAGS) $^ -o $@

%.o : %.c
$(CC) $(CFLAGS) -c $< -o $@

.PHONY: clean
clean:
rm -f $(TARGET) *.a *.o *~

```

Figure 6-18 Makefile content of audio play demo

■ Demonstration Source Code

- Build tool: SoC EDS V16.1
- Project directory: \Demonstration\SoC_Advanced\alsa_play
- Binary file: alsa_play
- Build command: make ('make clean' to remove all temporal files)
- Execute command: ./alsa_play
- ALSA Library and Header File: \Demonstration\SoC_Advanced\alsa_play\alsa

■ Demonstration Setup

- Connect a speaker to the Line-out audio jack (J3) on the DE10-Standard board.
- Connect a USB cable to the USB-to-UART connector (J4) on the DE10-Standard board and the host PC.
- Copy the executable file "**alsa_play**" into the microSD card under the **"/home/root"** folder in Linux. (DE10-Standard LXDE has pre-installed this code, so users can skip this copy action.)
- Insert the **LXDE** booting micro SD card into the DE10-Standard board.
- Power on the DE10-Standard board.
- Launch PuTTY to establish the connection between the UART port of DE10-Standard board and the host PC.
- In the PuTTY UART terminal, type "root" to login LXDE Linux.
- Type **"./alsa_play "** in the UART terminal to start the program.
- You will hear audio sound from the speaker attached to DE10-Standard board.

Chapter 7

Examples for using both HPS SoC and FGPA

This Chapter demonstrates how to use the HPS/ARM to communicate with FPGA. We will introduce the GHRD project for DE10-Standard development board. And we develop one ARM C Project which demonstrates how HPS/ARM program controls the ten LEDs connected to FPGA. We will show how HPS controls the FPGA LED through Lightweight HPS-to-FPGA Bridge. The FPGA is configured by HPS through FPGA manager in HPS.

7.1 Required Background

This section pre-assumed the developers have the following background knowledge:

■ FPGA RTL Design

- Basic Quartus Prime operation skill
- Basic RTL coding skill
- Basic Qsys operation skill
- Knowledge about Memory-Mapped Interface

■ C Program Design

- Basic SoC EDS(Embedded Design Suite) operation skill
- Basic C coding and compiling skill
- Skill to Create a Linux Boot SD-Card for DE10-Standard with a given image file
- Skill to boot Linux from SD-Card on DE10-Standard Skill to cope files into Linux file system on DE10-Standard Basic Linux command operation skill

7.2 System Requirements

Before starting this tutorial, please note that the following items are required to complete the demonstration project:

■ Terasic DE10-Standard FPGA board, includes

- Mini USB Cable for UART terminal
- Micros SD-Card, at 4GB minimum
- Micros SD-Card Card Reader

■ A x86 PC

- Windows 7 64 bit operation system Installed
- One USB Port
- Quartus Prime 16.1 or Later Installed
- SoC EDS 16.1 or Later Installed
- Win32 Disk Imager Installed

7.3 AXI bridges in Intel SoC FPGA

In Intel SoC FPGA, the HPS logic and FPGA fabric are connected through the AXI (Advanced eXtensible Interface) bridge. For HPS logic to communicate with FPGA fabric, Intel system integration tool **Qsys** should be used for the system design to add **HPS** component. From the AXI master port of the HPS component, HPS can access those Qsys components whose memory-mapped slave ports are connected to the master port.

The HPS contains the following HPS-FPGA AXI bridges.

- FPGA-to-HPS Bridge
- HPS-to-FPGA Bridge
- Lightweight HPS-to-FPGA Bridge



Figure 7-1 shows a block diagram of the AXI bridges in the context of the FPGA fabric and the L3 interconnect to the HPS. Each master (M) and slave (S) interface is shown with its data width(s). The clock domain for each interconnect is noted in parentheses.

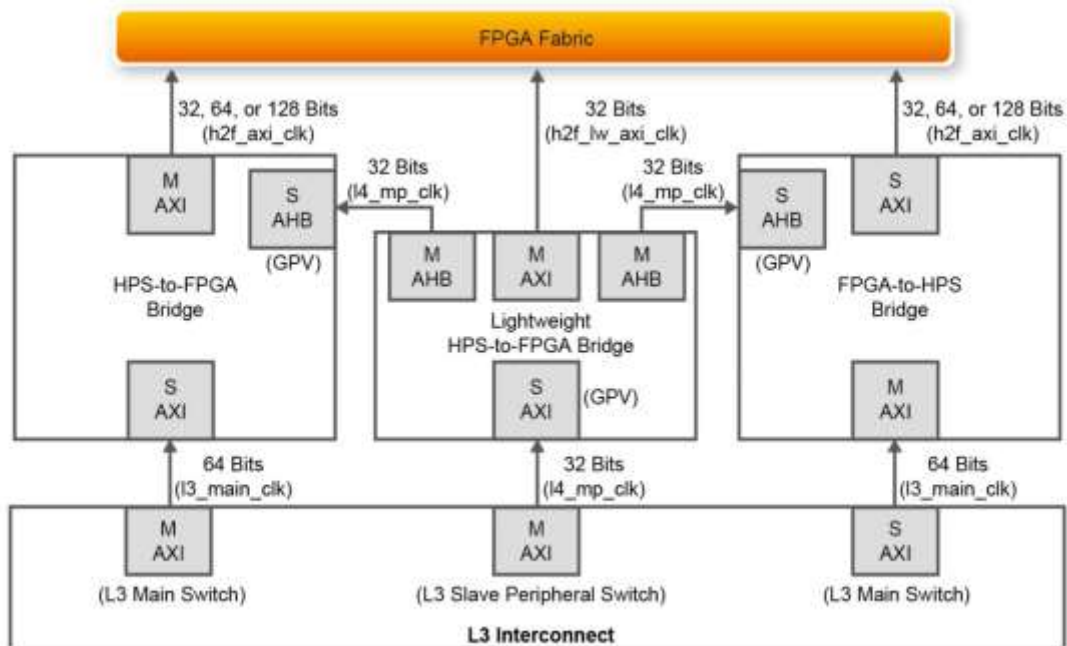

Figure 7-1 AXI Bridge Block Diagram

The HPS-to-FPGA bridge is mastered by the level 3 (L3) main switch and the lightweight HPS-to-FPGA bridge is mastered by the L3 slave peripheral switch.

The FPGA-to-HPS bridge masters the L3 main switch, allowing any master implemented in the FPGA fabric to access most slaves in the HPS. For example, the FPGA-to-HPS bridge can access the accelerator coherency.

All three bridges contain global programmer view GPV register. The GPV register control the behavior of the bridge. It is able to access to the GPV registers of all three bridges through the lightweight HPS-to-FPGA bridge.

This Demo introduces to users how to use the HPS/ARM to communicate with FPGA. This project includes GHRD project for the DE10-Standard one ARM C Project which demonstrates how HPS/ARM program controls the red LEDs connected to FPGA.

7.4 GHRD Project

The term GHRD is short for Golden Hardware Reference Design. The GRD project provide by Terasic for the DE10-Standard development board is located in the CD folder: CD-ROM/Demonstration\SOC_FPGA\DE10_Standard_GHRD.

The project consists of the following components:

- ARM Cortex™-A9 MPCore HPS
- Four user push-button inputs
- Ten user DIP switch inputs
- Ten user I/O for LED outputs
- 64KB of on-chip memory
- JTAG to Avalon master bridges
- Interrupt capturer for use with System Console
- System ID

The memory map of system peripherals in the FPGA portion of the SoC as viewed by the MPU starts at the lightweight HPS-to-FPGA base address 0xFF20_0000. The MPU can access these peripherals through the Address offset setting in the Qsys. User can open the GHRD project with Quartus II Software. Then open the soc_system.qsys file with the Qsys tool. **Figure 7-2** lists the address map of the peripherals which are connected to the lightweight HPS-to-FPGA.

Component	mm_bridge_0.m0	fpga_only_mast...
hps_0.f2h.sdram0.data		
sysid.qsys.control_slave	0x0000_1000 - 0x0000_1007	0x0000_1000 - 0
led.pio.sl	0x0000_3000 - 0x0000_300f	0x0000_3000 - 0
dipsw.pio.sl	0x0000_4000 - 0x0000_400f	0x0000_4000 - 0
button.pio.sl	0x0000_5000 - 0x0000_500f	0x0000_5000 - 0
jtag_uart.avalon_jtag_slave	0x0002_0000 - 0x0002_0007	0x0002_0000 - 0
ILC.avalon_slave	0x0003_0000 - 0x0003_00ff	0x0003_0000 - 0
hps_0.f2h.axi_slave		
mm_bridge_0.s0		
ILC.avalon_slave via mm_bridge_0		
jtag_uart.avalon_jtag_slave vi...		
led.pio.sl via mm_bridge_0		
dipsw.pio.sl via mm_bridge_0		
sysid.qsys.control_slave via m...		
button.pio.sl via mm_bridge_0		

Figure 7-2 FPGA peripherals address map

All the Avalon Conduit signals of these peripherals are connected to the I/O pins of the SoCFPGA on DE10-Standard board as shown in the **Figure 7-3**.

```

//HPS SPI
-hps_0_hps_to_hps_to_spi0_inst_CLK ( HPS_SPI0_CLK ), //
-hps_0_hps_to_hps_to_spi0_inst_MOSI ( HPS_SPI0_MOSI ), //
-hps_0_hps_to_hps_to_spi0_inst_MISO ( HPS_SPI0_MISO ), //
-hps_0_hps_to_hps_to_spi0_inst_SS0 ( HPS_SPI0_SS ), //
//HPS UART
-hps_0_hps_to_hps_to_uart0_inst_RX ( HPS_UART_RX ), //
-hps_0_hps_to_hps_to_uart0_inst_TX ( HPS_UART_TX ), //
//HPS I2C1
-hps_0_hps_to_hps_to_i2c0_inst_SDA ( HPS_I2C0_SDA ), //
-hps_0_hps_to_hps_to_i2c0_inst_SCL ( HPS_I2C0_SCL ), //
//HPS I2C2
-hps_0_hps_to_hps_to_i2c1_inst_SDA ( HPS_I2C1_SDA ), //
-hps_0_hps_to_hps_to_i2c1_inst_SCL ( HPS_I2C1_SCL ), //
//GPIO
-hps_0_hps_to_hps_to_gpio_inst_GPIO09 ( HPS_CONV_USB_N ), //
-hps_0_hps_to_hps_to_gpio_inst_GPIO35 ( HPS_ENET_INT_N ), //
-hps_0_hps_to_hps_to_gpio_inst_GPIO40 ( HPS_LTC_GPIO ), //
-hps_0_hps_to_hps_to_gpio_inst_GPIO53 ( HPS_LED ), //
-hps_0_hps_to_hps_to_gpio_inst_GPIO54 ( HPS_KEY ), //
-hps_0_hps_to_hps_to_gpio_inst_GPIO61 ( HPS_GSENSOR_INT ), //
//CPLD PARTIAL
-led_pio_external_connection_export ( fpga_led_internal ), // led_pio_external_connection_export
-dipsw_pio_external_connection_export ( sw ), // dipsw_pio_external_connection_export
-button_pio_external_connection_export ( fpga_debounce_buttons ), // button_pio_external_connection_export
-hps_0_f2h_reset_req_reset_n ( hps_fpga_reset_n ), // hps_0_f2h_reset_req_reset_n
-hps_0_f2h_cold_reset_req_reset_n ( hps_cold_reset ), // hps_0_f2h_cold_reset_req_reset_n
-hps_0_f2h_debug_reset_req_reset_n ( hps_debug_reset ), // hps_0_f2h_debug_reset_req_reset_n
-hps_0_f2h_sta_hw_events_sta_hwevents ( sta_hw_events ), // hps_0_f2h_sta_hw_events_sta_hwevents
-hps_0_f2h_warn_reset_req_reset_n ( hps_warn_reset ), // hps_0_f2h_warn_reset_req_reset_n

```

Figure 7-3 Connection in the top design

7.5 Compile and Programming

In the Qsys tool, click the menu item “Generate→Generate...” to generate source code for the system and then close the Qsys tool. Now, users can start the compile process by clicking the menu item “Processing→Start Compilation”.

Because .tcl files of SDRAM DDR3 controller for HPS had been executed in GHRD project, developers can skip this procedure. If developers’ Quartus project is not developed based on the GHRD project, please remember to execute the .tcl files of SDRAM DDR3 controller, as show in **Figure 7-4**, before executing ‘Start Compilation’.

The TCL Scripts dialog can be launched by clicking the menu item “Tools→TCL Scripts...”. <qsys_system_name>_parameters.tcl and <qsys_system_name>_pin_assignments.tcl tcl files should be executed, where <qsys_system_name> is the name of your Qsys system. Run this script to assign constrains for the SDRAM DDR3 component.

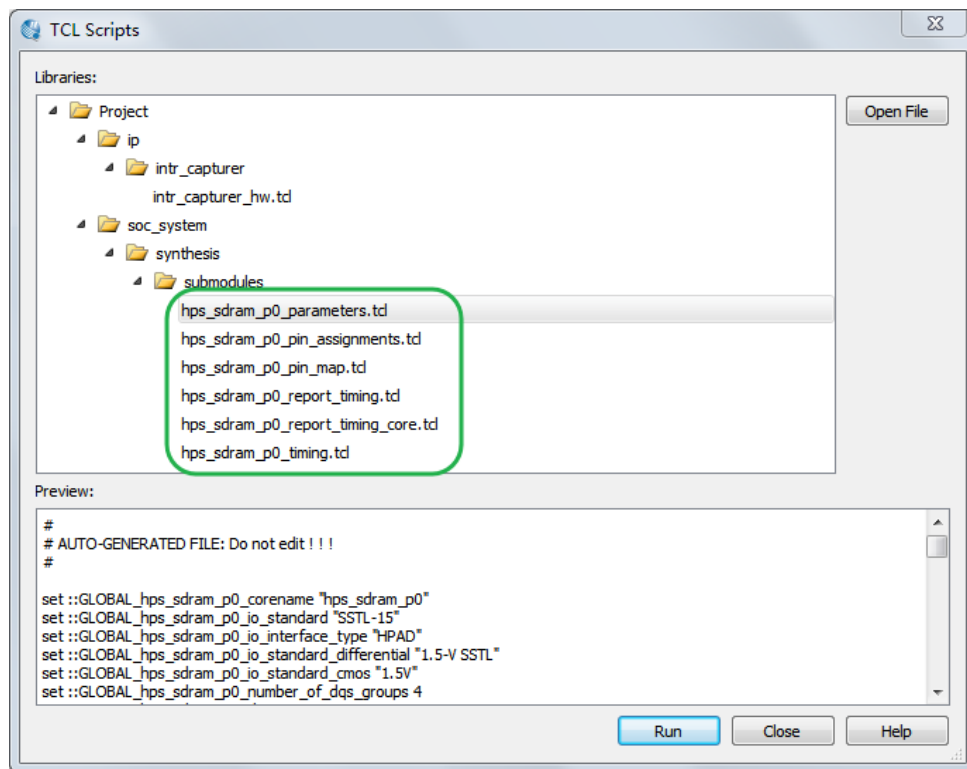

Figure 7-4 Running the SDRAM Controller tcl

Now, users can start the compile process by clicking the menu item “Processing→Start Compilation”. When the compilation process is completed successfully, **DE10_Standard_GHRD.sof** is generated in the DE10_Standard_GHRD/output_files folder. Users can use this file to configure FPGA by Quartus Programming through the DE10-Standard on-board USB-Blaster II.

7.6 Develop the C Code

This section introduces how to design an ARM C program to control the led_pio PIO controller. SoC EDS is used to compile the C project. For ARM program to control the led_pio PIO component, led_pio address is required. The Linux built-in driver '/dev/mem' and mmap system-call are used to map the physical base address of led_pio component to a virtual address which can be directly accessed by Linux application software.

■ HPS Header File

pio_led component information is required for ARM C program as the program will attempt to control the component. This section describes how to use a given Linux shell batch file to extract the Qsys HPS information to a header file which will be included in the C program later.

The batch file mentioned above is called as **generate_hps_qsys_header.sh**. It is located in the same folder as DE10_Standard_GHRD Quartus project. To generate the header file, launch SoC EDS command shell, go to the Quartus project folder, and execute **generate_hps_qsys_header.sh** by

typing './generate_hps_qys_header.sh'. Then, press ENTER key, a header file **hps_0.h** will be generated. In the header file, the **led_pio** base address is represented by a constant LED_PIO_BASE as show in **Figure 7-5**. The **led_pio** width is represented by a constant LED_PIO_DATA_WIDTH. These two constants will be used in the C program demonstration code.

```

/*
 * Macros for device 'led_pio', class 'altera_avalon_pio'
 * The macros are prefixed with 'LED_PIO_'.
 * The prefix is the slave descriptor.
 */
#define LED_PIO_COMPONENT_TYPE altera_avalon_pio
#define LED_PIO_COMPONENT_NAME led_pio
#define LED_PIO_BASE 0x3000
#define LED_PIO_SPAN 16
#define LED_PIO_END 0x300f
#define LED_PIO_BIT_CLEARING_EDGE_REGISTER 0
#define LED_PIO_BIT_MODIFYING_OUTPUT_REGISTER 0
#define LED_PIO_CAPTURE 0
#define LED_PIO_DATA_WIDTH 10
#define LED_PIO_DO_TEST_BENCH_WIRING 0
#define LED_PIO_DRIVEN_SIM_VALUE 0
#define LED_PIO_EDGE_TYPE NONE
#define LED_PIO_FREQ 50000000

```

Figure 7-5 pio_led information defined in hps_0.h

■ Map LED_PIO Address

This section will describe how to map the pio_led physical address into a virtual address which is accessible by an application software. **Figure 7-6** shows the C program to derive the virtual address of led_pio base address. First, open system-call is used to open memory device driver “/dev/mem”, and then the mmap system-call is used to map HPS physical address into a virtual address represented by the void pointer variable virtual_base. The demo code maps the physical base address (HW_REGS_BASE = 0xfc000000) of the peripheral region into a based virtual address virtual_base. For any controller in the peripheral region, users can calculate their virtual address by adding their offset relative to the peripheral region to the based virtual address virtual_base. Based on the rule, the virtual address of led_pio can be calculated by adding the below two offset addresses to virtual_base.

- Offset address of Lightweight HPS-to-FPGA AXI bus relative to HPS base address
- Offset address of Pio_led relative to Lightweight HPS-to-FPGA AXI bus

The first offset address is 0xff200000 which is defined as a constant ALT_LWFPGASLVS_OFST in the header hps.h. The hps.h is a header of SoC EDS. It is located in the Quartus installation folder: D:\altera\embedded\ip\altera\hps\altera_hps\hwlib\include\soc_cv_av\socal.

The second offset address is 0x3000 which is defined as LED_PIO_BASE in the hps_0.h header

file which is generated in above section.

The virtual address of `pio_led` is represented by a void pointer variable `h2p_lw_led_addr`. Application program can directly use the pointer variable to access the registers in the controller of **LED_PIO**.

```
#define HW_REGS_BASE ( ALT_STM_OFST )
#define HW_REGS_SPAN ( 0x04000000 )
#define HW_REGS_MASK ( HW_REGS_SPAN - 1 )

int main() {

    void *virtual_base;
    int fd;
    int loop_count;
    int led_direction;
    int led_mask;
    void *h2p_lw_led_addr;

    // map the address space for the LED registers into user space so we can interact with them.
    // we'll actually map in the entire CSR span of the HPS since we want to access various
    // registers within that span

    if( ( fd = open( "/dev/mem", ( O_RDWR | O_SYNC ) ) ) == -1 ) {
        printf( "ERROR: could not open \"/dev/mem\"...\n" );
        return( 1 );
    }

    virtual_base = mmap( NULL, HW_REGS_SPAN, ( PROT_READ | PROT_WRITE ), MAP_SHARED, fd, HW_REGS_BASE );

    if( virtual_base == MAP_FAILED ) {
        printf( "ERROR: mmap() failed...\n" );
        close( fd );
        return( 1 );
    }

    h2p_lw_led_addr = (unsigned long) virtual_base
        ((unsigned long) (ALT_LWFGASLVS_OFST + LED_PIO_BASE) & (unsigned long) (HW_REGS_MASK));
}
```

Figure 7-6 LED_PIO memory map code

■ LED Control

C programmers need to understand the Register Map of the PIO core for **LED_PIO** before they can control it. **Figure 7-7** shows the Register Map for the PIO Core. Each register is 32-bit width. For detail information, please refer to the datasheet of PIO Core. For led control, we just need to write output value to the offset 0 register relative to based address 0x10040. Because the led on DE10-Standard is high active, writing a value 0x00000000 to the offset 0 register will turn off all of the nine red LEDs. There are 10 red LEDs on DE10-Standard and 9 of them are connected to this controller. The last LED (LED0) is used to implement FPGA heartbeat. Writing a value 0x000001ff to the offset 0 register will turn on all of nine red LEDs. In C program, writing a value 0x000001ff to the offset 0 register of `pio_led` can be implemented as:

```
*(uint32_t *) h2p_lw_led_addr= 0x000001ff;
```

The state will assign the void pointer to a `uint32_t` pointer, so C compiler knows write a 32-bit value 0x000001ff to the virtual address `h2p_lw_led_addr`.

Offset	Register Name		R/W	Fields				
				(n-1)	...	2	1	0
0	data	read access	R	Data value currently on PIO inputs.				
		write access	W	New value to drive on PIO outputs.				
1	direction (1)		R/W	Individual direction control for each I/O port. A value of 0 sets the direction to input; 1 sets the direction to output.				
2	interruptmask (1)		R/W	IRQ enable/disable for each input port. Setting a bit to 1 enables interrupts for the corresponding port.				
3	edgecapture (1), (2)		R/W	Edge detection for each input port.				
4	outset		W	Specifies which bit of the output port to set.				
5	outclear		W	Specifies which output bit to clear.				

Figure 7-7 Register Map of PIO Core

■ Main Program

In the main program, the LED is controlled to perform LED light shifting operation as shown in Figure 7-8. When finishing 60 times of shift cycle, the program will be terminated.

```

loop_count = 0;
led_mask = 0x01;
led_direction = 0; // 0: left to right direction
while( loop_count < 60 ) {

    // control led, add ~ because the led is low-active
    *(uint32_t *)h2p_1w_led_addr = ~led_mask;

    // wait 100ms
    usleep( 100*1000 );

    // update led mask
    if (led_direction == 0){
        led_mask <<= 1;
        if (led_mask == (0x01 << (PIO_LED_DATA_WIDTH-1))){
            led_direction = 1;
        }
    }else{
        led_mask >>= 1;
        if (led_mask == 0x01){
            led_direction = 0;
            loop_count++;
        }
    }
}
} // while

```

Figure 7-8 C Program for LED Shift Operation

■ Makefile and compile

Figure 7-9 shows the content of Makefile for this C project. The program includes the head files provided by SoC EDS. In the Makefile, ARM-linux cross-compile also be specified.

```

#
TARGET = HPS_FPGA_LED

#
ALT_DEVICE_FAMILY ?= soc_cv_av
SOCEDS_ROOT ?= $(SOCEDS_DEST_ROOT)
HMLIBS_ROOT = $(SOCEDS_ROOT)/ip/altera/hps/altera_hps/hwlib
CROSS_COMPILE = arm-linux-gnueabihf-
CFLAGS = -g -Wall -D$(ALT_DEVICE_FAMILY) -I$(HMLIBS_ROOT)/include/$(ALT_DEVICE_FAMILY) -I$(HMLIBS_ROOT)/include/
LDFLAGS = -g -Wall
CC = $(CROSS_COMPILE)gcc
ARCH= arm

build: $(TARGET)
$(TARGET): main.o
    $(CC) $(LDFLAGS) $@ -o $@
%.o : %.c
    $(CC) $(CFLAGS) -c $< -o $@

.PHONY: clean
clean:
    rm -f $(TARGET) *.a *.o *~

```

Figure 7-9 Makefile content

To compile the project, type “make” in the command shell as shown in **Figure 7-10**. Then, type “ls” to check the generated ARM execution file “HPS_FPGA_LED”.

```

matthew@matthew-PC /cygdrive/e/SVN/DE10_Standard/demonstration/SoC_FPGA/HPS_FPGA_LED
$ ls
hps_0.h main.c Makefile

matthew@matthew-PC /cygdrive/e/SVN/DE10_Standard/demonstration/SoC_FPGA/HPS_FPGA_LED
$ make
arm-linux-gnueabihf-gcc -g -Wall -Dsoc_cv_av -ID:/altera/16.0/embedded/ip/altera/hps/altera_hps/hwlib/include/soc_cv_av -ID:/altera/16.0/embedded/ip/altera/hps/altera_hps/hwlib/include/ -c main.c -o main.o
arm-linux-gnueabihf-gcc -g -Wall main.o -o HPS_FPGA_LED

matthew@matthew-PC /cygdrive/e/SVN/DE10_Standard/demonstration/SoC_FPGA/HPS_FPGA_LED
$ ls
hps_0.h HPS_FPGA_LED main.c main.o Makefile

matthew@matthew-PC /cygdrive/e/SVN/DE10_Standard/demonstration/SoC_FPGA/HPS_FPGA_LED
$

```

Figure 7-10 ARM C Project Compilation

■ Execute the Demo

To execute the demo, please boot the Linux from the SD-card in DE10-Standard. Copy the execution file “HPS_FPGA_LED” to the Linux directory, and type “chmod +x HPS_FPGA_LED”

to add execution attribute to the execute file. Use Quartus Programmer to configure FPGA with the DE10_Standard_GHRD.sof generated in previous chapter. The LED0 will flash as the heart beat of the FPGA. Then, type “./HPS_FPGA_LED” to launch the ARM program. The LED[9..1] on DE10-Standard will be expected to perform 60 times of LED light shift operation, and then the program is terminated.

For details about booting the Linux from SD-card, please refer to the document:

Getting_Started_Guide.pdf

For details about copying files to Linux directory, please refer to the document:

My_First_HPS.pdf



Chapter 8

Programming the EPCS Device

This chapter describes how to program the quad serial configuration (EPCS) device with Serial Flash Loader (SFL) function via the JTAG interface. Users can program EPCS devices with a JTAG indirect configuration (.jic) file, which is converted from a user-specified SRAM object file (.sof) in Quartus. The .sof file is generated after the project compilation is successful. The steps of converting .sof to .jic in Quartus II are listed below.

8.1 Before Programming Begins

The FPGA should be set to AS x1 mode i.e. MSEL[4..0] = “10010” to use the quad Flash as a FPGA configuration device.

8.2 Convert .SOF File to .JIC File

1. Choose **Convert Programming Files** from the File menu of Quartus II, as shown in **Figure 8-1**.

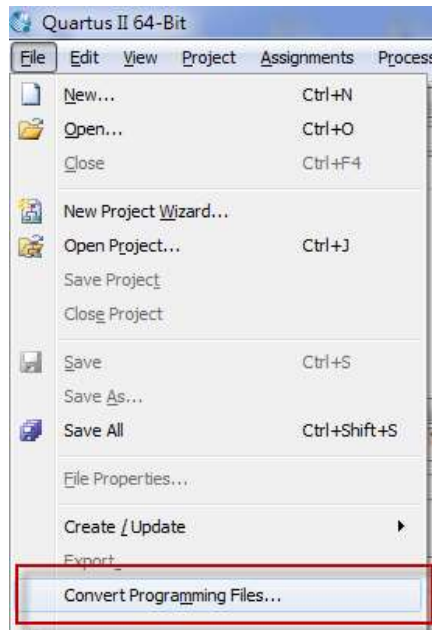

Figure 8-1 File menu of Quartus II

2. Select **JTAG Indirect Configuration File (.jic)** from the **Programming file type** field in the dialog of Convert Programming Files.
3. Choose **EPCS128** from the **Configuration device** field.
4. Choose **Active Serial** from the **Mode** field.
5. Browse to the target directory from the **File name** field and specify the name of output file.
6. Click on the **SOF data** in the section of **Input files to convert**, as shown in **Figure 8-2**.

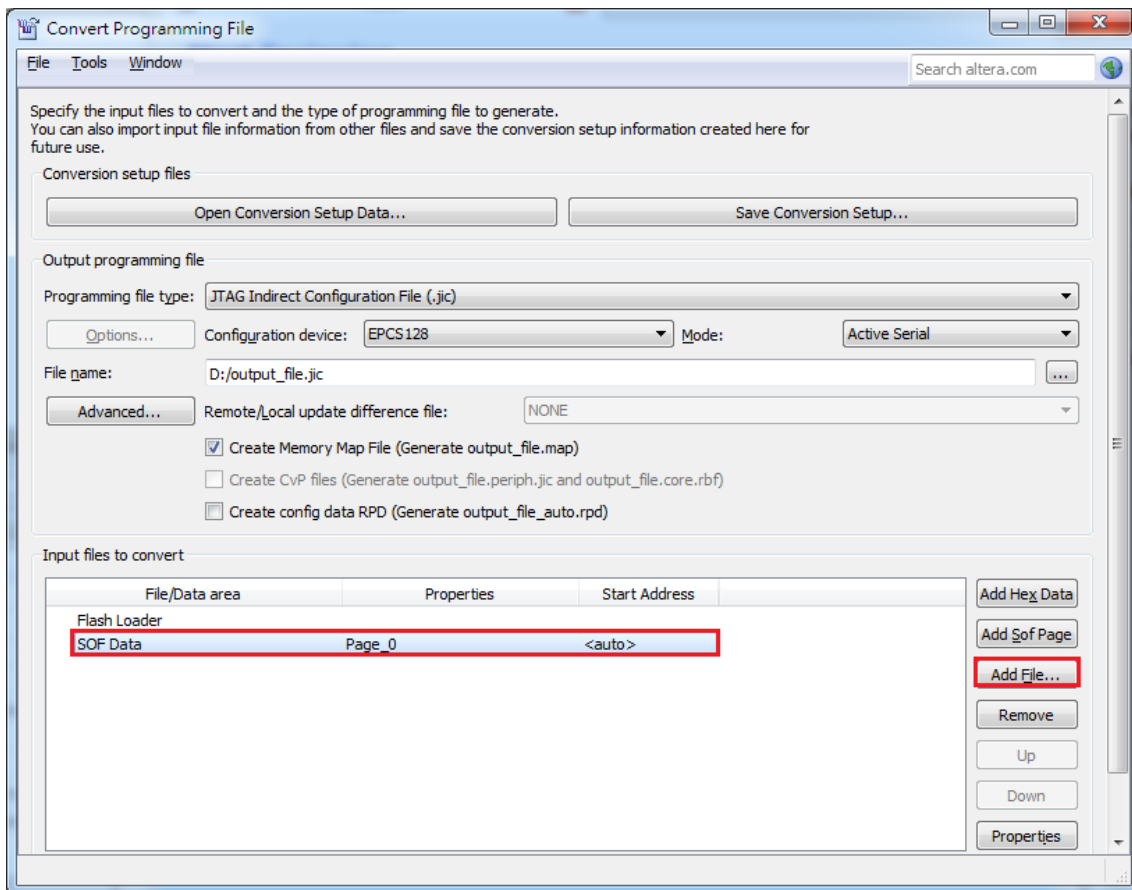

Figure 8-2 Dialog of “Convert Programming Files”

7. Click **Add File**.
8. Select the .sof to be converted to a .jic file from the Open File dialog.
9. Click **Open**.
10. Click on the **Flash Loader** and click **Add Device**, as shown in **Figure 8-3**.
11. Click **OK** and the **Select Devices** page will appear.

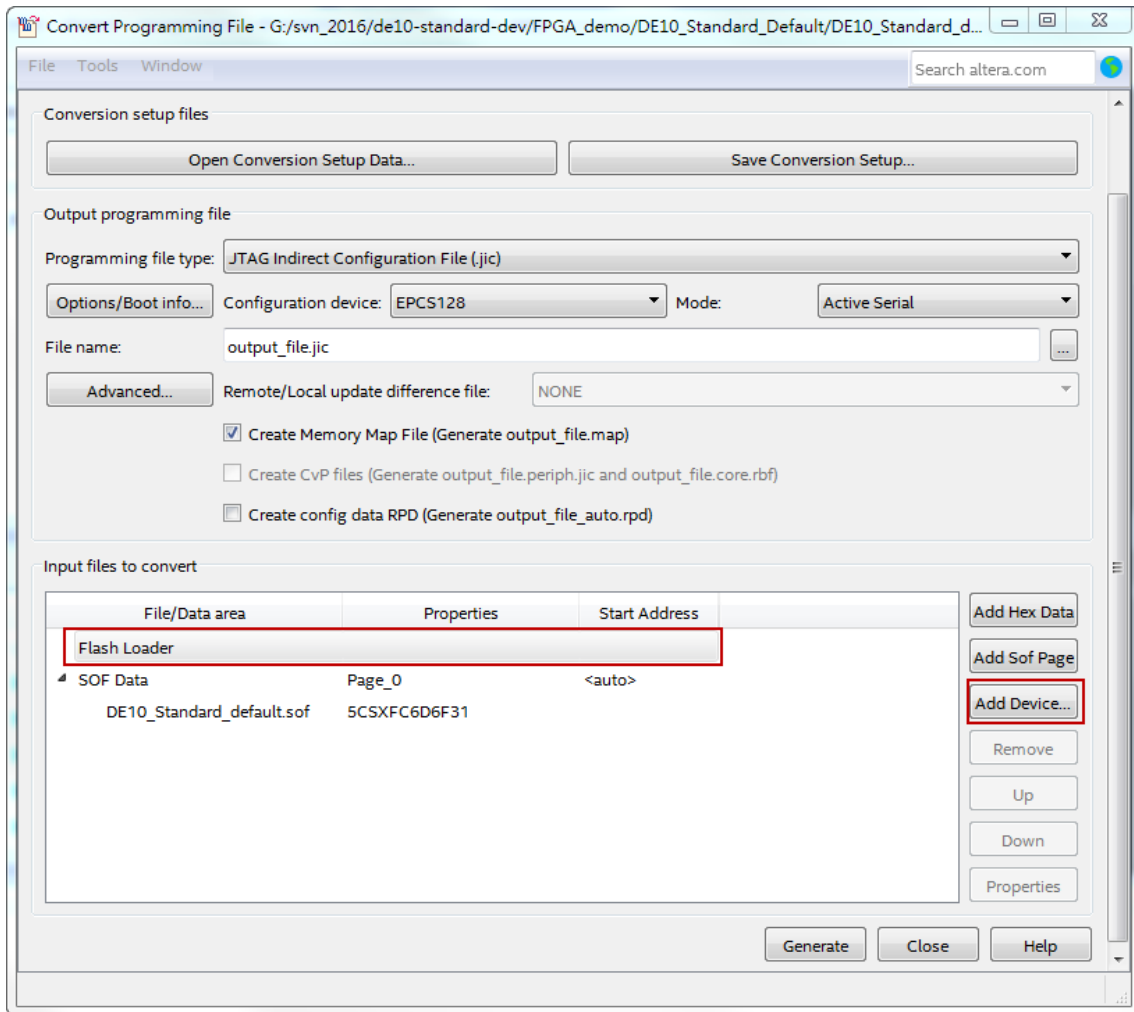

Figure 8-3 Click on the “Flash Loader”

12. Select the targeted FPGA to be programmed into the EPCS, as shown in [Figure 8-4](#).
13. Click **OK** and the **Convert Programming Files** page will appear, as shown in [Figure 8-5](#).
14. Click **Generate**.

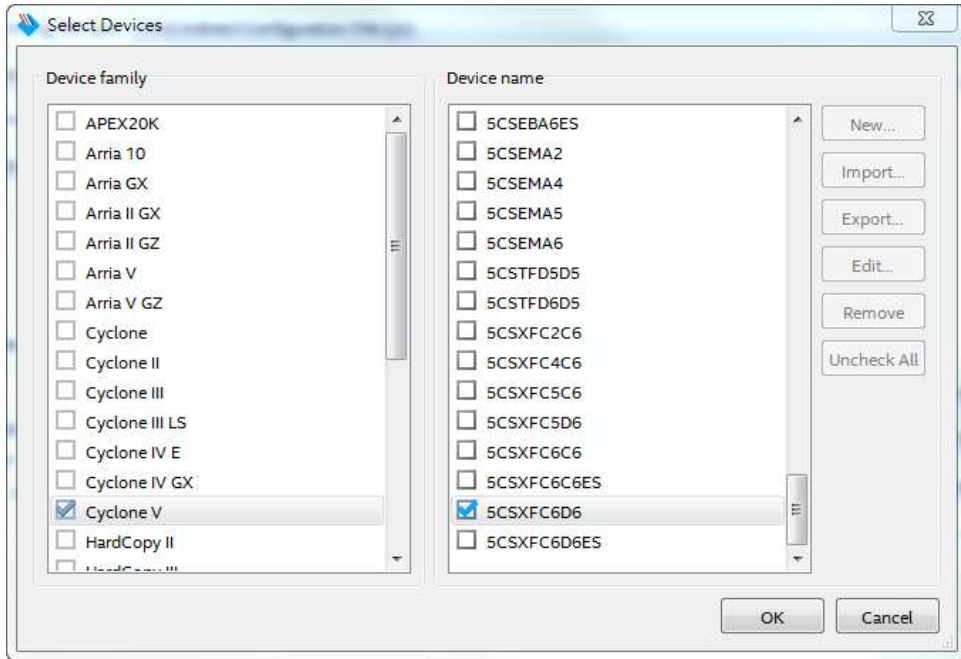

Figure 8-4 “Select Devices” page

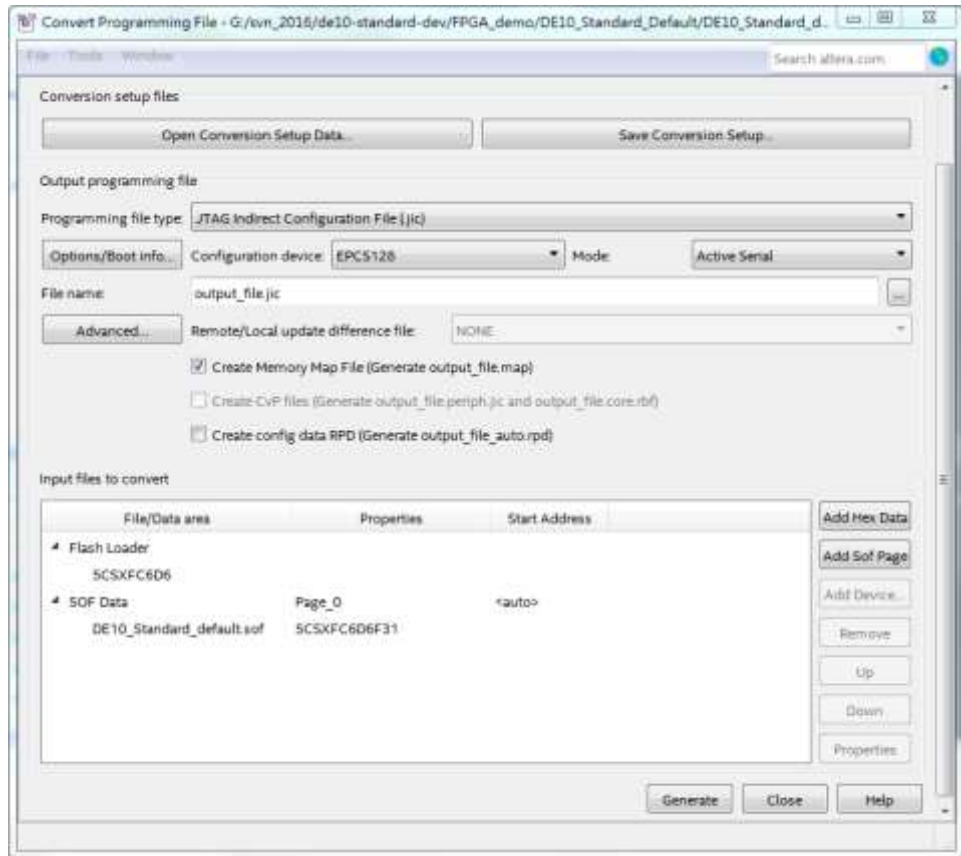

Figure 8-5 “Convert Programming Files” page after selecting the device

8.3 Write JIC File into the EPCS Device

When the conversion of SOF-to-JIC file is complete, please follow the steps below to program the EPCS device with the .jic file created in Quartus II Programmer.

1. Set MSEL[4..0] = “10010”
2. Choose **Programmer** from the Tools menu and the **Chain.cdf** window will appear.
3. Click **Auto Detect** and then select the correct device. Both FPGA device and HPS should be detected, as shown in **Figure 8-6**.
4. Double click the green rectangle region shown in **Figure 8-6** and the **Select New Programming File** page will appear. Select the .jic file to be programmed.
5. Program the EPCS device by clicking the corresponding **Program/Configure** box. A factory default SFL image will be loaded, as shown in **Figure 8-7**.
6. Click **Start** to program the EPCS device.

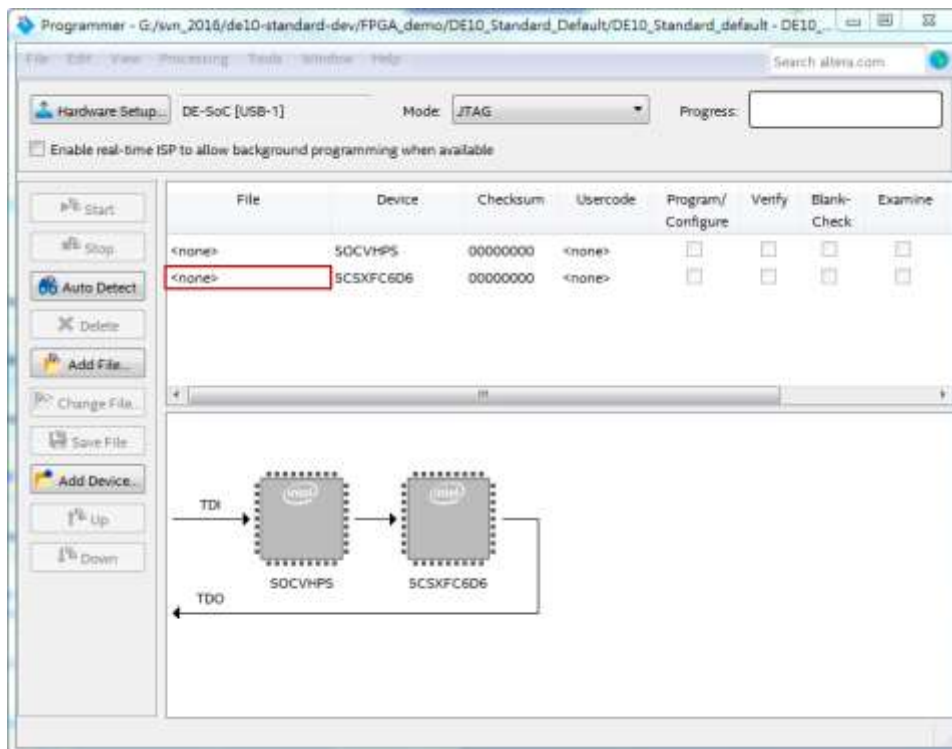

Figure 8-6 Two devices are detected in the Quartus II Programmer

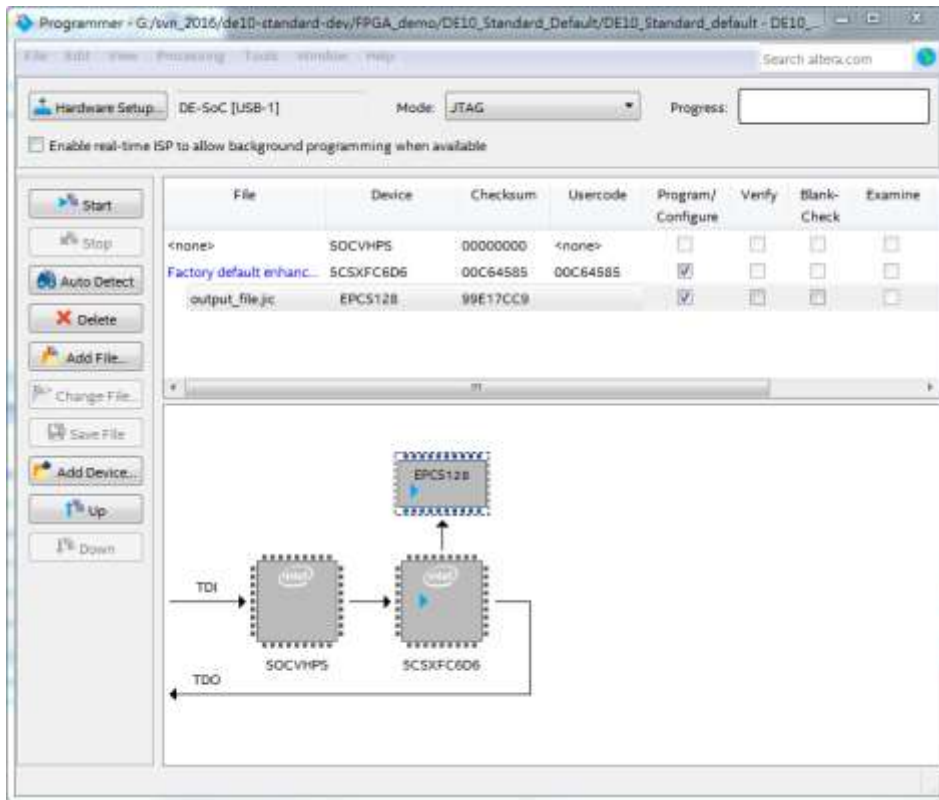

Figure 8-7 Quartus II programmer window with one .jic file

8.4 Erase the EPCS Device

The steps to erase the existing file in the EPCS device are:

1. Set MSEL[4..0] = "10010"
2. Choose **Programmer** from the **Tools** menu and the **Chain.cdf** window will appear.
3. Click **Auto Detect**, and then select correct device, both FPGA device and HPS will be detected. (See **Figure 8-6**)
4. Double click the green rectangle region shown in **Figure 8-6**, and the **Select New Programming File** page will appear. Select the correct .jic file.
5. Erase the EPCS device by clicking the corresponding **Erase** box. A factory default SFL image will be loaded, as shown in **Figure 8-8**.

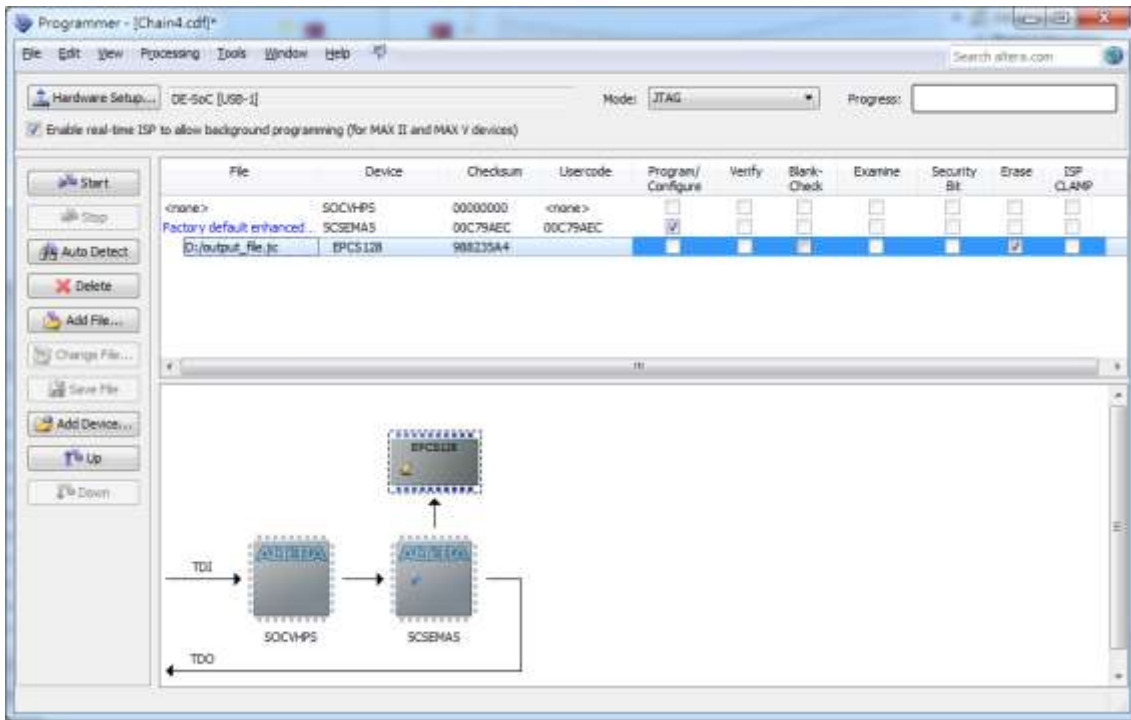

Figure 8-8 Erase the EPCS device in Quartus II Programmer

6. Click **Start** to erase the EPCS device.

Chapter 9

Linux BSP

The DE10-Standard Kit includes Linux BSP (Board Support Package) with which users can develop their software application on the Linux. The Kit contains the three Linux BSP listed below. Users can select the proper BSP for their applications.

- Linux Console BSP
- Linux LXDE Desktop BSP
- OpenCL BSP

Please be aware that not all Bluetooth/WiFi/Camera USB dongles are compatible with this BSP. Here are some compatible USB dongles that have been tested, by us, and proven to work. The following suggested Bluetooth & WiFi USB dongles can be purchased from the Terasic Website.

- Bluetooth USB Dongle
 - Esens D704 (Terasic PN: FXX-3041-ESS)
- WiFi USB Dongle
 - Mi WiFi (Terasic PN: FXX-3061-MIX)
- Camera USB Dongle
 - Logitech C310
 - ET USB 2760 Camera
 - Genius WideCam F100

These Linux BSP can be downloaded for free from the Terasic Website:

<http://de10-standard.terasic.com/cd>

9.1 Use Linux BSP

This section describes the procedure to boot Linux on DE10-Standard Board. For more details, refer to chapter 5 of *DE10-Standard_Getting_Started_Guide.pdf* in the System CD.

- Download the BSP image file from <http://de10-standard.terasic.com/cd>
- Create a Linux booting microSD card by using Win32 Disk Imager utility to write the image file into a microSD card
- Insert the microSD to microSD socket on the DE10-Standard
- Make sure MSEL[4:0] switch on DE10-Standard is set to proper position
- For console mode:



- Connect your host PC to UART-to-UBB port(J4) on DE10-standard via a USB cable
- Launch the PuTTY software in your PC
- The booting message will appear on the PuTTY terminal
- For Desktop mode:
- Connect a VGA monitor, an USB keyboard, and a USB mouse to the DE10-Standard
- Power on DE10-Standard
- The LXDE Desktop will appear on the VGA monitor

9.2 Linux Console BSP

This is a console mode Linux BSP. The console content is displayed on the UART Terminal in your Host PC. Refer to **Table 9-1** for Linux Console BSP information.

Table 9-1 Linux Console BSP Information

Item	Description
BSP Location	DE10-Standard_Linux_Console.zip Download link: http://de10-standard.terasic.com/cd
microSD Card	4GB at minimal
MSEL[4:0]	Ignore
Account	User name: root, password is not required
UART Terminal	Baud rate: 115200, Data bits: 8 Parity: None Stop Bits: 1 Flow Control: no
Quartus Project	None
BSP Feature	USB Bluetooth Dongle driver USB WiFi Dongle driver Example Codes
Linux Kernel Source	Source: https://github.com/terasic/linux-socfpga Branch: socfpga-4.5 Under above location: Configure File: de10_standard_console.config DTS File: arch/arm/boot/dts/socfpga_cyclone5_de10_standard.dts

This Linux BSP does not configure FPGA when system boots. However, users are still able to configure the FPGA in the Linux System after the system is boot completed. To configure the FPGA, two files are required. They are the FPGA device tree overlay (fpga.dtb) and the FPGA configuration bitstream (soc_sysmem.rbf). The two files should be placed in the /lib/firmware directory in the Linux file system. The below statement will describes how to generate and use

these two files.

■ Generate FPGA Configure Files: `fpga.dtbo` and `soc_system.rbf`

The `fpga.dtbo` file is generated by the `fpga.dts` file in the `Demonstration/SoC_FPGA / DE10_Standard_GHRD`. The main content in the file is copied from `soc_system.dts`. In the content, the interrupt-parent name is changed to “`intc`” and the statement `firmware-name = "soc_system.rbf"` specifies the name of the FPGA configuration bitstream. The following command is used to generate the `fpga.dtbo` in the SoC EDS command shell.

```
dtc -O dtb -o fpga.dtbo -b 0 -@ fpga.dts
```

The `soc_system.rbf` is generated with the `sof_to_rbf.bat` in the `Demonstration/SoC_FPGA/ DE10_Standard_GHRD/output_files`. Double click the `.bat` file and the `soc_system.rbf` will be generated with the `DE10_Standard_GHRD.sof`.

■ Apply FPGA Configure Files: `fpga.dtbo` and `soc_system.rbf`

After generating the two FPGA figure files, users can follow the below procedure to configure the FPGA by using these two configure files.

- Download the Linux Console image from <http://de10-standard.terasic.com/cd> and unzip the file to `de10_standard_linux_console.img`.
- Refer to `DE10-Standard_Getting_Started_Guide.pdf` for writing the Image to the MicroSD card and setup the Putty Terminal.
- For configuration of the FPGA, the `MSEL[4..0]` should be set to `01010` before powering up the `DE10_Standard` board.
- Login to the linux console with `root` in the putty.
- Copy these two files into the `/lib/firmware` directory in the Linux file system. (Actually, the image has already preinstalled these two files for the demo, so users don't need to copy them.)
- Typing the following commands to configure the FPGA.

```
mount -t configfs configfs /config  
mkdir /config/device-tree/overlays/test  
echo fpga.dtbo > /config/device-tree/overlays/test/path
```
- The LED0 on the FPGA will blink when the command is executing successfully. Now user can access the FPGA LEDs in the command line. Such as:

```
echo 1 > /sys/class/leds/fpga_led2/brightness
```

9.3 Linux LXDE Desktop BSP

This is a Linux BSP with LXDE Desktop. The LXDE Desktop is displayed on the VGA monitor attached to DE10-Standard. **Table 9-2** describes the LXDE Desktop BSP items and lists the corresponding information. The BSP provides frame buffer for VGA display. The frame buffer function is implemented in FPGA site. The HPS ddr3 is used as video buffer in the frame buffer function.

The Quartus project used by this BPS is located in the folder

Demonstration/SoC_FPGA/ControlPanel/Quartus

in the system CD. This Quartus project is developed based on the Quartus project

Demonstration/SoC_FPGA/DE10_Standard_FB.

Table 9-2 Linux LXDE Desktop BSP Information

Item	Description
BSP Location	DE10_Standard_LXDE.zip Download Link: http://de10-standard.terasic.com/cd
microSD Card	4GB at minimal
MSEL[4:0]	01010
Account	User name: root, password is not required
UART Terminal	Baud rate: 115200, Data bits: 8 Parity: None Stop Bits: 1 Flow Control: no
Quartus Project	Demonstration/SoC_FPGA/ControlPanel/Quartus in System CD (Based on Demonstration/SoC_FPGA/DE10_Standard_FB) Linux DTS File: soc_system.dts
BSP Feature	LXDE Desktop Frame Buffer ALSA (Advanced Linux Sound Architecture) Qt Library OpenCV Library GNU Toolchain USB Bluetooth Dongle driver and application example code USB WiFi Dongle driver and application example code

	USB Camera Dongle driver and OpenCV example code Control Panel Example Code (Based on Qt) Example codes for accessing peripherals connected to FPGA and HPS.
Linux Kernel Source	Source: https://github.com/terasic/linux-socfpga Branch: socfpga-4.5 Configure File: de10_standard_lxde.config under above location DTS File: arch/arm/boot/dts/socfpga_cyclone5_de10_standard_lxde.dts The file socfpga_cyclone5_de10_standard_lxde.dts is copied from the soc_system.dts file generated from the Quartus project.

9.4 OpenCL BSP

This is a Linux BSP with console mode which supports Intel SDK OpenCL. The Intel® FPGA SDK for Open Computing Language (OpenCL™) allows a user to abstract away the traditional hardware FPGA development flow for a much faster and higher level software development flow. For more details, please refer to [DE10_Standard_OpenCL.pdf](#) in the DE10-Standard System CD.

Table 9-3 lists the OpenCL BSP component reference and the related information.

Table 9-3 OpenCL BSP Information

Item	Description
BSP Location	DE10-Standard_openCL_BSP.zip Download link : http://de10-standard.terasic.com/cd
microSD Card	4GB at minimal
MSEL[4:0]	01010
Account	User name: root, password is not required
UART Terminal	Baud rate: 115200, Data bits: 8 Parity: None Stop Bits: 1 Flow Control: no
Quartus Project	de10_standard\de10_standard_sharedonly in OpenCL BSP
BSP Feature	Frame Buffer OpenCL Example Codes

Linux Kernel Source	Source: https://github.com/terasic/linux-socfpga/tree/socfpga-3.10 Branch: socfpga-3.10 Under above location: Configure File: de10_standard_opencl.config
---------------------	---



10.1 Revision History

<i>Version</i>	<i>Change Log</i>
V1.0	Initial Version
V1.0.1	Modify Section 3.6.1 Push button description
V1.0.2	Add recommended Bluetooth/WiFi/Camera USB Devices
V1.0.3	Fix the DTS file path in section 9.2 and 9.3
V1.0.4	Remove OTG cable statement in WiFi demo
V1.0.5	Modify wrong writing “stanard” and “stanarad” to standard
V1.0.6	Modify Figure 4-1, change SoCKit to DE10-Standard in the figure

10.2 Copyright Statement

Copyright © 2017 Terasic Inc. All Rights Reserved.



Стандарт Электрон Связь

Мы молодая и активно развивающаяся компания в области поставок электронных компонентов. Мы поставляем электронные компоненты отечественного и импортного производства напрямую от производителей и с крупнейших складов мира.

Благодаря сотрудничеству с мировыми поставщиками мы осуществляем комплексные и плановые поставки широчайшего спектра электронных компонентов.

Собственная эффективная логистика и склад в обеспечивает надежную поставку продукции в точно указанные сроки по всей России.

Мы осуществляем техническую поддержку нашим клиентам и предпродажную проверку качества продукции. На все поставляемые продукты мы предоставляем гарантию .

Осуществляем поставки продукции под контролем ВП МО РФ на предприятия военно-промышленного комплекса России , а также работаем в рамках 275 ФЗ с открытием отдельных счетов в уполномоченном банке. Система менеджмента качества компании соответствует требованиям ГОСТ ISO 9001.

Минимальные сроки поставки, гибкие цены, неограниченный ассортимент и индивидуальный подход к клиентам являются основой для выстраивания долгосрочного и эффективного сотрудничества с предприятиями радиоэлектронной промышленности, предприятиями ВПК и научно-исследовательскими институтами России.

С нами вы становитесь еще успешнее!

Наши контакты:

Телефон: +7 812 627 14 35

Электронная почта: sales@st-electron.ru

Адрес: 198099, Санкт-Петербург,
Промышленная ул, дом № 19, литера Н,
помещение 100-Н Офис 331