

NB3W1900L

3.3 V 100/133 MHz Differential 1:19 HCSL-Compatible Push-Pull Clock ZDB/Fanout Buffer for PCIe®

Description

The NB3W1900L differential clock buffers are designed to work in conjunction with a PCIe compliant source clock synthesizer to provide point-to-point clocks to multiple agents. The device is capable of distributing the reference clocks for Intel® QuickPath Interconnect (Intel QPI), PCIe Gen1/Gen2/Gen3. The NB3W1900L internal PLL is optimized to support 100 MHz and 133 MHz frequency operation. The NB3W1900L is developed with the low-power NMOS Push-Pull buffer type.

Features

- 19 Low Power Differential Clock Output Pairs @ 0.7 V
- Output-to-Output Skew Performance: < 85 ps
- Cycle-to-Cycle Jitter (PLL Mode): < 50ps
- Low Phase Jitter (Intel QPI, PCIe Gen 2/Gen 3 Phase Jitter Compliant)
- Input-to-Output Delay Variation: < 50 ps
- Fixed-Feedback for Lowest Input-to-Output Delay Variation
- Spread Spectrum Compatible; Tracks Input Clock Spreading for Low EMI
- 100 MHz and 133 MHz PLL Mode to Meet the Next Generation PCIe Gen2 / Gen 3 and Intel QPI Phase Jitter
- Individual OE Control via SMBus
- Low-Power NMOS Push-Pull HCSL-Compatible Outputs
- PLL Configurable for PLL Mode or Bypass Mode (Fanout Operation)
- SMBus Address Configurable to Allow Multiple Buffers in a Single Control Network
- Programmable PLL Bandwidth
- Two Tri-level Addresses Selection (Nine SMBus Addresses)
- QFN 72-pin Package, 10 mm × 10 mm
- These are Pb-Free Devices



ON Semiconductor®

<http://onsemi.com>



1 72

QFN72
MN SUFFIX
CASE 485DK

MARKING DIAGRAM

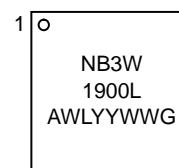

A = Assembly Location
WL = Wafer Lot
YY = Year
WW = Work Week
G = Pb-Free Package

ORDERING INFORMATION

See detailed ordering and shipping information on page 17 of this data sheet.

NB3W1900L

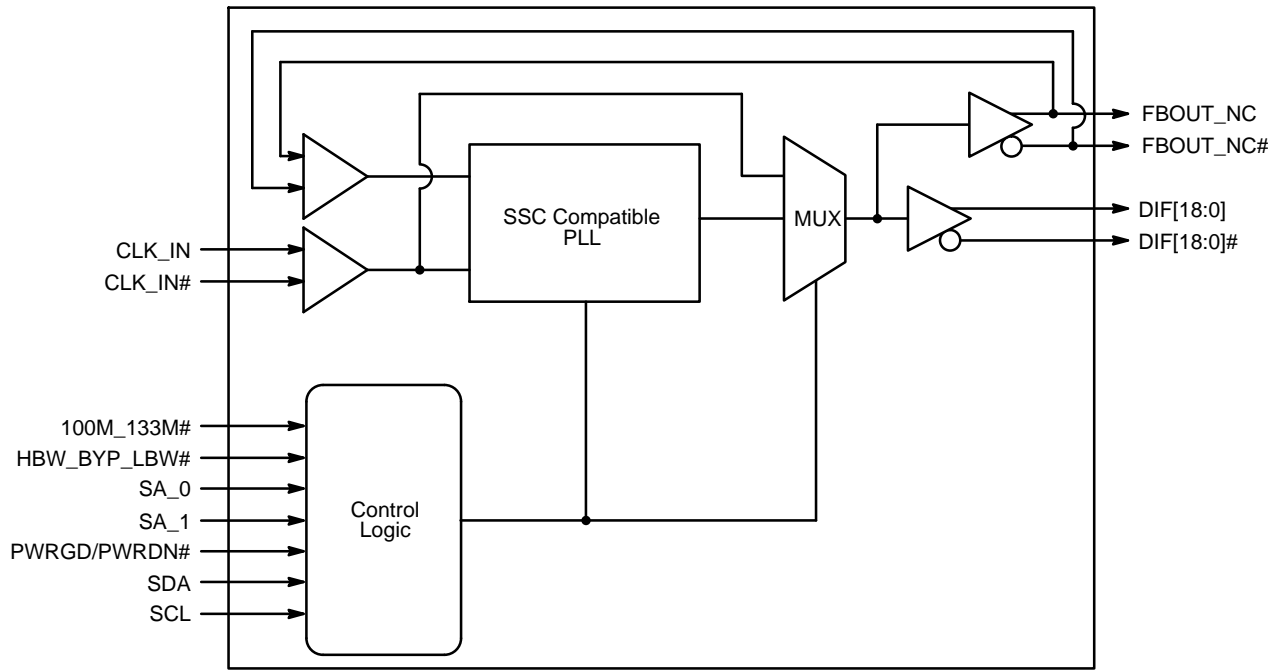

Figure 1. Simplified Block Diagram

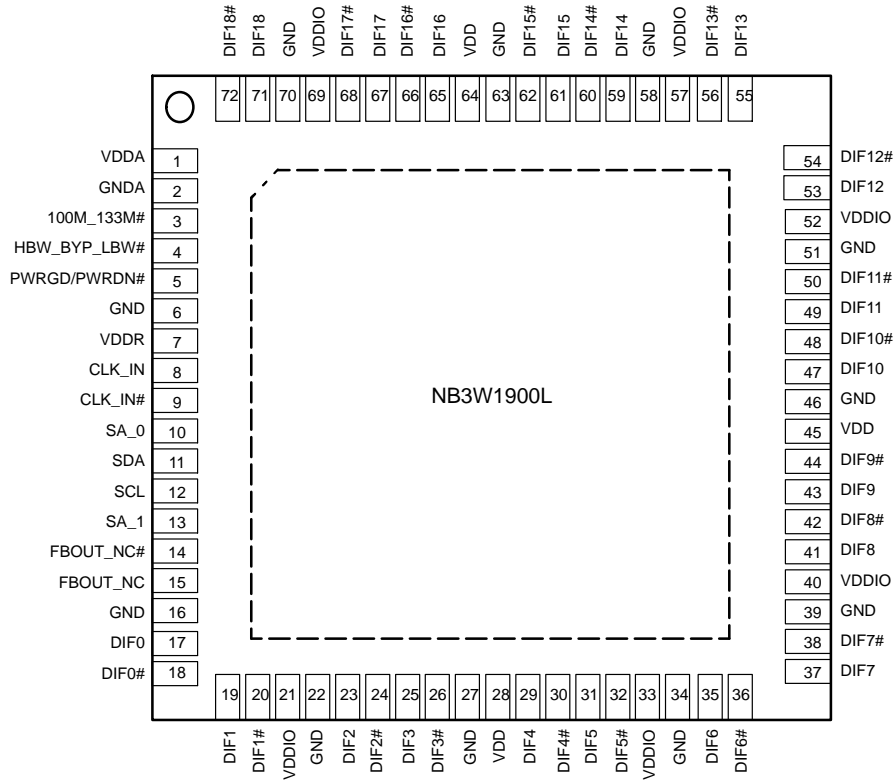

Figure 2. Pin Configuration (Top View)

NB3W1900L

Table 1. POWER DOWN PIN TABLE

Inputs		Control Bits	Outputs		PLL Stage
PWRGD/PWRDN#	CLK_IN / CLK_IN#	SMBus EN Bit	DIFx / DIFx#	FBOUT_NC / FBOUT_NC#	
0	X	X	Low/Low	Low/Low	OFF
1	Running	0	Low/Low	Running	ON
		1	Running	Running	ON

Table 2. POWER CONNECTIONS

Pin Number				Description
VDD	VDDIO	VDDR	GND	
		7	2	Analog Input
1			6	Analog PLL
28, 45, 64	21, 33, 40, 52, 57, 69		16, 22, 27, 34, 39, 46, 51, 58, 63, 70	DIF clocks

Table 3. TRI-LEVEL INPUT THRESHOLDS

Level	Voltage
Low	< 0.8 V
Mid	1.2 < Vin < 1.8 V
High	Vin > 2.2 V

Table 5. PLL OPERATING MODE

HBW_BYP_LBW#	MODE
Low	PLL Lo BW
Mid	Bypass
High	PLL Hi BW

NOTE: PLL is OFF in Bypass

Table 4. FUNCTIONALITY AT POWER-UP (PLL Mode)

100M_133M#	CLK_IN	DIFx
	MHz	MHz
1	100.00	CLK_IN
0	133.33	CLK_IN

Table 6. MODE TRI-LEVEL INPUT THRESHOLD

Level	Voltage
Low	< 0.8 V
Mid	1.2 < Vin < 1.8 V
High	Vin > 2.2 V

NB3W1900L

Table 7. NB3W1900L PIN DESCRIPTIONS

Pin Number	Pin Name	Type	Description
1	VDDA	PWR	3.3 V Power Supply for PLL core.
2	GND	GND	Ground for PLL core.
3	100M_133M#	IN	Input to select operating frequency. See functionality table for definition.
4	HBW_BYP_LBW#	IN	Tri-level input to select High BW, Bypass or low BW mode. See PLL operating mode table for definition.
5	PWRGD/PWRDN#	IN	Notifies device to sample latched inputs and start up on first high assertion, or exit power down mode on subsequent assertions. Low enters power down mode.
6	GND	GND	Ground pin
7	VDDR	PWR	3.3 V power for differential input clock (receiver). This VDD should be treated as an analog power rail and filtered appropriately.
8	CLK_IN	IN	0.7 V differential true input
9	CLK_IN#	IN	0.7 V differential complementary input
10	SA_0	IN	SMBus address bit. This is a tri-level input that works in conjunction with the SA_1 to decode 1 of 9 SMBus addresses.
11	SDA	I/O	Data pin of SMBus circuitry, 5 V tolerant
12	SCL	IN	Clock pin of SMBus circuitry, 5 V tolerant
13	SA_1	IN	SMBus address bit. This is a tri-level input that works in conjunction with the SA_0 to decode 1 of 9 SMBus addresses.
14	FBOUT_NC#	OUT	Complementary half of differential feedback output. This pin should NOT be connected to anything outside the chip. It exists to provide delay path matching to get 0 ps propagation delay.
15	FBOUT_NC	OUT	True half of differential feedback output. This pin should NOT be connected to anything outside the chip. It exists to provide delay path matching to get 0 propagation delay.
16	GND	GND	Ground pin
17	DIF0	OUT	0.7 V differential true clock output
18	DIF0#	OUT	0.7 V differential complementary clock output
19	DIF1	OUT	0.7 V differential true clock output
20	DIF1#	OUT	0.7 V differential complementary clock output
21	VDDIO	PWR	Power supply for differential outputs
22	GND	GND	Ground pin
23	DIF2	OUT	0.7 V differential true clock output
24	DIF2#	OUT	0.7 V differential complementary clock output
25	DIF3	OUT	0.7 V differential true clock output
26	DIF3#	OUT	0.7 V differential complementary clock output
27	GND	GND	Ground pin
28	VDD	PWR	Power supply nominal 3.3 V
29	DIF4	OUT	0.7 V differential true clock output
30	DIF4#	OUT	0.7 V differential complementary clock output
31	DIF5	OUT	0.7 V differential true clock output
32	DIF5#	OUT	0.7 V differential complementary clock output
33	VDDIO	PWR	Power supply for differential outputs
34	GND	GND	Ground pin
35	DIF6	OUT	0.7 V differential true clock output

1. All VDD, VDDR, VDDIO, VDDA and GND pins must be externally connected to a power supply for proper operation.

NB3W1900L

Table 7. NB3W1900L PIN DESCRIPTIONS (continued)

Pin Number	Pin Name	Type	Description
36	DIF6#	OUT	0.7 V differential complementary clock output
37	DIF7	OUT	0.7 V differential true clock output
38	DIF7#	OUT	0.7 V differential complementary clock output
39	GND	GND	Ground pin
40	VDDIO	PWR	Power supply for differential outputs
41	DIF8	OUT	0.7 V differential true clock output
42	DIF8#	OUT	0.7 V differential complementary clock output
43	DIF9	OUT	0.7 V differential true clock output
44	DIF9#	OUT	0.7 V differential complementary clock output
45	VDD	PWR	Power supply nominal 3.3 V
46	GND	GND	Ground pin
47	DIF10	OUT	0.7 V differential true clock output
48	DIF10#	OUT	0.7 V differential complementary clock output
49	DIF11	OUT	0.7 V differential true clock output
50	DIF11#	OUT	0.7 V differential complementary clock output
51	GND	GND	Ground pin
52	VDDIO	PWR	Power supply for differential outputs
53	DIF12	OUT	0.7 V differential true clock output
54	DIF12#	OUT	0.7 V differential complementary clock output
55	DIF13	OUT	0.7 V differential true clock output
56	DIF13#	OUT	0.7 V differential complementary clock output
57	VDDIO	PWR	Power supply for differential outputs
58	GND	GND	Ground pin
59	DIF14	OUT	0.7 V differential true clock output
60	DIF14#	OUT	0.7 V differential complementary clock output
61	DIF15	OUT	0.7 V differential true clock output
62	DIF15#	OUT	0.7 V differential complementary clock output
63	GND	GND	Ground pin
64	VDD	PWR	Power supply nominal 3.3 V
65	DIF16	OUT	0.7 V differential true clock output
66	DIF16#	OUT	0.7 V differential complementary clock output
67	DIF17	OUT	0.7 V differential true clock output
68	DIF17#	OUT	0.7 V differential complementary clock output
69	VDDIO	PWR	Power supply for differential outputs
70	GND	GND	Ground pin
71	DIF18	OUT	0.7 V differential true clock output
72	DIF18#	OUT	0.7 V differential complementary clock output
EP	Exposed Pad	Thermal	The Exposed Pad (EP) on the QFN-72 package bottom is thermally connected to the die for improved heat transfer out of package. The exposed pad must be attached to a heat-sinking conduit. The pad is electrically connected to the die, and must be electrically and thermally connected to GND on the PC board.

1. All VDD, VDDR, VDDIO, VDDA and GND pins must be externally connected to a power supply for proper operation.

NB3W1900L

Table 8. ABSOLUTE MAXIMUM RATINGS (Note 2)

Symbol	Parameter	Conditions	Min	Typ	Max	Unit
$V_{DD} / V_{DDA} / V_{DDR}$	3.3 V Core Supply Voltage (Note 3)				4.6	V
V_{DD} / V_{DDIO}	3.3 V Logic and Output Supply Voltage (Note 3)				4.6	V
V_{IH}	Input High Voltage	Except for SMBus Interface			$V_{DD} + 0.5$	V
V_{IH}	VIHSMB	SMBus Clock and Data Pins			5.5	V
V_{IL}	Input Low Voltage		GND – 0.5		–	V
T_s	Storage Temperature		–65		150	°C
T_J	Junction Temperature				125	°C
ESD prot.	ESD Protection (Human Body)	Human Body Model	2000			V
θ_{JA}	Thermal Resistance Junction-to-Ambient	Still air		18.1		°C/W
θ_{JC}	Thermal Resistance Junction-to-Case			5.0		°C/W

Stresses exceeding those listed in the Maximum Ratings table may damage the device. If any of these limits are exceeded, device functionality should not be assumed, damage may occur and reliability may be affected.

- Guaranteed by design and characterization, not tested in production.
- Operation under these conditions is neither implied nor guaranteed.

Table 9. ELECTRICAL CHARACTERISTICS – CLOCK INPUT PARAMETERS

($T_A = 0^\circ\text{C} - 70^\circ\text{C}$; Supply Voltage $V_{DD}/V_{DDA} = 3.3\text{ V} \pm 5\%$, $V_{DDIO} = 1.05\text{ V to } 3.3\text{ V} \pm 5\%$. See Test Loads for Loading Conditions) (Note 4)

Symbol	Parameter	Conditions	Min	Typ	Max	Unit
V_{IHDIF}	Input High Voltage – CLK_IN	Differential Inputs (single-ended measurement)	600		1150	mV
V_{ILDIF}	Input Low Voltage – CLK_IN	Differential Inputs (single-ended measurement)	$V_{SS} - 300$		300	mV
V_{COM}	Input Common Mode Voltage – CLK_IN (not spec'd)	Common Mode Input Voltage	300		1000	mV
V_{SWING}	Input Amplitude – CLK_IN not spec'd	Peak to Peak Value	300		1450	mV
dv/dt	Input Slew Rate – CLK_IN (Note 5)	Measured Differentially	0.4		8	V/ns
I_{IN}	Input Leakage Current	$V_{IN} = V_{DD}$, $V_{IN} = \text{GND}$	–5		5	μA
d_{tin}	Input Duty Cycle	Measurement from Differential Waveform	45		55	%
J_{DIFin}	Input Jitter – Cycle to Cycle	Differential Measurement	0		125	ps

Product parametric performance is indicated in the Electrical Characteristics for the listed test conditions, unless otherwise noted. Product performance may not be indicated by the Electrical Characteristics if operated under different conditions.

- Guaranteed by design and characterization, not tested in production.
- Slew rate measured through $\pm 75\text{ mV}$ window centered around differential zero

Table 10. ELECTRICAL CHARACTERISTICS–INPUT/SUPPLY/Common OUTPUT PARAMETERS

($T_A = 0^\circ\text{C} - 70^\circ\text{C}$; Supply Voltage $V_{DD}/V_{DDA} = 3.3\text{ V} \pm 5\%$, $V_{DDIO} = 1.05\text{ V to } 3.3\text{ V} \pm 5\%$. See Test Loads for Loading Conditions) (Note 6)

Symbol	Parameter	Conditions	Min	Typ	Max	Unit
V_{IH}	Input High Voltage	Single-ended inputs, except SMBus, low threshold and tri-level inputs	2		$V_{DD} + 0.3$	V
V_{IL}	Input Low Voltage	Single-ended inputs, except SMBus, low threshold and tri-level inputs	GND – 0.3		0.8	V
I_{IN}	Input Current	Single-ended inputs, $V_{IN} = \text{GND}$, $V_{IN} = V_{DD}$	–5		5	μA
V_{IH_FS}	Input High Voltage	(Note 7)	0.7		$V_{DD} + 0.3$	V
V_{IL_FS}	Input Low Voltage	(Note 7)	GND – 0.3		0.35	V

NB3W1900L

Table 10. ELECTRICAL CHARACTERISTICS—INPUT/SUPPLY/Common Output Parameters (continued)

(T_A = 0°C – 70°C; Supply Voltage V_{DD}/V_{DDA} = 3.3 V ±5%, V_{DDIO} = 1.05 V to 3.3 V ±5%. See Test Loads for Loading Conditions) (Note 6)

Symbol	Parameter	Conditions	Min	Typ	Max	Unit
F _{ibyp}	Input Frequency	V _{DD} = 3.3 V, Bypass mode (Note 8)	33		150	MHz
F _{ipll}		V _{DD} = 3.3 V, 100.00 MHz PLL mode (Note 8)	99	100.00	101	MHz
F _{ipll}		V _{DD} = 3.3 V, 133.33 MHz PLL mode (Note 8)	132.33	133.33	134.33	MHz
L _{pin}	Pin Inductance				7	nH
C _{IN}	Capacitance	Logic Inputs, except CLK_IN	1.5		5	pF
C _{INCLK_IN}		CLK_IN differential clock inputs (Note 10)	1.5		2.7	pF
C _{OUT}		Output pin capacitance			6	pF
T _{STAB}	Clk Stabilization (Note 8)	From V _{DD} Power-Up and after input clock stabilization or de-assertion of PD# to 1st clock			1	ms
f _{MODIN}	Input SS Modulation Frequency	Allowable Frequency (Triangular Modulation)	30		33	kHz
t _{LATOE#}	OE# Latency	DIF start after OE# assertion DIF stop after OE# de-assertion	4		12	clocks
t _{DRVDPD}	Tdrive_PD# (Note 9)	DIF output enable after PD# de-assertion			300	μs
t _F	Tfall (Note 8)	Fall time of control inputs			5	ns
t _R	Trise (Note 8)	Rise time of control inputs			5	ns
V _{ILSMB}	SMBus Input Low Voltage				0.8	V
V _{IHSMB}	SMBus Input High Voltage		2.1		V _{DD} SMB	V
V _{OLSMB}	SMBus Output Low Voltage	@ I _{PULLUP}			0.4	V
I _{PULLUP}	SMBus Sink Current	@ V _{OL}	4			mA
V _{DD} SMB	Nominal Bus Voltage	3 V to 5 V ±10%	2.7		5.5	V
t _{RSMB}	SCL/SDA Rise Time	(Max V _{IL} – 0.15) to (Min V _{IH} + 0.15)			1000	ns
t _{FSMB}	SCL/SDA Fall Time	(Min V _{IH} + 0.15) to (Max V _{IL} – 0.15)			300	ns
f _{MAXSMB}	SMBus Operating Frequency (Note 11)	Maximum SMBus operating frequency			100	kHz

Product parametric performance is indicated in the Electrical Characteristics for the listed test conditions, unless otherwise noted. Product performance may not be indicated by the Electrical Characteristics if operated under different conditions.

6. Guaranteed by design and characterization, not tested in production.

7. 100M_133M# Frequency Select (FS).

8. Control input must be monotonic from 20% to 80% of input swing.

9. Time from de-assertion until outputs are > 200 mV

10. CLK_IN input

11. The differential input clock must be running for the SMBus to be active

NB3W1900L

Table 11. ELECTRICAL CHARACTERISTICS – DIF 0.7 V LOW POWER DIFFERENTIAL OUTPUTS

($T_A = 0^\circ\text{C} - 70^\circ\text{C}$; Supply Voltage $V_{DD}/V_{DDA} = 3.3\text{ V} \pm 5\%$, $V_{DDIO} = 1.05\text{ V}$ to $3.3\text{ V} \pm 5\%$. See Test Loads for Loading Conditions) (Note 12)

Symbol	Parameter	Conditions	Min	Typ	Max	Unit
dV/dt	Slew Rate (Notes 13, 14)	Scope averaging on	1		4	V/ns
$\Delta\text{dV}/\text{dt}$	Slew Rate Matching (Notes 13, 15)	Slew rate matching, Scope averaging on			20	%
V_{High}	Voltage High	Statistical measurement on single-ended signal using oscilloscope math function. (Scope averaging on)	660		850	mV
V_{Low}	Voltage Low		-150		150	
V_{max}	Max Voltage	Measurement on single ended signal using Absolute value. (Scope averaging off)			1150	mV
V_{min}	Min Voltage		-300			
V_{swing}	Vswing (Note 13)	Scope averaging off	300			mV
$V_{\text{cross_abs}}$	Crossing Voltage (abs) (Note 16)	Scope averaging off	250		550	mV
ΔV_{cross}	Crossing Voltage (var) (Note 17)	Scope averaging off			140	mV

Product parametric performance is indicated in the Electrical Characteristics for the listed test conditions, unless otherwise noted. Product performance may not be indicated by the Electrical Characteristics if operated under different conditions.

12. Guaranteed by design and characterization, not tested in production. $C_L = 2\text{ pF}$ with $R_S = 33\ \Omega$ for $Z_0 = 50\ \Omega$ ($100\ \Omega$ differential trace impedance).

13. Measured from differential waveform

14. Slew rate is measured through the V_{swing} voltage range centered around differential 0 V. This results in a $\pm 150\text{ mV}$ window around differential 0 V.

15. Matching applies to rising edge rate for Clock and falling edge rate for Clock#. It is measured using a $\pm 75\text{ mV}$ window centered on the average cross point where Clock rising meets Clock# falling. The median cross point is used to calculate the voltage thresholds the oscilloscope is to use for the edge rate calculations.

16. $V_{\text{cross_abs}}$ is defined as voltage where Clock = Clock# measured on a component test board and only applies to the differential rising edge (i.e. Clock rising and Clock# falling).

17. The total variation of all V_{cross} measurements in any particular system. Note that this is a subset of $V_{\text{cross_min/max}}$ (V_{cross} absolute) allowed. The intent is to limit V_{cross} induced modulation by setting ΔV_{cross} to be smaller than V_{cross} absolute.

NB3W1900L

Table 12. ELECTRICAL CHARACTERISTICS – CURRENT CONSUMPTION

(T_A = 0°C – 70°C; Supply Voltage V_{DD}/V_{DDA} = 3.3 V ±5%, V_{DDIO} = 1.05 V to 3.3 V ±5%. See Test Loads for Loading Conditions) (Note 18)

Symbol	Parameter	Conditions	Min	Typ	Max	Unit
I _{DDVDD}	Operating Supply Current	All outputs @ 100.00 MHz, C _L = 2 pF; Z _o = 85 Ω			50	mA
I _{DDVDDA/R}		All outputs @ 100.00 MHz, C _L = 2 pF; Z _o = 85 Ω			30	mA
I _{DDVDDIO}		All outputs @ 100.00 MHz, C _L = 2 pF; Z _o = 85 Ω			200	mA
I _{DDVDDPD}	Powerdown Current (Note 19)	All differential pairs low/low			4	mA
I _{DDVDDA/RPD}		All differential pairs low/low			5	mA
I _{DDVDDIOPD}		All differential pairs low/low			0.2	mA

Product parametric performance is indicated in the Electrical Characteristics for the listed test conditions, unless otherwise noted. Product performance may not be indicated by the Electrical Characteristics if operated under different conditions.

18. Guaranteed by design and characterization, not tested in production.

19. With input clock running. Stopping the input clock will result in lower numbers.

Table 13. ELECTRICAL CHARACTERISTICS – SKEW AND DIFFERENTIAL JITTER PARAMETERS

(T_A = 0°C – 70°C; Supply Voltage V_{DD}/V_{DDA} = 3.3 V ±5%, V_{DDIO} = 1.05 to 3.3 V ±5%. See Test Loads for Loading Conditions)

Symbol	Parameter	Conditions	Min	Typ	Max	Unit
t _{SPO_PLL}	CLK_IN, DIF[x:0] (Notes 20, 21, 23, 24 and 27)	Input-to-Output Skew in PLL mode nominal value @ 25°C, 3.3 V	-100		100	ps
t _{PD_BYP}	CLK_IN, DIF[x:0] (Notes 20, 21, 22, 24 and 27)	Input-to-Output Skew in Bypass mode nominal value @ 25°C, 3.3 V	2.5		4.5	ns
t _{DSPO_PLL}	CLK_IN, DIF[x:0] (Notes 20, 21, 22, 24 and 27)	Input-to-Output Skew Variation in PLL mode across voltage and temperature			100	ps
t _{DSPO_BYP}	CLK_IN, DIF[x:0] (Notes 20, 21, 22, 24 and 27)	Input-to-Output Skew Variation in Bypass mode across voltage and temperature	-250		250	ps
t _{DTE}	CLK_IN, DIF[x:0] (Notes 20, 21, 22, 24 and 27)	Random Differential Tracking error between two NB3W1900L devices in Hi BW Mode			5	ps (rms)
t _{DSSTE}	CLK_IN, DIF[x:0] (Notes 20, 21, 22, 24 and 27)	Random Differential Spread Spectrum Tracking error between two NB3W1900L devices in Hi BW Mode.			75	ps
t _{SKEW_ALL}	DIF[x:0] (Notes 20, 21, 22 and 27)	Output-to-Output Skew across all outputs (Common to Bypass and PLL mode)			85	ps
j _{peak-hibw}	PLL Jitter Peaking (Notes 26 and 27)	HBW_BYP_LBW# = 1	0		2.5	dB
j _{peak-lobw}	PLL Jitter Peaking (Notes 26 and 27)	HBW_BYP_LBW# = 0	0		2	dB
p _{lHIBW}	PLL Bandwidth (Notes 27 and 28)	HBW_BYP_LBW# = 1	2		4	MHz
p _{lLOBW}	PLL Bandwidth (Notes 27 and 28)	HBW_BYP_LBW# = 0	0.7		1.4	MHz
t _{DC}	Duty Cycle (Note 20)	Measured differentially, PLL Mode	45	50	55	%
t _{DCD}	Duty Cycle Distortion (Notes 20 and 29)	Measured differentially, Bypass Mode @ 100.00 MHz	-2	0	2	%
t _{jyc-cyc}	Jitter, Cycle-to-Cycle (Notes 20 and 30)	PLL mode			50	ps
		Additive Jitter in Bypass Mode			50	ps

Product parametric performance is indicated in the Electrical Characteristics for the listed test conditions, unless otherwise noted. Product performance may not be indicated by the Electrical Characteristics if operated under different conditions.

20. Measured into fixed 2 pF load cap. Input to output skew is measured at the first output edge following the corresponding input.

21. Measured from differential cross-point to differential cross-point. This parameter can be tuned with external feedback path, if present.

22. All Bypass Mode Input-to-Output specs refer to the timing between an input edge and the specific output edge created by it.

23. This parameter is deterministic for a given device

24. Measured with scope averaging on to find mean value.

25. t is the period of the input clock

26. Measured as maximum pass band gain. At frequencies within the loop BW, highest point of magnification is called PLL jitter peaking.

27. Guaranteed by design and characterization, not tested in production.

28. Measured at 3 db down or half power point.

29. Duty cycle distortion is the difference in duty cycle between the output and the input clock when the device is operated in bypass mode.

30. Measured from differential waveform

NB3W1900L

Table 14. ELECTRICAL CHARACTERISTICS – PHASE JITTER PARAMETERS

(T_A = 0°C – 70°C; Supply Voltage V_{DD}/V_{DDA} = 3.3 V ±5%, V_{DDIO} = 1.05 V to 3.3 V ±5%. See Test Loads for Loading Conditions) (Note 31)

Symbol	Parameter	Conditions	Min	Typ	Max	Unit
t _{jphPCleG1}	Phase Jitter, PLL Mode	PCle Gen 1 (Notes 32 and 33)			86	ps (p-p)
t _{jphPCleG2}		PCle Gen 2 Lo Band 10 kHz < f < 1.5 MHz (Note 32)			3	ps (rms)
		PCle Gen 2 High Band 1.5 MHz < f < Nyquist (50 MHz) (Note 32)			3.1	ps (rms)
t _{jphPCleG3}		PCle Gen 3 (PLL BW of 2–4 MHz, CDR = 10 MHz) (Notes 32, 33 and 34)			1	ps (rms)
t _{jphQPI_SMI}		QPI & SMI (100.00 MHz or 133.33 MHz, 4.8 Gb/s, 6.4 Gb/s 12UI) (Note 35)			0.5	ps (rms)
		QPI & SMI (100.00 MHz, 8.0 Gb/s, 12UI) (Note 35)			0.3	ps (rms)
		QPI & SMI (100.00 MHz, 9.6 Gb/s, 12UI) (Note 35)			0.2	ps (rms)
t _{jphPCleG1}	Additive Phase Jitter, Bypass Mode	PCle Gen 1 (Notes 32 and 33)			10	ps (p-p)
t _{jphPCleG2}		PCle Gen 2 Lo Band 10 kHz < f < 1.5 MHz (Notes 32 and 36)			0.3	ps (rms)
		PCle Gen 2 High Band 1.5 MHz < f < Nyquist (50 MHz) (Notes 32 and 36)			0.7	ps (rms)
t _{jphPCleG3}		PCle Gen 3 (PLL BW of 2–4 MHz, CDR = 10 MHz) (Notes 32, 34 and 36)			0.3	ps (rms)
t _{jphQPI_SMI}		QPI & SMI (100.00 MHz or 133.33 MHz, 4.8 Gb/s, 6.4 Gb/s 12UI) (Notes 35 and 36)			0.3	ps (rms)
		QPI & SMI (100.00 MHz, 8.0 Gb/s, 12UI) (Notes 35 and 36)			0.1	ps (rms)
		QPI & SMI (100.00 MHz, 9.6 Gb/s, 12UI) (Notes 35 and 36)			0.1	ps (rms)

Product parametric performance is indicated in the Electrical Characteristics for the listed test conditions, unless otherwise noted. Product performance may not be indicated by the Electrical Characteristics if operated under different conditions.

31. Applies to all outputs.

32. See <http://www.pcisig.com> for complete specs

33. Sample size of at least 100k cycles. This figures extrapolates to 108 ps pk-pk @ 1M cycles for a BER of 1–12.

34. Subject to final ratification by PCI SIG.

35. Calculated from Intel-supplied Clock Jitter Tool v 1.6.3

36. For RMS figures, additive jitter is calculated by solving the following equation: (Additive jitter)² = (total jitter)² – (input jitter)²

NB3W1900L

Table 15. CLOCK PERIODS-DIFFERENTIAL OUTPUTS WITH SPREAD SPECTRUM DISABLED

SSC OFF	Center Freq. MHz	Measurement Window							Unit	Notes
		1 Clock	1 μ s	0.1 s	0.1s	0.1s	1 μ s	1 Clock		
		-c 2c jitter AbsPer Min	-SSC Short-Term Average Min	- ppm Long-Term Average Min	0 ppm Period Nominal	+ ppm Long-Term Average Max	+SSC Short-Term Average Max	+c2c jitter Abs Per Max		
DIF	1 00.00	9.94900		9.99900	10 .0000 0	1 0.001 00		10.05100	ns	37, 38, 39
	1 33.33	7.44925		7.49925	7.50000	7.50075		7.55 075	ns	37, 38, 40

37. Guaranteed by design and characterization, not tested in production.

38. All Long Term Accuracy specifications are guaranteed with the assumption that the input clock complies with CK420BQ/CK410B+ accuracy requirements (± 100 ppm). The NB3W1900L it self does not contribute to ppm error.

39. Driven by SRC out put of main clock, 100.00 MHz PLL Mode or Bypass mode.

40. Driven by CPU out put of main clock, 133.33 MHz PLL Mode or Bypass mode.

Table 16. CLOCK PERIODS-DIFFERENTIAL OUTPUTS WITH SPREAD SPECTRUM ENABLED

SSC ON	Center Freq. MHz	Measurement Window							Unit	Notes
		1 Clock	1 μ s	0.1s	0.1s	0.1s	1 μ s	1 Clock		
		-c2c jitter AbsPer Min	-SSC Short-Term Average Min	- ppm Long-Term Average Min	0 ppm Period Nominal	+ ppm Long-Term Average Max	+SSC Short-Term Average Max	+c2c jitter AbsPer Max		
DIF	99.75	9.94906	9. 99906	10.02406	10.02506	10.02607	10.05107	10.10107	ns	41, 42, 43
	133.00	7.44930	7. 49930	7.51805	7.51880	7.51955	7.53830	7.58830	ns	41, 42, 44

41. Guaranteed by design and characterization, not tested in production.

42. All Long Term Accuracy specifications are guaranteed with the assumption that the input clock complies with CK420BQ/ CK410B+ accuracy requirements (± 100 ppm). The NB3W1900L it self does not contribute to ppm error.

43. Driven by SRC out put of main clock, 100.00 MHz PLL Mode or Bypass mode.

44. Driven by CPU out put of main clock, 133.33 MHz PLL Mode or Bypass mode.

TEST LOADS

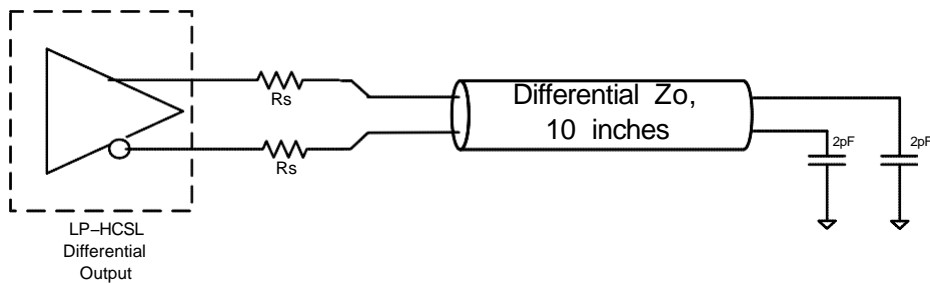

Figure 3. NB3W1900L Differential Test Loads

Table 17. DIFFERENTIAL OUTPUT TERMINATIONS

DIF Zo (Ω)	Rs (Ω)
100	33
85	27

GENERAL SMBus SERIAL INTERFACE INFORMATION

How to Write

- Controller (host) sends a start bit
- Controller (host) sends the write address
- Clock (device) will **acknowledge**
- Controller (host) sends the beginning byte location = N
- Clock (device) will **acknowledge**
- Controller (host) sends the byte count = X
- Clock (device) will **acknowledge**
- Controller (host) starts sending Byte N through Byte N+X-1
- Clock (device) will **acknowledge** each byte **one at a time**
- Controller (host) sends a Stop bit

- Controller (host) sends the beginning byte location = N
- Clock (device) will **acknowledge**
- Controller (host) will send a separate start bit
- Controller (host) sends the read address
- Clock (device) will **acknowledge**
- Clock (device) will send the data byte count = X
- Clock (device) sends Byte N + X - 1
- Clock (device) sends **Byte 0 through Byte X (if X_(H) was written to Byte 8)**
- Controller (host) will need to acknowledge each byte
- Controller (host) will send a not acknowledge bit
- Controller (host) will send a stop bit

Table 18. INDEX BLOCK WRITE OPERATION

Controller (Host)			Clock (Device)
T	starT bit		X Byte
Slave Address			
WR	WRite		
		ACK	
Beginning Byte = N			
		ACK	
Data Byte Count = X			
		ACK	
Beginning Byte N			
		ACK	
O			
O		O	
O		O	
		O	
Byte N + X - 1			
		ACK	
P	stoP bit		

Table 19. INDEX BLOCK READ OPERATION

Controller (Host)			Clock (Device)
T	starT bit		X Byte
Slave Address			
WR	WRite		
		ACK	
Beginning Byte = N			
		ACK	
RT	Repeat starT		
Slave Address			
RD	ReaD		
		ACK	
ACK		Data Byte Count = X	
ACK		Beginning Byte N	
ACK			
ACK			
ACK			
ACK			
ACK		Byte N + X - 1	
N	Not acknowledge		
P	stoP bit		

How to Read

- Controller (host) will send a start bit
- Controller (host) sends the write address
- Clock (device) will **acknowledge**

NB3W1900L

Table 20. SMBus ADDRESSING

SA_1 and SA_0	SMBus 8-bit Address (Rd/Wrt bit = 0)
00	D8
0M	DA
01	DE
M0	C2
MM	C4
M1	C6
10	CA
1M	CC
11	CE

Table 21. SMBus Table: PLL MODE, AND FREQUENCY SELECT REGISTER

Byte 0	Pin #	Name	Control Function	Type	0	1	Default
Bit 7	4	PLL Mode 1	PLL Operating Mode Rd back 1	R	See PLL Operating Mode Readback Table		Latch
Bit 6	4	PLL Mode 0	PLL Operating Mode Rd back 0	R			Latch
Bit 5	72/71	DIF_18_En	Output Control overrides OE# pin	RW	Low/Low	Enable	1
Bit 4	68/67	DIF_17_En	Output Control overrides OE# pin	RW	Low/Low	Enable	1
Bit 3	66/65	DIF_16_En	Output Control overrides OE# pin	RW	Low/Low	Enable	1
Bit 2		Reserved					0
Bit 1		Reserved					0
Bit 0	3	100M_133M#	Frequency Select Readback	R	133 MHz	100 MHz	Latch

Table 22. SMBus TABLE: OUTPUT CONTROL REGISTER

Byte 1	Pin #	Name	Control Function	Type	0	1	Default
Bit 7	38/37	DIF_7_En	Output Control overrides OE# pin	RW	Low/Low	Enable	1
Bit 6	35/36	DIF_6_En	Output Control overrides OE# pin	RW			1
Bit 5	31/32	DIF_5_En	Output Control overrides OE# pin	RW			1
Bit 4	29/30	DIF_4_En	Output Control overrides OE# pin	RW			1
Bit 3	25/26	DIF_3_En	Output Control overrides OE# pin	RW			1
Bit 2	23/24	DIF_2_En	Output Control overrides OE# pin	RW			1
Bit 1	19/20	DIF_1_En	Output Control overrides OE# pin	RW			1
Bit 0	17/18	DIF_0_En	Output Control overrides OE# pin	RW			1

Table 23. SMBus TABLE: OUTPUT CONTROL REGISTER

Byte 2	Pin #	Name	Control Function	Type	0	1	Default
Bit 7	62/61	DIF_15_En	Output Control overrides OE# pin	RW	Low/Low	Enable	1
Bit 6	60/59	DIF_14_En	Output Control overrides OE# pin	RW			1
Bit 5	56/55	DIF_13_En	Output Control overrides OE# pin	RW			1
Bit 4	54/53	DIF_12_En	Output Control overrides OE# pin	RW			1
Bit 3	50/49	DIF_11_En	Output Control overrides OE# pin	RW			1
Bit 2	48/47	DIF_10_En	Output Control overrides OE# pin	RW			1
Bit 1	44/43	DIF_9_En	Output Control overrides OE# pin	RW			1
Bit 0	42/41	DIF_8_En	Output Control overrides OE# pin	RW			1

NB3W1900L

Table 24. SMBus TABLE: RESERVED REGISTER

Byte 3	Pin #	Name	Control Function	Type	0	1	Default
Bit 7			Reserved				0
Bit 6			Reserved				0
Bit 5			Reserved				0
Bit 4			Reserved				0
Bit 3			Reserved				0
Bit 2			Reserved				0
Bit 1			Reserved				0
Bit 0			Reserved				0

Table 25. SMBus TABLE: RESERVED REGISTER

Byte 4	Pin #	Name	Control Function	Type	0	1	Default
Bit 7			Reserved				0
Bit 6			Reserved				0
Bit 5			Reserved				0
Bit 4			Reserved				0
Bit 3			Reserved				0
Bit 2			Reserved				0
Bit 1			Reserved				0
Bit 0			Reserved				0

Table 26. SMBus TABLE: VENDOR & REVISION ID REGISTER

Byte 5	Pin #	Name	Control Function	Type	0	1	Default
Bit 7	–	RID3	REVISION ID	R	–	–	X
Bit 6	–	RID2		R	–	–	X
Bit 5	–	RID1		R	–	–	X
Bit 4	–	RID0		R	–	–	X
Bit 3	–	VID3	VENDOR ID	R	–	–	1
Bit 2	–	VID2		R	–	–	1
Bit 1	–	VID1		R	–	–	1
Bit 0	–	VID0		R	–	–	1

Table 27. SMBus TABLE: DEVICE ID

Byte 6	Pin #	Name	Control Function	Type	0	1	Default
Bit 7	–		Device ID 7 (MSB)	R	Device ID is 130 decimal or 82 hex.		1
Bit 6	–		Device ID 6	R			1
Bit 5	–		Device ID 5	R			0
Bit 4	–		Device ID 4	R			1
Bit 3	–		Device ID 3	R			1
Bit 2	–		Device ID 2	R			0
Bit 1	–		Device ID 1	R			1
Bit 0	–		Device ID 0	R			1

NB3W1900L

Table 28. SMBus TABLE: BYTE COUNT REGISTER

Byte 7	Pin #	Name	Control Function	Type	0	1	Default
Bit 7			Reserved				0
Bit 6			Reserved				0
Bit 5			Reserved				0
Bit 4	–	BC4	Writing to this register configures how many bytes will be read back.	RW	Default value is 8 hex, so 9 bytes (0 to 8) will be read back by default.		0
Bit 3	–	BC3		RW			1
Bit 2	–	BC2		RW			0
Bit 1	–	BC1		RW			0
Bit 0	–	BC0		RW			0

Table 29. SMBus TABLE: RESERVED REGISTER

Byte 8	Pin #	Name	Control Function	Type	0	1	Default
Bit 7			Reserved				0
Bit 6			Reserved				0
Bit 5			Reserved				0
Bit 4			Reserved				0
Bit 3			Reserved				0
Bit 2			Reserved				0
Bit 1			Reserved				0
Bit 0			Reserved				0

Table 30. DIF REFERENCE CLOCK

Common R Recommendations for Differential Routing	Dimension or Value	Unit
L1 length, route as non-coupled 50 Ω trace (see Figure 4)	0.5 max	inch
L2 length, route as non-coupled 50 Ω trace (see Figure 4)	0.2 max	inch
L3 length, route as non-coupled 50 Ω trace (see Figure 4)	0.2 max	inch
Rs (100 Ω differential traces) (see Figure 4)	33	Ω
Rs (85 Ω differential traces) (see Figure 4)	27	Ω

Down Device Differential Routing	Dimension or Value	Unit
L4 length, route as coupled micro strip 100 Ω differential trace (see Figure 4)	2 min to 16 max	inch
L4 length, route as coupled strip line 100 Ω differential trace (see Figure 4)	1.8 min to 14.4 max	inch

Differential Routing to PCI Express Connector	Dimension or Value	Unit
L4 length, route as coupled microstrip 100 Ω differential trace (see Figure 5)	0.25 to 14 max	inch
L4 length, route as coupled stripline 100 Ω differential trace (see Figure 5)	0.225 min to 12.6 max	inch

NB3W1900L

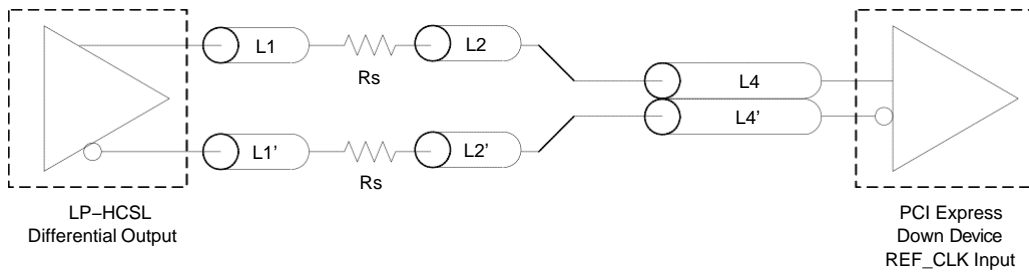

Figure 4. Down Device Routing

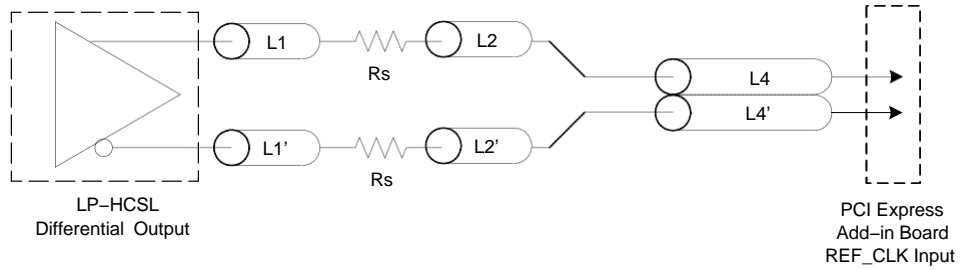

Figure 5. PCI Express Connector Routing

Table 31. CABLE CONNECTED AC COUPLED APPLICATION (Figure 6)

Component	Value	Note
R5a, R5b	8.2k 5%	
R6a, R6b	1k 5%	
Cc	0.1 μ F	
Vcm	0.350 V	

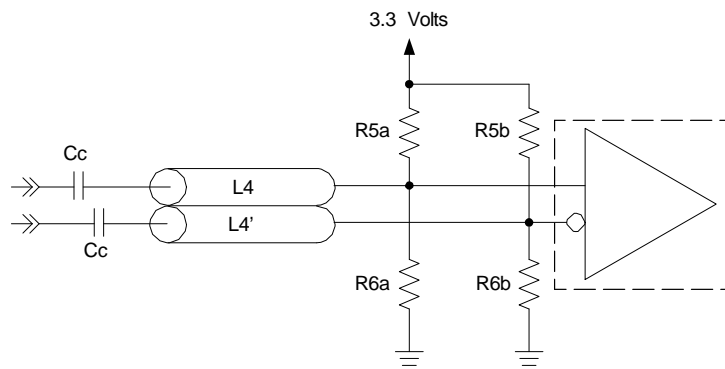

Figure 6.

NB3W1900L

POWER FILTERING EXAMPLE

Ferrite Bead Power Filtering

Recommended ferrite bead filtering equivalent to the following:

600 Q impedance at 100.00 MHz, $\leq 0.1 \text{ Q DCR max.}$, $\geq 400 \text{ mA current rating.}$

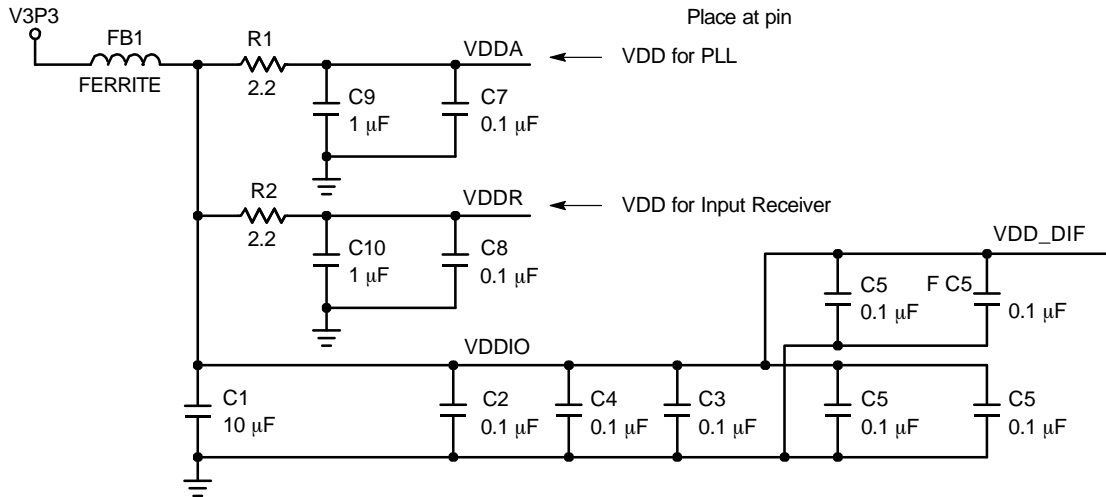

Figure 7. Schematic Example of the NB3W1900L Power Filtering

Table 32. ORDERING INFORMATION

Device	Package	Shipping†
NB3W1900LMNG	QFN-72 (Pb-Free)	168 Units / Tray
NB3W1900LMNTXG	QFN-72 (Pb-Free)	1,000 / Tape & Reel

†For information on tape and reel specifications, including part orientation and tape sizes, please refer to our Tape and Reel Packaging Specifications Brochure, BRD8011/D.

NB3W1900L

PACKAGE DIMENSIONS

QFN72 10x10, 0.5P
CASE 485DK
ISSUE O

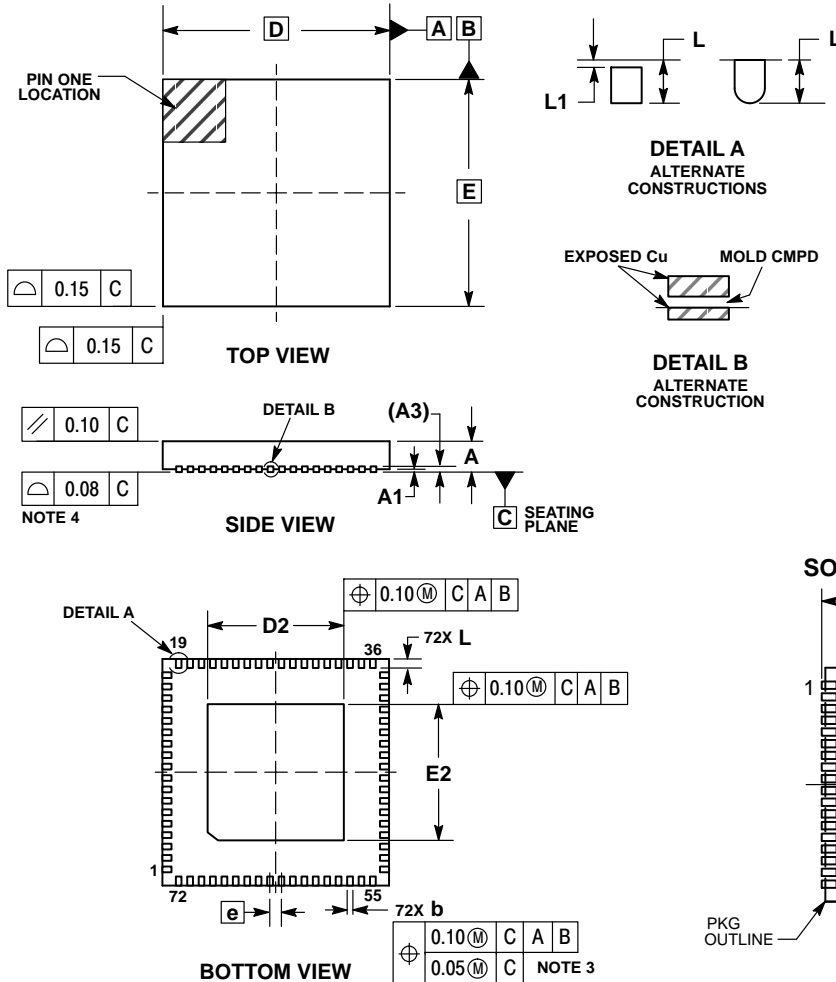

NOTES:

1. DIMENSIONING AND TOLERANCING PER ASME Y14.5M, 1994.
2. CONTROLLING DIMENSIONS: MILLIMETERS.
3. DIMENSION b APPLIES TO PLATED TERMINAL AND IS MEASURED BETWEEN 0.15 AND 0.25mm FROM THE TERMINAL TIP.
4. COPLANARITY APPLIES TO THE EXPOSED PAD AS WELL AS THE TERMINALS.

MILLIMETERS		
DIM	MIN	MAX
A	0.80	1.00
A1	0.00	0.05
A3	0.20 REF	
b	0.18	0.30
D	10.00 BSC	
D2	5.85	6.15
E	10.00 BSC	
E2	5.85	6.15
e	0.50 BSC	
L	0.30	0.50
L1	0.00	0.15

Intel is a registered trademark of Intel Corporation.
PCIe and PCI-SIG are registered trademarks of PCI-SIG.

ON Semiconductor and **ON** are registered trademarks of Semiconductor Components Industries, LLC (SCILLC). SCILLC owns the rights to a number of patents, trademarks, copyrights, trade secrets, and other intellectual property. A listing of SCILLC's product/patent coverage may be accessed at www.onsemi.com/site/pdf/Patent-Marking.pdf. SCILLC reserves the right to make changes without further notice to any products herein. SCILLC makes no warranty, representation or guarantee regarding the suitability of its products for any particular purpose, nor does SCILLC assume any liability arising out of the application or use of any product or circuit, and specifically disclaims any and all liability, including without limitation special, consequential or incidental damages. "Typical" parameters which may be provided in SCILLC data sheets and/or specifications can and do vary in different applications and actual performance may vary over time. All operating parameters, including "Typicals" must be validated for each customer application by customer's technical experts. SCILLC does not convey any license under its patent rights nor the rights of others. SCILLC products are not designed, intended, or authorized for use as components in systems intended for surgical implant into the body, or other applications intended to support or sustain life, or for any other application in which the failure of the SCILLC product could create a situation where personal injury or death may occur. Should Buyer purchase or use SCILLC products for any such unintended or unauthorized application, Buyer shall indemnify and hold SCILLC and its officers, employees, subsidiaries, affiliates, and distributors harmless against all claims, costs, damages, and expenses, and reasonable attorney fees arising out of, directly or indirectly, any claim of personal injury or death associated with such unintended or unauthorized use, even if such claim alleges that SCILLC was negligent regarding the design or manufacture of the part. SCILLC is an Equal Opportunity/Affirmative Action Employer. This literature is subject to all applicable copyright laws and is not for resale in any manner.

PUBLICATION ORDERING INFORMATION

LITERATURE FULFILLMENT:
Literature Distribution Center for ON Semiconductor
P.O. Box 5163, Denver, Colorado 80217 USA
Phone: 303-675-2175 or 800-344-3860 Toll Free USA/Canada
Fax: 303-675-2176 or 800-344-3867 Toll Free USA/Canada
Email: orderlit@onsemi.com

N. American Technical Support: 800-282-9855 Toll Free
USA/Canada
Europe, Middle East and Africa Technical Support:
Phone: 421 33 790 2910
Japan Customer Focus Center
Phone: 81-3-5817-1050

ON Semiconductor Website: www.onsemi.com
Order Literature: <http://www.onsemi.com/orderlit>
For additional information, please contact your local Sales Representative



Стандарт Электрон Связь

Мы молодая и активно развивающаяся компания в области поставок электронных компонентов. Мы поставляем электронные компоненты отечественного и импортного производства напрямую от производителей и с крупнейших складов мира.

Благодаря сотрудничеству с мировыми поставщиками мы осуществляем комплексные и плановые поставки широчайшего спектра электронных компонентов.

Собственная эффективная логистика и склад в обеспечивает надежную поставку продукции в точно указанные сроки по всей России.

Мы осуществляем техническую поддержку нашим клиентам и предпродажную проверку качества продукции. На все поставляемые продукты мы предоставляем гарантию .

Осуществляем поставки продукции под контролем ВП МО РФ на предприятия военно-промышленного комплекса России , а также работаем в рамках 275 ФЗ с открытием отдельных счетов в уполномоченном банке. Система менеджмента качества компании соответствует требованиям ГОСТ ISO 9001.

Минимальные сроки поставки, гибкие цены, неограниченный ассортимент и индивидуальный подход к клиентам являются основой для выстраивания долгосрочного и эффективного сотрудничества с предприятиями радиоэлектронной промышленности, предприятиями ВПК и научно-исследовательскими институтами России.

С нами вы становитесь еще успешнее!

Наши контакты:

Телефон: +7 812 627 14 35

Электронная почта: sales@st-electron.ru

Адрес: 198099, Санкт-Петербург,
Промышленная ул, дом № 19, литера Н,
помещение 100-Н Офис 331