



Is Now Part of



ON Semiconductor®

To learn more about ON Semiconductor, please visit our website at
www.onsemi.com

Please note: As part of the Fairchild Semiconductor integration, some of the Fairchild orderable part numbers will need to change in order to meet ON Semiconductor's system requirements. Since the ON Semiconductor product management systems do not have the ability to manage part nomenclature that utilizes an underscore (_), the underscore (_) in the Fairchild part numbers will be changed to a dash (-). This document may contain device numbers with an underscore (_). Please check the ON Semiconductor website to verify the updated device numbers. The most current and up-to-date ordering information can be found at www.onsemi.com. Please email any questions regarding the system integration to Fairchild_questions@onsemi.com.

ON Semiconductor and the ON Semiconductor logo are trademarks of Semiconductor Components Industries, LLC dba ON Semiconductor or its subsidiaries in the United States and/or other countries. ON Semiconductor owns the rights to a number of patents, trademarks, copyrights, trade secrets, and other intellectual property. A listing of ON Semiconductor's product/patent coverage may be accessed at www.onsemi.com/site/pdf/Patent-Marking.pdf. ON Semiconductor reserves the right to make changes without further notice to any products herein. ON Semiconductor makes no warranty, representation or guarantee regarding the suitability of its products for any particular purpose, nor does ON Semiconductor assume any liability arising out of the application or use of any product or circuit, and specifically disclaims any and all liability, including without limitation special, consequential or incidental damages. Buyer is responsible for its products and applications using ON Semiconductor products, including compliance with all laws, regulations and safety requirements or standards, regardless of any support or applications information provided by ON Semiconductor. "Typical" parameters which may be provided in ON Semiconductor data sheets and/or specifications can and do vary in different applications and actual performance may vary over time. All operating parameters, including "Typicals" must be validated for each customer application by customer's technical experts. ON Semiconductor does not convey any license under its patent rights nor the rights of others. ON Semiconductor products are not designed, intended, or authorized for use as a critical component in life support systems or any FDA Class 3 medical devices or medical devices with a same or similar classification in a foreign jurisdiction or any devices intended for implantation in the human body. Should Buyer purchase or use ON Semiconductor products for any such unintended or unauthorized application, Buyer shall indemnify and hold ON Semiconductor and its officers, employees, subsidiaries, affiliates, and distributors harmless against all claims, costs, damages, and expenses, and reasonable attorney fees arising out of, directly or indirectly, any claim of personal injury or death associated with such unintended or unauthorized use, even if such claim alleges that ON Semiconductor was negligent regarding the design or manufacture of the part. ON Semiconductor is an Equal Opportunity/Affirmative Action Employer. This literature is subject to all applicable copyright laws and is not for resale in any manner.

FSAM50SM60A

Motion SPM® 2 Series

Features

- UL Certified No. E209204 (UL1557)
- 600 V - 50 A 3-Phase IGBT Inverter with Integral Gate Drivers and Protection
- Low-Loss, Short-Circuit Rated IGBTs
- Very Low Thermal Resistance Using Al₂O₃ DBC Substrate
- Separate Open-Emitter Pins from Low Side IGBTs for Three-Phase Current Sensing
- Single-Grounded Power Supply
- Optimized for 5 kHz Switching Frequency
- Built-in NTC Thermistor for Temperature Monitoring
- Inverter Power Rating of 4.0 kW / 100~253 VAC
- Adjustable Current Protection Level via Selection of Sense-IGBT Emitter's External Rs
- Isolation Rating: 2500 V_{rms} / min.

Applications

- Motion Control - Home Appliance / Industrial Motor

Resource

- [AN-9043 - Motion SPM® 2 Series User's Guide](#)

General Description

FSAM50SM60A is a Motion SPM® 2 module providing a fully-featured, high-performance inverter stage for AC Induction, BLDC, and PMSM motors. These modules integrate optimized gate drive of the built-in IGBTs to minimize EMI and losses, while also providing multiple on-module protection features including under-voltage lockouts, over-current shutdown, thermal monitoring, and fault reporting. The built-in, high-speed HVIC requires only a single supply voltage and translates the incoming logic-level gate inputs to the high-voltage, high-current drive signals required to properly drive the module's internal IGBTs. Separate negative IGBT terminals are available for each phase to support the widest variety of control algorithms.

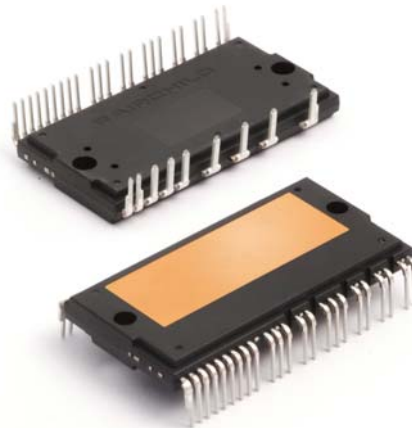

Figure 1. Package Overview

Package Marking and Ordering Information

Device	Device Marking	Package	Packing Type	Quantity
FSAM50SM60A	FSAM50SM60A	S32CA-032	Rail	8

Integrated Power Functions

- 600V - 50 A IGBT inverter for three-phase DC / AC power conversion (please refer to Figure 3)

Integrated Drive, Protection and System Control Functions

- For inverter high-side IGBTs: gate drive circuit, high-voltage isolated high-speed level shifting control circuit Under-Voltage Lock-Out (UVLO) Protection
 Note) Available bootstrap circuit example is given in Figures 13 and 14.
- For inverter low-side IGBTs: gate drive circuit, Short-Circuit Protection (SCP) control supply circuit Under-Voltage Lock-Out (UVLO) Protection
- Temperature Monitoring: system temperature monitoring using built-in thermistor
 Note) Available temperature monitoring circuit is given in Figure 14.
- Fault signaling: corresponding to a SC fault (low-side IGBTs) and UV fault (low-side control supply)
- Input interface: active-LOW Interface, works with 3.3 / 5 V logic, Schmitt-trigger input

Pin Configuration

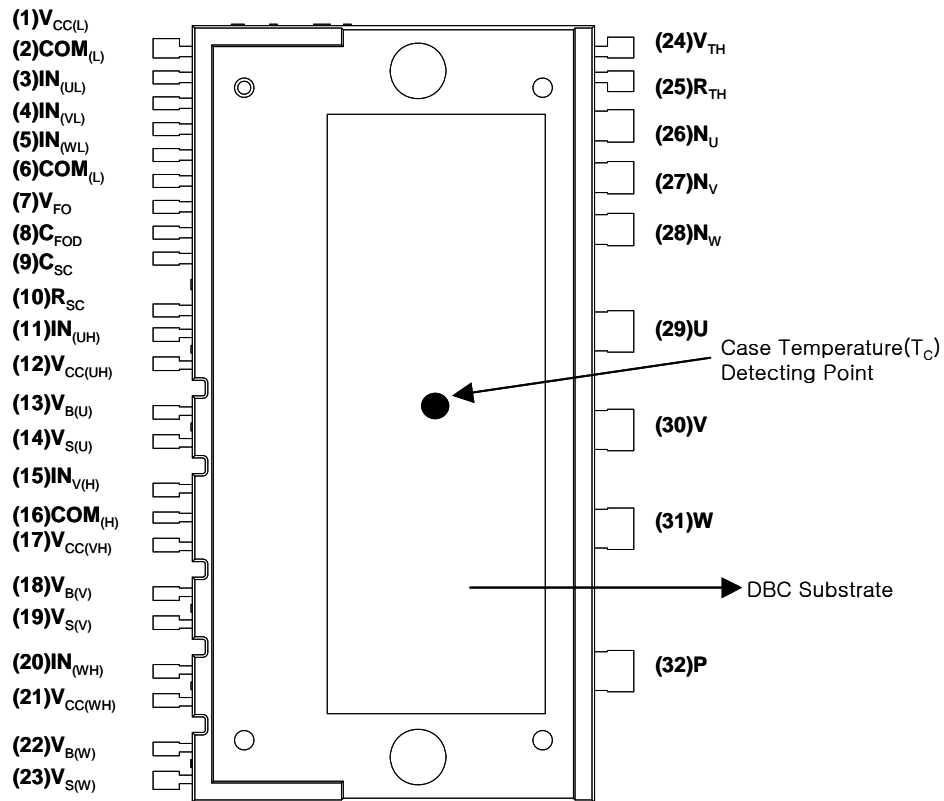

Figure 2. Top View

Pin Descriptions

Pin Number	Pin Name	Pin Description
1	$V_{CC(L)}$	Low-Side Common Bias Voltage for IC and IGBTs Driving
2	$COM_{(L)}$	Low-Side Common Supply Ground
3	$IN_{(UL)}$	Signal Input Terminal for Low-Side U-Phase
4	$IN_{(VL)}$	Signal Input Terminal for Low-Side V-Phase
5	$IN_{(WL)}$	Signal Input Terminal for Low-Side W-Phase
6	$COM_{(L)}$	Low-Side Common Supply Ground
7	V_{FO}	Fault Output
8	C_{FOD}	Capacitor for Fault Output Duration Selection
9	C_{SC}	Capacitor (Low-Pass Filter) for Short-Circuit Current Detection Input
10	R_{SC}	Resistor for Short-Circuit Current Detection
11	$IN_{(UH)}$	Signal Input for High-Side U-Phase
12	$V_{CC(UH)}$	High-Side Bias Voltage for U-Phase IC
13	$V_{B(U)}$	High-Side Bias Voltage for U-Phase IGBT Driving
14	$V_{S(U)}$	High-Side Bias Voltage Ground for U-Phase IGBT Driving
15	$IN_{(VH)}$	Signal Input for High-Side V-Phase
16	$COM_{(H)}$	High-Side Common Supply Ground
17	$V_{CC(VH)}$	High-Side Bias Voltage for V-Phase IC
18	$V_{B(V)}$	High-Side Bias Voltage for V-Phase IGBT Driving
19	$V_{S(V)}$	High-Side Bias Voltage Ground for V-Phase IGBT Driving
20	$IN_{(WH)}$	Signal Input for High-side W-Phase
21	$V_{CC(WH)}$	High-Side Bias Voltage for W-Phase IC
22	$V_{B(W)}$	High-Side Bias Voltage for W-Phase IGBT Driving
23	$V_{S(W)}$	High-Side Bias Voltage Ground for W-Phase IGBT Driving
24	V_{TH}	Thermistor Bias Voltage
25	R_{TH}	Series Resistor for the Use of Thermistor (Temperature Detection)
26	N_U	Negative DC-Link Input Terminal for U-Phase
27	N_V	Negative DC-Link Input Terminal for V-Phase
28	N_W	Negative DC-Link Input Terminal for W-Phase
29	U	Output for U-Phase
30	V	Output for V-Phase
31	W	Output for W-Phase
32	P	Positive DC-Link Input

Internal Equivalent Circuit and Input/Output Pins

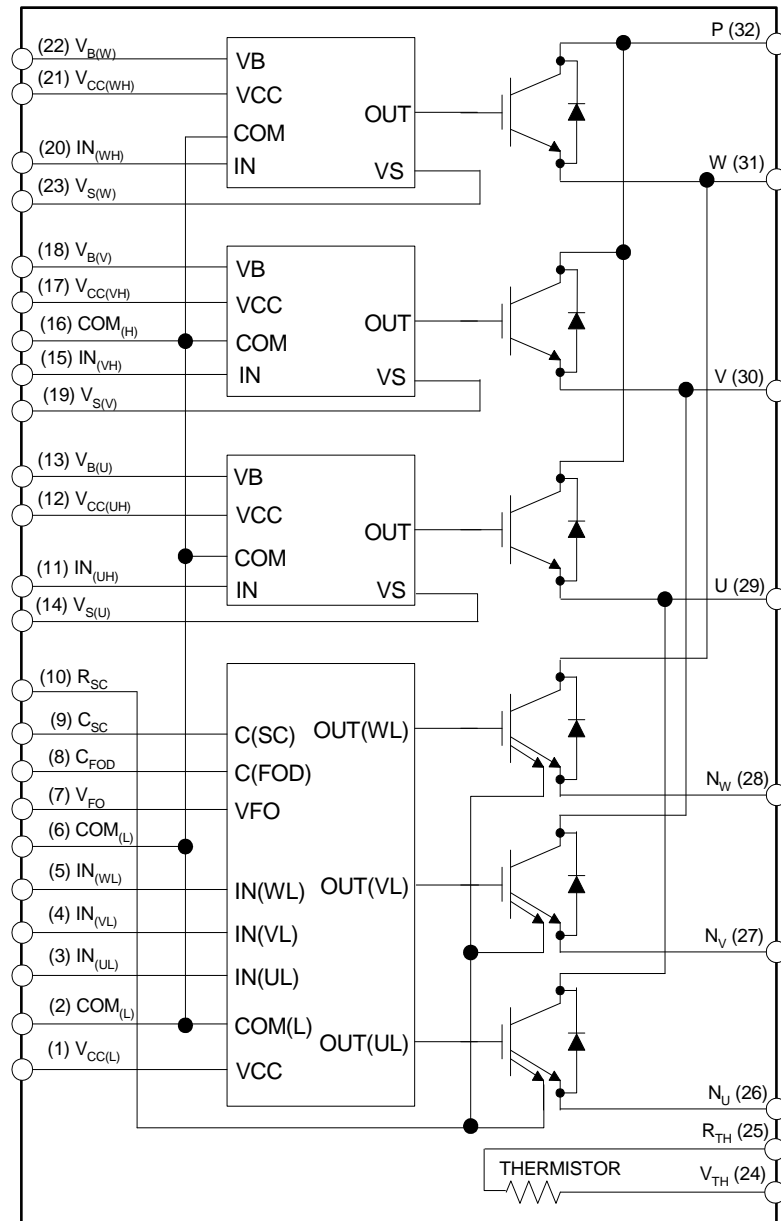

Figure 3. Internal Block Diagram

1st Notes:

1. Inverter low-side is composed of three sense-IGBTs including freewheeling diodes for each IGBT and one control IC which has gate driving, current-sensing and protection functions.
2. Inverter power side is composed of four inverter DC-link input pins and three inverter output pins.
3. Inverter high-side is composed of three normal-IGBTs including freewheeling diodes and three drive ICs for each IGBT.

Absolute Maximum Ratings (T_J = 25°C, unless otherwise specified.)

Inverter Part

Item	Symbol	Condition	Rating	Unit
Supply Voltage	V _{DC}	Applied to DC-Link	450	V
Supply Voltage (Surge)	V _{PN(Surge)}	Applied between P and N	500	V
Collector - Emitter Voltage	V _{CES}		600	V
Each IGBT Collector Current	± I _C	T _C = 25°C	50	A
Each IGBT Collector Current	± I _C	T _C = 100°C	25	A
Each IGBT Collector Current (Peak)	± I _{CP}	T _C = 25°C, Under 1ms Pulse Width	100	A
Collector Dissipation	P _C	T _C = 25°C per Chip	100	W
Operating Junction Temperature	T _J	(2nd Note 1)	-20 ~ 125	°C

2nd Notes:

1. It would be recommended that the average junction temperature should be limited to T_J ≤ 125°C (at T_C ≤ 100°C) in order to guarantee safe operation.

Control Part

Item	Symbol	Condition	Rating	Unit
Control Supply Voltage	V _{CC}	Applied between V _{CC(UH)} , V _{CC(VH)} , V _{CC(WH)} - COM _(H) , V _{CC(L)} - COM _(L)	20	V
High-Side Control Bias Voltage	V _{BS}	Applied between V _{B(U)} - V _{S(U)} , V _{B(V)} - V _{S(V)} , V _{B(W)} - V _{S(W)}	20	V
Input Signal Voltage	V _{IN}	Applied between IN _(UH) , IN _(VH) , IN _(WH) - COM _(H) , IN _(UL) , IN _(VL) , IN _(WL) - COM _(L)	-0.3 ~ V _{CC} +0.3	V
Fault Output Supply Voltage	V _{FO}	Applied between V _{FO} - COM _(L)	-0.3 ~ V _{CC} +0.3	V
Fault Output Current	I _{FO}	Sink Current at V _{FO} Pin	5	mA
Current-Sensing Input Voltage	V _{SC}	Applied between C _{SC} - COM _(L)	-0.3 ~ V _{CC} +0.3	V

Total System

Item	Symbol	Condition	Rating	Unit
Self-Protection Supply Voltage Limit (Short-Circuit Protection Capability)	V _{PN(PROT)}	Applied to DC-Link, V _{CC} = V _{BS} = 13.5 ~ 16.5 V, T _J = 125°C, Non-Repetitive, < 5 μs	400	V
Module Case Operation Temperature	T _C	See Figure 2	-20 ~ 100	°C
Storage Temperature	T _{STG}		-20 ~ 125	°C
Isolation Voltage	V _{ISO}	60Hz, Sinusoidal, AC 1 Minute, Connect Pins to Heat Sink Plate	2500	V _{rms}

Thermal Resistance

Item	Symbol	Condition	Min.	Typ.	Max.	Unit
Junction to Case Thermal Resistance	R _{th(j-c)Q}	Inverter IGBT Part (per 1/6 module)	-	-	1.00	°C/W
	R _{th(j-c)F}	Inverter FWDi Part (per 1/6 module)	-	-	1.50	°C/W
Contact Thermal Resistance	R _{th(c-f)}	DBC Substrate (per 1 Module) Thermal Grease Applied (2nd Note 3)	-	-	0.06	°C/W

2nd Notes:

2. For the measurement point of case temperature(T_C), please refer to Figure 2.
3. The thickness of thermal grease should not be more than 100 μm.

Electrical Characteristics

Inverter Part ($T_J = 25^\circ\text{C}$, unless otherwise specified.)

Item	Symbol	Condition	Min.	Typ.	Max.	Unit
Collector - emitter Saturation Voltage	$V_{CE(SAT)}$	$V_{CC} = V_{BS} = 15\text{ V}$ $V_{IN} = 0\text{ V}$	-	-	2.4	V
FWDi Forward Voltage	V_{FM}	$V_{IN} = 5\text{ V}$	-	-	2.1	V
Switching Times	t_{ON}	$V_{PN} = 300\text{ V}, V_{CC} = V_{BS} = 15\text{ V}$ $I_C = 50\text{ A}, T_J = 25^\circ\text{C}$ $V_{IN} = 5\text{ V} \leftrightarrow 0\text{ V}$, Inductive Load (High- And Low-Side)	-	0.69	-	μs
	$t_{C(ON)}$		-	0.32	-	μs
	t_{OFF}		-	1.32	-	μs
	$t_{C(OFF)}$		-	0.46	-	μs
	t_{rr}		(2nd Note 4)	-	0.10	-
Collector-Emitter Leakage Current	I_{CES}	$V_{CE} = V_{CES}, T_J = 25^\circ\text{C}$	-	-	250	μA

2nd Notes:

4. t_{ON} and t_{OFF} include the propagation delay time of the internal drive IC. $t_{C(ON)}$ and $t_{C(OFF)}$ are the switching time of IGBT itself under the given gate driving condition internally. For the detailed information, please see Figure 4.

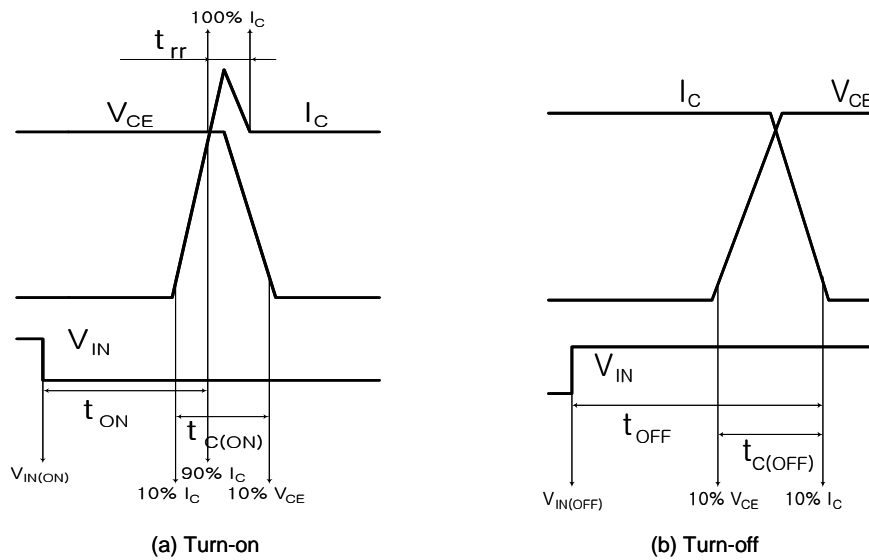

Figure 4. Switching Time Definition

Electrical Characteristics (T_J = 25°C, unless otherwise specified.)

Control Part

Item	Symbol	Condition	Min.	Typ.	Max.	Unit		
Quiescent V _{CC} Supply Current	I _{QCCL}	V _{CC} = 15 V I _{N(UL, VL, WL)} = 5V	V _{CC(L)} - COM _(L)	-	-	26	mA	
	I _{QCCH}	V _{CC} = 15 V I _{N(UH, VH, WH)} = 5V	V _{CC(UH)} , V _{CC(VH)} , V _{CC(WH)} - COM _(H)	-	-	130	μA	
Quiescent V _{BS} Supply Current	I _{QBS}	V _{BS} = 15 V I _{N(UH, VH, WH)} = 5V	V _{B(U)} - V _{S(U)} , V _{B(V)} - V _{S(V)} , V _{B(W)} - V _{S(W)}	-	-	420	μA	
Fault Output Voltage	V _{FOH}	V _{SC} = 0 V, V _{FO} Circuit: 4.7 kΩ to 5 V Pull-up	4.5	-	-	V		
	V _{FOL}	V _{SC} = 1 V, V _{FO} Circuit: 4.7 kΩ to 5 V Pull-up	-	-	1.1	V		
Short-Circuit Trip Level	V _{SC(ref)}	V _{CC} = 15 V (2nd Note 5)	0.45	0.51	0.56	V		
Sensing Voltage of IGBT Current	V _{SEN}	R _{SC} = 40 Ω, R _{SU} = R _{SV} = R _{SW} = 0 Ω and I _C = 75 A (See a Figure 6)	0.45	0.51	0.56	V		
Supply Circuit Under-Voltage Protection	UV _{CCD}	Detection Level	11.5	12.0	12.5	V		
	UV _{CCR}	Reset Level	12.0	12.5	13.0	V		
	UV _{BSD}	Detection Level	7.3	9.0	10.8	V		
	UV _{BSR}	Reset Level	8.6	10.3	12.0	V		
Fault Output Pulse Width	t _{FOD}	C _{FOD} = 33 nF (2nd Note 6)	1.4	1.8	2.0	ms		
ON Threshold Voltage	V _{IN(ON)}	High-Side	Applied between I _{N(UH)} , I _{N(VH)} , I _{N(WH)} - COM _(H)		-	-	0.8	V
OFF Threshold Voltage	V _{IN(OFF)}		3.0	-	-	V		
ON Threshold Voltage	V _{IN(ON)}	Low-Side	Applied between I _{N(UL)} , I _{N(VL)} , I _{N(WL)} - COM _(L)		-	-	0.8	V
OFF Threshold Voltage	V _{IN(OFF)}		3.0	-	-	V		
Resistance of Thermistor	R _{TH}	@ T _{TH} = 25°C (2nd Note 7, Figure 5)	-	50	-	kΩ		
		@ T _{TH} = 100°C (2nd Note 7, Figure 5)	-	3.0	-	kΩ		

2nd Notes:

- Short-circuit protection is functioning only at the low-sides. It would be recommended that the value of the external sensing resistor (R_{SC}) should be selected around 40 Ω in order to make the SC trip-level of about 75A. at the shunt resistors (R_{SU}, R_{SV}, R_{SW}) of 0 Ω. For the detailed information about the relationship between the external sensing resistor (R_{SC}) and the shunt resistors (R_{SU}, R_{SV}, R_{SW}), please see Figure 6.
- The fault-out pulse width t_{FOD} depends on the capacitance value of C_{FOD} according to the following approximate equation: C_{FOD} = 18.3 × 10⁻⁶ × t_{FOD} [F]
- T_{TH} is the temperature of thermistor itself. To know case temperature (T_C), please make the experiment considering your application.



Figure 5. R-T Curve of The Built-in Thermistor

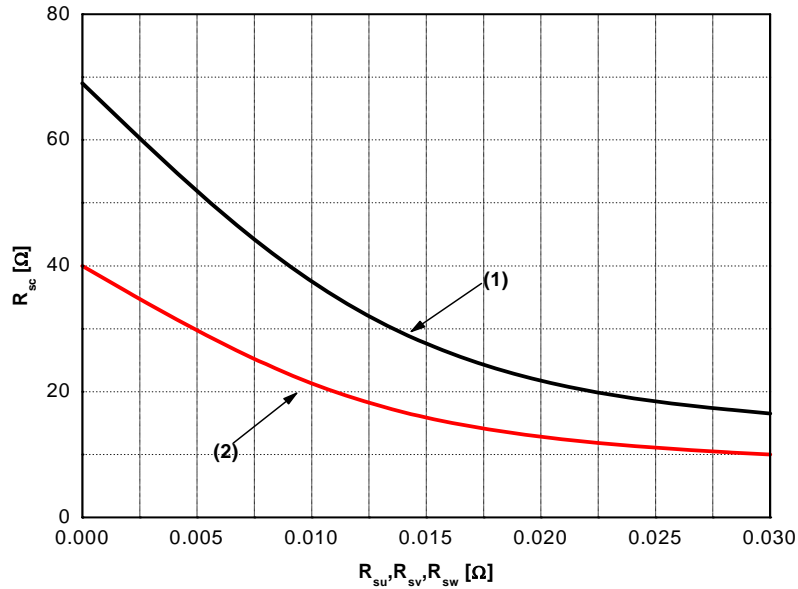

Figure 6. R_{SC} Variation by Change of Shunt Resistors (R_{SU}, R_{SV}, R_{SW}) for Short-Circuit Protection
 (1) @ Current Trip Level ≅ 50 A
 (2) @ Current Trip Level ≅ 75 A

Recommended Operating Conditions

Item	Symbol	Condition	Min.	Typ.	Max.	Unit
Supply Voltage	V _{PN}	Applied between P - N _U , N _V , N _W	-	300	400	V
Control Supply Voltage	V _{CC}	Applied between V _{CC(UH)} , V _{CC(VH)} , V _{CC(WH)} - COM _(H) , V _{CC(L)} - COM _(L)	13.5	15.0	16.5	V
High-side Bias Voltage	V _{BS}	Applied between V _{B(U)} - V _{S(U)} , V _{B(V)} - V _{S(V)} , V _{B(W)} - V _{S(W)}	13.0	15.0	18.5	V
Blanking Time for Preventing Arm-short	t _{dead}	For Each Input Signal	3.5	-	-	μs
PWM Input Signal	f _{PWM}	T _C ≤ 100°C, T _J ≤ 125°C	-	5	-	kHz
Minimum Input Pulse Width	PW _{IN(OFF)}	200 ≤ V _{PN} ≤ 400 V, 13.5 ≤ V _{CC} ≤ 16.5 V, 13.0 ≤ V _{BS} ≤ 18.5 V, 0 ≤ I _C ≤ 100 A, -20 ≤ T _J ≤ 125°C V _{IN} = 5 V ↔ 0 V, Inductive Load (2nd Note 8)	3	-	-	μs
Input ON Threshold Voltage	V _{IN(ON)}	Applied between IN _(UH) , IN _(VH) , IN _(WH) - COM _(H) , IN _(UL) , IN _(VL) , IN _(WL) - COM _(L)	0 ~ 0.65			V
Input OFF Threshold Voltage	V _{IN(OFF)}	Applied between IN _(UH) , IN _(VH) , IN _(WH) - COM _(H) , IN _(UL) , IN _(VL) , IN _(WL) - COM _(L)	4 ~ 5.5			V

2nd Notes:

8. Motion SPM® 2 product might not make response if the PW_{IN(OFF)} is less than the recommended minimum value.

Mechanical Characteristics and Ratings

Item	Condition		Min.	Typ.	Max.	Units
Mounting Torque	Mounting Screw: M4 (2nd Note 9 and 10)	Recommended 10 kg•cm	8	10	12	kg•cm
		Recommended 0.98 N•m	0.78	0.98	1.17	N•m
DBC Flatness		See Figure 7	0	-	+120	μm
Weight			-	32	-	g

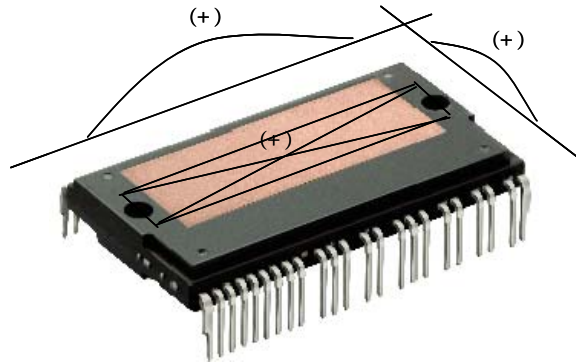

Figure 7. Flatness Measurement Position of The DBC Substrate

2nd Notes:

- 9. Do not make over torque or mounting screws. Much mounting torque may cause DBC substrate cracks and bolts and Al heat-sink destruction.
- 10. Avoid one side tightening stress. Figure 8 shows the recommended torque order for mounting screws. Uneven mounting can cause the Motion SPM® 2 package DBC substrate to be damaged.



Figure 8. Mounting Screws Torque Order (1 → 2)

Time Charts of Protective Function

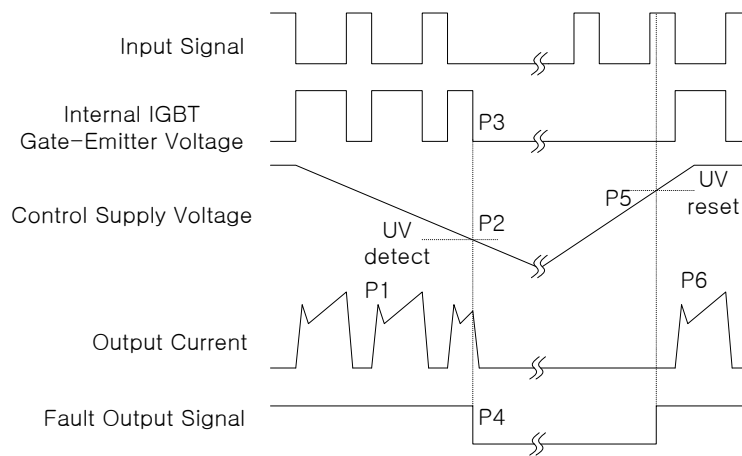

- P1 : Normal operation: IGBT ON and conducting current .
- P2 : Under-voltage detection.
- P3 : IGBT gate interrupt.
- P4 : Fault signal generation.
- P5 : Under-voltage reset.
- P6 : Normal operation: IGBT ON and conducting current.

Figure 9. Under-Voltage Protection (Low-Side)

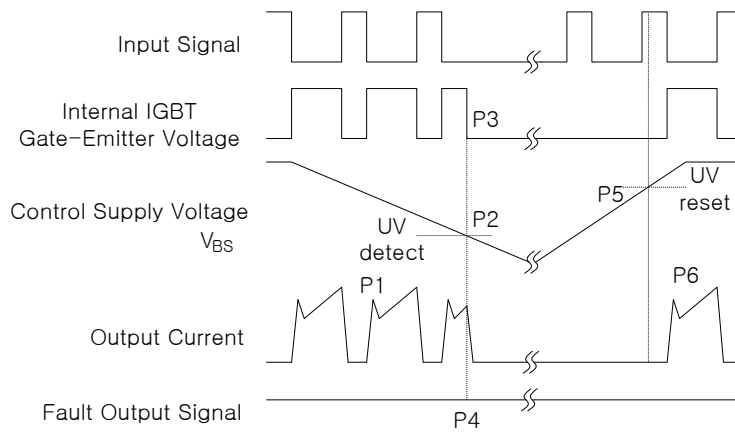

- P1 : Normal operation: IGBT ON and conducting current.
- P2 : Under-voltage detection.
- P3 : IGBT gate interrupt.
- P4 : No fault signal.
- P5 : Under-voltage reset.
- P6 : Normal operation: IGBT ON and conducting current.

Figure 10. Under-Voltage Protection (High-Side)

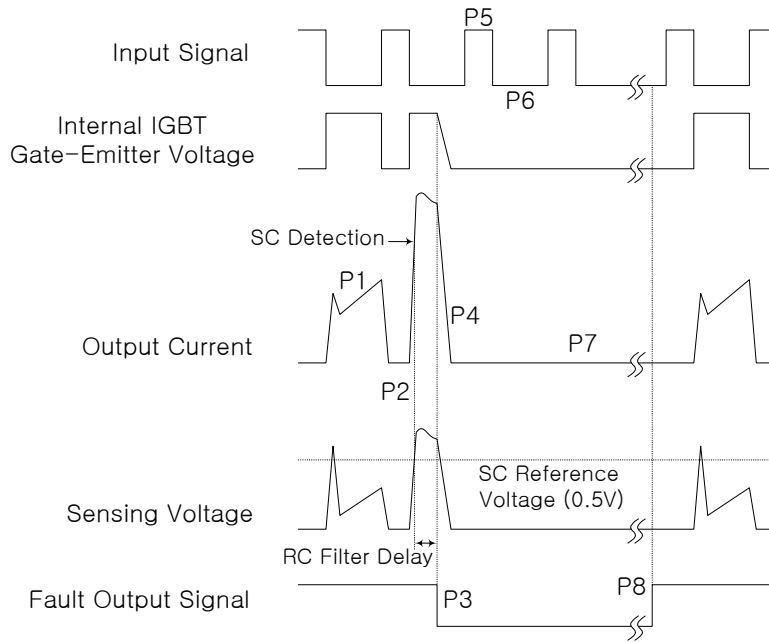

- P1 : Normal operation: IGBT ON and conducting current.
- P2 : Short-circuit current detection.
- P3 : IGBT gate interrupt / fault signal generation.
- P4 : IGBT is slowly turned off.
- P5 : IGBT OFF signal.
- P6 : IGBT ON signal: but IGBT cannot be turned on during the fault-output activation.
- P7 : IGBT OFF state.
- P8 : Fault-output reset and normal operation start.

Figure 11. Short-Circuit Protection (Low-Side Operation Only)



Figure 12. Recommended MCU I/O Interface Circuit

3rd Notes:

1. It would be recommended that by-pass capacitors for the gating input signals, $IN_{(UL)}$, $IN_{(VL)}$, $IN_{(WL)}$, $IN_{(UH)}$, $IN_{(VH)}$ and $IN_{(WH)}$ should be placed on the Motion SPM® 2 product pins and on the both sides of MCU and Motion SPM 2 Product for the fault output signal, V_{FO} , as close as possible.
2. The logic input works with standard CMOS or LSTTL outputs.
3. $R_{PL}C_{PL}/R_{PH}C_{PH}/R_{PF}C_{PF}$ coupling at each Motion SPM 2 product input is recommended in order to prevent input/output signals' oscillation and it should be as close as possible to each of Motion SPM 2 Product pins.

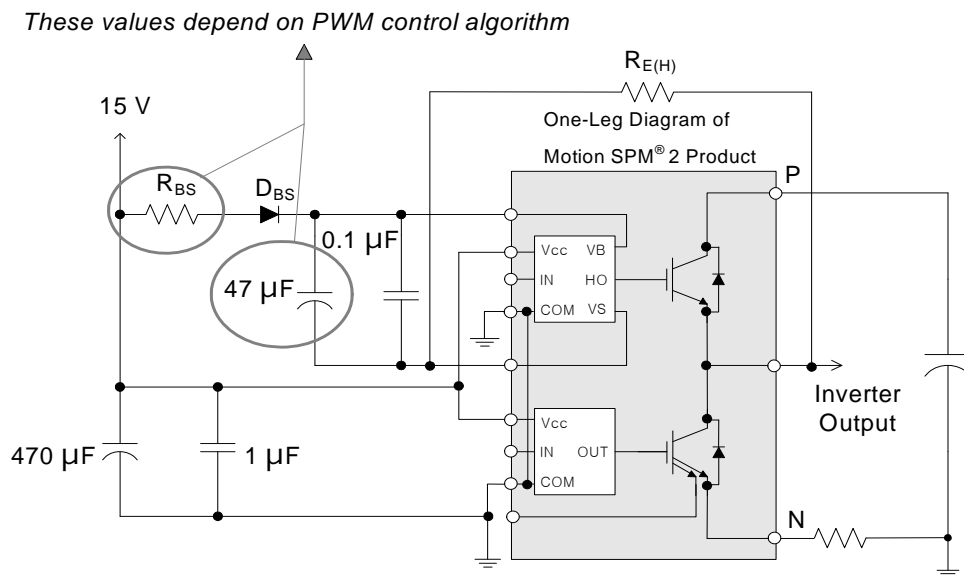

Figure 13. Recommended Bootstrap Operation Circuit and Parameters

3rd Notes:

4. It would be recommended that the bootstrap diode, D_{BS} , has soft and fast recovery characteristics.
5. The bootstrap resistor (R_{BS}) should be three times greater than $R_{E(H)}$. The recommended value of $R_{E(H)}$ is 5.6 Ω , but it can be increased up to 20 Ω for a slower dv/dt of high-side.
6. The ceramic capacitor placed between V_{CC} - COM should be over 1 μF and mounted as close to the pins of the Motion SPM® 2 product as possible.

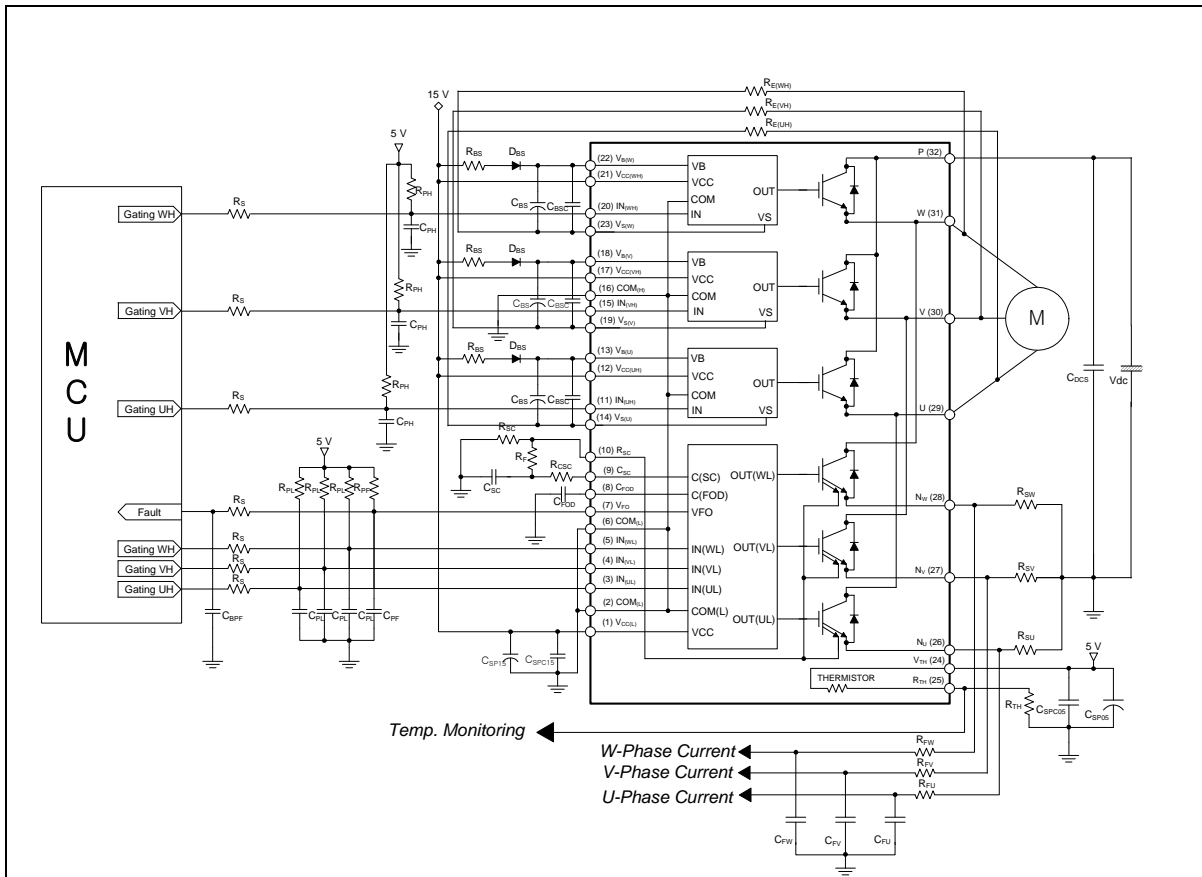
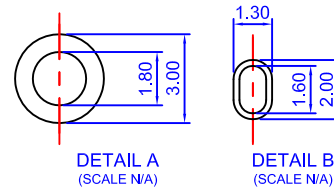
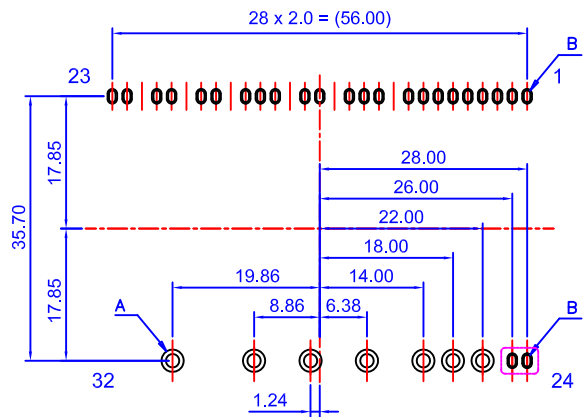
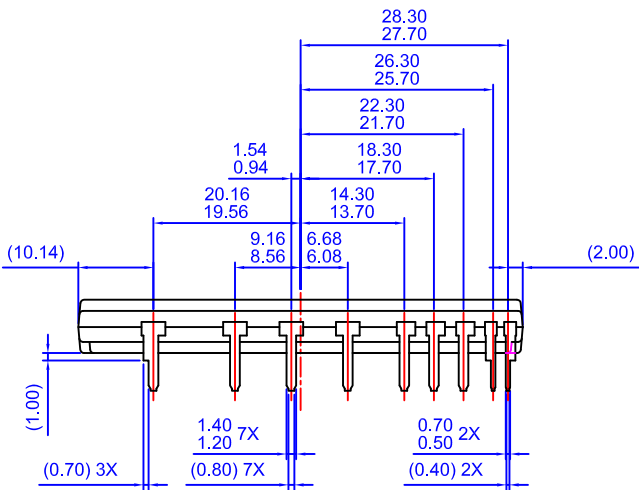
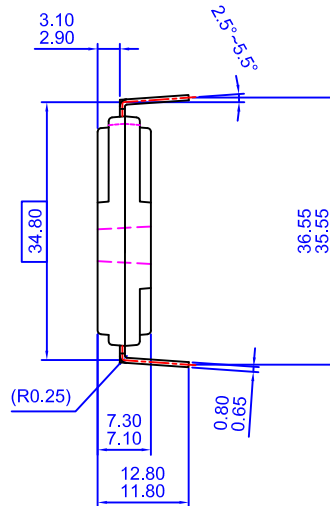
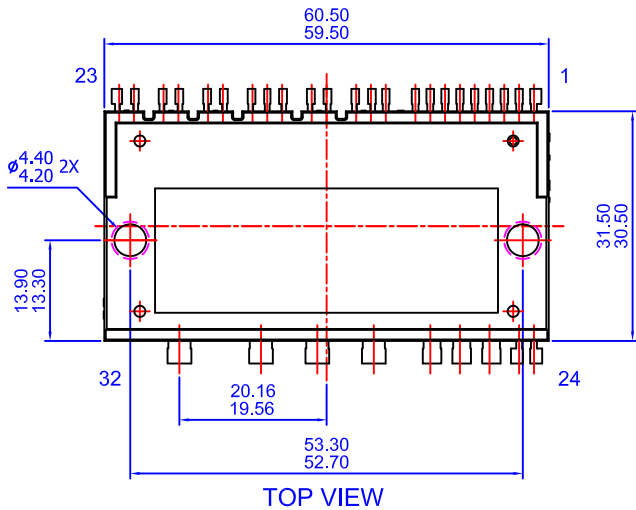
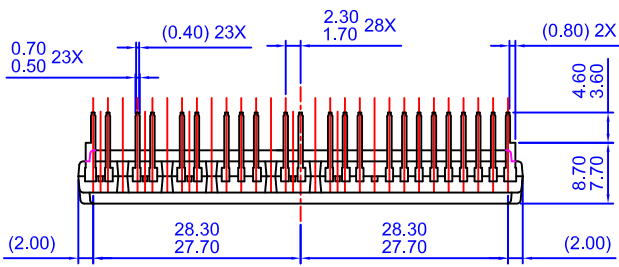

Figure 14. Application Circuit

4th Notes:

1. $R_{PI}C_{PI}/R_{PH}C_{PH}/R_{PF}C_{PF}$ coupling at each Motion SPM® 2 product input is recommended in order to prevent input signals' oscillation and it should be as close as possible to each Motion SPM 2 product input pin.
2. By virtue of integrating an application specific type HVIC inside the Motion SPM 2 product, direct coupling to MCU terminals without any optocoupler or transformer isolation is possible.
3. V_{FO} output is open-collector type. This signal line should be pulled up to the positive side of the 5 V power supply with approximately 4.7 kΩ resistance. Please refer to Figure 12.
4. C_{SP15} of around seven times larger than bootstrap capacitor C_{BS} is recommended.
5. V_{FO} output pulse width should be determined by connecting an external capacitor (C_{FOD}) between C_{FOD} (pin 8) and $COM_{(L)}$ (pin 2). (Example : if $C_{FOD} = 33$ nF, then $t_{FO} = 1.8$ ms (typ.)) Please refer to the 2nd note 6 for calculation method.
6. Each input signal line should be pulled up to the 5 V power supply with approximately 4.7 kΩ (at high side input) or 2 kΩ (at low side input) resistance (other RC coupling circuits at each input may be needed depending on the PWM control scheme used and on the wiring impedance of the system's printed circuit board). Approximately a 0.22 ~ 2 nF by-pass capacitor should be used across each power supply connection terminals.
7. To prevent errors of the protection function, the wiring around R_{SC} , R_F and C_{SC} should be as short as possible.
8. In the short-circuit protection circuit, please select the $R_F C_{SC}$ time constant in the range 3 ~ 4 μs.
9. Each capacitor should be mounted as close to the pins of the Motion SPM 2 product as possible.
10. To prevent surge destruction, the wiring between the smoothing capacitor and the P & N pins should be as short as possible. The use of a high frequency non-inductive capacitor of around 0.1 ~ 0.22 μF between the P&N pins is recommended.
11. Relays are used at almost every systems of electrical equipments of home appliances. In these cases, there should be sufficient distance between the MCU and the relays. It is recommended that the distance be 5 cm at least.



- NOTES:** UNLESS OTHERWISE SPECIFIED
- A) THIS PACKAGE DOES NOT COMPLY TO ANY CURRENT PACKAGING STANDARD
 - B) ALL DIMENSIONS ARE IN MILLIMETERS
 - C) DIMENSIONS ARE EXCLUSIVE OF BURRS, MOLD FLASH, AND TIE BAR EXTRUSIONS
 - D) () IS REFERENCE
 - E) DRAWING FILENAME: MOD32BAREV3

LAND PATTERN RECOMMENDATIONS



ON Semiconductor and  are trademarks of Semiconductor Components Industries, LLC dba ON Semiconductor or its subsidiaries in the United States and/or other countries. ON Semiconductor owns the rights to a number of patents, trademarks, copyrights, trade secrets, and other intellectual property. A listing of ON Semiconductor's product/patent coverage may be accessed at www.onsemi.com/site/pdf/Patent-Marking.pdf. ON Semiconductor reserves the right to make changes without further notice to any products herein. ON Semiconductor makes no warranty, representation or guarantee regarding the suitability of its products for any particular purpose, nor does ON Semiconductor assume any liability arising out of the application or use of any product or circuit, and specifically disclaims any and all liability, including without limitation special, consequential or incidental damages. Buyer is responsible for its products and applications using ON Semiconductor products, including compliance with all laws, regulations and safety requirements or standards, regardless of any support or applications information provided by ON Semiconductor. "Typical" parameters which may be provided in ON Semiconductor data sheets and/or specifications can and do vary in different applications and actual performance may vary over time. All operating parameters, including "Typicals" must be validated for each customer application by customer's technical experts. ON Semiconductor does not convey any license under its patent rights nor the rights of others. ON Semiconductor products are not designed, intended, or authorized for use as a critical component in life support systems or any FDA Class 3 medical devices or medical devices with a same or similar classification in a foreign jurisdiction or any devices intended for implantation in the human body. Should Buyer purchase or use ON Semiconductor products for any such unintended or unauthorized application, Buyer shall indemnify and hold ON Semiconductor and its officers, employees, subsidiaries, affiliates, and distributors harmless against all claims, costs, damages, and expenses, and reasonable attorney fees arising out of, directly or indirectly, any claim of personal injury or death associated with such unintended or unauthorized use, even if such claim alleges that ON Semiconductor was negligent regarding the design or manufacture of the part. ON Semiconductor is an Equal Opportunity/Affirmative Action Employer. This literature is subject to all applicable copyright laws and is not for resale in any manner.

PUBLICATION ORDERING INFORMATION

LITERATURE FULFILLMENT:

Literature Distribution Center for ON Semiconductor
19521 E. 32nd Pkwy, Aurora, Colorado 80011 USA
Phone: 303-675-2175 or 800-344-3860 Toll Free USA/Canada
Fax: 303-675-2176 or 800-344-3867 Toll Free USA/Canada
Email: orderlit@onsemi.com

N. American Technical Support: 800-282-9855 Toll Free
USA/Canada
Europe, Middle East and Africa Technical Support:
Phone: 421 33 790 2910
Japan Customer Focus Center
Phone: 81-3-5817-1050

ON Semiconductor Website: www.onsemi.com
Order Literature: <http://www.onsemi.com/orderlit>
For additional information, please contact your local
Sales Representative

Mouser Electronics

Authorized Distributor

Click to View Pricing, Inventory, Delivery & Lifecycle Information:

[ON Semiconductor:](#)

[FSAM50SM60A](#)



Стандарт Электрон Связь

Мы молодая и активно развивающаяся компания в области поставок электронных компонентов. Мы поставляем электронные компоненты отечественного и импортного производства напрямую от производителей и с крупнейших складов мира.

Благодаря сотрудничеству с мировыми поставщиками мы осуществляем комплексные и плановые поставки широчайшего спектра электронных компонентов.

Собственная эффективная логистика и склад в обеспечивает надежную поставку продукции в точно указанные сроки по всей России.

Мы осуществляем техническую поддержку нашим клиентам и предпродажную проверку качества продукции. На все поставляемые продукты мы предоставляем гарантию .

Осуществляем поставки продукции под контролем ВП МО РФ на предприятия военно-промышленного комплекса России , а также работаем в рамках 275 ФЗ с открытием отдельных счетов в уполномоченном банке. Система менеджмента качества компании соответствует требованиям ГОСТ ISO 9001.

Минимальные сроки поставки, гибкие цены, неограниченный ассортимент и индивидуальный подход к клиентам являются основой для выстраивания долгосрочного и эффективного сотрудничества с предприятиями радиоэлектронной промышленности, предприятиями ВПК и научно-исследовательскими институтами России.

С нами вы становитесь еще успешнее!

Наши контакты:

Телефон: +7 812 627 14 35

Электронная почта: sales@st-electron.ru

Адрес: 198099, Санкт-Петербург,
Промышленная ул, дом № 19, литера Н,
помещение 100-Н Офис 331