



MCP401X/2X
Digital Potentiometer
Evaluation Board
User's Guide

Note the following details of the code protection feature on Microchip devices:

- Microchip products meet the specification contained in their particular Microchip Data Sheet.
- Microchip believes that its family of products is one of the most secure families of its kind on the market today, when used in the intended manner and under normal conditions.
- There are dishonest and possibly illegal methods used to breach the code protection feature. All of these methods, to our knowledge, require using the Microchip products in a manner outside the operating specifications contained in Microchip's Data Sheets. Most likely, the person doing so is engaged in theft of intellectual property.
- Microchip is willing to work with the customer who is concerned about the integrity of their code.
- Neither Microchip nor any other semiconductor manufacturer can guarantee the security of their code. Code protection does not mean that we are guaranteeing the product as "unbreakable."

Code protection is constantly evolving. We at Microchip are committed to continuously improving the code protection features of our products. Attempts to break Microchip's code protection feature may be a violation of the Digital Millennium Copyright Act. If such acts allow unauthorized access to your software or other copyrighted work, you may have a right to sue for relief under that Act.

Information contained in this publication regarding device applications and the like is provided only for your convenience and may be superseded by updates. It is your responsibility to ensure that your application meets with your specifications. MICROCHIP MAKES NO REPRESENTATIONS OR WARRANTIES OF ANY KIND WHETHER EXPRESS OR IMPLIED, WRITTEN OR ORAL, STATUTORY OR OTHERWISE, RELATED TO THE INFORMATION, INCLUDING BUT NOT LIMITED TO ITS CONDITION, QUALITY, PERFORMANCE, MERCHANTABILITY OR FITNESS FOR PURPOSE. Microchip disclaims all liability arising from this information and its use. Use of Microchip's products as critical components in life support systems is not authorized except with express written approval by Microchip. No licenses are conveyed, implicitly or otherwise, under any Microchip intellectual property rights.

Trademarks

The Microchip name and logo, the Microchip logo, Accuron, dsPIC, KEELOQ, microID, MPLAB, PIC, PICmicro, PICSTART, PRO MATE, PowerSmart, rfPIC, and SmartShunt are registered trademarks of Microchip Technology Incorporated in the U.S.A. and other countries.

AmpLab, FilterLab, Migratable Memory, MXDEV, MXLAB, PICMASTER, SEEVAL, SmartSensor and The Embedded Control Solutions Company are registered trademarks of Microchip Technology Incorporated in the U.S.A.

Analog-for-the-Digital Age, Application Maestro, dsPICDEM, dsPICDEM.net, dsPICworks, ECAN, ECONOMONITOR, FanSense, FlexROM, fuzzyLAB, In-Circuit Serial Programming, ICSP, ICEPIC, Linear Active Thermistor, MPASM, MPLIB, MPLINK, MPSIM, PICKit, PICDEM, PICDEM.net, PICLAB, PICtail, PowerCal, PowerInfo, PowerMate, PowerTool, rLAB, rfPICDEM, Select Mode, Smart Serial, SmartTel, Total Endurance and WiperLock are trademarks of Microchip Technology Incorporated in the U.S.A. and other countries.

SQTP is a service mark of Microchip Technology Incorporated in the U.S.A.

All other trademarks mentioned herein are property of their respective companies.

© 2005, Microchip Technology Incorporated, Printed in the U.S.A., All Rights Reserved.

 Printed on recycled paper.

**QUALITY MANAGEMENT SYSTEM
CERTIFIED BY DNV
== ISO/TS 16949:2002 ==**

Microchip received ISO/TS-16949:2002 quality system certification for its worldwide headquarters, design and wafer fabrication facilities in Chandler and Tempe, Arizona and Mountain View, California in October 2003. The Company's quality system processes and procedures are for its PICmicro® 8-bit MCUs, KEELOQ® code hopping devices, Serial EEPROMs, microperipherals, nonvolatile memory and analog products. In addition, Microchip's quality system for the design and manufacture of development systems is ISO 9001:2000 certified.

Table of Contents

Preface	1
Chapter 1. Product Overview	
1.1 Introduction	5
1.2 What is the MCP402X Digital Potentiometer Evaluation Board?	5
1.3 What the MCP402X Digital Potentiometer Evaluation Board Kit Includes	6
Chapter 2. Installation and Operation	
2.1 Introduction	7
2.2 PCB Description	7
2.3 Test and Operating Instructions	10
2.4 Firmware Description	17
Appendix A. Schematic and Layouts	
A.1 Introduction	19
A.2 Schematic	20
A.3 MCP402X Board Layout – Top Layer + Silk-screen	21
A.4 MCP402X Board Layout – Bottom Layer	21
A.5 MCP402X Board Layout – Top Silkscreen	22
A.6 MCP402X Board Layout – Bottom Layer + Silk-screen	22
Appendix B. Bill Of Materials (BOM)	
Appendix C. Using the BFMP Programmer to Power the Board	
C.1 Powering the Board Using the BFMP Programmer	25
Appendix D. Potential Programming Issue of the MCP402XEV	
D.1 Introduction	27
Appendix E. 00066_MCP402XEV.ASM Source Code	
E.1 Introduction	29
Worldwide Sales and Service	42

MCP401X/2X Evaluation Board User's Guide

NOTES:

Preface

NOTICE TO CUSTOMERS

All documentation becomes dated, and this manual is no exception. Microchip tools and documentation are constantly evolving to meet customer needs, so some actual dialogs and/or tool descriptions may differ from those in this document. Please refer to our web site (www.microchip.com) to obtain the latest documentation available.

Documents are identified with a “DS” number. This number is located on the bottom of each page, in front of the page number. The numbering convention for the DS number is “DSXXXXA”, where “XXXX” is the document number and “A” is the revision level of the document.

INTRODUCTION

This chapter contains general information that will be useful to know before using the MCP402X Digital Potentiometer Evaluation Board. Items discussed in this chapter include:

- Document Layout
- Conventions Used in this Guide
- Recommended Reading
- The Microchip Web Site
- Customer Support
- Document Revision History

DOCUMENT LAYOUT

This document describes how to use the MCP402X Digital Potentiometer Evaluation Board. The manual layout is as follows:

- **Chapter 1. “Product Overview”** – Important information about the MCP402X Digital Potentiometer Evaluation Board.
- **Chapter 2. “Installation and Operation”** – Includes instructions on how to get started with this evaluation board.
- **Appendix A. “Schematic and Layouts”** – Shows the schematic and layout diagrams for the MCP402X Digital Potentiometer Evaluation Board.
- **Appendix B. “Bill Of Materials (BOM)”** – Lists the parts used to build the MCP402X Digital Potentiometer Evaluation Board.
- **Appendix C. “Using the BFMP Programmer to Power the Board”** – Shows how to interface the BFMP board with the MCP402X Digital Potentiometer Evaluation Board.
- **Appendix D. “Potential Programming Issue of the MCP402XEV”** – Discusses possible programming issues with Rev 1 and Rev 2 of the MCP402X Digital Potentiometer Evaluation Board.
- **Appendix E. “00066_MCP402XEV.ASM Source Code”** – Provides information about the application firmware, as well as the location of the source code.

MCP401X/2X Evaluation Board User's Guide

CONVENTIONS USED IN THIS GUIDE

This manual uses the following documentation conventions:

DOCUMENTATION CONVENTIONS

Description	Represents	Examples
Arial font:		
Italic characters	Referenced books	<i>MPLAB[®] IDE User's Guide</i>
	Emphasized text	...is the <i>only</i> compiler...
Initial caps	A window	the Output window
	A dialog	the Settings dialog
	A menu selection	select Enable Programmer
Quotes	A field name in a window or dialog	"Save project before build"
Underlined, italic text with right angle bracket	A menu path	<u><i>File</i></u> >Save
Bold characters	A dialog button	Click OK
	A tab	Click the Power tab
'bnnnn'	A binary number where <i>n</i> is a digit	'b00100, 'b10
Text in angle brackets < >	A key on the keyboard	Press <Enter>, <F1>
Courier New font:		
Plain Courier New	Sample source code	#define START
	Filenames	autoexec.bat
	File paths	c:\mcc18\h
	Keywords	_asm, _endasm, static
	Command-line options	-Opa+, -Opa-
	Bit values	0, 1
Italic Courier New	A variable argument	<i>file.o</i> , where <i>file</i> can be any valid filename
0xnnnn	A hexadecimal number where <i>n</i> is a hexadecimal digit	0xFFFF, 0x007A
Square brackets []	Optional arguments	mcc18 [options] <i>file</i> [options]
Curly brackets and pipe character: { }	Choice of mutually exclusive arguments; an OR selection	errorlevel {0 1}
Ellipses...	Replaces repeated text	var_name [, var_name...]
	Represents code supplied by user	void main (void) { ... }

RECOMMENDED READING

This user's guide describes how to use the MCP402X Digital Potentiometer Evaluation Board. The following Microchip documents are available and recommended as supplemental reference resources.

MCP4011/2/3/4, "Low-Cost, 64-Step Volatile Digital POT in SOT-23" Data Sheet (DS21978).

MCP4021/2/3/4, "Low-Cost NV Digital POT in SOT-23 with WiperLock™ Technology" Data Sheet (DS21945).

PIC10F200/202/204/206, "6-Pin, 8-Bit Flash Microcontrollers" Data Sheet (DS41239)

THE MICROCHIP WEB SITE

Microchip provides online support via our web site at www.microchip.com. This web site is used as a means to make files and information easily available to customers. Accessible by using your favorite Internet browser, the web site contains the following information:

- **Product Support** – Data sheets and errata, application notes and sample programs, design resources, user's guides and hardware support documents, latest software releases and archived software
- **General Technical Support** – Frequently Asked Questions (FAQs), technical support requests, online discussion groups, Microchip consultant program member listing
- **Business of Microchip** – Product selector and ordering guides, latest Microchip press releases, listing of seminars and events, listings of Microchip sales offices, distributors and factory representatives

CUSTOMER SUPPORT

Users of Microchip products can receive assistance through several channels:

- Distributor or Representative
- Local Sales Office
- Field Application Engineer (FAE)
- Technical Support
- Development Systems Information Line

Customers should contact their distributor, representative or field application engineer (FAE) for support. Local sales offices are also available to help customers. A listing of sales offices and locations is included in the back of this document.

Technical support is available through the web site at: <http://support.microchip.com>

DOCUMENT REVISION HISTORY

Revision B (December 2005)

- Updated to include MCP401X devices
- Enhancement of Operation Description
- Added **Appendix C. "Using the BFMP Programmer to Power the Board"** - Programming the MCP402X Digital Potentiometer Evaluation Board
- Added **Appendix D. "Potential Programming Issue of the MCP402XEV"** - A description of potential programming issues (and their solutions) with the MCP402X Digital Potentiometer Evaluation Board

Revision A (April 2005)

- Initial Release of this Document

MCP401X/2X Evaluation Board User's Guide

NOTES:

Chapter 1. Product Overview

1.1 INTRODUCTION

This chapter provides an overview of the MCP402X Digital Potentiometer Evaluation Board and covers the following topics:

- What is the MCP402X Digital Potentiometer Evaluation Board?
- What the MCP402X Digital Potentiometer Evaluation Board includes

1.2 WHAT IS THE MCP402X DIGITAL POTENTIOMETER EVALUATION BOARD?

The MCP402X Digital Potentiometer Evaluation Board (MCP402XEV) allows the system designer to quickly evaluate the operation of Microchip Technology's MCP401X/2X Digital Potentiometer products.

The MCP402X Digital Potentiometer Evaluation Board PCB was designed to support:

- 8-pin, 150 mil SOIC MCP4021-XXX/SN devices
- SOT-23-6 MCP4022-XXX/OT devices
- SOT-23-6 MCP4023-XXX/OT devices
- SOT-23-5 MCP4024-XXX/OT devices
- 8-pin, 150 mil SOIC MCP4011-XXX/SN devices
- SOT-23-6 MCP4012-XXX/OT devices
- SOT-23-6 MCP4013-XXX/OT devices
- SOT-23-5 MCP4014-XXX/OT devices

In addition to supporting the MCP401X/2X, the MCP402XEV also utilizes the SOT-23-6 PIC10F20X microcontroller.

The PIC10F20X is supplied with example firmware that debounces the **INCR** and **DECR** push buttons and generates the simple U/D protocol required by the MCP401X/2X to increment and decrement the potentiometer's wiper. It also generates the simple U/D protocol required by the MCP402X to lock and unlock the potentiometer's wiper.

MCP401X/2X Evaluation Board User's Guide

1.3 WHAT THE MCP402X DIGITAL POTENTIOMETER EVALUATION BOARD KIT INCLUDES

This MCP402X Digital Potentiometer Evaluation Board Kit includes:

- One populated Printed Circuit Board (PCB)
 - MCP4021-103/OT
 - PIC10F206-I/OT with 00066_MCP402XEV.HEX programmed into memory
 - Two push button switches: one for Increment commands (INCR), one for Decrement commands (DECR)
 - Decoupling capacitors
 - 5 resistors to isolate the switches and create a voltage divider with the MCP4021-103/OT
- One blank PCB to allow rapid prototyping of a specific digital potentiometer configuration
- 2 samples each of the MCP4021-202/OT, MCP4021-502/OT, MCP4021-103/OT and MCP4021-503/OT
- 1 PIC10F20X-I/OT sample
- MCP401X/2X Digital Potentiometer Evaluation Board User's Guide (electronic version on CD) (DS51546)

Chapter 2. Installation and Operation

2.1 INTRODUCTION

The MCP402X Digital Potentiometer Evaluation Board provides a tested, out-of-the-box example of a MCP401X/2X application. The circuit description is described in **Section 2.2 “PCB Description”**, while the test and operating instructions are described in **Section 2.3 “Test and Operating Instructions”**. A supplied blank PCB allows rapid prototyping of the designer's specific MCP401X/2X device, along with other desired passive components (resistor and capacitors) and connection posts.

2.2 PCB DESCRIPTION

The MCP402X Digital Potentiometer Evaluation Board has the following features:

- 150 mil, 8-pin SOIC pinout (U1) supports the MCP4021 and MCP4011 devices
- SOT-23-6 pinout (U2) supports the MCP4022/23/24 and MCP4012/13/14 devices
- SOT-23-6 pinout (U3) supports the PIC10F20X devices
- Connection terminals can be left unpopulated for easy connection using small alligator clip leads (clamped across the edge of the board) or populated with either through-hole or surface-mount terminals
- Footprints for optional passive components for:
 - Power supply filtering
 - Device bypass capacitor
 - Terminal “A” pull-up resistor
 - Terminal “B” pull-down resistor
- Footprints for two switches:
 - **INCR** button operation can be detected by the PIC10F20X to generate Increment commands (move wiper toward terminal A)
 - **DECR** button operation can be detected by the PIC10F20X to generate Decrement commands (move wiper toward terminal B)
- Button sequence instructions are printed on the back of the PCB

Appendix A.2 “Schematic” illustrates the schematic for the MCP402XEV.

Note: The PIC10F20X firmware (00066_MCP402XEV.HEX) must be programmed into the microcontroller before the MCP402XEV is functional.

MCP401X/2X Evaluation Board User's Guide

2.2.1 Evaluating the MCP4021 and MCP4011

The MCP4021/11-XXXI/SN is an 8-pin digital potentiometer device with terminals A, B and W available on the device pins. Footprint U1 supports the 150 mil SOIC package. Resistors R2 and R3 are 2.5 k Ω on the populated PCB, along with the 10 k Ω MCP4021-103I/SN digital potentiometer. This creates a “windowed” voltage divider with a transfer function illustrated in Equation 2-1.

EQUATION 2-1: WINDOWED POTENTIOMETER – VOLTAGE DIVIDER CALCULATION

$$V_{wiper} = \frac{V_{DD} \cdot (R_{wb} + R3)}{R2 + R3 + R_{nom}} = \frac{5.0V \cdot ((d \cdot 10k) / 63 + 2.5k)}{2.5k + 2.5k + 10k}$$

Where:

d = the wiper setting (0 to 63)

Note 1: DO NOT populate U2 if using U1.

2: The MCP4011 has high-voltage tolerant pins and, therefore, accepts high-voltage Increment and Decrement commands. Since this device is nonvolatile, the WiperLock™ Technology feature is not present.

2.2.2 Evaluating the MCP4022 and MCP4012

The MCP4022/12-XXXI/OT is a 6-pin, stand-alone digital rheostat with terminals A and W available on the device pins. Footprint U2 supports the SOT-23-6 package. An “INCR” command moves the wiper toward terminal A, thus causing the resistance across the rheostat to decrease. A “DECR” command moves the wiper toward terminal B, thus causing the resistance across the rheostat to increase.

Note 1: DO NOT populate U1 if using U2.

2: The included MCP4021 digital potentiometer samples could be used to evaluate the MCP4022 simply by not populating R3 and letting terminal B float.

3: The MCP4012 has high-voltage tolerant pins and, therefore, accepts high-voltage Increment and Decrement commands. Since this device is nonvolatile, the WiperLock™ Technology feature is not present.

2.2.3 Evaluating the MCP4023 and MCP4013

The MCP4023/13-XXXI/OT is a 6-pin, grounded digital potentiometer with terminals A and W available on the device pins. Footprint U2 supports the SOT-23-6 package. Populating R2 will create a voltage divider with a transfer function illustrated in Equation 2-2.

EQUATION 2-2: GROUNDED POTENTIOMETER – VOLTAGE DIVIDER CALCULATION

$$V_{wiper} = \frac{V_{DD} \cdot R_{wb}}{R2 + R_{nom}} = \frac{5.0V \cdot (d \cdot 10k/63)}{2.5k + 10k}$$

Where:

d = the wiper setting (0 to 63)

Note 1: DO NOT populate U1 if using U2.

- 2:** The included MCP4021 digital potentiometer samples could be used to evaluate the MCP4023 simply by shorting terminal B to GND.
- 3:** The MCP4013 has high-voltage tolerant pins and, therefore, accepts high-voltage Increment and Decrement commands. Since this device is nonvolatile, the WiperLock™ Technology feature is not present.

2.2.4 Evaluating the MCP4024 and MCP4014

The MCP4024/14-xxxI/OT is a 5-pin, grounded digital rheostat with the W terminals available on the device pins. Footprint U2 supports the SOT-23-5 package. An “INCR” command moves the wiper toward terminal A, thus causing the resistance across the rheostat to increase. A “DECR” command moves the wiper toward terminal B, thus causing the resistance across the rheostat to decrease.

Note 1: DO NOT populate U1 if using U2.

- 2:** The included MCP4021 digital potentiometer samples could be used to evaluate the MCP4024 simply by not populating R₂, letting terminal A float and by shorting terminal B to GND.
- 3:** The MCP4014 has high-voltage tolerant pins and, therefore, accepts high-voltage Increment and Decrement commands. Since this device is nonvolatile, the WiperLock™ Technology feature is not present.

MCP401X/2X Evaluation Board User's Guide

2.3 TEST AND OPERATING INSTRUCTIONS

The populated PCB is configured to create a voltage divider from V_{DD} to V_{SS} using a 2.5 k Ω pull-up resistor (R2), the MCP4021-103I/SN (10 k Ω) and a 2.5 k Ω pull-down resistor (R3). To quickly evaluate the digital potentiometer's performance, the following test equipment is required:

- 2.7V to 5.5V power supply
- Voltmeter or Digital Multimeter (DMM)

Figure 2-1 shows the Digital Potentiometer Evaluation Board PCB, components and the connection points that will be used in the step-by-step demonstration.

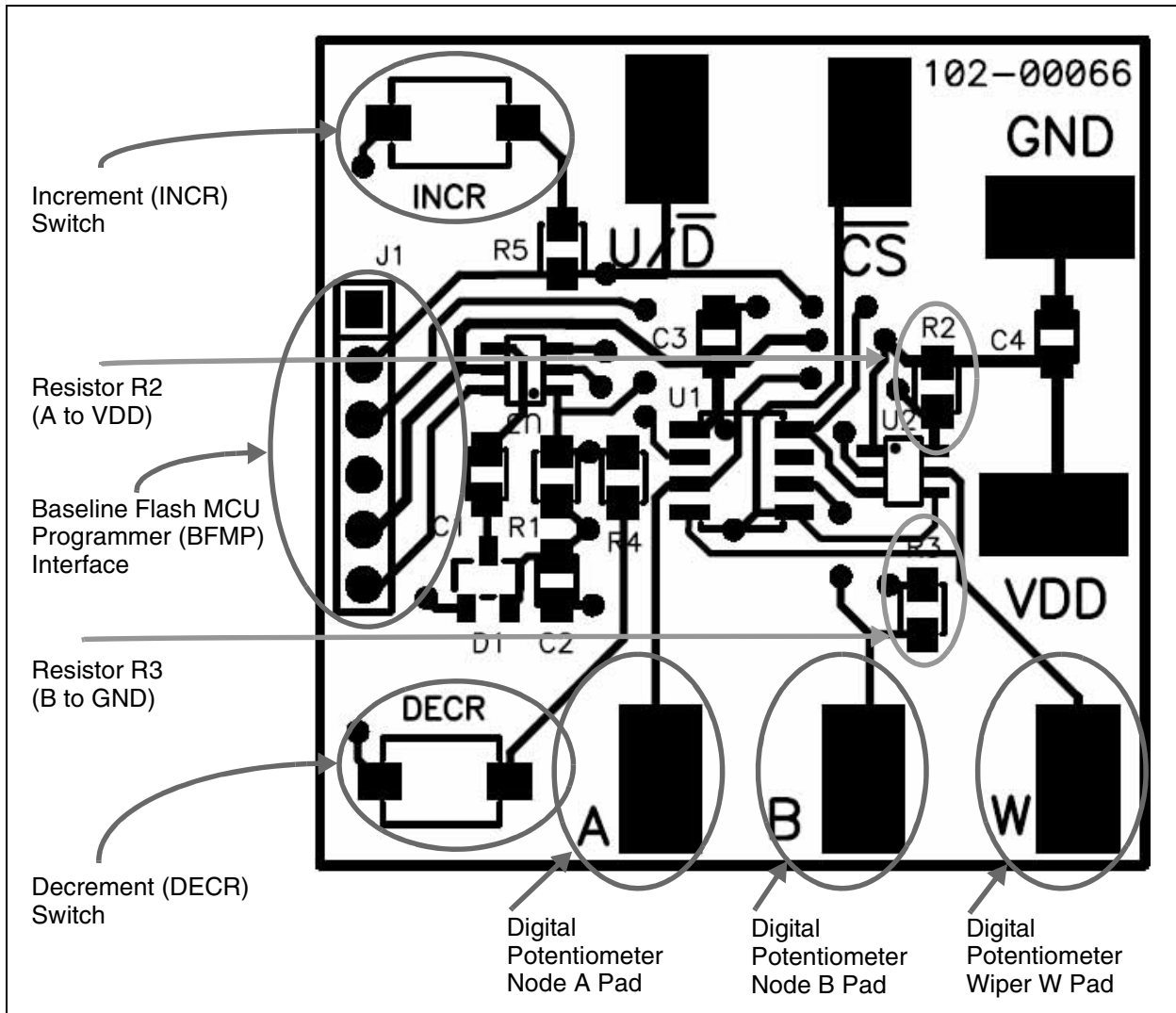

FIGURE 2-1: Digital Potentiometer Evaluation Board Overview.

2.3.1 Test Setup

1. Connect the power supply “+” to VDD and the “-” to GND.
2. Connect the voltmeter to the W terminal and GND.

The voltmeter should reflect the wiper setting with respect to Equation 2-3.

EQUATION 2-3: POPULATED PCB – VOLTAGE DIVIDER CALCULATION

$$V_{wiper} = \frac{V_{DD} \cdot (R_{wb} + R3)}{R2 + R3 + R_{AB}} = \frac{5.0V \cdot ((d \cdot 10k) / 63 + 2.5k)}{2.5k + 2.5k + 10k}$$

Where:

d = the wiper setting (0 to 63)

Using R2 and R3 = 2.5 kΩ:

- If a 2 kΩ MCP4021 is utilized, the output range will be approximately 1.79V to 3.21V.
- If a 5 kΩ MCP4021 is utilized, the output range will be approximately 1.25V to 3.75V.
- If a 10 kΩ MCP4021 is utilized, the output range will be approximately 0.83V to 4.17V.
- If a 50 kΩ MCP4021 is utilized, the output range will be approximately 0.23V to 4.77V.

2.3.2 MCP402X Digital Potentiometer Evaluation Board Firmware Operation

The 00066_MCP402XEV.HEX firmware programmed into the PIC10F20X provides a very simple interface to operate the MCP402X digital potentiometer. There are ten basic commands supported for the user to exercise the MCP402X digital potentiometer.

Table 2-1 shows the firmware commands of the Digital Potentiometer Evaluation Board.

MCP401X/2X Evaluation Board User's Guide

TABLE 2-1: DIGITAL POTENTIOMETER EVALUATION BOARD FIRMWARE INCREMENT/DECREMENT COMMANDS

#	Increment/Decrement - (Low Voltage/High Voltage)	Command					Button Sequence				
		# of Steps	Saves Wiper Value in EEPROM	High Voltage on CS and U/D pins?	After Command Wiper is "locked" / "unlocked"	Works when Wiper is "locked"	MCP401x will INCR/DECR	#1 (Depress) ⁽⁶⁾	#2 (Depress) ⁽⁶⁾	#3 (Release)	#4 (Release)
1	INCR - (Low Voltage)	1 ⁽¹⁾	Yes	No	—	No	Yes	INCR (for < 2 sec)	—	—	—
2	INCR - (High Voltage) ⁽⁶⁾	1 ⁽¹⁾	Yes	Yes	—	Yes	Yes	INCR (for < 2 sec)	DECREMENT (for < 2 sec)	INCR	DECR
3	INCR - (High Voltage) ⁽⁶⁾	1 ⁽¹⁾	Yes	Yes	Yes	Yes	Yes	INCR (for < 2 sec)	DECREMENT (for < 2 sec)	DECR	INCR
4	INCR - (Low Voltage)	64 ⁽²⁾	Yes	No	—	No	Yes	INCR (for > 2 sec)	—	—	—
5	INCR - (High Voltage) ⁽⁶⁾	64 ⁽²⁾	Yes	Yes	—	Yes	Yes	INCR (for < 2 sec)	DECREMENT (for > 2 sec)	INCR	DECR
6	DECR - (Low Voltage)	1 ⁽³⁾	Yes	No	—	No	Yes	DECR (for < 2 sec)	—	—	—
7	DECR - (High Voltage) ⁽⁶⁾	1 ⁽³⁾	Yes	Yes	—	Yes	Yes	DECR (for < 2 sec)	INCR (for < 2 sec)	DECR	INCR
8	DECR - (High Voltage) ⁽⁶⁾	1 ⁽³⁾	Yes	Yes	Yes	Yes	Yes	DECR (for < 2 sec)	INCR (for < 2 sec)	INCR	DECR
9	DECR - (Low Voltage)	64 ⁽⁴⁾	Yes	No	—	No	Yes	DECR (for > 2 sec)	—	—	—
10	DECR - (High Voltage) ⁽⁶⁾	64 ⁽⁴⁾	Yes	Yes	—	Yes	Yes	DECR (for < 2 sec)	INCR (for > 2 sec)	DECR	INCR

Note 1: Move wiper W towards node A (Increment wiper 1 step).

2: Move wiper W to node A (Increment wiper 64 steps). Forces the wiper setting to "full-scale" (wiper W = node A).

3: Move wiper W towards node B (Decrement wiper 1 step).

4: Move wiper W to node B (Decrement wiper 64 steps). Forces the wiper setting to "zero scale" (wiper W = node B).

5: If there is more than one sequence, the button sequence #1 must continue to be held down while progressing to sequence #2. Example: Command # 2. requires the **INCR** button to be depressed. Then, before 2 seconds elapses, the **DECR** button must be depressed. Next, before 2 seconds elapses, the **INCR** button must be released. The **DECR** button can then be released.

6: High-voltage commands require a system voltage (V_{DD}) greater than 5.0V to allow the simple charge pump to generate the $V_{IHH\ MIN}$ voltage for the \overline{CS} pin.

MCP401X/2X Evaluation Board User's Guide

2.3.3 Running the Ratiometric Voltage Demo

Table 2-2 provides step-by-step instructions to perform a demonstration of the MCP402X Digital Potentiometer Evaluation Board. Measuring Ratiometric Voltage

TABLE 2-2: MEASURING RATIOMETRIC VOLTAGE

Step	Action	Result
1	Power up the populated Digital Potentiometer Evaluation Board. Voltage calculations use a system voltage of 5V.	—
	Board can be powered via a valid voltage (such as 5V) on the VDD and GND PCB Pads, or by connecting a BFMP programmer that is connected to an active PC's USB port (powered via the USB connection).	
2	Set DMM to measure the required voltage range (0V to 5.5V). Connect the DMM ground connection to the evaluation board GND terminal and the DMM V/ Ω connection to terminal W of the evaluation board.	—
3	Turn on DMM.	On DMM: DMM will display the voltage determined by the current non-volatile setting of the wiper.
4	On the Digital Potentiometer Evaluation Board: Implement Command #5 (see Table 2-1).	On the Digital Potentiometer Evaluation Board: WiperLock™ Technology is disabled and the wiper is incremented from power-on position.
		On DMM: Voltage increments approximately 0.05V.
5	On the Digital Potentiometer Evaluation Board: Implement Command #4 (see Table 2-1).	On the Digital Potentiometer Evaluation Board: Wiper is forced to the full-scale position (Wiper W = node A).
		On DMM: Voltage equals approximately 4.17V.
6	On the Digital Potentiometer Evaluation Board: Implement Command #6 (see Table 2-1).	On the Digital Potentiometer Evaluation Board: Wiper is decremented one position from the full-scale position.
		On DMM: Voltage equals approximately 4.12V.
7	On the Digital Potentiometer Evaluation Board: Implement Command #6 (see Table 2-1) 15 more times.	On the Digital Potentiometer Evaluation Board: Wiper is decremented to the 25% position from node A (full-scale) to node B (zero-scale).
		On DMM: Voltage equals approximately 3.33V.
8	On the Digital Potentiometer Evaluation Board: Turn off/disconnect power supply.	On DMM: Voltage equals approximately 0V.
9	On the Digital Potentiometer Evaluation Board: Reapply power to Digital Potentiometer Evaluation Board.	On DMM: Voltage equals approximately 3.33V. This shows that the MCP4021 retained the last selected wiper setting.
10	On the Digital Potentiometer Evaluation Board: Implement Command #3 (see Table 2-1).	On the Digital Potentiometer Evaluation Board: Wiper is incremented one position and the wiper is locked (WiperLock Technology is enabled).
		On DMM: Voltage equals approximately 3.38V.

Installation and Operation

TABLE 2-2: MEASURING RATIO-METRIC VOLTAGE (CONTINUED)

Step	Action	Result
11	On the Digital Potentiometer Evaluation Board: Implement Command #1 (see Table 2-1).	On the Digital Potentiometer Evaluation Board: Wiper is NOT moved due to the wiper being locked (WiperLock™ Technology is enabled).
		On DMM: Voltage equals approximately 3.38V.
12	On the Digital Potentiometer Evaluation Board: Turn off/disconnect power supply.	On DMM: Voltage equals approximately 0V.
13	On the Digital Potentiometer Evaluation Board: Re-apply power to Digital Potentiometer Evaluation Board.	On DMM: Voltage equals approximately 3.38V. This shows that the MCP4021 retained the last saved wiper setting.

MCP401X/2X Evaluation Board User's Guide

2.3.4 Wiper Voltages

Table 2-3 shows the relation between the wiper position and the voltage on the wiper when 5.0 volts is applied to the MCP402X Digital Potentiometer Evaluation Board where the resistors R2 and R3 are 2500Ω and the MCP4011 resistor value (R_{AB}) is 10 kΩ. Equation 2-4 shows the formula for these calculations.

EQUATION 2-4: CALCULATING THE VOLTAGE ON THE MCP402X DIGITAL POTENTIOMETER EVALUATION BOARD

$$\text{Voltage at Wiper} = \text{System } V_{DD} \cdot \frac{(R3 + (\text{Wiper Position} \cdot (R_{AB}/63)))}{R3 + R_{AB} + R2}$$

Where:

System V_{DD} = 5.0V
R2 = 2.5 kΩ
R3 = 2.5 kΩ
R_{AB} = 10 kΩ

The typical step resistance for the 10 kΩ MCP4021 is approximately 158.73Ω. With a 5V supply and a 15 kΩ total resistance (2.5 kΩ + 2.5 kΩ + 10 kΩ), the delta voltage per step is approximately 0.053V.

TABLE 2-3: WIPER POSITION AND CORRESPONDING VOLTAGE

Wiper		Wiper		Wiper		Wiper	
Position	Voltage (V)	Position	Voltage (V)	Position	Voltage (V)	Position	Voltage (V)
00 ⁽¹⁾	0.833	16	1.680	32	2.526	48	3.373
01	0.866	17	1.733	33	2.579	49	3.426
02	0.939	18	1.786	34	2.632	50	3.479
03	0.992	19	1.839	35	2.685	51	3.532
04	1.045	20	1.892	36	2.738	52	3.585
05	1.098	21	1.944	37	2.791	53	3.638
06	1.151	22	1.997	38	2.844	54	3.690
07	1.204	23	2.050	39	2.897	55	3.743
08	1.257	24	2.103	40	2.950	56	3.796
09	1.310	25	2.156	41	3.003	57	3.849
10	1.362	26	2.209	42	3.056	58	3.902
11	1.415	27	2.262	43	3.108	59	3.955
12	1.468	28	2.315	44	3.161	60	4.008
13	1.521	29	2.368	45	3.214	61	4.061
14	1.574	30	2.421	46	3.267	62	4.114
15	1.627	31	2.474	47	3.320	63 ⁽²⁾	4.167

Note 1: This is zero-scale, wiper is connected to terminal B.

2: This is full-scale, wiper is connected to terminal A.

2.4 FIRMWARE DESCRIPTION

The 000066_MCP402XEV.ASM source code was written using assembly language for the PIC10F206 microcontroller. Refer to **Appendix E. “00066_MCP402XEV.ASM Source Code”**. The firmware initializes its I/O so that it can poll the **INCR** and **DECR** buttons every millisecond. If the button has been depressed for 40 out of 50 ms, it is considered to be debounced and asserted. The button state is used to determine if a new “Action State” is desired. This simple state machine then decodes the desired action. Once the desired command has been determined, a subroutine that performs the desired command is executed. The low-voltage commands are driven directly from the PIC10F206 I/O, but the high-voltage commands require some additional hardware to generate the required 8V signal.

When a high-voltage command is required, the PIC10F206’s unique OSCOUT feature is utilized. The OSCOUT function allows the instruction clock to be driven on GP2/OSCOUT under software control. A simple charge pump consisting of 2 – 0.01 μ F capacitors and a BAV99 dual diode is constructed as seen in **Appendix A.2 “Schematic”**. When the OSCOUT is enabled, a 1 MHz clock drives the charge pump that produces an 8.4V signal on the MCP401X/2X’s CS pin (assuming $V_{DD} = 5.0V$). Utilizing such a charge pump requires special attention to the timing of the CS & U/D signals.

Refer to the comments in the 00066_MCP402XEV.ASM source code for more details on the firmware’s operation. Refer to **Appendix E. “00066_MCP402XEV.ASM Source Code”**.

MCP401X/2X Evaluation Board User's Guide

NOTES:

Appendix A. Schematic and Layouts

A.1 INTRODUCTION

This appendix contains the following schematics and layout diagrams for the MCP402X Digital Potentiometer Evaluation Board.

- Schematic – Shows the schematic of the MCP402X Digital Potentiometer Evaluation Board. The populated PCB was built using this schematic.
- Board Layout – Top Layer + Silk-screen
- Board Layout – Top Silk-Screen
- Board Layout – Bottom Layer + Silk-screen
- Board Layout – Bottom Layer

MCP401X/2X Evaluation Board User's Guide

A.2 SCHEMATIC

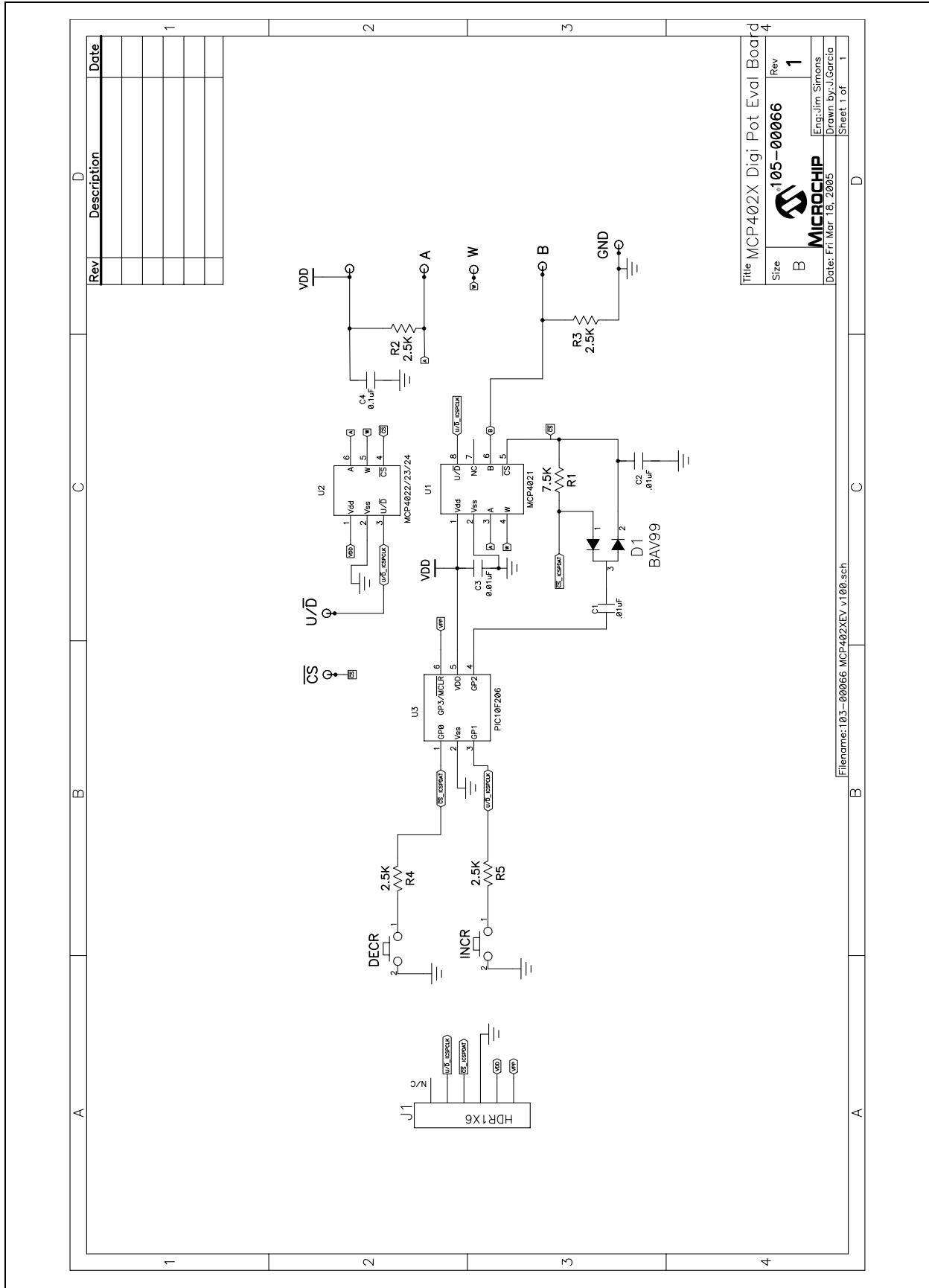

A.3 MCP402X BOARD LAYOUT – TOP LAYER + SILK-SCREEN

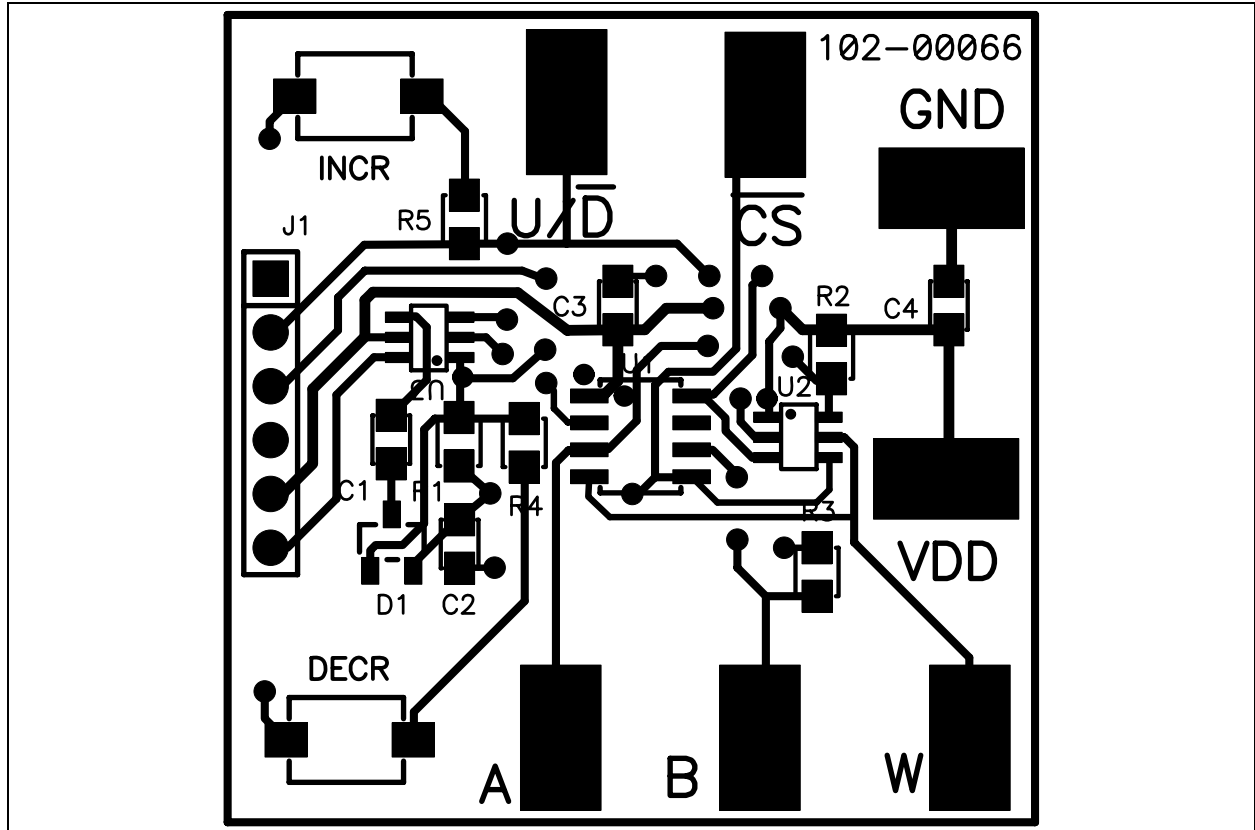

A.4 MCP402X BOARD LAYOUT – BOTTOM LAYER

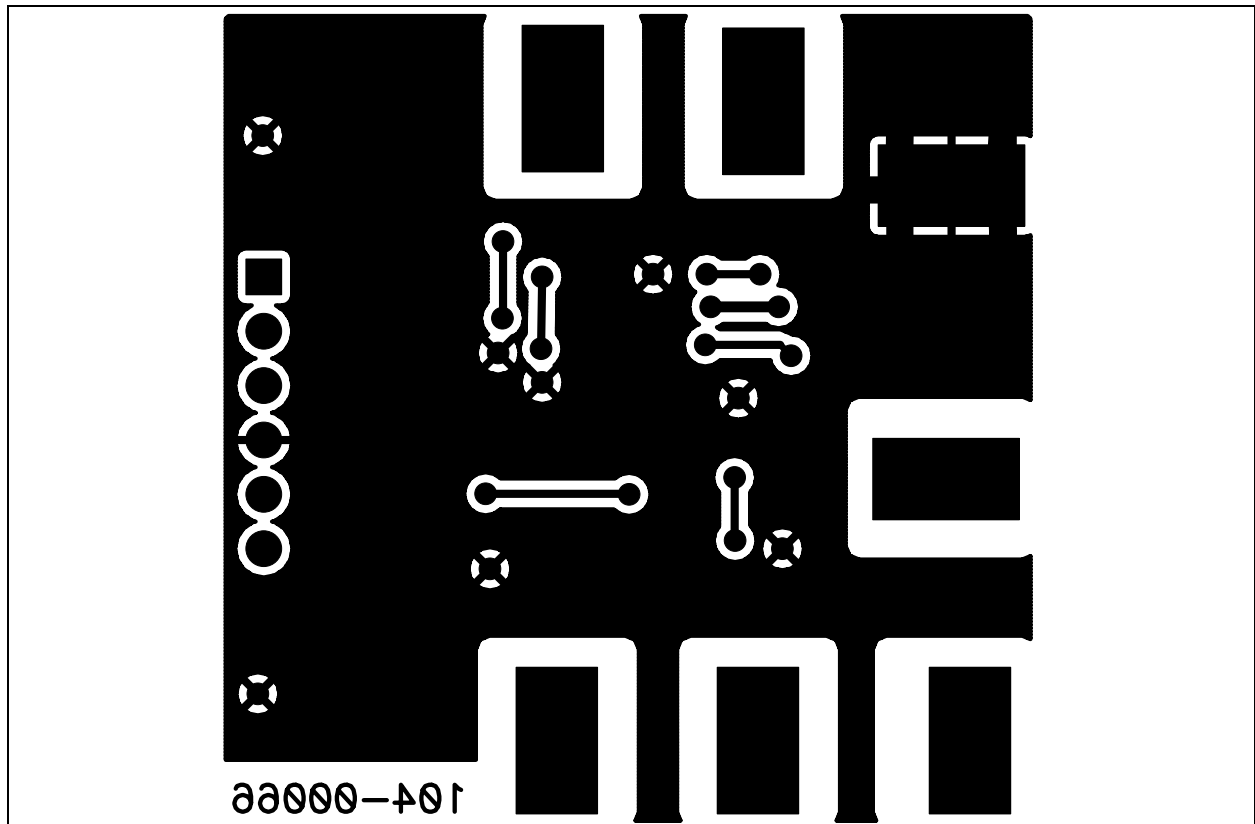

MCP401X/2X Evaluation Board User's Guide

A.5 MCP402X BOARD LAYOUT – TOP SILK-SCREEN

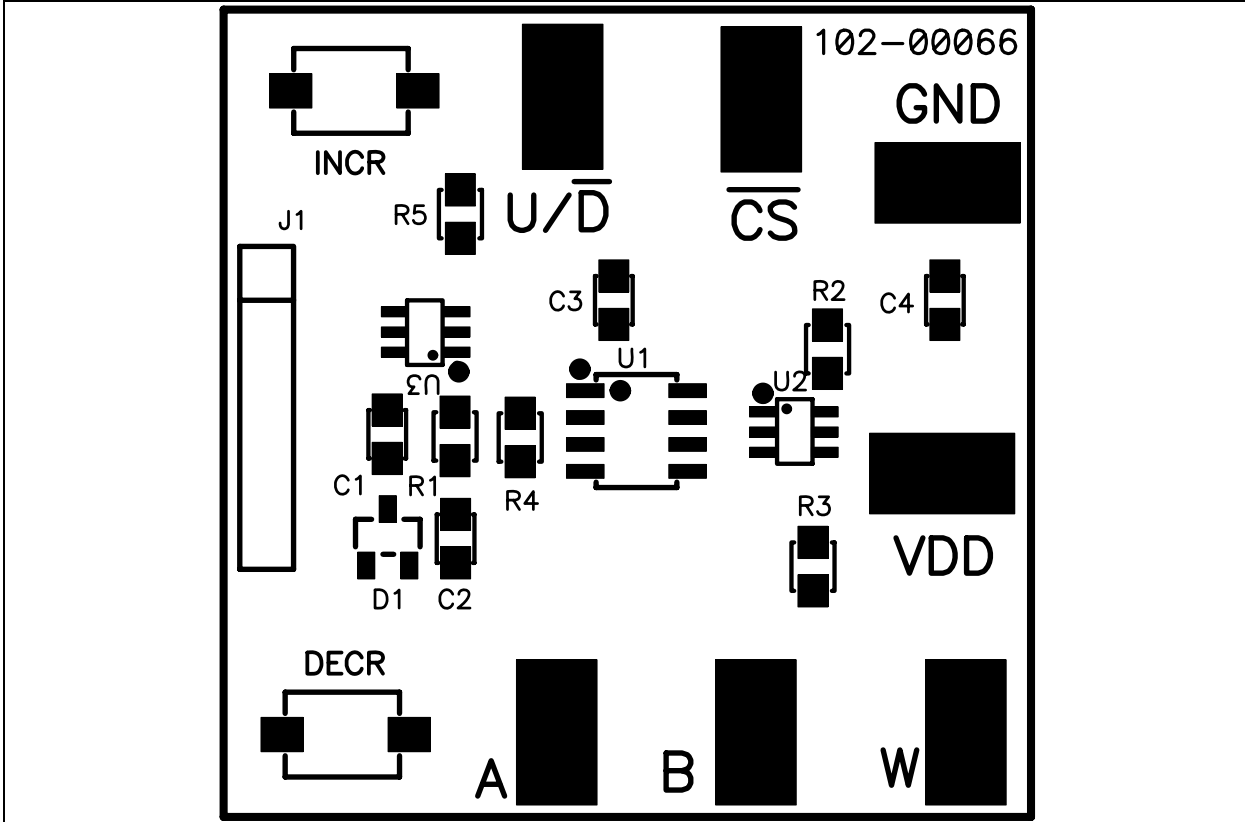

A.6 MCP402X BOARD LAYOUT – BOTTOM LAYER + SILK-SCREEN

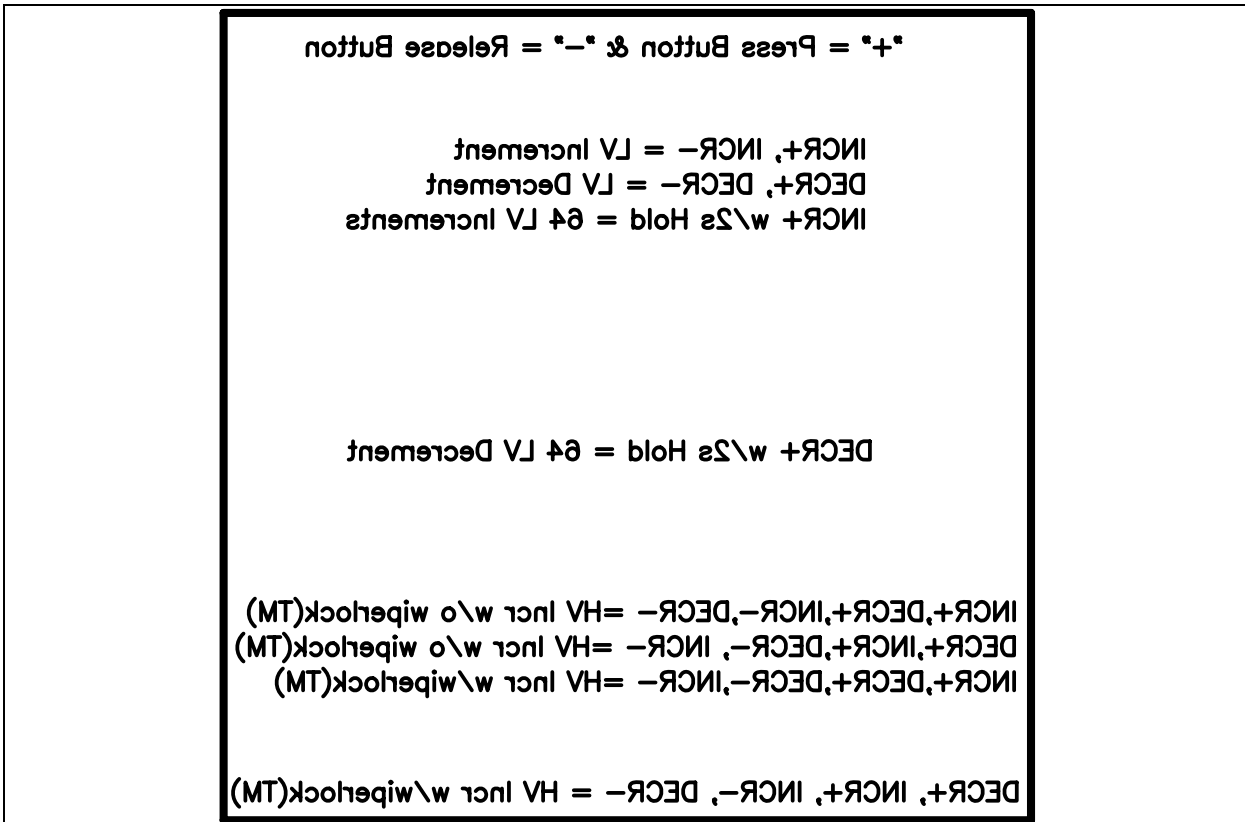

Appendix B. Bill Of Materials (BOM)

TABLE B-1: BILL OF MATERIALS

Qty	Reference	Description	Manufacturer	Part Number
2	C1,C2,C3	Cap 0.01 μ F 50V CERAMIC X7R 0805	Kemet [®]	C0805C103K5RACTU
1	C4	Cap .1 μ F 25V CERAMIC X7R 0805	Panasonic [®] Corporation – ECG	ECJ-2VB1E104K
1	D1	Dual Diode, SOT-23-3, May substitute with Fairchild [®] BAV99	ON Semiconductor [®]	BAV99LT1
2	INCR, DECR	Switch LT Touch 6X3.5 100 GF SMD	Panasonic Corporation – ECG	EVQ-PJS04K
1	J1	Conn Header 6pos .100 VERT TIN (Optional)	Molex [®] /Waldom [®] Electronics Corp	22-28-4061
1	R1	Res 7.5 k Ω 1/10W 1% 0805 SMD	Panasonic Corporation – ECG	ERJ-6ENF5111V
2	R2,R3	Res 2.5 k Ω 1/10W 1% 0805 SMD	Panasonic Corporation – ECG	ERJ-6ENF5111V
2	R4,R5	Res 2.5 k Ω 1/10W 1% 0805 SMD	Panasonic Corporation – ECG	ERJ-6ENF5111V
1	U1	MCP4021-103/SN 10 k Ω Digital Potentiometer	Microchip Technology Inc.	MCP4021-103/SN
1	U3	PIC10F206, 6-Pin, 8-Bit Flash Microcontrollers	Microchip Technology Inc.	PIC10F206-I/OT
1	U2	MCP4022/23/24 5/6 Pin Digital Potentiometer (Optional)	Microchip Technology Inc.	MCP4024-502/OT
7	A,B,W,VDD,GND, U/D,CS	Test Point PC Compact SMT (Optional)	Keystone [®] Electronics	5016

MCP401X/2X Evaluation Board User's Guide

NOTES:

Appendix C. Using the BFMP Programmer to Power the Board

C.1 POWERING THE BOARD USING THE BFMP PROGRAMMER

The BFMP programmer (PG164101) uses a 6-pin interface for programming. The PICkit™ 2 Flash Starter Kit (PG164120 or DV164120) uses the same interface.

The MCP402X Digital Potentiometer Evaluation Board (MCP402XEV) plugs into the BFMP (or PICkit™ 2 Flash Starter Kit) in the orientation shown in Figure C-1.

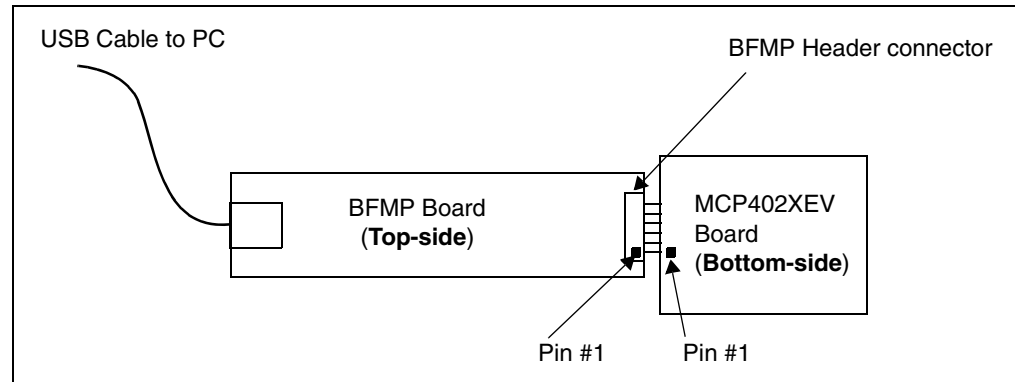

FIGURE C-1: *BFMP Hardware and MCP402X Digital Potentiometer Evaluation Board.*

MCP401X/2X Evaluation Board User's Guide

These programmers use the PICkit™ 1 Baseline Flash Programmer software. This GUI should be configured as shown in Figure C-2. Selecting **Device Power** causes the BFMP to power the attached board all the time (not just during programming). This allows the MCP402X Digital Potentiometer Evaluation Board to be easily demonstrated without needing to carry a power supply (although a DMM is still required).

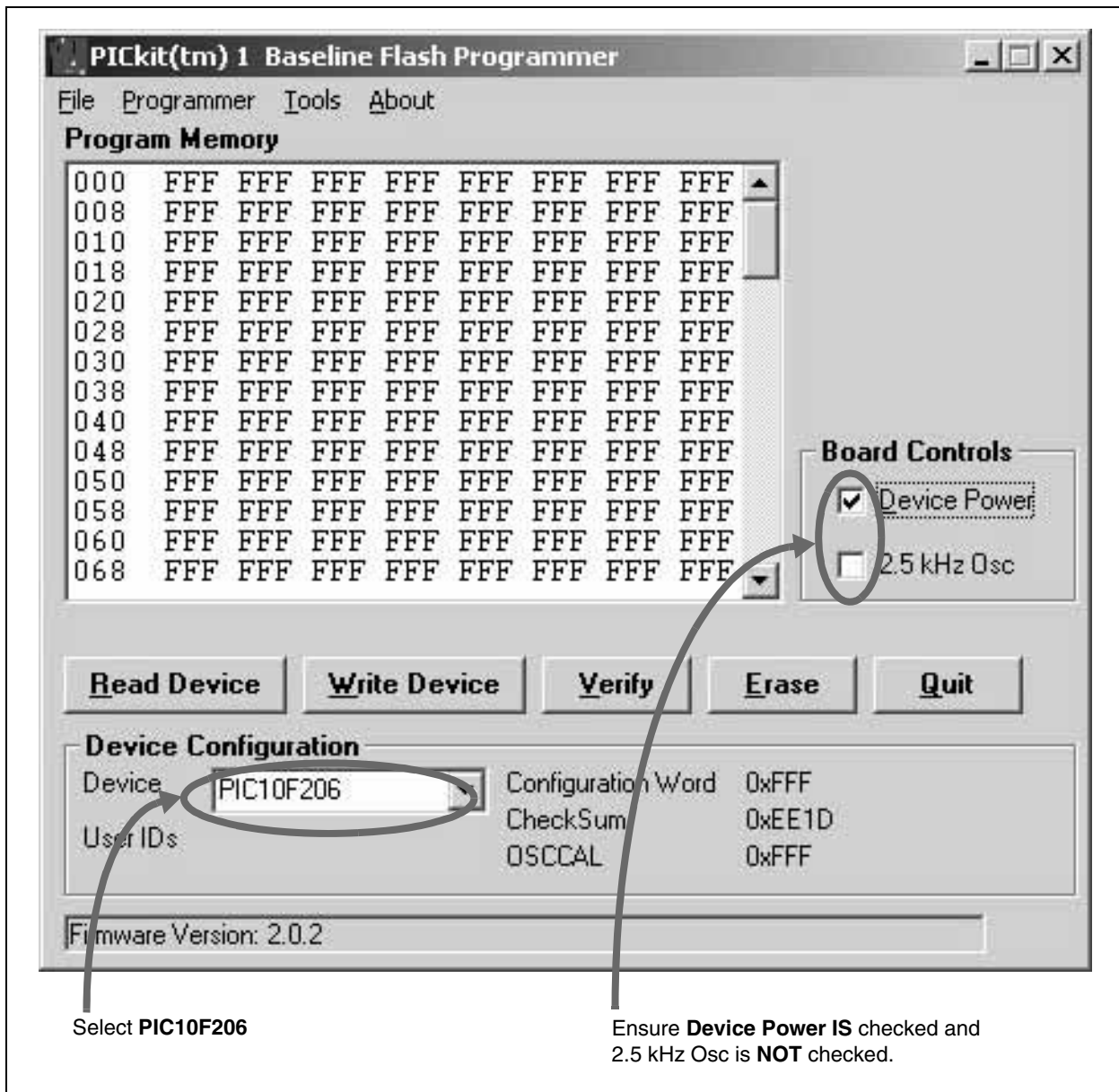

FIGURE C-2: PICkit™ 1 Baseline Flash Programmer - Configuration #2.

Note: When programming the MCP402X Digital Potentiometer Evaluation Board, under "Board Controls", DO NOT check **Device Power**. This ensures that the PIC10F206 is only powered during the programming cycle.

Appendix D. Potential Programming Issue of the MCP402XEV

D.1 INTRODUCTION

When programming the MCP402XEV with a Microchip programmer (such as the BPMF or MPLAB[®] ICD 2), the PIC10F206 may not program correctly due to the load on the ICSPDAT pin. **This issue relates to PCBs marked 104-00066 and 104-00066R2.**

Due to the current path to ground that is present with the D1 and R1 components through capacitor C2, the programming voltage on the ICSPDAT signal may not meet the voltage requirements of the PIC10F206 GP1 pin.

To address this when programming the board, lift up one of the terminals of capacitor C2 (see Figure D-1). This will stop the ICSPDAT signal voltage from being loaded down while capacitor C2 is charging. The schematic is shown in Figure D-2.

After programming, capacitor C2 must be reconnected to the circuit. This is because this circuit generates the high voltage for the high voltage commands.

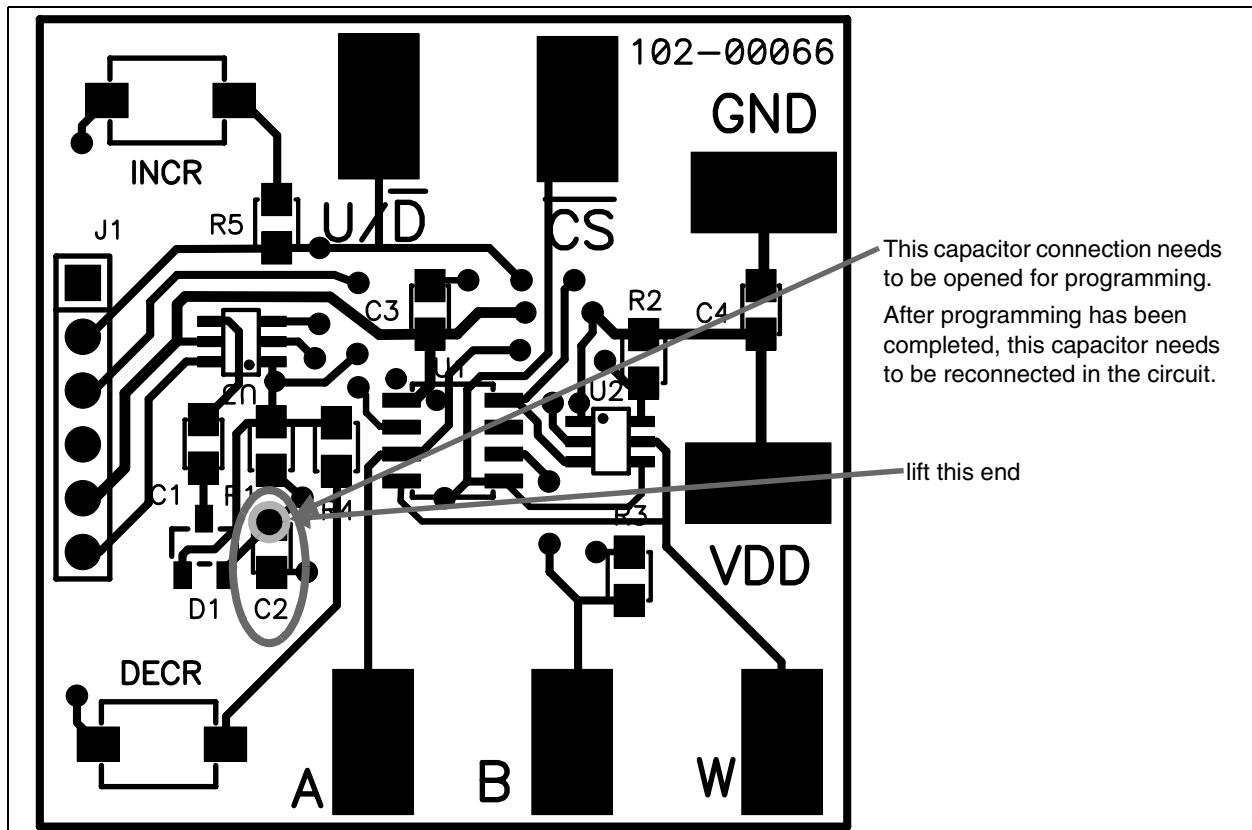

FIGURE D-1: MCP402XEV R2 PCB Layout – ECN #1.

MCP401X/2X Evaluation Board User's Guide

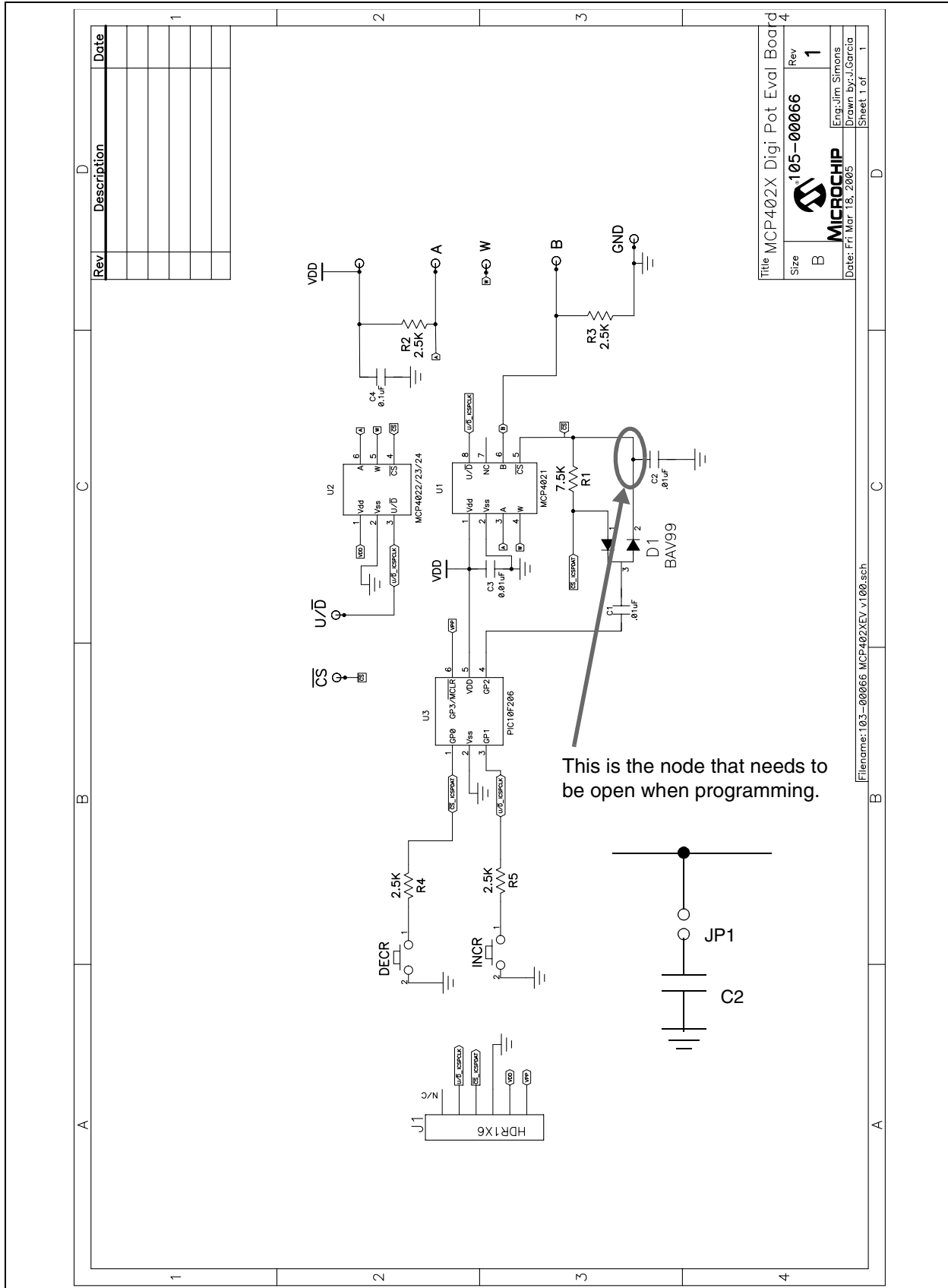

FIGURE D-2: MCP402XEV R2 Schematic PCB R2, ECN #1.



MCP401X/2X EVALUATION BOARD USER'S GUIDE

Appendix E. 00066_MCP402XEV.ASM Source Code

E.1 INTRODUCTION

This appendix documents the example PIC10F20X source code used on the populated PCB. The source code is described in detail by the comments within the .ASM file. The 00066_MCP402XEV.ASM, PIC10F206.INC and MCP402XEV.HEX files can be found on the Microchip web site (www.microchip.com) and on the included CD.

Software License Agreement

The software supplied herewith by Microchip Technology Incorporated (the "Company") is intended and supplied to you, the Company's customer, for use solely and exclusively with products manufactured by the Company.

The software is owned by the Company and/or its supplier, and is protected under applicable copyright laws. All rights are reserved. Any use in violation of the foregoing restrictions may subject the user to criminal sanctions under applicable laws, as well as to civil liability for the breach of the terms and conditions of this license.

THIS SOFTWARE IS PROVIDED IN AN "AS IS" CONDITION. NO WARRANTIES, WHETHER EXPRESS, IMPLIED OR STATUTORY, INCLUDING, BUT NOT LIMITED TO, IMPLIED WARRANTIES OF MERCHANTABILITY AND FITNESS FOR A PARTICULAR PURPOSE APPLY TO THIS SOFTWARE. THE COMPANY SHALL NOT, IN ANY CIRCUMSTANCES, BE LIABLE FOR SPECIAL, INCIDENTAL OR CONSEQUENTIAL DAMAGES, FOR ANY REASON WHATSOEVER.

TABLE E-1: 00066_MCP402XEV.ASM SOURCE CODE

```

TITLE "MCP402XEV Firmware"
;*****
; Author:    Jim Simons
; Tools:    MPLAB (r) 7.10 using MPLINK(tm)
; Editor:    ComicSans 8pt w/8 character Tabs
; Files:    00066_MCP402XEV.asm
;           p10f206.inc
;
; Description:  Exercise the MCP402x devices using the MCP402x EV board.
;              Simply use the INCR & DECR buttons to execute the INCR & DECR serial commands.
;
; Serial Commands      Action                                          State
;
; LV Increment w/EE    Depress UP, Release UP      LVwEE = 1      3
; LV Decrement w/EE    Depress DOWN, Release DOWN  LVwEE = 1      4
; LV Increment w/o EE  Depress UP, Release UP      LVwEE = x      3
; LV Decrement w/o EE  Depress DOWN, Release DOWN  LVwEE = x      4
; LV 64 Increments     Depress UP, Hold for 2s, Release UP                1
; LV 64 Decrements     Depress DOWN, Hold for 2s, Release DOWN            2
; HV Incr w/o WL       Depress UP, Depress DOWN, Release UP, Release DOWN  11
; HV Decr w/o WL       Depress DOWN, Depress UP, Release DOWN, Release UP  12
; HV 64 Incr w/o WL    Depress UP, Depress DOWN, Hold for 2s, Release UP, Release DOWN  5
; HV 64 Decr w/o WL    Depress DOWN, Depress UP, Hold for 2s, Release DOWN, Release UP  6
; HV Incr w/WL         Depress UP, Depress DOWN, Release DOWN, Release UP  13
; HV Decr w/WL         Depress DOWN, Depress UP, Release UP, Release DOWN  14
;

```

00066_MCP402XEV.ASM Source Code

TABLE E-1: 00066_MCP402XEV.ASM SOURCE CODE (CONTINUED)

```

;*****
; Connections/Schematic
;*****
;
; MCP pin      MCP4021      MCP4022      MCP4023      MCP4024
; -----
; 1            Vdd            Vdd            Vdd            Vdd
; 2            Vss            Vss            Vss            Vss
; 3            A              U/D            U/D            U/D
; 4            W              CS              CS              CS
; 5            CS              W              W              W
; 6            B              A              A              -
; 7            -              -              -              -
; 8            U/D            -              -              -
;
; MCP402x      PIC10F206                                Ext Components
; -----
; Vdd          Vdd                                0.1uF - Vss
; Vss          Vss                                -
; A            -                                2.5k - Vdd
; W            -                                -
; B            -                                2.5k - Vss
; CS           GP0/ICSPDAT (int pu)             2.5k - DECR - Vss, 7.5k - CS & BAV99
; U/D          GP1/ICSPCLK (int pu)             2.5k - INCR - Vss
; -            GP2/OSCOUT                       0.01uF - BAV99 - 0.01uF - Vss
; -            GP3/Vpp (int pu)                 optional SW or Jumper put on BFMP header pins 4 & 6
;
;*****
; Assemble Time Variables
SaveWiper equ 1 ; comment this line prevent LV commands from Saving the Wiper
;
;*****
; Configure the PIC
;*****

list      p=10F206 ; list directive to define processor
#include <p10F206.inc> ; processor specific variable definitions

__CONFIG _MCLRE_OFF & _CP_OFF & _WDT_ON

ERRORLEVEL -302

```

00066_MCP402XEV.ASM Source Code

TABLE E-1: 00066_MCP402XEV.ASM SOURCE CODE (CONTINUED)

```

;*****
; General Purpose Register Definitions
;*****
GPRS          UDATA
State         res      1      ; variable to track the "state" value
              ; this code functions as a state machine
              ; bits 3:0 stores the state 0-15 indicator
              ; bits 7:6 stores the debounced button states
OldState     res      1      ; allows program to see if State changed
Exit         res      1      ; variable to count the number ms to test for a button press
DebounceUP   res      1      ; variable to count the number of ms UP was pressed
DebounceDOWN res      1      ; variable to count the number of ms DOWN was pressed
DLYCNT1      res      1      ; variable for the delay subroutines
DLYCNT2      res      1      ; variable for the delay subroutines

#define UD     GPIO,1      ; GP1 tied to UD & has "INCR" switch connected via 2.2k resistor
#define CS     GPIO,0      ; GP0 tied to CS & has "DECR" switch connected via 2.2k resistor
#define UP     GPIO,1      ; Momentary switch UP
#define DOWN   GPIO,0      ; Momentary switch DOWN
#define CP     GPIO,2      ; OSCOUT pin for Charge Pump
#define PowerDown GPIO,3 ; Vpp for programming & PowerDown input to put uC to SLEEP

#define HV_CS  OSCCAL,FOSC4 ; Drives CS to HVDD (drive CS high first)

#define UP_State State,7 ; Debounced UP State - using bits 5:4 are critical
#define DOWN_State State,6 ; Debounced DOWN State - using bits 5:4 are critical

;*****
; Reset Code
;*****
RESET        CODE          ; processor reset vector + 1
;ResetVector ; Device resets to 0x1FF to get the factory calibration
              goto Start   ; Lower half of memory reserved for subroutines

;*****
; Main Code
;*****
MAIN         CODE
Start
Init_Oscillator
; Internal RC calibration value is placed at location 0xFF by Microchip
; as a movlw k, where the k is a literal value.
      movwf OSCCAL      ; update register with factory cal value
;      bcf  OSCCAL,FOSC4 ; make sure the FOSC4 is disabled to shut charge pump off

StateMachineReset
      movlw b'11110011' ; Disable the Comparator & make inputs digital
      movwf CMCON0
;      bcf  CMCON0, CMPON ; needs to be on to get GP2 as a General Purpose Output
      movlw b'10011010' ; disable Wake-Up on Pin Change,
                        ; enable weak pullups for button inputs
                        ; T0CS must be 0 for GP2 TRIS to be active
                        ; set up for 72ms WDT

      option

Init
      clrf State
      clrf OldState
      call InitGPIO ; make GP0/DECR/CS & GP1/INCR/UD outputs, block undesired U/D commands

```

00066_MCP402XEV.ASM Source Code

TABLE E-1: 00066_MCP402XEV.ASM SOURCE CODE (CONTINUED)

```
ButtonCheck          ; Debounce Buttons
    btfss PowerDown  ; If pulled low, put uC to SLEEP
    goto LowPowerMode
    bsf UP_State
    bsf DOWN_State   ; initialize Button_State to indicate no button pressed
    movlw .50        ; debounce the buttons for 50ms to see if pressed
    movwf Exit
    movlw .40        ; if pushed for 40 of 50 tests, then valid UP
    movwf DebounceUP
    movwf DebounceDOWN

DebounceLoop
    call GPIO_TestUP ; make GP1/INCR/UD an input (w/pu enabled)
    movlw .99
    call VAR5TcyDELAY ; 5 + (99*5) = 500us
    btfss UP
    decfsz DebounceUP,f
    goto CheckDOWN
    bcf UP_State     ; UP Button Pressed

CheckDOWN
    call GPIO_TestDOWN ; make GP0/DECR/CS an input (w/pu enabled)
    movlw .99
    call VAR5TcyDELAY ; 5 + (99*5) = 500us
    btfss DOWN
    decfsz DebounceDOWN,f
    goto DebounceLoopTest
    bcf DOWN_State   ; DOWN Button Pressed

DebounceLoopTest
    decfsz Exit,f
    goto DebounceLoop

    call InitGPIO    ; make GP0/DECR/CS & GP1/INCR/UD outputs, block undesired U/D commands
    movf State,w
    call DetermineState ; subroutine to determine the next state
    movwf State
    xorwf OldState,w
    btfss STATUS,Z
    call PerformState  ; State changed, now do something
    movlw .5
    call VAR1000TcyDELAY ; Make sure EE Write Cycle has finished
    movf State,w
    movwf OldState
    goto ButtonCheck  ; Loop for button presses

;*****
; State Machine Code
;*****
State0    goto StateMachineReset ; State 0, no action, shouldn't get here

State1          ; UP button pressed
    movlw .200    ; 200x10mS = 2s
    movwf Exit
```

00066_MCP402XEV.ASM Source Code

TABLE E-1: 00066_MCP402XEV.ASM SOURCE CODE (CONTINUED)

```
Loop1_2sec
  call  GPIO_TestDOWN      ; make GP0/DECR/CS an input (w/pu enabled)
  movlw .5                 ; 5ms delay
  call  VAR1000TcyDELAY
  btfss DOWN              ; if DOWN gets pressed, exit
  retlw .1
  call  GPIO_TestUP       ; make GP1/INCR/UD an input (w/pu enabled)
  movlw .5                 ; 5ms delay
  call  VAR1000TcyDELAY
  btfsc UP                ; if UP gets released, exit
  retlw .1
  decfsz Exit,f
  goto  Loop1_2sec
  call  InitGPIO          ; make GP0/DECR/CS & GP1/INCR/UD outputs, block undesired U/D commands
  movlw .64
  call  LV_Increment
;  movlw .4
;  call  VAR1000TcyDELAY   ; add a 4mS delay for E/W cycle
  call  GPIO_TestUP       ; make GP1/INCR/UD an input (w/pu enabled)
LV_IncrExit
  clrwdt
  btfss UP                ; if UP gets released, exit
  goto  LV_IncrExit
  clrf  State
  retlw .1
State2
; DOWN button pressed
  movlw .200              ; 200x10mS = 2s
  movwf Exit
Loop2_2sec
  call  GPIO_TestUP       ; make GP1/INCR/UD an input (w/pu enabled)
  movlw .5                 ; 5ms delay
  call  VAR1000TcyDELAY
  btfss UP                ; if UP gets pressed, exit
  retlw .2
  call  GPIO_TestDOWN     ; make GP0/DECR/CS an input (w/pu enabled)
  movlw .5                 ; 5ms delay
  call  VAR1000TcyDELAY
  btfsc DOWN             ; if DOWN gets released, exit
  retlw .2
  decfsz Exit,f
  goto  Loop2_2sec
  call  InitGPIO          ; make GP0/DECR/CS & GP1/INCR/UD outputs, block undesired U/D commands
undesired U/D commands
  movlw .64
  call  LV_Decrement
;  movlw .4
;  call  VAR1000TcyDELAY   ; add a 4mS delay for E/W cycle
  call  GPIO_TestDOWN     ; make GP0/DECR/CS an input (w/pu enabled)
LV_DecrExit
  clrwdt
  btfss DOWN             ; if DOWN gets released, exit
  goto  LV_DecrExit
  clrf  State
  retlw .2
State3
; LV Increment
  call  InitGPIO          ; make GP0/DECR/CS & GP1/INCR/UD outputs, block undesired U/D commands
  movlw .1
  call  LV_Increment
  clrf  State
  retlw .3
```

00066_MCP402XEV.ASM Source Code

TABLE E-1: 00066_MCP402XEV.ASM SOURCE CODE (CONTINUED)

```
State4                                ; LV Decrement
call  InitGPIO                        ; make GP0/DECR/CS & GP1/INCR/UD outputs, block undesired U/D commands
movlw .1
call  LV_Decrement
clrf  State
retlw .4

State5                                ; Both buttons pressed
movlw .200                            ; 200x10mS = 2s
movwf Exit

Loop5_2sec
call  GPIO_TestUP                    ; make GP1/INCR/UD an input (w/pu enabled)
movlw .5                              ; 5ms delay
call  VAR1000TcyDELAY
btfsc UP                              ; if UP gets released, exit
retlw .5
call  GPIO_TestDOWN                 ; make GP0/DECR/CS an input (w/pu enabled)
movlw .5                              ; 5ms delay
call  VAR1000TcyDELAY
btfsc DOWN                          ; if DOWN gets released, exit
retlw .5
decfsz Exit,f
goto  Loop5_2sec
call  InitGPIO                        ; make GP0/DECR/CS & GP1/INCR/UD outputs, block undesired U/D commands
movlw .64
call  HV_Increment_WL_Disable
; movlw .4
; call  VAR1000TcyDELAY ; add a 4mS delay for E/W cycle
HV_IncrExit clrwdt
call  GPIO_TestDOWN                 ; make GP0/DECR/CS an input (w/pu enabled)
movlw .10
call  VAR1000TcyDELAY ; add a 10mS delay for settling time
btfss DOWN                          ; if DOWN gets released, exit
goto  HV_IncrExit
call  GPIO_TestUP                    ; make GP1/INCR/UD an input (w/pu enabled)
movlw .10
call  VAR1000TcyDELAY ; add a 10mS delay for settling time
btfss UP                              ; if UP gets released, exit
goto  HV_IncrExit
clrf  State
retlw .5

State6
movlw .200                            ; 200x10mS = 2s
movwf Exit

Loop6_2sec
call  GPIO_TestUP                    ; make GP1/INCR/UD an input (w/pu enabled)
movlw .5                              ; 5ms delay
call  VAR1000TcyDELAY
btfsc UP                              ; if UP gets released, exit
retlw .6
call  GPIO_TestDOWN                 ; make GP0/DECR/CS an input (w/pu enabled)
movlw .5                              ; 5ms delay
call  VAR1000TcyDELAY
btfsc DOWN                          ; if DOWN gets released, exit
retlw .6
decfsz Exit,f
goto  Loop6_2sec
call  InitGPIO                        ; make GP0/DECR/CS & GP1/INCR/UD outputs, block undesired U/D commands
movlw .64
call  HV_Decrement_WL_Disable
; movlw .4
; call  VAR1000TcyDELAY ; add a 4mS delay for E/W cycle
```

00066_MCP402XEV.ASM Source Code

TABLE E-1: 00066_MCP402XEV.ASM SOURCE CODE (CONTINUED)

```
HV_DecrExit  clrwdt
             call    GPIO_TestUP      ; make GP1/INCR/UD an input (w/pu enabled)
             movlw   .10
             call    VAR1000TcyDELAY  ; add a 10ms delay for settling time
             btfss  UP                ; if UP gets released, exit
             goto    HV_DecrExit
             call    GPIO_TestDOWN    ; make GP0/DECR/CS an input (w/pu enabled)
             movlw   .10
             call    VAR1000TcyDELAY  ; add a 10ms delay for settling time
             btfss  DOWN              ; if DOWN gets released, exit
             goto    HV_DecrExit
             clrf   State
             retlw   .6

State7
State8
State9
State10
State11      ; HV Increment w/o WL
             call    InitGPIO         ; make GP0/DECR/CS & GP1/INCR/UD outputs, block undesired U/D commands
             movlw   .1
             call    HV_Increment_WL_Disable
             clrf   State
             retlw   .11

State12      ; HV Increment w/o WL
             call    InitGPIO         ; make GP0/DECR/CS & GP1/INCR/UD outputs, block undesired U/D commands
             movlw   .1
             call    HV_Decrement_WL_Disable
             clrf   State
             retlw   .12

State13      ; HV Decrement w/WL
             call    InitGPIO         ; make GP0/DECR/CS & GP1/INCR/UD outputs, block undesired U/D commands
             call    HV_Increment_WL_Enable
             clrf   State
             retlw   .13

State14      ; HV Decrement w/WL
             call    InitGPIO         ; make GP0/DECR/CS & GP1/INCR/UD outputs, block undesired U/D commands
             call    HV_Decrement_WL_Enable
             clrf   State
             retlw   .14

State15
             goto    StateMachineReset

;*****
; Low Power Mode
;*****
LowPowerMode
             movlw   b'11111000'      ; make all I/O pins an output
             tris   GPIO
             movlw   b'11111111'
             movwf  GPIO              ; output high
             movlw   b'10011111'      ; disable Wake-Up on Pin Change,
                                     ; enable weak pullups for button inputs
                                     ; TOCS must be 0 for GP2 TRIS to be active
                                     ; set up for 2.3ms WDT

             option
             sleep                    ; put into lowest power setting
             goto    Start            ; shouldn't get here

SUBS      CODE
```

00066_MCP402XEV.ASM Source Code

TABLE E-1: 00066_MCP402XEV.ASM SOURCE CODE (CONTINUED)

```

;*****
; State Machine Subroutines
;*****
DetermineState
    swapf    State,f
    rrf     State,f
    rrf     State,w
    andlw   b'00111111'    ; mask invalid states
    addwf   PCL,f
S0_00    retlw   .0        ; both buttons pressed at same time, shouldn't be here
S0_01    retlw   .1        ; UP button pressed, change state
S0_10    retlw   .2        ; DOWN button pressed, change state
S0_11    retlw   .0        ; no change
S1_00    retlw   .5        ; both buttons pressed, change state
S1_01    retlw   .1        ; no change
S1_10    retlw   .0        ; shouldn't be here, reset state
S1_11    retlw   .3        ; UP button released, change state
S2_00    retlw   .6        ; both buttons pressed, change state
S2_01    retlw   .0        ; shouldn't be here, reset state
S2_10    retlw   .2        ; no change
S2_11    retlw   .4        ; DOWN button released, change state
S3_00    retlw   .0        ; shouldn't be here, reset state
S3_01    retlw   .0        ; shouldn't be here, reset state
S3_10    retlw   .0        ; shouldn't be here, reset state
S3_11    retlw   .0        ; shouldn't be here, reset state
S4_00    retlw   .0        ; shouldn't be here, reset state
S4_01    retlw   .0        ; shouldn't be here, reset state
S4_10    retlw   .0        ; shouldn't be here, reset state
S4_11    retlw   .0        ; shouldn't be here, reset state
S5_00    retlw   .5        ; no change
S5_01    retlw   .7        ; DOWN button released, change state
S5_10    retlw   .9        ; UP button released, change state
S5_11    retlw   .0        ; shouldn't be here, reset state
S6_00    retlw   .6        ; no change
S6_01    retlw   .10       ; DOWN button released
S6_10    retlw   .8        ; UP button released
S6_11    retlw   .0        ; shouldn't be here, reset state
S7_00    retlw   .5        ; both buttons pressed again, change state
S7_01    retlw   .7        ; no change
S7_10    retlw   .0        ; shouldn't be here, reset state
S7_11    retlw   .13      ; UP button released, change state
S8_00    retlw   .6        ; both buttons pressed again, change state
S8_01    retlw   .0        ; shouldn't be here, reset state
S8_10    retlw   .8        ; no change
S8_11    retlw   .14      ; DOWN button released, change state
S9_00    retlw   .5        ; both buttons pressed again, change state
S9_01    retlw   .0        ; shouldn't be here, reset state
S9_10    retlw   .9        ; no change
S9_11    retlw   .11      ; DOWN button released, change state
S10_00   retlw   .6        ; both buttons pressed again, change state
S10_01   retlw   .10      ; no change
S10_10   retlw   .0        ; shouldn't be here, reset state
S10_11   retlw   .12      ; DOWN button released, change state
S11_00   retlw   .0        ; shouldn't be here, reset state
S11_01   retlw   .0        ; shouldn't be here, reset state
S11_10   retlw   .0        ; shouldn't be here, reset state
S11_11   retlw   .0        ; shouldn't be here, reset state
S12_00   retlw   .0        ; shouldn't be here, reset state
S12_01   retlw   .0        ; shouldn't be here, reset state
S12_10   retlw   .0        ; shouldn't be here, reset state
S12_11   retlw   .0        ; shouldn't be here, reset state
S13_00   retlw   .0        ; shouldn't be here, reset state
S13_01   retlw   .0        ; shouldn't be here, reset state

```

00066_MCP402XEV.ASM Source Code

TABLE E-1: 00066_MCP402XEV.ASM SOURCE CODE (CONTINUED)

```
S13_10    retlw    .0      ; shouldn't be here, reset state
S13_11    retlw    .0      ; shouldn't be here, reset state
S14_00    retlw    .0      ; shouldn't be here, reset state
S14_01    retlw    .0      ; shouldn't be here, reset state
S14_10    retlw    .0      ; shouldn't be here, reset state
S14_11    retlw    .0      ; shouldn't be here, reset state
S15_00    retlw    .0      ; shouldn't be here, reset state
S15_01    retlw    .0      ; shouldn't be here, reset state
S15_10    retlw    .0      ; shouldn't be here, reset state
S15_11    retlw    .0      ; shouldn't be here, reset state

PerformState
    movf    State,w
    andlw   b'00001111'    ; mask all states >15
    addwf   PCL,f          ; jump to desired State
    retlw   .0             ; State 0, no action
    goto    State1         ; (2s for repeating LV increment)
    goto    State2         ; (2s for repeating LV decrement)
    goto    State3
    goto    State4
    goto    State5         ; (2s for repeating HV increment)
    goto    State6         ; (2s for repeating HV decrement)
    retlw   .7             ; State 7, no action
    retlw   .8             ; State 8, no action
    retlw   .9             ; State 9, no action
    retlw   .10            ; State 10, no action
    goto    State11
    goto    State12
    goto    State13
    goto    State14
    goto    StateMachineReset ; State 15... shouldn't be here

;*****
InitGPIO
    movlw   b'00001011'    ; initialize UP and DOWN switches to be high & CP to be low.
    movwf   GPIO
    movlw   b'11111100'    ; make GP0/DECR/CS & GP1/INCR/UD outputs, block undesired U/D commands
    tris    GPIO
    retlw   b'11000000'

GPIO_TestUP
    movlw   b'00001011'    ; initialize UP and DOWN switches to be high & CP to be low.
    movwf   GPIO
    movlw   b'11111100'    ; make both GP0/DECR/CS & GP1/INCR/UD outputs, prevent undesired U/D
commands
    tris    GPIO
    movlw   b'11111110'    ; make GP1/INCR/UD an input (w/pu enabled)
    tris    GPIO
    retlw   b'10000000'

GPIO_TestDOWN
    movlw   b'00001011'    ; initialize UP and DOWN switches to be high & CP to be low.
    movwf   GPIO
    movlw   b'11111100'    ; make both GP0/DECR/CS & GP1/INCR/UD outputs, prevent undesired U/D
commands
    tris    GPIO
    movlw   b'11111101'    ; make GP0/DECR/CS an input (w/pu enabled)
    tris    GPIO
    retlw   b'01000000'
```

00066_MCP402XEV.ASM Source Code

TABLE E-1: 00066_MCP402XEV.ASM SOURCE CODE (CONTINUED)

```
*****  
; Button Isolation Subroutines  
*****  
; Low Voltage Increment & Decrement Subroutines  
*****  
LV_Increment  
    movwf    Exit            ; load the loop counter  
    bsf     UD  
    goto    $+1            ; creates a 3us total delay  
    bcf     CS  
    movlw   .100           ; 5*100 = 500us delay to pull down CS  
    movwf   DLYCNT1  
DLOOP_LVI  
    clrwdt           ;or NOP  
    nop  
    decfsz  DLYCNT1,f  
    goto    DLOOP_LVI  
LV_IncrLoop  
    bcf     UD  
    goto    $+1  
    bsf     UD  
    goto    $+1            ; creates a 3us total delay  
    decfsz  Exit,f        ; Have we incremented the wiper enough?  
    goto    LV_IncrLoop  
IFDEF SaveWiper  
    bcf     UD  
    goto    $+1            ; creates a 3us total delay  
ENDIF  
    bsf     CS  
    retlw   0x00           ; Follow w/long delay to ramp CS & EEPROM Write Cycle  
  
LV_Decrement  
    movwf   Exit            ; load the loop counter  
    bcf     UD  
    goto    $+1            ; creates a 3us total delay  
    bcf     CS  
    movlw   .100           ; 5*100 = 500us delay to pull down CS  
    movwf   DLYCNT1  
DLOOP_LVD  
    clrwdt           ;or NOP  
    nop  
    decfsz  DLYCNT1,f  
    goto    DLOOP_LVD  
IFDEF SaveWiper  
    goto    LV_DecrLoop+4    ; skip first Decrement since final edge is rising  
ENDIF  
LV_DecrLoop  
    bsf     UD  
    goto    $+1            ; creates a 3us total delay  
    bcf     UD  
    goto    $+1            ; creates a 3us total delay  
    decfsz  Exit,f        ; Have we decremented the wiper enough?  
    goto    LV_DecrLoop  
IFDEF SaveWiper  
    bsf     UD  
    goto    $+1            ; creates a 3us total delay  
ENDIF  
    bsf     CS  
    retlw   0x01           ; Follow w/long delay to ramp CS & EEPROM Write Cycle
```

00066_MCP402XEV.ASM Source Code

TABLE E-1: 00066_MCP402XEV.ASM SOURCE CODE (CONTINUED)

```
*****  
; High Voltage Increment & Decrement Subroutines  
*****  
HV_Increment_WL_Disable  
    movwf    Exit                ; load the loop counter  
    bsf     UD  
    goto    $+1                ; creates a 3us total delay  
    bsf     HV_CS                ; starts 1Mhz Charge Pump  
    movlw   .100                ; 5*100 = 500us delay for Charge Pump ramp time  
    movwf   DLYCNT1  
DLOOP_HVI  
    clrwdt   ;or NOP  
    nop  
    decfsz  DLYCNT1,f  
    goto    DLOOP_HVI  
HV_IncrLoop  
    bcf     UD  
    goto    $+1                ; creates a 3us total delay  
    bsf     UD  
    goto    $+1                ; creates a 3us total delay  
    decfsz  Exit,f             ; Have we incremented the wiper enough?  
    goto    HV_IncrLoop  
    bcf     HV_CS                ; shut off 1Mhz Charge Pump  
    bcf     CS                    ; helps pull the signal down from HV  
    goto    $+1  
    bsf     CS  
    retlw   0x02                ; Follow w/long delay to discharge pump & EEPROM Write Cycle  
  
HV_Decrement_WL_Disable  
    movwf    Exit                ; load the loop counter  
    bcf     UD  
    goto    $+1                ; creates a 3us total delay  
    bsf     HV_CS                ; starts 1Mhz Charge Pump  
    movlw   .100                ; 5*100 = 500us delay for Charge Pump ramp time  
    movwf   DLYCNT1  
DLOOP_HVD  
    clrwdt   ;or NOP  
    nop  
    decfsz  DLYCNT1,f  
    goto    DLOOP_HVD  
HV_DecrLoop  
    bsf     UD  
    goto    $+1                ; creates a 3us total delay  
    bcf     UD  
    goto    $+1                ; creates a 3us total delay  
    decfsz  Exit,f             ; Have we decremented the wiper enough?  
    goto    HV_DecrLoop  
    bcf     HV_CS                ; shut off 1Mhz Charge Pump  
    bcf     CS                    ; helps pull the signal down from HV  
    goto    $+1  
    bsf     CS  
    retlw   0x03                ; Follow w/long delay to discharge pump & EEPROM Write Cycle  
  
HV_Increment_WL_Enable  
    bsf     UD  
    goto    $+1                ; creates a 3us total delay  
    bsf     HV_CS                ; starts 1Mhz Charge Pump  
    movlw   .100                ; 5*100 = 500us delay for Charge Pump ramp time  
    movwf   DLYCNT1
```

00066_MCP402XEV.ASM Source Code

TABLE E-1: 00066_MCP402XEV.ASM SOURCE CODE (CONTINUED)

```

DLOOP_HVIWL
    clrwdt    ;or NOP
    nop
    decfsz   DLYCNT1,f
    goto     DLOOP_HVIWL
    bcf      UD
    goto     $+1          ; creates a 3us total delay
    bsf      UD
    goto     $+1          ; creates a 3us total delay
    bcf      UD
    goto     $+1          ; creates a 3us total delay
    bcf      HV_CS       ; shut off 1Mhz Charge Pump
    bcf      CS          ; helps pull the signal down from HV
    goto     $+1
    bsf      CS
    retlw    0x04        ; Follow w/long delay to discharge pump & EEPROM Write Cycle

HV_Decrement_WL_Enable
    bcf      UD
    bsf      CS
    goto     $+1          ; creates a 3us total delay
    bsf      HV_CS       ; starts 1Mhz Charge Pump
    movlw   .100         ; 5*100 = 500us delay for Charge Pump ramp time
    movwf   DLYCNT1

DLOOP_HVDWL
    clrwdt    ;or NOP
    nop
    decfsz   DLYCNT1,f
    goto     DLOOP_HVDWL
    bcf      UD
    goto     $+1          ; creates a 3us total delay
    bcf      HV_CS       ; shut off 1Mhz Charge Pump
    bcf      CS          ; helps pull the signal down from HV
    goto     $+1
    bsf      CS
    retlw    0x05        ; Follow w/long delay to discharge pump & EEPROM Write Cycle
;*****
; VARIABLE DELAY SUBROUTINES
;*****
;   DLYCNT1 = F9h = 249d   DLYCNT2 = W
;   DELAY = T((4 DLYCNT1 + 4) DLYCNT2 + 4)
;
; ex. To create a 300ms delay when using a 4Mhz osc, 300-250 = 50
;   movlw .50 ;load .50 into WREG
;   call VAR1000TcyDELAY ;call VAR1000TcyDELAY = 50ms delay w/4MHz Osc
;   call VAR1000TcyDELAY ;call VAR1000TcyDELAY = 250ms delay w/4MHz Osc
;   ;total = 300ms delay
;*****
; The value in W at the time of the CALL = x. Delay = 1000Tcy*x
VAR1000TcyDELAY
    movwf   DLYCNT2      ; LOADS CONTROLLING DLY # INTO PRIMARY COUNTER
DLOOP2
    movlw   .249         ; MAXIMIZES THE SECONDARY DLY COUNTER
    movwf   DLYCNT1
DLOOP1
    clrwdt    ;or NOP
    decfsz   DLYCNT1,f   ; DECREMENT AND TEST SECONDARY LOOP FOR ZERO
    goto     DLOOP1     ; CONTINUE SECONDARY LOOP
    decfsz   DLYCNT2,f   ; DECREMENT AND TEST PRIMARY DLY COUNTER
    goto     DLOOP2     ; CONTINUE PRIMARY LOOP
    retlw    .250       ; preload W for the next CALL VAR1000TcyDELAY

```

00066_MCP402XEV.ASM Source Code

TABLE E-1: 00066_MCP402XEV.ASM SOURCE CODE (CONTINUED)

```
;*****
;   VARIABLE 5 Tcy DELAY UP TO 256*5Tcy+5Tcy
;   DLYCNT1 = W
;   DELAY = T(1 + 5 DLYCNT1 - 1) + CALL + RETLW
;
; ex. To create a 250us delay, (250/5)-1 = 49
;   movlw .49      ;load .49 into WREG
;   call  VAR5TcyDELAY ;call VAR5TcyDELAY
;*****
; The value in W at the time of the CALL = x. Delay = 5*Tcy + 5Tcy
VAR5TcyDELAY
    movwf  DLYCNT1      ; LOADS CONTROLLING DLY # INTO PRIMARY COUNTER
DLOOP3  clrwdt      ;or NOP
        nop
        decfsz DLYCNT1,f      ; DECREMENT AND TEST ZERO
        goto  DLOOP3      ; CONTINUE LOOP
        retlw .250      ; preload W for the next CALL VAR5TcyDELAY
;*****
end
```



WORLDWIDE SALES AND SERVICE

AMERICAS

Corporate Office

2355 West Chandler Blvd.
Chandler, AZ 85224-6199
Tel: 480-792-7200
Fax: 480-792-7277
Technical Support:
<http://support.microchip.com>
Web Address:
www.microchip.com

Atlanta

Alpharetta, GA
Tel: 770-640-0034
Fax: 770-640-0307

Boston

Westborough, MA
Tel: 774-760-0087
Fax: 774-760-0088

Chicago

Itasca, IL
Tel: 630-285-0071
Fax: 630-285-0075

Dallas

Addison, TX
Tel: 972-818-7423
Fax: 972-818-2924

Detroit

Farmington Hills, MI
Tel: 248-538-2250
Fax: 248-538-2260

Kokomo

Kokomo, IN
Tel: 765-864-8360
Fax: 765-864-8387

Los Angeles

Mission Viejo, CA
Tel: 949-462-9523
Fax: 949-462-9608

San Jose

Mountain View, CA
Tel: 650-215-1444
Fax: 650-961-0286

Toronto

Mississauga, Ontario,
Canada
Tel: 905-673-0699
Fax: 905-673-6509

ASIA/PACIFIC

Australia - Sydney

Tel: 61-2-9868-6733
Fax: 61-2-9868-6755

China - Beijing

Tel: 86-10-8528-2100
Fax: 86-10-8528-2104

China - Chengdu

Tel: 86-28-8676-6200
Fax: 86-28-8676-6599

China - Fuzhou

Tel: 86-591-8750-3506
Fax: 86-591-8750-3521

China - Hong Kong SAR

Tel: 852-2401-1200
Fax: 852-2401-3431

China - Qingdao

Tel: 86-532-8502-7355
Fax: 86-532-8502-7205

China - Shanghai

Tel: 86-21-5407-5533
Fax: 86-21-5407-5066

China - Shenyang

Tel: 86-24-2334-2829
Fax: 86-24-2334-2393

China - Shenzhen

Tel: 86-755-8203-2660
Fax: 86-755-8203-1760

China - Shunde

Tel: 86-757-2839-5507
Fax: 86-757-2839-5571

China - Wuhan

Tel: 86-27-5980-5300
Fax: 86-27-5980-5118

China - Xian

Tel: 86-29-8833-7250
Fax: 86-29-8833-7256

ASIA/PACIFIC

India - Bangalore

Tel: 91-80-2229-0061
Fax: 91-80-2229-0062

India - New Delhi

Tel: 91-11-5160-8631
Fax: 91-11-5160-8632

India - Pune

Tel: 91-20-2566-1512
Fax: 91-20-2566-1513

Japan - Yokohama

Tel: 81-45-471-6166
Fax: 81-45-471-6122

Korea - Gumi

Tel: 82-54-473-4301
Fax: 82-54-473-4302

Korea - Seoul

Tel: 82-2-554-7200
Fax: 82-2-558-5932 or
82-2-558-5934

Malaysia - Penang

Tel: 60-4-646-8870
Fax: 60-4-646-5086

Philippines - Manila

Tel: 63-2-634-9065
Fax: 63-2-634-9069

Singapore

Tel: 65-6334-8870
Fax: 65-6334-8850

Taiwan - Hsin Chu

Tel: 886-3-572-9526
Fax: 886-3-572-6459

Taiwan - Kaohsiung

Tel: 886-7-536-4818
Fax: 886-7-536-4803

Taiwan - Taipei

Tel: 886-2-2500-6610
Fax: 886-2-2508-0102

Thailand - Bangkok

Tel: 66-2-694-1351
Fax: 66-2-694-1350

EUROPE

Austria - Wels

Tel: 43-7242-2244-399
Fax: 43-7242-2244-393

Denmark - Copenhagen

Tel: 45-4450-2828
Fax: 45-4485-2829

France - Paris

Tel: 33-1-69-53-63-20
Fax: 33-1-69-30-90-79

Germany - Munich

Tel: 49-89-627-144-0
Fax: 49-89-627-144-44

Italy - Milan

Tel: 39-0331-742611
Fax: 39-0331-466781

Netherlands - Drunen

Tel: 31-416-690399
Fax: 31-416-690340

Spain - Madrid

Tel: 34-91-708-08-90
Fax: 34-91-708-08-91

UK - Wokingham

Tel: 44-118-921-5869
Fax: 44-118-921-5820

10/31/05



Стандарт Электрон Связь

Мы молодая и активно развивающаяся компания в области поставок электронных компонентов. Мы поставляем электронные компоненты отечественного и импортного производства напрямую от производителей и с крупнейших складов мира.

Благодаря сотрудничеству с мировыми поставщиками мы осуществляем комплексные и плановые поставки широчайшего спектра электронных компонентов.

Собственная эффективная логистика и склад в обеспечивает надежную поставку продукции в точно указанные сроки по всей России.

Мы осуществляем техническую поддержку нашим клиентам и предпродажную проверку качества продукции. На все поставляемые продукты мы предоставляем гарантию .

Осуществляем поставки продукции под контролем ВП МО РФ на предприятия военно-промышленного комплекса России , а также работаем в рамках 275 ФЗ с открытием отдельных счетов в уполномоченном банке. Система менеджмента качества компании соответствует требованиям ГОСТ ISO 9001.

Минимальные сроки поставки, гибкие цены, неограниченный ассортимент и индивидуальный подход к клиентам являются основой для выстраивания долгосрочного и эффективного сотрудничества с предприятиями радиоэлектронной промышленности, предприятиями ВПК и научно-исследовательскими институтами России.

С нами вы становитесь еще успешнее!

Наши контакты:

Телефон: +7 812 627 14 35

Электронная почта: sales@st-electron.ru

Адрес: 198099, Санкт-Петербург,
Промышленная ул, дом № 19, литера Н,
помещение 100-Н Офис 331