

MAX1231B/MAX11633/MAX11635 Evaluation Systems

Evaluate: MAX1030/MAX1031/MAX1230/ MAX1231/MAX11624/MAX11625/ MAX11632-MAX11635/MAX11642/MAX11643

General Description

The MAX1231B/MAX11633/MAX11635 evaluation systems (EV systems) include one master board and one of three daughter boards. The EV systems also include Windows XP®, Windows Vista®, and Windows® 7-compatible software that provides a simple graphical user interface (GUI) for exercising the features of the various ADCs. The master board (MAX116XXSPIMB) connects to a PC's USB port and allows the transfer of SPI commands to the corresponding daughter board.

The daughter boards are fully assembled and tested PCBs that demonstrate the capabilities of the MAX1030, MAX1031, MAX1230, MAX1231, MAX11624, MAX11625, MAX11632-MAX11635, MAX11642, and MAX11643 300ksps, 8-/10-/12-bit, 3V/5V, low-power, high-speed SPI ADCs with internal or external references.

Each EV kit daughter board evaluates different ADCs, but only the default ADC referenced in the EV kit daughter board is installed on the board. Contact the factory for free samples of the other pin-compatible ADCs to evaluate these devices or to order individual boards.

Features

- ◆ USB Powered (No External Power Supply Required)
- ◆ Daughter Board Powered by the Master Board
- ◆ 4/16 ADC Channel Inputs
- ◆ 10MHz SPI Interface
- ◆ Windows XP-, Windows Vista-, and Windows 7-Compatible Software
- ◆ Time Domain, Frequency Domain, and Histogram Plotting in the EV System Software
- ◆ Frequency, RMS, Min, Max, and Average DC Calculations in the EV System Software
- ◆ Collects Up to One Million Samples
- ◆ On-Board Voltage Reference
- ◆ Proven PCB Layout
- ◆ Fully Assembled and Tested

[Ordering Information/Selector Guide](#) appears at end of data sheet.

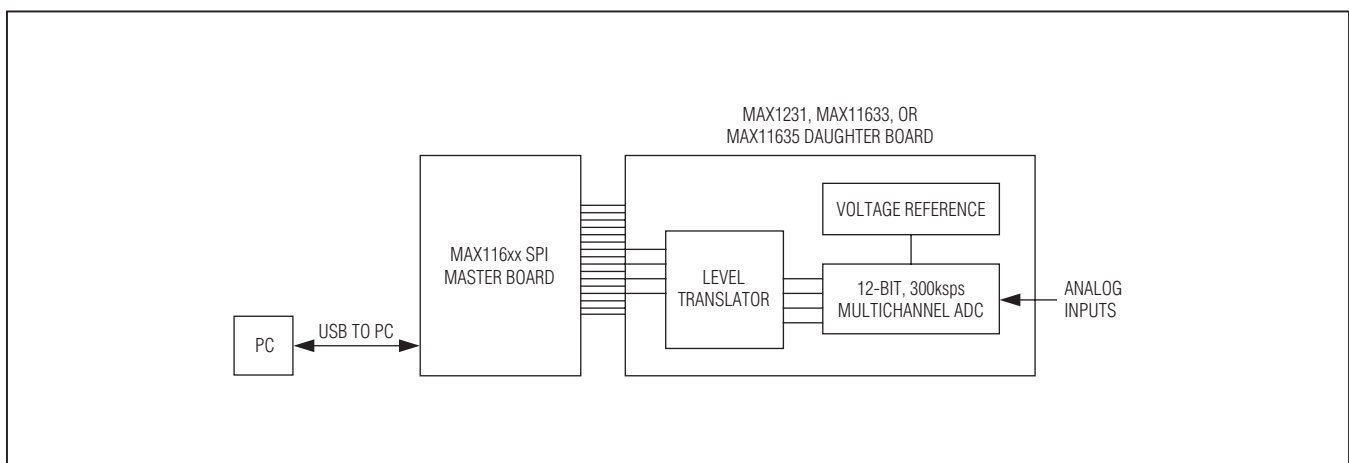

Figure 1. EV System Block Diagram

Windows, Windows XP, and Windows Vista are registered trademarks of Microsoft Corp.

MAX1231B/MAX11633/MAX11635 Evaluation Systems

Evaluate: MAX1030/MAX1031/MAX1230/ MAX1231/MAX11624/MAX11625/ MAX11632-MAX11635/MAX11642/MAX11643

Component Lists

MAX116XX SPI Master Board

DESIGNATION	QTY	DESCRIPTION
C1-C17	17	47nF ±10%, 16V, X7R ceramic capacitors (0603) Murata GRM188R71C473K
C18-C33	16	1nF ±10%, 50V, X7R ceramic capacitors (0603) Murata GRM188R71H102K
C34, C52	2	1µF ±10%, 16V X5R ceramic capacitors (0603) Murata GRM188R61C105K
C35, C42, C46, C50, C53-C56, C60, C61, C62, C64, C65, C66	14	0.1µF ±10%, 16V X7R ceramic capacitors (0603) TDK C1608X7R1C104K
C36, C39	2	0.01µF ±10%, 50V, X7R ceramic capacitors (0603) Murata GRM188R71H103K
C37, C44, C45	3	10pF ±5%, 50V C0G ceramic capacitors (0603) Murata GRM1885C1H100J
C38	1	15pF ±5%, 50V C0G ceramic capacitor (0603) Murata GRM1885C1H150J
C40, C41	2	39pF ±5%, 50V C0G ceramic capacitors (0603) Murata GRM1885C1H390J
C43, C49, C51, C63, C67, C68, C70	7	10µF ±10%, 25V, X5R ceramic capacitors (1206) Murata GRM31CR61E106K
C47, C48, C69	3	4.7µF ±10%, 25V X5R ceramic capacitors (1206) Murata GRM31CR71E475M
C57	1	0.033µF ±10%, 16V X5R ceramic capacitor (0603) Taiyo Yuden EMK107BJ333KA
C58, C59	2	22pF ±5%, 50V C0G ceramic capacitors (0603) Murata GRM1885C1H220J
C71, C72	2	47µF ±20%, 6.3V capacitors (B1) SANYO 6TPC47MB
DGND, DVDD	2	Uninsulated banana jacks

DESIGNATION	QTY	DESCRIPTION
J1	1	Dual-row, 20-pin (2 x 10) right-angle male header
J2	0	Not installed, dual-row 24-pin (2 x 12) header
J3	1	USB type-B right-angle PC-mount receptacle
JSPI	0	Not installed, 6-pin header
JTAG1	1	6-pin header
JTAG2	1	Dual-row, 10-pin (2 x 5) header
JU1-JU4	0	Not installed, 2-pin headers
JU5	0	Not installed, 3-pin header
JU6-JU9	4	2-pin headers
JU10	1	3-pin header
L1	1	Ferrite bead (0603) TDK MMZ1608R301A
L2	1	22µH, 0.11Ω, 300mA inductor Coilcraft DS1608C-223ML
LED1, LED2, LED3	3	Red LEDs (0603)
R1, R3, R4, R19, R21, R22, R23, R24	8	4.7kΩ ±5% resistors (0603)
R2, R16, R17, R18	4	100Ω ±5% resistors (0603)
R5	1	390Ω ±5% resistor (0603)
R6, R7, R8, R27, R36	5	10kΩ ±5% resistors (0603)
R9, R10, R11	3	200Ω ±5% resistors (0603)
R12, R14, R25, R29	4	10Ω ±5% resistors (0603)
R13	1	150Ω ±5% resistor (0603)
R15	1	56Ω ±5% resistor (0603)
R20, R28	2	680Ω ±5% resistors (0603)
R26	1	1kΩ ±5% resistor (0603)
R30	1	18.7kΩ ±1% resistor (0603)
R31, R43, R44, R46, R50, R53	6	10kΩ ±1% resistors (0603)
R32, R33	2	27Ω ±5% resistors (0603)
R34	1	1.5kΩ ±5% resistor (0603)
R35	1	2.2kΩ ±5% resistor (0603)

MAX1231B/MAX11633/MAX11635 Evaluation Systems

Evaluate: MAX1030/MAX1031/MAX1230/ MAX1231/MAX11624/MAX11625/ MAX11632–MAX11635/MAX11642/MAX11643

Component Lists (continued)

MAX116XX SPI Master Board (continued)

DESIGNATION	QTY	DESCRIPTION
R37–R41	0	Not installed, resistors—short (PC trace)
R42, R45, R51	3	100k Ω \pm 5% resistors (0603)
R47	1	20k Ω \pm 1% resistor (0603)
R48	1	470 Ω \pm 5% resistor (0603)
R49	1	30k Ω \pm 1% resistor (0603)
R52	1	34k Ω \pm 1% resistor (0603)
R54	1	1M Ω \pm 5% resistor (0603)
S1	1	4-position switch
U1	1	Spartan 3A FPGA (144 TQFP) Xilinx XC3S50A-4TQG144I
U2	1	Microcontroller (68 QFN-EP*) Maxim MAXQ2000-RAX+
U3	0	Not installed, Xilinx PROM
U4	1	Atmel SPI Flash (8 SO) Atmel AT45DB161D-SU
U5	1	SRAM (48 TSOP) Cypress CY62167DV30LL-55ZXI
U6, U7, U11	3	LDOs (16 TSSOP-EP*) Maxim MAX1793EUE50+
U8	1	USB-to-UART converter (32 TQFP)

DESIGNATION	QTY	DESCRIPTION
U9	1	93C46-type 3-wire EEPROM (8 SO)
U10	1	LDO (6 SOT23) Maxim MAX1983EUT+
U12	1	Step-up regulator (8 μ MAX®) Maxim MAX1795EUA+
Y1	1	50MHz oscillator
Y2	1	6MHz crystal Hong Kong X'tals SSL60000N1HK188F0-0
Y3	0	Not installed, crystal
Y4	1	16MHz crystal Hong Kong X'tals SSM16000N1HK188F0-0
—	1	USB high-speed A-to-B cables, 6ft
—	5	Shunts
—	1	PCB: MAX116XX SPI MASTER BOARD

*EP = Exposed pad.

MAX1231B EV Kit Daughter Board

DESIGNATION	QTY	DESCRIPTION
AIN0–AIN15	16	Yellow multipurpose test points
C1, C4	2	1 μ F \pm 10%, 10V X5R ceramic capacitors (0402) Murata GRM155R61A105K
C2, C3	2	10 μ F \pm 20%, 6.3V X5R ceramic capacitors (0603) Murata GRM188R60J106M
C5, C6, C7, C12	4	0.1 μ F \pm 10%, 16V X7R ceramic capacitors (0603) Murata GRM188R71C104K
C8–C11, C33	0	Not installed, ceramic capacitors (0603)

DESIGNATION	QTY	DESCRIPTION
C14–C29	16	0.01 μ F \pm 10%, 16V X7R ceramic capacitors (0603) Murata GRM188R71C103K
C30, C31, C32	3	0.1 μ F \pm 10%, 16V X7R ceramic capacitors (0402) Murata GRM155R71C104K
D1	1	Red LED (0603)
GND	3	Black multipurpose test points
J1	1	20-pin (2 x 10) right-angle female header
J2, J3	2	Dual-row, 16-pin (2 x 8) headers
JU1, JU2, JU4	3	3-pin headers
R1	1	470 Ω \pm 5% resistor (0603)
R3–R18	16	10 Ω \pm 5% resistors (0603)
REF+, REF-, VDD	3	Red multipurpose test points

μ MAX is a registered trademark of Maxim Integrated Products, Inc.

MAX1231B/MAX11633/MAX11635 Evaluation Systems

Evaluate: MAX1030/MAX1031/MAX1230/ MAX1231/MAX11624/MAX11625/ MAX11632–MAX11635/MAX11642/MAX11643

Component Lists (continued)

MAX1231B EV Kit Daughter Board (continued)

DESIGNATION	QTY	DESCRIPTION
SW1, SW2	2	8-channel SPST DIP switches
U1	1	12-bit, 16-channel ADC (24 QSOP) Maxim MAX1231BEEG+
U2	1	Voltage reference (8 SO) Maxim MAX6126AASA25+

DESIGNATION	QTY	DESCRIPTION
U3	0	Not installed, voltage reference (8 SO)
U4	1	Level translator (24 TSSOP) Maxim MAX3002EEUP+
—	3	Shunts
—	1	PCB: MAX1231B EVALUATION KIT

MAX11633 EV Kit Daughter Board

DESIGNATION	QTY	DESCRIPTION
AIN0–AIN15	16	Yellow multipurpose test points
C1, C4	2	1 μ F \pm 10%, 10V X5R ceramic capacitors (0402) Murata GRM155R61A105K
C2, C3	2	10 μ F \pm 20%, 6.3V X5R ceramic capacitors (0603) Murata GRM188R60J106M
C5, C6, C7, C12	4	0.1 μ F \pm 10%, 16V X7R ceramic capacitors (0603) Murata GRM188R71C104K
C8–C11	0	Not installed, ceramic capacitors (0603)
C14–C29	16	0.01 μ F \pm 10%, 16V X7R ceramic capacitors (0603) Murata GRM188R71C103K
C30, C31, C32	3	0.1 μ F \pm 10%, 16V X7R ceramic capacitors (0402) Murata GRM155R71C104K
D1	1	Red LED (0603)
GND	2	Black multipurpose test points

DESIGNATION	QTY	DESCRIPTION
J1	1	20-pin (2 x 10) right-angle female header
J2, J3	2	Dual-row, 16-pin (2 x 8) headers
JU1, JU2, JU4	3	3-pin headers
R1	1	470 Ω \pm 5% resistor (0603)
R3–R18	16	10 Ω \pm 5% resistors (0603)
REF, VDD	2	Red multipurpose test points
SW1, SW2	2	8-channel SPST DIP switches
U1	1	12-bit, 16-channel ADC (24 QSOP) Maxim MAX11633EEG+
U2	1	Voltage reference (8 SO) Maxim MAX6126AASA25+
U3	0	Not installed, voltage reference (8 SO)
U4	1	Level translator (24 TSSOP) Maxim MAX3002EEUP+
—	3	Shunts
—	1	PCB: MAX11633 EVALUATION KIT

MAX11635 EV Kit Daughter Board

DESIGNATION	QTY	DESCRIPTION
AIN0–AIN3	4	Yellow multipurpose test points
C1, C4	2	1 μ F \pm 10%, 10V X5R ceramic capacitors (0402) Murata GRM155R61A105K
C2, C3	2	10 μ F \pm 20%, 6.3V X5R ceramic capacitors (0603) Murata GRM188R60J106M

DESIGNATION	QTY	DESCRIPTION
C5, C6, C7, C12, C18	5	0.1 μ F \pm 10%, 16V X7R ceramic capacitors (0603) Murata GRM188R71C104K
C8–C11	0	Not installed, ceramic capacitors (0603)
C14–C17	4	0.01 μ F \pm 10%, 16V X7R ceramic capacitors (0603) Murata GRM188R71C103K

MAX1231B/MAX11633/MAX11635 Evaluation Systems

Evaluate: MAX1030/MAX1031/MAX1230/ MAX1231/MAX11624/MAX11625/ MAX11632-MAX11635/MAX11642/MAX11643

Component Lists (continued)

MAX11635 EV Kit Daughter Board (continued)

DESIGNATION	QTY	DESCRIPTION
C30, C31, C32	3	0.1 μ F \pm 10%, 16V X7R ceramic capacitors (0402) Murata GRM155R71C104K
D1	1	Red LED (0603)
GND	3	Black multipurpose test points
J1	1	20-pin (2 x 10) right-angle female header
J2	1	Dual-row, 16-pin (2 x 8) header
JU1, JU2	2	3-pin headers
JU4	1	2-pin header
R1	1	470 Ω \pm 5% resistor (0603)
R3-R6	4	10 Ω \pm 5% resistors (0603)
REF+, REF-, VDD	3	Red multipurpose test points

DESIGNATION	QTY	DESCRIPTION
SW1	1	8-channel SPST DIP switch
U1	1	12-bit, 4-channel ADC (16 QSOP) Maxim MAX11635EEE+
U2	1	Voltage reference (8 SO) Maxim MAX6126AASA25+
U3	0	Not installed, voltage reference (8 SO)
U4	1	Level translator (24 TSSOP) Maxim MAX3002EEUP+
—	3	Shunts
—	1	PCB: MAX11635 EVALUATION KIT

Component Suppliers

SUPPLIER	PHONE	WEBSITE
Coilcraft, Inc.	847-639-6400	www.coilcraft.com
Hong Kong X'tals Ltd.	852-35112388	www.hongkongcrystal.com
Murata Electronics North America, Inc.	770-436-1300	www.murata-northamerica.com
SANYO Electric Co., Ltd.	619-661-6835	www.sanyo.com
Taiyo Yuden	800-348-2496	www.t-yuden.com
TDK Corp.	847-803-6100	www.component.tdk.com

Note: Indicate that you are using the MAX1231, MAX11633, or MAX11635 when contacting these component suppliers.

MAX1231B/MAX11633/MAX11635 EV System Files

FILE	DESCRIPTION
INSTALL.EXE	Installs the EV system files on your computer
MAX116XXSPI.MB.EXE	Application program
CDM20600.EXE	Installs the USB device driver
UNINSTALL.EXE	Uninstalls the EV system software
USB_Driver_Help_200.PDF	USB driver installation help file

MAX1231B/MAX11633/MAX11635 Evaluation Systems

Evaluate: MAX1030/MAX1031/MAX1230/ MAX1231/MAX11624/MAX11625/ MAX11632–MAX11635/MAX11642/MAX11643

Quick Start

Required Equipment

- MAX1231B, MAX11633, or MAX11635 EV system
- MAX116XX SPI master board (USB cable included)
- One of the three EV kit daughter boards
- Function generator
- Windows XP, Windows Vista, or Windows 7 PC with a spare USB port

Note: In the following sections, software-related items are identified by bolding. Text in **bold** refers to items directly from the EV system software. Text in **bold and underlined** refers to items from the Windows operating system.

Procedure

Each EV system is fully assembled and tested. Follow the steps below to verify board operation:

- 1) Visit www.maxim-ic.com/evkitsoftware to download the latest version of the EV system software, 116XXSPIMBRxx.ZIP. Save the EV system software to a temporary folder and uncompress the ZIP file.
- 2) Install the EV system software and USB driver on your computer by running the INSTALL.EXE program inside the temporary folder. The program files are copied to your PC and icons are created in the Windows **Start | Programs** menu. During software installation, some versions of Windows may show a warning message indicating that this software is from an unknown publisher. This is not an error condition and it is safe to proceed with installation. Administrator privileges are required to install the USB device driver on Windows.
- 3) Carefully connect the boards by aligning the daughter board's 20-pin connector with the 20-pin header on the MAX116XX SPI master board. Gently press them together.
- 4) Verify that all jumpers are in their default positions for the master board (Table 1) and the jumpers for the selected EV kit daughter board (Tables 2, 3, and 4).
- 5) Connect the positive terminal of the signal generator to the AIN0 connector on the EV kit daughter board. Connect the negative terminal of the signal generator to the GND connector on the EV kit daughter board.
- 6) Enable the signal generator. Set the signal source to generate a 1kHz, 1V_{p-p} sinusoidal wave with 1V offset.
- 7) Connect the USB cable from the PC to the master board. A Windows message appears when connecting the master board to the PC for the first time. Each version of Windows has a slightly different message. If you see a Windows message stating **ready to use**, then proceed to the next step. Otherwise, open the **USB_Driver_Help_200.PDF** document in the Windows **Start | Programs** menu to verify that the USB driver was installed successfully.
- 8) Start the MAX116XX SPI EV system software by opening its icon in the **Start | Programs** menu. The EV system software device selection window appears, as shown in Figure 2. Select the appropriate device from the **Select the ADC device** drop-down list. The EV system software main window appears, as shown in Figure 3.
- 9) Select **2048** from the **Number of Samples** drop-down list in the **Data Logging** group box.
- 10) Enter **300** into the **Sample Rate (ksps)** edit box to set the maximum sampling rate.
- 11) Check the **Remove DC** checkbox to remove the DC component of the sampled data.
- 12) Press the **Start Conversion** button.
- 13) Verify the **Frequency** of approximately 1kHz, the **RMS** value of 1.06V, the **MIN** value of 0.50V, the **MAX** value of 1.50V, and the **Avg DC** value of 1V are displayed in the **Calculation** group box.

MAX1231B/MAX11633/MAX11635 Evaluation Systems

Evaluate: MAX1030/MAX1031/MAX1230/ MAX1231/MAX11624/MAX11625/ MAX11632-MAX11635/MAX11642/MAX11643

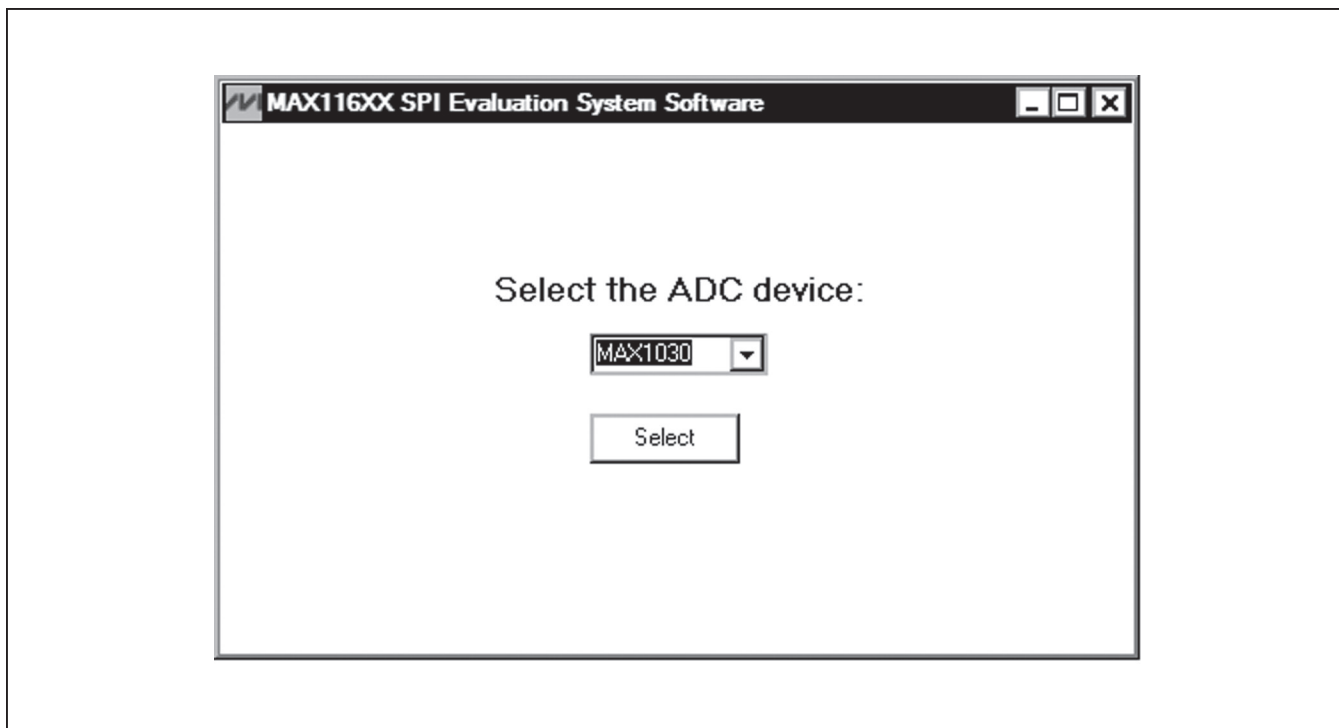

Figure 2. MAX116XX SPI EV System Software Device Selection Window

Detailed Description of Software

The MAX116XX SPI EV system software supports the MAX1231/MAX11633/MAX11635 family of ADC devices. When the EV system software starts up, select the appropriate device from the **Select the ADC device** drop-down list shown in Figure 2. Press the **Select** button to bring up the main software window.

The main window of the evaluation software (Figure 3) contains a **Device Configuration** group box, a **Data Logging** group box, and four tab sheets to display the sampled data.

Device Configuration

The **Device Configuration** group box is used to configure the selected ADC device.

Use the drop-down list in the **Ref Voltage and AIN_/REF Setting** group box to select the source of the voltage reference and configure the property of the AIN_/REF pin of the ADC device. If the source of the voltage reference is set to VDD or external reference, enter the actual voltage value in the **Reference Voltage** edit box. This value is used to calculate the voltage from the ADC code.

The drop-down list in the **Channel Select** group box configures the ADC's channel selection register that

determines which analog input channels are to be used for conversion.

In the **Scan Mode** group box, use the drop-down list to select one of the four scan modes. Press the **Info** button to bring up a scanning configuration table for reference (Figure 4).

In the **Averaging Settings** group box, the user can enable the averaging mode, write to the averaging register to configure the ADC to average up to 32 samples for each requested result, and control the number of results requested for single-channel scans.

Select one of the four different clock modes in the **Clock Mode** group box. Press the **Info** button to bring up a clock mode selection table for reference (Figure 5).

All input channels are configurable for single-ended or differential inputs in unipolar or bipolar mode. The user can configure the input channels in the **Input Type** group box. If the selected ADC device has an internal temperature sensor, check the **Temperature Measurement** checkbox to enable the temperature reading.

Press the **Reset All Registers** button to reset the ADC registers to their default settings. Press the **Clear FIFO** button to clear the ADC FIFO buffer.

MAX1231B/MAX11633/MAX11635 Evaluation Systems

Evaluate: MAX1030/MAX1031/MAX1230/ MAX1231/MAX11624/MAX11625/ MAX11632-MAX11635/MAX11642/MAX11643

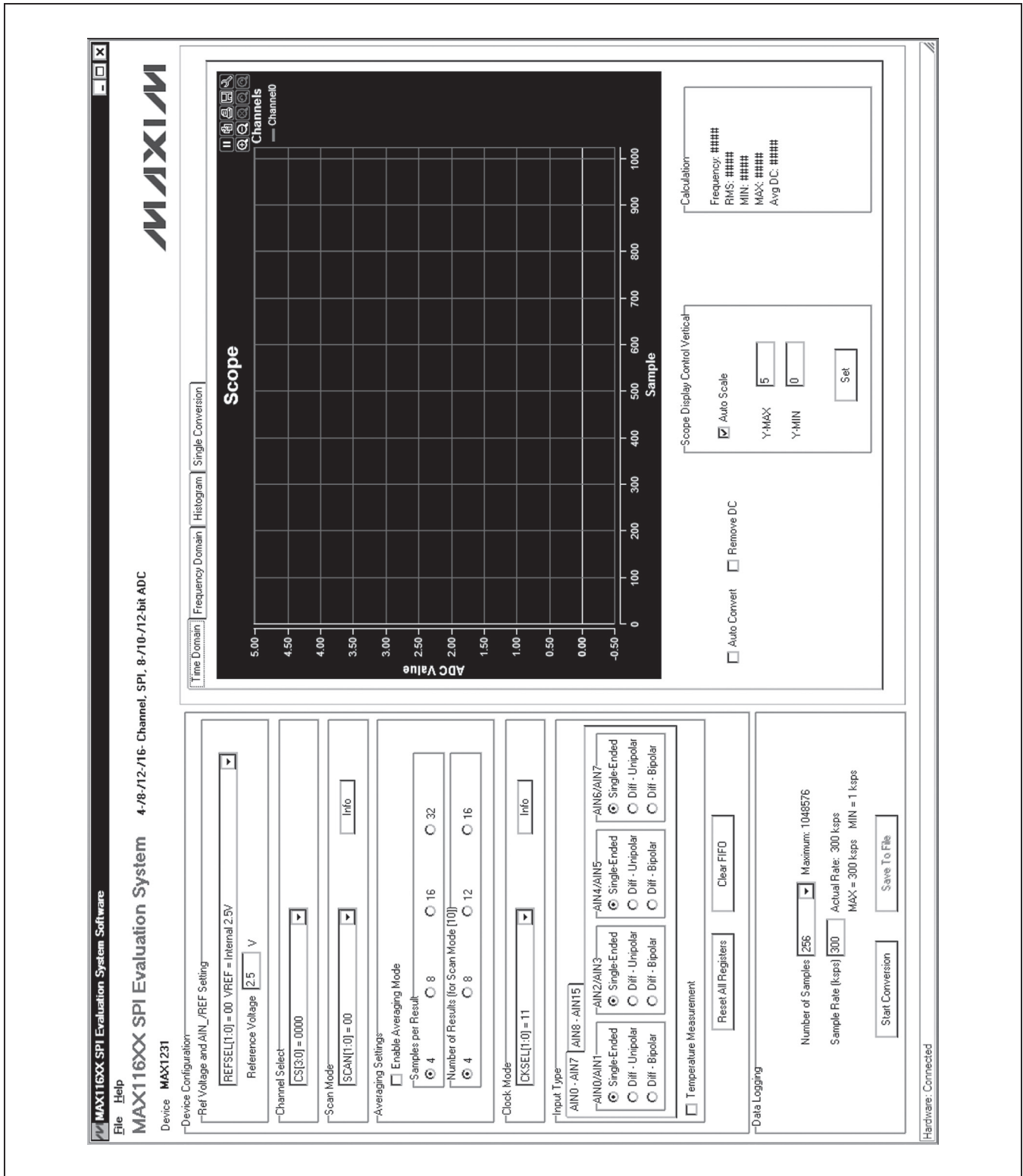

Figure 3. MAX116XX SPI EV System Software Main Window

MAX1231B/MAX11633/MAX11635 Evaluation Systems

Evaluate: MAX1030/MAX1031/MAX1230/ MAX1231/MAX11624/MAX11625/ MAX11632–MAX11635/MAX11642/MAX11643

SCAN1	SCAN0	SCAN MODE (CHANNEL N IS SELECTED BY BITS CHSEL3–CHSEL0)
0	0	Scans channels 0 through N.
0	1	Scans channels N through the highest numbered channel.
1	0	Scans channel N repeatedly. The averaging register sets the number of results.
1	1	No scan. Converts channel N once only.

Figure 4. Scanning Configuration Reference Table

Data Logging

In the **Data Logging** group box, the user can select the desired number of conversions in the **Number of Samples** drop-down list. Enter the desired sampling rate in the **Sample Rate (ksps)** edit box. The actual sampling rate is displayed at the right of the **Sample Rate (ksps)** edit box. Press the **Start Conversion** button to start sampling. After sampling is finished, the user can save the data to a file by pressing the **Save To File** button. The **Save To File** button is not active until the sampling is done.

Time Domain, Frequency Domain, Histogram, and Single Conversion Tab Sheets

After the **Start Conversion** button in the **Data Logging** group box is pressed, the sampled data in the time domain is plotted in the **Time Domain** tab sheet. The sampled data in the frequency domain is plotted in the **Frequency Domain** tab sheet. The histogram of the sampled signal is plotted in the **Histogram** tab sheet.

The **Single Conversion** tab sheet displays one set of sampled data in any scan mode.

Check the **Auto Convert** checkbox to automatically and repeatedly do the ADC conversions and update the active tab sheet.

Time Domain Tab

In the **Time Domain** tab sheet (Figure 6), check the **Remove DC** check box to remove the DC component of the sampled signal. In the **Scope Display Control Vertical** group box, when the **Auto Scale** checkbox is checked, the software automatically scales the vertical axis in the plot. If the **Auto Scale** checkbox is unchecked, enter the appropriate values into the **Y-MAX** and **Y-MIN** edit boxes and press the **Set** button to set the boundaries for the vertical axis. The software automatically calculates the **Frequency**, **RMS**, **MIN**, **MAX**, and **Avg DC** of the sampled signal and displays the calculated values in the **Calculation** group box. The frequency calculation is valid only when the **Remove DC** checkbox is checked.

MAX1231B/MAX11633/MAX11635 Evaluation Systems
Evaluate: MAX1030/MAX1031/MAX1230/
MAX1231/MAX11624/MAX11625/
MAX11632-MAX11635/MAX11642/MAX11643

CKSEL1	CKSELO	CONVERSION CLOCK	ACQUISITION/SAMPLING	CNVST CONFIGURATION
0	0	Internal	Internally timed	CNVST
0	1	Internal	Externally timed through CNVST	CNVST
1	0	Internal	Internally timed	AIN15/11/7
1	1	External (4.8MHz max)	Externally timed through SCLK	AIN15/11/7

Figure 5. Clock Mode Reference Table

MAX1231B/MAX11633/MAX11635 Evaluation Systems

Evaluate: MAX1030/MAX1031/MAX1230/ MAX1231/MAX11624/MAX11625/ MAX11632–MAX11635/MAX11642/MAX11643

Frequency Domain Tab

The **Frequency Domain** tab sheet (Figure 7) displays the FFT plot of the signal shown in the **Time Domain** tab sheet.

Histogram Tab

The **Histogram** tab sheet (Figure 8) displays the histogram of the signal shown in the **Time Domain** tab sheet. The software automatically calculates the **Mean** and the **Std Dev** (standard deviation, sigma) and displays the calculated values in the **Calculation** group box.

The **Histogram Display Control** radio group box provides three options to scale the horizontal axis on the histogram. The options include **(Mean - 3 sigma) to (Mean + 3 sigma)**, **(Mean - 6 sigma) to (Mean + 6 sigma)**, and **User Define** range.

Single Conversion Tab

The **ADC Value Display for Single Conversion** group box in the **Single Conversion** tab sheet (Figure 9) displays the **ADC Codes** and the calculated **Voltage** values for a single sample of all the channels that associate with the selected scan mode. Pressing the **Start Conversion** button in the **Data Logging** group box updates the status of the **ADC Value Display for Single Conversion** group box. If the **Temperature Measurement** checkbox in the **Input Type** group box is checked, the temperature reading is displayed below the **ADC Value Display for Single Conversion** group box.

Detailed Description of Hardware

MAX1231B/MAX11633/MAX11635 EV System

Each MAX1231B/MAX11633/MAX11635 EV system is a complete data-acquisition system that consists of one master board and three daughter boards. The three daughter boards support the following parts: MAX1030, MAX1031, MAX1230, MAX1231, MAX11624, MAX11625, MAX11632–MAX11635, MAX11642, and MAX11643. The *Ordering Information/Selector Guide* shows the boards that are compatible with different parts.

MAX116XX SPI Master Board

The MAX116XX SPI master board connects to a PC's USB port and allows the transfer of SPI commands to the EV kit daughter board.

Power Supply

By default, the master board is USB powered. The user can apply an external 5V supply to DVDD. The daughter board can be powered by the master board.

EV Kit Daughter Boards

The EV kit daughter boards are fully assembled and tested PCBs that demonstrate the capabilities of the MAX1030, MAX1031, MAX1230, MAX1231, MAX11624, MAX11625, MAX11632–MAX11635, MAX11642, and MAX11643 4-/8-/12-/16-channel, 8-/10-/12-bit, 3V/5V, low-power, high-speed SPI ADCs with internal or external references.

There are three EV kit daughter boards that evaluate the various ADCs. Each daughter board comes with one ADC installed, but other pin-compatible ADCs can be installed by the user. See the *Ordering Information/Selector Guide* section to select the desired EV kit daughter board and ADC.

Carefully connect the EV kit daughter board to the master board by aligning the EV kit daughter board's 20-pin connector (J1) with the 20-pin header (J1) of the master board. Gently press them together.

Voltage Reference

An on-board 2.5V voltage reference (U2) is provided on the EV kit daughter board. U3 is a user-supplied reference and is not installed. To use a user-supplied reference voltage, install U3 with the desired reference voltage and change the shunt on jumper JU2 to the 1-2 position. Alternatively, the user can also supply the reference voltage to the REF+ or REF- test point after removing the shunt from JU2. For more information about the 4.096V reference voltage ADCs, refer to the individual IC data sheet.

Power Supply

By default, the EV kit daughter board is powered from the master board. Jumper JU1 selects between a 5V supply and a 3.6V supply. The output voltage can be monitored on the VDD test point. To use an external power supply, remove the shunt from JU1 and apply user-supplied power to the VDD test point. The power-supply range is between 3.6V and 5.5V.

When evaluating the 5V part, as shown on the *Ordering Information/Selector Guide*, see Tables 2, 3, and 4.

Evaluating the 5V Parts

When evaluating the 5V parts (MAX1030, MAX1230, MAX11624, MAX11632, MAX11634, and MAX11642), see Tables 2, 3, and 4 to properly set jumpers JU1 and JU2.

MAX1231B/MAX11633/MAX11635 Evaluation Systems

Evaluate: MAX1030/MAX1031/MAX1230/ MAX1231/MAX11624/MAX11625/ MAX11632-MAX11635/MAX11642/MAX11643

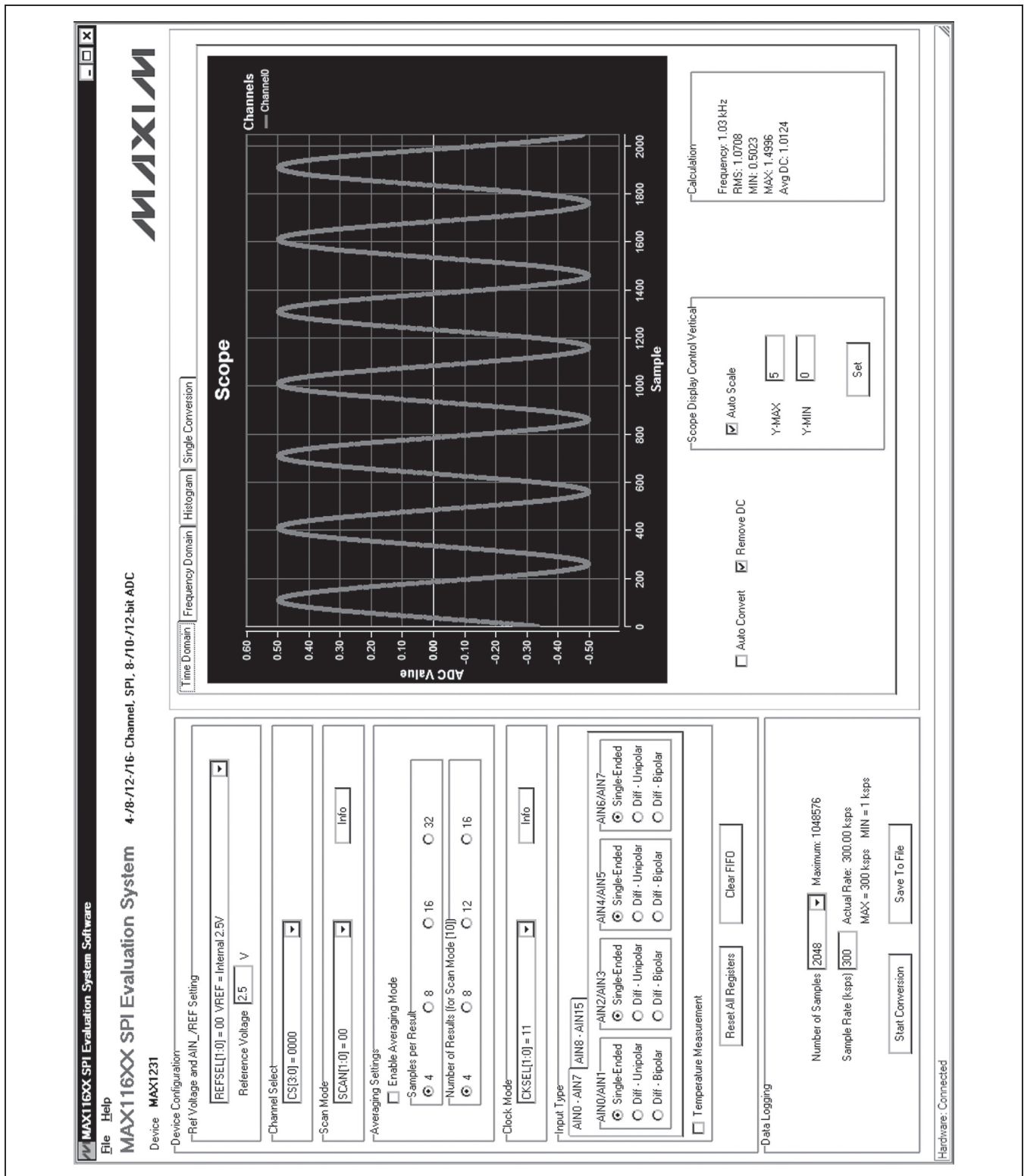

Figure 6. Time Domain Tab

MAX1231B/MAX11633/MAX11635 Evaluation Systems

Evaluate: MAX1030/MAX1031/MAX1230/ MAX1231/MAX11624/MAX11625/ MAX11632-MAX11635/MAX11642/MAX11643

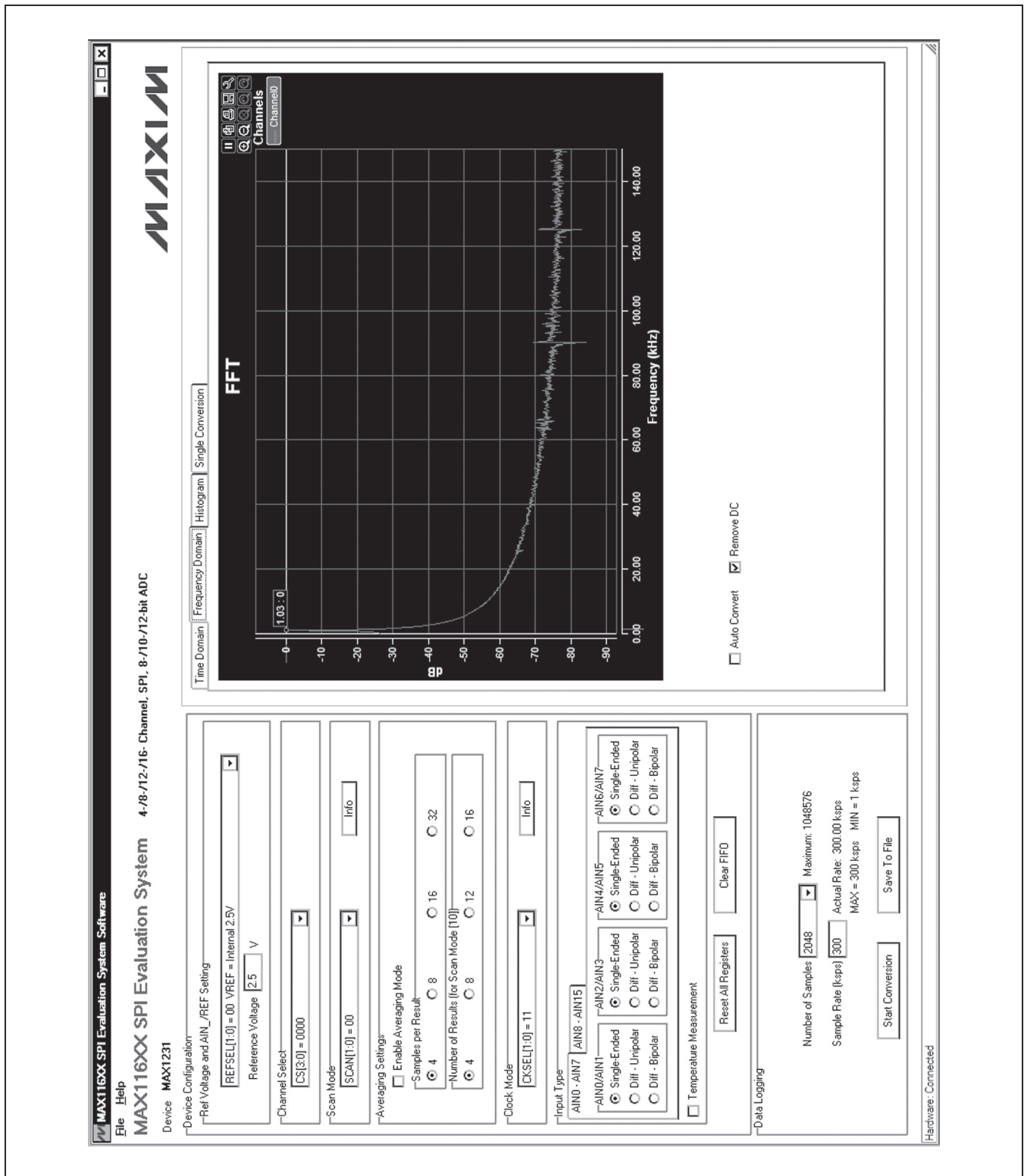

Figure 7. Frequency Domain Tab

MAX1231B/MAX11633/MAX11635 Evaluation Systems

Evaluate: MAX1030/MAX1031/MAX1230/ MAX1231/MAX11624/MAX11625/ MAX11632-MAX11635/MAX11642/MAX11643

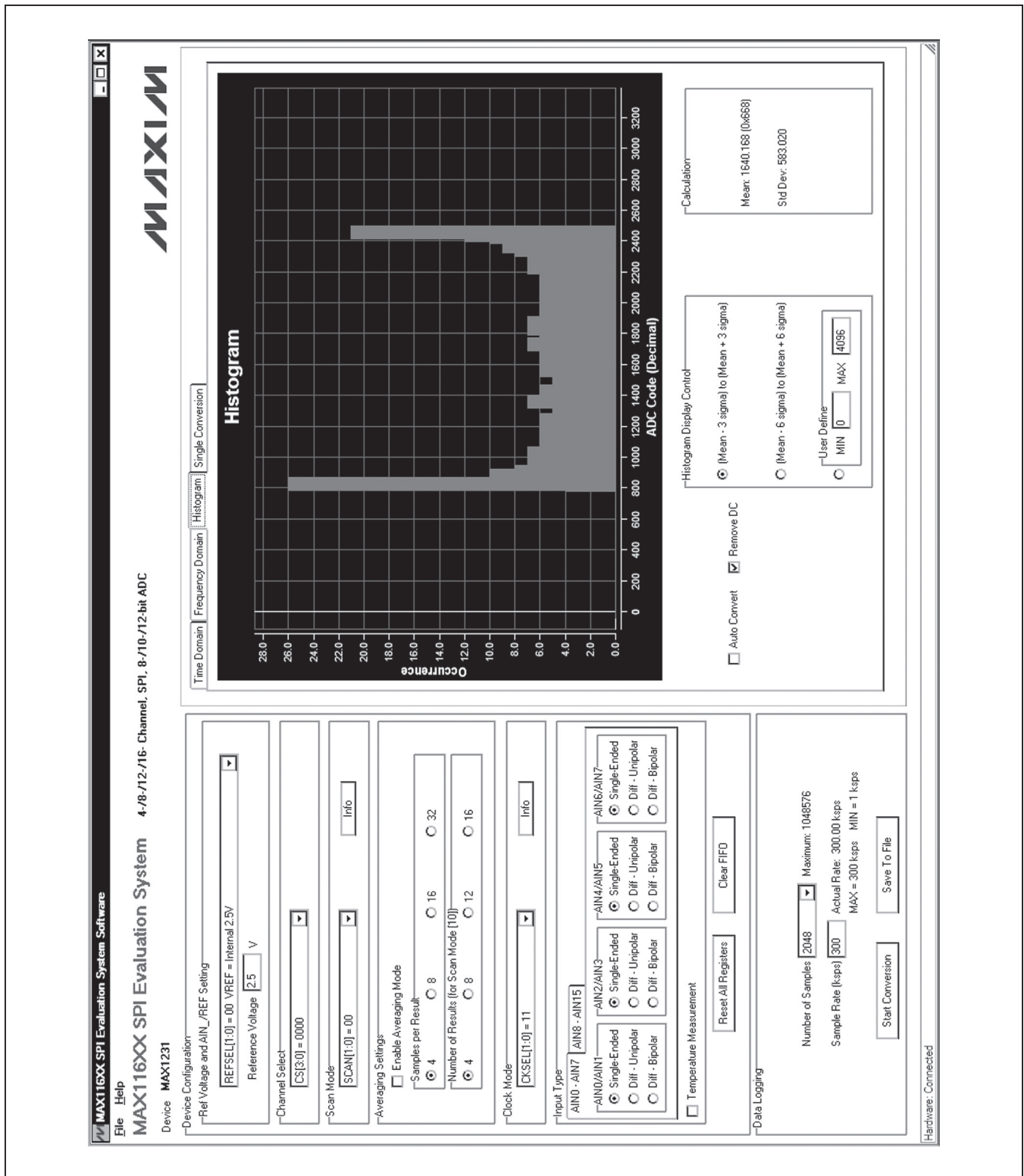

Figure 8. Histogram Tab

MAX1231B/MAX11633/MAX11635 Evaluation Systems

Evaluate: MAX1030/MAX1031/MAX1230/ MAX1231/MAX11624/MAX11625/ MAX11632-MAX11635/MAX11642/MAX11643

MAX116XX SPI Evaluation System Software
File Help
MAX116XX SPI Evaluation System 4-78-/12-/16- Channel, SPI, 8-/10-/12-bit ADC
Device MAX1231

Device Configuration
-Ref Voltage and AIN_n/REF Setting
REFSEL[1:0] = 00 VREF = Internal 2.5V
Reference Voltage 2.5 V

Channel Select
CS[3:0] = 0111

Scan Mode
SCAN[1:0] = 00

Averaging Settings
 Enable Averaging Mode
Samples per Result: 4 8 16 32
Number of Results (for Scan Mode [10]): 4 8 12 16

Clock Mode
CKSEL[1:0] = 00

Input Type
AIN0 - AIN7 AIN8 - AIN15
 AIN0/AIN1 Single-Ended AIN2/AIN3 Single-Ended AIN4/AIN5 Single-Ended AIN6/AIN7 Single-Ended
 AIN0/AIN1 Diff - Unipolar AIN2/AIN3 Diff - Unipolar AIN4/AIN5 Diff - Unipolar AIN6/AIN7 Diff - Unipolar
 AIN0/AIN1 Diff - Bipolar AIN2/AIN3 Diff - Bipolar AIN4/AIN5 Diff - Bipolar AIN6/AIN7 Diff - Bipolar

Temperature Measurement

Reset All Registers Clear FIFO

Data Logging
Number of Samples 556 Maximum: 1048576
Sample Rate (ksps) 300 Actual Rate: 300 ksps
MAX = 300 ksps MIN = 1 ksps
Start Conversion Save To File

MAXIM

Time Domain | Frequency Domain | Histogram | Single Conversion
-ADC Value Display for Single Acquisition

Channel	Code	Voltage
Channel 0	0x8AC	1.3550
Channel 1	0x569	0.8453
Channel 2	0x573	0.8514
Channel 3	0x55C	0.8374
Channel 4	0x58B	0.8661
Channel 5	0x561	0.8405
Channel 6	0x55E	0.8386
Channel 7	0x544	0.8228
Channel 8	0x####	#####
Channel 9	0x####	#####
Channel 10	0x####	#####
Channel 11	0x####	#####
Channel 12	0x####	#####
Channel 13	0x####	#####
Channel 14	0x####	#####
Channel 15	0x####	#####

Auto Convert Temperature: 22.00 °C

Hardware: Connected

Figure 9. Single Conversion Tab

MAX1231B/MAX11633/MAX11635 Evaluation Systems

Evaluate: MAX1030/MAX1031/MAX1230/ MAX1231/MAX11624/MAX11625/ MAX11632–MAX11635/MAX11642/MAX11643

Table 1. Master Board Jumper Settings (JU6–JU10)

JUMPER	SHUNT POSITION	DESCRIPTION
JU6	1-2*	The on-board LDO (U6) provides 3.6V output to the EV system.
	Open	Disconnects the output of the on-board LDO (U6).
JU7	1-2*	The on-board LDO (U7) provides 2.5V output to the EV system.
	Open	Disconnects the output of the on-board LDO (U7).
JU8	1-2*	The on-board LDO (U8) provides 5V output to the EV system.
	2-3	Disconnects the output of the on-board LDO (U8).
JU9	1-2*	The on-board LDO (U9) provides 1.2V output to the EV system.
	Open	Disconnects the output of the on-board LDO (U9).
JU10	1-2*	The EV system is powered by the USB.
	2-3	The EV system is powered by an external power supply. Connect the power supply across the DVDD and DGND connectors.

*Default position.

Table 2. MAX1231B EV Kit Daughter Board Jumper Settings (JU1, JU2, JU4)

JUMPER	SHUNT POSITION	DESCRIPTION
JU1	1-2*	U1 powered by the 3.6V supply from the master board (MAX1031, MAX1231).
	2-3	U1 powered by the 5V supply from the master board (MAX1030, MAX1230).
	Open	Apply the desired supply voltage (3.6V to 5V) on the VDD test point.
JU2	1-2	U3 provides the reference voltage to U1. U3 is not installed by default. For the 5V parts, install a 4.096V reference.
	2-3*	U2 provides a 2.5V reference voltage to U1.
	Open	Apply the desired reference voltage on the REF+ test point.
JU4	1-2	To use $\overline{\text{CNVSTAIN15}}$ as the analog input AIN15.
	2-3*	To use $\overline{\text{CNVSTAIN15}}$ as the digital input $\overline{\text{CNVST}}$.

*Default position.

MAX1231B/MAX11633/MAX11635 Evaluation Systems

Evaluate: MAX1030/MAX1031/MAX1230/ MAX1231/MAX11624/MAX11625/ MAX11632–MAX11635/MAX11642/MAX11643

Table 3. MAX11633 Daughter Board Jumper Settings (JU1, JU2, JU4)

JUMPER	SHUNT POSITION	DESCRIPTION
JU1	1-2*	U1 powered by the 3.6V supply from the master board (MAX11625, MAX11633, and MAX11643).
	2-3	U1 powered by the 5V supply from the master board (MAX11624, MAX11632, and MAX11642).
	Open	Apply the desired supply voltage (3.6V to 5V) on the VDD test point.
JU2	1-2	U3 provides the reference voltage to U1. U3 is not installed by default. For the 5V parts, install a 4.096V reference.
	2-3*	U2 provides a 2.5V reference voltage to U1.
	Open	Apply the desired reference voltage on the REF+ test point.
JU4	1-2	To use $\overline{\text{CNVST}}$ /AIN15 as the analog input AIN15.
	2-3*	To use $\overline{\text{CNVST}}$ /AIN15 as the digital input $\overline{\text{CNVST}}$.

*Default position.

Table 4. MAX11635 Daughter Board Jumper Settings (JU1, JU2, JU4)

JUMPER	SHUNT POSITION	DESCRIPTION
JU1	1-2*	U1 powered by the 3.6V supply from the master board (MAX11635).
	2-3	U1 powered by the 5V supply from the master board (MAX11634).
	Open	Apply the desired supply voltage (3.6V to 5V) on the VDD test point.
JU2	1-2	U3 provides the reference voltage to U1. U3 is not installed by default. For the 5V parts, install a 4.096V reference.
	2-3*	U2 provides a 2.5V reference voltage to U1.
	Open	Apply the desired reference voltage on the REF+ test point.
JU4	Closed*	Connects REF- to GND.
	Open	Externally supply a reference voltage to the REF- test point.

*Default position.

MAX1231B/MAX11633/MAX11635 Evaluation Systems

Evaluate: MAX1030/MAX1031/MAX1230/ MAX1231/MAX11624/MAX11625/ MAX11632-MAX11635/MAX11642/MAX11643

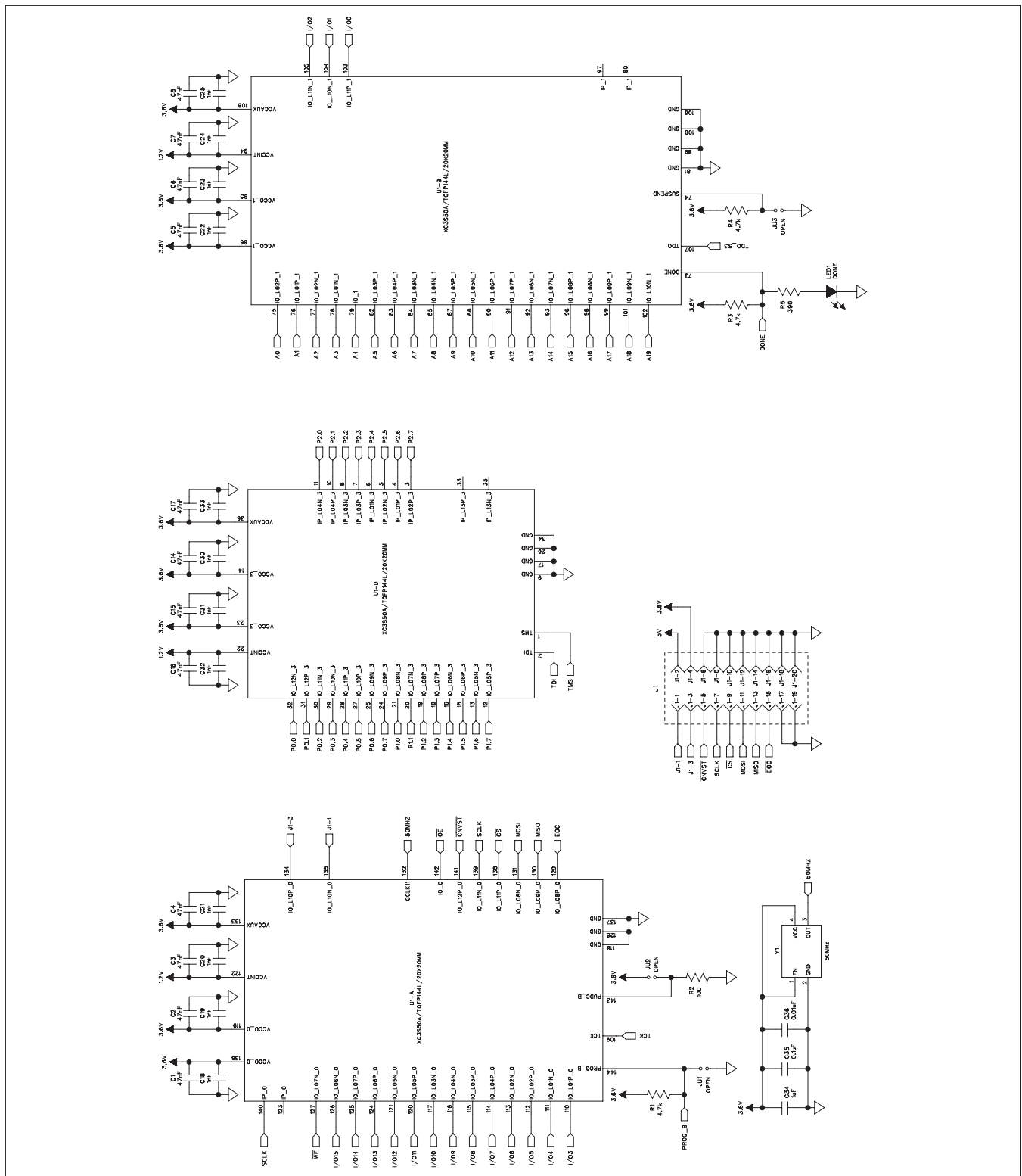

Figure 10a. MAX116XX SPI Master Board Schematic (Sheet 1 of 4)

MAX1231B/MAX11633/MAX11635 Evaluation Systems

Evaluate: MAX1030/MAX1031/MAX1230/ MAX1231/MAX11624/MAX11625/ MAX11632-MAX11635/MAX11642/MAX11643

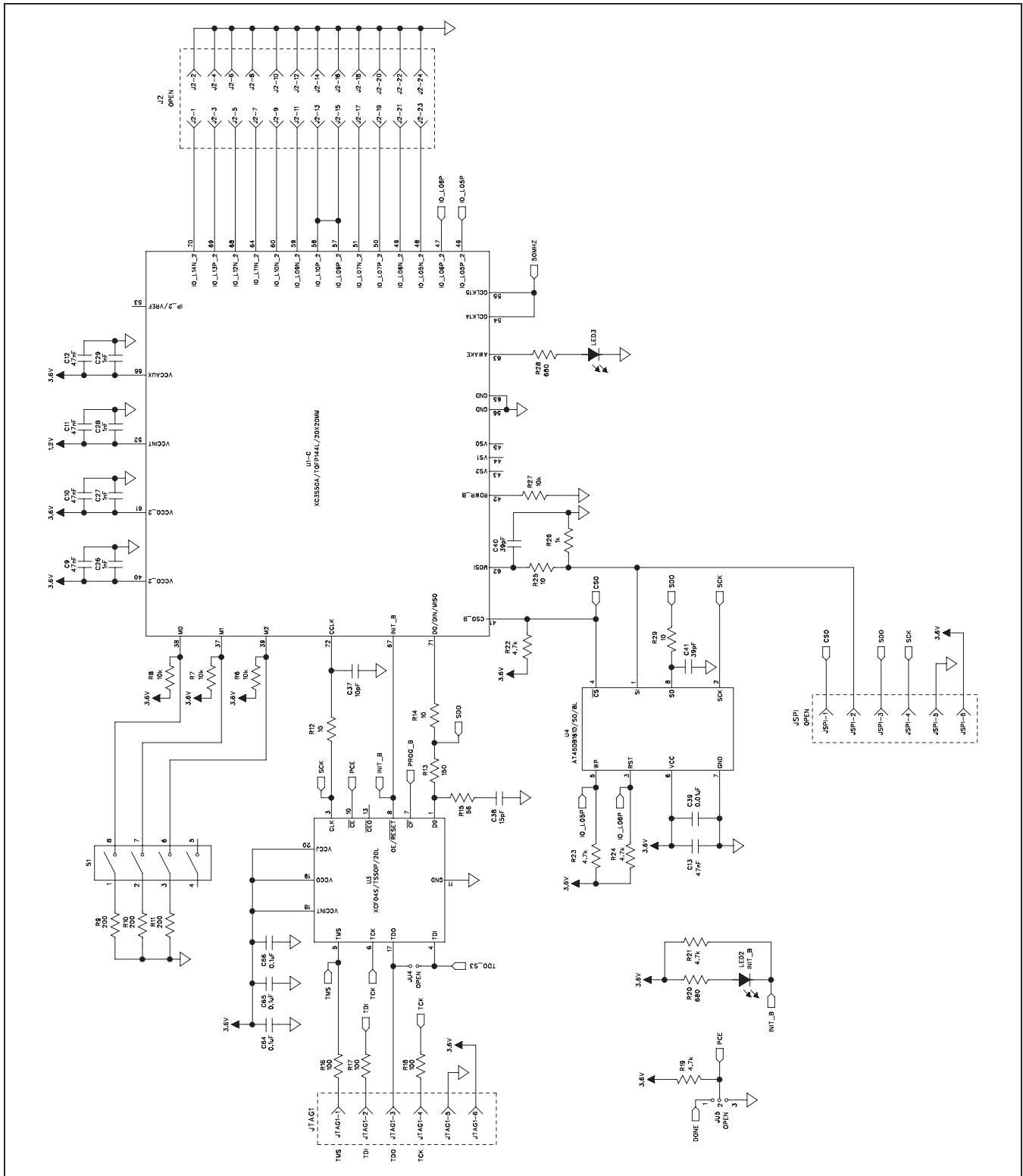

Figure 10b. MAX116XX SPI Master Board Schematic (Sheet 2 of 4)

MAX1231B/MAX11633/MAX11635 Evaluation Systems

Evaluate: MAX1030/MAX1031/MAX1230/ MAX1231/MAX11624/MAX11625/ MAX11632-MAX11635/MAX11642/MAX11643

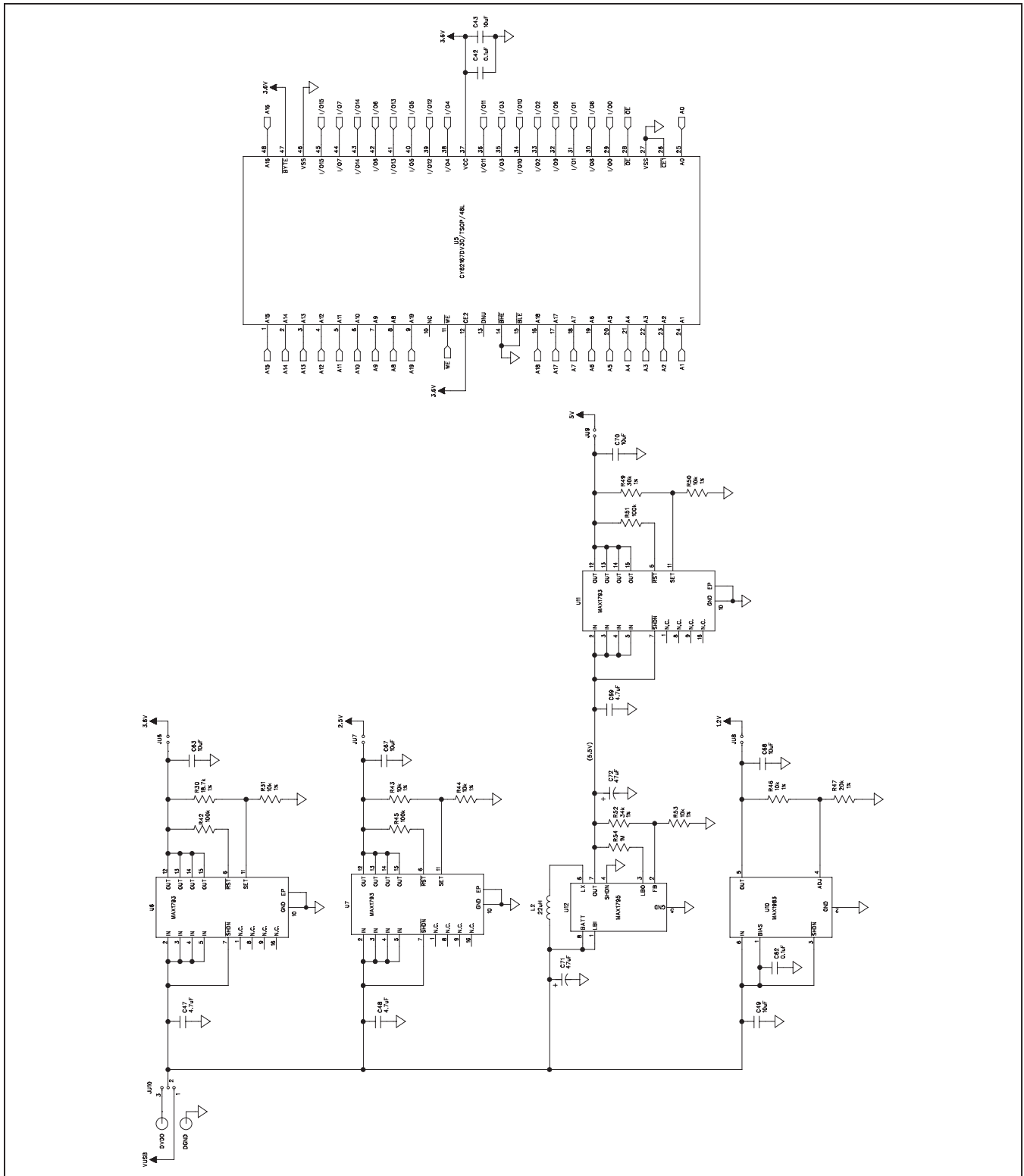

Figure 10c. MAX116XX SPI Master Board Schematic (Sheet 3 of 4)

MAX1231B/MAX11633/MAX11635 Evaluation Systems

Evaluate: MAX1030/MAX1031/MAX1230/ MAX1231/MAX11624/MAX11625/ MAX11632-MAX11635/MAX11642/MAX11643

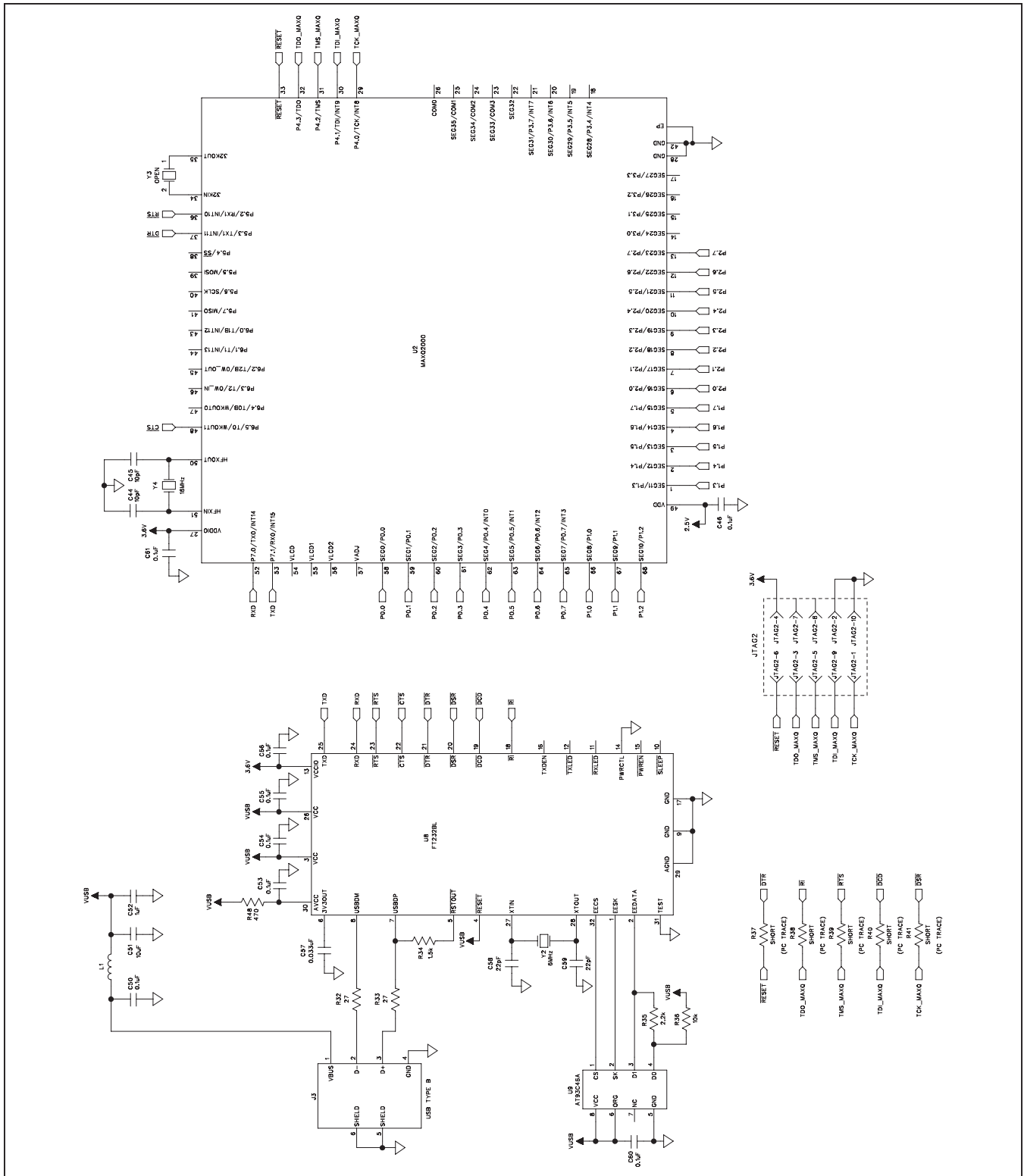

Figure 10d. MAX116XX SPI Master Board Schematic (Sheet 4 of 4)

MAX1231B/MAX11633/MAX11635 Evaluation Systems

Evaluate: MAX1030/MAX1031/MAX1230/ MAX1231/MAX11624/MAX11625/ MAX11632-MAX11635/MAX11642/MAX11643

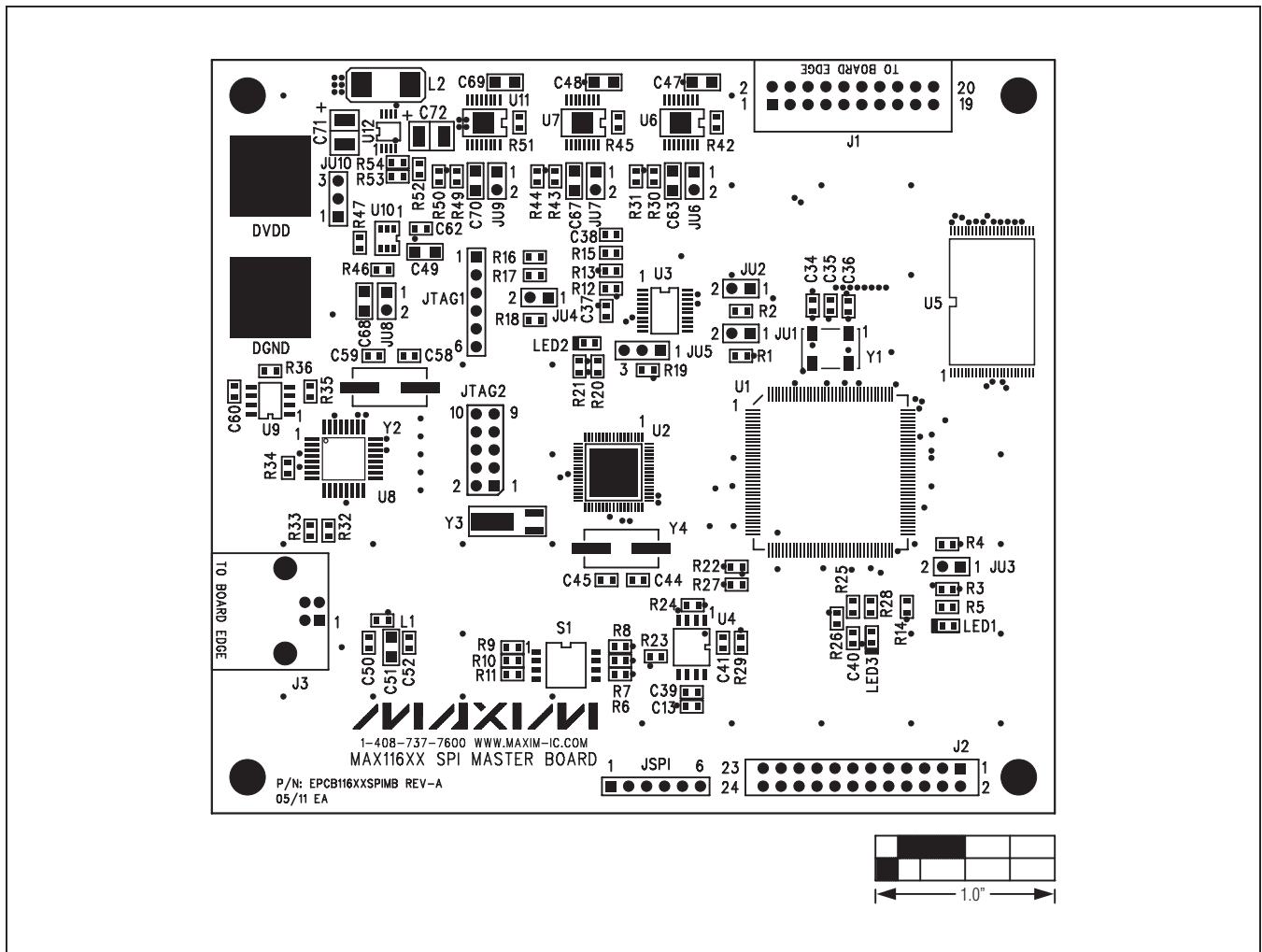

Figure 11. MAX116XX SPI Master Board Component Placement Guide—Top

MAX1231B/MAX11633/MAX11635 Evaluation Systems
Evaluate: MAX1030/MAX1031/MAX1230/
MAX1231/MAX11624/MAX11625/
MAX11632-MAX11635/MAX11642/MAX11643

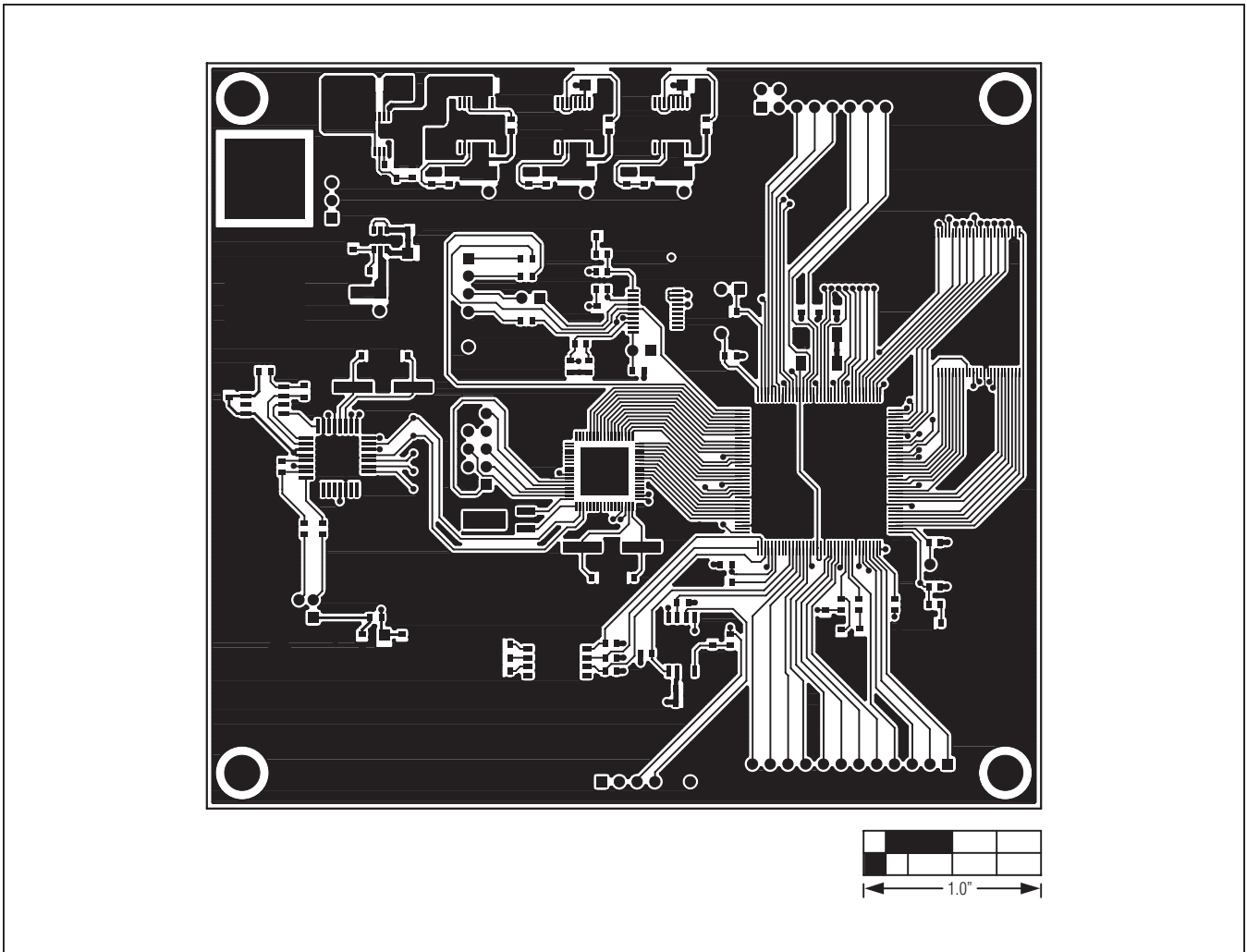

Figure 12. MAX116XX SPI Master Board PCB Layout—Component Side

MAX1231B/MAX11633/MAX11635 Evaluation Systems
Evaluate: MAX1030/MAX1031/MAX1230/
MAX1231/MAX11624/MAX11625/
MAX11632-MAX11635/MAX11642/MAX11643

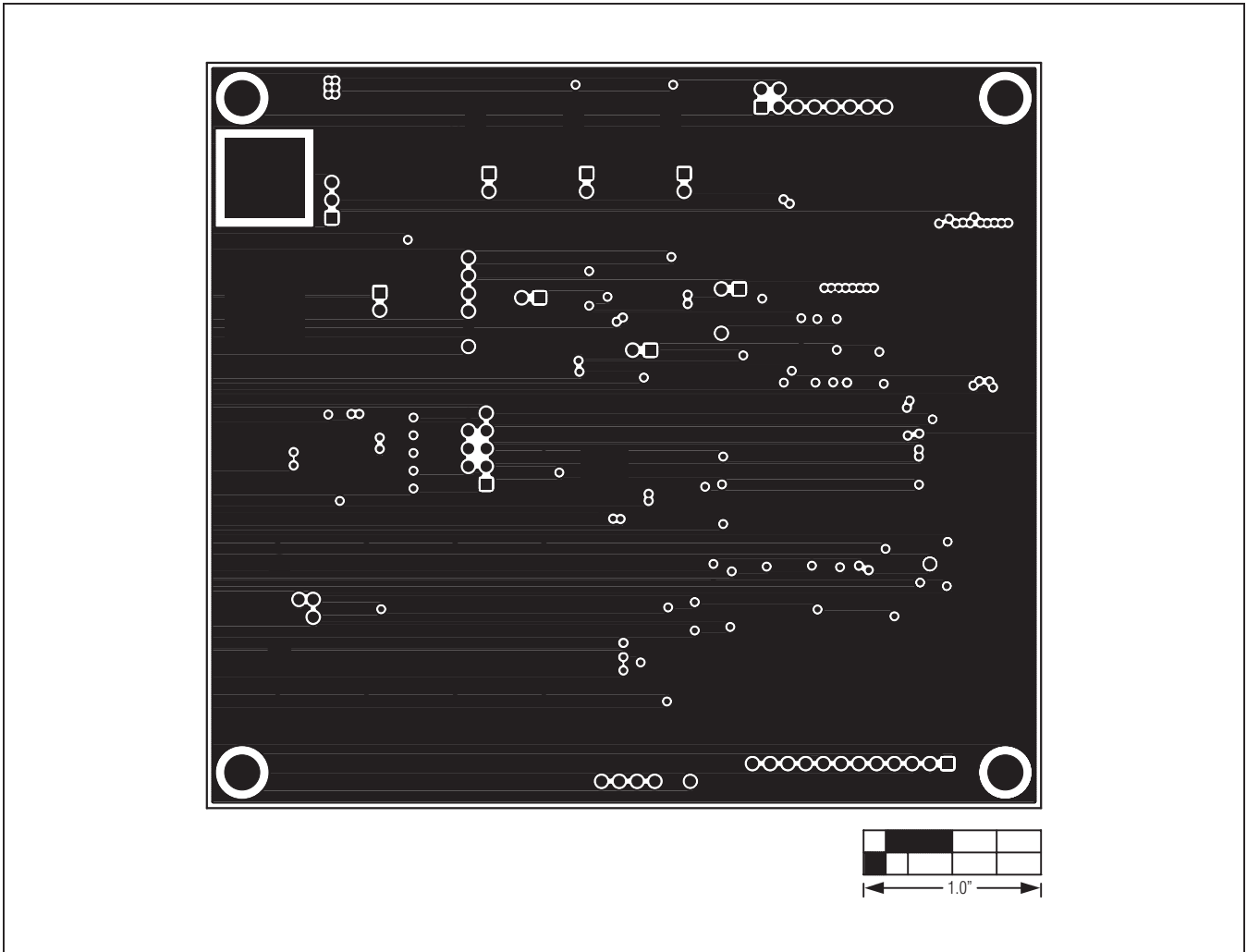

Figure 13. MAX116XX SPI Master Board PCB Layout—Layer 2

MAX1231B/MAX11633/MAX11635 Evaluation Systems
Evaluate: MAX1030/MAX1031/MAX1230/
MAX1231/MAX11624/MAX11625/
MAX11632-MAX11635/MAX11642/MAX11643

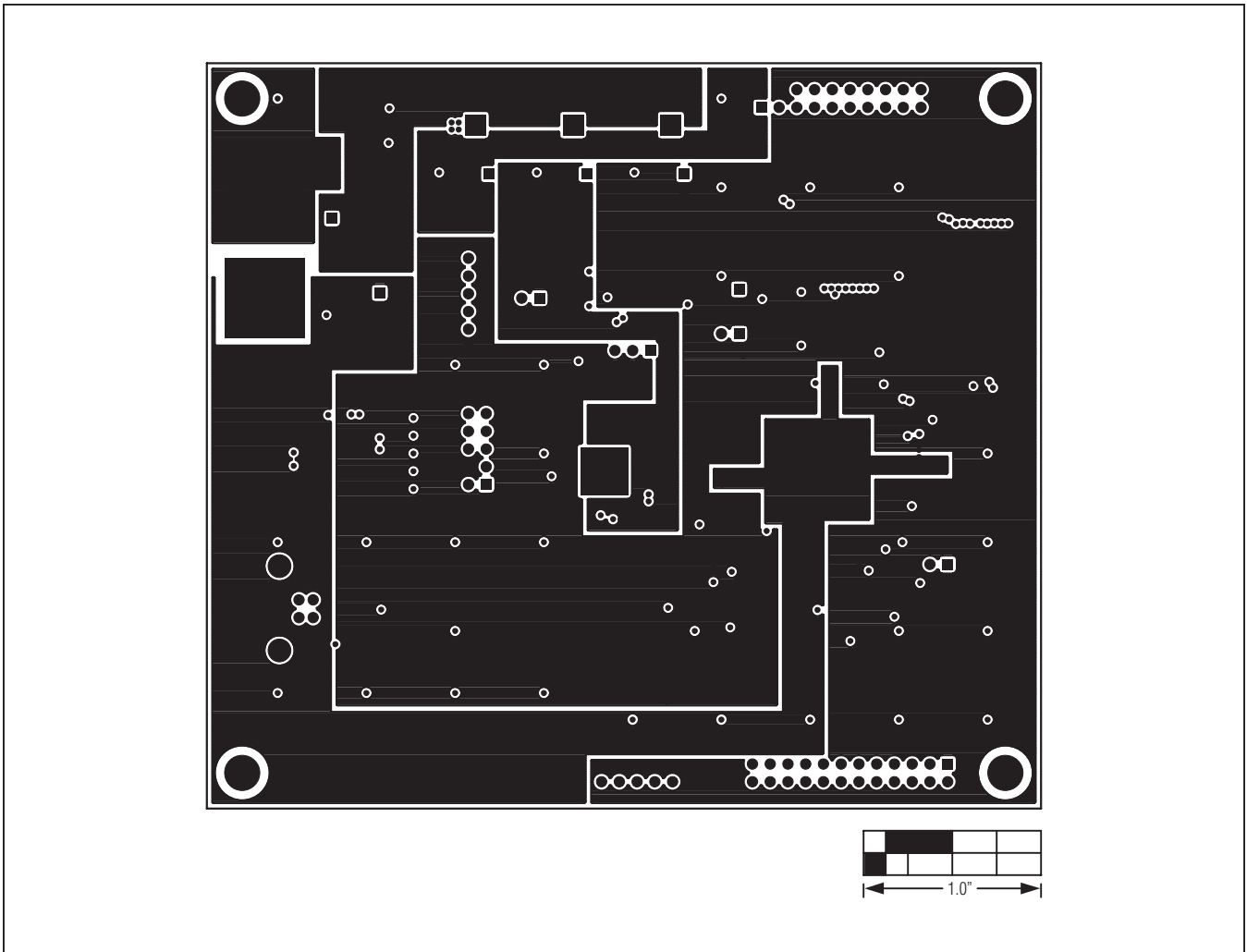

Figure 14. MAX116XX SPI Master Board PCB Layout—Layer 3

MAX1231B/MAX11633/MAX11635 Evaluation Systems
Evaluate: MAX1030/MAX1031/MAX1230/
MAX1231/MAX11624/MAX11625/
MAX11632-MAX11635/MAX11642/MAX11643

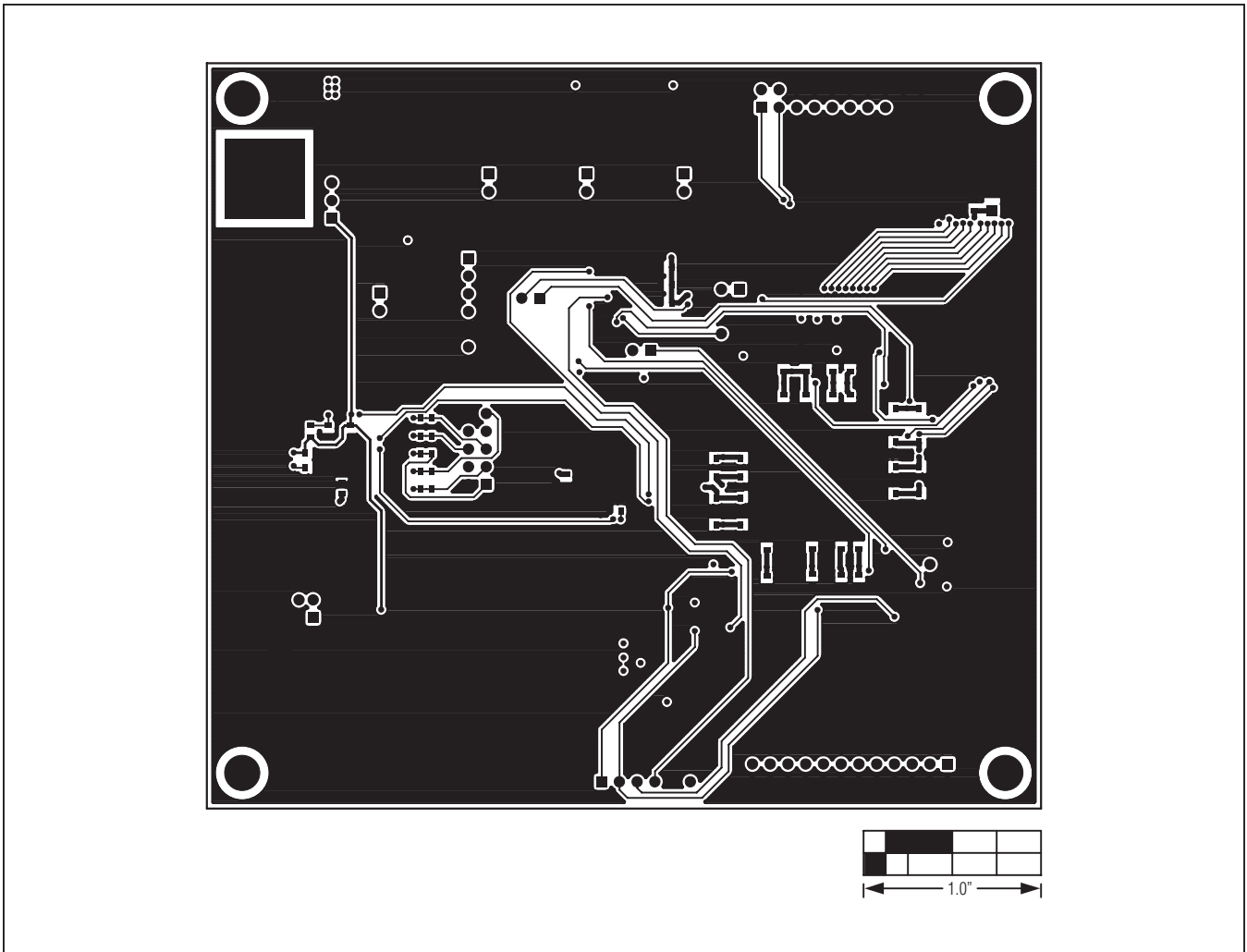

Figure 15. MAX116XX SPI Master Board PCB Layout—Bottom Side

MAX1231B/MAX11633/MAX11635 Evaluation Systems

Evaluate: MAX1030/MAX1031/MAX1230/ MAX1231/MAX11624/MAX11625/ MAX11632-MAX11635/MAX11642/MAX11643

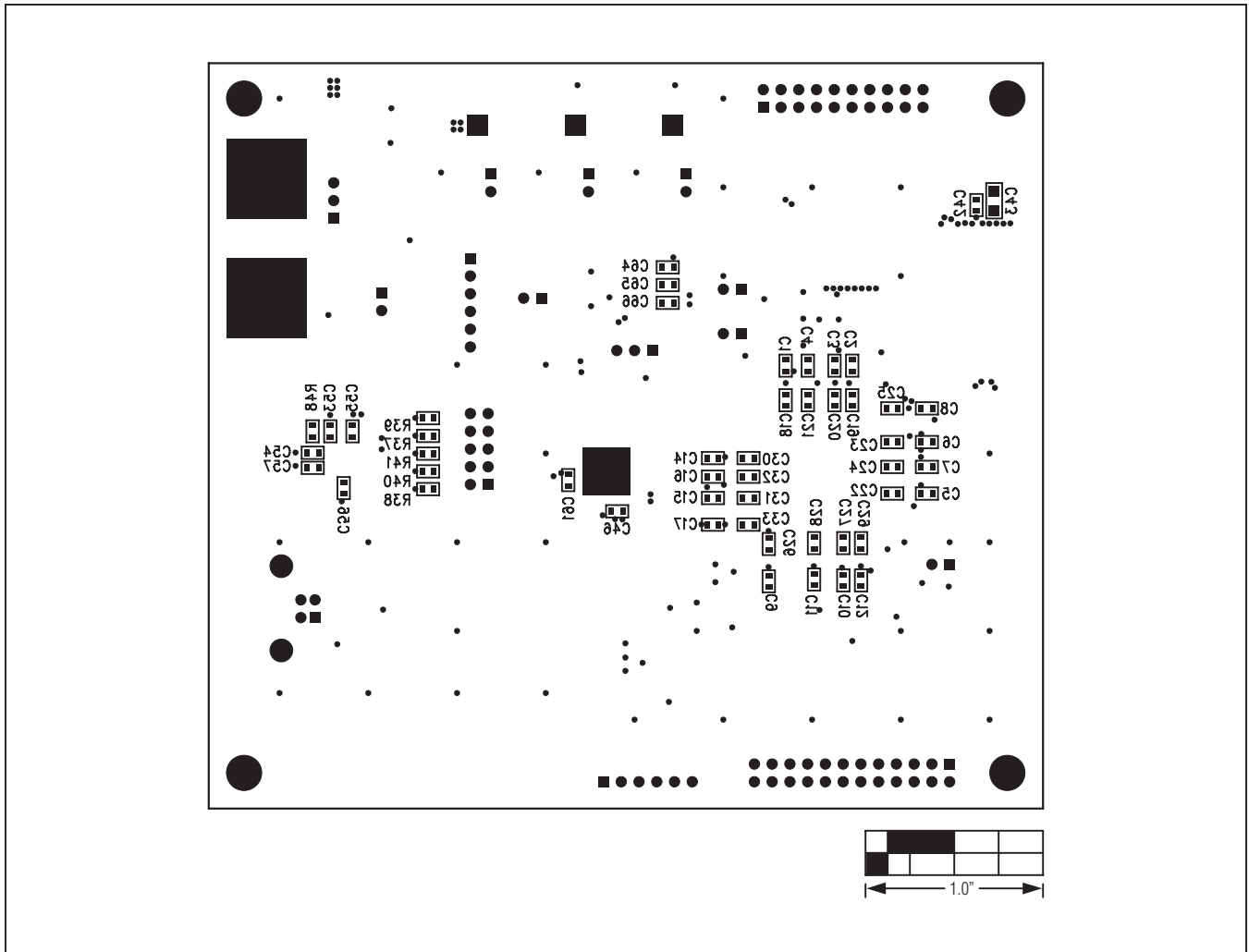

Figure 16. MAX116XX SPI Master Board Component Placement Guide—Bottom

MAX1231B/MAX11633/MAX11635 Evaluation Systems

Evaluate: MAX1030/MAX1031/MAX1230/ MAX1231/MAX11624/MAX11625/ MAX11632-MAX11635/MAX11642/MAX11643

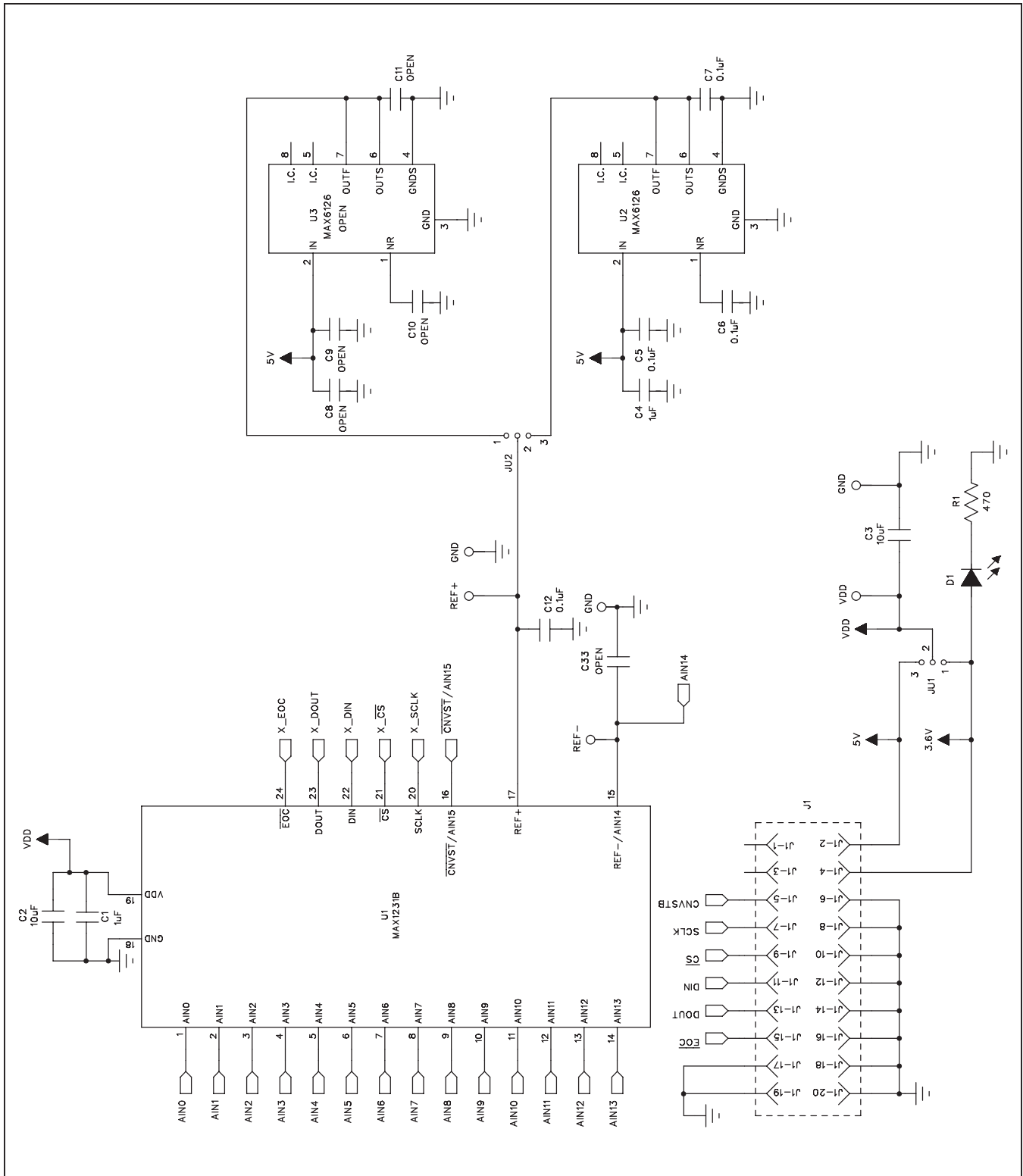

Figure 17a MAX1231B EV Kit Daughter Board Schematic (Sheet 1 of 3)

MAX1231B/MAX11633/MAX11635 Evaluation Systems

Evaluate: MAX1030/MAX1031/MAX1230/ MAX1231/MAX11624/MAX11625/ MAX11632-MAX11635/MAX11642/MAX11643

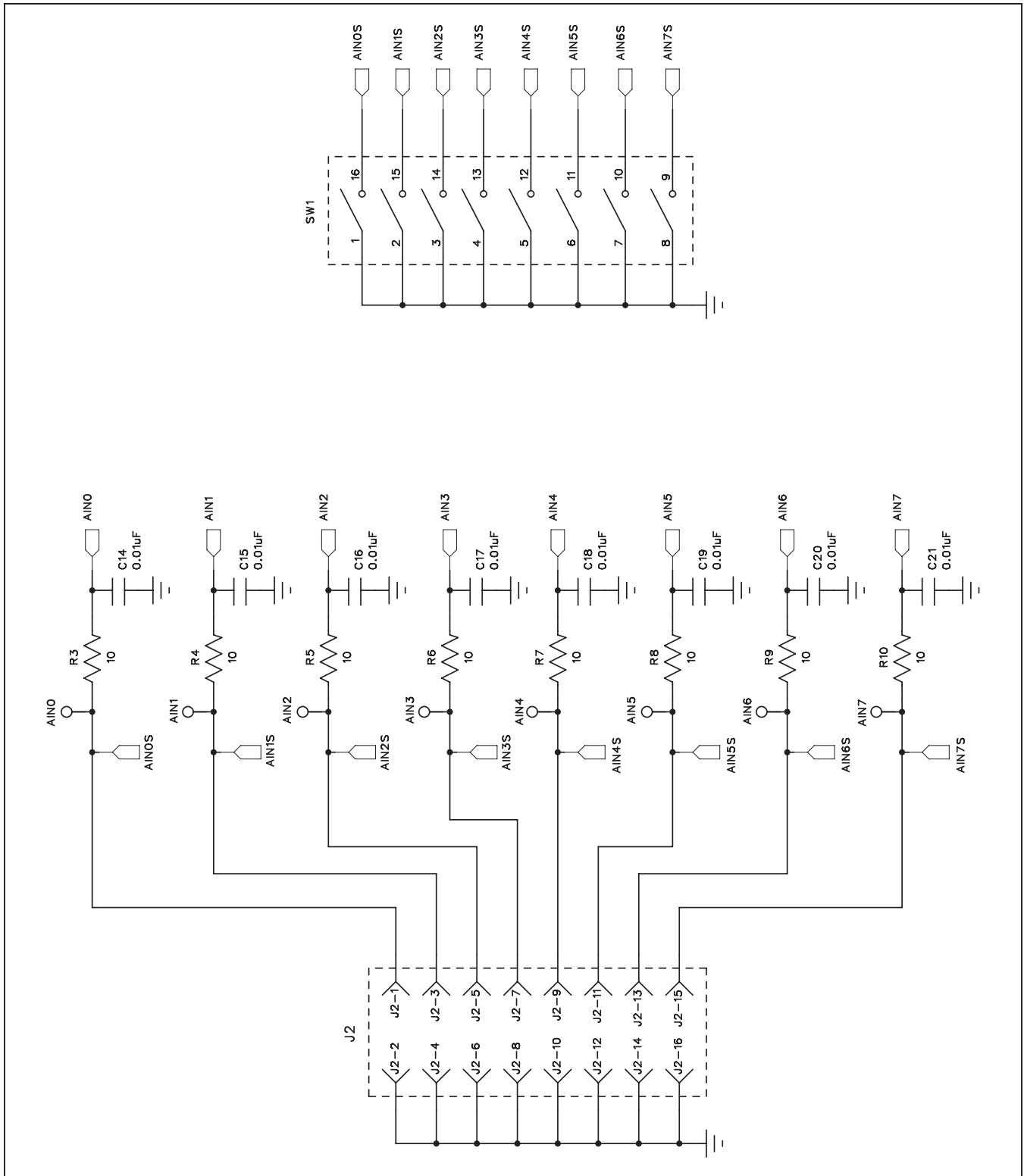

Figure 17b. MAX1231B EV Kit Daughter Board Schematic (Sheet 2 of 3)

MAX1231B/MAX11633/MAX11635 Evaluation Systems

Evaluate: MAX1030/MAX1031/MAX1230/ MAX1231/MAX11624/MAX11625/ MAX11632-MAX11635/MAX11642/MAX11643

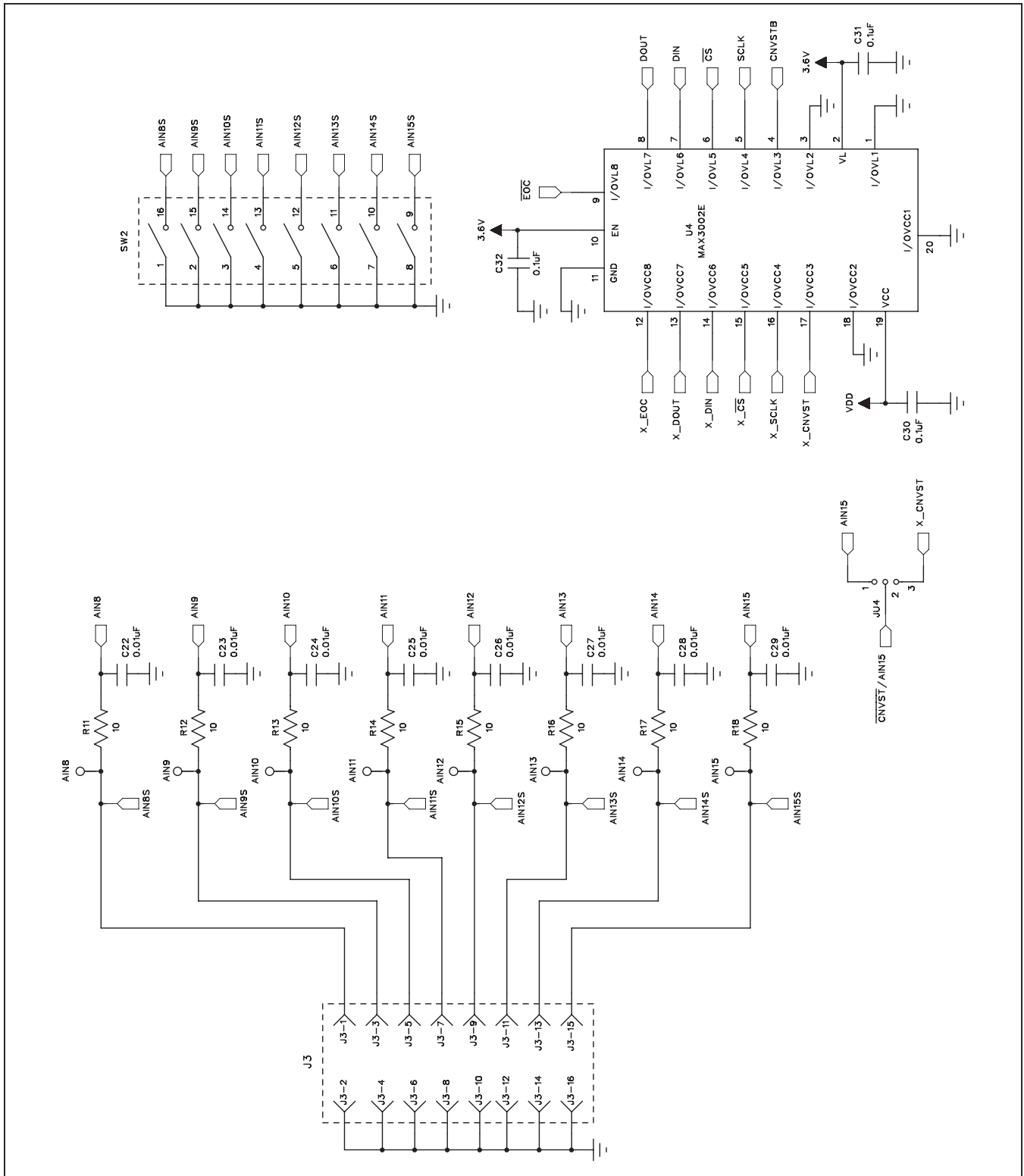

Figure 17c. MAX1231B EV Kit Daughter Board Schematic (Sheet 3 of 3)

MAX1231B/MAX11633/MAX11635 Evaluation Systems

Evaluate: MAX1030/MAX1031/MAX1230/ MAX1231/MAX11624/MAX11625/ MAX11632-MAX11635/MAX11642/MAX11643

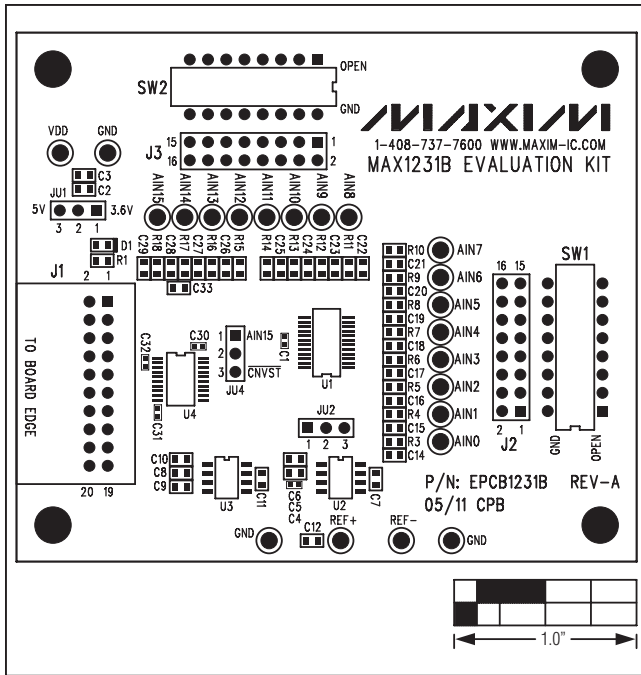

Figure 18. MAX1231B EV Kit Daughter Board Component Placement Guide

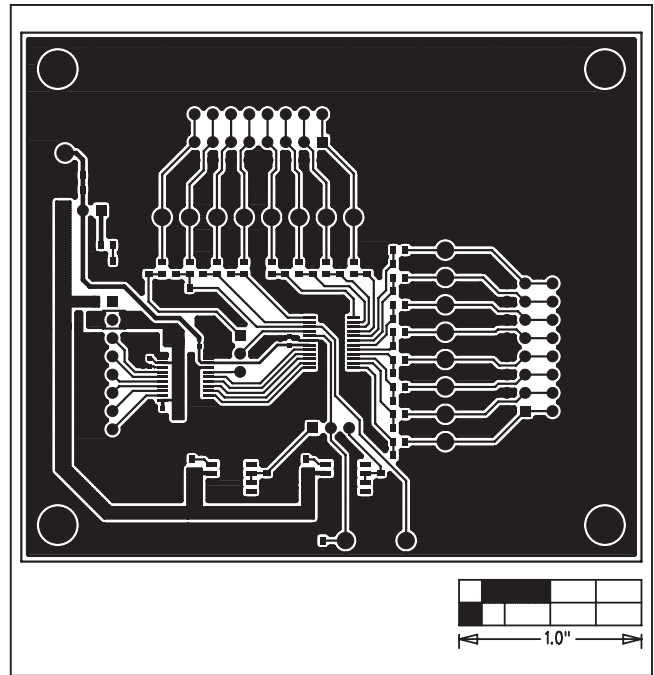

Figure 19. MAX1231B EV Kit Daughter Board PCB Layout—Top

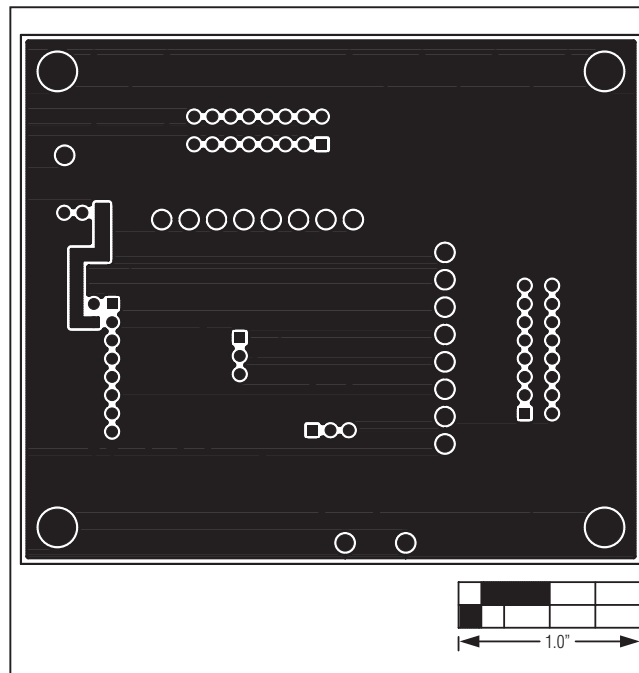

Figure 20. MAX1231B EV Kit Daughter Board PCB Layout—Bottom

MAX1231B/MAX11633/MAX11635 Evaluation Systems

Evaluate: MAX1030/MAX1031/MAX1230/ MAX1231/MAX11624/MAX11625/ MAX11632-MAX11635/MAX11642/MAX11643

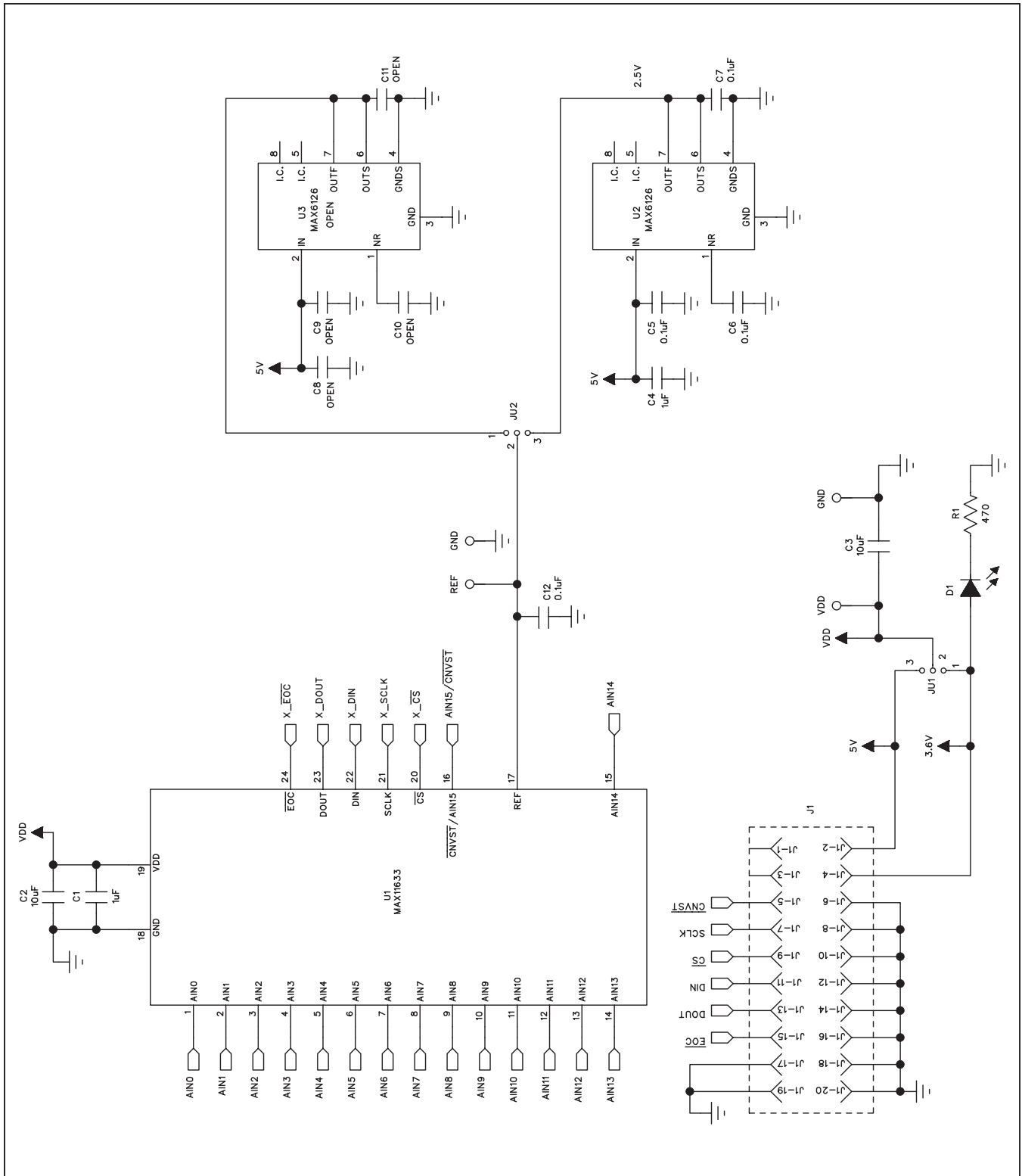

Figure 21a. MAX11633 Daughter Board Schematic (Sheet 1 of 3)

MAX1231B/MAX11633/MAX11635 Evaluation Systems

Evaluate: MAX1030/MAX1031/MAX1230/ MAX1231/MAX11624/MAX11625/ MAX11632-MAX11635/MAX11642/MAX11643

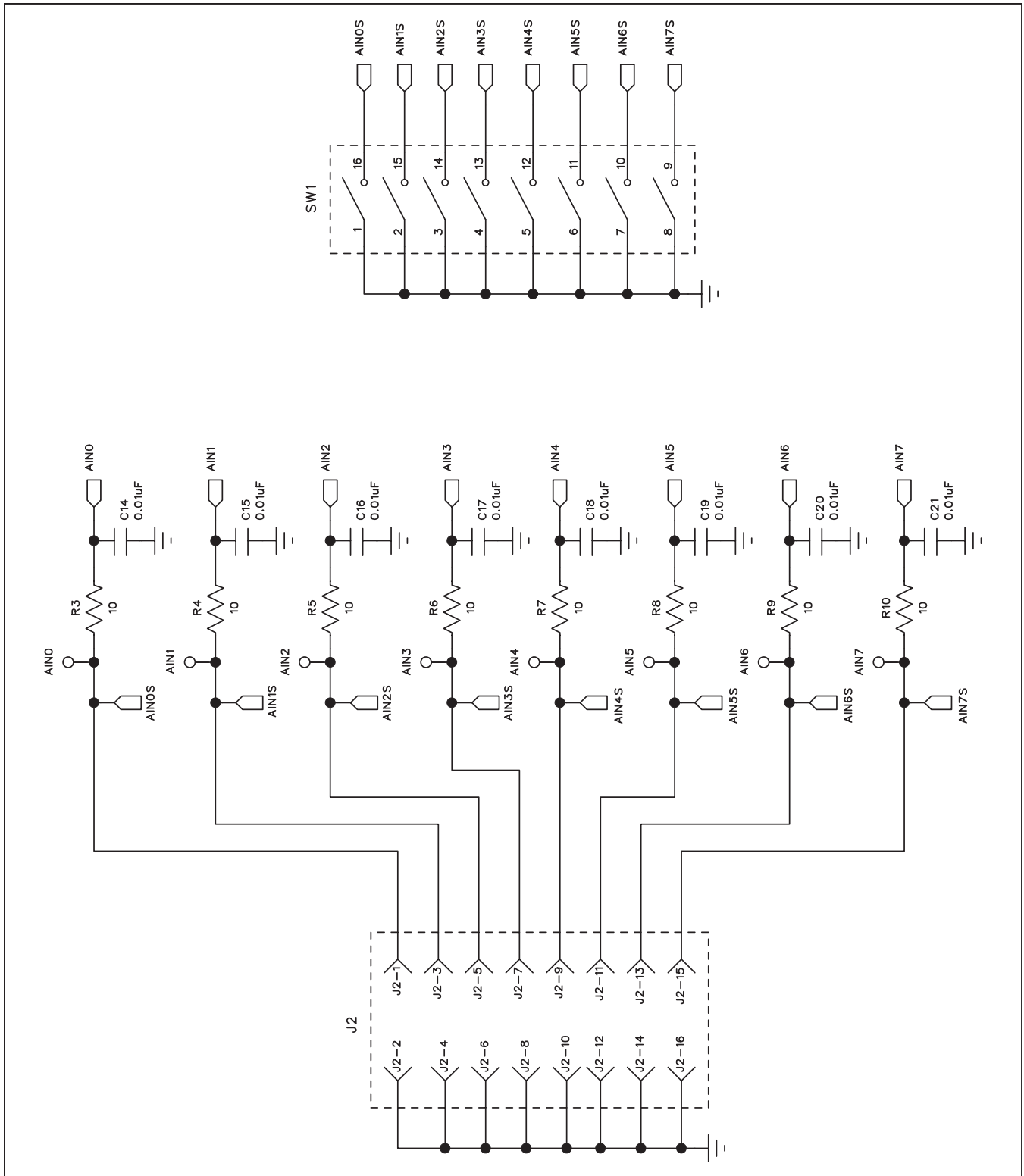

Figure 21b. MAX11633 Daughter Board Schematic (Sheet 2 of 3)

MAX1231B/MAX11633/MAX11635 Evaluation Systems

Evaluate: MAX1030/MAX1031/MAX1230/ MAX1231/MAX11624/MAX11625/ MAX11632-MAX11635/MAX11642/MAX11643

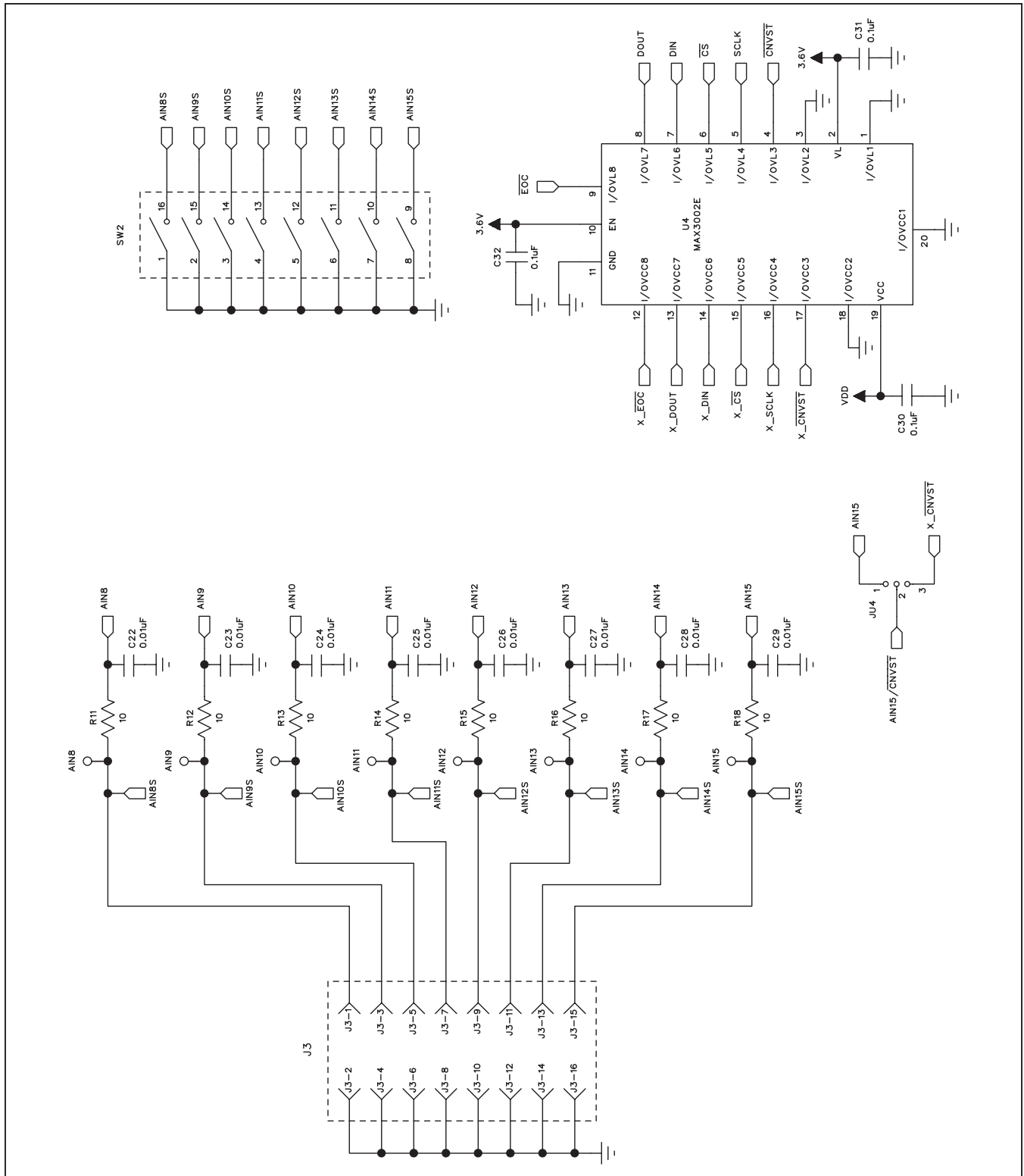

Figure 21c. MAX11633 Daughter Board Schematic (Sheet 3 of 3)

MAX1231B/MAX11633/MAX11635 Evaluation Systems

Evaluate: MAX1030/MAX1031/MAX1230/ MAX1231/MAX11624/MAX11625/ MAX11632-MAX11635/MAX11642/MAX11643

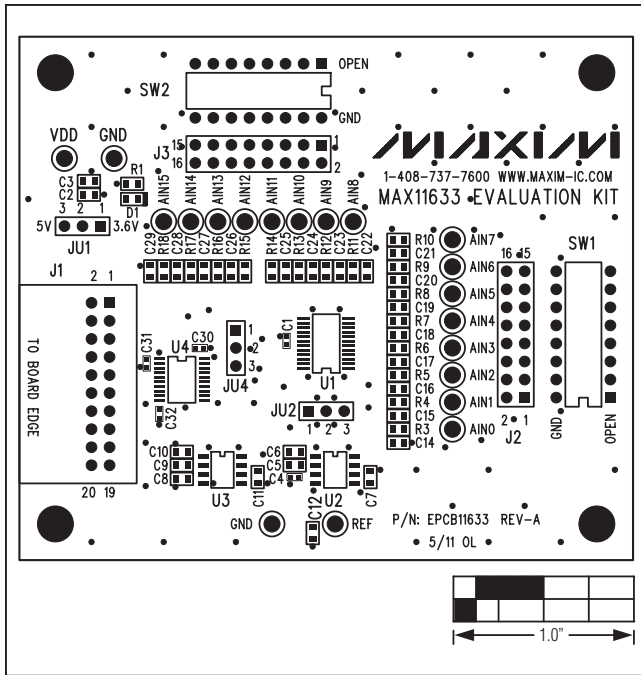

Figure 22. MAX11633 Daughter Board Component Placement Guide

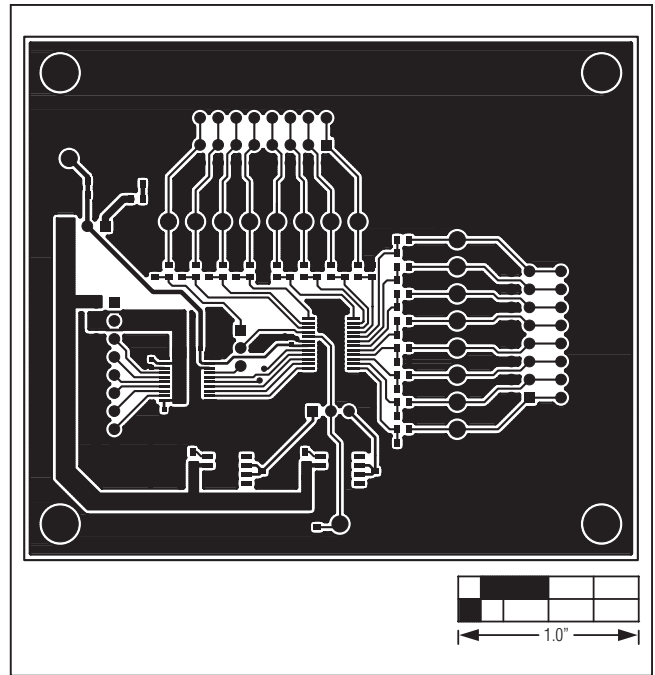

Figure 23. MAX11633 Daughter Board PCB Layout—Top

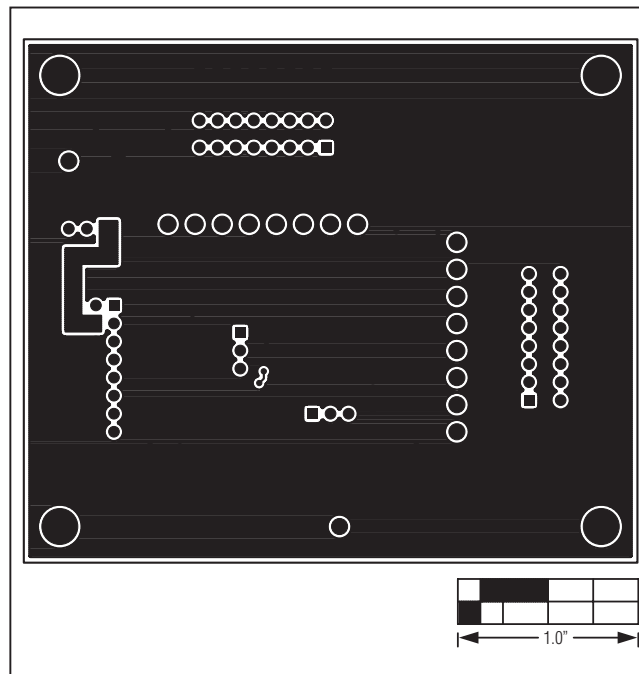

Figure 24. MAX11633 Daughter Board PCB Layout—Bottom

MAX1231B/MAX11633/MAX11635 Evaluation Systems

Evaluate: MAX1030/MAX1031/MAX1230/ MAX1231/MAX11624/MAX11625/ MAX11632-MAX11635/MAX11642/MAX11643

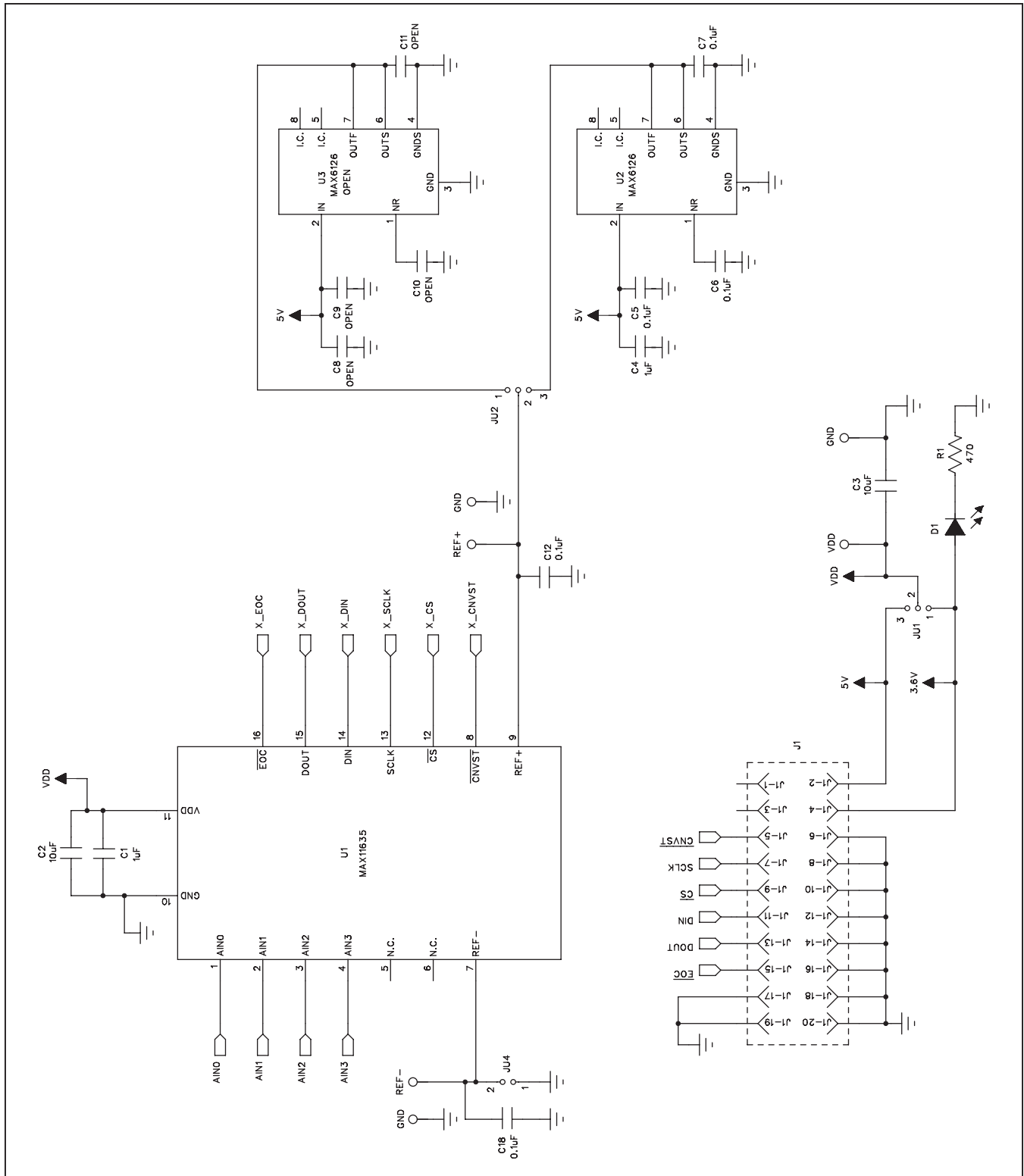

Figure 25a. MAX11635 Daughter Board Schematic (Sheet 1 of 2)

MAX1231B/MAX11633/MAX11635 Evaluation Systems

Evaluate: MAX1030/MAX1031/MAX1230/ MAX1231/MAX11624/MAX11625/ MAX11632-MAX11635/MAX11642/MAX11643

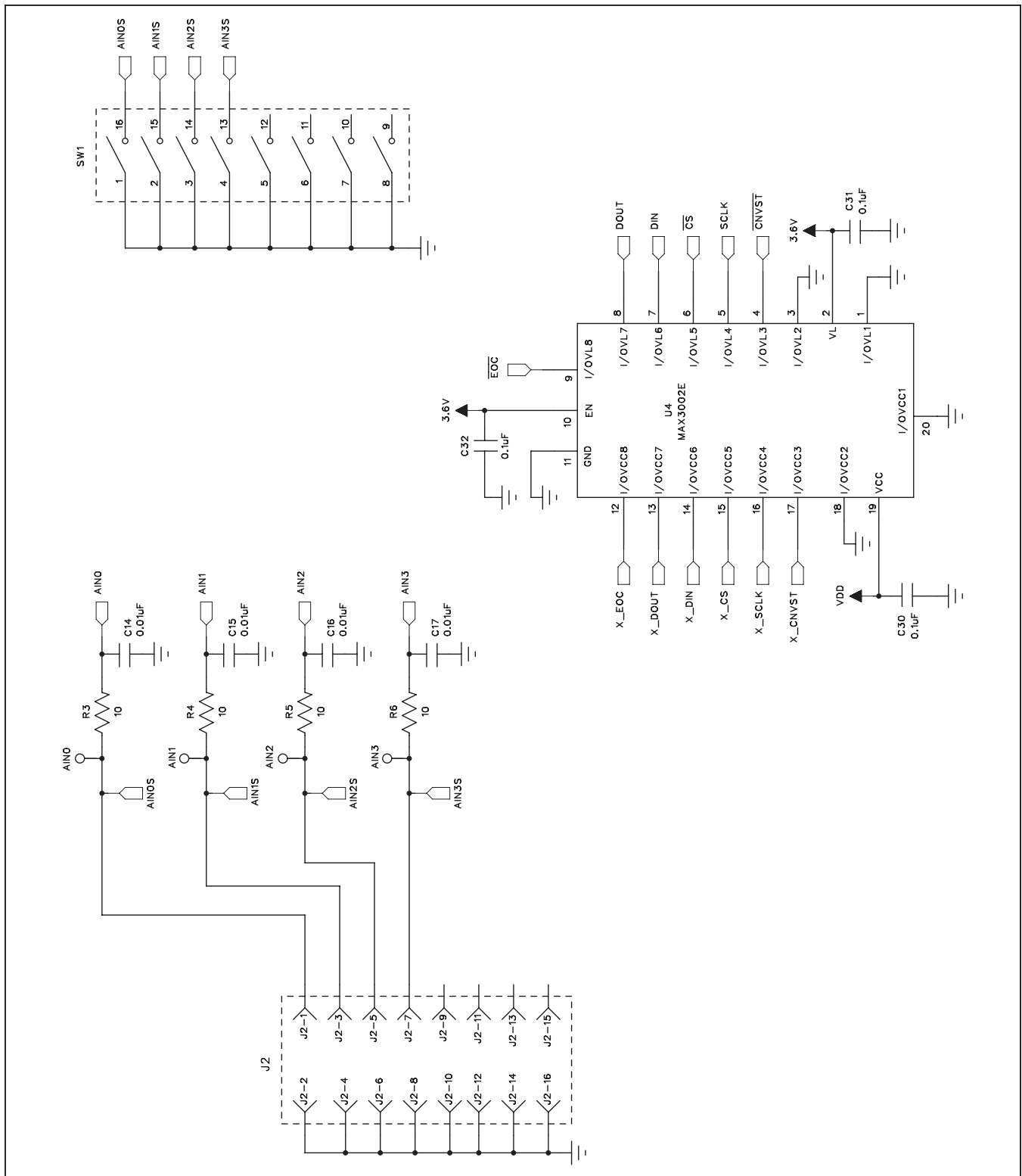

Figure 25b. MAX11635 Daughter Board Schematic (Sheet 2 of 2)

MAX1231B/MAX11633/MAX11635 Evaluation Systems

Evaluate: MAX1030/MAX1031/MAX1230/ MAX1231/MAX11624/MAX11625/ MAX11632-MAX11635/MAX11642/MAX11643

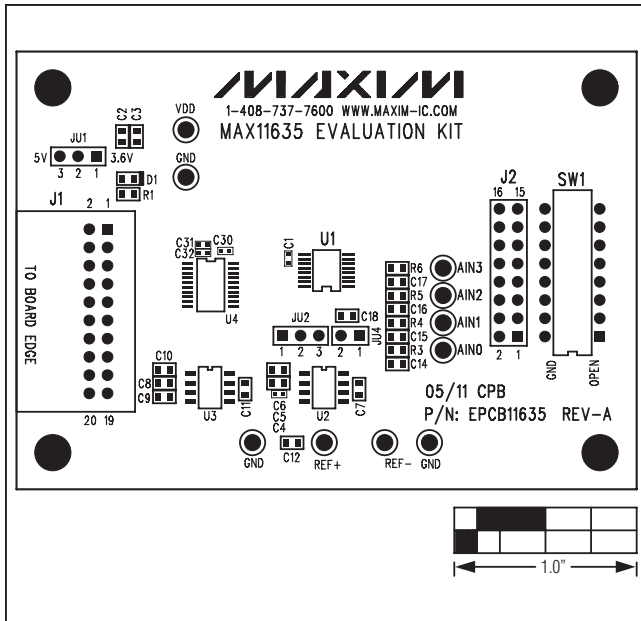

Figure 26. MAX11635 Daughter Board Component Placement Guide

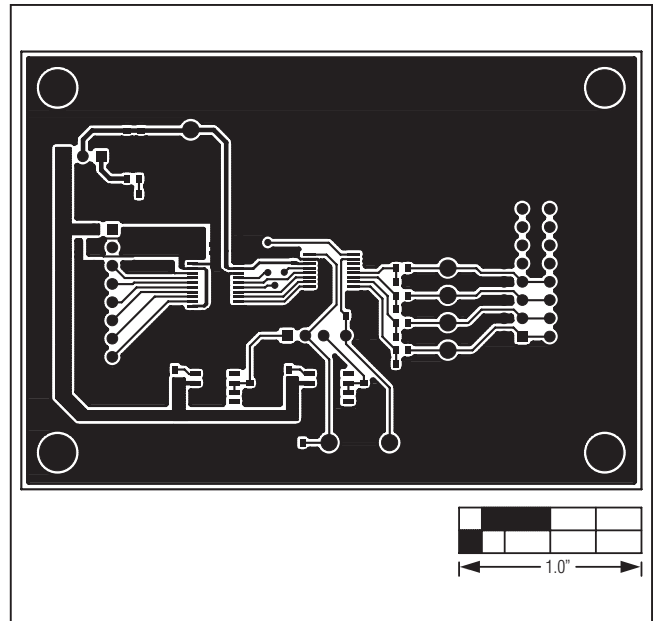

Figure 27. MAX11635 Daughter Board PCB Layout—Top

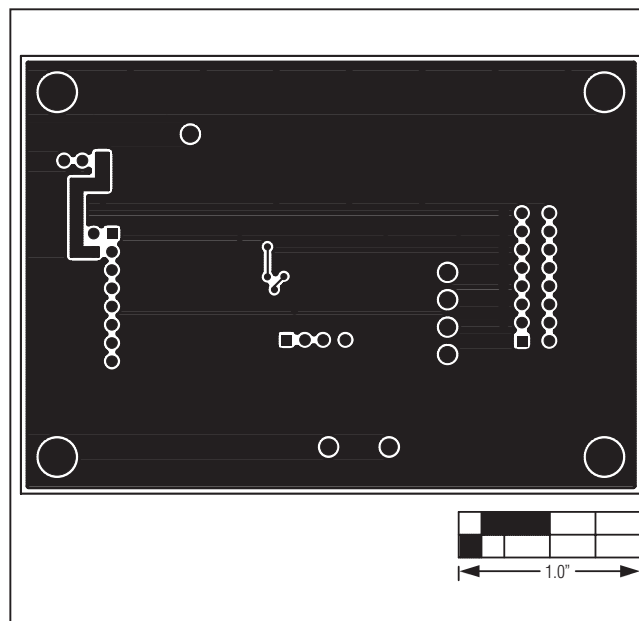

Figure 28. MAX11635 Daughter Board PCB Layout—Bottom

MAX1231B/MAX11633/MAX11635 Evaluation Systems

Evaluate: MAX1030/MAX1031/MAX1230/ MAX1231/MAX11624/MAX11625/ MAX11632–MAX11635/MAX11642/MAX11643

Ordering Information/Selector Guide

PART	COMPATIBLE ADC	DESCRIPTION
MAX1231BEVSYS#	MAX1030BEEG+	10-bit, 5V supply, 16-channel, 4.096V internal reference
	MAX1031BEEG+	10-bit, 3V supply, 16-channel, 2.5V internal reference
	MAX1230BEEG+	12-bit, 5V supply, 16-channel, 4.096V internal reference
	MAX1231BEEG+*	12-bit, 3V supply, 16-channel, 2.5V internal reference
MAX11633EVSYS#	MAX11624EEG+	10-bit, 5V supply, 16-channel, 4.096V internal reference
	MAX11625EEG+	10-bit, 3V supply, 16-channel, 2.5V internal reference
	MAX11632EEG+	12-bit, 5V supply, 16-channel, 4.096V internal reference
	MAX11633EEG+*	12-bit, 3V supply, 16-channel, 2.5V internal reference
	MAX11642EEG+	8-bit, 5V supply, 16-channel, 4.096V internal reference
	MAX11643EEG+	8-bit, 3V supply, 16-channel, 2.5V internal reference
MAX11635EVSYS#	MAX11634EEE+	12-bit, 5V supply, 4-channel, 4.096V internal reference
	MAX11635EEE+*	12-bit, 3V supply, 4-channel, 2.5V internal reference

*Default ADC installed on the daughter board.

#Denotes RoHS compliant.

#Denotes RoHS compliant.

+Denotes lead(Pb)-free and RoHS compliant.

MAX1231B/MAX11633/MAX11635 Evaluation Systems
Evaluate: MAX1030/MAX1031/MAX1230/
MAX1231/MAX11624/MAX11625/
MAX11632-MAX11635/MAX11642/MAX11643

Revision History

REVISION NUMBER	REVISION DATE	DESCRIPTION	PAGES CHANGED
0	8/11	Initial release	—
1	4/12	Changed ordering part numbers from lead(Pb)-free to RoHS compliant	39

Maxim cannot assume responsibility for use of any circuitry other than circuitry entirely embodied in a Maxim product. No circuit patent licenses are implied. Maxim reserves the right to change the circuitry and specifications without notice at any time.

Maxim Integrated Products, 120 San Gabriel Drive, Sunnyvale, CA 94086 408-737-7600 _____ 40



Стандарт Электрон Связь

Мы молодая и активно развивающаяся компания в области поставок электронных компонентов. Мы поставляем электронные компоненты отечественного и импортного производства напрямую от производителей и с крупнейших складов мира.

Благодаря сотрудничеству с мировыми поставщиками мы осуществляем комплексные и плановые поставки широчайшего спектра электронных компонентов.

Собственная эффективная логистика и склад в обеспечивает надежную поставку продукции в точно указанные сроки по всей России.

Мы осуществляем техническую поддержку нашим клиентам и предпродажную проверку качества продукции. На все поставляемые продукты мы предоставляем гарантию .

Осуществляем поставки продукции под контролем ВП МО РФ на предприятия военно-промышленного комплекса России , а также работаем в рамках 275 ФЗ с открытием отдельных счетов в уполномоченном банке. Система менеджмента качества компании соответствует требованиям ГОСТ ISO 9001.

Минимальные сроки поставки, гибкие цены, неограниченный ассортимент и индивидуальный подход к клиентам являются основой для выстраивания долгосрочного и эффективного сотрудничества с предприятиями радиоэлектронной промышленности, предприятиями ВПК и научно-исследовательскими институтами России.

С нами вы становитесь еще успешнее!

Наши контакты:

Телефон: +7 812 627 14 35

Электронная почта: sales@st-electron.ru

Адрес: 198099, Санкт-Петербург,
Промышленная ул, дом № 19, литера Н,
помещение 100-Н Офис 331