

### Product Overview

The QPA4501 is an integrated 2-stage Power Amplifier Module designed for massive MIMO applications up to 3 W RMS at the device output covering frequency range from 4.4 to 5.0 GHz.

The module is 50 Ω input and output and requires minimal external components. The module is also compact and offers a much smaller footprint than traditional discrete component solutions.

The QPA4501 incorporates a Doherty final stage delivering high power added efficiency for the entire module up to 3 W average power.

RoHS compliant.



36 Pad 6 x 10 mm Plastic QFN Package

### Key Features

- Operating Frequency Range: 4.4 – 5.0 GHz
- Operating Drain Voltage: +28 V
- 50 Ω Input / Output
- Integrated Doherty Final Stage
- Gain at 1.25 W Avg.: 29.9 dB
- Power Added Efficiency at 1.25 W Avg.: 25.7%
- Power Added Efficiency at 3 W Avg.: 38%
- 6 x 10 mm Plastic Surface Mount Package

Note: T = +25°C, single-carrier, 20 MHz LTE signal with 7.8 dB PAR at 0.01% CCDF.

### Functional Block Diagram

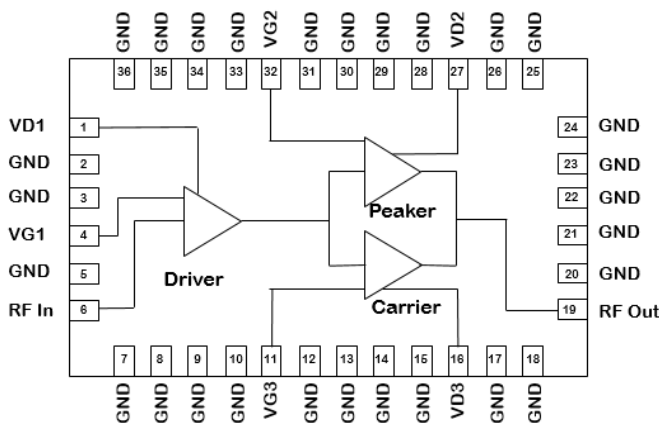

### Applications

- 5G Massive MIMO
- W-CDMA / LTE
- Macrocell Base Station Driver
- Microcell Base Station
- Small Cell Final Stage
- Active Antenna
- General Purpose Applications

### Ordering Information

Part No.	Description
QPA4501SB	Sample Bag – 5 Pieces
QPA4501SR	Short Reel – 100 Pieces
QPA4501TR13	13" Reel – 2500 Pieces
QPA4501EVB01	Tested 4.4 – 5.0 GHz EVB

## Absolute Maximum Ratings

Parameter	Value	Units
Breakdown Voltage ( $V_{BDG}$ )	120	V
Gate Voltage ( $V_{G1,2,3}$ )	-7 to +2	V
Drain Voltage ( $V_{D1,2,3}$ )	+40	V
RF Input Power <sup>(1)</sup>	+12	dBm
VSWR Mismatch, P3dB Pulse (10% Duty Cycle, 100 $\mu$ s Pulse Width), T = +25°C	10:1	
Power Dissipation	63	W

Notes:

1. Tested at 4.7 GHz, T = +25°C, single-carrier, 20 MHz LTE signal with 7.8 dB PAR at 0.01% CCDF.
2. Exceeding any one or a combination of the Absolute Maximum Rating conditions may cause permanent damage to the device. Extended application of Absolute Maximum Rating conditions to the device may reduce device reliability.

## Recommended Operating Conditions

Parameter	Min	Typ	Max	Units
Gate Voltage ( $V_{G1}$ )		-2.6		V
Gate Voltage ( $V_{G2}$ )		-4.2		V
Gate Voltage ( $V_{G3}$ )		-2.6		V
Drain Voltage ( $V_{D1,2,3}$ )		+28		V
Quiescent Current ( $I_{DQ1}$ )		50		mA
Quiescent Current ( $I_{DQ3}$ )		75		mA
Power Dissipation		3.8		W

Note: Electrical specifications are measured at specified test conditions. Specifications are not guaranteed over all recommended operating conditions.

## Electrical Specifications

Parameter	Conditions	Min	Typ	Max	Units
Frequency Range		4.4		5.0	GHz
Driver Quiescent Current ( $I_{DQ1}$ )			50		mA
Carrier Quiescent Current ( $I_{DQ3}$ )			75		mA
Gain	$P_{AVG} = 31$ dBm	26.0	29.9		dB
Saturated Power ( $P_{SAT}$ )	Pulse (10% Duty Cycle, 500 $\mu$ s Width), $P_{IN} = 19$ dBm	41.9	43.5		dBm
Power Added Efficiency (PAE)	$P_{AVG} = 31$ dBm	19.8	25.7		%
Raw ACLR	$P_{AVG} = 31$ dBm		-35.1		dBc

Test conditions unless otherwise noted:  $V_{D1,2,3} = +28$  V,  $I_{DQ1} = 50$  mA,  $I_{DQ3} = 75$  mA,  $V_{G2} = -4.2$  V, T = +25°C, using a single-carrier, 20 MHz LTE signal with 7.8 dB PAR at 0.01% CCDF on the reference design fixture.

## Thermal Information

Parameter	Conditions	Values	Units
Peak IR Surface Thermal Resistance at Average Power ( $\theta_{JC}$ )	$T_{CASE} = +85^\circ\text{C}$ , $T_{CH} = 91^\circ\text{C}$ CW: $P_{DISS} = 4$ W, $P_{OUT} = 1.25$ W	1.5	°C/W

Notes:

1. Based on expected carrier amplifier efficiency of Doherty.
2.  $P_{OUT}$  assumes 10% peaking amplifier contribution of total average Doherty rated power.
3. Thermal resistance is measured to package backside.
4. Refer to the following document: [GaN Device Channel Temperature, Thermal Resistance, and Reliability Estimates](#)

## QPA4501 4.4 – 5.0 GHz Reference Design

EVB Layout

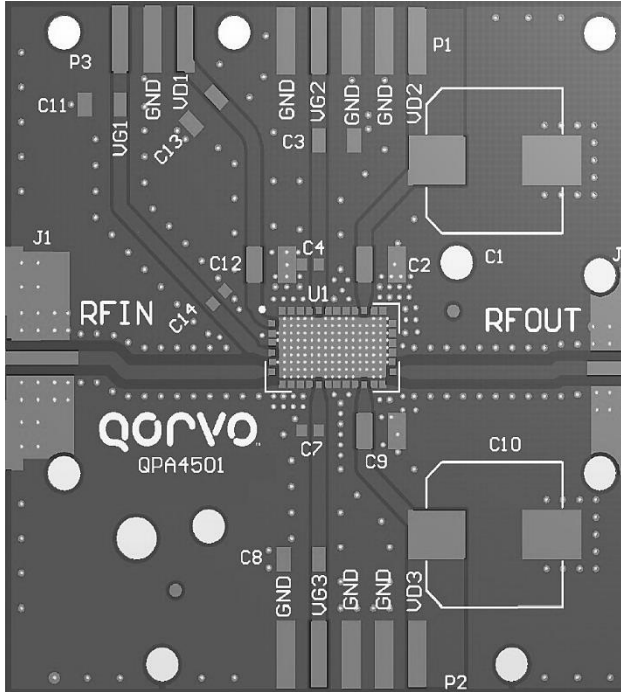

EVB Schematic

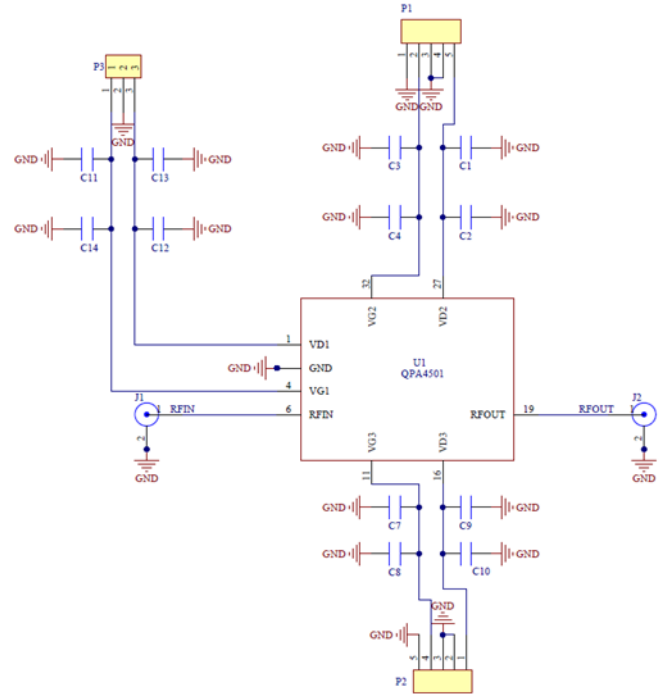

PCB Stackup and Material

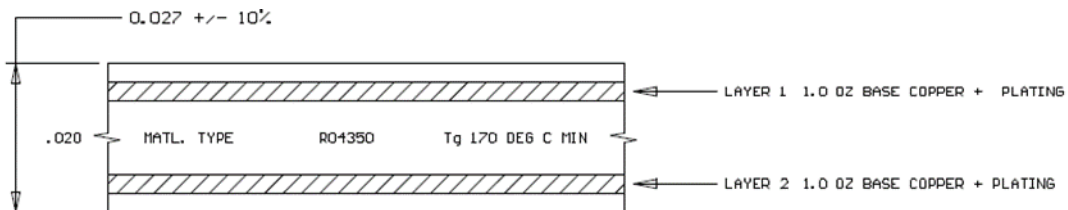

**Notes:**

1. All dimensions are in inches.
2. PCB is soldered on a 2 in. x 2 in. copper base plate with 0.25 in. thickness.

## Bill of Materials – QPA4501 4.4 – 5.0 GHz Evaluation Board

Reference Des.	Value	Description	Manufacturer	Part Number
C1, C10	220 $\mu$ F	Capacitor, 220 $\mu$ F, electrolytic, 50 V	Panasonic	EEEFK1H221P
C4, C7, C14	22,000 pF	Capacitor, 22,000 pF, 10%, 50 V, X7R, 0603	Murata	GRM188R71H223KA01D
C3, C8, C11, C13	4.7 $\mu$ F	Capacitor, 4.7 $\mu$ F, 10%, 50 V, X7R, 1206	Murata	GRM31CR71H475KA12L
C2, C9, C12	10 $\mu$ F	Capacitor, 10 $\mu$ F, 10%, 50 V, X7R, 1210	Murata	GRM32ER71H106KA
J1, J2		Connector, SMA, 4-Hole Panel Mount Jack	Gigalane	PAF-S00-000
P1, P2		Connector, HDR, ST, PLRZD, 5-Pin, 0.100"	ITW Pancon	MPSS100-5-C
P3		Connector, HDR, ST, 3-PIN, T/H	Molex	22-28-4033
U1		3 W 4.4 – 5.0 GHz GaN PA Module	Qorvo	QPA4501

**Performance Plots**

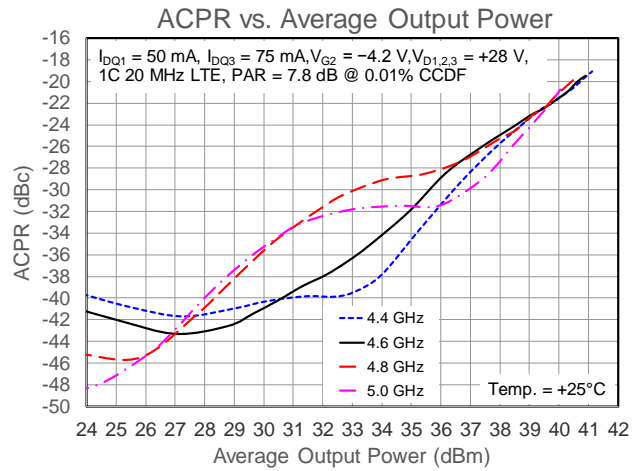
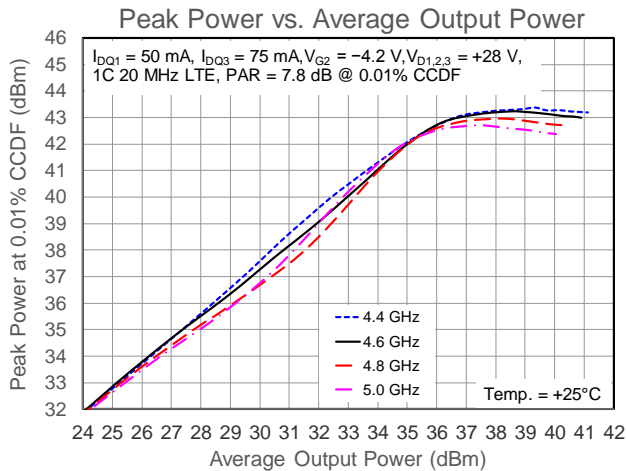
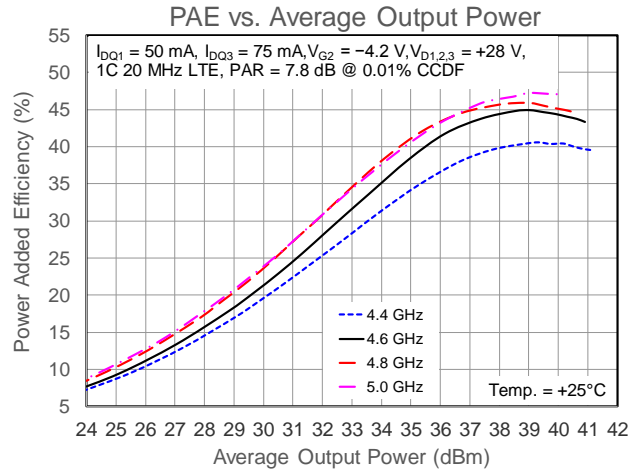
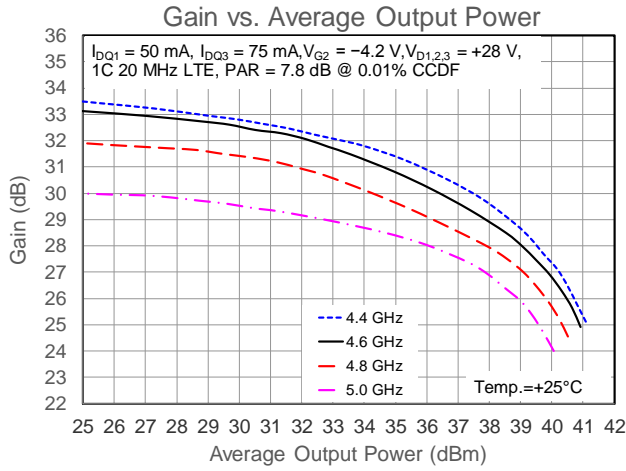

Test conditions unless otherwise noted:  $V_{D1,2,3} = +28 \text{ V}$ ,  $I_{DQ1} = 50 \text{ mA}$ ,  $I_{DQ3} = 75 \text{ mA}$ ,  $V_{G2} = -4.2 \text{ V}$ ,  $T = +25^\circ\text{C}$ , tested using a single-carrier, 20 MHz LTE signal with 7.8 dB PAR at 0.01% CCDF on a reference design fixture.

**Performance Plots**

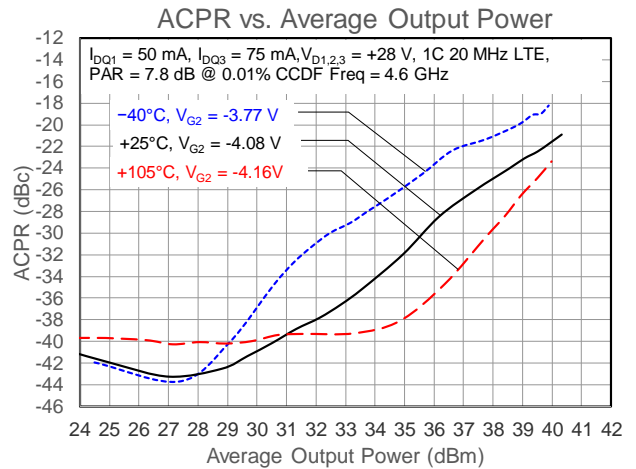
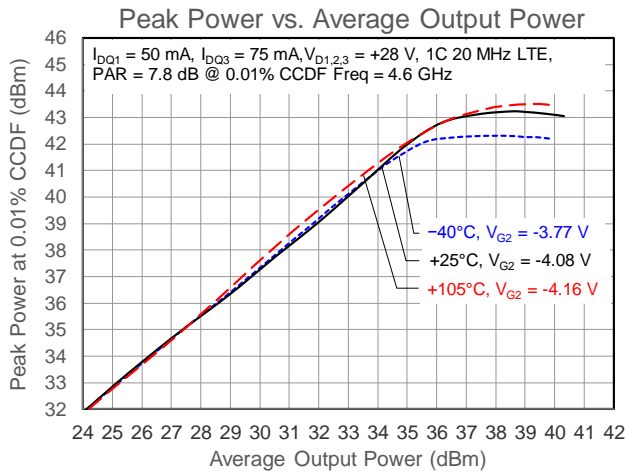
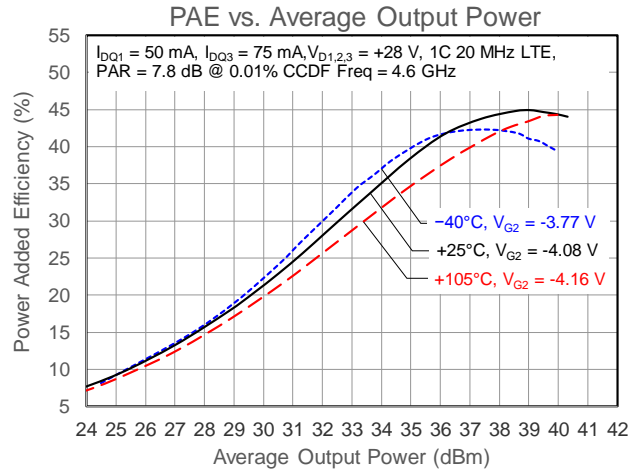
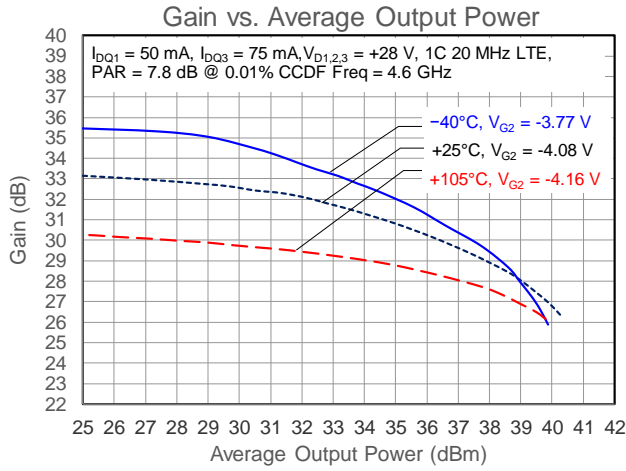

Test conditions unless otherwise noted:  $V_{D1,2,3} = +28 \text{ V}$ ,  $I_{DQ1} = 50 \text{ mA}$ ,  $I_{DQ3} = 75 \text{ mA}$ ,  $V_{G2} = -4.2 \text{ V}$ , tested at 4.6 GHz using a single-carrier, 20 MHz LTE signal with 7.8 dB PAR at 0.01% CCDF on a reference design fixture.

## Pad Configuration and Description

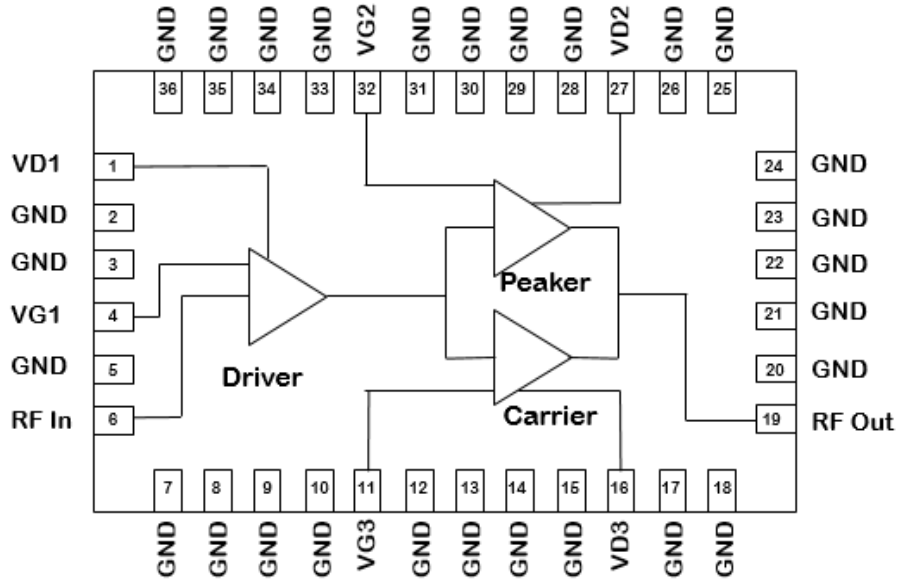

Pad No.	Label	Description
1	VD1	Driver Amplifier, Drain Bias
4	VG1	Driver Amplifier, Gate Bias
6	RF IN	RF Input
11	VG3	Carrier Amplifier, Gate Bias
16	VD3	Carrier Amplifier, Drain Bias
19	RF OUT	RF Output
27	VD2	Peaking Amplifier, Drain Bias
32	VG2	Peaking Amplifier, Gate Bias
2 – 3, 5, 7, 10, 12 – 15, 17 – 18, 20 – 26, 28 – 31, 33 – 36	GND	Internal Grounding. Recommend connecting to Epad ground.
EPAD	GND	DC/RF Ground. Must be soldered to EVB ground plane over array of vias for thermal and RF performance. Solder voids under EPAD will result in excessive junction temperatures causing permanent damage.

## Package Marking and Dimensions

Marking: Qorvo Logo  
 Part Number – QPA4501  
 Date Code – YYWW  
 Batch Code – MXXXX

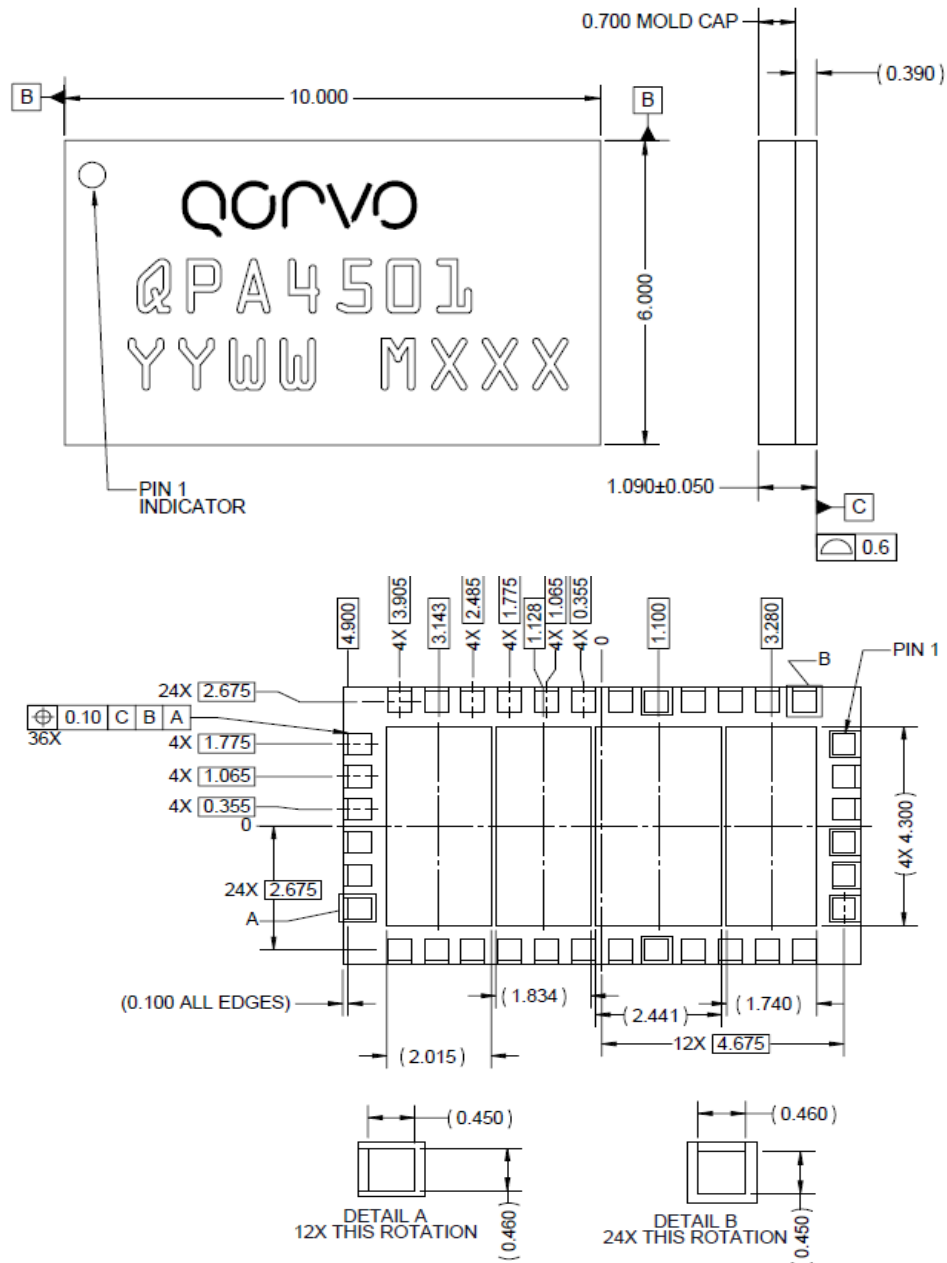

- Notes:
1. All dimensions are in millimeters. Angles are in degrees.
  2. Exposed metallization is NiPdAu plated. Au thickness is 0.095  $\mu\text{m}$ .

Mounting Footprint Pattern

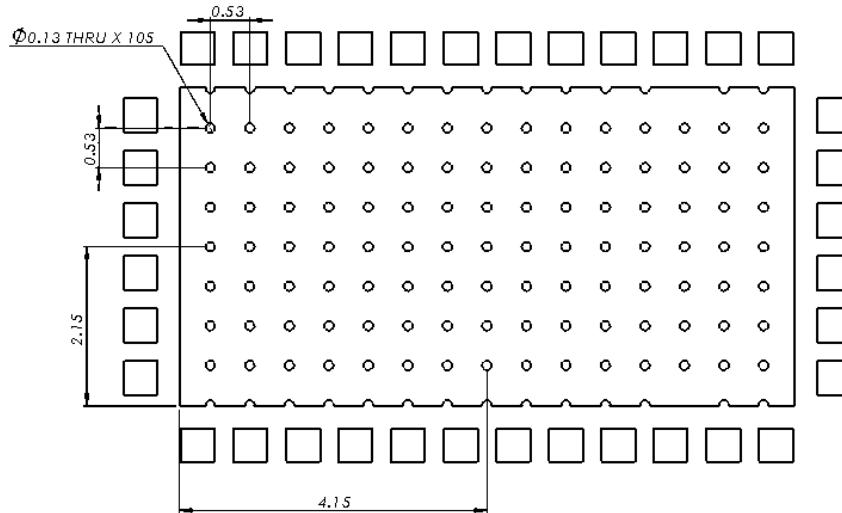

Notes:

1. All dimensions are in millimeters. Angles are in degrees.
2. Vias are required under the backside paddle of this device for proper RF/DC grounding and thermal dissipation. All vias are plated thru hole (PTH) to ground.
3. Ensure good package backside paddle solder attach for reliable operation and best electrical performance.



**Tape and Reel Information – Carrier and Cover Tape Dimensions**

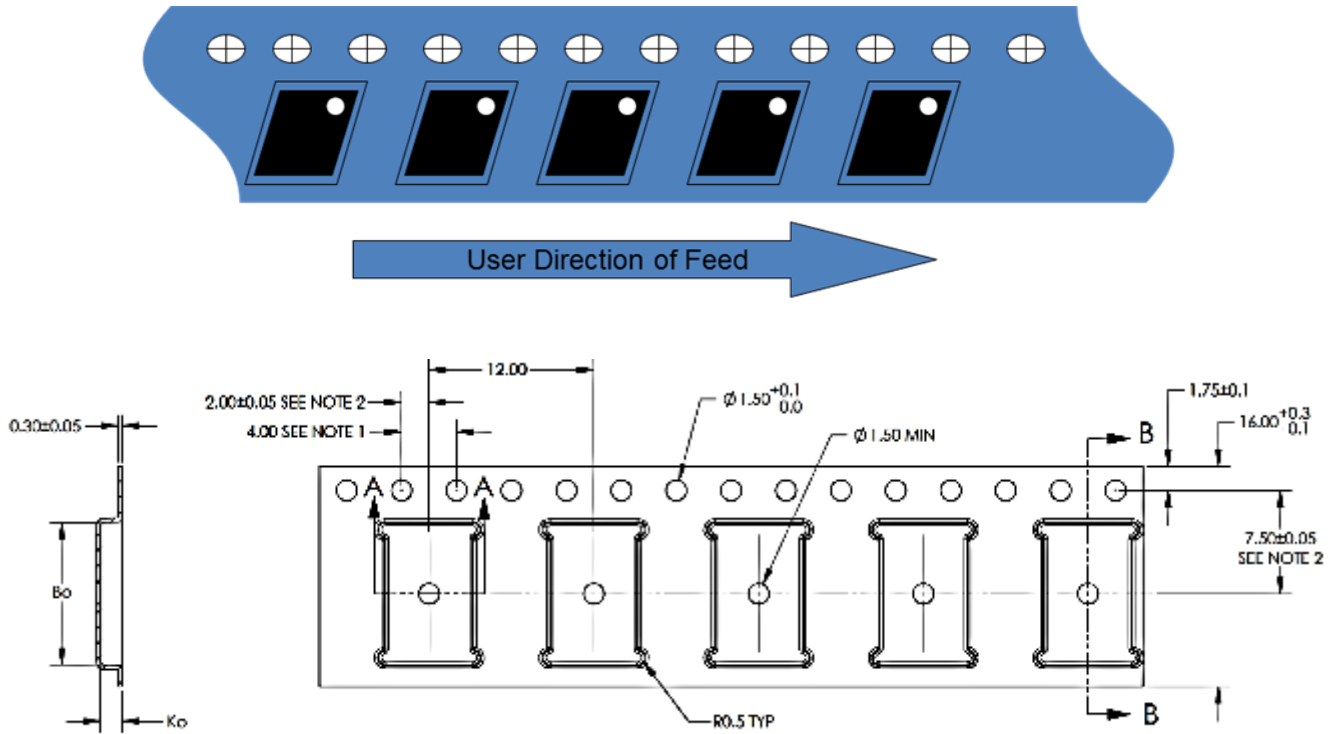

Feature	Measure	Symbol	Size (in)	Size (mm)
Cavity	Length	A0	0.248	6.30
	Width	B0	0.406	10.3
	Depth	K0	0.061	1.55
	Pitch	P1	0.472	12.0
Centerline Distance	Cavity to Perforation - Length Direction	P2	0.079	2.00
	Cavity to Perforation - Width Direction	F	0.295	7.5
Cover Tape	Width	C	0.524	13.3
Carrier Tape	Width	W	0.630	16.0

**Tape and Reel Information – Reel Dimensions**

Standard T/R size = 2,500 pieces on a 13" reel.

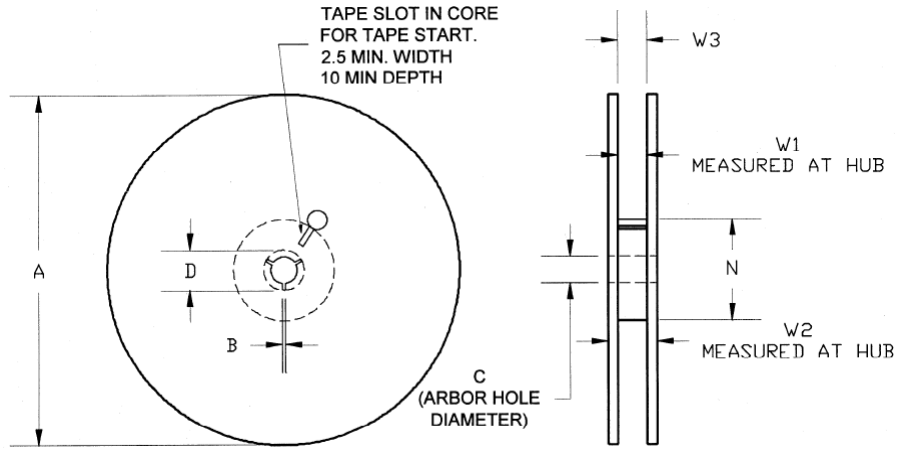

Feature	Measure	Symbol	Size (in)	Size (mm)
Flange	Diameter	A	12.992	330.0
	Thickness	W2	0.874	22.2
	Space Between Flange	W1	0.661	16.8
Hub	Outer Diameter	N	4.016	102.0
	Arbor Hole Diameter	C	0.512	13.0
	Key Slit Width	B	0.079	2.0
	Key Slit Diameter	D	0.787	20.0

**Tape and Reel Information – Tape Length and Label Placement**

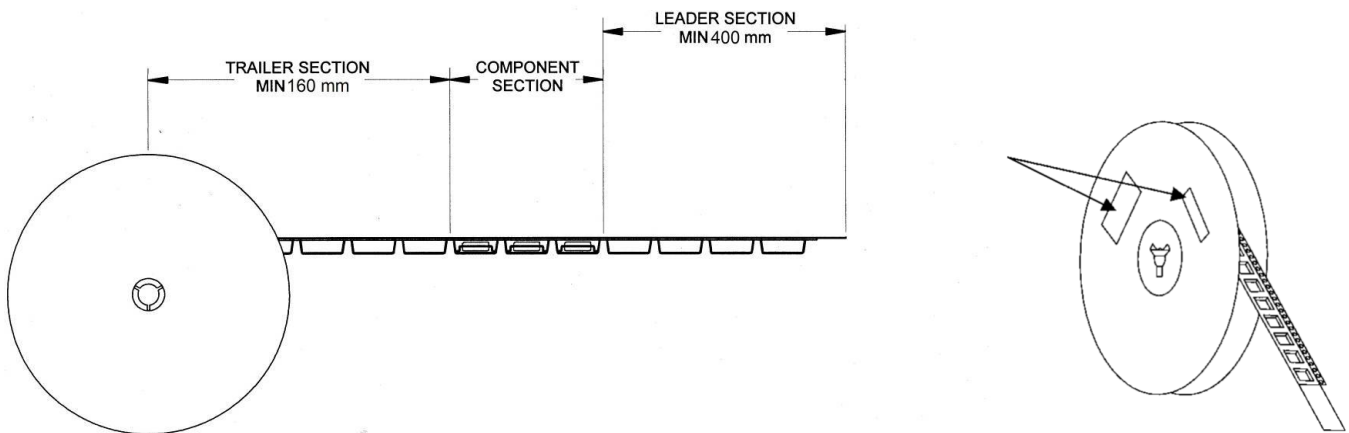

- Notes:
1. Empty part cavities at the trailing and leading ends are sealed with cover tape. See EIA 481-1-A.
  2. Labels are placed on the flange opposite the sprockets in the carrier tape.

**Recommended Solder Temperature Profile**

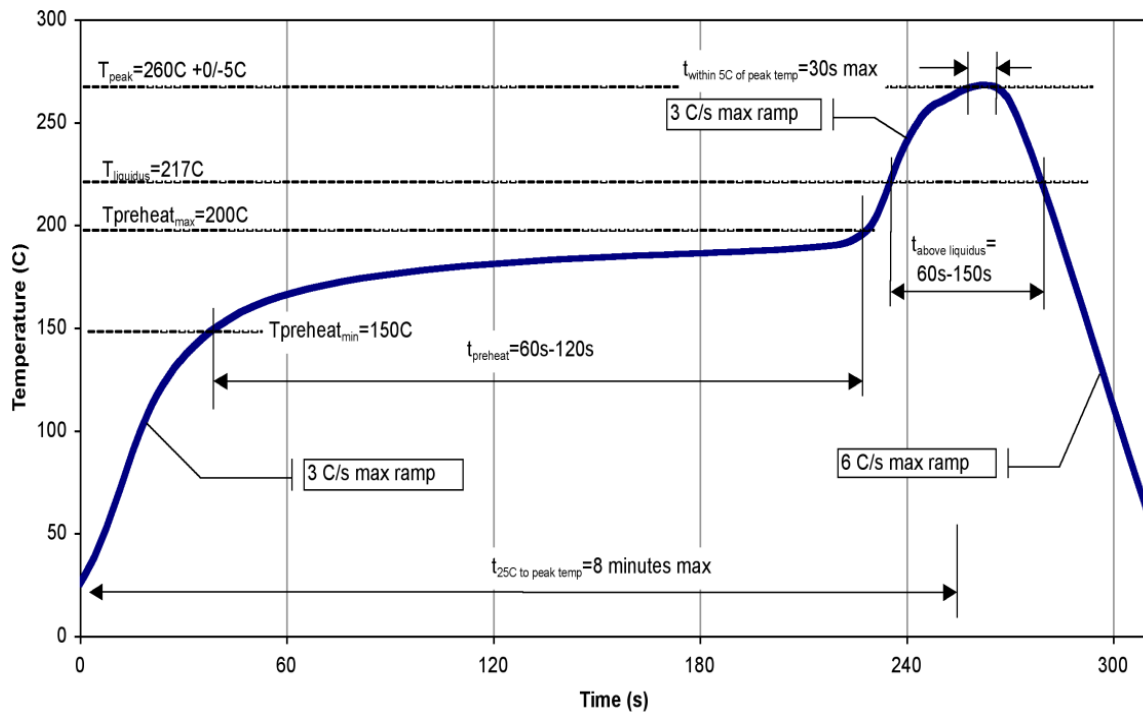

## Handling Precautions

Parameter	Rating	Standard
ESD – Human Body Model (HBM)	Class 1B (500 V)	ANSI/ESDA/JEDEC Standard JS-001
ESD – Charged Device Model (CDM)	Class C3 (1000 V)	ANSI/ESDA/JEDEC Standard JS-002
MSL – 260°C Convection Reflow	Level 3	IPC/JEDEC Standard J-STD-020



## Solderability

Compatible with lead-free (260°C max. reflow temp.) soldering processes.

Package lead plating is NiPdAu. Au thickness is 0.095 µm.

## RoHS Compliance

This part is compliant with 2011/65/EU RoHS directive (Restrictions on the Use of Certain Hazardous Substances in Electrical and Electronic Equipment) as amended by Directive 2015/863/EU.

This product also has the following attributes:

- Halogen Free (Chlorine, Bromine)
- Antimony Free
- TBBP-A (C<sub>15</sub>H<sub>12</sub>Br<sub>4</sub>O<sub>2</sub>) Free
- PFOS Free
- SVHC Free

## Contact Information

For the latest specifications, additional product information, worldwide sales and distribution locations:

**Web:** [www.qorvo.com](http://www.qorvo.com)

**Tel:** 1-844-890-8163

**Email:** [customer.support@qorvo.com](mailto:customer.support@qorvo.com)

For technical questions and application information:

**Email:** [BTSApplcations@qorvo.com](mailto:BTSApplcations@qorvo.com)

## Important Notice

The information contained herein is believed to be reliable; however, Qorvo makes no warranties regarding the information contained herein and assumes no responsibility or liability whatsoever for the use of the information contained herein. All information contained herein is subject to change without notice. Customers should obtain and verify the latest relevant information before placing orders for Qorvo products. The information contained herein or any use of such information does not grant, explicitly or implicitly, to any party any patent rights, licenses, or any other intellectual property rights, whether with regard to such information itself or anything described by such information. **THIS INFORMATION DOES NOT CONSTITUTE A WARRANTY WITH RESPECT TO THE PRODUCTS DESCRIBED HEREIN, AND QORVO HEREBY DISCLAIMS ANY AND ALL WARRANTIES WITH RESPECT TO SUCH PRODUCTS WHETHER EXPRESS OR IMPLIED BY LAW, COURSE OF DEALING, COURSE OF PERFORMANCE, USAGE OF TRADE OR OTHERWISE, INCLUDING THE IMPLIED WARRANTIES OF MERCHANTABILITY AND FITNESS FOR A PARTICULAR PURPOSE.**

Without limiting the generality of the foregoing, Qorvo products are not warranted or authorized for use as critical components in medical, life-saving, or life-sustaining applications, or other applications where a failure would reasonably be expected to cause severe personal injury or death.

Copyright 2018 © Qorvo, Inc. | Qorvo is a registered trademark of Qorvo, Inc.



## Стандарт Электрон Связь

Мы молодая и активно развивающаяся компания в области поставок электронных компонентов. Мы поставляем электронные компоненты отечественного и импортного производства напрямую от производителей и с крупнейших складов мира.

Благодаря сотрудничеству с мировыми поставщиками мы осуществляем комплексные и плановые поставки широчайшего спектра электронных компонентов.

Собственная эффективная логистика и склад в обеспечивает надежную поставку продукции в точно указанные сроки по всей России.

Мы осуществляем техническую поддержку нашим клиентам и предпродажную проверку качества продукции. На все поставляемые продукты мы предоставляем гарантию .

Осуществляем поставки продукции под контролем ВП МО РФ на предприятия военно-промышленного комплекса России , а также работаем в рамках 275 ФЗ с открытием отдельных счетов в уполномоченном банке. Система менеджмента качества компании соответствует требованиям ГОСТ ISO 9001.

Минимальные сроки поставки, гибкие цены, неограниченный ассортимент и индивидуальный подход к клиентам являются основой для выстраивания долгосрочного и эффективного сотрудничества с предприятиями радиоэлектронной промышленности, предприятиями ВПК и научно-исследовательскими институтами России.

С нами вы становитесь еще успешнее!

### Наши контакты:

**Телефон:** +7 812 627 14 35

**Электронная почта:** [sales@st-electron.ru](mailto:sales@st-electron.ru)

**Адрес:** 198099, Санкт-Петербург,  
Промышленная ул, дом № 19, литера Н,  
помещение 100-Н Офис 331