

MAX14752/MAX14753

8-Channel/Dual 4-Channel 72V Analog Multiplexers

General Description

The MAX14752/MAX14753 are 8-to-1 and dual 4-to-1 high-voltage analog multiplexers. Both devices feature 60Ω (typ) on-resistance with 0.03Ω (typ) on-resistance flatness. These low on-resistance multiplexers conduct equally well in either direction. Flexible logic levels for the channel-select interface are defined by the EN input.

The MAX14752 is a 8-to-1 multiplexer and MAX14753 is a dual 4-to-1 multiplexer. Both devices operate with dual supplies of ±10V to ±36V, or a single supply of +20V to +72V.

The MAX14752/MAX14753 are available in a 16-pin TSSOP package and are pin compatible with the industry-standard DG408/DG409. Both the MAX14752/MAX14753 are specified over the extended -40°C to +85°C operating temperature range.

Applications

- Programmable-Logic Controllers
- Environment Control Systems
- ATE Systems
- Medical Monitoring Systems

Benefits and Features

- Supply Range Accommodates Wide Voltage Applications
 - Wide ±36V (max) Bipolar Power Supply
 - High +72V (max) Single Power Supply
 - Asymmetric Bipolar Power Supply Operation
- Low Leakage Current and R_{ON} Improves System Accuracy
 - Low On-Resistance 60Ω (typ)
 - 0.03Ω (typ) R_{ON} Flatness Over Common-Mode Voltage Range
 - 20nA Low-Input, On-Leakage Current (max)
- Low 25μA I_{DD} Supply Current in Disable Mode Saves Power
- Easy to Upgrade with Pin-Compatible, Industry-Standard DG408/DG409

Ordering Information

PART	TEMP RANGE	PIN-PACKAGE
MAX14752EUE+	-40°C to +85°C	16 TSSOP
MAX14753EUE+	-40°C to +85°C	16 TSSOP

+Denotes a lead(Pb)-free/RoHS-compliant package.

Pin Configurations appear at end of data sheet.

Functional Diagrams

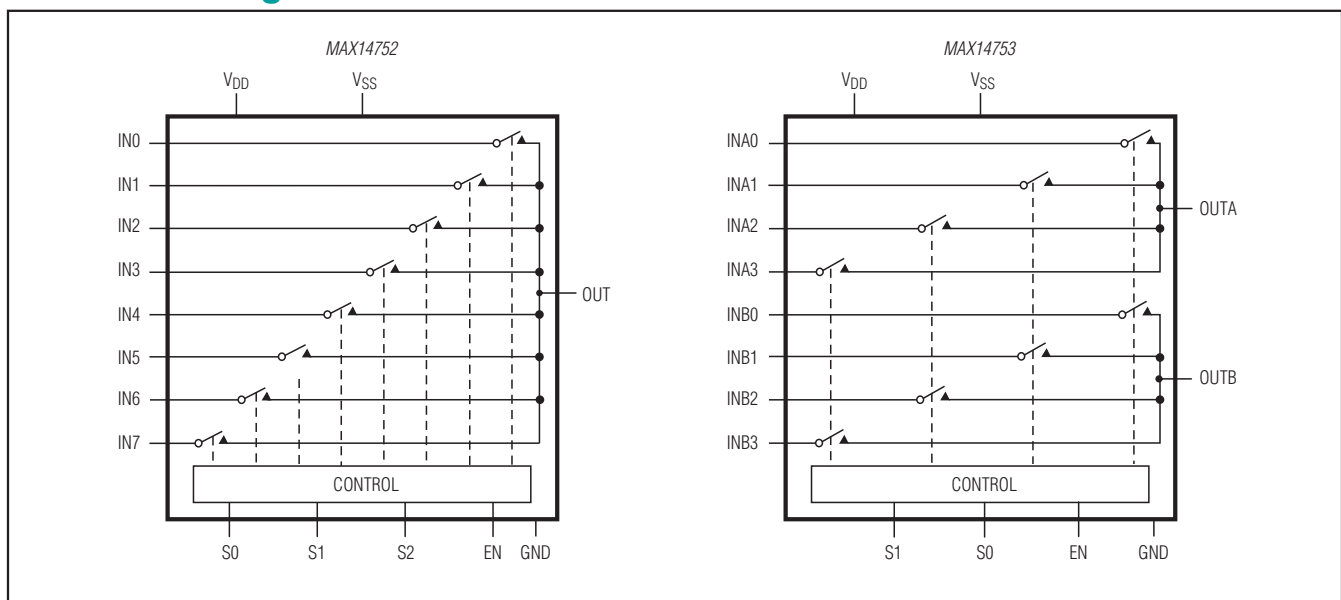

Absolute Maximum Ratings

V _{DD} to V _{SS}	-0.3V to +72V
GND to V _{SS}	-0.3V to V _{DD}
EN, S0, S1, S2 to GND	-0.3V to the lesser of (+12V and V _{DD} + 0.3V)
IN ₋ , INA ₋ , INB ₋ , OUT, OUTA, OUTB to V _{SS}	-2V to (V _{DD} - V _{SS} + 2V) or 100mA (whichever occurs first)
Continuous Current into IN ₋ , INA ₋ , INB ₋ , OUT, OUTA, OUTB	100mA
Continuous Power Dissipation (T _A = +70°C) 16-Pin TSSOP (derate 11.1mW/°C above +70°C)	890mW

Junction-to-Ambient Thermal Resistance (θ _{JA}) (Note 1) 16-Pin TSSOP	90°C/W
Junction-to-Case Thermal Resistance (θ _{JC}) (Note 1) 16-Pin TSSOP	27°C/W
Maximum Operating Temperature Range	-40°C to +125°C
Junction Temperature	+150°C
Storage Temperature Range	-65°C to +150°C
Lead Temperature (soldering, 10s)	+300°C
Soldering Temperature (reflow)	+260°C

Note 1: Package thermal resistances were obtained using the method described in JEDEC specification JESD51-7, using a four-layer board. For detailed information on package thermal considerations, refer to www.maximintegrated.com/thermal-tutorial.

Stresses beyond those listed under "Absolute Maximum Ratings" may cause permanent damage to the device. These are stress ratings only, and functional operation of the device at these or any other conditions beyond those indicated in the operational sections of the specifications is not implied. Exposure to absolute maximum rating conditions for extended periods may affect device reliability.

DC Electrical Characteristics—Dual Supplies

(V_{DD} = +35V, V_{SS} = -35V, V_{GND} = 0V, V_{EN} = +3.3V, T_A = -40°C to +85°C, unless otherwise noted. Typical values are at T_A = +25°C.)

PARAMETER	SYMBOL	CONDITIONS	MIN	TYP	MAX	UNITS
POWER SUPPLY						
V _{DD} Supply Voltage Range	V _{DD}		+10		+36	V
V _{SS} Supply Voltage Range	V _{SS}		-10		-36	V
V _{DD} Supply Current	I _{DD(OFF)}	V _{EN} = V _{S-} = 0V, V _{IN-} = V _{INA-} = V _{INB-} = +20V		12	25	μA
	I _{DD(ON)}	V _{EN} = +5V, V _{S-} = 0V or V _{EN} , V _{IN-} = V _{INA-} = V _{INB-} = +20V		270	600	
V _{SS} Supply Current	I _{SS(OFF)}	V _{EN} = V _{S-} = 0V, V _{IN-} = V _{INA-} = V _{INB-} = +20V		11	25	μA
	I _{SS(ON)}	V _{EN} = +5V, V _{S-} = 0V or V _{EN} , V _{IN-} = V _{INA-} = V _{INB-} = +20V		260	600	
ANALOG MUX						
Analog Signal Range	V _{IN-} , V _{INA-} , V _{INB-} , V _{OUT} , V _{OUTA} , V _{OUTB}		V _{SS}		V _{DD}	V
Current Through Multiplexer	I _{IN-} , I _{INA-} , I _{INB-}	V _{IN-} , V _{INA-} , V _{INB-} = ±20V	-5		+5	mA
On-Resistance	R _{ON}	I _{IN-} , I _{INA-} , I _{INB-} = 5mA; V _{IN-} , V _{INA-} , V _{INB-} , V _{OUT} , V _{OUTA} , V _{OUTB} = ±20V, Figure 1		60	130	Ω
On-Resistance Matching Between Channels	ΔR _{ON}	I _{IN-} , I _{INA-} , I _{INB-} = 5mA, V _{IN-} , V _{INA-} , V _{INB-} = ±20V, 0V		0.5		Ω
On-Resistance Flatness	R _{FLAT-(ON)}	I _{IN-} , I _{INA-} , I _{INB-} = 5mA, V _{IN-} , V _{INA-} , V _{INB-} , V _{OUT} , V _{OUTA} , V _{OUTB} = ±20V		0.03		Ω
Output On-Leakage Current	I _{OUT(ON)}	MAX14752: V _{OUT} , V _{OUTA} , V _{OUTB} = ±20V, V _{IN-} , V _{INA-} , V _{INB-} = unconnected, Figure 2	-20		+20	nA
		MAX14753: V _{OUT} , V _{OUTA} , V _{OUTB} = ±20V, V _{IN-} , V _{INA-} , V _{INB-} = unconnected, Figure 2	-10		+10	

DC Electrical Characteristics—Dual Supplies (continued)(V_{DD} = +35V, V_{SS} = -35V, V_{GND} = 0V, V_{EN} = +3.3V, T_A = -40°C to +85°C, unless otherwise noted. Typical values are at T_A = +25°C.)

PARAMETER	SYMBOL	CONDITIONS	MIN	TYP	MAX	UNITS
Output Off-Leakage Current	I _{OUT(OFF)}	MAX14752: V _{OUT} , V _{OUTA} , V _{OUTB} = ±20V, V _{IN_} , V _{INA_} , V _{INB_} = -20V, Figure 3	-20		+20	nA
		MAX14753: V _{OUT} , V _{OUTA} , V _{OUTB} = ±40V, V _{IN_} , V _{INA_} , V _{INB_} = -40V, Figure 3	-10		+10	
Input Off-Leakage Current	I _{IN(OFF)}	V _{OUT} , V _{OUTA} , V _{OUTB} = ±20V, V _{IN_} , V _{INA_} , V _{INB_} = ±20V, Figure 3	-5		+5	nA
LOGIC (EN, S0, S1, S2)						
EN Input Voltage Low	V _{EN_IL}				0.8	V
EN Input Voltage High	V _{EN_IH}		2.1			V
EN, S ₀ Input Voltage Range	V _{EN} , V _{S_}				11	V
EN Input Current	I _{EN_IH(DC)}	V _{EN} = +11V, V _{S0} = V _{S1} = V _{S2} = (0.25 × V _{EN}) or (0.75 × V _{EN})			0.4	mA
S0, S1, S2 Input Voltage Low	V _{IL}				0.25 × V _{EN}	V
S0, S1, S2 Input Voltage High	V _{IH}		0.75 × V _{EN}			V
DYNAMIC CHARACTERISTICS						
Enable Turn-On Time	t _{ON}	V _{IN0} , V _{INA0} = ±10V, R _L = 10kΩ, Figure 4		1	25	μs
Enable Turn-Off Time	t _{OFF}	V _{IN0} , V _{INA0} = ±10V, R _L = 10kΩ, Figure 4		0.8	2	μs
Transition Time	t _{TRANS}	V _{IN0} , V _{INA0} = ±10V, R _L = 10kΩ, Figure 5		10		μs
Break-Before-Make Time Delay	t _{BBM}	V _{IN_} , V _{INA_} , V _{INB_} = ±10V, R _L = 10kΩ, Figure 6		10		μs
Frequency Response	BW	R _S = 50Ω, R _L = 1kΩ, Figure 7			20	MHz
Off-Isolation	V _{ISO}	V _{IN_} , V _{INA_} , V _{INB_} = 1V _{RMS} , f = 100kHz, R _L = 50Ω, C _L = 15pF, Figure 8		65		dB
Crosstalk	V _{CT}	R _S = R _L = 50Ω, Figure 9		62		dB
Total Harmonic Distortion Plus Noise	THD+N	R _S = R _L = 1kΩ, f = 20Hz to 20kHz		0.0014		%
Charge Injection	Q	V _{IN_} , V _{INA_} , V _{INB_} = GND, C _L = 1nF, Figure 10		200		pC

DC Electrical Characteristics—Single Supply(V_{DD} = +70V, V_{SS} = V_{GND} = 0V, V_{EN} = +3.3V, T_A = -40°C to +85°C, unless otherwise noted. Typical values are at T_A = +25°C.) (Note 2)

PARAMETER	SYMBOL	CONDITIONS	MIN	TYP	MAX	UNITS
On-Resistance	R _{ON}	I _{IN_} = 5mA, V _{IN_} , V _{OUT} = +20V (MAX14752), V _{INA_} , V _{OUTA} , V _{INB_} , V _{OUTB} = +20V (MAX14753), Figure 1		60	130	
OUT, OUTA, OUTB Off-Leakage Current	I _{OUT(OFF)} , I _{OUTA(OFF)} , I _{OUTB(OFF)}	MAX14752: V _{OUT} = +40V, V _{IN_} = V _{INA_} = V _{INB_} = +10V, Figure 3	20		+20	nA
		MAX14753: V _{OUT} = +40V, V _{IN_} = V _{INA_} = V _{INB_} = +10V, Figure 3	-10		+10	
On-Input Capacitance	C _{IN_ON}	MAX14752, V _{DD} = +50V, OUT unconnected	V _{IN_} = 4V		43	pF
			V _{IN_} = 25V		26	
		MAX14753, V _{DD} = +50V, OUTA, OUTB unconnected	V _{INA_} , V _{INB_} = 4V		26	
			V _{INA_} , V _{INB_} = 25V		16	
Off-Input Capacitance	C _{IN_OFF}	MAX14752, V _{DD} = +50V	V _{IN_} = 4V		6	pF
			V _{IN_} = 25V		3.7	
		MAX14753, V _{DD} = +50V	V _{INA_} , V _{INB_} = 4V		6	
			V _{INA_} , V _{INB_} = 25V		3.7	
Off-Output Capacitance	C _{OUT_OFF}	MAX14752, V _{DD} = +50V	V _{OUT_} = 4V		35	pF
			V _{OUT_} = 25V		20	
		MAX14753, V _{DD} = +50V	V _{OUTA_} , V _{OUTB_} = 4V		19	
			V _{OUTA_} , V _{OUTB_} = 25V		11	

Note 2: All parameters in single-supply operation are expected to be the same as in dual-supplies operation.**Note 3:** IN-OUT capacitances are negligible (< 1pF).

Test Circuits/Timing Diagrams/Truth Tables

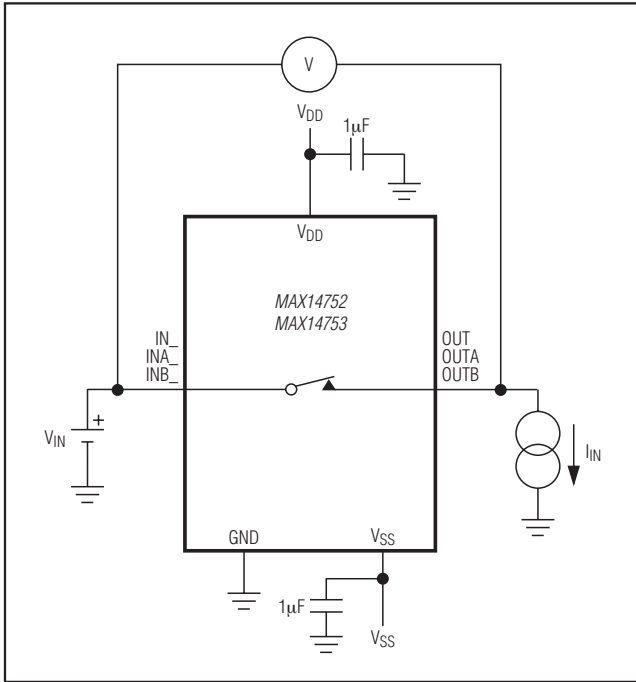

Figure 1. On-Resistance

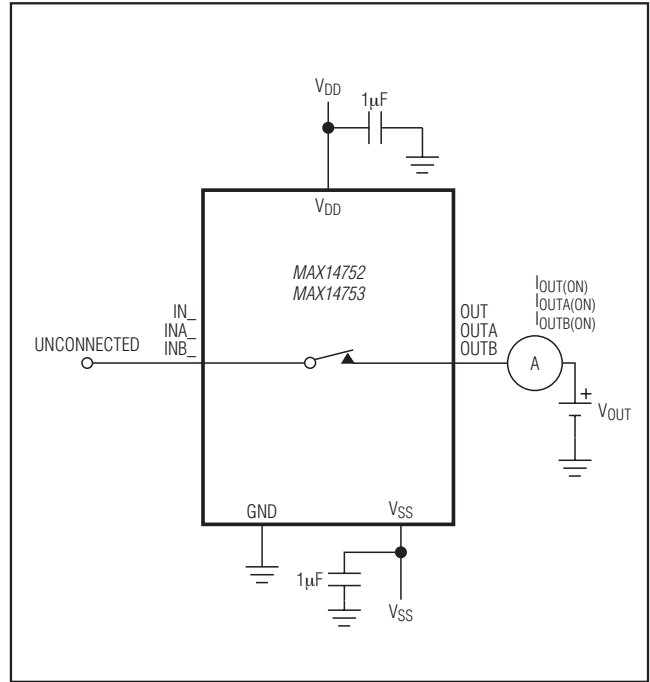

Figure 2. On-Leakage Current

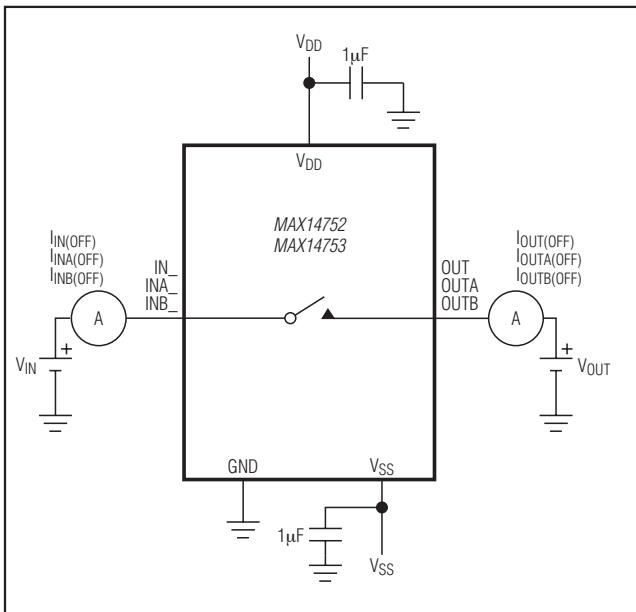

Figure 3. Off-Leakage Current

Test Circuits/Timing Diagrams/Truth Tables (continued)

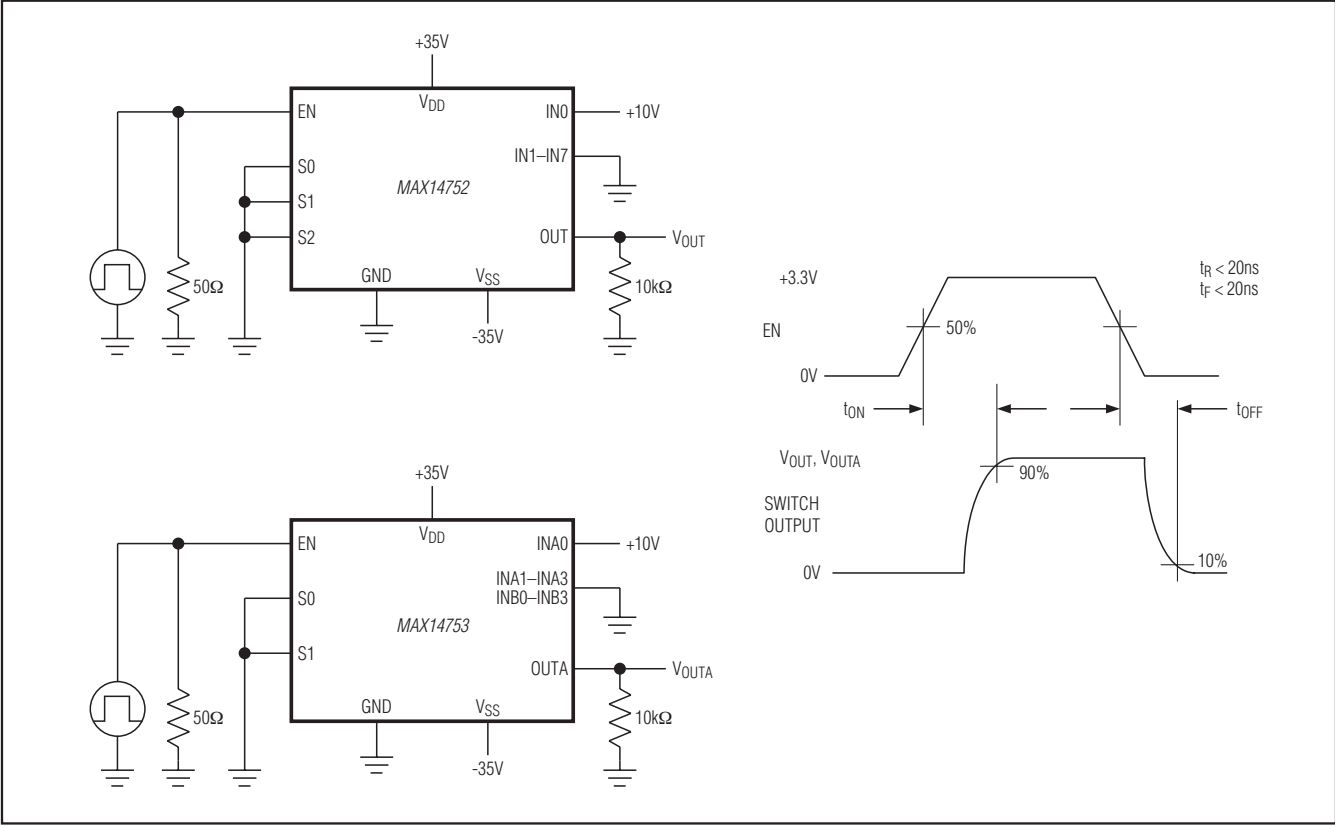

Figure 4. Enable Switching Time

Test Circuits/Timing Diagrams/Truth Tables (continued)

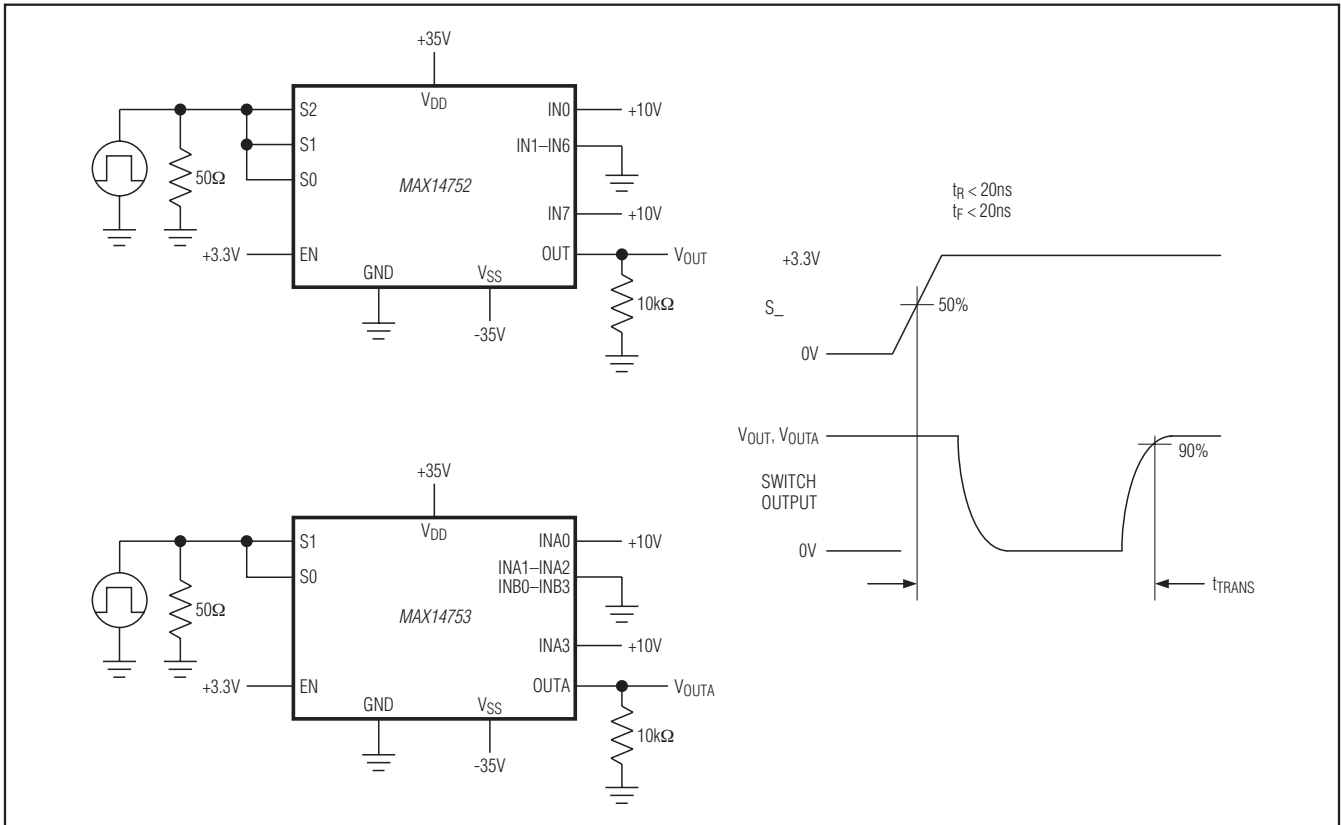

Figure 5. Transition Time

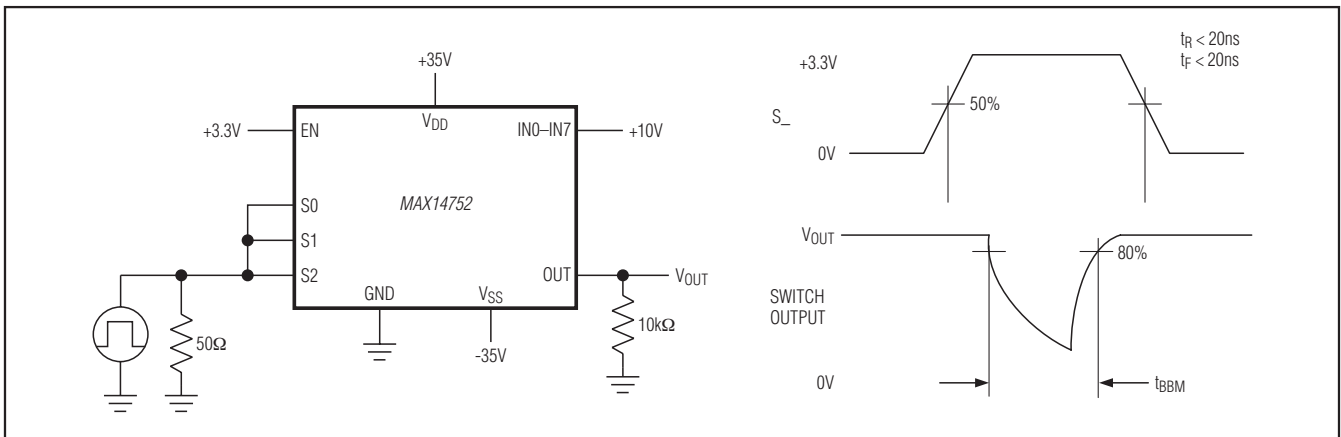

Figure 6. Break-Before-Make Interval

Test Circuits/Timing Diagrams/Truth Tables (continued)

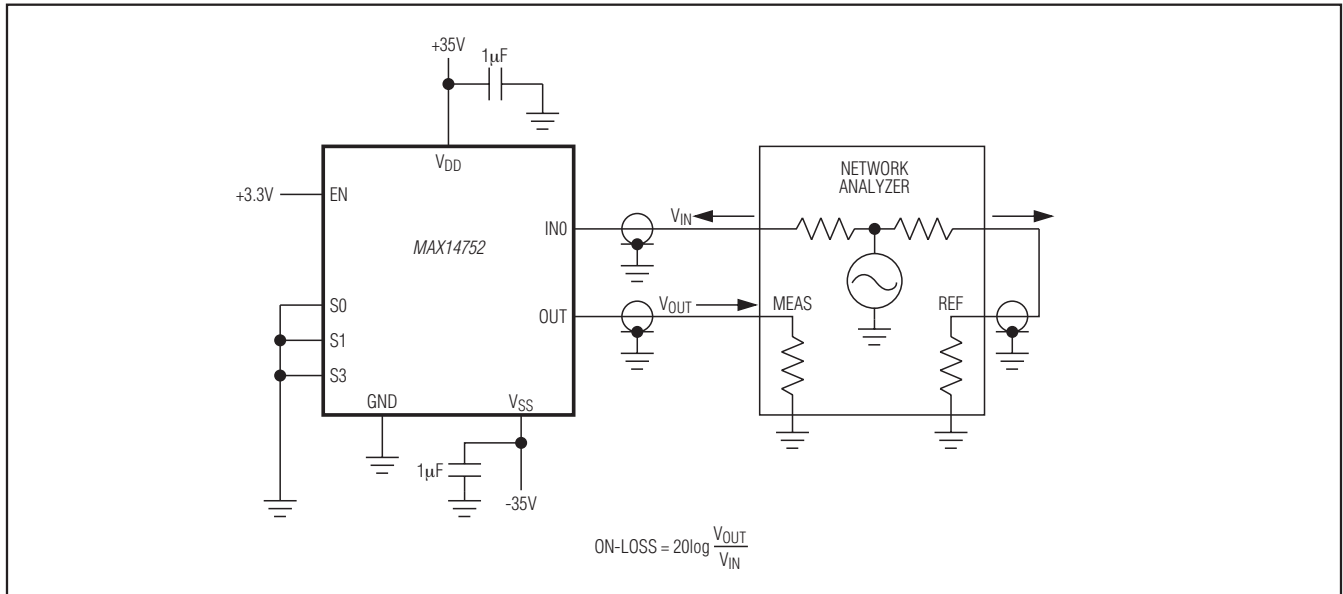

Figure 7. Frequency Response

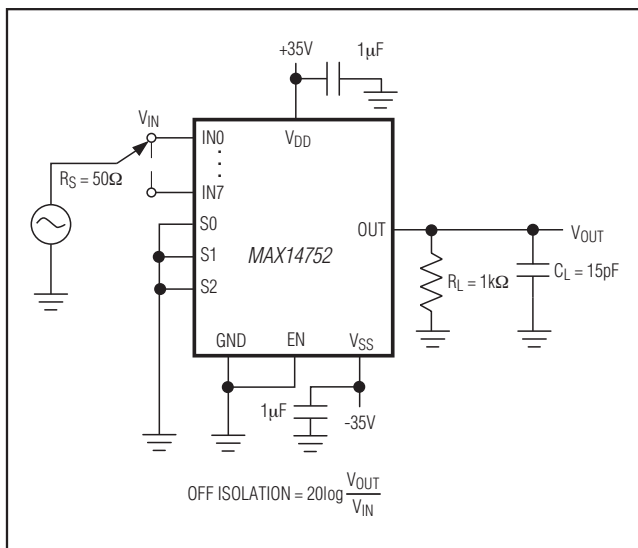

Figure 8. Off-Isolation

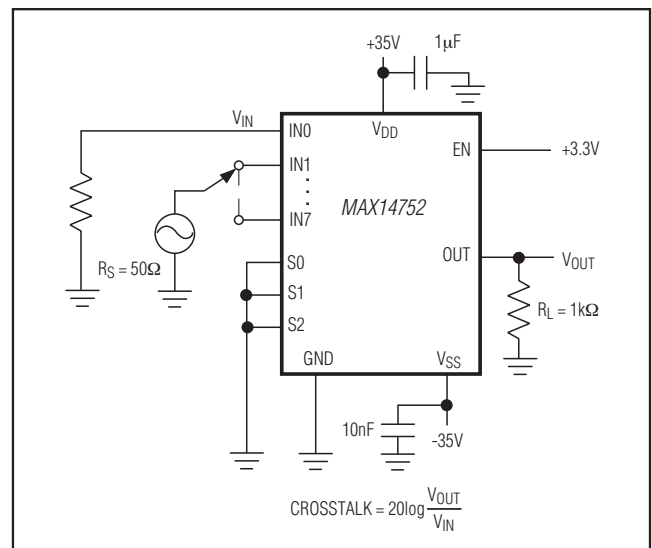

Figure 9. Crosstalk

Test Circuits/Timing Diagrams/Truth Tables (continued)

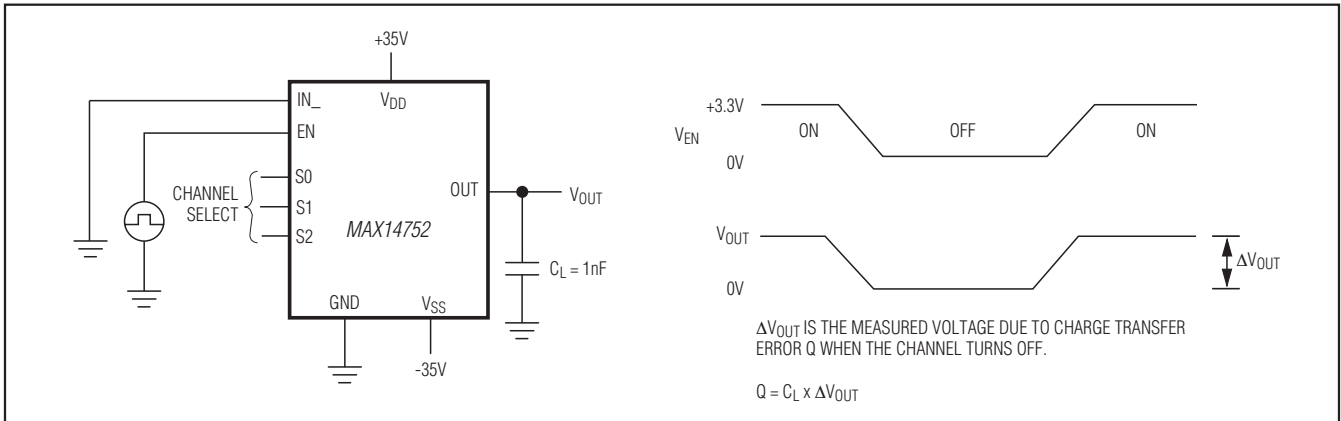

Figure 10. Charge Injection

Table 1. MAX14752 Truth Table

S2	S1	S0	EN	OUT
X	X	X	0	All off
0	0	0	1	IN0
0	0	1	1	IN1
0	1	0	1	IN2
0	1	1	1	IN3
1	0	0	1	IN4
1	0	1	1	IN5
1	1	0	1	IN6
1	1	1	1	IN7

Table 2. MAX14753 Truth Table

S1	S0	EN	OUTA	OUTB
X	X	0	All off	All off
0	0	1	INA0	INB0
0	1	1	INA1	INB1
1	0	1	INA2	INB2
1	1	1	INA3	INB3

Typical Operating Characteristics

($T_A = +25^\circ\text{C}$, unless otherwise noted.)

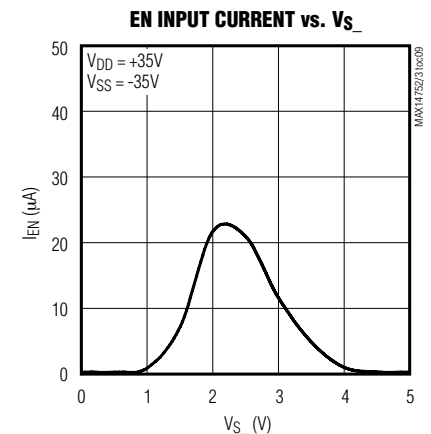
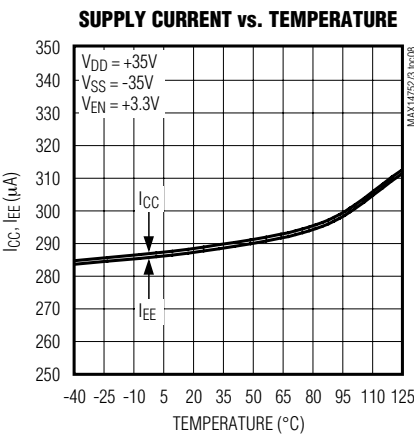
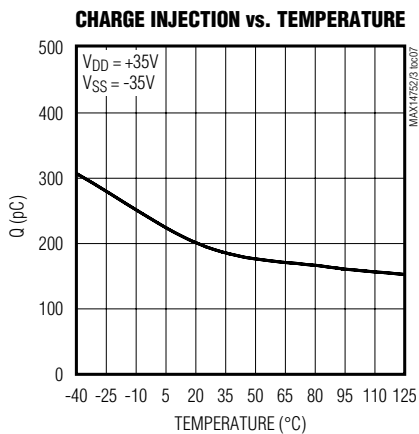
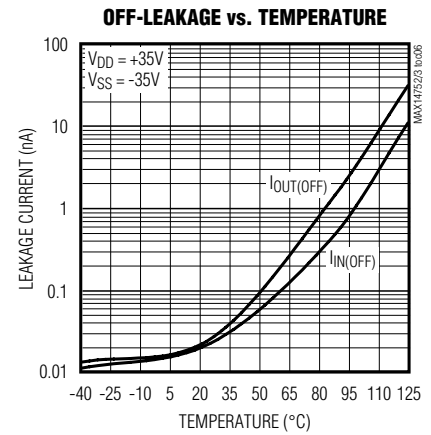
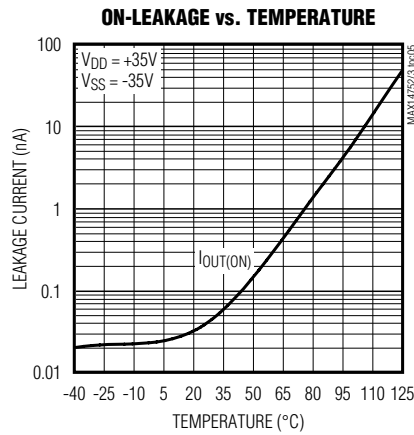
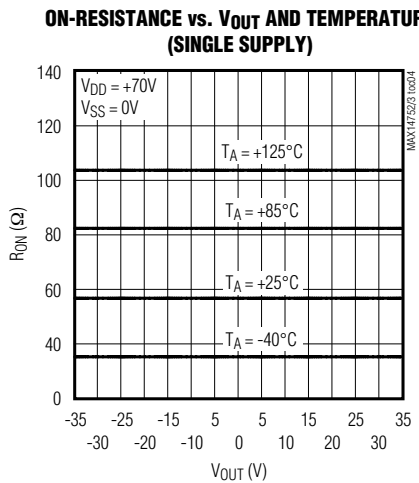
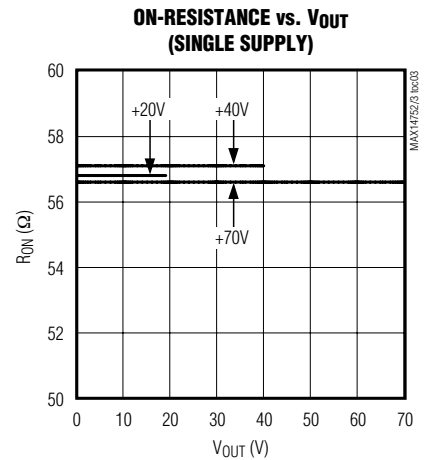
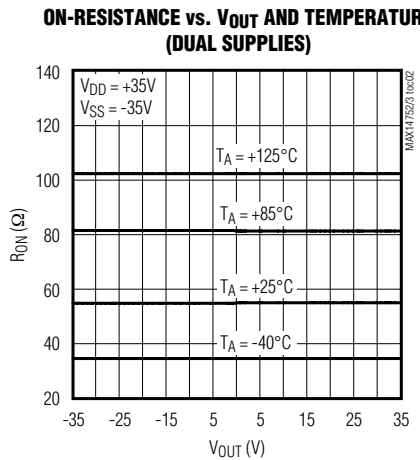
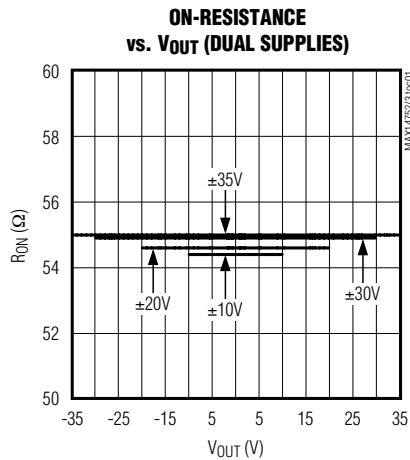

Typical Operating Characteristics (continued)

(T_A = +25°C, unless otherwise noted.)

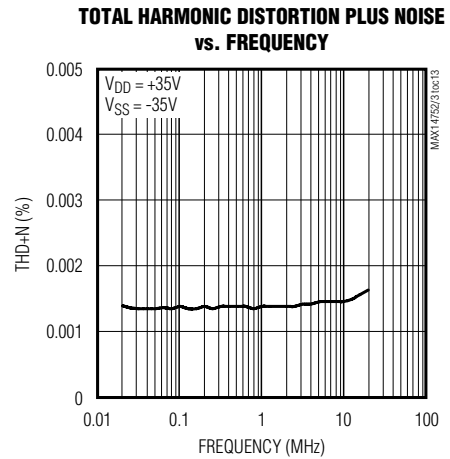
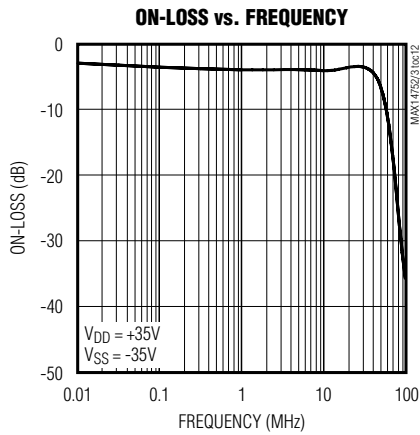
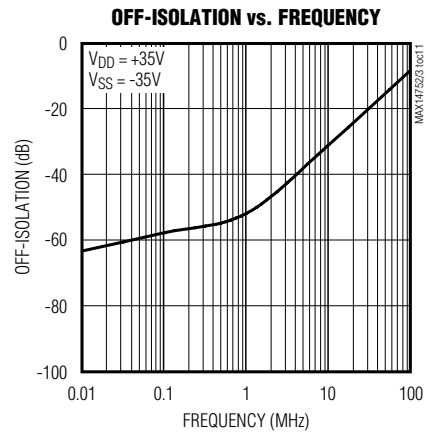
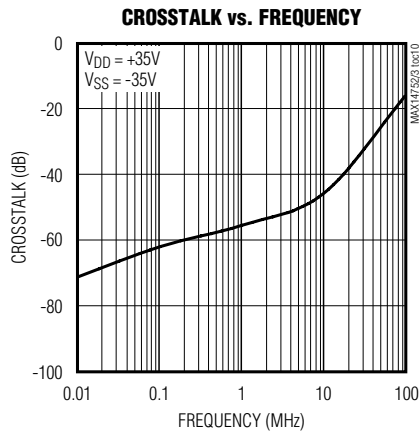

MAX14752 Pin Description (Single 8-to-1 Mux)

PIN	NAME	FUNCTION
1	S0	Mux Input Select
2	EN	Mux Enable. Drive EN high to enable the device. The EN high voltage defines input logic voltage level for S0, S1, and S2.
3	V _{SS}	Negative Supply Voltage. Bypass V _{SS} to GND with a 1 μ F ceramic capacitor.
4	IN0	Bidirectional Analog Input
5	IN1	Bidirectional Analog Input
6	IN2	Bidirectional Analog Input
7	IN3	Bidirectional Analog Input
8	OUT	Bidirectional Analog Output
9	IN7	Bidirectional Analog Input
10	IN6	Bidirectional Analog Input
11	IN5	Bidirectional Analog Input
12	IN4	Bidirectional Analog Input
13	V _{DD}	Positive Supply Voltage. Bypass V _{DD} to GND with a 1 μ F ceramic capacitor.
14	GND	Ground. Connect GND to V _{SS} for single supply. Bypass GND to V _{SS} with a 1 μ F ceramic capacitor for dual supply.
15	S2	Mux Input Select
16	S1	Mux Input Select

MAX14753 Pin Description (Dual 4-to-1 Mux)

PIN	NAME	FUNCTION
1	S0	Mux Input Select
2	EN	Mux Enable. Drive EN high to enable the device. The EN high voltage defines input logic voltage level for S0 and S1.
3	V _{SS}	Negative Supply Voltage. Bypass V _{SS} to GND with a 1 μ F ceramic capacitor.
4	INA0	Bidirectional Analog Input
5	INA1	Bidirectional Analog Input
6	INA2	Bidirectional Analog Input
7	INA3	Bidirectional Analog Input
8	OUTA	Bidirectional Analog Output
9	OUTB	Bidirectional Analog Output
10	INB3	Bidirectional Analog Input
11	INB2	Bidirectional Analog Input
12	INB1	Bidirectional Analog Input
13	INB0	Bidirectional Analog Input
14	V _{DD}	Positive Supply Voltage. Bypass V _{DD} to GND with a 1 μ F ceramic capacitor.
15	GND	Ground. Connect GND to V _{SS} for single supply. Bypass GND to V _{SS} with a 1 μ F ceramic capacitor for dual supply.
16	S1	Mux Input Select

Detailed Description

The MAX14752/MAX14753 are 8-to-1 and dual 4-to-1 high-voltage analog multiplexers. Both devices feature 60Ω (typ) on-resistance with 0.03Ω (typ) on-resistance flatness. These low on-resistance multiplexers conduct equally well in either direction.

The MAX14752 is an 8-to-1 multiplexer and MAX14753 is a dual 4-to-1 multiplexer. Both devices operate with dual supplies of ±10V to ±36V or a single supply of +20V to +72V. Both devices can also operate with unbalanced supplies, such as +36V and -10V. These multiplexers support rail-to-rail input and output signals. The control logic level is defined via the EN input. These devices do not require power-supply sequencing.

Applications Information

Current Through the Mux

The current flowing through each on-channel of the MAX14752/MAX14753 multiplexers must be limited to ±5mA for normal operation. If the current exceeds this limit, an internal leakage current from that channel to VSS appears. Larger input current does not destroy the device if the max power dissipation is not exceeded.

Input Voltage Clamping

For applications that require input voltages beyond the normal operating voltages, the internal input diodes to VDD and VSS can be used to limit the input voltages. As shown in Figure 11, series resistors can be employed at the inputs to limit the currents flowing into the diodes during undervoltage and overvoltage conditions. Choose the

limiting resistors such that the input currents are limited to $I_{IN_}(max) = 100mA$. The values of the current limit resistors can be calculated as the larger of R_{LIM+} and R_{LIM-} .

$$R_{LIM+} = \frac{V_{IN_}(max) - V_{DD}}{I_{IN_}(max)}$$

$$R_{LIM-} = \frac{V_{SS} - V_{IN_}(min)}{I_{IN_}(max)}$$

During an undervoltage or overvoltage condition, the input impedance is equal to R_{LIM} . The additional power dissipation due to the fault currents needs to be calculated. The MAX14752/MAX14753 multiplexer operates normally on a channel that is on during an overvoltage or undervoltage clamping condition on a second channel that is not switched.

Beyond-the-Rail Input

If input voltages are expected to go beyond the supply voltages, but within the absolute maximum supply voltages of the MAX14752/MAX14753, add two diodes in series with the supplies as shown in Figure 12.

During undervoltage and overvoltage events, the internal diodes pull VDD/VSS supplies up/down. An advantage of this scheme is that the input impedance is high and currents do not flow through the MAX14752/MAX14753 during overvoltage and undervoltage events. The input voltages must be limited to the voltages specified in the *Absolute Maximum Ratings* section.

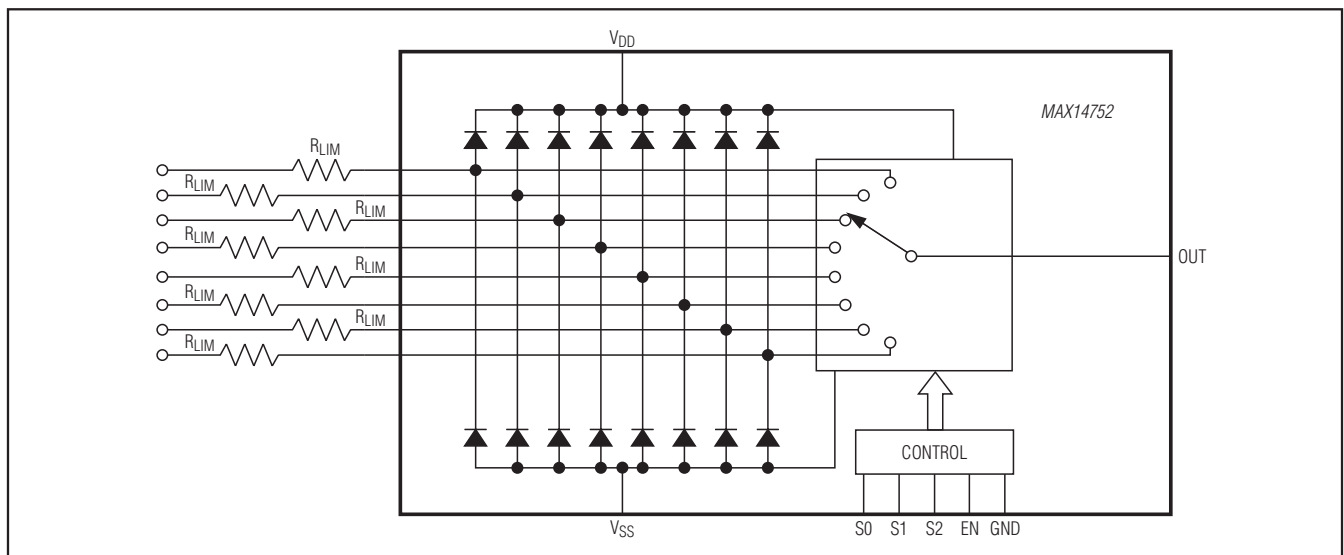

Figure 11. Input Overvoltage and Undervoltage Clamping

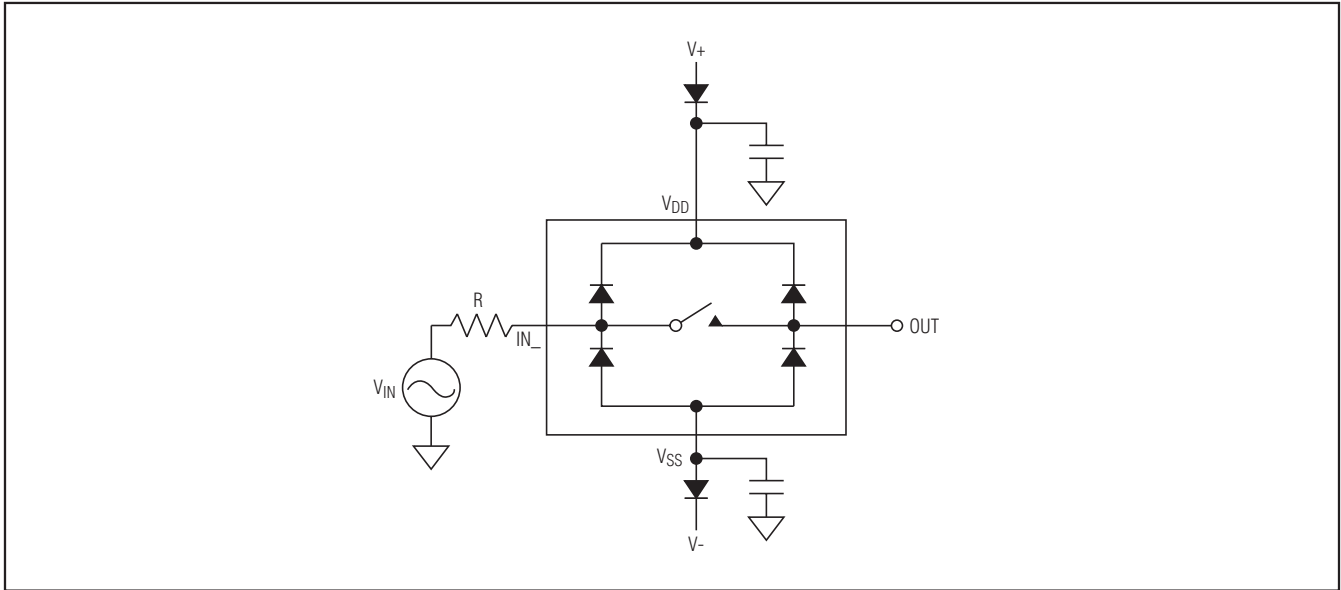
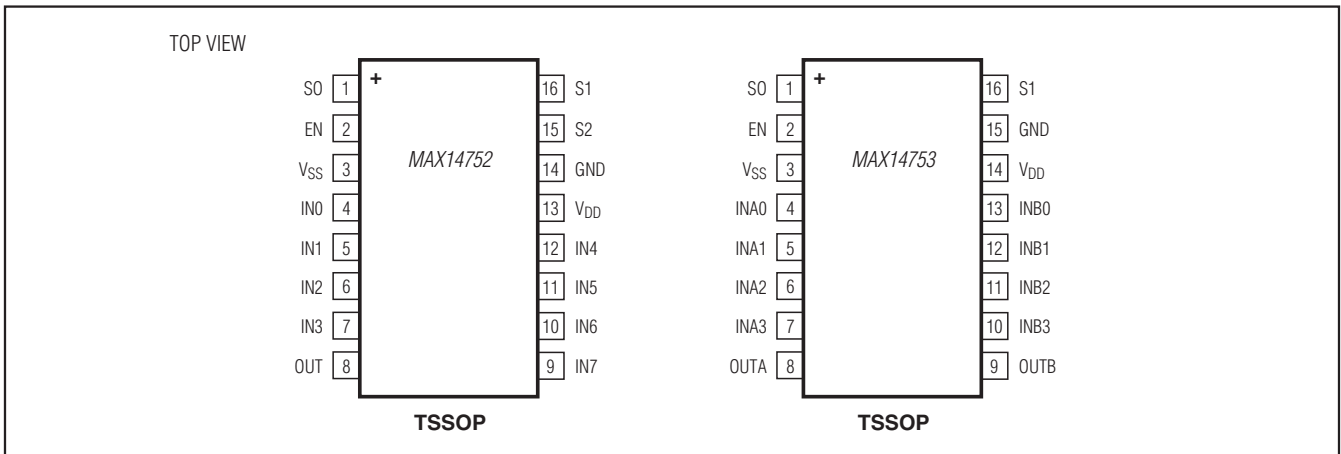

Figure 12. Beyond-the-Rail Application

Pin Configurations



Chip Information

PROCESS: CMOS

Package Information

For the latest package outline information and land patterns (footprints), go to www.maximintegrated.com/packages. Note that a “+”, “#”, or “-” in the package code indicates RoHS status only. Package drawings may show a different suffix character, but the drawing pertains to the package regardless of RoHS status.

PACKAGE TYPE	PACKAGE CODE	OUTLINE NO.	LAND PATTERN NO.
16 TSSOP	U16+1	21-0066	90-0117

Revision History

REVISION NUMBER	REVISION DATE	DESCRIPTION	PAGES CHANGED
0	8/08	Initial release	—
1	10/08	Changed the units from mA to μ A for V_{DD} and V_{SS} supply current in the <i>DC Electrical Characteristics—Dual Supplies</i> table	2
2	2/09	Added capacitance information to EC table	2, 4, 13, 14, 15, 16
3	7/10	Deleted the “Input Capacitance” parameter from the <i>DC Electrical Characteristics—Dual Supplies</i>	3
4	4/15	Removed automotive reference	1
5	5/15	Revised <i>Benefits and Features</i> section	1

For pricing, delivery, and ordering information, please contact Maxim Direct at 1-888-629-4642, or visit Maxim Integrated's website at www.maximintegrated.com.

Maxim Integrated cannot assume responsibility for use of any circuitry other than circuitry entirely embodied in a Maxim Integrated product. No circuit patent licenses are implied. Maxim Integrated reserves the right to change the circuitry and specifications without notice at any time. The parametric values (min and max limits) shown in the Electrical Characteristics table are guaranteed. Other parametric values quoted in this data sheet are provided for guidance.



Стандарт Электрон Связь

Мы молодая и активно развивающаяся компания в области поставок электронных компонентов. Мы поставляем электронные компоненты отечественного и импортного производства напрямую от производителей и с крупнейших складов мира.

Благодаря сотрудничеству с мировыми поставщиками мы осуществляем комплексные и плановые поставки широчайшего спектра электронных компонентов.

Собственная эффективная логистика и склад в обеспечивает надежную поставку продукции в точно указанные сроки по всей России.

Мы осуществляем техническую поддержку нашим клиентам и предпродажную проверку качества продукции. На все поставляемые продукты мы предоставляем гарантию .

Осуществляем поставки продукции под контролем ВП МО РФ на предприятия военно-промышленного комплекса России , а также работаем в рамках 275 ФЗ с открытием отдельных счетов в уполномоченном банке. Система менеджмента качества компании соответствует требованиям ГОСТ ISO 9001.

Минимальные сроки поставки, гибкие цены, неограниченный ассортимент и индивидуальный подход к клиентам являются основой для выстраивания долгосрочного и эффективного сотрудничества с предприятиями радиоэлектронной промышленности, предприятиями ВПК и научно-исследовательскими институтами России.

С нами вы становитесь еще успешнее!

Наши контакты:

Телефон: +7 812 627 14 35

Электронная почта: sales@st-electron.ru

Адрес: 198099, Санкт-Петербург,
Промышленная ул, дом № 19, литера Н,
помещение 100-Н Офис 331