



Precision Edge®

## FEATURES

- **Guaranteed AC performance over temperature and voltage:**
  - DC-to > 2GHz throughput
  - <600ps propagation delay (IN-to-Q)
  - <20ps within-device skew
  - <190ps rise/fall times
- **Ultra-low jitter design**
  - <1ps<sub>RMS</sub> cycle-to-cycle jitter
  - <10ps<sub>PP</sub> total jitter
  - <1ps<sub>RMS</sub> random jitter
  - <10ps<sub>PP</sub> deterministic jitter
- **Unique input termination and VT pin accepts DC- and AC-coupled inputs**
- **High-speed LVDS outputs**
- **3.3V power supply operation**
- **Industrial temperature range: -40°C to +85°C**
- **Available in 16-pin (3mm x 3mm) MLF® package**

## APPLICATIONS

- **Processor clock distribution**
- **SONET clock distribution**
- **Fibre Channel clock distribution**
- **Gigabit Ethernet clock distribution**

## FUNCTIONAL BLOCK DIAGRAM

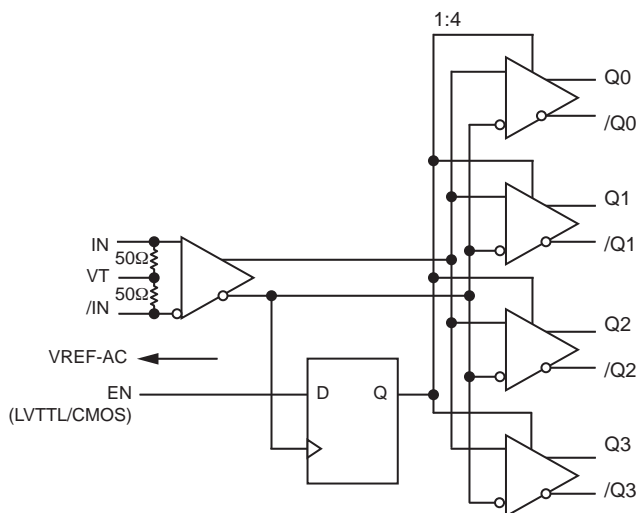

## DESCRIPTION

The SY89833L is a 3.3V, high-speed 2GHz differential Low Voltage Differential Swing (LVDS) 1:4 fanout buffer optimized for ultra-low skew applications. Within device skew is guaranteed to be less than 20ps over supply voltage and temperature.

The differential input buffer has a unique internal termination design that allows access to the termination network through a VT pin. This feature allows the device to easily interface to different logic standards. A VREF-AC reference is included for AC-coupled applications.

The SY89833L is part of Micrel's high-speed clock synchronization family. For 2.5V applications, the SY89832U provides similar functionality while operating from a 2.5V ±5% supply. For applications that require a different I/O combination, consult the Micrel website at: [www.micrel.com](http://www.micrel.com), and choose from a comprehensive product line of high-speed, low-skew fanout buffers, translators and clock generators.

## TYPICAL PERFORMANCE

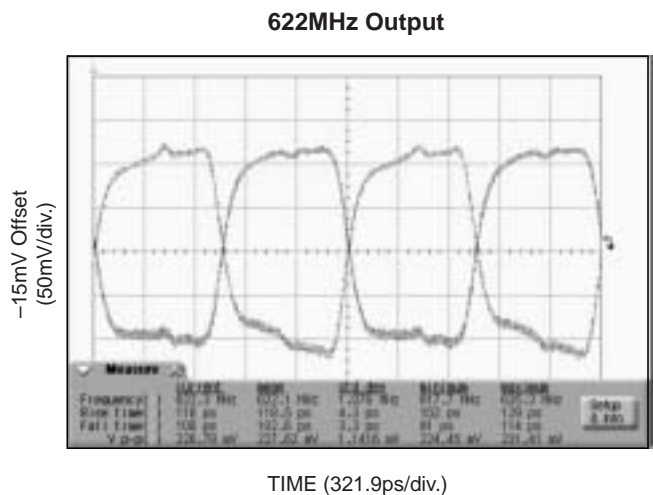

**PACKAGE/ORDERING INFORMATION**

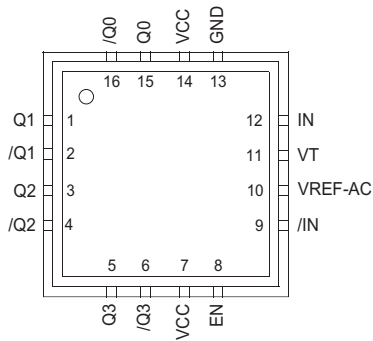

**16-Pin MLF® (MLF-16)**

**Ordering Information<sup>(1)</sup>**

Part Number	Package Type	Operating Range	Package Marking	Lead Finish
SY89833LMI	MLF-16	Industrial	833L	Sn-Pb
SY89833LMITR <sup>(2)</sup>	MLF-16	Industrial	833L	Sn-Pb
SY89833LMG <sup>(3)</sup>	MLF-16	Industrial	833L with Pb-Free bar line indicator	NiPdAu Pb-Free
SY89833LMGTR <sup>(2, 3)</sup>	MLF-16	Industrial	833L with Pb-Free bar line indicator	NiPdAu Pb-Free

**Notes:**

1. Contact factory for die availability. Dice are guaranteed at T<sub>A</sub> = 25°C, DC Electricals only.
2. Tape and Reel.
3. Pb-Free package is recommended for new designs.

**PIN DESCRIPTION**

Pin Number	Pin Name	Pin Function
15, 16 1, 2 3, 4 5, 6	Q0, /Q0 Q1, /Q1 Q2, /Q2 Q3, /Q3	LVDS Differential (Outputs): Normally terminated with 100Ω across the pair (Q, /Q). See “LVDS Outputs” section, Figure 2a. Unused outputs should be terminated with a 100Ω resistor across each pair.
8	EN	This single-ended TTL/CMOS-compatible input functions as a synchronous output enable. The synchronous enable ensures that enable/disable will only occur when the outputs are in a logic LOW state. Note that this input is internally connected to a 25kΩ pull-up resistor and will default to logic HIGH state (enabled) if left open.
9, 12	/IN, IN	Differential Inputs: These input pairs are the differential signal inputs to the device. Inputs accept AC- or DC-Coupled differential signs as small as 100mV. Each pin of a pair internally terminates to a VT pin through 50Ω. Note that these inputs will default to an intermediate state if left open. Please refer to the “Input Interface Applications” section for more details.
10	VREF-AC	Reference Voltage: These outputs bias to V <sub>CC</sub> -1.4V. They are used when AC coupling the inputs (IN, /IN). For AC-Coupled applications, connect VREF-AC to VT pin and bypass with 0.01μF low ESR capacitor to V <sub>CC</sub> . See “Input Interface Applications” section for more details. Maximum sink/source current is ±1.5mA. Due to the limited drive capability, each VREF-AC pin is only intended to drive its respective VT pin.
11	VT	Input Termination Center-Tap: Each side of the differential input pair terminates to a VT pin. The VT pins provide a center-tap to a termination network for maximum interface flexibility. See “Input Interface Applications” section for more details.
13	GND	Ground. GND pins and exposed pad must be connected to the most negative potential of the device ground.
7, 14	VCC	Positive Power Supply: Bypass with 0.1μF//0.01μF low ESR capacitors and place as close to each VCC pin as possible.

**TRUTH TABLE**

IN	/IN	EN	Q	/Q
0	1	1	0	1
1	0	1	1	0
X	X	0	0 <sup>(1)</sup>	1 <sup>(1)</sup>

**Note 1.** On next negative transition of the input signal (IN).

### Absolute Maximum Ratings<sup>(1)</sup>

Supply Voltage ( $V_{CC}$ )	-0.5V to +4.0V
Input Voltage ( $V_{IN}$ )	-0.5V to $V_{CC} + 0.3V$
LVDS Output Current ( $I_{OUT}$ )	±10mA
Input Current	
Source or Sink Current on (IN, /IN)	±50mA
$V_{REF-AC}$ Current	
Source or Sink Current on ( $I_{VT}$ )	±2mA
Maximum Operating Junction Temperature	125°C
Lead Temperature (Soldering, 20 sec.)	260°C
Storage Temperature ( $T_S$ )	-65°C to +150°C

### Operating Ratings<sup>(2)</sup>

Supply Voltage Range	+3.0V to +3.60V
Ambient Temperature ( $T_A$ )	-40°C to +85°C
Package Thermal Resistance <sup>(3)</sup>	
MLF® ( $\theta_{JA}$ )	
Still-Air	60°C/W
MLF® ( $\psi_{JB}$ )	33°C/W

## DC ELECTRICAL CHARACTERISTICS<sup>(4)</sup>

$T_A = -40^\circ\text{C}$  to  $+85^\circ\text{C}$ , unless otherwise stated.

Symbol	Parameter	Condition	Min	Typ	Max	Units
$V_{CC}$	Power Supply Voltage Range		3.0	3.3	3.6	V
$I_{CC}$	Power Supply Current	No load, max. $V_{CC}$ .		75	100	mA
$R_{IN}$	Input Resistance (IN-to-VT)		45	50	55	$\Omega$
$R_{DIFF-IN}$	Differential Input Resistance (IN-to-/IN)		90	100	110	$\Omega$
$V_{IH}$	Input HIGH Voltage (IN, /IN)		0.1		$V_{CC} + 0.3$	V
$V_{IL}$	Input LOW Voltage (IN, /IN)		-0.3		$V_{IH} - 0.1$	V
$V_{IN}$	Input Voltage Swing (IN, /IN)	<b>Note 3</b> , see Figure 2c.	0.1		$V_{CC}$	V
$V_{DIFF\_IN}$	Differential Input Voltage	<b>Note 3</b> , see Figure 2d.	0.2			V
$ I_{IN} $	Input Current IN, /IN				45	mA
$V_{REF-AC}$	Reference Voltage	<b>Note 5</b>	$V_{CC} - 1.525$	$V_{CC} - 1.425$	$V_{CC} - 1.325$	V

**Notes:**

1. Permanent device damage may occur if absolute maximum ratings are exceeded. This is a stress rating only and functional operation is not implied at conditions other than those detailed in the operational sections of this data sheet. Exposure to absolute maximum rating conditions for extended periods may affect device reliability.
2. The data sheet limits are not guaranteed if the device is operated beyond the operating ratings.
3. Package thermal resistance assumes exposed pad is soldered (or equivalent) to the device's most negative potential on the PCB.  $\psi_{JB}$  and  $\theta_{JA}$  values are determined for a 4-layer board in still-air number, unless otherwise stated.
4. The circuit is designed to meet the DC specifications shown in the above table after thermal equilibrium has been established.
5. Due to the internal termination (see "Input Buffer Structure" section) the input current depends on the applied voltages at IN, /IN and VT inputs. Do not apply a combination of voltages that causes the input current to exceed the maximum limit!

**LVDS OUTPUTS DC ELECTRICAL CHARACTERISTICS<sup>(6)</sup>**

$V_{CC} = 3.3V \pm 10\%$ ,  $R_L = 100\Omega$  across the outputs;  $T_A = -40^\circ\text{C}$  to  $+85^\circ\text{C}$

Symbol	Parameter	Condition	Min	Typ	Max	Units
$V_{OUT}$	Output Voltage Swing	See Figure 2c.	250	325		mV
$V_{DIFF\_OUT}$	Differential Output Voltage Swing	See Figure 2d.	500	650		mV
$V_{OCM}$	Output Common Mode Voltage		1.125		1.275	V
$\Delta V_{OCM}$	Change in Common Mode Voltage		-50		50	mV

**LVTTTL/CMOS DC ELECTRICAL CHARACTERISTICS<sup>(6)</sup>**

$V_{CC} = 3.3V \pm 10\%$ ,  $T_A = -40^\circ\text{C}$  to  $+85^\circ\text{C}$

Symbol	Parameter	Condition	Min	Typ	Max	Units
$V_{IH}$	Input HIGH Voltage		2.0		$V_{CC}$	V
$V_{IL}$	Input LOW Voltage		0		0.8	V
$I_{IH}$	Input HIGH Current		-125		30	$\mu\text{A}$
$I_{IL}$	Input LOW Current				-300	$\mu\text{A}$

**Note:**

6. The circuit is designed to meet the DC specifications shown in the above table after thermal equilibrium has been established.

## AC ELECTRICAL CHARACTERISTICS<sup>(7)</sup>

$V_{CC} = +3.3V \pm 10\%$ ;  $R_L = 100\Omega$  across the outputs;  $T_A = -40^\circ C$  to  $+85^\circ C$  unless otherwise stated.

Symbol	Parameter	Condition	Min	Typ	Max	Units
$f_{MAX}$	Maximum Frequency	$V_{OUT} \geq 200mV$	2.0			GHz
$t_{pd}$	Propagation Delay	IN-to-Q $V_{IN} < 400mV$	400	500	600	ps
		IN-to-Q $V_{IN} \geq 400mV$	330	440	530	ps
$t_{SKEW}$	Within-Device Skew	<b>Note 8</b>		5	20	ps
	Part-to-Part Skew	<b>Note 9</b>			200	ps
$t_S$	Set-Up Time	EN to IN, /IN	300			ps
$t_H$	Hold Time	EN to IN, /IN	500			ps
$t_{JITTER}$	Data Random Jitter (RJ) Deterministic Jitter (DJ)	<b>Note 11</b> <b>Note 12</b>			1 10	ps <sub>RMS</sub> ps <sub>PP</sub>
	Clock Cycle-to-Cycle Jitter Total Jitter (TJ)	<b>Note 13</b> <b>Note 14</b>			1 10	ps <sub>RMS</sub> ps <sub>PP</sub>
$t_r, t_f$	Output Rise/Fall Times (20% to 80%)	At full output swing.	60	110	190	ps

**Notes:**

7. High-frequency AC parameters are guaranteed by design and characterization.
8. Within device skew is measured between two different outputs under identical input transitions.
9. Part-to-part skew is defined for two parts with identical power supply voltages at the same temperature and no skew at the edges at the respective inputs.
10. Set-up and hold times apply to synchronous applications that intend to enable/disable before the next clock cycle. For asynchronous applications, set-up and hold times do not apply.
11. Random jitter is measured with a K28.7 pattern, measured at  $\leq f_{MAX}$ .
12. Deterministic jitter is measured at 2.5Gbps with both K28.5 and  $2^{23}-1$  PRBS pattern.
13. Cycle-to-cycle jitter definition: The variation period between adjacent cycles over a random sample of adjacent cycle pairs.  $t_{JITTER\_CC} = T_n - T_{n+1}$ , where T is the time between rising edges of the output signal.
14. Total jitter definition: with an ideal clock input frequency of  $\leq f_{MAX}$  (device), no more than one output edge in  $10^{12}$  output edges will deviate by more than the specified peak-to-peak jitter value.

## TIMING DIAGRAM

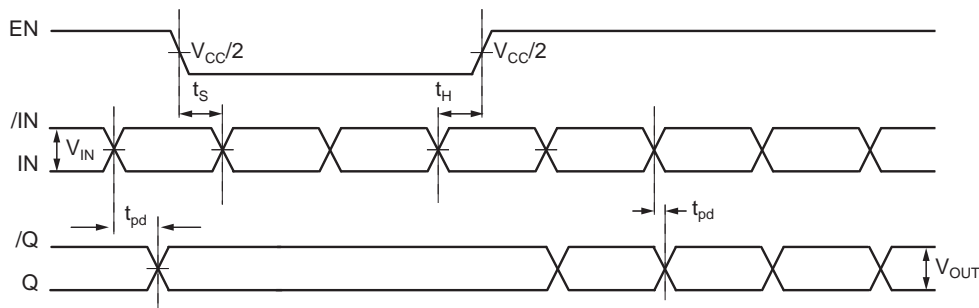

**TYPICAL OPERATING CHARACTERISTICS**

$V_{CC} = 3.3V$ ,  $GND = 0V$ ,  $V_{IN} = 400mV$ ,  $R_L = 100\Omega$  across the outputs,  $T_A = 25^\circ C$ , unless otherwise stated.

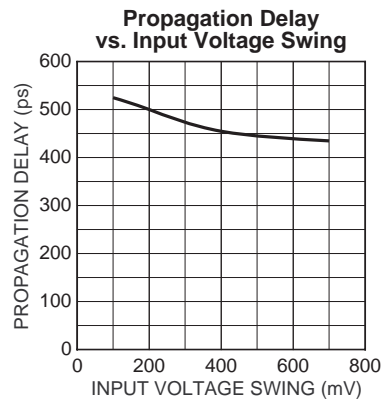
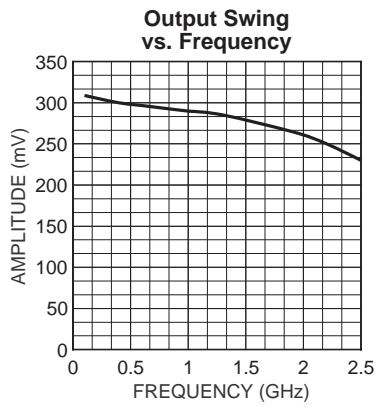

**FUNCTIONAL CHARACTERISTICS**

$V_{CC} = 3.3V$ ,  $GND = 0V$ ,  $V_{IN} = 400mV$ ,  $R_L = 100\Omega$  across the outputs;  $T_A = 25^\circ C$ , unless otherwise stated.

**155MHz Output**

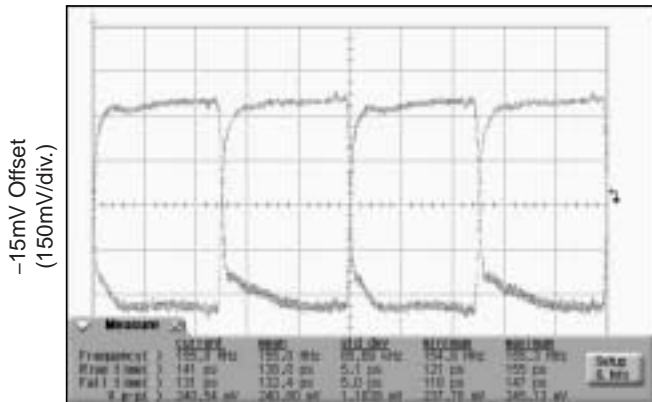

TIME (1.29ns/div.)

**622MHz Output**

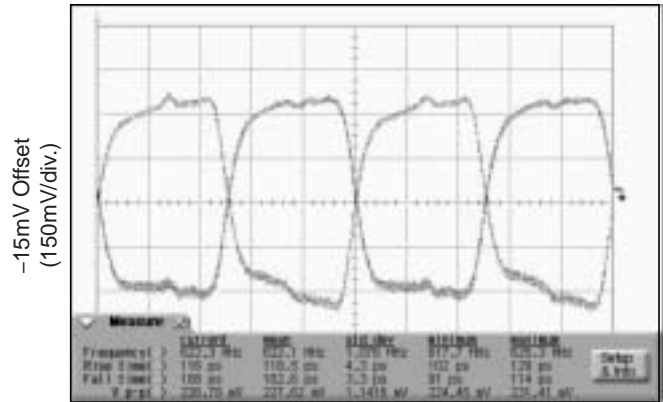

TIME (321.9ps/div.)

**1GHz Output**

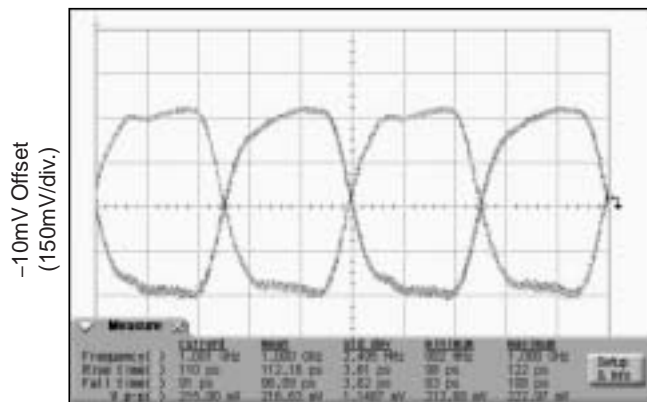

TIME (200ps/div.)

**INPUT STAGE**

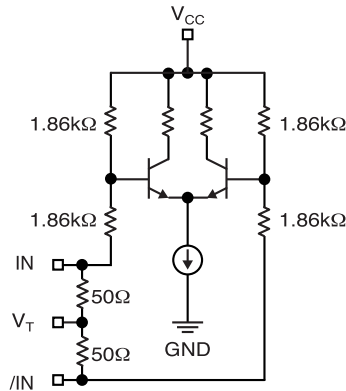

Figure 1. Simplified Differential Input Buffer

**LVDS OUTPUTS**

LVDS specifies a small swing of 325mV typical, on a nominal 1.20V common mode above ground. The common mode voltage has tight limits to permit large variations in ground noise between an LVDS driver and receiver.

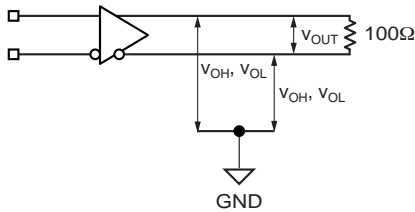

Figure 2a. LVDS Differential Measurement

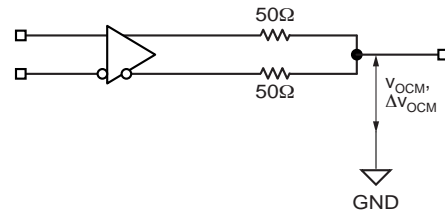

Figure 2b. LVDS Common Mode Measurement

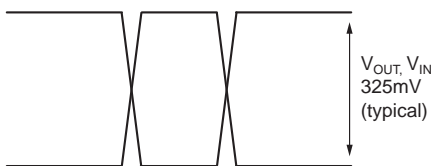

Figure 2c. Single-Ended Swing

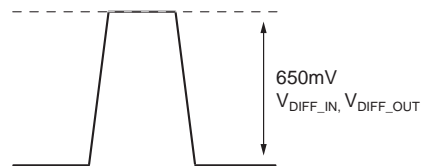
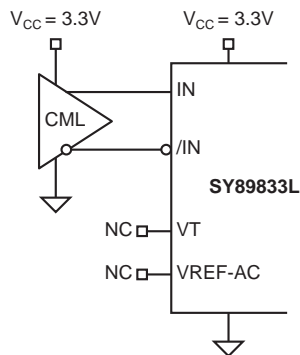

Figure 2d. Differential Swing



**INPUT INTERFACE APPLICATIONS**



**Figure 3a. DC-Coupled CML Input Interface**

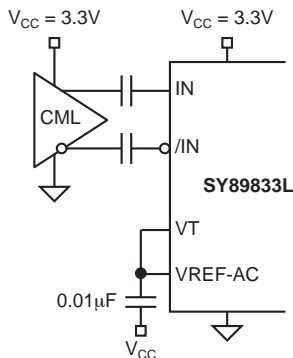

**Figure 3b. AC-Coupled CML Input Interface**

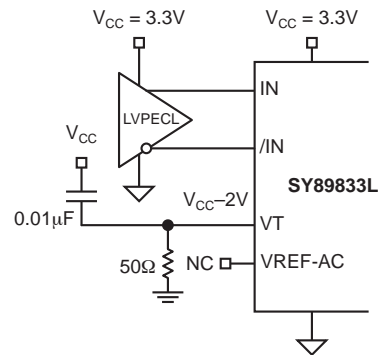

**Figure 3c. DC-Coupled LVPECL Input Interface**

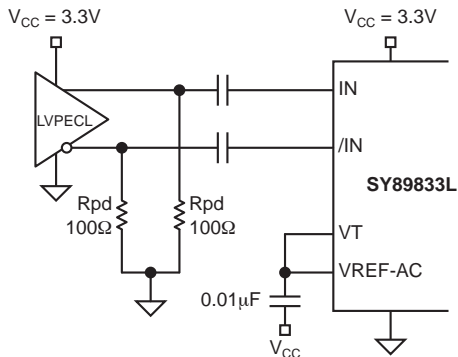

**Figure 3d. AC-Coupled LVPECL Input Interface**

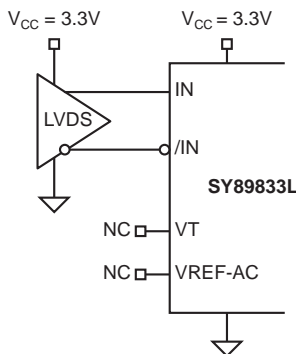
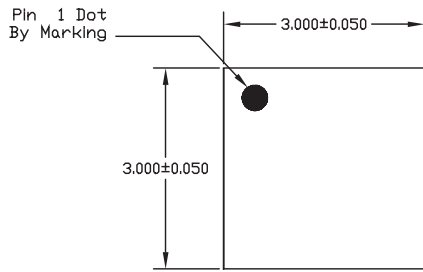

**Figure 3e. LVDS Input Interface**

**RELATED PRODUCT AND SUPPORT DOCUMENTS**

Part Number	Function	Data Sheet Link
SY89830U	2.5V/3.3V/5V 2.5GHz 1:4 PECL/ECL Clock Driver with 2:1 Differential Input MUX	<a href="http://www.micrel.com/product-info/products/sy89830u.shtml">http://www.micrel.com/product-info/products/sy89830u.shtml</a>
SY89831U	Ultra-Precision 1:4 LVPECL Fanout Buffer/Translator with Internal Termination	<a href="http://www.micrel.com/product-info/products/sy89831u.shtml">http://www.micrel.com/product-info/products/sy89831u.shtml</a>
SY89832U	2.5V Ultra-Precision 1:4 LVDS Fanout Buffer/Translator with Internal Termination	<a href="http://www.micrel.com/product-info/products/sy89832u.shtml">http://www.micrel.com/product-info/products/sy89832u.shtml</a>
SY89834U	2.5/3.3V Two Input, 1GHz LVTTTL/CMOS-to-LVPECL 1:4 Fanout Buffer/Translator	<a href="http://www.micrel.com/product-info/products/sy89834u.shtml">http://www.micrel.com/product-info/products/sy89834u.shtml</a>
	16-MLF® Manufacturing Guidelines Exposed Pad Application Note	<a href="http://www.amkor.com/products/notes_papers/MLF_appnote_0301.pdf">http://www.amkor.com/products/notes_papers/MLF_appnote_0301.pdf</a>
HBW Solutions	New Products and Termination App. Note	<a href="http://www.micrel.com/product-info/as/solutions.shtml">http://www.micrel.com/product-info/as/solutions.shtml</a>

**16-PIN EPAD *MicroLeadFrame*® (MLF-16)**



TOP VIEW

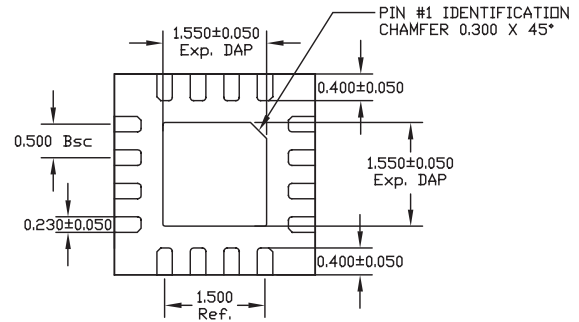

BOTTOM VIEW

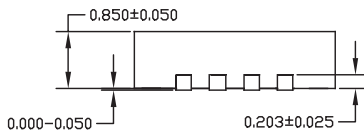

SIDE VIEW

NOTE:

1. ALL DIMENSIONS ARE IN MILLIMETERS.
2. MAX. PACKAGE WARPAGE IS 0.05 mm.
3. MAXIMUM ALLOWABLE BURRS IS 0.076 mm IN ALL DIRECTIONS.
4. PIN #1 ID ON TOP WILL BE LASER/INK MARKED.

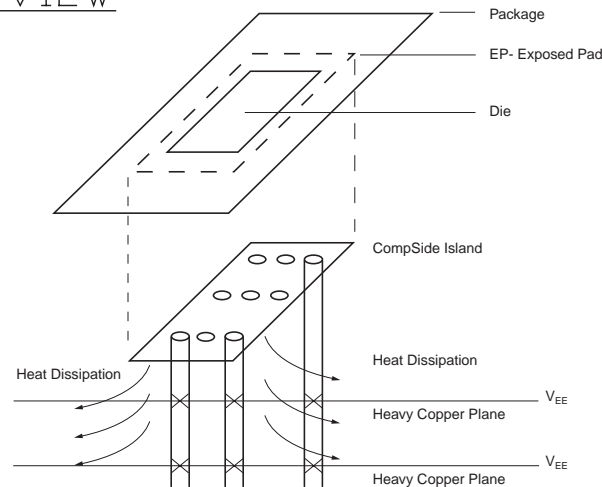

**PCB Thermal Consideration for 16-Pin MLF® Package  
(Always solder, or equivalent, the exposed pad to the PCB)**

**Package Notes:**

1. Package meets Level 2 moisture sensitivity classification, and are shipped in dry-pack form.
2. Exposed pads must be soldered to a ground for proper thermal management.

**MICREL, INC. 2180 FORTUNE DRIVE SAN JOSE, CA 95131 USA**

TEL + 1 (408) 944-0800 FAX + 1 (408) 474-1000 WEB <http://www.micrel.com>

The information furnished by Micrel in this datasheet is believed to be accurate and reliable. However, no responsibility is assumed by Micrel for its use. Micrel reserves the right to change circuitry and specifications at any time without notification to the customer.

Micrel Products are not designed or authorized for use as components in life support appliances, devices or systems where malfunction of a product can reasonably be expected to result in personal injury. Life support devices or systems are devices or systems that (a) are intended for surgical implant into the body or (b) support or sustain life, and whose failure to perform can be reasonably expected to result in a significant injury to the user. A Purchaser's use or sale of Micrel Products for use in life support appliances, devices or systems is at Purchaser's own risk and Purchaser agrees to fully indemnify Micrel for any damages resulting from such use or sale.

© 2005 Micrel, Incorporated.



## Стандарт Электрон Связь

Мы молодая и активно развивающаяся компания в области поставок электронных компонентов. Мы поставляем электронные компоненты отечественного и импортного производства напрямую от производителей и с крупнейших складов мира.

Благодаря сотрудничеству с мировыми поставщиками мы осуществляем комплексные и плановые поставки широчайшего спектра электронных компонентов.

Собственная эффективная логистика и склад в обеспечивает надежную поставку продукции в точно указанные сроки по всей России.

Мы осуществляем техническую поддержку нашим клиентам и предпродажную проверку качества продукции. На все поставляемые продукты мы предоставляем гарантию .

Осуществляем поставки продукции под контролем ВП МО РФ на предприятия военно-промышленного комплекса России , а также работаем в рамках 275 ФЗ с открытием отдельных счетов в уполномоченном банке. Система менеджмента качества компании соответствует требованиям ГОСТ ISO 9001.

Минимальные сроки поставки, гибкие цены, неограниченный ассортимент и индивидуальный подход к клиентам являются основой для выстраивания долгосрочного и эффективного сотрудничества с предприятиями радиоэлектронной промышленности, предприятиями ВПК и научно-исследовательскими институтами России.

С нами вы становитесь еще успешнее!

### Наши контакты:

**Телефон:** +7 812 627 14 35

**Электронная почта:** [sales@st-electron.ru](mailto:sales@st-electron.ru)

**Адрес:** 198099, Санкт-Петербург,  
Промышленная ул, дом № 19, литера Н,  
помещение 100-Н Офис 331