

**Devices Connected/Referenced**

<a href="#">ADuM4160</a>	Full/Low Speed USB Digital Isolator
<a href="#">ADP3338</a>	High Accuracy, 1 A, Low Dropout Regulator (5 V Output Option)

## Universal Serial Bus (USB) Peripheral Isolator Circuit

### EVALUATION AND DESIGN SUPPORT

#### Circuit Evaluation Boards

[CN-0160 Circuit Evaluation Board](#)

#### Design and Integration Files

[Schematics, Layout Files, Bill of Materials](#)

### CIRCUIT FUNCTION AND BENEFITS

The universal serial bus (USB) is rapidly becoming the standard interface for most PC peripherals. It is displacing RS-232 and the parallel printer port because of superior speed, flexibility, and support of device hot swap. There has been a strong desire on the part of industrial and medical equipment manufacturers to use this bus as well, but adoption has been slow because there has not been a good way to provide the isolation required for connections to machines that control dangerous voltages or low leakage defibrillation proof connections in medical applications.

The [ADuM4160](#) provides an inexpensive and easy to implement isolation buffer for medical and industrial peripherals. The challenges that need to be met are

1. Isolate directly in the USB D+ and D– lines allowing the use of existing USB infrastructure in microprocessors.
2. Implement an automatic scheme for data flow of control that does not require external control lines.
3. Provide medical grade isolation.
4. Allow a complete peripheral to meet the USB-IF certification standards.
5. Support full speed (12 Mbps) and low speed (1.5 Mbps) signaling rates.
6. Support flexible power configurations.

The circuit shown in Figure 1 isolates a peripheral device that already supports a USB interface. Because the peripheral is not explicitly defined in this circuit, power to run the secondary side of the isolator has been provided as part of the solution. If the circuit is built onto the PCB of a peripheral

design, power could be sourced from the peripheral's off line supply, a battery, or the USB cable bus power, depending on the needs of the application.

The application circuit shown is typical of many medical and industrial applications.

### CIRCUIT DESCRIPTION

Power for the upstream USB connector is derived from the 5 V VBUS voltage available on the USB cable. The peripheral device must provide all of the signals and pull-up or pull-down resistors that would be required if the [ADuM4160](#) were not present. The downstream side power is provided by a wall wart and an [ADP3338](#) LDO regulator (5 V option). This LDO provides very low dropout voltage, thereby reducing the regulation requirements on the wall wart. Its small size (SOT-223) and 1 A current capability are ideal for this general-purpose circuit where the peripheral device may require cable power to operate.

The [ADuM4160](#) has several options for power, speed, and protection that must be determined. The first is the speed at which the peripheral runs. Peripheral devices run at one of three speeds: low (1.5 Mbps), full (12 Mbps), and high speed (480 Mbps). The [ADuM4160](#) does not support high speed operation and blocks handshaking signals that are used to negotiate that speed. High speed mode starts as a full speed configuration, and the peripheral requests high speed support through a process called a high speed chirp. The [ADuM4160](#) ignores the high speed chirp; therefore, the request for high speed operation is never passed on to the host, and the peripheral continues to work at full speed. The speed of the peripheral on the USB bus is either low speed or full speed. The particular peripheral determines the speed required, and the [ADuM4160](#) must be set to match this speed via the state of the SPU and SPD pins. In the current schematic, the SPU and SPD pins are tied to the internally regulated 3.3 V power supplies, VDD1 and VDD2, setting the part for full speed operation.

#### Rev. A

Circuits from the Lab™ circuits from Analog Devices have been designed and built by Analog Devices engineers. Standard engineering practices have been employed in the design and construction of each circuit, and their function and performance have been tested and verified in a lab environment at room temperature. However, you are solely responsible for testing the circuit and determining its suitability and applicability for your use and application. Accordingly, in no event shall Analog Devices be liable for direct, indirect, special, incidental, consequential or punitive damages due to any cause whatsoever connected to the use of any Circuits from the Lab circuits. (Continued on last page)

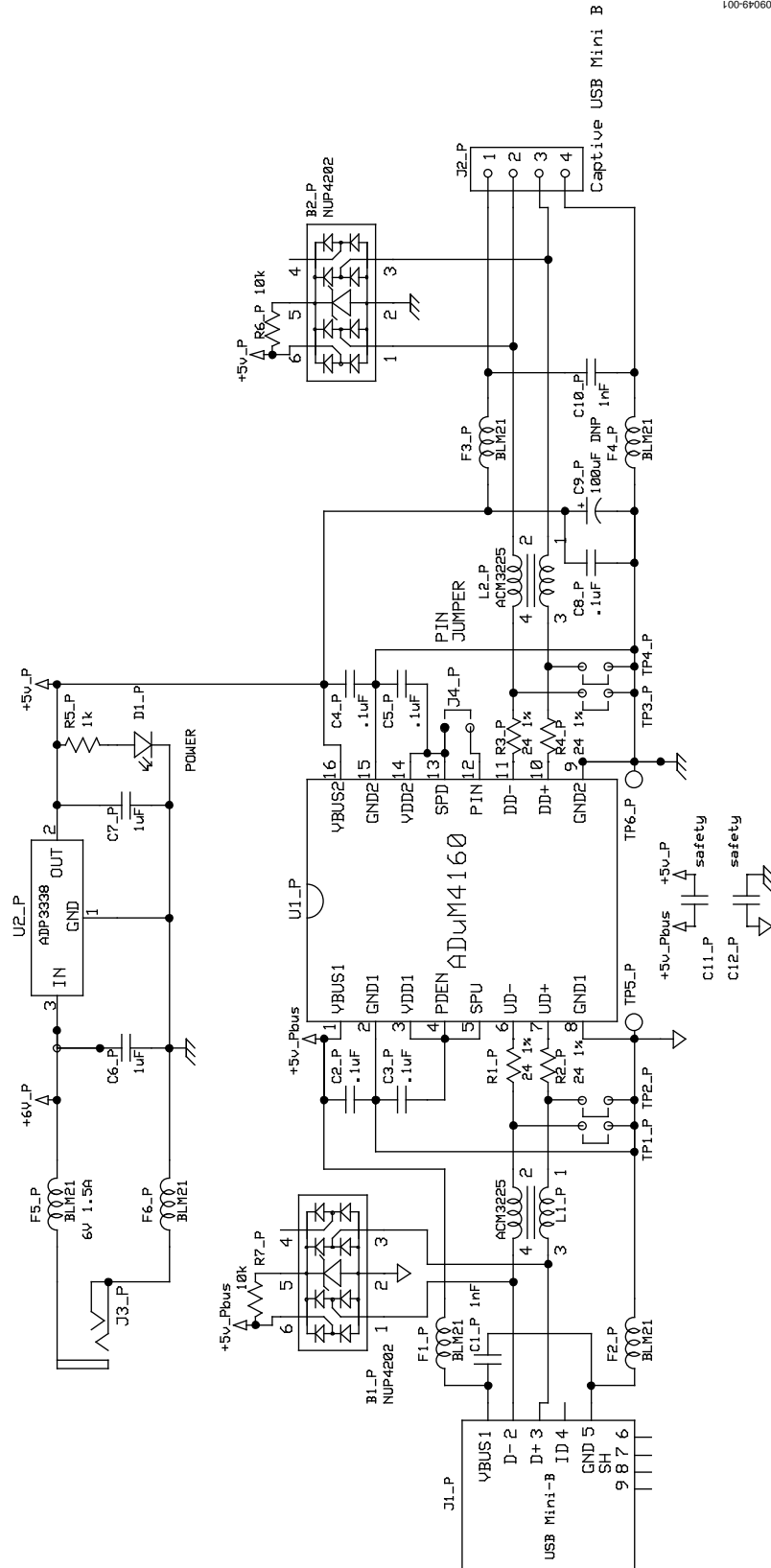

100-61060

Figure 1. USB Peripheral Isolator Circuit

Power can be provided as 5 V through the VBUSx pins, and the 3.3 V signaling voltage is created by an internal 3.3 V regulator at the VDDx pin. Alternatively, the 3.3 V power can also be provided to VBUSx and VDDx, and the part uses the external supply directly, disabling the internal regulator.

This option was provided to allow the ADuM4160 to run either from a 5 V USB cable or from an available 5 V or 3.3 V rail supplied by a peripheral. In the circuit shown, it was connected to accept 5 V from each side, and the internal regulators are active.

The ADuM4160 has an option to delay application of the upstream pull-up under control of the peripheral. This function is controlled by the PIN input. In this application, the PIN input is jumpered high so that the upstream pull-up is applied as soon as peripheral power is applied. In other applications, it can be connected to a GPIO pin of a controller, a fixed delay circuit can be applied, or it can be connected as shown in this circuit. It is the designer's choice how to use this functionality.

Protection devices are included in this circuit. These were chosen from manufacturers that have a wide variety of components available, and the particular components were chosen to allow them to be replaced by 0  $\Omega$  shorts, thereby removing them from the circuit. The choice of protection should be reviewed by the designer and can range from no external protection to a full complement of transient suppressors and filter elements. The circuit elements included in this circuit show a typical high protection configuration.

When the circuit is functioning, packets are detected and data is shuttled from one side of the isolation barrier to the other. Data shown in Figure 2 and Figure 3 demonstrates a typical full speed transaction both as time domain data and as an eye diagram. Features to note in the real-time data are the passive idle state at the start of the packet, which transitions to a driven J, and then the end of the packet at the end of the transaction showing as a single-ended zero state followed by idle J. It is the automatic flow of control and the handling of these special logic states that make the ADuM4160 unique in the marketplace.

The data shown in Figure 2 and Figure 3 below are generated as part of the USB-IF qualification process. Figure 2 shows a test data packet from the ADuM4160 upstream port to the host. Portions to note are the leading idle state where the passive resistor network holds an idle J state. The center portion of the packet is a mix of J and K states. The right side of the packet is an EOP (end of packet) marker, which is a single-ended 0 followed by a driven J, which transitions to an idle J.

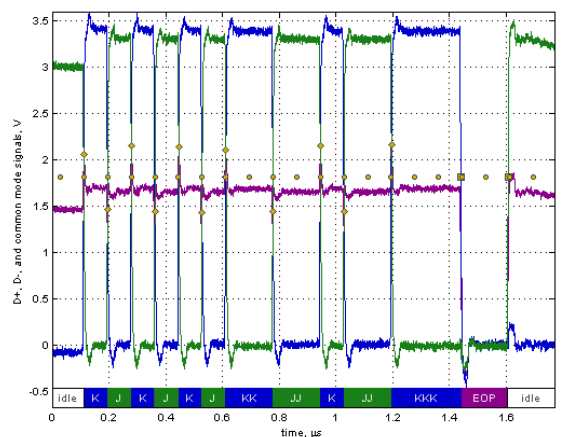

Figure 2. Full Speed Test Packet Traffic Driven By the Upstream ADuM4160 Port

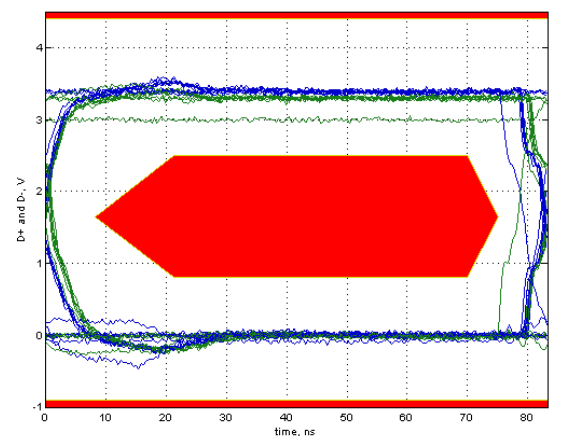

Figure 3. Full Speed Eye Diagram Showing Exclusion Zone

The following are applicable test references:

- Upstream full speed signal quality test reference—USB 2.0 Specification, Section 7.1.11., Section 7.1.2.1.
- Upstream full speed rise time test reference—USB 2.0 Specification, Section 7.1.11., Section 7.1.2.2.
- Upstream full speed fall time test reference—USB 2.0 Specification, Section 7.1.11., Section 7.1.2.2.

Figure 3 is a full speed eye diagram showing that the ADuM4160 provides an adequate open eye, staying well out of the keep out region. Similar data is also taken for low speed evaluation.

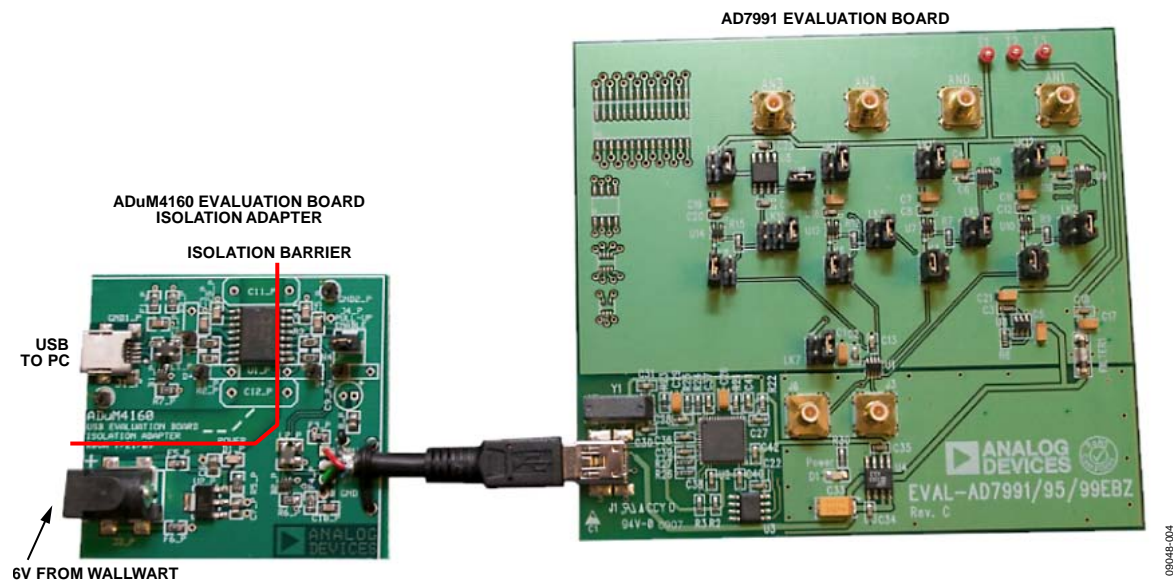

Figure 4. Photo of ADuM4160 USB Evaluation Board Connected to USB Port of AD7991 Evaluation Board

A photo of a typical application circuit is shown in Figure 4. The ADuM4160 evaluation board (left side of photo) is connected to the evaluation board for the AD7991 4-channel, 12-/10-/8-bit ADC with I<sup>2</sup>C compatible interface. The ADC evaluation board acts as a peripheral, which interfaces to a PC (for test and evaluation of the ADC) via the USB port. This provides total isolation between the ADuM4160 USB port and the ADC evaluation board.

Because of the fast edge speeds associated with this circuit, excellent layout, decoupling, and grounding techniques must be employed in order to pass system EMI/RFI tests. See Tutorial MT-031, Tutorial MT-101, and the AN-0971 Application Note for guidance. A complete design support package for this circuit note can be found at <http://www.analog.com/CN0160-DesignSupport>.

## COMMON VARIATIONS

Other linear regulators can be substituted depending on system requirements. See the ADIsimPower™ design tool for details.

## CIRCUIT EVALUATION AND TEST

The ADuM4160 evaluation board isolation adapter described in this note is used for evaluation and testing. A detailed schematic and a picture of the circuit boards used in the test setup are shown in Figure 1 and Figure 4.

## Equipment Needed

The following equipment is needed: a PC with Windows® XP or Vista, a USB data port connection, the ADuM4160 evaluation board isolation adapter, the EVAL-7991EBZ evaluation board and AD7991 evaluation software, two USB cables, and a high speed digital oscilloscope.

## Getting Started

In addition to the circuit and schematic of the test setup described in this Circuit Note, details regarding the ADuM4160 evaluation board isolation adapter, including schematics, Gerber's, and bill of materials, are available at <http://www.analog.com/CN0160-DesignSupport>.

## Functional Block Diagram

See Figure 1 for the schematic diagram and other information regarding the described test setup.

**LEARN MORE**

CN0160 Design Support Package:  
<http://www.analog.com/CN0160-DesignSupport>

ADIsimPower™ Design Tool, Analog Devices.

Cantrell, Mark. Application Note AN-0971, *Recommendations for Control of Radiated Emissions with isoPower Devices*. Analog Devices.

Chen, Baoxing, John Wynne, and Ronn Kliger. *High Speed Digital Isolators Using Microscale On-Chip Transformers*, Analog Devices, 2003.

Chen, Baoxing. *iCoupler® Products with isoPower™ Technology: Signal and Power Transfer Across Isolation Barrier Using Microtransformers*, Analog Devices, 2006

Chen, Baoxing. "Microtransformer Isolation Benefits Digital Control." *Power Electronics Technology*. October 2008.

Krakauer, David. "Digital Isolation Offers Compact, Low-Cost Solutions to Challenging Design Problems." *Analog Dialogue*. Volume 40, December 2006.

MT-031 Tutorial, *Grounding Data Converters and Solving the Mystery of "AGND" and "DGND,"* Analog Devices.

MT-101 Tutorial, *Decoupling Techniques*, Analog Devices.

USB 2.0 Specifications, USB Implementers Forum, Inc.

Wayne, Scott. "iCoupler® Digital Isolators Protect RS-232, RS-485, and CAN Buses in Industrial, Instrumentation, and Computer Applications." *Analog Dialogue*. Volume 39, October 2005.

**Data Sheets and Evaluation Boards**

[ADuM4160 Data Sheet](#)

[ADP3338 Data Sheet](#)

[ADuM4160 Evaluation Board](#)

[AD7991 Data Sheet](#)

[AD7991 Evaluation Board](#)

[ADuM4160 Evaluation Board Isolation Adapter Layout Files](#)

**REVISION HISTORY****11/10—Rev. 0 to Rev. A**

Added Evaluation and Design Support Section.....	1
Changes to Circuit Description Section and Figure 4.....	4
Added Circuit Evaluation and Test Section.....	4
Changes to Learn More Section .....	5

**7/10—Revision 0: Initial Version**

(Continued from first page) Circuits from the Lab circuits are intended only for use with Analog Devices products and are the intellectual property of Analog Devices or its licensors. While you may use the Circuits from the Lab circuits in the design of your product, no other license is granted by implication or otherwise under any patents or other intellectual property by application or use of the Circuits from the Lab circuits. Information furnished by Analog Devices is believed to be accurate and reliable. However, "Circuits from the Lab" are supplied "as is" and without warranties of any kind, express, implied, or statutory including, but not limited to, any implied warranty of merchantability, noninfringement or fitness for a particular purpose and no responsibility is assumed by Analog Devices for their use, nor for any infringements of patents or other rights of third parties that may result from their use. Analog Devices reserves the right to change any Circuits from the Lab circuits at any time without notice but is under no obligation to do so.

©2010 Analog Devices, Inc. All rights reserved. Trademarks and registered trademarks are the property of their respective owners.  
 CN09049-0-11/10(A)



[www.analog.com](http://www.analog.com)



## Стандарт Электрон Связь

Мы молодая и активно развивающаяся компания в области поставок электронных компонентов. Мы поставляем электронные компоненты отечественного и импортного производства напрямую от производителей и с крупнейших складов мира.

Благодаря сотрудничеству с мировыми поставщиками мы осуществляем комплексные и плановые поставки широчайшего спектра электронных компонентов.

Собственная эффективная логистика и склад в обеспечивает надежную поставку продукции в точно указанные сроки по всей России.

Мы осуществляем техническую поддержку нашим клиентам и предпродажную проверку качества продукции. На все поставляемые продукты мы предоставляем гарантию .

Осуществляем поставки продукции под контролем ВП МО РФ на предприятия военно-промышленного комплекса России , а также работаем в рамках 275 ФЗ с открытием отдельных счетов в уполномоченном банке. Система менеджмента качества компании соответствует требованиям ГОСТ ISO 9001.

Минимальные сроки поставки, гибкие цены, неограниченный ассортимент и индивидуальный подход к клиентам являются основой для выстраивания долгосрочного и эффективного сотрудничества с предприятиями радиоэлектронной промышленности, предприятиями ВПК и научно-исследовательскими институтами России.

С нами вы становитесь еще успешнее!

### Наши контакты:

**Телефон:** +7 812 627 14 35

**Электронная почта:** [sales@st-electron.ru](mailto:sales@st-electron.ru)

**Адрес:** 198099, Санкт-Петербург,  
Промышленная ул, дом № 19, литера Н,  
помещение 100-Н Офис 331