



DATA SHEET

BIPOLAR ANALOG INTEGRATED CIRCUITS

μ PC2709TB

5 V, SUPER MINIMOLD SILICON MMIC MEDIUM OUTPUT POWER AMPLIFIER

DESCRIPTION

The μ PC2709TB is a silicon monolithic integrated circuits designed as 1st IF amplifier for DBS tuners. This IC is packaged in super minimold package which is smaller than conventional minimold.

The μ PC2709TB has compatible pin connections and performance to μ PC2709T of conventional minimold version. So, in the case of reducing your system size, μ PC2709TB is suitable to replace from μ PC2709T.

These IC is manufactured using NEC's 20 GHz f_T NESAT™III silicon bipolar process. This process uses silicon nitride passivation film and gold electrodes. These materials can protect chip surface from external pollution and prevent corrosion/migration. Thus, this IC has excellent performance, uniformity and reliability.

FEATURES

- High-density surface mounting : 6-pin super minimold package (2.0 × 1.25 × 0.9 mm)
- Wideband response : $f_u = 2.3$ GHz TYP. @3 dB bandwidth
- Medium output power : $P_{O(sat)} = +11.5$ dBm@f = 1 GHz with external inductor
- Supply voltage : $V_{CC} = 4.5$ to 5.5 V
- Power gain : $G_P = 23$ dB TYP. @f = 1 GHz
- Port impedance : input/output 50 Ω

APPLICATIONS

- 1st IF amplifiers in DBS converters
- RF stage buffer in DBS tuners, etc.

ORDERING INFORMATION (PB-Free)

| Part Number | Package | Marking | Supplying Form |
|---------------------|----------------------|---------|---|
| μ PC2709TB-E3-A | 6-pin super minimold | C1E | Embossed tape 8 mm wide. 1, 2, 3 pins face the perforation side of the tape. Qty 3 kpcs/reel. |

Remark To order evaluation samples, please contact your local sales office (Part number for sample order: μ PC2709TB-A).

Caution Electro-static sensitive devices

The information in this document is subject to change without notice. Before using this document, please confirm that this is the latest version.

PIN CONNECTIONS

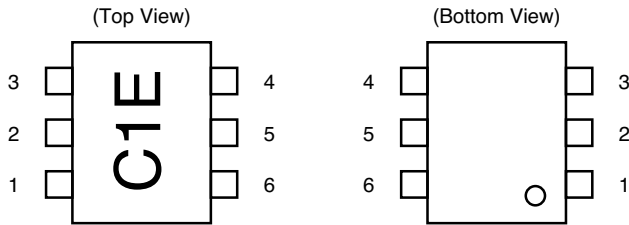

| Pin No. | Pin Name |
|---------|-----------------|
| 1 | INPUT |
| 2 | GND |
| 3 | GND |
| 4 | OUTPUT |
| 5 | GND |
| 6 | V _{CC} |

★ PRODUCT LINE-UP OF 5 V-BIAS SILICON MMIC MEDIUM OUTPUT POWER AMPLIFIER

(T_A = +25°C, V_{CC} = V_{out} = 5.0 V, Z_S = Z_L = 50 Ω)

| Part No. | f _u (GHz) | P _{O (sat)} (dBm) | G _P (dB) | NF (dB) | I _{cc} (mA) | Package | Marking |
|-----------|-------------------------|-------------------------------|------------------------|---------------------|-------------------------|----------------------|---------|
| μPC2708T | 2.9 | +10.0 | 15 | 6.5 @f = 1 GHz | 26 | 6-pin minimold | C1D |
| μPC2708TB | | | | | | 6-pin super minimold | |
| μPC2709T | 2.3 | +11.5 | 23 | 5 @f = 1 GHz | 25 | 6-pin minimold | C1E |
| μPC2709TB | | | | | | 6-pin super minimold | |
| μPC2710T | 1.0 | +13.5 | 33 | 3.5 @f = 0.5 GHz | 22 | 6-pin minimold | C1F |
| μPC2710TB | | | | | | 6-pin super minimold | |
| μPC2776T | 2.7 | +8.5 | 23 | 6.0 @f = 1 GHz | 25 | 6-pin minimold | C2L |
| μPC2776TB | | | | | | 6-pin super minimold | |

Remark Typical performance. Please refer to ELECTRICAL CHARACTERISTICS in detail.

Caution The package size distinguishes between minimold and super minimold.

SYSTEM APPLICATION EXAMPLE

EXAMPLE OF DBS CONVERTERS

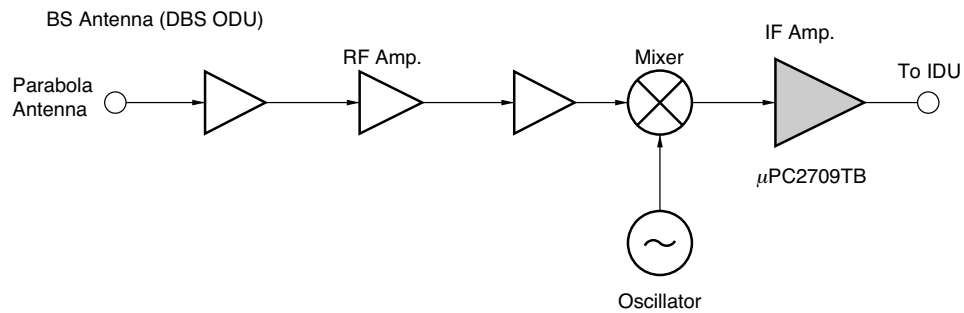

EXAMPLE OF 900 MHz BAND, 1.5 GHz BAND DIGITAL CELLULAR TELEPHONE

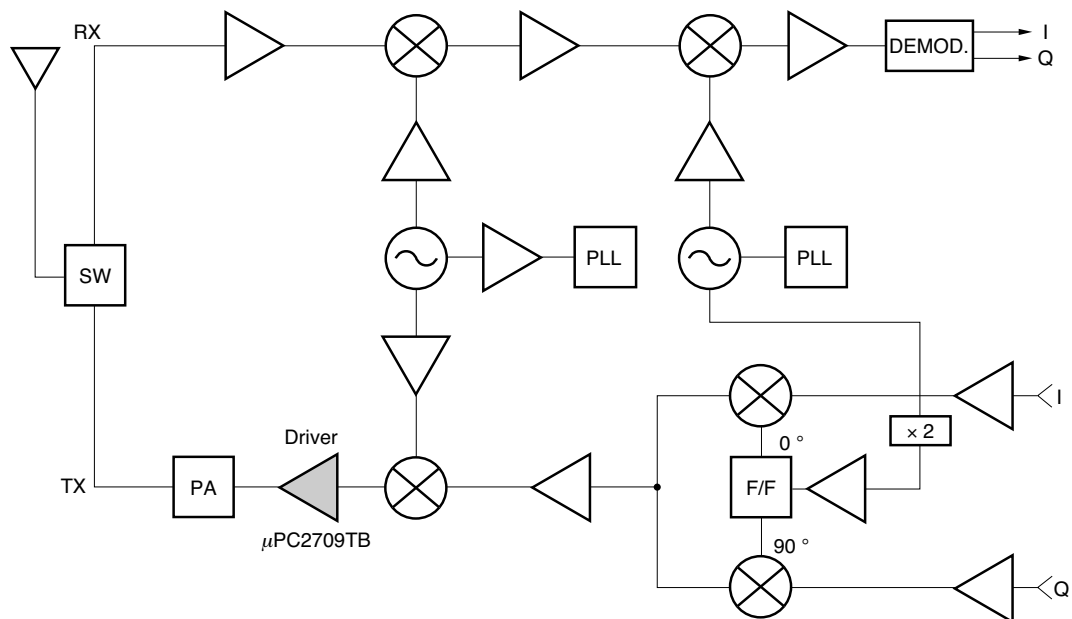

PIN EXPLANATION

| Pin No. | Pin Name | Applied Voltage (V) | Pin Voltage (V) ^{Note} | Function and Applications | Internal Equivalent Circuit |
|-------------|----------|---|---------------------------------|---|-----------------------------|
| 1 | INPUT | - | 1.05 | Signal input pin. A internal matching circuit, configured with resistors, enables 50 Ω connection over a wide band. A multi-feedback circuit is designed to cancel the deviations of h_{FE} and resistance. This pin must be coupled to signal source with capacitor for DC cut. | |
| 4 | OUTPUT | Voltage as same as V_{CC} through external inductor | - | Signal output pin. The inductor must be attached between V_{CC} and output pins to supply current to the internal output transistors. | |
| 6 | V_{CC} | 4.5 to 5.5 | - | Power supply pin, which biases the internal input transistor. This pin should be externally equipped with bypass capacitor to minimize its impedance. | |
| 2 3 5 | GND | 0 | - | Ground pin. This pin should be connected to system ground with minimum inductance. Ground pattern on the board should be formed as wide as possible. All the ground pins must be connected together with wide ground pattern to decrease impedance defference. | |

Note Pin voltage is measured at $V_{CC} = 5.0$ V

ABSOLUTE MAXIMUM RATINGS

| Parameter | Symbol | Conditions | Ratings | Unit |
|-------------------------------|------------------|---|-------------|------|
| Supply Voltage | V _{CC} | T _A = +25°C, Pin 4 and 6 | 6 | V |
| Total Circuit Current | I _{CC} | T _A = +25°C | 60 | mA |
| Power Dissipation | P _D | Mounted on double copper clad 50 × 50 × 1.6 mm epoxy glass PWB (T _A = +85°C) | 270 | mW |
| Operating Ambient Temperature | T _A | | -40 to +85 | °C |
| Storage Temperature | T _{stg} | | -55 to +150 | °C |
| Input Power | P _{in} | T _A = +25°C | +10 | dBm |

★

RECOMMENDED OPERATING RANGE

| Parameter | Symbol | MIN. | TYP. | MAX. | Unit | Remark |
|-------------------------------|-----------------|------|------|------|------|--|
| Supply Voltage | V _{CC} | 4.5 | 5.0 | 5.5 | V | The same voltage should be applied to pin 4 and 6. |
| Operating Ambient Temperature | T _A | -40 | +25 | +85 | °C | |

ELECTRICAL CHARACTERISTICS (T_A = +25°C, V_{CC} = V_{out} = 5.0 V, Z_s = Z_L = 50 Ω)

| Parameter | Symbol | Test Conditions | MIN. | TYP. | MAX. | Unit |
|---------------------------------|----------------------|--|------|-------|------|------|
| Circuit Current | I _{CC} | No input signal | 19 | 25 | 32 | mA |
| Power Gain | G _P | f = 1 GHz | 21.0 | 23.0 | 26.5 | dB |
| Saturated Output Power | P _{O (sat)} | f = 1 GHz, P _{in} = 0 dBm | +9.0 | +11.5 | - | dBm |
| Noise Figure | NF | f = 1 GHz | - | 5.0 | 6.5 | dB |
| Upper Limit Operating Frequency | f _u | 3 dB down below flat gain at f = 0.1 GHz | 2.0 | 2.3 | - | GHz |
| Isolation | ISL | f = 1 GHz | 26 | 31 | - | dB |
| Input Return Loss | RL _{in} | f = 1 GHz | 7 | 10 | - | dB |
| Output Return Loss | RL _{out} | f = 1 GHz | 7 | 10 | - | dB |
| Gain Flatness | ΔG _P | f = 0.1 to 1.8 GHz | - | ±1.0 | - | dB |

TEST CIRCUIT

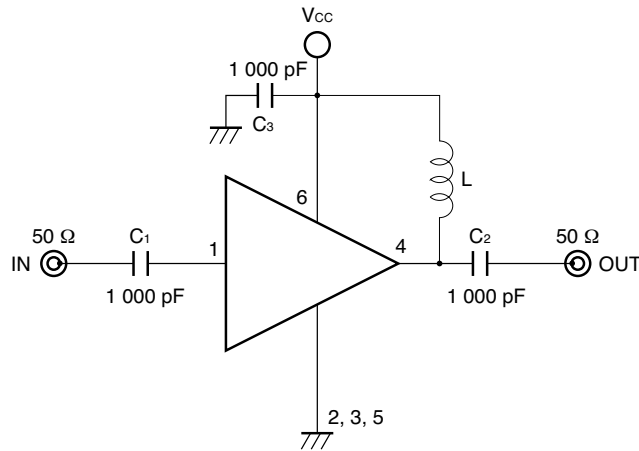

COMPONENTS OF TEST CIRCUIT FOR MEASURING ELECTRICAL CHARACTERISTICS EXAMPLE OF ACTUAL APPLICATION COMPONENTS

| | Type | Value |
|----------------------------------|-----------|----------|
| C ₁ to C ₂ | Bias Tee | 1 000 pF |
| C ₃ | Capacitor | 1 000 pF |
| L | Bias Tee | 1 000 nH |

| | Type | Value | Operating Frequency |
|----------------------------------|----------------|----------|---------------------|
| C ₁ to C ₃ | Chip capacitor | 1 000 pF | 100 MHz or higher |
| L | Chip inductor | 300 nH | 10 MHz or higher |
| | | 100 nH | 100 MHz or higher |
| | | 10 nH | 1.0 GHz or higher |

INDUCTOR FOR THE OUTPUT PIN

The internal output transistor of this IC consumes 20 mA, to output medium power. To supply current for output transistor, connect an inductor between the V_{cc} pin (pin 6) and output pin (pin 4). Select large value inductance, as listed above.

The inductor has both DC and AC effects. In terms of DC, the inductor biases the output transistor with minimum voltage drop to output enable high level. In terms of AC, the inductor make output-port impedance higher to get enough gain. In this case, large inductance and Q is suitable.

CAPACITORS FOR THE V_{cc}, INPUT, AND OUTPUT PINS

Capacitors of 1 000 pF are recommendable as the bypass capacitor for the V_{cc} pin and the coupling capacitors for the input and output pins.

The bypass capacitor connected to the V_{cc} pin is used to minimize ground impedance of V_{cc} pin. So, stable bias can be supplied against V_{cc} fluctuation.

The coupling capacitors, connected to the input and output pins, are used to cut the DC and minimize RF serial impedance. Their capacitance are therefore selected as lower impedance against a 50 Ω load. The capacitors thus perform as high pass filters, suppressing low frequencies to DC.

To obtain a flat gain from 100 MHz upwards, 1 000 pF capacitors are used in the test circuit. In the case of under 10 MHz operation, increase the value of coupling capacitor such as 10 000 pF. Because the coupling capacitors are determined by equation, $C = 1/(2 \pi Rf_c)$.

ILLUSTRATION OF THE TEST CIRCUIT ASSEMBLED ON EVALUATION BOARD

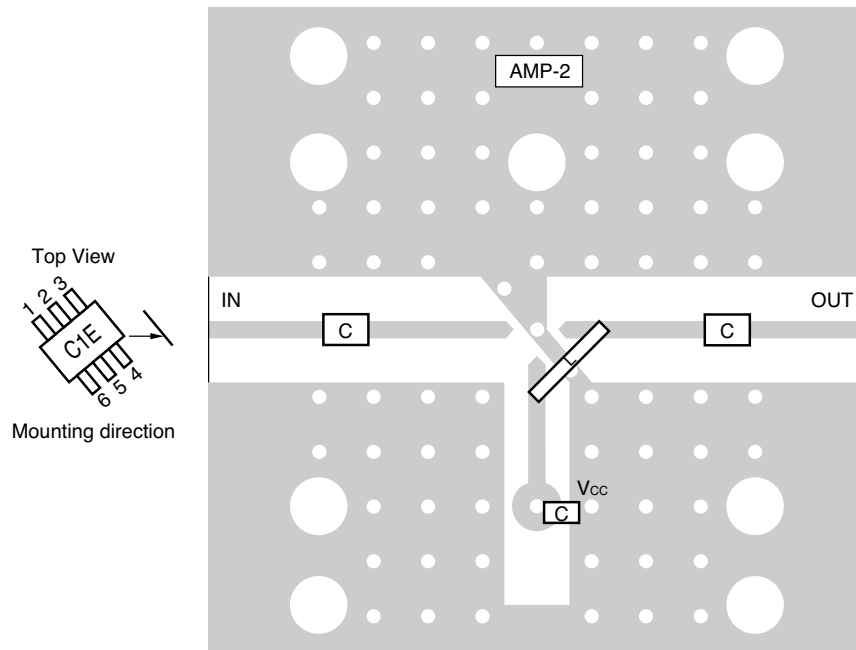

COMPONENT LIST

| | Value |
|---|----------|
| C | 1 000 pF |
| L | 300 nH |

Notes

1. 30 × 30 × 0.4 mm double sided copper clad polyimide board.
2. Back side: GND pattern
3. Solder plated on pattern
4. ○ ○: Through holes

For more information on the use of this IC, refer to the following application note:

USAGE AND APPLICATION OF SILICON MEDIUM-POWER HIGH-FREQUENCY AMPLIFIER MMIC (P12152E).

TYPICAL CHARACTERISTICS (Unless otherwise specified, $T_A = +25^\circ\text{C}$)

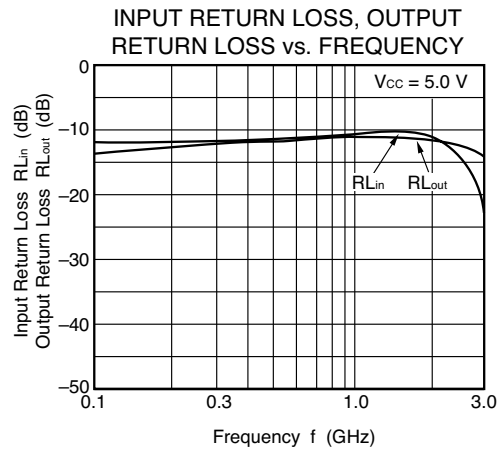
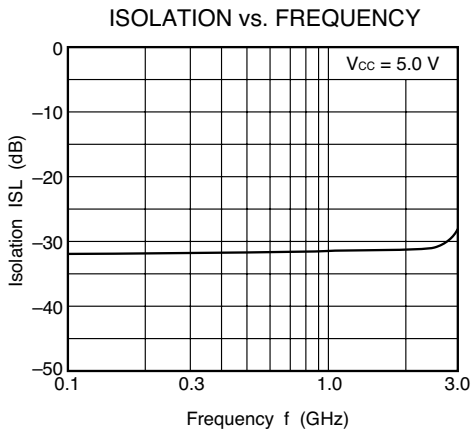
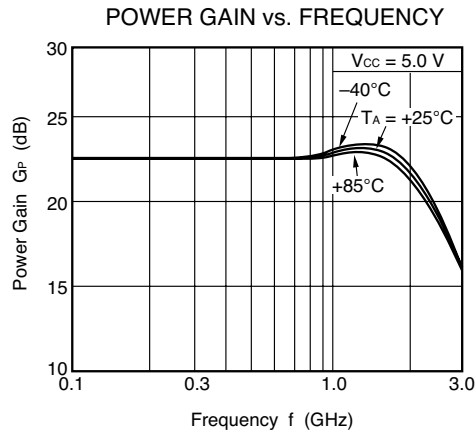
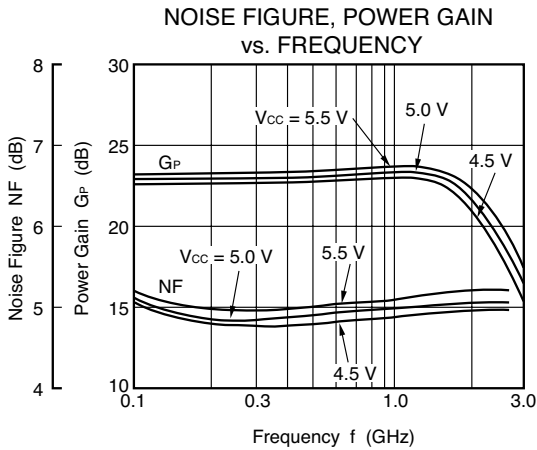
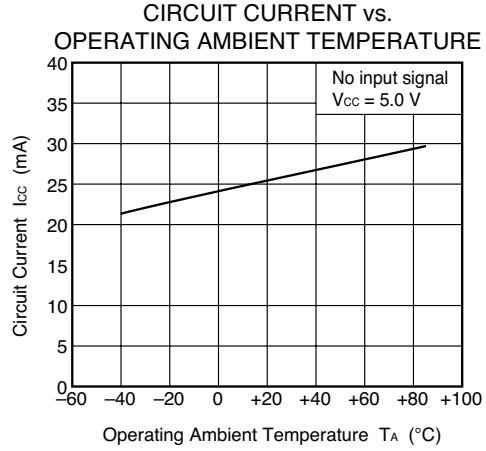
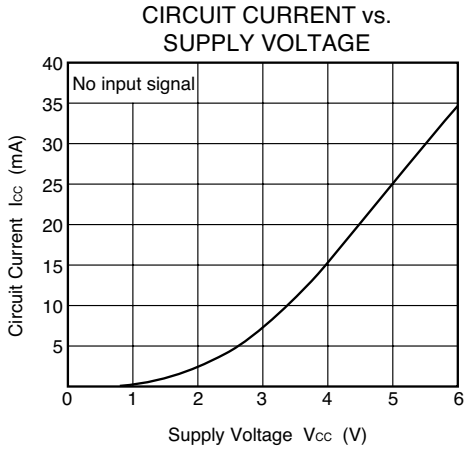

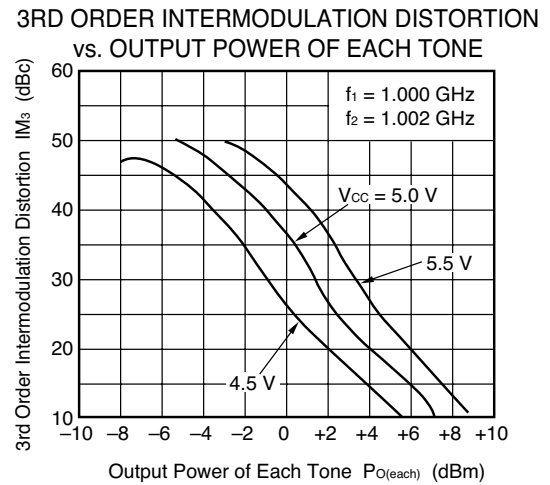
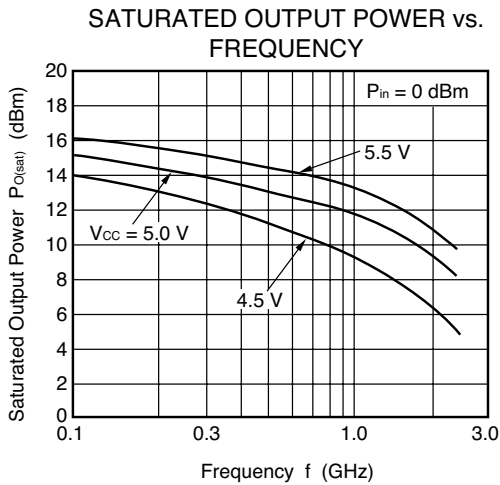
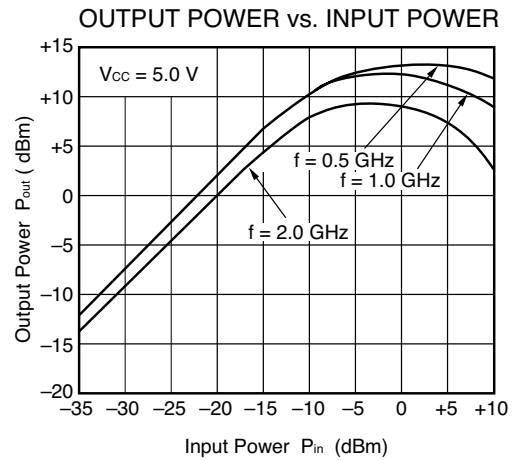
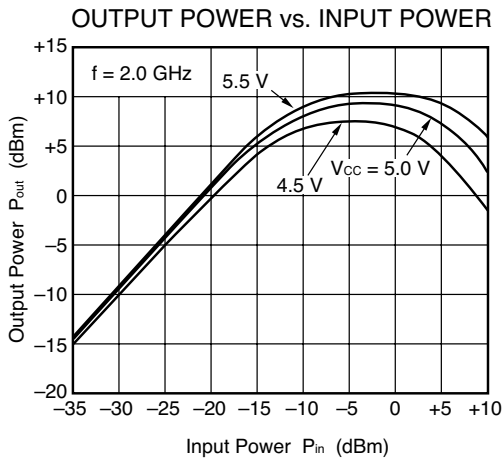
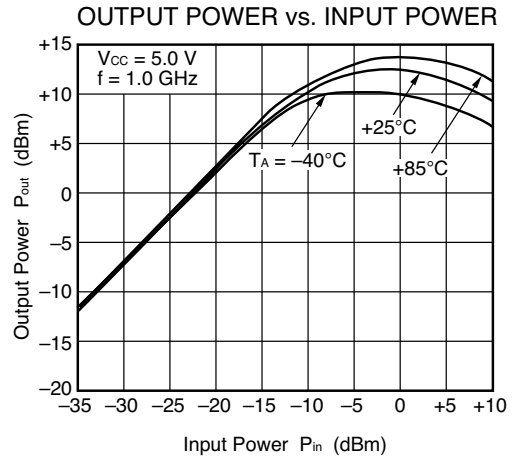
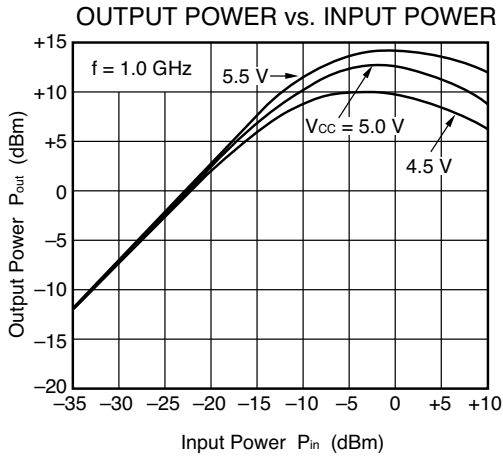

Remark The graphs indicate nominal characteristics.

S-PARAMETERS ($T_A = +25^\circ\text{C}$, $V_{CC} = V_{out} = 5.0\text{ V}$)

S₁₁-FREQUENCY

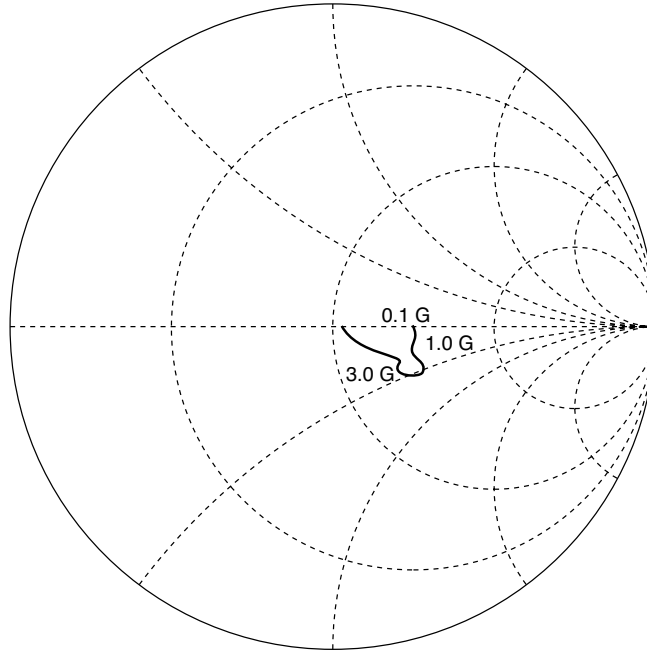

S₂₂-FREQUENCY

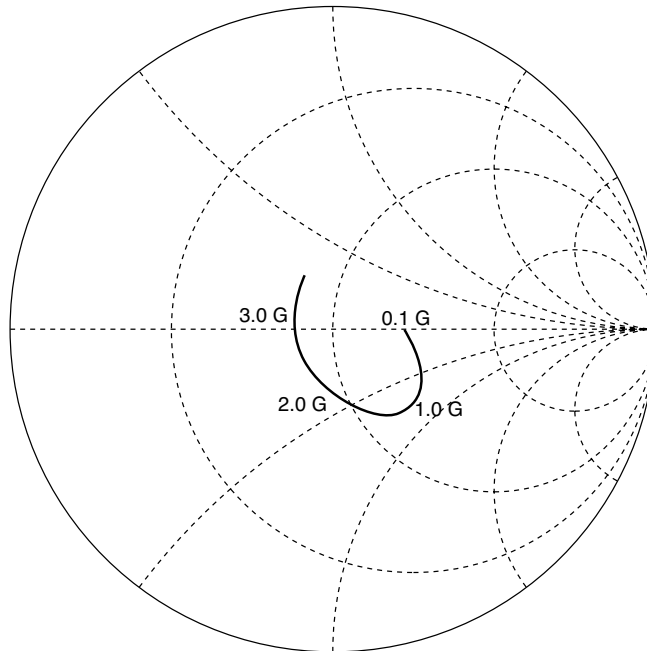

TYPICAL S-PARAMETER VALUES (T_A = +25°C)

V_{CC} = V_{out} = 5.0 V, I_{CC} = 26 mA

| Frequency MHz | S ₁₁ | | S ₂₁ | | S ₁₂ | | S ₂₂ | | K |
|------------------|-----------------|-------|-----------------|--------|-----------------|------|-----------------|--------|------|
| | MAG. | ANG. | MAG. | ANG. | MAG. | ANG. | MAG. | ANG. | |
| 100.0000 | 0.227 | 0.2 | 13.698 | -4.5 | 0.027 | -1.0 | 0.196 | 0.9 | 1.37 |
| 200.0000 | 0.239 | 1.0 | 13.724 | -9.6 | 0.027 | 3.1 | 0.207 | 2.2 | 1.36 |
| 300.0000 | 0.245 | 2.9 | 13.830 | -14.5 | 0.026 | 4.7 | 0.212 | 4.1 | 1.38 |
| 400.0000 | 0.244 | 2.5 | 13.998 | -19.9 | 0.027 | 7.8 | 0.223 | 3.4 | 1.32 |
| 500.0000 | 0.243 | 1.5 | 14.109 | -25.0 | 0.026 | 9.8 | 0.234 | 2.1 | 1.33 |
| 600.0000 | 0.247 | -1.5 | 14.246 | -30.4 | 0.027 | 11.9 | 0.252 | -0.4 | 1.26 |
| 700.0000 | 0.265 | -3.2 | 14.538 | -35.5 | 0.028 | 13.6 | 0.270 | -2.3 | 1.20 |
| 800.0000 | 0.284 | -3.6 | 14.703 | -41.3 | 0.028 | 14.9 | 0.287 | -4.6 | 1.15 |
| 900.0000 | 0.301 | -3.3 | 15.051 | -47.0 | 0.028 | 17.2 | 0.298 | -7.4 | 1.10 |
| 1000.0000 | 0.305 | -2.4 | 15.331 | -53.5 | 0.029 | 18.8 | 0.309 | -11.9 | 1.05 |
| 1100.0000 | 0.299 | -3.2 | 15.605 | -60.0 | 0.029 | 20.9 | 0.322 | -17.1 | 1.04 |
| 1200.0000 | 0.300 | -6.3 | 15.773 | -66.7 | 0.029 | 22.5 | 0.336 | -21.5 | 1.01 |
| 1300.0000 | 0.314 | -10.3 | 16.152 | -74.0 | 0.030 | 23.8 | 0.353 | -24.8 | 0.95 |
| 1400.0000 | 0.328 | -14.4 | 16.282 | -81.0 | 0.030 | 26.1 | 0.353 | -28.8 | 0.93 |
| 1500.0000 | 0.354 | -17.3 | 16.337 | -89.3 | 0.032 | 25.6 | 0.368 | -35.5 | 0.86 |
| 1600.0000 | 0.359 | -19.5 | 16.370 | -96.5 | 0.031 | 26.8 | 0.370 | -41.8 | 0.86 |
| 1700.0000 | 0.373 | -22.1 | 16.256 | -104.5 | 0.033 | 28.0 | 0.382 | -46.9 | 0.81 |
| 1800.0000 | 0.371 | -26.8 | 15.977 | -112.7 | 0.032 | 29.3 | 0.381 | -52.8 | 0.83 |
| 1900.0000 | 0.379 | -31.1 | 15.529 | -120.5 | 0.033 | 31.3 | 0.378 | -57.8 | 0.83 |
| 2000.0000 | 0.386 | -36.0 | 15.307 | -128.1 | 0.034 | 31.0 | 0.373 | -64.1 | 0.82 |
| 2100.0000 | 0.387 | -39.5 | 14.745 | -135.9 | 0.033 | 32.2 | 0.366 | -70.8 | 0.85 |
| 2200.0000 | 0.374 | -43.8 | 14.212 | -143.7 | 0.033 | 30.5 | 0.363 | -78.1 | 0.90 |
| 2300.0000 | 0.360 | -48.7 | 13.633 | -151.3 | 0.033 | 33.9 | 0.353 | -83.0 | 0.94 |
| 2400.0000 | 0.339 | -55.4 | 12.846 | -158.7 | 0.032 | 35.5 | 0.331 | -90.0 | 1.06 |
| 2500.0000 | 0.338 | -62.0 | 11.990 | -165.5 | 0.033 | 38.0 | 0.318 | -95.6 | 1.11 |
| 2600.0000 | 0.334 | -66.0 | 11.265 | -172.1 | 0.033 | 39.1 | 0.304 | -102.5 | 1.20 |
| 2700.0000 | 0.330 | -69.0 | 10.560 | -177.8 | 0.033 | 40.8 | 0.295 | -108.3 | 1.25 |
| 2800.0000 | 0.311 | -69.9 | 9.942 | 176.2 | 0.033 | 43.5 | 0.282 | -113.7 | 1.36 |
| 2900.0000 | 0.291 | -72.5 | 9.432 | 171.3 | 0.035 | 44.9 | 0.267 | -118.6 | 1.40 |
| 3000.0000 | 0.258 | -76.5 | 8.818 | 166.5 | 0.035 | 47.4 | 0.246 | -125.1 | 1.55 |
| 3100.0000 | 0.240 | -80.6 | 8.353 | 161.9 | 0.035 | 53.4 | 0.225 | -131.2 | 1.64 |

★ **PACKAGE DIMENSIONS**

6-PIN SUPER MINIMOLD (UNIT: mm)

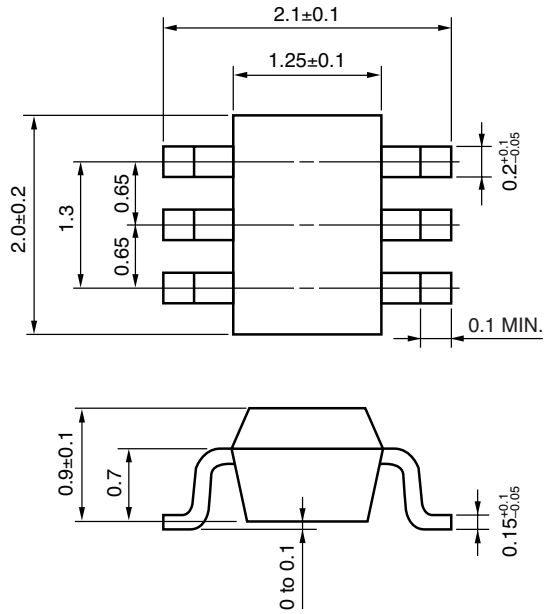

NOTES ON CORRECT USE

- (1) Observe precautions for handling because of electro-static sensitive devices.
- (2) Form a ground pattern as widely as possible to minimize ground impedance (to prevent undesired oscillation).
All the ground pins must be connected together with wide ground pattern to decrease impedance difference.
- (3) The bypass capacitor should be attached to the V_{CC} pin.
- (4) The inductor (L) must be attached between V_{CC} and output pins. The inductance value should be determined in accordance with desired frequency.
- (5) The DC cut capacitor must be attached to input and output pin.

RECOMMENDED SOLDERING CONDITIONS

This product should be soldered under the following recommended conditions. For soldering methods and conditions other than those recommended below, contact your NEC sales representative.

| Soldering Method | Soldering Conditions | Recommended Condition Symbol |
|------------------|---|------------------------------|
| Infrared Reflow | Package peak temperature: 235°C or below Time: 30 seconds or less (at 210°C) Count: 3, Exposure limit: None ^{Note} | IR35-00-3 |
| VPS | Package peak temperature: 215°C or below Time: 40 seconds or less (at 200°C) Count: 3, Exposure limit: None ^{Note} | VP15-00-3 |
| Wave Soldering | Soldering bath temperature: 260°C or below Time: 10 seconds or less Count: 1, Exposure limit: None ^{Note} | WS60-00-1 |
| Partial Heating | Pin temperature: 300°C Time: 3 seconds or less (per side of device) Exposure limit: None ^{Note} | — |

Note After opening the dry pack, keep it in a place below 25°C and 65% RH for the allowable storage period.

Caution Do not use different soldering methods together (except for partial heating).

For details of recommended soldering conditions for surface mounting, refer to information document SEMICONDUCTOR DEVICE MOUNTING TECHNOLOGY MANUAL (C10535E).



Стандарт Электрон Связь

Мы молодая и активно развивающаяся компания в области поставок электронных компонентов. Мы поставляем электронные компоненты отечественного и импортного производства напрямую от производителей и с крупнейших складов мира.

Благодаря сотрудничеству с мировыми поставщиками мы осуществляем комплексные и плановые поставки широчайшего спектра электронных компонентов.

Собственная эффективная логистика и склад в обеспечивает надежную поставку продукции в точно указанные сроки по всей России.

Мы осуществляем техническую поддержку нашим клиентам и предпродажную проверку качества продукции. На все поставляемые продукты мы предоставляем гарантию .

Осуществляем поставки продукции под контролем ВП МО РФ на предприятия военно-промышленного комплекса России , а также работаем в рамках 275 ФЗ с открытием отдельных счетов в уполномоченном банке. Система менеджмента качества компании соответствует требованиям ГОСТ ISO 9001.

Минимальные сроки поставки, гибкие цены, неограниченный ассортимент и индивидуальный подход к клиентам являются основой для выстраивания долгосрочного и эффективного сотрудничества с предприятиями радиоэлектронной промышленности, предприятиями ВПК и научно-исследовательскими институтами России.

С нами вы становитесь еще успешнее!

Наши контакты:

Телефон: +7 812 627 14 35

Электронная почта: sales@st-electron.ru

Адрес: 198099, Санкт-Петербург,
Промышленная ул, дом № 19, литера Н,
помещение 100-Н Офис 331