



ADSP-SC589 EZ-Board® Evaluation System Manual

Contents

1	Preface	7
1.1	Product Overview	7
1.2	Purpose of This Manual	10
1.3	Intended Audience	10
1.4	Manual Contents	10
1.5	What's New in This Manual	11
1.6	Technical Support	11
1.7	Supported Processors	12
1.8	Supported Tools	12
1.9	Product Information	12
1.9.1	Analog Devices Web Site	12
1.9.2	EngineerZone	12
2	Using the ADSP-SC589 EZ-Board	14
2.1	Package Contents	15
2.2	ADSP-SC589 EZ-Board	15
2.3	Default Configuration	15
2.4	EZ-Board Installation	16
2.5	EZ-Board Session Startup	16
2.6	Evaluation License	18
2.7	DDR3 Memory	18
2.8	SPI Flash	19
2.9	SPI EEPROM Interface	19
2.10	Audio Interface	19
2.11	S/PDIF Interface	20
2.12	Housekeeping ADC	20
2.13	CAN Interface	20
2.14	UART Interface	21
2.15	Ethernet Interface	21
2.16	USB Interface	22
2.17	PCI Express Interface	22
2.18	Link Ports Interface	22
2.19	Current Monitor Interface	23
2.20	Programmable Oscillator	23
2.21	SD Interface	23
2.22	Debug Interface	23
2.23	Power-On-Self Test	24
2.24	Expansion Interface	24
2.25	Power Architecture	24
2.26	Power Measurements	25
2.27	Example Programs	25

2.28	Reference Design Information	25
3	ADSP-SC589 EZ-Board Hardware Reference	26
3.1	System Architecture	26
3.2	Software-Controlled Switches (SoftConfig)	27
3.2.1	Overview of SoftConfig	28
3.2.2	SoftConfig on the ADSP-SC589 EZ-Board	30
3.2.3	Programming SoftConfig Switches	31
3.3	Push Buttons and Switches	34
3.3.1	Boot Mode Select Switch (SW1)	35
3.3.2	Reset Push Button (SW2)	35
3.3.3	GPIO Push Buttons (SW3–4)	35
3.3.4	JTAG Interface Switches (SW6–7)	36
3.4	Jumpers	37
3.4.1	S/PDIF Loopback Jumper (JP1)	38
3.4.2	HADC Jumpers (J21)	38
3.4.3	Power Jumpers (P14–19, P23)	38
3.5	LEDs	38
3.5.1	SYS_FAULT LED (LED1)	39
3.5.2	USB to UART Activity LEDs (LED2–3)	39
3.5.3	Ethernet Speed LED (LED4)	39
3.5.4	Ethernet LEDs (LED5–8)	39
3.5.5	Power LED (LED9)	40
3.5.6	GPIO LEDs (LED10–12)	40
3.5.7	Reset LED (LED13)	40
3.6	Connectors	40
3.6.1	Battery Holder (J1)	41
3.6.2	Ethernet Connector (J2)	41
3.6.3	Link Port_JTAG Connectors (J3, J23)	41
3.6.4	S/PDIF Optical Tx Connector (J4)	42
3.6.5	PCIe Connector (J5)	42
3.6.6	Audio Input Output Connector (J6)	42
3.6.7	HADC Input Connectors (J7–J11)	43
3.6.8	CAN Connectors (J12–J13)	43
3.6.9	Ethernet Connector (J14)	43
3.6.10	S/PDIF Optical Rx Connector (J15)	43
3.6.11	Audio Output Connector (J16)	44
3.6.12	S/PDIF Digital Connector (J17)	44
3.6.13	SD Connector (J18)	44
3.6.14	ADC Connector (J19)	44
3.6.15	MLB Connector (J20)	45
3.6.16	Headphone Connector (J21)	45
3.6.17	CLKIN0 Connector (J22)	45
3.6.18	TWI0_SPI2 Connector (P1)	45
3.6.19	SigmaStudio Connector (P2)	46

3.6.20	JTAG Connector (P3)	46
3.6.21	TRACE and JTAG Connector (P7)	46
3.6.22	USB to UART Connector (P8)	46
3.6.23	USB Connectors (P10–P11)	46
3.6.24	Power Connector (P22)	47
3.6.25	Expansion Interface III Connectors (P1A–C, P2A, P3A)	47
4	Appendix A - Bill of Materials	48
5	Appendix B - Schematics	64

Copyright Information

© 2015 Analog Devices, Inc., ALL RIGHTS RESERVED. This document may not be reproduced in any form without prior, express written consent from Analog Devices, Inc.

Disclaimer

Analog Devices, Inc. reserves the right to change this product without prior notice. Information furnished by Analog Devices is believed to be accurate and reliable. However, no responsibility is assumed by Analog Devices for its use; nor for any infringement of patents or other rights of third parties which may result from its use. No license is granted by implication or otherwise under the patent rights of Analog Devices, Inc.

Trademark and Service Mark Notice

The Analog Devices logo, CrossCore, A²B, EngineerZone, EZ-Board, EZ-KIT Lite and VisualDSP++ are registered trademarks of Analog Devices, Inc. Blackfin, Blackfin+, SHARC, SHARC+ and SigmaStudio are trademarks of Analog Devices, Inc. All other brand and product names are trademarks or service marks of their respective owners.

Regulatory Compliance

The ADSP-SC589 EZ-Board is designed to be used solely in a laboratory environment. The board is not intended for use as a consumer end product or as a portion of a consumer end product. The board is an open system design which does not include a shielded enclosure and therefore may cause interference to other electrical devices in close proximity. This board should not be used in or near any medical equipment or RF devices.

The ADSP-SC589 EZ-Board is in the process of being certified to comply with the essential requirements of the European EMC directive 2004/108/EC and therefore carries the "CE" mark.



The ADSP-SC589 EZ-Board contains ESD (electrostatic discharge) sensitive devices. Electrostatic charges readily accumulate on the human body and equipment and can discharge without detection. Permanent damage may occur on devices subjected to high-energy discharges. Proper ESD precautions are recommended to avoid performance degradation or loss of functionality. Store unused EZ-Boards in the protective shipping package.



1 Preface

Thank you for purchasing the ADSP-SC589 EZ-Board®, Analog Devices, Inc. evaluation system for the ADSP-SC58x family of SHARC® processors.

The ADSP-SC589 processor is based on the SHARC+™ core dual processor with the ARM® Cortex-A5™ processor core and is designed for a wide array of markets, from automotive and pro-audio to industrial-based applications that require high floating-point performance. The EZ-Board is shipped with all of the necessary hardware—you can start the evaluation immediately. The package contains the standalone evaluation board, CE-approved power supply, and USB cable. The EZ-KIT Lite® version ships with the ICE-1000 emulator, while the EZ-Board version requires the customer to provide an ICE-1000 or ICE-2000 emulator.

Expansion Interface III connectors are provided for interfacing with additional extender boards to provide LCD, camera, video, and audio.

Traditional mechanical switches for changing the board's factory setup have been removed in favor of I2C controlled software switches. The only remaining mechanical switches are the boot mode switch, JTAG configuration switches, and push buttons.

The evaluation board is designed to be used in conjunction with the -CrossCore® Embedded Studio (CCES) development tools to test capabilities of the ADSP-SC58x processors. The development environment aids advanced application code development and debug, such as:

- Create, compile, assemble, and link application programs written in C++, C, and assembly
- Load, run, step, halt, and set breakpoints in application programs
- Read and write data and program memory
- Read and write core and peripheral registers

1.1 Product Overview

The board features:

- Analog Devices ADSP-SC589 processor
 - 529-ball 19 mm x 19 mm package
 - 25 MHz CLKIN0 and CLKIN1 programmable oscillator
- DDR3 memory
 - Two 128M x 16-bit (2G bit)
 - Micron MT41J128M16JT-125
- SPI Flash

- 128M bit
- Single, dual, and quad mode support
- Windbond W25Q128FV
- SPI EEPROM
 - 1K bit
 - Microchip 25LC010A
- Ethernet PHY (EMAC0)
 - 10/100/1000 Mb/s
 - Texas Instruments DP83865
 - RJ45 connector
- Ethernet PHY (EMAC1)
 - 10/100 Mb/s
 - Texas Instruments DP83848C
 - RJ45 connector
- Audio
 - Analog Devices ADAU1962A 12-channel, high-performance, 24-bit digital-to-analog converter
 - Analog Devices ADAU1979 quad analog-to-digital converter
 - 12 RCA connectors configurable as either 12 outputs or 8 outputs and 4 inputs
 - Headphone audio out connector
 - SPDIF in/out optical connectors
 - SPDIF in/out coax connectors
- Universal Asynchronous Receiver/Transmitter (UART0)
 - FTDI FT232RQ UAB to UART converter
 - USB micro AB connector
- Controller Area Network (CAN) interfaces
 - CAN0—NXP TJA1145 high speed transceiver for partial networking
 - CAN1—NXP TJA1055 enhanced fault tolerant transceiver
 - Two RJ11 connectors
- USB interfaces
 - USB OTG micro AB connector

- USB HS micro AB connector
- HADC
 - 0.1" and SMB connectors
- PCIe
 - PCIe x 1 connector
- RESET controller
 - Analog Devices ADM6315 microprocessor supervisory circuits
- Debug (JTAG/SWD/SWO/TRACE) interface
 - JTAG 10-pin 0.05" header for use with Analog Devices emulator
 - TRACE/JTAG 38-pin Mictor header
- Power measurements
 - INA3221 to measure 3V, VDD_INT, and VDD_EXT
- LEDs
 - 13 LEDs: one power (green), one board reset (red), seven Ethernet (green and amber), one SYS_FAULT (red), and three general-purpose (amber)
- Push buttons
 - Three push buttons: one reset, and two IRQ/Flag
- Expansion Interface III connectors (EI3)
 - SMC0
 - PPI
 - SPORT
 - SPI
 - UART
 - TWI
 - TMR
 - GPIOs
 - PWR_IN
 - GND/3.3V output
- External power supply
 - CE compliant
 - 5V @ 3.6 amps

- Other features
 - SD/MMC memory connector
 - SigmaStudio™ connectors
 - 0.05-ohm resistors for processor current measurement

For information about the hardware components of the EZ-Board, refer to [Appendix A - Bill of Materials](#)

1.2 Purpose of This Manual

The ADSP-SC589 EZ-Board Evaluation System Manual provides instructions for installing the product hardware (board). The text describes operation and configuration of the board components and provides guidelines for running your own code on the ADSP-SC589 EZ-Board. Finally, a schematic and a bill of materials are provided for reference.

1.3 Intended Audience

The primary audience for this manual is a programmer who is familiar with an ARM Cortex-A5-based processor core and a SHARC-based processor core.

The ADSP-SC58x family of SHARC+ processors is based on the ARM Cortex-A5/SHARC processor core with floating-point unit and integrated SRAM memory, flash memory, accelerators, and peripherals.

The applicable documentation for programming the ARM Cortex-A5 processor core includes:

- Cortex-A5 Devices Generic User Guide
- CoreSight ETM-A5 Technical Reference Manual
- Cortex-A5 Technical Reference Manual

For additional information on this Analog Devices processor, see the ADSP-SC58x SHARC+ Processor Hardware Reference. This document describes the ARM Cortex-A5 processor core and memory architecture used on the ADSP-SC58x processor, but does not provide detailed programming information for the ARM core.

For more information about programming the ARM core, visit the ARM Information Center:

- <http://infocenter.arm.com/help/>

1.4 Manual Contents

The manual consists of:

Chapter 1 Using ADSP-SC589 EZ-Board

- Describes EZ-Board functionality from a programmer's perspective and provides a simplified memory map of the processor.

Chapter 2 ADSP-SC589 EZ-Board Hardware Reference

- Provides information about the EZ-Board hardware components.

Appendix A ADSP-SC589 EZ-Board Bill Of Materials

- Provides a list of hardware components used to manufacture the EZ-Board.

Appendix B ADSP-SC589 EZ-Board Schematic

- Lists the resources for board-level debugging.

1.5 What's New in This Manual

This is the first edition (Revision 1.0) of the ADSP-SC589 EZ-Board Evaluation System Manual.

1.6 Technical Support

You can reach Analog Devices processors and DSP technical support in the following ways:

- Post your questions in the processors and DSP support community at EngineerZone®:
<http://ez.analog.com/community/dsp>
- Submit your questions to technical support directly at:
<http://www.analog.com/support>
- E-mail your questions about processors and processor applications to:
processor.support@analog.com or processor.china@analog.com (Greater China support)
- Contact your Analog Devices sales office or authorized distributor.
www.analog.com/adi-sales
- Send questions by mail to:

Processors and DSP Technical Support
Analog Devices, Inc.
Three Technology Way
P.O. Box 9106
Norwood, MA 02062-9106
USA

1.7 Supported Processors

This evaluation system supports Analog Devices ADSP-SC589 processors.

1.8 Supported Tools

Information on supported tools for the ADSP-SC589 EZ-Board and the ADSP-SC58x family of processors is available at: <http://www.analog.com/sc589ezboard>

1.9 Product Information

Product information can be obtained from the Analog Devices Web site and the online help system.

1.9.1 Analog Devices Web Site

The Analog Devices Web site, www.analog.com, provides information about a broad range of products—analog integrated circuits, amplifiers, converters, and digital signal processors.

To access a complete technical library for each processor family, go to http://www.analog.com/processors/technical_library. The manuals selection opens a list of current manuals related to the product as well as a link to the previous revisions of the manuals. When locating your manual title, note a possible errata check mark next to the title that leads to the current correction report against the manual.

Also note, myAnalog.com is a free feature of the Analog Devices Web site that allows customization of a Web page to display only the latest information about products you are interested in. You can choose to receive weekly e-mail notifications containing updates to the Web pages that meet your interests, including documentation errata against all manuals. myAnalog.com provides access to books, application notes, data sheets, code examples, and more.

Visit myAnalog.com (found on the Analog Devices home page) to sign up. If you are a registered user, just log on. Your user name is your e-mail address.

1.9.2 EngineerZone

EngineerZone is a technical support forum from Analog Devices. It allows you direct access to ADI technical support engineers. You can search FAQs and technical information to get quick answers to your embedded processing and DSP design questions.

Use EngineerZone to connect with other DSP developers who face similar design challenges. You can also use this open forum to share knowledge and collaborate with the ADI support team and your peers. Visit <http://ez.analog.com> to sign up.

2 Using the ADSP-SC589 EZ-Board

This chapter provides information to assist you with development of programs for the ADSP-SC589 EZ-Board evaluation system.

The following topics are covered.

- Package Contents
- ADSP-SC589 EZ-Board
- Default Configuration
- EZ-Board Installation
- EZ-Board Session Startup
- Evaluation License
- DDR3 Memory
- SPI Flash
- SPI EEPROM Interface
- Audio Interface
- S/PDIF Interface
- Housekeeping ADC
- CAN Interface
- UART Interface
- Ethernet Interface
- USB Interface
- PCI Express Interface
- Link Ports Interface
- Current Monitor Interface
- Programmable Oscillator
- SD Interface
- Debug Interface
- Power-On-Self Test
- Expansion Interface
- Power Architecture

- [Power Measurements](#)
- [Example Programs](#)
- [Reference Design Information](#)

2.1 Package Contents

Your ADSP-SC589 EZ-Board package contains the following items.

- ADSP-SC589 EZ-Board PCB
- Universal 5V DC power
- Ethernet cable
- USB A to micro B cable
- USB micro A to A receptacle cable
- ICE-1000 (only in the EZ-KIT Lite version)
- Standoffs and screws in a bag
- Release note
- 2GB SD card

Contact the vendor where you purchased your EZ-Board or contact Analog Devices, Inc. if any item is missing.

2.2 ADSP-SC589 EZ-Board

The ADSP-SC589 EZ-KIT Lite is shipped with an ICE-1000 emulator. When the product is not shipped with the debugger, it is referred to as the ADSP-SC589 EZ-Board.





The EZ-Board requires an ICE-1000 or ICE-2000 emulator.

2.3 Default Configuration

The ADSP-SC589 EZ-Board is designed to run as a standalone unit.

The image below shows the default jumper settings, connector locations, and LEDs used in installation. Confirm that your board is in the default configuration before using the board.

- Navigate to the CCES environment through the **Start** menu. Note that CCES is not connected to the target board.
- Use the Debug Configurations wizard to connect to the EZ-Board. If a debug configuration exists already, select the appropriate -configuration and click **Debug**. Go to step 8.
- To create a debug configuration, do one of the following:
 - Click the down arrow next to the bug icon  , select **Debug Configurations**.
 - Choose **Run > Debug Configurations**.
 - The **Debug Configuration** dialog box appears.
 - Select **Application with CrossCore Debugger** and click  (**New launch configuration**). The **Select Processor** page of the **Session Wizard** appears.
 - Ensure **SHARC** is selected in **Processor family**. In **Processor type**, select **ADSP-SC589**. Click **Next**. The **Select Connection Type** page of the **Session Wizard** appears.
 - Select **Emulator** and click **Next**.
 - The **Select Platform** page of the **Session Wizard** appears.
 - Choose the type of emulator that is connected to the EZ-Board.
 - Click **Finish** to close the wizard. The new debug configuration is created and added to the Debug Configurations list.
 - In the **Name** edit box, users can select an appropriate name to describe the configuration, otherwise a default name is provided.
 - In the **Program(s) to load** section, choose the program to load (if the appropriate program is not already populated) when connecting to the board. If not loading any program upon connection to the target, do not make any changes.

NOTE: Notice that by default there is an application loaded to Core 0 that is not the application created by the user. This is a preload application that is used to set up external memory since Core 0 applications are loaded to L3 memory by default. This preload can be changed if needed but will work for most applications. User applications loaded after a preload should NOT reset as they may undo some of what the preload has already set up.

- While connected to the target, there is no way to choose a program to download. To load a program once connected, terminate the session and then load the new program.
- To delete a configuration, go to the **Debug Configurations** dialog box and select the configuration to delete. Click  and choose **Yes** when asked if you wish to delete the selected launch configuration. Then **Close** the dialog box.

- To disconnect from the target board, click the terminate button  or choose **Run > Terminate**. To delete a session, choose **Target > Session > Session List**. Select the session name from the list and click **Delete**. Click **OK**.
- The default configurations that show up in the CCES Debug Configurations wizard are for JTAG mode debugging only.

2.6 Evaluation License

When starting CCES for the first time, you are prompted to install a license with a serial number or to enable evaluation of the product without a serial number. In the box that contains the EZ-Board is a business card with a serial number on it. When prompted, choose "I have a serial number that I would like to activate" and enter the serial number shown on the card. If the evaluation license is installed but not activated, it allows 10 days of unrestricted use and then becomes disabled. The license can be re-enabled by activation. Once activated, the evaluation license offers unrestricted use for a defined period and then becomes disabled until an additional license is installed.



if installing CCES without using a serial number, you will be limited to 90 days.

An evaluation license can be upgraded to a full license. Licenses can be purchased from:

- Analog Devices directly. Call (800) 262-5645 or 781-937-2384 or go to: <http://www.analog.com/buyonline>.
- Analog Devices, Inc. local sales office or authorized distributor. To locate one, go to: www.analog.com/adi-sales.

2.7 DDR3 Memory

There are two Dynamic Memory Controllers (DMC) on the ADSP-SC589 processor. Each one connects to a 2Gb Micron MT41K128M16JT chip through the Double Data Rate Synchronous Dynamic Random-Access Memory (DDR3 SDRAM) controller. The DDR3 memory controller on the processor and the DDR3 memory chip are powered by the on-board 1.5V regulator. Data is transferred between the processor and DDR3 on both the rising and falling edges of the DDR3 clock. The DDR3 controller on the processor can operate up to a maximum clock frequency of 450 MHz.

With a CCES session running and connected to the EZ-Board through an emulator, the DDR3 registers are configured automatically each time a program is loaded through the use of the preload program.

An example program is included in the ADSP-SC589 Board Support Package to demonstrate how to set up and access the DDR3 interface. For more information on how to initialize the registers after a reset, refer to the hardware reference manual.

2.8 SPI Flash

The ADSP-SC589 processor has three SPI interfaces: SPI0, SPI1, and SPI2. SPI2 is connected to a Winbond W25Q128FV 128 Mb serial flash memory with dual and quad SPI support. This flash is used for booting and scratchpad space.

Quad mode is enabled by default. The processor flag signals PC_06 (SPI2_SEL1), PC_04 (SPI2_D2), and PC_05 (SPI2_D3) are connected by default and can be disconnected by using SoftConfig. Refer to [Software-Controlled Switches \(SoftConfig\)](#) for more information.

For more information, refer to the SPI flash example in the POST, which is included in the ADSP-SC589 Board Support Package.

2.9 SPI EEPROM Interface

The ADSP-SC589 processor has three SPI interfaces: SPI0, SPI1, and SPI2. SPI0 is connected to a Microchip 25LC010A 1 Kb serial flash electronically erasable programmable only memory. This flash is used for storing configuration data for EAVB.

The SPI EEPROM is disabled by default. The processor flag signal PD_01 (SPI0_SEL2) is not connected by default and can be connected by using SoftConfig. Refer to [Software-Controlled Switches \(SoftConfig\)](#) for more information.

For more information, refer to the SPI flash EEPROM example in the POST, which is included in the ADSP-SC589 Board Support Package.

2.10 Audio Interface

The ADSP-SC589 EZ-Board contains an ADC and a DAC. The ADAU1979 is a quad analog-to-digital converter. The ADC incorporates four high-performance analog-to-digital converters. This converter uses a multi-bit sigma-delta architecture with continuous time front-end for low EMI. The ADAU1979 contains an SPI port which is used as a control port to adjust volume and many other parameters. The ADAU1962A is a 12-channel high-performance digital-to-analog converter. The DAC uses a multi-bit sigma-delta architecture and is designed for low EMI. This converter contains an SPI port which is used as a control port to adjust volume and other parameters.

The EZ-Board is configurable for either 12 outputs or 8 outputs and 4 inputs. Configuration is performed through SoftConfig. The audio channels are available as single-ended RCA connectors J6 and J16. One output channel is also available on a 3.5mm headphone jack (J21).

For more information, refer to the audio example in the POST, which is included in the ADSP-SC589 Board Support Package.

2.11 S/PDIF Interface

The ADSP-SC589 processor has two built-in S/PDIF transmitters and receivers for digital audio applications. The EZ-Board supports one S/PDIF interface and connects to the transmitter and receiver through RCA and optical connectors J17, J15, J17, and J4.

The transmit and receive pins of the S/PDIF are connected to DAI pins through SoftConfig. DAI0_PIN19 is connected to S/PDIF receive and DAI0_PIN20 is connected to S/PDIF transmit. Refer to [Software-Controlled Switches \(SoftConfig\)](#) for more information.

For more information, refer to the S/PDIF example in the POST, which is included in the ADSP-SC589 Board Support Package.

2.12 Housekeeping ADC

The ADSP-SC589 processor provides eight housekeeping ADC inputs— HADC0_VIN0 through HADC_VIN7. The EZ-Board connects HADC0_VIN0 to pin 1, HADC0_VIN1 to pin 4, and HADC0_VIN2 to pin 5 of a six-position 0.1" header (P21). P21 has the 3.3V voltage domain on pin 1, 1.5V voltage domain on pin 3, and VDD_INT voltage domain on pin 6, allowing a jumper to connect the voltage back to the processor.

HADC_VIN3 through HADC_VIN5 are connected to SMB connectors (J7, J8, and J8). HADC_VIN6 and HADC_VIN7 are connected to SMB connectors (J8 and J8) through a 1:1 buffer.

For more information, refer to the HADC example in the POST, which is included in the ADSP-SC589 Board Support Package.

2.13 CAN Interface

The ADSP-SC589 processor has two CAN instances. Both are used by the EZ-Board.

The Controller Area Network 0 (CAN0) interface of the EZ-Board is connected to the NXP TJA1055 /3 enhanced fault-tolerant CAN transceiver. The transceiver is attached to the CAN0 port of the ADSP-SC589 processor through an RJ-11 connector (J12). See [CAN Connectors \(J12–J13\)](#).

The CAN0 transmit, receive, and control signals are connected through the SoftConfig switches and disabled by default. CAN0_EN is connected to -PB_08. CAN0_STB is connected to PB_02. CAN0_ERR is connected to PB_07. See [Software-Controlled Switches \(SoftConfig\)](#).

For more information, refer to the CAN0 example in the POST, which is included in the ADSP-SC589 Board Support Package.

The Controller Area Network 1 (CAN1) interface of the EZ-Board is connected to the NXP TJA1145 high speed CAN transceiver for partial networking. The transceiver is attached to the CAN1 and SPI0 port of the ADSP-SC589 processor through an RJ-11 connector (J13). See [CAN Connectors \(J12–J13\)](#).

The CAN1 transmit and receive signals are connected through the SoftConfig switches and enabled by default. See [Software-Controlled Switches \(SoftConfig\)](#).

For more information, refer to the CAN1 example in the POST, which is included in the ADSP-SC589 Board Support Package.

2.14 UART Interface

The ADSP-SC589 processor has three built-in universal asynchronous transmitters (UARTs). UART0 is connected to an FTDI, FT232RQ, USB to UART converter IC.

The UART functionality is connected by default through SoftConfig. Refer to [Software-Controlled Switches \(SoftConfig\)](#) for more information.

For more information, refer to the UART example in the POST, which is included in the ADSP-SC589 Board Support Package.

2.15 Ethernet Interface

The ADSP-SC589 processor has two Ethernet Media Access Controller interfaces. EMAC0 is configurable as 10 Mbps/100 Mbps (interfacing through RMII) or 1 Gbps (interfacing through RGMII). It supports IEEE 1588 and AVB. EMAC1 is 10 Mbps/100 Mbps (interfacing through RMII).

On the EZ-Board, EMAC0 is connected to a Texas Instruments DP83865 PHY. It is configured to operate in RGMII-3COM mode. The PHY supports 10BASE-T, 100BASE-TX, and 1000BASE-T Ethernet protocols.

On the board, EMAC1 is connected to a Texas Instruments DP83848C PHY. It is configured to operate in RMII mode. The PHY supports 10BASE-T and 100BASE-TX Ethernet protocols.

For more information, refer to the Ethernet example in the POST, which is included in the ADSP-SC589 Board Support Package.

2.16 USB Interface

The ADSP-SC589 processor has two instances of USB controllers. One supports USB 2.0 HS On-The-Go (OTG) and the other supports USB 2.0 HS device mode only. The EZ-Board provides two micro AB connectors. The board supplies a maximum of 5V at 500 mA to a peripheral device when connecting to the OTG connector by enabling a FET switch. The USB controller oversees the FET switch through the USB0_VBC signal.

For more information, refer to the USB example in the POST, which is included in the ADSP-SC589 Board Support Package.

2.17 PCI Express Interface

The ADSP-SC589 processor has one instance of PCIe. The PCIe port can operate as a Root Complex and as an End Point. In each one of these modes it can operate as a Gen1 2.5 GT/s or as a Gen2 5.0 GT/s.

The board is configured by default to operate in EP (Endpoint) mode. In this mode a cable is required to connect the SC589 EZ-Board with a RC (Root Complex) host. Refer to [PCIe Connector \(J5\)](#) for more information. In order to use the SC589 EZ-Board in RC mode some changes are required to the board. If a clock signal is required to be present on the PCIe connector then 0 ohm resistors need to be populated at locations R417 and R418. The location of these resistors can be found by looking at the layout data in the [Reference Design Information](#). A modified PCIe cable is also required in this mode. Please contact Analog Devices for more information about this mode and how to acquire a cable.

2.18 Link Ports Interface

The ADSP-SC589 processor has two dedicated link ports. Each link port has a clock pin, an acknowledgment pin, and eight data pins. The ports can operate at up to 150 MHz and act as either receivers or transmitters. The ports are used to interface gluelessly to other ADSP-SC589 processors which also have the link ports pins brought out to a connector.

The EZ-Board enables access to link ports 0 and 1 through connectors J3 and J23, respectively. Two ADSP-SC589 EZ-Boards can mate gluelessly through the link port connectors using an off-the-shelf cable from Samtec. The processors communicate through the link ports, all while performing independent tasks on each of the EZ-Boards. To loopback the link port connectors on one EZ-Board to another, obtain a standard, off-the-shelf cable from Samtec. For more information, see [Link Port_JTAG Connectors \(J3, J23\)](#).

2.19 Current Monitor Interface

The ADSP-SC589 EZ-Board contains a Texas Instruments INA3221 triple-channel, high-side measurement, shunt, and bus voltage monitor. The INNA3221 monitors both shunt voltage drops and bus supply voltages in addition to having programmable conversion times and averaging modes for these signals. It offers both critical and warning alerts to detect out-of-range conditions for each channel. This device is connected to the ADSP-SC589 processor through TWI0. The device is used to measure the voltage levels and current draw from 1.5V (DDR3), VDD_INT, and VDD_EXT.

For more information, refer to the example in the POST, which is included in the ADSP-SC589 Board Support Package.

2.20 Programmable Oscillator

The ADSP-SC589 EZ-Board contains a Silicon Labs Si5356A I2C programmable, quad output clock generator. This device generates clocks for the CLKIN0 and CLKIN1 inputs for the ADSP-SC589 processor. It also generates the CLKIN for the ADAU1962A. When the board powers up, the CLKIN0 and CLKIN1 signals default to 25 MHz and the ADAU1962A_CLKIN defaults to 24.576 MHz. The Si5356A connects to the ADSP-SC589 processor through TWI0. Different frequencies can be programmed into the part by using the Silicon Labs ClockBuilder desktop software available [here](#).

For more information, refer to the example in the POST, which is included in the ADSP-SC589 Board Support Package.

2.21 SD Interface

The ADSP-SC589 processor has a secure digital (SD) interface that consists of a clock pin, command pin, card detect pin, and an 8-bit data bus. SoftConfig controls the connection a GPIO pin used for write protect (PC_15). Refer to [Software-Controlled Switches \(SoftConfig\)](#) and [SD Connector \(J18\)](#) for more details.

For more information, refer to the example in the POST, which is included in the ADSP-SC589 Board Support Package.

2.22 Debug Interface

The EZ-Board provides a JTAG connection through a connector (P3), which is a 0.05" pitch header. A 16-bit trace connection also is available through a connector (P2), although this is not supported at this time. See [JTAG Connector \(P3\) and TRACE and JTAG Connector \(P7\)](#) for more information.

2.23 Power-On-Self Test

The Power-On-Self-Test (POST) program tests all EZ-Board peripherals and validates functionality as well as connectivity to the processor. Once assembled, each EZ-Board is fully tested for an extended period of time with POST. All EZ-Boards are shipped with POST burned into flash memory. The POST is executed by resetting the board and pressing the proper push button(s) sequence. The POST also can be used as a reference for a custom software design or hardware troubleshooting.

The source code for the POST program is included in the ADSP-SC589 Board Support Package along with the readme.txt file that describes how to configure the board run POST.

2.24 Expansion Interface

The expansion interface allows a custom-design daughter board to be tested across various hardware platforms that have the same expansion interface.

The Expansion Interface III (EI3) implemented on the ADSP-SC589 EZ-Board consists of five connectors: P1A, P1B, P1C, P2A, and P3A. The connectors contain a majority of the processor's signals. For pinout information, go to [Appendix B - Schematics](#).

Limits to current and interface speed must be taken into consideration when using the expansion interface. Current for extenders connected to the EI3 connectors can be sourced from the EZ-Board; therefore, the current should be limited to 250 mA for 5V, and 300 mA from the 3.3V planes. If more current is required, a separate power connector and a regulator must be designed on the daughter card. Additional circuitry implemented on extender cards can add extra loading to signals, decreasing their maximum effective speed.



Analog Devices does not support and is not responsible for the effects of additional circuitry.

2.25 Power Architecture

The ADSP-SC589 EZ-Board has four primary voltage domains: 1.1V, 1.5V, 1.8V and 3.3V. The power input is a 5V wall adaptor.

The Analog Devices ADP5054 controller provides four voltage levels—3.3V for the VDD_EXT signal and the 3.3V power requirements of the board, 1.1V for the VDD_INT signal, 1.5V for the DDR3 interface and 1.8V for the DP83865 PHY.

The voltage levels can be measured using the INA3221 IC for 3.3V, VDD_INT, and 1.5V. Current consumption of the power rail could be measured with this same device when the corresponding jumper is removed. See [Power Measurements](#) for more information.

2.26 Power Measurements

Locations are provided for measuring the current draw from various power planes. Precision 0.05 ohm shunt resistors are available on the VDD_EXT, VDD_INT, USB0_VBUS, and 3.3V and voltage domains. For measuring current draw, the jumper is removed, voltage across the resistor can be measured using an oscilloscope, and the value of the resistor can be measured using a precision multi-meter. Once voltage and resistance are measured, the current can be calculated by dividing the voltage by the resistance. For the highest accuracy, a differential probe should be used for measuring the voltage across the resistor.

2.27 Example Programs

Example programs are provided with the ADSP-SC589 Board Support Package to demonstrate various capabilities of the product.

The programs can be found in the ADSP-SC589_EZ-Board-Rel1.0.0\examples folder. The number after the "Rel" could be higher for newer versions. Refer to a readme file provided with each example for more information.

2.28 Reference Design Information

A reference design info package is available for download on the Analog Devices Web site. The package provides information on the design, layout, fabrication, and assembly of the EZ-Board.

The information can be found at: <http://www.analog.com/sc589ezboard>

3 ADSP-SC589 EZ-Board Hardware Reference

This chapter describes the hardware design of the ADSP-SC584 EZ-Board.

The following topics are covered.

- [System Architecture](#) - Describes the board's configuration and explains how the board components interface with the processor.
- [Software-Controlled Switches \(SoftConfig\)](#) - Lists and describes the processor signals routed through the software-controlled switches.
- [Push Buttons and Switches](#) - Shows the locations and describes the push buttons and switches.
- [Jumpers](#) - Shows the locations and describes the configuration jumpers.
- [LEDs](#) - Shows the locations and describes the LEDs.
- [Connectors](#) - Shows the locations and provides part numbers for the on-board connectors

3.1 System Architecture

This section describes the processor's configuration on the EZ-Board.

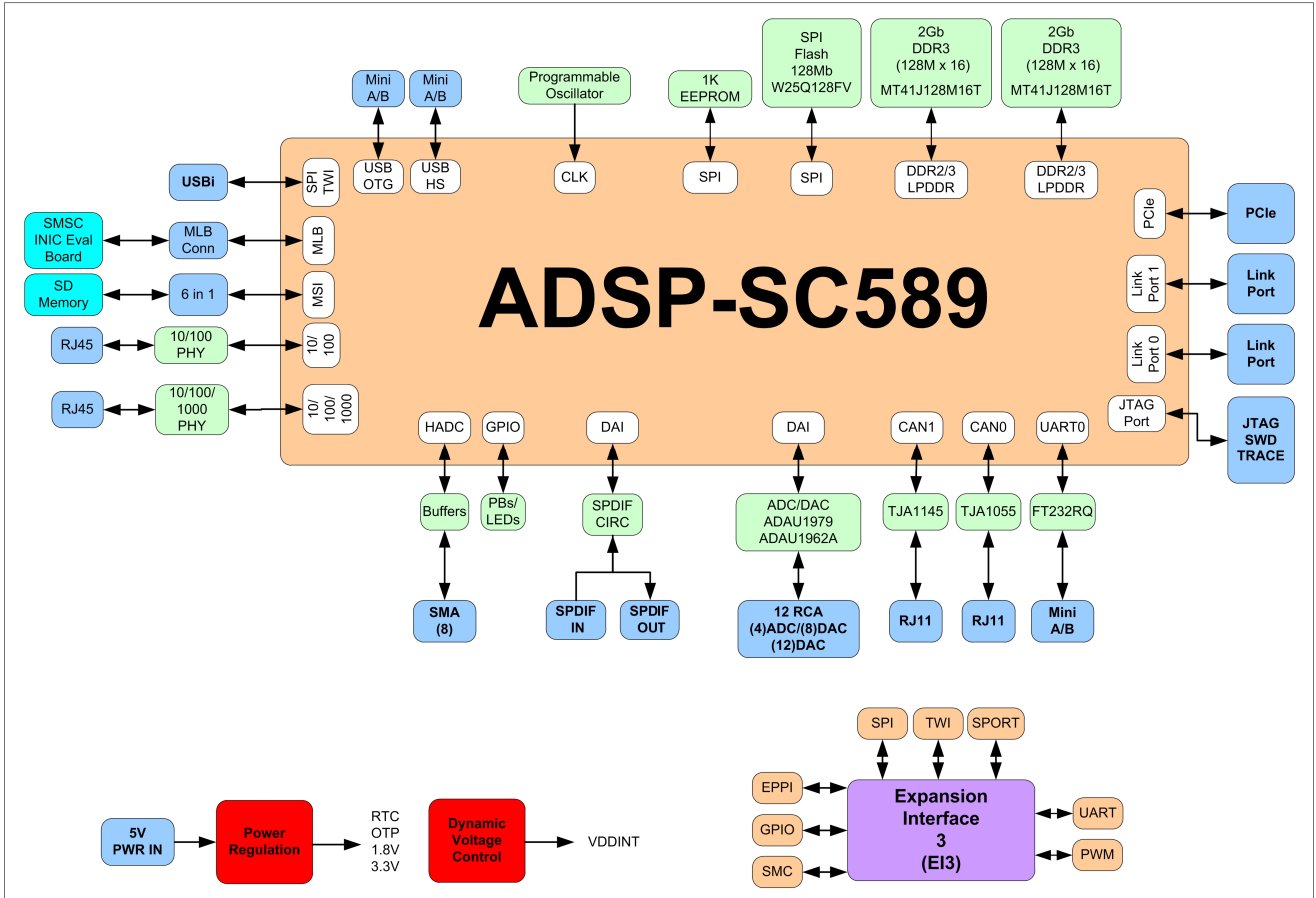

The ADSP-SC589 EZ-Board has two 25 MHz input clocks and runs at a max core clock frequency of 450 MHz. The input clock frequency can be changed through the SI5356A I2C programmable clock generator.

3.2 Software-Controlled Switches (SoftConfig)

On the ADSP-SC589 EZ-Board, most of the traditional mechanical switches have been replaced by I2C software-controlled switches. The remaining mechanical switches are provided for the boot mode and push buttons. Reference any SoftConfig*.c file found in the installation directory for an example of how to set up the SoftConfig feature of the ADSP-SC589 EZ-Board through software.

The SoftConfig section of this manual serves as a reference to any user that intends to modify an existing software example. If software provided from ADI is used, there should be little need to reference this section.

i Care should be taken when changing SoftConfig settings not to create a conflict with interfaces. This is especially true when connecting extender cards.

3.2.1 Overview of SoftConfig

In order to further clarify the use of electronic single FET switches and multi-channel bus switches, an example of each is illustrated and compared to a traditional mechanical switching solution. This is a generic example that uses the same FET and bus switch components that are on the EZ-Board.

After this generic discussion there is a detailed -explanation of the SoftConfig interface specific to the ADSP-SC589 EZ-Board.

The circuit below shows two individual FET switches (Pericom PI3A125CEX) with reference designators UA and UB. Net names ENABLE_A and ENABLE_B control UA and UB. The default FET switch enable settings in this example are controlled by resistors RA and RB which pull the enable pin 1 of UA and UB to ground (low). In a real example, these enable signals are controlled by the Microchip IO expander. The default pull-down resistors connect the signals EXAMPLE_SIGNAL_A and EXAMPLE_SIGNAL_B and also connect signals EXAMPLE_SIGNAL_C and EXAMPLE_SIGNAL_D. To disconnect EXAMPLE_SIGNAL_A from EXAMPLE_SIGNAL_B, the Microchip IO expander is used to change ENABLE_A to a logic 1 through software that interfaces with the Microchip. The same procedure for ENABLE_B would disconnect EXAMPLE_SIGNAL_C from EXAMPLE_SIGNAL_D.

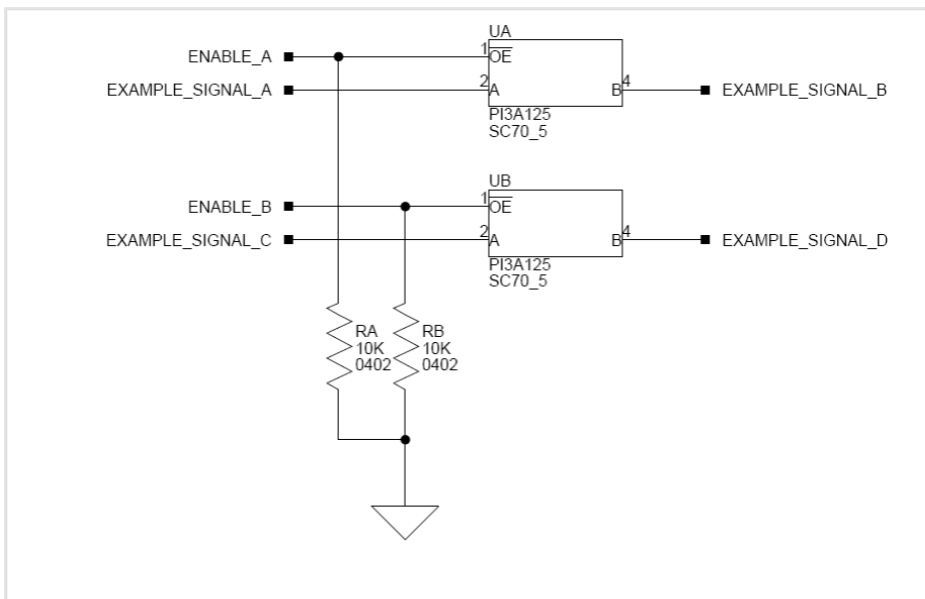

The image below shows the equivalent circuit as above but utilizes mechanical switches that are in the same package. Notice the default is shown by black boxes located closer to the ON label of the switches. In order to disconnect these switches, physically move the switch to the OFF position.

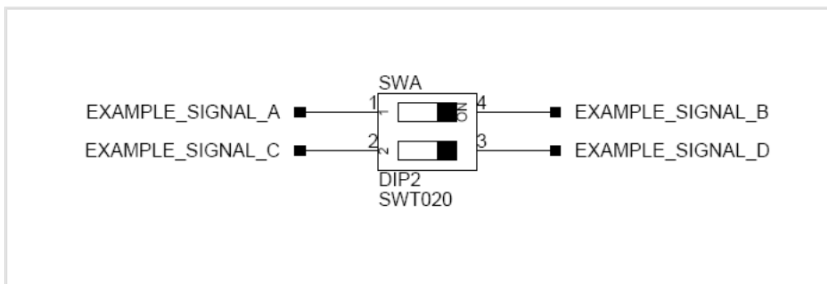

The circuit below shows a bus switch example, reference designator UC (Pericom PI3LVD512ZHE), selecting between lettered functionality and numbered functionality. The signals on the left side are multiplexed signals with naming convention letter_number. The right side of the circuit shows the signals separated into letter and number, with the number on the lower group (eg. 0B1) and the letter on the upper group (eg. 0B2). The default setting is controlled by the signal CONTROL_LETTER_NUMBER which is pulled low. This selects the number signals on the right to be connected to the multiplexed signals on the left by default. In this example, the Microchip IO expander is not shown but controls the signal CONTROL_LETTER_NUMBER and allows the user to change the selection through software.

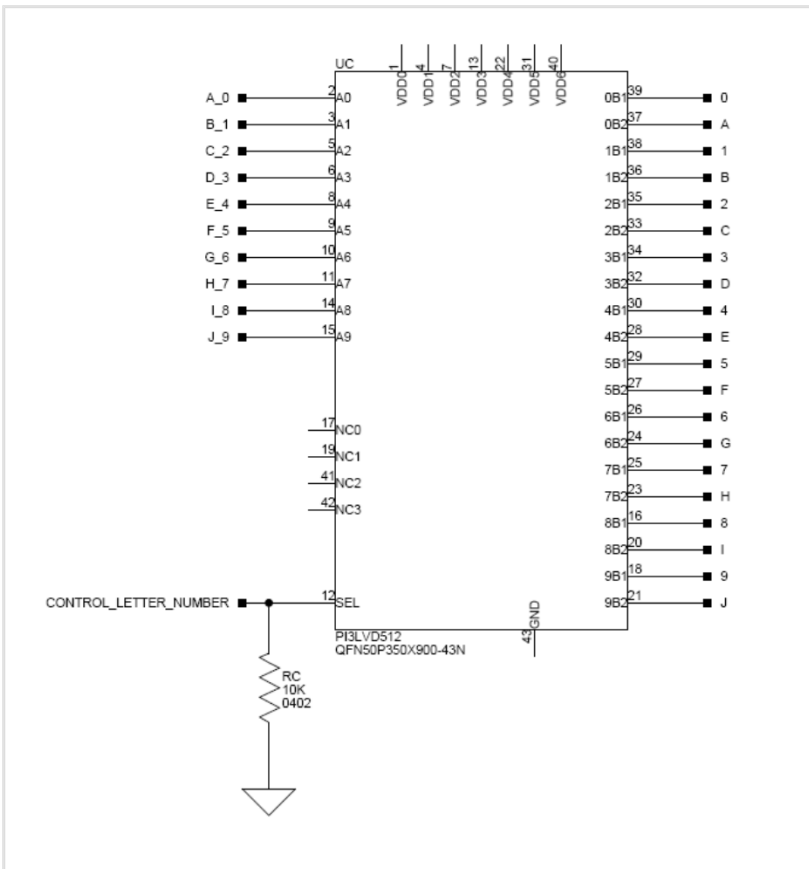

The image below shows the equivalent circuit as above but utilizes mechanical switches. Notice the default for reference designators SWC and SWD is illustrated by black boxes located closer to the ON label of the switches to enable the number signals by default. Also notice the default setting for reference designators SWE and SWF is OFF. In order to connect the letters instead of the numbers, the user physically changes all switches on SWC and SWD to the OFF position and all switches on SWE and SEF to the ON position.

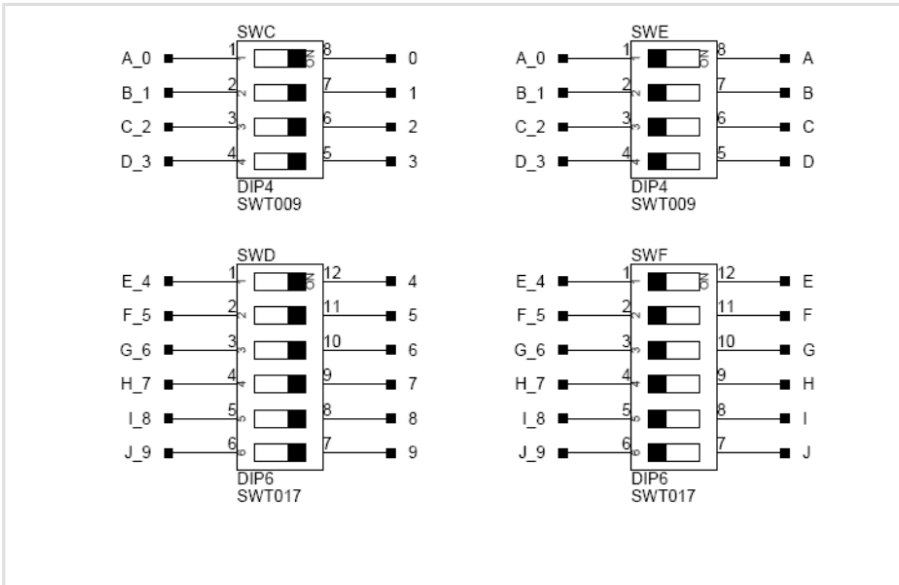

3.2.2 SoftConfig on the ADSP-SC589 EZ-Board

Two Microchip MCP23017 GPIO expanders provide control for individual electronic switches. The TWI0 interface of the processor communicates with the Microchip devices.

Note that only interfaces affected by software switches are listed.

Default ADSP-SC589 Processor Interface Availability	
Interface	Availability by Default
UART0	USB to UART FTDI232RQ
EMAC0	RGMII interface enabled
EMAC1	RMII interface enabled
SPI Flash	Quad mode enabled
Audio Connectors	4 inputs/8 outputs
SD Card	Write protect enabled
S/PDIF Digital	S/PDIF RCA input and output connectors enabled
Push buttons	Enabled

Default ADSP-SC589 Processor Interface Availability	
LEDs	Enabled

3.2.3 Programming SoftConfig Switches

On the ADSP-SC589 EZ-Board, two Microchip MCP23017 devices exist. Each of these devices have the following programming characteristics:

Each switch has two programmable GPIO registers.

GPIO Register	Register Address
GPIOA	0x12
GPIOB	0x13

Each GPIO register controls eight signals (software switches).

- By default, the Microchip MCP23017 GPIO signals function as input signals.
- The signals must be programmed as output signals to override their default values. The following table shows the Microchip register addresses and the values that must be written to them to program the signals as output signals.

IODIR Register	IODIR Register Address	Value to be Written to Program Signals as Outputs
IODIRA	0x00	0
IODIRB	0x01	0

Each of the examples in the ADSP-SC58x Board Support Package include source files that program the soft switches, even if the default settings are being used. The README for each example identifies only the signals that are being changed from their default values. The code that programs the soft switches is located in the SoftConfig_SC589.c file in each example.

The following tables outline the default values for each of the two Microchip MCP23017 devices.

GPIO	MCP23017 Register Address	Default Value
GPIOA	0x12	0xE0
GPIOB	0x13	0x00

GPIO	MCP23017 Register Address	Default Value
GPIOA	0x12	0xB9
GPIOB	0x13	0x3F

The ADSP-SC589 EZ-Board Schematic shows how the two Microchip GPIO expanders are connected to the board's ICs.

The tables below show the output signals of the Microchip GPIO expander (U47), with a TWI address of 0100 001X, where X represents the read or write bit. The signals that control an individual FET have an entry under the **FET** column. The **Component Connected** column shows the board IC that is connected if the FET is enabled. The Microchip (U47) is controlling the enable signal of a FET switch. Also note that if a particular functionality of the processor signal is being used, it will be in **bold font** under the **Processor Signal** column.

Output Signals of Microchip GPIO Expander (U47 Port A)

Bit	Signal Name	Description	FET	Processor Signal (if applicable)	Component Connected	Default
0	EEPROM_EN	SPI EEPROM CS	U9	PD_01/ SPI0_SEL2 / ACM0_A4/SMC0_AOE/ SPI0_SS	U40	High
1	UART0_FLOW_EN	UART0 Flow Control	U26	PC_15/ UART0_RTS / PPI0_FS3/ACM0_A2/ SMC0_AMS0, PD_00/ UART0_CTS / PPI0_D23 /ACM0_A3/ SMC0_D07	U7	High
2	UART0_EN	Enables UART0	U26	PC_13/ UART0_TX / SPI1_SEL1/ACM0_A0, PC_14/ UART0_RX / ACM0_A1/TM0_ACIO	U7	Low
3	ETH0_EN	Enables Ethernet 0	U2, U29	EMAC0 signals	U46	Low
4	ETH1_EN	Enables Ethernet 1	U28	EMAC1 signals	U51	Low
5	MLB3_EN	Enables MLB3		None	J20	High

Bit	Signal Name	Description	FET	Processor Signal (if applicable)	Component Connected	Default
6	CAN0_EN	Enables CAN0	U4	CAN0 signals	U33	High
7	CAN1_EN	Enables CAN1	U4	CAN1 signals	U43	High

Output Signals of Microchip GPIO Expander (U47 Port B)

Bit	Signal Name	Description	FET	Processor Signal (if applicable)	Component Connected	Default
0	ADAU1962_EN	Enables ADAU1962	U5	DAI1_PIN02, DAI1_PIN04, DAI1_PIN01, DAI1_PIN05	U8	High
1	ADAU1979_EN	Enables ADAU1979	U5	DAI1_PIN12, DAI1_PIN20, DAI1_PIN06, DAI1_PIN07	U42	High
2	AUDIO_JACK_SEL	Selects between connec- tor being configured for input or output	U41	None	J6	High
3	SD_WP_EN	SD Card Write Protect	U10	PC_15/UART0_RTS/ PPI0_FS3/ACM0_A2/ SMC0_AMS0	J18	Low
4	SPI2FLASH_CS_EN	SPI2 FLASH CS	U11	PC_06/SPI2_SEL1/ SPI2_SS	U44	Low
5	SPI2D2_D3_EN	Enables Quad mode for SPI2 Flash	U12, U13	PC_04/SPI2_D2,PC_05/ SPI2_D3	U44	Low
6	SPDIF_OPTICAL_EN	Enables S/PDIF optical connectors	U17, U18	DAI0_PIN19, DAI0_PIN20	J4, J15	High
7	SPDIF_DIGITAL_EN				U50, U53	Low

Bit	Signal Name	Description	FET	Processor Signal (if applicable)	Component Connected	Default
		Enables S/PDIF digital connectors	U16, U19	DAI0_PIN19, DAI0_PIN20		

The table below shows the output signals of the Microchip GPIO expander (U48), with a TWI address of 0100 010X, where X represents the read or write bit. The signals that control an individual FET have an entry under the **FET** column. The **Component Connected** column shows the board IC that is connected if the FET is enabled. Note that some of the Microchip (U48) output signals are connected directly to components on the board. However, in most cases, the Microchip (U48) is controlling the enable signal of a FET switch. Also note that if a particular functionality of the processor signal is being used, it will be in **bold font** under the **Processor Signal** column.

Output Signals of Microchip GPIO Expander (U48 Port A)

Bit	Signal Name	Description	FET	Processor Signal (if applicable)	Component Connected	Default
0	PUSHBUTTON1_EN	PF_00 is used as GPIO input for push button 1, enabled by default	U23	PF_00 /TM0_TMR6/ SPI1_SEL6	U32	Low
1	PUSHBUTTON2_EN	PF_01 is used as GPIO input for push button 2, enabled by default	U24	PF_01 /TM0_TMR7/ SPI1_SEL7	U33	Low
2	LED10_EN	PE_13 is used as GPIO output for LED10, enabled by default	U20	PE_13 /SPI1_CLK/ PPI0_D20/ SMSC0_AMS1	U6	Low
3	LED11_EN	PE_14 is used as GPIO output for LED11, enabled by default	U21	PE_14 /SPI1_MISO/ PPI0_D21/ SMSC0_ABE0	U6	Low
4	LED12_EN	PE_15 is used as GPIO output for LED12, enabled by default	U22	PE_15 /SPI1_MOSI/ PPI0_D22/ SMSC0_ABE1	U6	Low

3.3 Push Buttons and Switches

This section describes operation of the push buttons and switches.

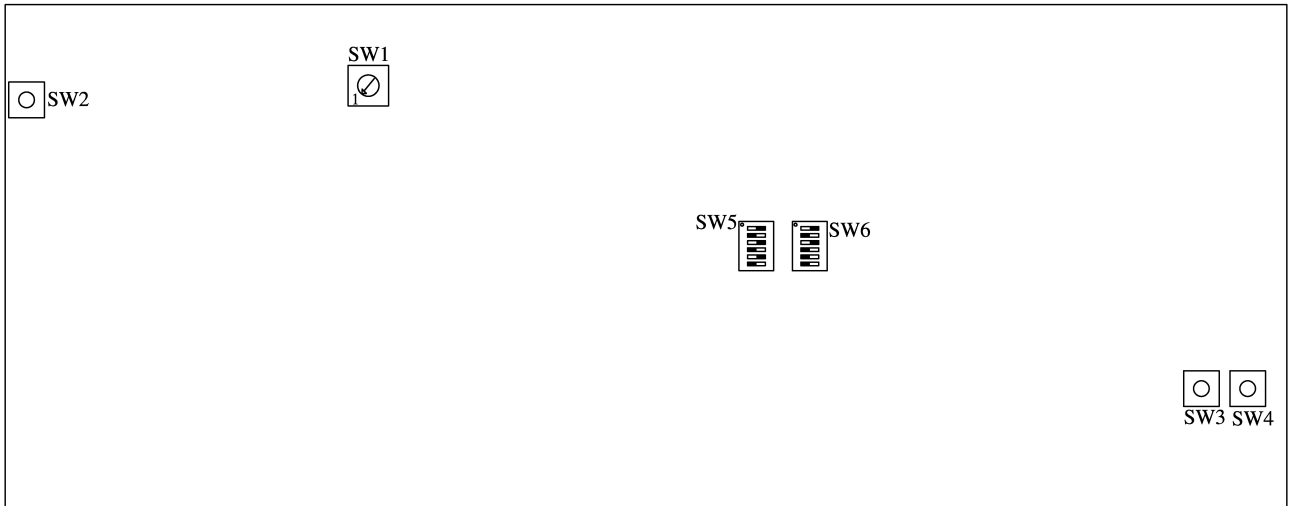

3.3.1 Boot Mode Select Switch (SW1)

The rotary switch (SW1) determines the boot mode of the processor. By default, the ADSP-SC589 processor boots from the SPI flash memory.

SW1 Position	Processor Boot Mode
0	No boot
1	SPI2 master boot. Default boot mode.
2	SPI2 slave boot
6	LP0 slave boot
7	UART0 slave boot

3.3.2 Reset Push Button (SW2)

The reset push button (SW2) resets the following ICs: processor (U1), GPIO extender (U47), GPIO extender (U48), and Ethernet PHY (U51). Also, the reset push button is connected to the expansion interface through the SYS_HWRST signal.

3.3.3 GPIO Push Buttons (SW3–4)

The GPIO push buttons (SW3 and SW4) are connected to the processor's signals PF_01/TM0_TMR7/SPI1_SEL7b and PF_00/TM0_TMR6/SPI1_SEL6b respectively. The signals are connected by default.

3.3.4 JTAG Interface Switches (SW6–7)

The JTAG switches (SW6-7) select between single processor (one board) and multiprocessor (more than one board) configurations. By default, the switches are set up for a single EZ-Board configuration.

Switch Position	Single EZ-Board Use (Default)
SW6.1	ON
SW6.2	OFF
SW6.3	ON
SW6.4	OFF
SW6.5	ON
SW6.6	OFF
SW7.1	ON
SW7.2	OFF
SW7.3	ON
SW7.4	OFF
SW7.5	OFF
SW7.6	OFF

To use an emulator and multiple EZ-Boards simultaneously in one CrossCore Embedded Studio (CCES) session, set up the boards as shown below. Attach the boards to each other through connectors J8 and J9. Connect using the Samtec cables described in .

Switch Position	Main EZ-Board Attached to Emulator	EZ-Board Not Attached to Emulator
SW5.1	ON	OFF
SW5.2	ON	ON

Switch Position	Main EZ-Board Attached to Emulator	EZ-Board Not Attached to Emulator
SW5.3	ON	OFF
SW5.4	ON	ON
SW5.5	ON	OFF
SW5.6	ON	ON
SW6.1	ON	OFF
SW6.2	ON	OFF
SW6.3	ON	OFF
SW6.4	OFF	ON
SW6.5	OFF	ON
SW6.6	ON	OFF

3.4 Jumpers

This section describes functionality of the configuration jumpers.

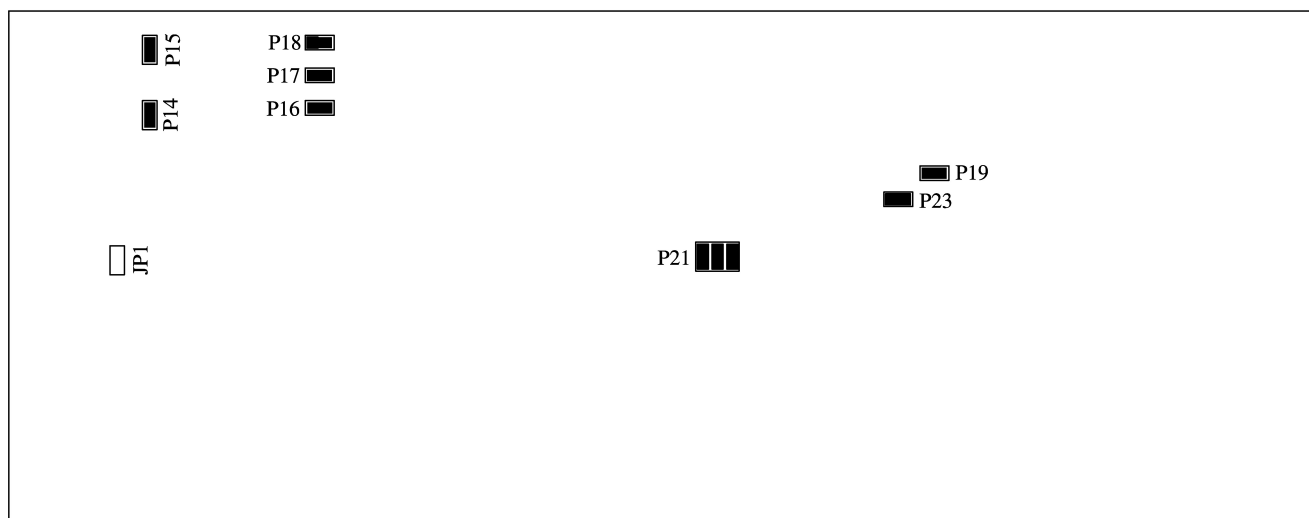

3.4.1 S/PDIF Loopback Jumper (JP1)

The S/PDIF loopback jumper (JP1) is used to connect the S/PDIF input and output signals together and bypass the two RCA connectors.

3.4.2 HADC Jumpers (J21)

The HADC jumper (J21) is used to connect the HADC of the ADSP-SC589 processor to various voltages on the board for monitoring.

Installed Jumper	Voltage
1 & 2	3.3V
3 & 4	1.5V
5 & 6	VDD_INT

3.4.3 Power Jumpers (P14–19, P23)

Remove jumpers listed below to measure the respective voltage across the adjacent sense resistor.

Power Jumper	Resistor
P14	VDD_INT
P15	1.5V
P16	1.8V
P17	3.3V
P18	VDD_EXT
P19	USB0_VBUS
P23	USB1_VBUS

3.5 LEDs

This section describes the on-board LEDs.

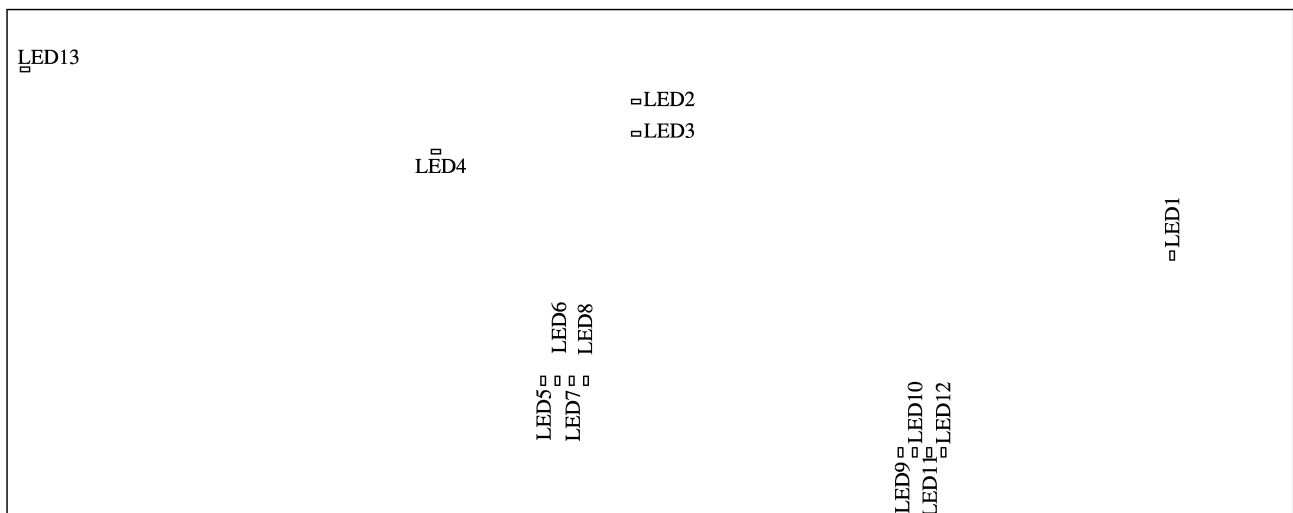

3.5.1 SYS_FAULT LED (LED1)

When SYS_FAULT LED LED1 (red) is ON, it indicates a system fault. For more information, refer to the ADSP-SC58x SHARC+ Processor Hardware Reference.

3.5.2 USB to UART Activity LEDs (LED2–3)

When LED2 is toggling (amber), it indicates that data is being sent from the PC to the EZ-Board. When LED3 is toggling (amber), it indicates that data is being sent from the EZ-Board to the PC.

3.5.3 Ethernet Speed LED (LED4)

The Ethernet speed LED (LED4) is a green LED that shows the connection speed when the Ethernet is enabled for EMAC1. When LED4 is ON, the speed is 100 Mb/s; when LED4 is OFF, the speed is 10 Mb/s.

3.5.4 Ethernet LEDs (LED5–8)

Four LEDs are connected to LED pins of the DP83865 connected on EMAC0. The LEDs are green and illuminated to show the status in Table 2-12.

LED Reference Designator	Status
LED5	Activity
LED6	10M link
LED7	100M link

LED Reference Designator	Status
LED8	1000M link

3.5.5 Power LED (LED9)

When LED9 is ON (green), power is properly supplied to the board.

3.5.6 GPIO LEDs (LED10–12)

Three LEDs are connected to the general-purpose I/O pins of the processor. The LEDs are active high and are ON (amber) by writing a 1 to the correct processor signal.

LED Reference Designator	Processor Programmable Flag Pin
LED10	PE_13
LED11	PE_14
LED12	PE_15

3.5.7 Reset LED (LED13)

When LED13 is ON (red), master reset is active. The reset LED is controlled by the Analog Devices ADM6315 supervisory reset circuit. A master reset is asserted by pressing SW2 which activates LED13. For more information, see Reset Push Button (SW2).

3.6 Connectors

This section describes connector functionality and provides information about mating connectors.

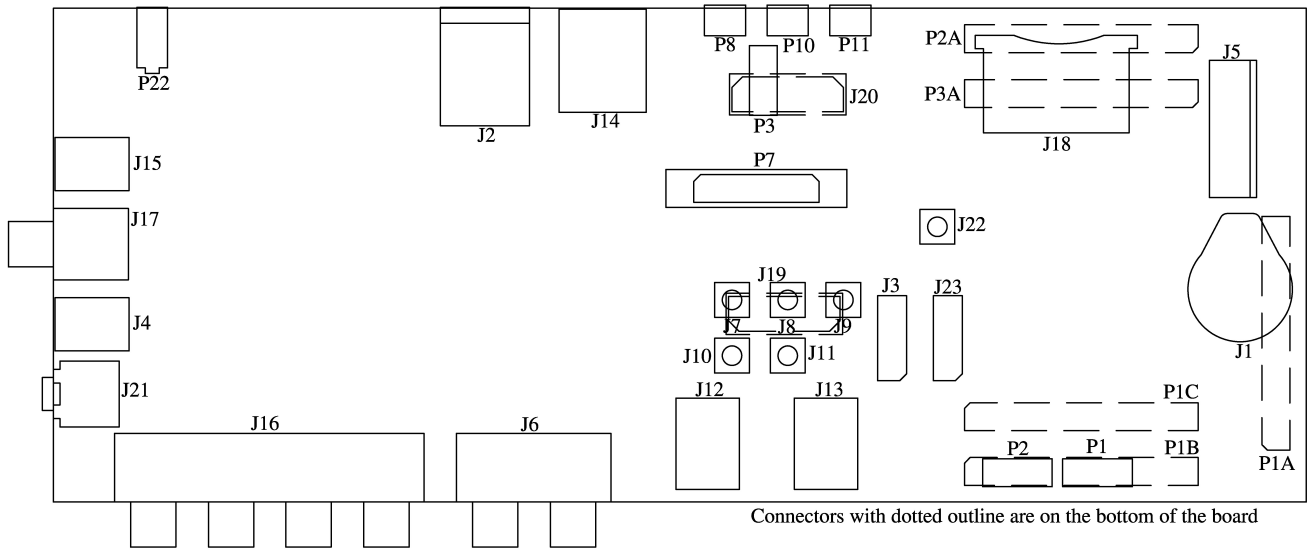

3.6.1 Battery Holder (J1)

The battery holder is not populated on the board. To use the holder, purchase the part listed in the table and solder onto the board.

Part Description	Manufacturer	Part Number
16 mm Coin Cell Battery Holder	Memory Protection Devices	BH600
Battery		
3V Battery	Panasonic	CR1632

3.6.2 Ethernet Connector (J2)

Part Description	Manufacturer	Part Number
RJ45	PULSE ELECTRONICS	J0011D21BNL
Mating Cable		
Standard Ethernet cable		

3.6.3 Link Port_JTAG Connectors (J3, J23)

The link port/JTAG connectors provide access to the link port and JTAG signals of the ADSP-SC589 processor. J3 supports link port 0 and the J23 connector supports link port 1.

Part Description	Manufacturer	Part Number
ERF8 10X2, female	SAMTEC	ERF8-010-05.0-D-DV-L
Mating Cable		
6" coax cable assembly	SAMTEC	ERCD-010-06.00-TED-TEU-1-D

3.6.4 S/PDIF Optical Tx Connector (J4)

Part Description	Manufacturer	Part Number
Fiber optic transmitter	Everlight	PLT133/T10W
Mating Cable		
Standard TOSLINK Optical Digital Cable		

3.6.5 PCIe Connector (J5)

Part Description	Manufacturer	Part Number
PCIe x1	SAMTEC	PCIE-036-02-F-D-TH
Mating Cable		
Standard S/PDIF cable with RCA connectors	SAMTEC	PCIEC-036-0250-EC-EC

3.6.6 Audio Input Output Connector (J6)

Part Description	Manufacturer	Part Number
RCA 2x2 female	Switchcraft	PJRS2X2S
Mating Connector		
Standard audio cable with RCA connectors		

3.6.7 HADC Input Connectors (J7–J11)

Part Description	Manufacturer	Part Number
SMB jack	Emerson	131-3711-201
Mating Connector		
Standard SMB cable		

3.6.8 CAN Connectors (J12–J13)

Part Description	Manufacturer	Part Number
RJ11 vertical	TE Connectivity	5558872-1
Mating Connector		
RJ11 cable		

3.6.9 Ethernet Connector (J14)

Part Description	Manufacturer	Part Number
RJ45 shielded	Assmann	A-2004-2-4-LPS-N-R
Mating Connector		
Standard Ethernet cable		

3.6.10 S/PDIF Optical Rx Connector (J15)

Part Description	Manufacturer	Part Number
Fiber optic receiver	Everlight	PLR135/T10
Mating Cable		
Standard TOSLINK Optical Digital Cable		

3.6.11 Audio Output Connector (J16)

Part Description	Manufacturer	Part Number
RCA 4x2 female	Switchcraft	PJRS4X2U
Mating Connector		
Standard audio cable with RCA connectors		

3.6.12 S/PDIF Digital Connector (J17)

Part Description	Manufacturer	Part Number
RCA 1x2 female	Switchcraft	PJRS1X2S02X
Mating Cable		
Standard S/PDIF cable with RCA connectors		

3.6.13 SD Connector (J18)

Part Description	Manufacturer	Part Number
SD 8-bit, 2 GB	SANDISK	MHC-W21-601
Mating Connector		
2 GB	SANDISK	SDSDB-2048-A11

3.6.14 ADC Connector (J19)

This is not populated.

Part Description	Manufacturer	Part Number
40-pin high speed socket	SAMTEC	QSH-020-01-L-D-DP-A
Mating Connector		

Part Description	Manufacturer	Part Number
40-pin high speed header	SAMTEC	QTH-0202-01-L-D-DP-A

3.6.15 MLB Connector (J20)

Part Description	Manufacturer	Part Number
40-pin high speed socket	SAMTEC	QSH-020-01-L-D-DP-A
Mating Connector		
40-pin high speed header	SAMTEC	QTH-0202-01-L-D-DP-A

3.6.16 Headphone Connector (J21)

Part Description	Manufacturer	Part Number
3.5mm headphone connector	CUI	SJ1-3525NG
Mating Cable		
Standard audio cable with 3.5mm connector		

3.6.17 CLKIN0 Connector (J22)

Part Description	Manufacturer	Part Number
SMB jack	Emerson	131-3711-201
Mating Cable		
Standard SMB cable		

3.6.18 TWI0_SPI2 Connector (P1)

Use P1 to connect with TWI0 and SPI2 signals for external use. The connector is a 0.1" header. The pinout can be found in [Appendix B - Schematics](#).

3.6.19 SigmaStudio Connector (P2)

This connector interfaces with SigmaStudio through the EVAL-ADUSB2EBZ board. The connector is a 0.1" header. The pinout can be found in [Appendix B - Schematics](#).

3.6.20 JTAG Connector (P3)

The JTAG header (P3) provides debug connectivity for the processor. This is a 0.05" shrouded through-hole connector from SAMTEC (SHF-105-01-L-D-SM-K). This connector mates with ICE-1000, ICE-2000, and any newer Analog Devices emulators. For more information, see [Debug Interface](#).

3.6.21 TRACE and JTAG Connector (P7)

The TRACE and JTAG connector (P7) provides connectivity to the processor's trace interface. This is a MICTOR connector from TYCO (2-5767004-2). At this time, there are no trace pods available.

3.6.22 USB to UART Connector (P8)

Part Description	Manufacturer	Part Number
USB Micro-AB	Hirose	ZX62D-AB-5P8
Mating Cable		
USB Micro-B to Standard-A cable		

3.6.23 USB Connectors (P10–P11)

Part Description	Manufacturer	Part Number
USB Micro-AB	Hirose	ZX62D-AB-5P8
Mating Cable		
USB Micro-B to Standard-A or Micro-A to Standard-A receptacle cable		

3.6.24 Power Connector (P22)

Part Description	Manufacturer	Part Number
0.65 mm power jack	CUI	045-0883R
Mating Cable		
5.0VDC@3.6A power supply	GLOBETEK	GS-1750(R)

3.6.25 Expansion Interface III Connectors (P1A–C, P2A, P3A)

Five board-to-board connectors provide signals from the SPI, TWI, UART, SPORT, and GPIO interfaces of the processor. The connectors are located on the bottom side of the board.

For more information, see [Expansion Interface](#).

Part Description	Manufacturer	Part Number
120-pin, 0.6 mm	Hirose	FX8-120P-SV1(91)
Mating Cable		
120-pin, 0.6 mm	Hirose	FX8-120S-SV(21)

4 Appendix A - Bill of Materials

The bill of materials corresponds to [Appendix B - Schematics](#).

[Edit Document](#)

Qty	Description	Reference Designator	Manufacturer	Part Number
1	74LVC14A SOIC14	U32	TI	74LVC14AD
1	IDT74FCT3244APY SSOP20	U6	IDT (R)	IDT74FCT3244APYG
4	SN74LVC1G08 SOT23- 5	U53-U55,U74	TI (R)	SN74LVC1G08DBVE
1	SN65LVDS2D SOIC8	U50	NATIONAL S (R)	DS90LV018ATM
3	SN74CB3Q3245 TSSOP20	U27-U29	DIGI-KEY (R)	296-19130-1-ND
2	MIC2025-1 SOIC8	U52,U60	DIGI-KEY (R)	576-1057-ND
2	74CBTLV3244 TSSOP20	U4,U5	IDT (R)	IDT74CBTLV3244PGG
2	25MHZ OSC013	Y1,Y2	DIGI-KEY (R)	535-9140-1-ND
1	24MHZ OSC013	Y3	DIGI-KEY (R)	535-9138-2-ND
1	DP83848 LQFP48	U51	NATIONAL S (R)	DP83848CVV/NOPB
22	74CBTLV1G125 SC70_5	U9-U24,U58,U59,U61,U66,U70,U71	TI (R)	SN74CBTLV1G125DCKR
2	MCP23017 QFN65P600X600-29N	U47,U48	DIGI-KEY (R)	MCP23017-E/ML-ND

1	PI3C3125 TSSOP14	U26	PERICOM (R)	PI3C3125
1	25MHZ OSCCC200X250	U64	DIGI-KEY (R)	478-4780-1-ND
1	32.768KHZ OSC_ABS07L	Y4	DIGI-KEY (R)	535-9542-2-ND
1	FT232RQ QFN50P500X500-33NA	U7	DIGI-KEY (R)	768-1008-1-ND
1	INA3221 QFN65P400X400-17N	U57	DIGI-KEY (R)	296-30459-1-ND
1	24MHZ OSCCC200X250	U62	DIGI-KEY (R)	478-4778-1-ND
1	ADM8828ARTZ SOT95P280-6N	U67	ADI (R)	ADM8828ARTZ
1	FZT953 SOT-223	VR2	DIGI-KEY (R)	FZT953CT-ND
2	MT41K128M16JT FBGA96	U2,U3	MICRON (R)	MT41K128M16JT-125:K
1	TJA1145T SOIC14	U43	NXP (PHILI (R)	TJA1145T
1	TJA1055/3 SOIC14	U33	NXP (PHILI (R)	TJA1055/3
1	DP83865 PQFP128	U46	TI (R)	DP83865DVH/NOPB
1	H5007 SMT	U30	DIGI-KEY (R)	553-1535-1-ND
1	SI4204 SOIC8	U56	VISHAY (R)	SI4204DY-T1-GE3
1	ADP5054 LFCSP48	VR3	ADI (R)	ADP5054ACPZ-R7
1	SI52112-BE VFDFN10	U31	DIGI-KEY (R)	336-2451-ND

1	CS2100-CP MSOP10	U49	DIGI-KEY (R)	598-1750-ND
1	SI5356A QFN24	U25	SILICON LA (R)	Si5356A-B03215-GM
3	25MHZ SMT	Y5-Y7	ECS INC. (R)	ECS-250-20-3X-TR
1	ADP2164-3.3 LFCSP16	U65	ADI (R)	ADP2164ACPZ-3.3-R7
1	50MHZ SMT	U63	DIGI-KEY (R)	478-6302-1-ND
1	SC589 W25Q128FV U44	U44	WINBOND (R)	W25Q128FVSIG
1	SC589 25LC010A U40	U40	MICROCHIP (R)	25LC010AT-I/OT
1	AD8532ARZ SOIC8	U35	ADI (R)	AD8532ARZ
1	AD797BRZ SOIC8	U68	ADI (R)	AD797BRZ
4	AD8606ARZ SOIC8	U36-U39	ADI (R)	AD8606ARZ
1	ADG774ABRQZ QSOP16	U41	ADI (R)	ADG774ABRQZ
1	AD8022 MSOP8	U34	ADI (R)	AD8022ARMZ
1	ADP121-AUJZ25 TSOT5	VR1	ADI (R)	ADP121-AUJZ25R7
1	ADP1613 MSOP8	VR4	ADI (R)	ADP1613ARMZ-R7
1	ADM6315 SOT143	U45	ADI (R)	ADM6315-29D2ARTZR7
1	ADAU1979WBCPZ LFCSP40	U42	ADI (R)	ADAU1979WBCPZ
1	ADSP-SC589 BGA529	U1	ADI	ADSP-SC589-ENG

1	ADM6315-29D3 SOT143	U69	ADI	ADM6315-29D3ARTZR7
1	RCA 4X2 CON011	J16	SWITCHCRAF (R)	PJRS4X2U01X
1	RCA 2X2 CON013	J6	SWITCHCRAF (R)	PJRS2X2S01X
1	MICTOR 38PIN CON015	P7	TYCO ELECT (R)	2-5767004-2
2	DIP6 SWT017	SW5,SW6	CTS (R)	218-6LPST
1	IDC 3X2 IDC3X2_SMT	P21	SAMTEC (R)	TSM-103-01-T-DV
1	RCA 1X2 CON031	J17	SWITCHCRAF (R)	PJRS1X2S02X
2	RJ11 4PIN CON039	J12,J13	TYCO ELECT (R)	5558872-1
7	IDC 2X1 IDC2X1	P14-P19,P23	SAMTEC (R)	HTSW-102-07-T-S
1	3A RESETABLE FUS004	F1	TYCO ELECT (R)	SMD300F-2
10	IDC 2PIN_JUMPER_SHORT	SJ1-SJ9,SJ11	DIGI-KEY (R)	S9001-ND
1	3.5MM STEREO_JACK CON_CUI_SJ1-3525NG	J21	DIGI-KEY (R)	CP1-3525NG-ND
1	PWR .65MM CON045	P22	DIGI-KEY (R)	CP1-023-ND
1	IDC 2X1 IDC2X1_SMT	JP1	SAMTEC (R)	TSM-102-01-T-SV
1	ROTARY SWT027	SW1	COPAL ELEC (R)	S-8110

1	RJ45 W/LEDS CON065	J2	PULSE ENG. (R)	J0011D21BNL
1	SD_CONN 8-BIT CON067	J18	MORETHANAL (R)	MHC-W21-601-LF
5	0.6MM 120PIN HIROSE_FX8-120P-SV1 (91)	P1A-P3A,P1B,P1C	HIROSE (R)	FX8-120P-SV1(91)
1	TEST LOOP LOOP_2838	GP1	KEYSTONE (R)	5016
2	IDC 5X2 TSM-105-01-T- DV	P1,P2	SAMTEC (R)	TSM-105-01-T-DV
3	USB-MICRO 5PIN HIROSE_ZX62D-AB- 5P8	P8,P10,P11	DIGI-KEY (R)	H11494CT-ND
1	0.05 10PIN SAMTEC_SHF-105-01- L-D-SM-K	P3	SAMTEC (R)	SHF-105-01-L-D-SM-K- TR
1	FIBER-OPTIC SPDIF EVERLIGHT_PLT133 /T10	J4	DIGI-KEY (R)	1080-1430-ND
1	FIBER-OPTIC SPDIF EVERLIGHT_PLR135 /T10	J15	DIGI-KEY (R)	1080-1433-ND
6	SMB 1PIN SMT	J7-J11,J22	EMERSON	131-3711-201
1	PCIe 36PIN SMT	J5	SAMTEC (R)	PCIE-036-02-F-D-TH
1	QSH 40PIN SMT	J19	SAMTEC (R)	QSH-020-01-L-D-DP-A
1	QSH 40PIN SMT	J20	SAMTEC (R)	QSH-020-01-L-D-DP-A

1	RJ45 8PIN TH	J14	DIGI-KEY (R)	AE10387-ND
2	ERF8 10X2 SMT	J3,J23	SAMTEC (R)	ERF8-010-05.0-S-DV-L-TR
3	MOMENTARY SW_ADTSMW64	SW2-SW4	DIGI-KEY	679-2310-2-ND
2	0.22UF 25V 10% 0805 X7R	C152,C153	AVX CORPOR (R)	08053C224KAT2A
5	600 200MA 0603	FER6-FER9,FER17	DIGI-KEY (R)	490-1014-2-ND
9	600 500MA 1206	FER3-FER5,FER10-FER13,FER18, FER19	LAIRD TECH	HZ1206B601R-10
6	1UF 16V 10% 0805 X7R	C118,C216,C217,C299,C300,C344	DIGI-KEY (R)	399-1284-2-ND
12	10UF 16V 20% CAP002 ELEC	CT1-CT12	PANASONIC (R)	EEE1CA100SR
2	68UF 25V 20% CAP003	CT13,CT14	PANASONIC (R)	EEE-FC1E680P
2	0 1/8W 5% 0805	R323,R325	VISHAY (R)	CRCW08050000Z0EA
1	0 1/8W 5% 0805	R267	VISHAY (R)	CRCW08050000Z0EA
1	190 5A FER002	FER14	MURATA (R)	DLW5BSN191SQ2
12	10UF 6.3V 10% 0805 X5R	C41,C151,C162,C169,C180,C187, C233,C249,C265,C301-C303	AVX CORPOR (R)	08056D106KAT2A
1	0.1UF 10V 10% 0402 X5R	C311	AVX CORPOR (R)	0402ZD104KAT2A
78	0.1UF 10V 10% 0402 X5R		AVX CORPOR (R)	0402ZD104KAT2A

		C1-C4,C23,C24,C30,C68-C70,C72, C73,C79,C90,C92,C94,C96,C98, C100,C102,C108,C110,C112-C115, C124,C126,C134,C136,C138,C154, C176-C179,C195-C198,C223,C224, C229,C234-C238,C243,C247,C250- C254,C259,C263,C266-C270,C275, C279,C312,C313,C336-C341,C345, C348,C352,C353,C3		
122	0.01UF 16V 10% 0402 X7R	C5-C21,C31-C33,C35,C39,C40,C42- C44,C55-C57,C65-C67,C74,C75, C80-C85,C131,C157-C161,C211, C212,C214,C218-C222,C225-C228, C230-C232,C239-C242,C244-C246, C248,C255-C258,C260-C262,C264, C271-C274,C276-C278,C280-C287, C290-C295,C304-C307,C310,C314, C331-C335,C342,C34	AVX CORPOR (R)	0402YC103KAT2A
34	10K 1/16W 5% 0402	R4,R39,R43,R44,R142,R143,R208, R213-R217,R292,R303,R304,R307, R308,R310,R313,R342,R354,R356, R371-R376,R409-R411,R419,R421, R435	VISHAY (R)	CRCW040210K0FKED
99	10K 1/16W 5% 0402	R1-R3,R5-R17,R37,R38,R40,R42, R46,R51,R55,R58,R103-R105,R134, R135,R146,R147,R182,R183,R185, R189,R191,R193,R209,R212,R243- R248,R250-R254,R256-R259,R263, R264,R266,R293-R300,R305,R306, R309,R311,R312,R314,R317-R319, R321,R327-R329,R338-R341,R343- R346,R350,R353,	VISHAY (R)	CRCW040210K0FKED
29	0 1/10W 5% 0402	R47-R49,R53,R62,R66,R68,R70, R72,R144,R148,R197,R201,R210, R351,R379-R384,R390,R392-R395, R430,R434,R437	PANASONIC (R)	ERJ-2GE0R00X

16	0 1/10W 5% 0402	R145,R149,R196,R200,R315,R316, R320,R322,R357,R358,R391,R403, R417,R418,R424,R425	PANASONIC (R)	ERJ-2GE0R00X
1	22 1/10W 5% 0402	R139	DIGI-KEY (R)	P22JTR-ND
19	33 1/16W 5% 0402	R50,R52,R54,R56,R60,R61,R255, R262,R349,R377,R378,R385,R388, R389,R396,R404-R407	VISHAY (R)	CRCW040233R0JNED
2	150UF 10V 10% D TANT-LOW-ESR	CT22,CT23	DIGI-KEY (R)	478-3321-2-ND
3	107.0 1/10W 1% 0805	R141,R347,R348	DIGI-KEY (R)	311-107CRTR-ND
1	249.0 1/10W 1% 0805	R140	DIGI-KEY (R)	311-249CRTR-ND
1	1UF 16V 10% 0603 X5R	C34	DIGI-KEY (R)	399-5090-2-ND
2	4.7UF 25V 20% 0805 X5R	C213,C215	AVX CORPOR (R)	0805ZD475KAT2A
1	4.7UF 6.3V 20% 0603 X5R	C48	AVX CORPOR (R)	06036D475MAT2A
1	10M 1/10W 5% 0603	R45	VISHAY (R)	CRCW060310M0FNEA
3	1M 1/10W 5% 0603	R63,R324,R326	VISHAY (R)	CRCW06031M00JNEA
1	10.0K 1/16W 1% 0603	R138	VISHAY/DAL (R)	CRCW060310K0FKEA
1	6800PF 50V 10% 0603 X7R	C327	DIGI-KEY (R)	311-1084-2-ND
8	237.0 1/10W 1% 0603	R152,R155,R161,R164,R168,R171, R176,R179	DIGI-KEY (R)	311-237HRTR-ND

4	750.0K 1/10W 1% 0603	R154,R163,R170,R178	DIGI-KEY (R)	311-750KHRTR-ND
4	11.0K 1/10W 1% 0603	R150,R158,R166,R174	DIGI-KEY (R)	311-11.0KHRTR-ND
8	5.49K 1/10W 1% 0603	R153,R156,R159,R162,R169,R172, R177,R180	DIGI-KEY (R)	311-5.49KHRTR-ND
2	49.9K 1/10W 1% 0603	R132,R133	DIGI-KEY (R)	311-49.9KHRTR-ND
9	5.76K 1/10W 1% 0603	R151,R157,R160,R165,R167,R173, R175,R181,R397	DIGI-KEY (R)	311-5.76KHRTR-ND
8	100PF 50V 5% 0603 NPO	C163,C167,C170,C175,C181,C185, C188,C192	AVX CORPOR (R)	06035A101JAT2A
8	1000PF 50V 5% 0603 X7R	C165,C166,C172,C174,C183,C184, C190,C191	DIGI-KEY (R)	399-1083-2-ND
3	2.21K 1/10W 1% 0603	R273,R276,R290	DIGI-KEY (R)	311-2.21KHRTR-ND
8	680PF 50V 5% 0603 NPO	C164,C168,C171,C173,C182,C186, C189,C193	MURATA (R)	GRM1885C1H681JA01D
5	75.0 1/10W 1% 0603	R79-R81,R96,R137	VISHAY/DAL (R)	CRCW060375R0FKEA
6	1UF 6.3V 20% 0402 X5R	C199,C200,C288,C289,C308,C309	MURATA (R)	GRM155R60J105ME19D
2	100 1/16W 5% 0402	R260,R261	DIGI-KEY (R)	311-100JRTR-ND
1	390PF 25V 5% 0603 NPO	C117	AVX CORPOR (R)	06033A391FAT2A
1	5600PF 16V 5% 0805 NPO	C116	AVX CORPOR (R)	0805YA562JAT2A
1	15.0K 1/16W 1% 0603	R136	DIGI-KEY (R)	311-15.0KHRTR-ND

13	10UF 10V 10% 0805 X5R	C71,C109,C111,C123,C125,C127- C130,C135,C137,C324,C346	MURATA (R)	GRM21BR61A106KE19L
7	0.051 1/2W 1% 1206	R203-R207,R211,R352	SEI (R)	CSF 1/2 0.05 1%R
1	10UF 16V 10% 1210 X5R	C206	AVX CORPOR (R)	1210YD106KAT2A
2	1000PF 50V 5% 1206	C194,C210	AVX CORPOR (R)	12065A102JAT2A
2	0.022UF 25V 10% 0402 X7R	C63,C64	DIGI-KEY (R)	490-3252-1-ND
1	5A MBRS540T3G SMC	D11	ON SEMICON (R)	MBRS540T3G
2	VARISTOR V5.5MLA 30A 0603	R18,R19	LITTELFUSE (R)	V5.5MLA0603
2	PTC 0.5A 1206	R301,R302	LITTELFUSE (R)	1206L050-C
1	20MA MA3X717E DIO005	D3	DIODES INC (R)	BAS70-05-7-F
8	330.0 1/16W 1% 0402	R36,R64,R65,R240-R242,R249, R265	DIGI-KEY (R)	541-330LCT-ND
2	3.01K 1/16W 1% 0402	R59,R416	Rohm Semiconduc	MCR01MRTF3011
10	1.0K 1/16W 1% 0402	R20-R23,R78,R99,R107,R359,R426, R427	PANASONIC (R)	ERJ-2RKF1001X
1	10.0 1/10W 1% 0603	R97	DIGI-KEY (R)	311-10.0HRTR-ND
6	10.0K 1/16W 1% 0402	R67,R71,R84,R199,R422,R423	DIGI-KEY (R)	541-10.0KLCT-ND

3	1.50K 1/16W 1% 0402	R41,R57,R291	PANASONIC (R)	ERJ-2RKF1501X
2	680 1/16W 1% 0402	R76,R77	BC COMPONE (R)	2312 275 16801
11	100K 1/16W 5% 0402	R100-R102,R330-R337	DIGI-KEY (R)	541-100KJTR-ND
2	100K 1/16W 5% 0402	R88,R366	DIGI-KEY (R)	541-100KJTR-ND
1	1.0 1/16W 1% 0402	R398	DIGI-KEY (R)	541-1.00LCT-ND
2	22UF 16V 10% 1210 X5R	C60,C329	TAIYO YUDE (R)	EMK325BJ226KM-T
8	18PF 50V 5% 0402 NP0	C28,C29,C36-C38,C296,C322,C323	Murata	GRM1555C1H180JA01D
1	33 1/16W 5% RNS003	RN17	PANASONIC (R)	EXB-2HV330JV
14	33 1/32W 5% RNS005	RN1-RN6,RN8-RN13,RN15,RN16	PANASONIC (R)	EXB-28V330JX
2	0.01UF 25V 10% 0402 X7R	C46,C50	DIGI-KEY (R)	399-1278-1-ND
3	100.0 1/16W 1% 0402	R28,R29,R362	DIGI-KEY (R)	541-100LCT-ND
1	1000PF 50V 5% 0402 NPO	C76	DIGI-KEY (R)	490-3244-1-ND
2	100PF 50V 5% 0402 COG	C297,C298	MURATA	GCM1555C1H101JA16D
1	30A GSOT05 SOT23-3	D4	VISHAY (R)	GSOT05-E3-08
2	165.0 1/10W 1% 0603	R269,R275	DIGI-KEY (R)	P165HTR-ND
1	220.0 1/10W 1% 0603	R277	DIGI-KEY (R)	P220HTR-ND

1	4.87K 1/10W 1% 0603	R274	DIGI-KEY (R)	541-4.87KHCT-ND
9	2.2K 1/10W 5% 0402	R30-R35,R412-R414	PANASONIC (R)	ERJ-2GEJ222X
6	GREEN LED_0603	LED4-LED9	DIGI-KEY (R)	475-1409-2-ND
2	4700PF 2A FIL_NFE61PT	FER15,FER16	DIGI-KEY (R)	490-2554-2-ND
4	10UF 16V 10% 0805 X5R	C201,C203,C205,C208	DIGI-KEY (R)	490-3886-2-ND
2	60.4 1/10W 1% 0402	R367,R368	PANASONIC	ERJ-2RKF60R4X
35	49.9 1/16W 1% 0402	R218-R239,R268,R270-R272,R282- R289,R408	STACKPOLE (R)	RMCF0402FT49R9
13	2.0K 1/10W 1% 0402	R82,R85,R87,R89-R95,R415,R428, R429	PANASONIC (R)	ERJ-2RKF2001X
1	2.0K 1/10W 1% 0402	R86	PANASONIC (R)	ERJ-2RKF2001X
5	0.1UF 16V 10% 0402 X7R	C45,C47,C49,C155,C156	DIGI-KEY (R)	587-1451-2-ND
3	15KV ESD7004 DFN50P250X100-10N	D8-D10	ON SEMICON (R)	ESD7004MUTAG
1	15KV ESDA6V1SC SOT95P280-6N	D5	DIGI-KEY (R)	497-6637-1-ND
2	60.4K 1/10W 1% 0603	R74,R75	DIGI-KEY (R)	311-60.4KHRTR-ND
2	22UF 6.3V 20% 0805 X5R	C104,C105	DIGI-KEY	445-1422-2-ND
1		C325	TDK (R)	C3216X7R1C475K/1.60

	4.7UF 16V 10% 1206 X7R ZZZ			
1	32.4K 1/10W 1% 0402	R184	PANASONIC (R)	ERJ-2RKF3242X
1	562.0 1/16W 1% 0402	R106	DIGI-KEY (R)	541-562LTR-ND
1	390PF 50V 5% 0402 NP0	C132	TDK (R)	C1005C0G1H391J
5	10PF 50V 5% 0402 NP0	C51-C54,C326	DIGI-KEY (R)	399-1011-2-ND
1	93.1K 1/16W 1% 0402	R399	DIGI-KEY (R)	541-93.1KLTR-ND
2	RED LED_0603	LED1,LED13	DIGI-KEY (R)	475-2512-2-ND
5	YELLOW LED_0603	LED2,LED3,LED10-LED12	DIGI-KEY (R)	475-2558-1-ND
2	10UF 6.3V 20% 0603 X5R	C22,C25	MURATA	GRM188R60J106ME47D
12	475 1/8W 1% 0805	R108,R110,R112,R114,R116,R118, R120,R122,R124,R126,R128,R130	PANASONIC (R)	ERJ-6ENF4750V
2	150PF 50V 5% 0402 NPO	C61,C62	DIGI-KEY (R)	490-3229-2-ND
3	10 1/10W 1% 0402	R69,R73,R401	PANASONIC (R)	ERJ-2RKF10R0X
4	4700PF 50V 10% 0402 X7R	C59,C202,C204,C207	DIGI-KEY (R)	399-3072-2-ND
12	49.9K 1/16W 1% 0402	R109,R111,R113,R115,R117,R119, R121,R123,R125,R127,R129,R131	DIGI-KEY (R)	541-49.9KLTR-ND
3	10UF 6.3V 20% 0402 X5R	C87-C89	DIGI-KEY (R)	445-8920-1-ND

2	0.1UF 35V 10% 0402 X7R	C58,C328	DIGI-KEY (R)	445-6901-2-ND
10	0.01UF 50V 10% 0402 X7R	C86,C91,C93,C95,C97,C99,C101, C103,C106,C107	DIGI-KEY (R)	490-4762-2-ND
1	5600PF 25V 10% 0402 X7R	C133	DIGI-KEY (R)	490-5420-2-ND
12	2700PF 50V 5% 0805 COG	C139-C150	DIGI-KEY (R)	445-7508-2-ND
1	200.0 1/10W 1% 0402	R365	PANASONIC (R)	ERJ-2RKF2000X
2	39PF 50V 5% 0402 NP0	C77,C78	DIGI-KEY (R)	1276-1016-1-ND
1	18 1/10W 1% 0603	R98	PANASONIC (R)	ERJ-3EKF18R0V
4	0.47UF 50V 10% 0603 X5R	C119-C122	DIGI-KEY (R)	587-3171-2-ND
1	10.7K 1/16W 1% 0402	R400	DIGI-KEY (R)	541-10.7KLTR-ND
1	3.74K 1/16W 1% 0402	R186	PANASONIC (R)	ERJ-2RKF3741X
2	619 1/10W 1% 0402	R360,R361	PANASONIC (R)	ERJ-2RKF6190X
2	15KV ESDA5V3SC6 SOT95P280X145-6N	D6,D7	DIGI-KEY (R)	497-6633-1-ND
2	34 1/10W 1% 0402	R26,R27	PANASONIC (R)	ERJ-2RKF34R0X
2	240 1/10W 1% 0402	R24,R25	PANASONIC (R)	ERJ-2RKF2400X

1	3000PF 50V 5% 0603 NP0	C209	DIGI-KEY (R)	490-6384-2-ND
9	47UF 6.3V 20% 0805 X5R	C315-C321,C330,C347	DIGI-KEY	587-1779-2-ND
2	3A PESD1CAN SMT	D1,D2	NXP (PHILI (R)	PESD1CAN
2	510 .2A SMT	FER1,FER2	DIGI-KEY (R)	445-3958-2-ND
1	4.7UH 20% SMT	L5	COILCRAFT	XAL4030-472MEC
1	3.3UH 20% SMT	L6	COILCRAFT	XAL4030-332MEC
1	2.2UH 20% SMT	L4	COILCRAFT	XAL5030-222MEC
2	105.0 1/16W 1% 0402	R363,R364	VISHAY (R)	CRCW0402105RFKED
4	324.0 1/16W 1% 0402	R278-R281	DIGI-KEY (R)	541-324LTR-ND
1	9.76K 1/10W 1% 0402	R83	PANASONIC (R)	ERJ-2RKF9761X
1	32.4K 1/10W 1% 0402	R202	DIGI-KEY	P32.4KLTR-ND
1	31.6K 1/10W 1% 0402	R194	PANASONIC (R)	ERJ-2RKF3162X
2	22K 1/10W 1% 0402	R187,R188	PANASONIC (R)	ERJ-2RKF2202X
1	12.4K 1/10W 1% 0402	R192	PANASONIC (R)	ERJ-2RKF1242X
1	8.66K 1/10W 1% 0402	R190	PANASONIC (R)	ERJ-2RKF8661X
1	5.1K 1/10W 1% 0402	R198	PANASONIC (R)	ERJ-2RKF5101X

1	4.3K 1/10W 1% 0402	R195	PANASONIC (R)	ERJ-2RKF4301X
1	1A PD3S130L POWERDI323	D12	DIODES INC (R)	PD3S130L-7
1	1.0UH 20% SMT	L8	COILCRAFT (R)	XAL4020-102MEB
1	8.2UH 20% SMT	L7	COILCRAFT (R)	XAL4040-822MEB
1	1.0UH 20% SMT	L3	COILCRAFT (R)	XAL5030-102ME

5 Appendix B - Schematics



Please see the PDF that accompanies the Board Support Package for the full schematic.



Стандарт Электрон Связь

Мы молодая и активно развивающаяся компания в области поставок электронных компонентов. Мы поставляем электронные компоненты отечественного и импортного производства напрямую от производителей и с крупнейших складов мира.

Благодаря сотрудничеству с мировыми поставщиками мы осуществляем комплексные и плановые поставки широчайшего спектра электронных компонентов.

Собственная эффективная логистика и склад в обеспечивает надежную поставку продукции в точно указанные сроки по всей России.

Мы осуществляем техническую поддержку нашим клиентам и предпродажную проверку качества продукции. На все поставляемые продукты мы предоставляем гарантию .

Осуществляем поставки продукции под контролем ВП МО РФ на предприятия военно-промышленного комплекса России , а также работаем в рамках 275 ФЗ с открытием отдельных счетов в уполномоченном банке. Система менеджмента качества компании соответствует требованиям ГОСТ ISO 9001.

Минимальные сроки поставки, гибкие цены, неограниченный ассортимент и индивидуальный подход к клиентам являются основой для выстраивания долгосрочного и эффективного сотрудничества с предприятиями радиоэлектронной промышленности, предприятиями ВПК и научно-исследовательскими институтами России.

С нами вы становитесь еще успешнее!

Наши контакты:

Телефон: +7 812 627 14 35

Электронная почта: sales@st-electron.ru

Адрес: 198099, Санкт-Петербург,
Промышленная ул, дом № 19, литера Н,
помещение 100-Н Офис 331