

FLEX-BX200

2U AI Modular PC with 8th Generation LGA1151 Core™ i7/i5/i3 and Pentium® Processor

NEW



Hardware Feature

- 2U AI Modular PC with 8th Generation LGA 1151 Intel® Core™ i7/i5/i3 and Pentium® processor
- Four hot-swappable and accessible HDD drive bays, support RAID 0/1/5/10
- Two PCIe 3.0 by 4 and two PCIe 3.0 by 8 slots
- Dual M.2 2280 PCIe Gen 3.0 x4 NVMe™ SSD support
- QTS-Gateway support

Specifications

| Model | | FLEX-BX200-Q370 |
|------------------------|-------------------------|---|
| System | CPU | 8th Generation Intel® Core™ i7/i5/i3 processors in the LGA 1151 package (Please choose the TDP of the the processor under 65W) |
| | Chipset | Intel® 300 Series Chipsets Q370 (Coffee Lake) |
| | Memory | 2 x 288-pin 2666/2400 MHz dual-channel DDR4 unbuffered DIMM supporting up to 64GB |
| | Graphics Engine | Intel® HD Graphics Gen 9 Engines with Low power 16 execution unit, supports DX2015, OpenGL 5.X and OpenCL2.x, ES 2.0 |
| | Ethernet | Intel® I211 controller |
| Storage | | 4 x accessible 2.5" HDD/SSD SATA 6 Gb/s bay (with RAID 0/1/5/10 support) with LED indicator 2 x NGFF M.2(2280) M Key socket (support NVMe SSD) |
| I/O Ports and Switches | | 1 x HDMI output 2 x GbE LAN 6 x USB 3.1 Gen 1 (5Gb/s) Type-A 2 x RS-232 DB-9 type 1 x Mic in/1 x Line out 1 x AC Inlet Power button with power LED (power on=Blue) AT/ATX mode switch Reset button |
| Expansion Slots | | 2 x PCIe 3.0 by 8 (by 16 slot) 2 x PCIe 3.0 by 4 (Maximum card size supported: 68 mm x 167 mm) |
| Thermal Solution | | System Fan x3, CPU Cooler x1 |
| Power supply | | AC input ATX power supply 1. 250W power supply - Input: 115VAC~230VAC, 50/60Hz - Output (Max.): 3.3V@12A, 5V@14A, 12V@25A, -12V@0.3A, +5Vsb@3A 2. 350W power supply (Build to Order) - Input: 115VAC~264VAC, 50/60Hz - Output (Max.): 3.3V@14A, 5V@16A, 12V@29A, -12V@0.3A, +5Vsb@3A -Efficiency: Full load (100%) 87%, Typical load (50%) 90%, Light load (20%) 87% |
| Watchdog Timer | | Software Programmable support 1~255 sec. System reset |
| Construction | Chassis Construction | Metal Housing |
| | Mounting | Wall and Rack Mount |
| | Color | Black |
| | Dimensions (LxDxH) (mm) | 357 x 230 x 88 |
| | Weight (kg) Net/Gross | 4/6 |
| Environmental | Operating Temperature | -20°C ~ 50°C (with SSD and TDP 65W processor) -20°C ~ 40°C (with HDD or add-on cards without fan) |
| | Storage Temperature | -20°C ~ 60°C |
| | Operating Humidity | 5% ~95%, non-condensing |
| | Vibration | 5~17Hz, 0.1 double amplitude displacement 17~640Hz 1.5G acceleration peak to peak |
| | shock | 10G acceleration part to part (11ms) |

Ordering Information

| Part No. | Description |
|----------------------------|---|
| FLEX-BX200-Q370-P/25-R10 | 2U AI Modular Box PC, Intel® Pentium® Gold G5400T Processor (2-core, 4-thread, 3.10 GHz) TDP 35W, two PCIe x4 and two PCIe x8 slots, four HDD bays, 250W PSU, R10 |
| FLEX-BX200-Q370-i3/25-R10 | 2U AI Modular Box PC, Intel® Core™ i3-8100T Processor (4-core, 4-thread, 3.10 GHz) TDP 35W, two PCIe x4 and two PCIe x8 slots, four HDD bays, 250W PSU, R10 |
| FLEX-BX200-Q370-i5/25-R10* | 2U AI Modular Box PC, Intel® Core™ i5-8500T Processor (6-core, 6-thread, 2.1 GHz) TDP 35W, two PCIe x4 and two PCIe x8 slots, four HDD bays, 250W PSU, R10 |
| FLEX-BX200-Q370-i7/25-R10* | 2U AI Modular Box PC, Intel® Core™ i7-8700T Processor (6-core,12-thread,2.4 GHz) TDP 35W, two PCIe x4 and two PCIe x8 slots, four HDD bays, 250W PSU, R10 |
| FLEX-BX200-Q370-P/35-R10* | 2U AI Modular Box PC, Intel® Pentium® Gold G5400T Processor (2-core, 4-thread, 3.10 GHz) TDP 35W, two PCIe x4 and two PCIe x8 slots, four HDD bays, 350W PSU, R10 |
| FLEX-BX200-Q370-i3/35-R10* | 2U AI Modular Box PC, Intel® Core™ i3-8100T Processor (4-core, 4-thread, 3.10 GHz) TDP 35W, two PCIe x4 and two PCIe x8 slots, four HDD bays, 350W PSU, R10 |
| FLEX-BX200-Q370-i5/35-R10* | 2U AI Modular Box PC, Intel® Core™ i5-8500T Processor (6-core, 6-thread, 2.1 GHz) TDP 35W, two PCIe x4 and two PCIe x8 slots, four HDD bays, 350W PSU, R10 |
| FLEX-BX200-Q370-i7/35-R10* | 2U AI Modular Box PC, Intel® Core™ i7-8700T Processor (6-core,12-thread,2.4 GHz) TDP 35W, two PCIe x4 and two PCIe x8 slots, four HDD bays, 350W PSU, R10 |

*Build to order

Packing List

| Item | Q'ty | Remark |
|---------------------|------|--|
| 32702-000200-100-RS | 1 | European power cord, 1830mm |
| 41020-0521C2-00-RS | 2 | wall mount kit, black |
| 44035-040062-RS | 4 | M4*6 oval head screw for wall mount kit, black |
| | 1 | Key for HDD cover |

Options

| Part No. | Description |
|---------------|----------------|
| FLEX-BXRK-R10 | Rack mount kit |

I/O Interface

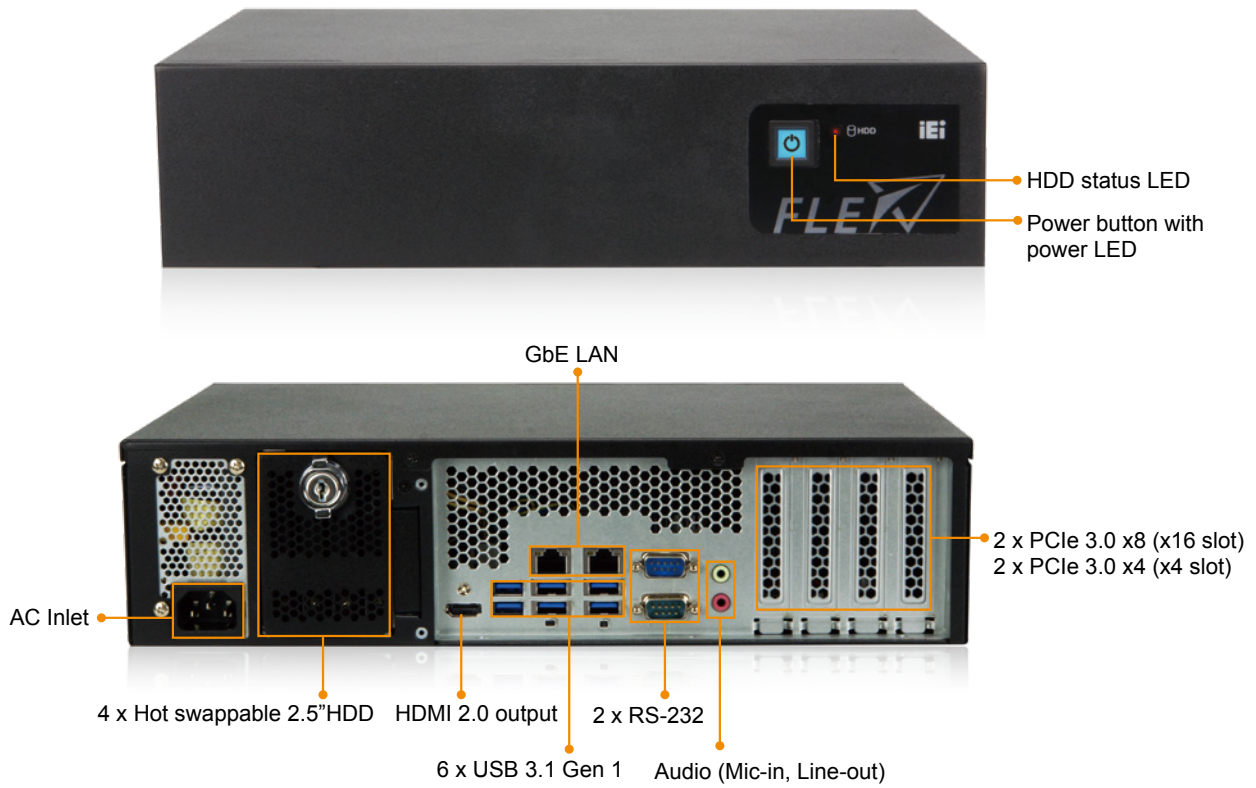

FLEX-BX200 Dimensions (Unit: mm)

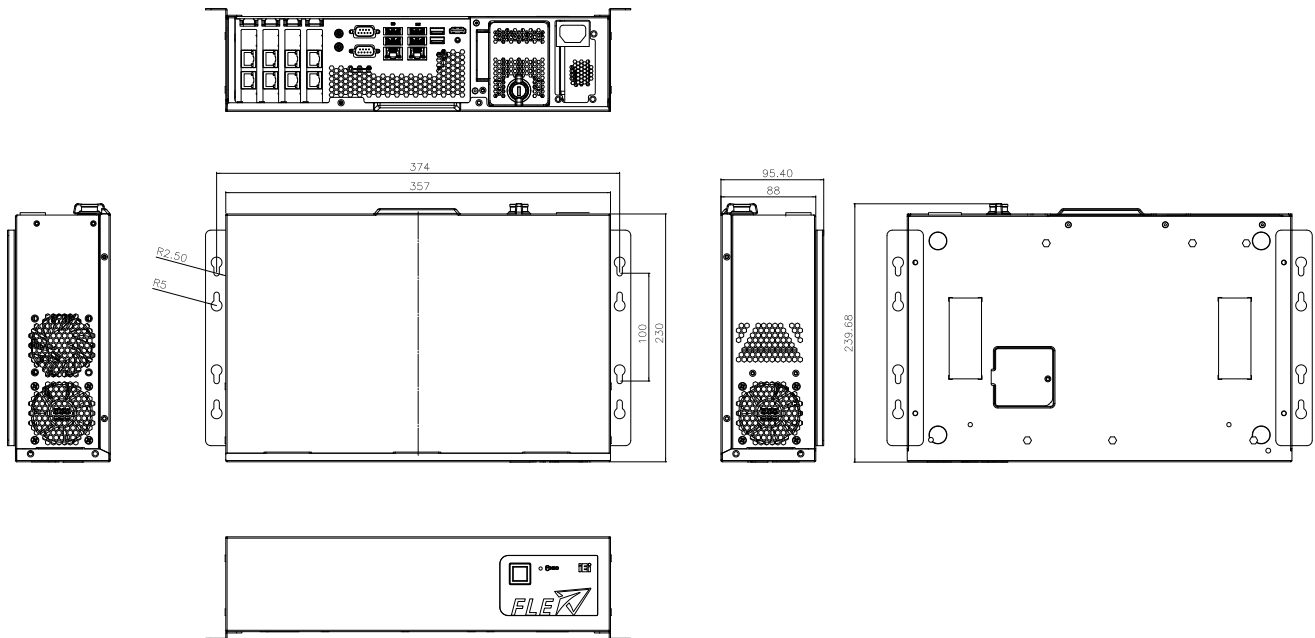

Configurable Systems

Panel Kit Modules



Specifications

| Model | | FLEX-PLKIT-F15 | FLEX-PLKIT-F17 | FLEX-PLKIT-FW15 | FLEX-PLKIT-FW19 | FLEX-PLKIT-FW22 | FLEX-PLKIT-FW24 |
|-----------------|--|----------------|----------------|-----------------|-----------------|-----------------|-----------------|
| TFT LCD | LCD Size | 15" | 17" | 15.6" | 18.5" | 21.5" | 23.8" |
| | Max. Resolution | 1024x768 | 1280x1024 | 1366x768 | 1366x768 | 1920x1080 | 1920x1080 |
| | Brightness (cd/m ²) | 450 | 350 | 400 | 400 | 250 | 250 |
| | Contrast Ratio | 800:1 | 1000:1 | 500:1 | 1000:1 | 1000:1 | 3000:1 |
| | LCD Color | 16.2M | 16.7M | 16.2M | 16.7M | 16.7M | 16.7M |
| | Viewing Angle (H/V) | 160°/150° | 170°/160° | 170°/160° | 170°/160° | 170°/160° | 178°/178° |
| | Backlight MTBF (Hrs) | 70,000 | 50,000 | 50,000 | 50,000 | 30,000 | 30,000 |
| Touch Screen | PCAP touch with 10-point multitouch and anti-glare coating | | | | | | |
| Video Interface | LVDS | | | | | | |
| IP Rating | IP66-rated front panel | | | | | | |
| Other | Support FLEX-BX200-Q370 only | | | | | | |

Ordering Information

| Part No. | Description |
|------------------------|--|
| FLEX-PLKIT-F15/PC-R10 | 15" 450cd/m ² 1024 x 768 FLEX modular resistive touch window/LCD kit, R10 |
| FLEX-PLKIT-F17/PC-R10 | 17" 350cd/m ² 1280 x 1024 FLEX modular PCAP touch window/LCD kit, R10 |
| FLEX-PLKIT-FW15/PC-R10 | 15.6" 400cd/m ² 1366 x 768 FLEX modular PCAP touch window/LCD kit, R10 |
| FLEX-PLKIT-FW19/PC-R10 | 18.5" 400cd/m ² 1366 x 768 FLEX modular PCAP touch window/LCD kit, R10 |
| FLEX-PLKIT-FW22/PC-R10 | 21.5" 250cd/m ² 1920 x 1080 FLEX modular PCAP touch window/LCD kit, R10 |
| FLEX-PLKIT-FW24/PC-R10 | 23.8" 250cd/m ² 1920 x 1080 FLEX modular PCAP touch window/LCD kit, R10 |

Options

| Item | FLEX-PLKIT-F15 | FLEX-PLKIT-FW15 | FLEX-PLKIT-F17 | FLEX-PLKIT-FW19 | FLEX-PLKIT-FW22 | FLEX-PLKIT-FW24 |
|-----------------|----------------|-----------------|----------------|-----------------|-----------------|-----------------|
| Panel Mount Kit | FPK-12-R10 | FPK-14-R10 | FPK-13-R10 | FPK-13-R10 | FPK-13-R10 | FPK-14-R10 |
| Rack Mount Kit | FRK15C-R10 | FRKW15C-R10 | FRK17C-R10 | FRKW19C-R10 | N.A. | N.A. |

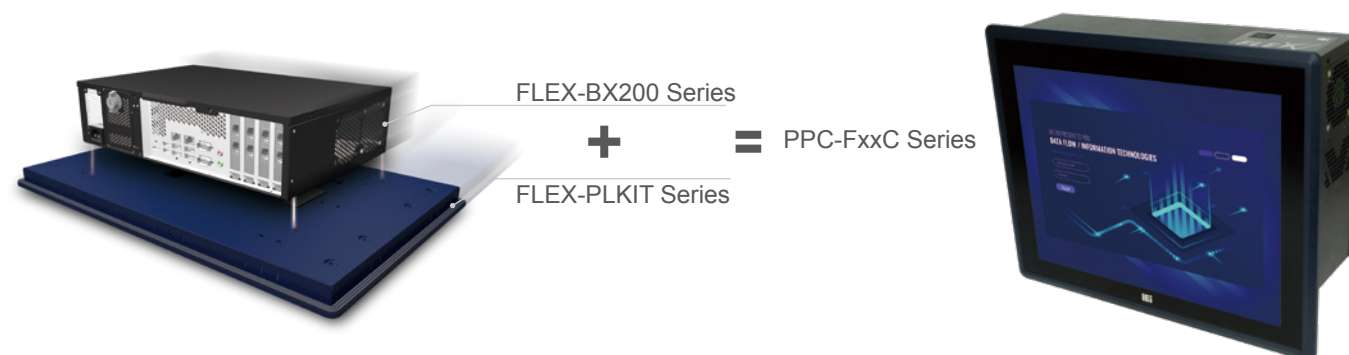

Configurable Systems

PPC-F15C-Q370 Dimensions (Unit: mm)

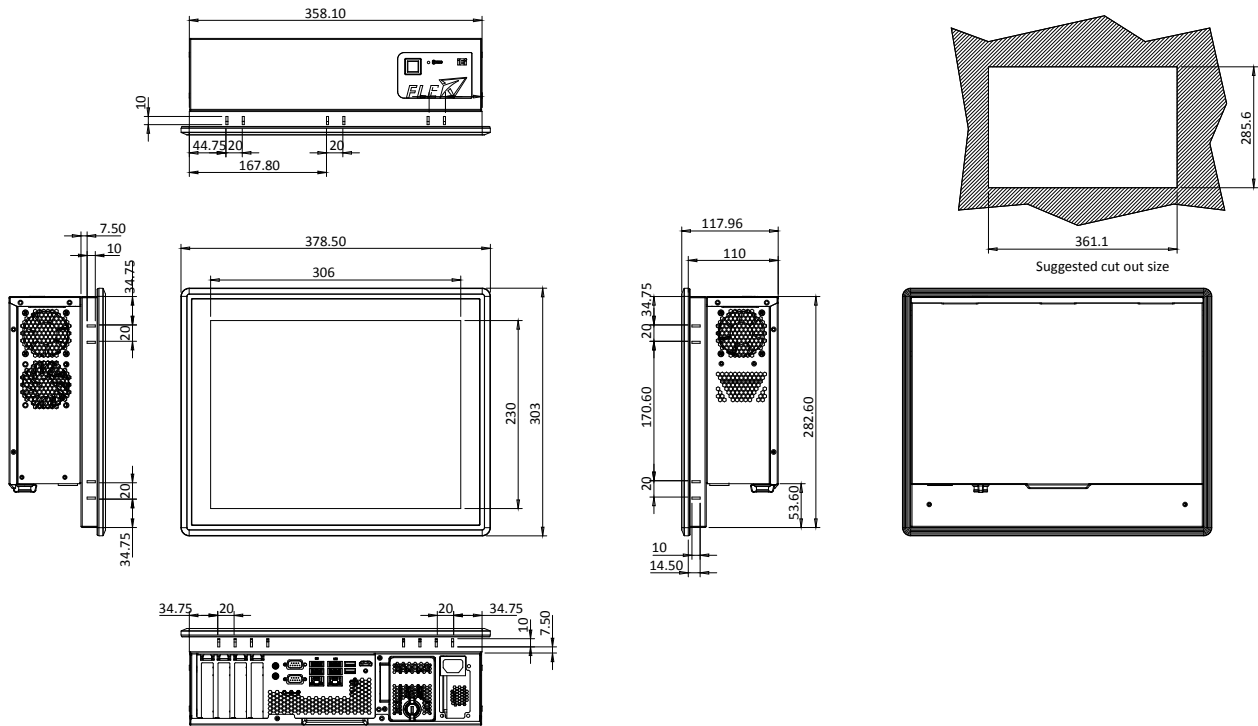

PPC-FW15C-Q370 Dimensions (Unit: mm)

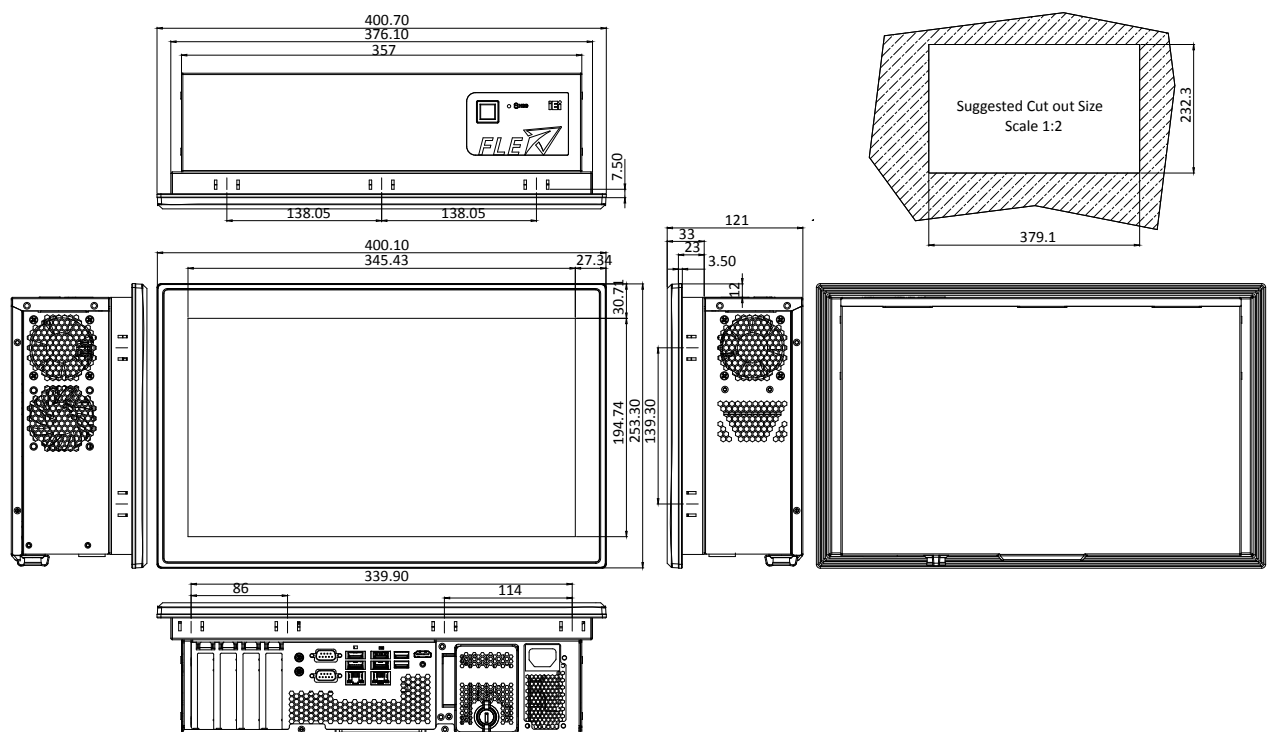

Configurable Systems

PPC-F17C-Q370 Dimensions (Unit: mm)

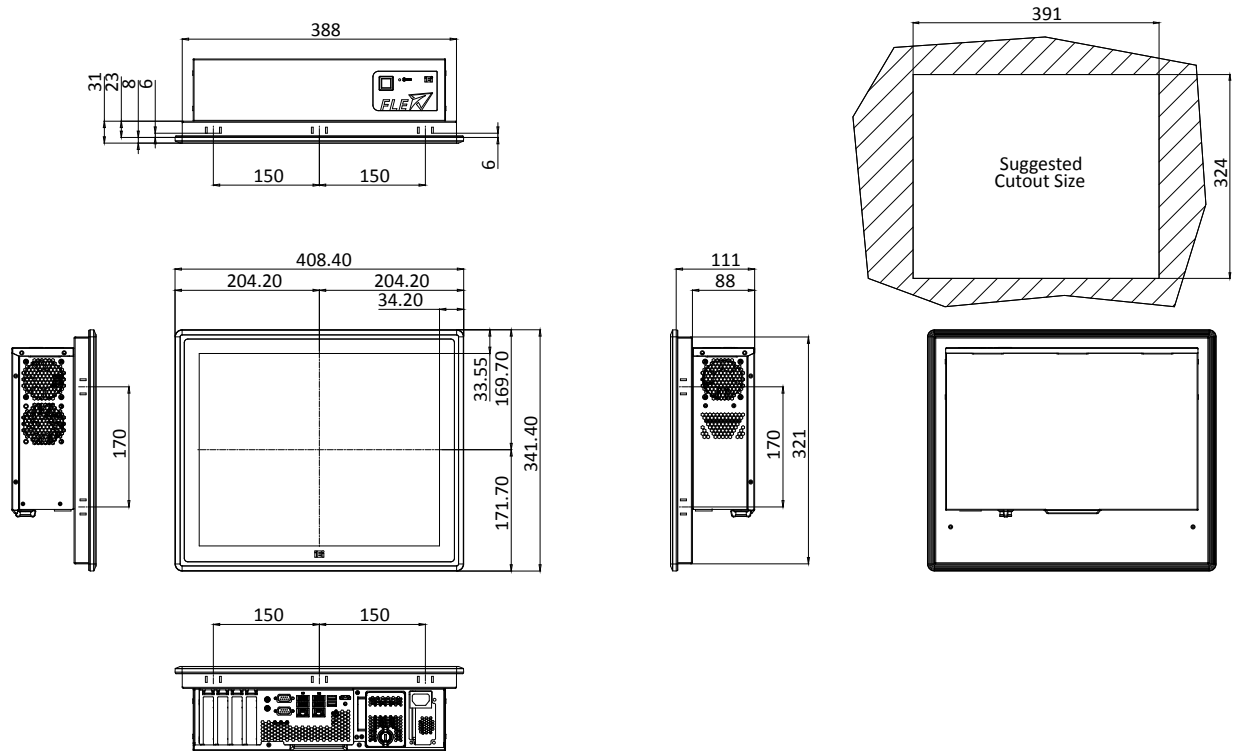

PPC-FW19C-Q370 Dimensions (Unit: mm)

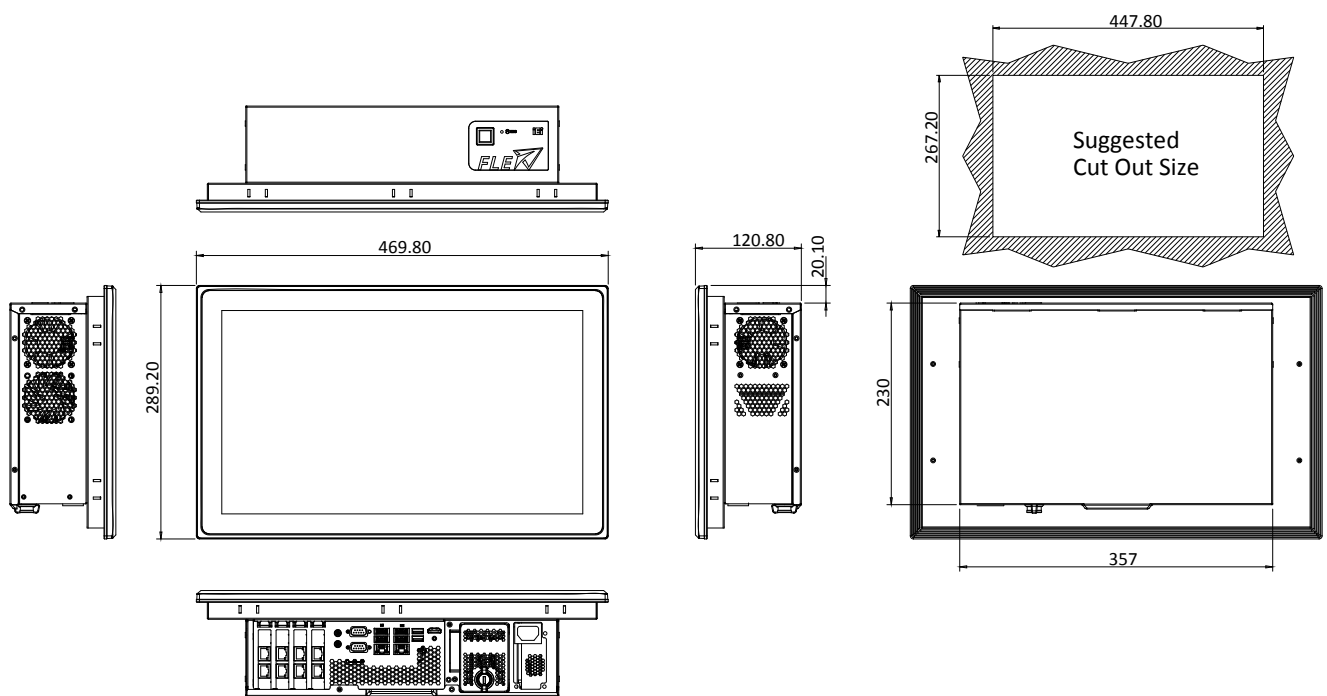

Configurable Systems

PPC-FW22C-Q370 Dimensions (Unit: mm)

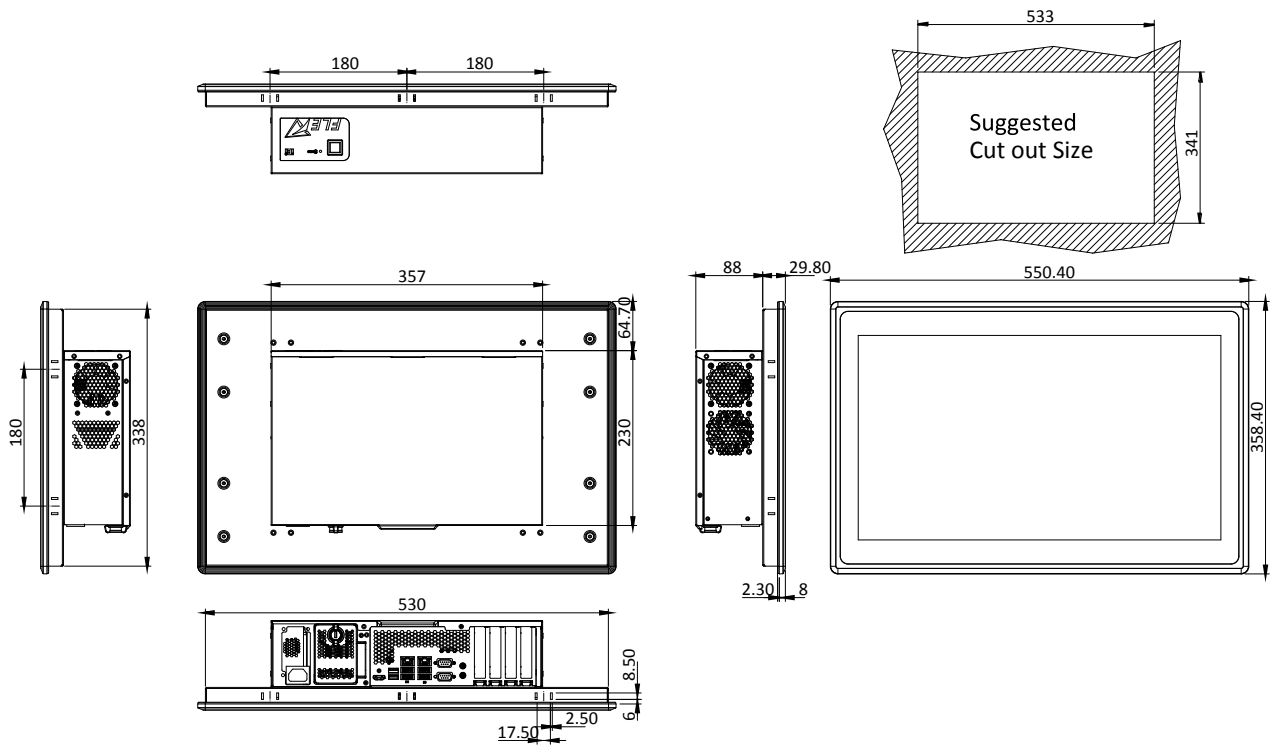

PPC-FW24C-Q370 Dimensions (Unit: mm)

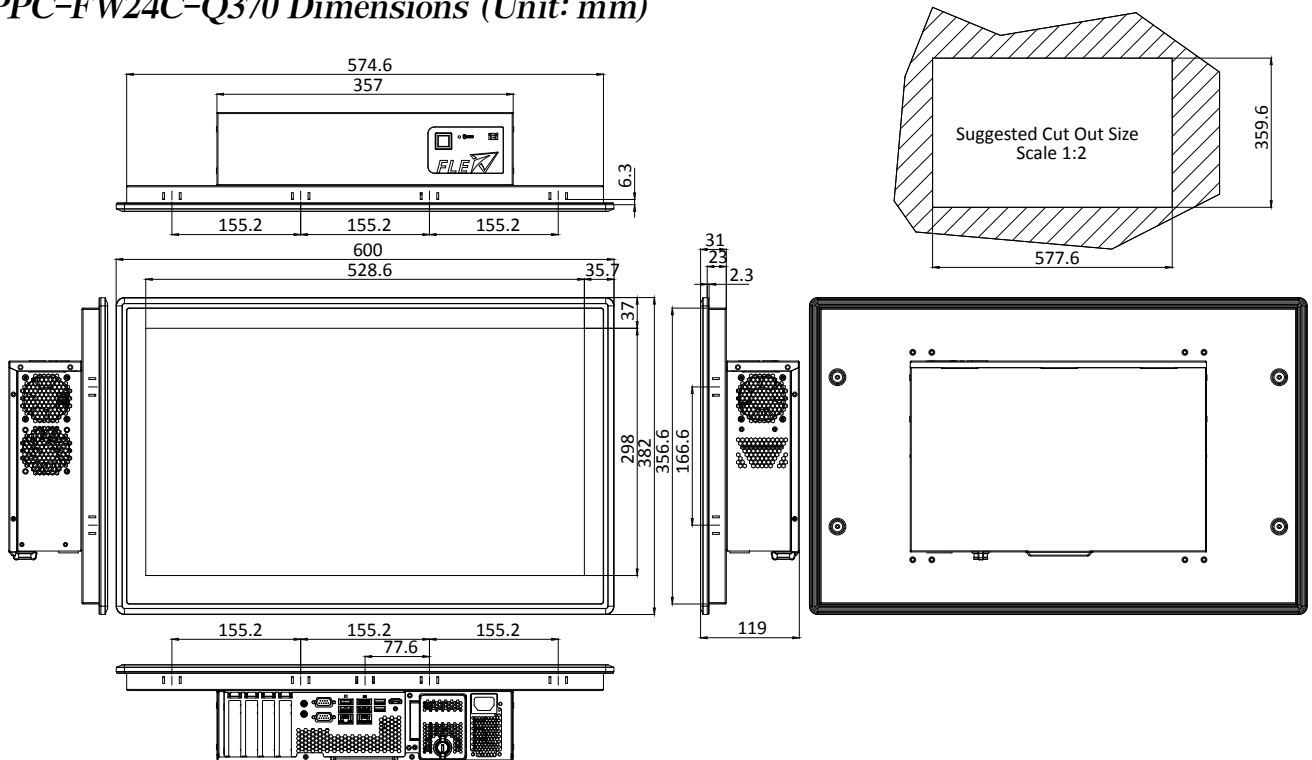



Стандарт Электрон Связь

Мы молодая и активно развивающаяся компания в области поставок электронных компонентов. Мы поставляем электронные компоненты отечественного и импортного производства напрямую от производителей и с крупнейших складов мира.

Благодаря сотрудничеству с мировыми поставщиками мы осуществляем комплексные и плановые поставки широчайшего спектра электронных компонентов.

Собственная эффективная логистика и склад в обеспечивает надежную поставку продукции в точно указанные сроки по всей России.

Мы осуществляем техническую поддержку нашим клиентам и предпродажную проверку качества продукции. На все поставляемые продукты мы предоставляем гарантию .

Осуществляем поставки продукции под контролем ВП МО РФ на предприятия военно-промышленного комплекса России , а также работаем в рамках 275 ФЗ с открытием отдельных счетов в уполномоченном банке. Система менеджмента качества компании соответствует требованиям ГОСТ ISO 9001.

Минимальные сроки поставки, гибкие цены, неограниченный ассортимент и индивидуальный подход к клиентам являются основой для выстраивания долгосрочного и эффективного сотрудничества с предприятиями радиоэлектронной промышленности, предприятиями ВПК и научно-исследовательскими институтами России.

С нами вы становитесь еще успешнее!

Наши контакты:

Телефон: +7 812 627 14 35

Электронная почта: sales@st-electron.ru

Адрес: 198099, Санкт-Петербург,
Промышленная ул, дом № 19, литера Н,
помещение 100-Н Офис 331