

LED Drivers for LCD Backlights

Backlight LED Driver for Small LCD Panels (Charge Pump Type)

BD1204GWL

No.10040EAT07

●Description

BD1204GWL is 3ch or 4ch parallel LED driver for the portable instruments.

This IC is equipped with an automatic transition charge pump and 16-step LED drivers. Hence this IC realizes high efficiency and high accuracy drive of LEDs. Additionally, this IC can synchronize LED drive with external PWM signal. This IC is best suited to turn on white LEDs that require high-accuracy LED brightness control.

●Features

- 1) 3ch or 4ch parallel LED driver is mounted
- 2) 16-step LED current adjust function
- 3) LED current matching is 5: 5% or less
- 4) Driving control via a single-line digital control interface
- 5) Automatic transition charge pump type DC/DC converter ($\times 1$, $\times 1.5$, $\times 2$)
- 6) High efficiency achieved (Maximum over 93%)
- 7) It transits for the most suitable power operating by the LED terminal process of the 4th light when 3 light driving
- 8) Various protection functions such as output voltage protection and thermal shutdown circuit are mounted.
- 9) The input external PWM is possible and the back light control interlocked with the motion picture is possible.
- 10) Package: UCSP50L1 (Thick 0.55mm MAX, Pin pitch 0.4mm) CSP14pin package

●Absolute maximum ratings (Ta=25°C)

Parameter	Symbol	Ratings	Unit
Power supply voltage	VMAX	7	V
Input voltage (EN , PWMIN)	Vdin	GND-0.3 ~ VBAT+0.3	V
Power dissipation	Pd	840	mW
Operating temperature range	Topr	-30 ~ +85	°C
Storage temperature range	Tstg	-55 ~ +150	°C

Note 1) The measurement value which was mounted on the PCB by ROHM.

When a glass epoxy substrate (70mm \times 70mm \times 1.6mm) has been mounted, this loss will decrease 6.72mW/°C if Ta is higher than or equal to 25°C.

●Operating Conditions (Ta = -30 ~ 85 °C)

Parameter	Symbol	Limits	Unit
Operating power supply voltage	VBAT	2.7 ~ 5.5	V

*This chip is not designed to protect itself against radioactive rays.

*This material may be changed on its way to designing.

*This material is not the official specification.

●Electrical Characteristics (Unless otherwise noted, Ta = +25°C, VBAT=3.6V)

Parameter	Symbol	Limits			Units	Conditions
		Min.	Typ.	Max.		
Current Consumption						
Quiescent Current	Iq	-	0.1	1	μA	EN=0V
Current Consumption1	Idd1	-	41.3	42.5	mA	x 1.0 Mode Include LED current (40mA)
Current Consumption2	Idd2	-	82.6	83.9	mA	x 2.0 Mode Include LED current (40mA)
Charge Pump						
Oscillator frequency	fOSC	0.56	0.85	1.14	MHz	
Current Source						
LED maximum current	ILED-max	18	20	22	mA	VBAT≥3.0V
LED current accuracy	ILED-diff	-	-	10.0	%	LED current setting is 10.0mA, LED terminal voltage is 1.0V
LED current matching	ILED-match	-	0.5	5.0	%	LED current setting is 10.0mA, LED terminal voltage is 1.0V
LED control voltage	VLED	-	0.15	0.25	V	Minimum voltage from LED1 to LED4 pins
Logic control terminal						
Low threshold voltage	VIL	-	-	0.4	V	EN , PWMIN
High threshold voltage	VIH	1.4	-	-	V	EN , PWMIN
High level Input current	IiH	-	0	1	μA	EN = VBAT, PWMIN = VBAT
Low level Input current	IiL	-1	0	-	μA	EN = 0V, PWMIN = 0V
Minimum EN High time	THI	0.05	-	100	μs	Described in Fig.5
Minimum EN Low time	TLO	0.3	-	100	μs	Described in Fig.5
EN Off Timeout	TOFF	1	-	-	ms	Described in Fig.5
Latch time	TLAT	1	-	-	ms	Described in Fig.5
Access available time	Tacc	1	-	5	ms	Described in Fig.5

●Block Diagram

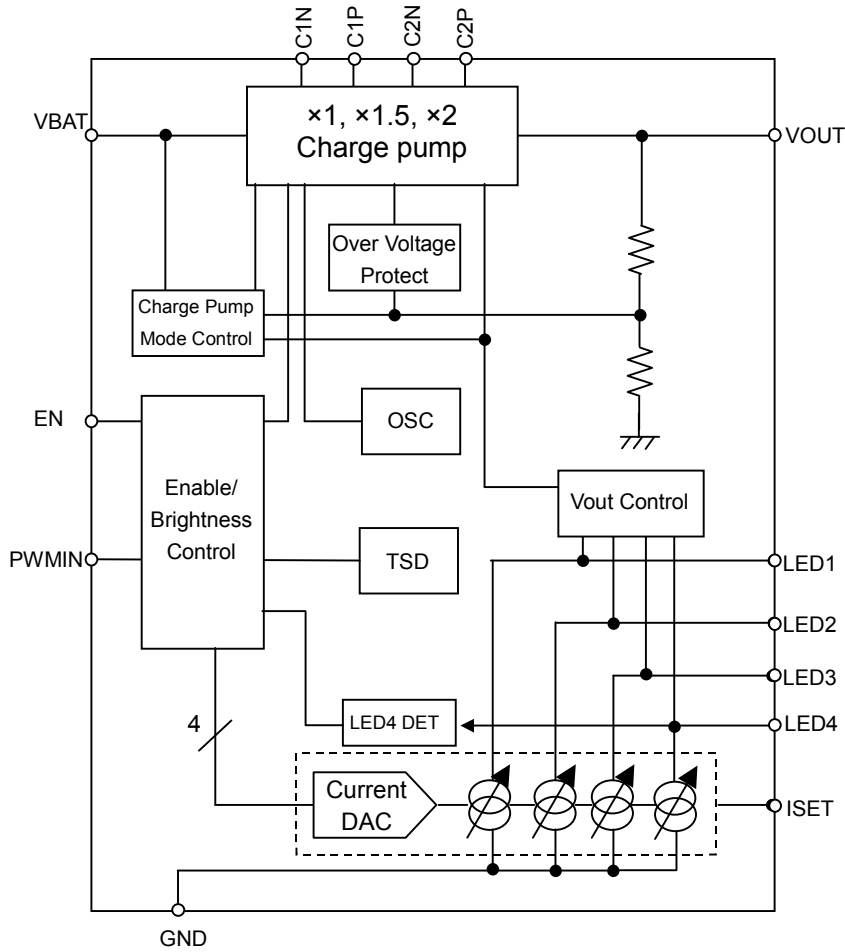

Pin number 14pin
Fig. 1 Block Diagram

●Pin Configuration [Bottom View]

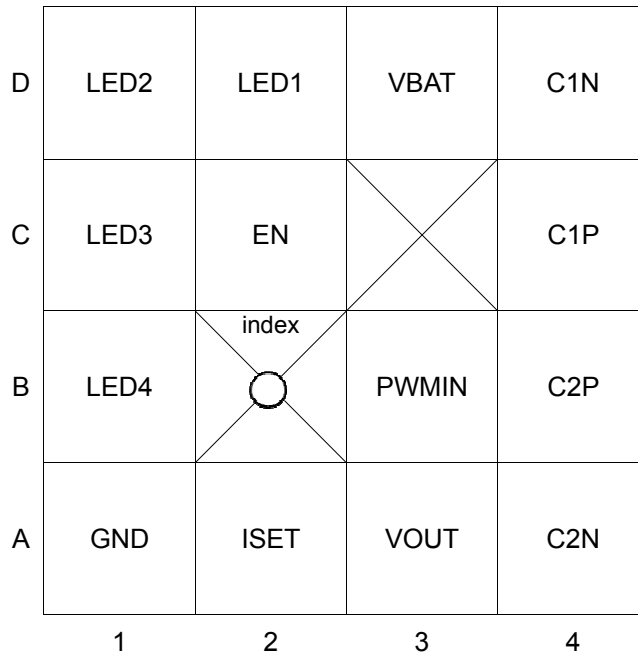

Fig. 2 Pin Configuration

●Package Outline

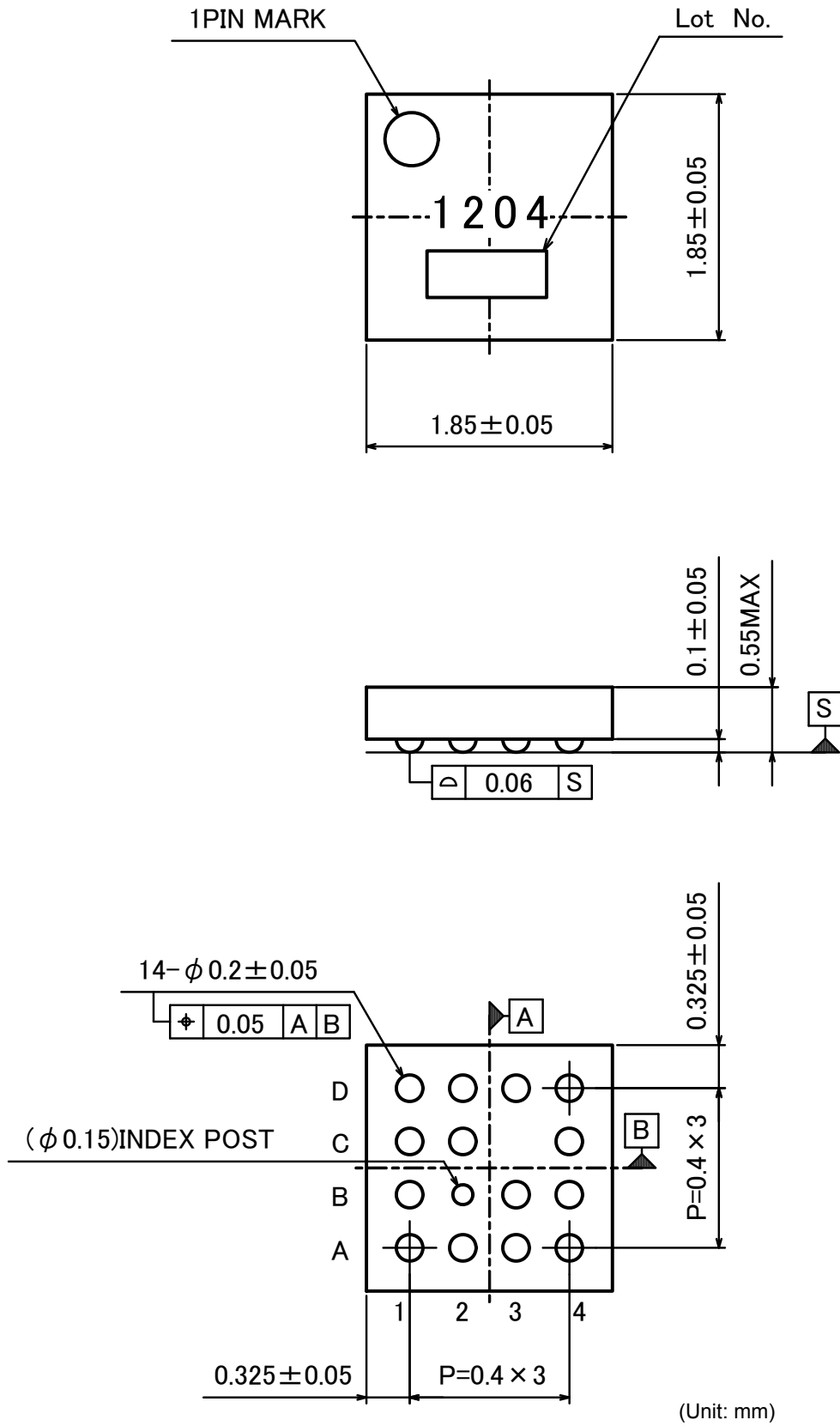

Fig. 3 Package Dimension

● Pin Descriptions

Pin No.	Terminal No.	Pin Name	In/Out	Type	Function
1	D3	VBAT	-	A	Power supply
2	C4	C1P	In/Out	A	Flying capacitor pin positive (+) side
3	D4	C1N	In/Out	B	Flying capacitor pin negative (-) side
4	B4	C2P	In/Out	A	Flying capacitor pin positive (+) side
5	A4	C2N	In/Out	B	Flying capacitor pin negative (-) side
6	A3	VOUT	Out	A	Charge pump output
7	C2	EN	In	C	ON/OFF and dimming control
8	D2	LED1	Out	A	LED current driver output 1
9	D1	LED2	Out	A	LED current driver output 2
10	C1	LED3	Out	A	LED current driver output 3
11	B1	LED4	Out	A	LED current driver output 4
12	B3	PWMIN	In	C	PWM Control
13	A1	GND	-	D	GND
14	A2	ISSET	Out	B	LED standard current

● Pin ESD Type

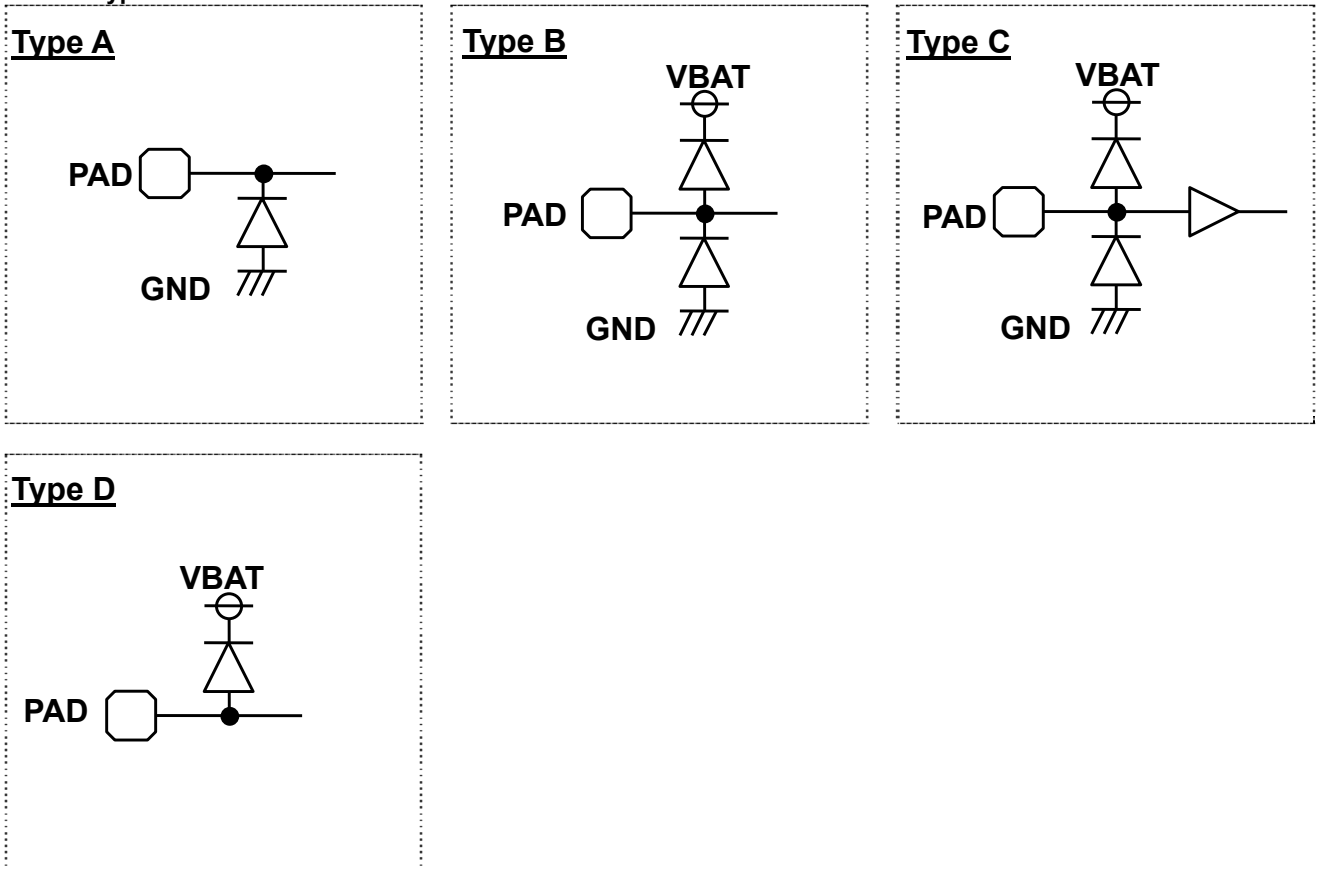

Fig. 4 Pin ESD Type

●Separate Function Description

(1) LED driver

a) Register access control protocol

LED current is controlled by only EN terminal. It is possible to access the register inside of this chip by using the protocol below. Accessing the registers with using this protocol operates LED driver ON/OFF and selecting the mode. Moreover, MAX current can be outputted without Clock input to EN terminal by holding H zone of fixed time after EN terminal starting.

< When setting current level >

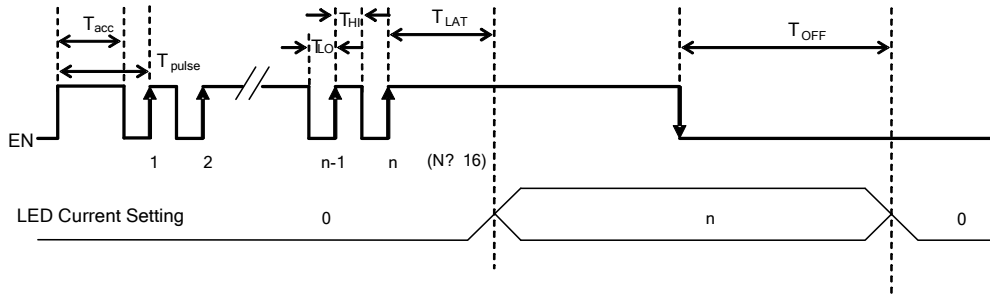

(Notes) $T_{accMIN} < T_{pulse} < T_{accMAX}$ Please input a pulse on this condition

< When starting by MAX setup >

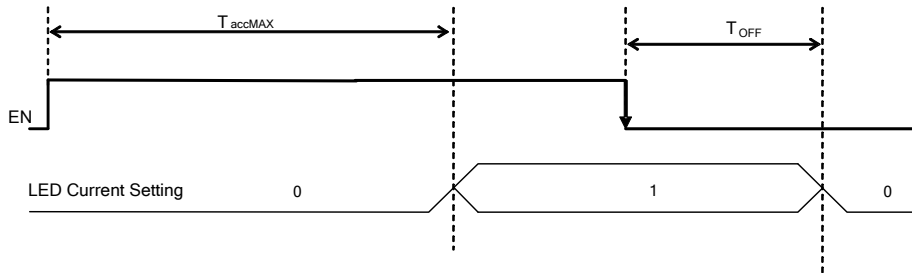

Fig.5 Register access protocol

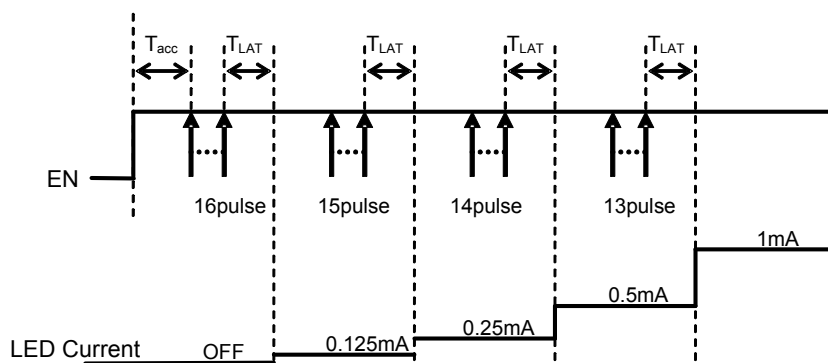

Fig.6 Slope control example

(Note)

- In the case of $N > 16$, BD1204GWL selects the mode of $N = 16$.
- LED current is changed by the pulse of EN pin.
Be careful to noise of EN signal.
- Reset BD1204GWL when the set is unusual. (Keep EN=L over Toff time.)

b) LED current level

The interface records rising edges of the EN pin and decodes them into 16 different indicated in following table.

Data	Output current [mA]	Data	Output current [mA]
1	20.0	9	5.0
2	17.0	10	4.0
3	14.0	11	3.0
4	12.0	12	2.0
5	10.0	13	1.0
6	8.5	14	0.5
7	7.0	15	0.25
8	6.0	16	0.125

(RISET=120 kΩ)

Moreover, LED current can be set up with the resistance RISET connected to ISET terminal, and the maximum current is decided by the following formula.

$$I_{LEDmax} [A] = 2.4 / RISET [k\Omega] \quad (Typ)$$

(2) Charge pump

a) Description of operations

Pin voltage comparison takes place at Vout control section, and then Vout generation takes place so that the LED cathode voltage with the highest Vf is set to 0.15V. A boost rate is changed automatically to a proper one at the Charge Pump Mode Control section so that operation can take place at possible low boost rate. In addition, when the VOUT output is short-circuited to GND, the leak current is suppressed via the overcurrent protection function.

b) Soft start function

BD1204GWL have a soft start function that prevents the rush current.

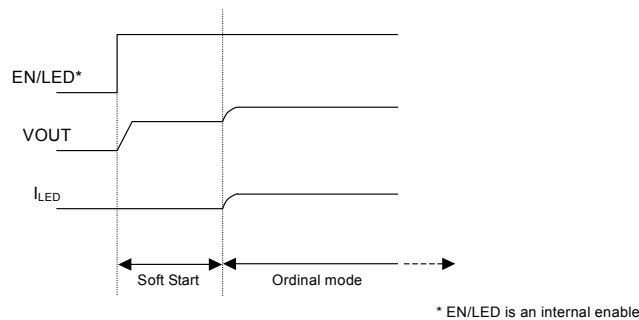

Fig.7 Soft Start

c) Automatic boost rate change

The boost rate automatically switches to the best mode.

* (×1 mode → ×1.5 mode) or (×1.5 mode → ×2 mode)

If a battery voltage drop occurs BD1204GWL cannot maintain the LED constant current, and then mode transition begins.

* (×1.5 mode → ×1 mode) or (×2 mode → ×1.5 mode)

If a battery voltage rise occurs, VOUT and VBAT detection are activated, and then mode transition begins.

(3) UVLO (Under Voltage Lock Out)

If the input voltage falls below 2.2V(Typ.), BD1204GWL is shut down to prevent malfunction due to ultra-low voltage.

(4) OVP (Over Voltage Protection)

This circuit protects this IC against damage when the C/P output voltage (VOUT) rises extremely for some external factors.

(5) Thermal shutdown (TSD)

To protect this IC against thermal damage or heat-driven uncontrolled operations, this circuit turns off the output if the chip temperature rises over 175°C. In addition, it turns on the output if the temperature returns to the normal temperature. Because the built-in thermal protection circuit is intended to protect the IC itself, the thermal shutdown detection temperature must be set to below 175°C in thermal design.

- (6) Power sequence
 EN signal must be released after VBAT voltage enough rise up.
 Prohibit the VBAT rise up during EN="H".

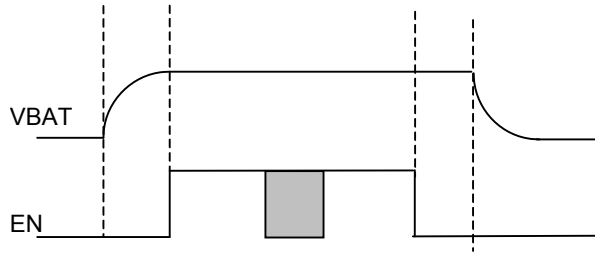

Fig.8 Power sequence

- (7) PWM control
 PWM control by the external terminal (PWMIN) is possible.
 It becomes PWM operation that used LED current by a register setup as the base and is the best for the brightness compensation by external control. If the application with is not use PWM, PWMIN pin must be short to VBAT.

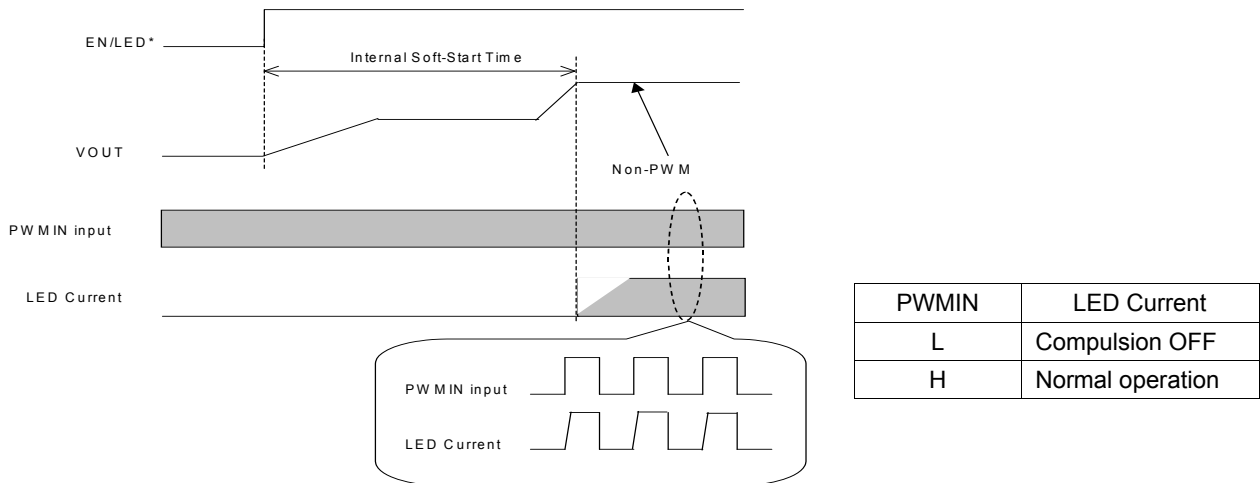

Fig.9 External PWM input solution

It is possible to make it a PWMIN input before EN/LED* is "H".
 A PWM drive becomes effective after the time of LED current standup.

When rising during PWM operation, as for the standup time of VOUT, only the rate of PWM Duty becomes late.
 Appearance may be influenced when extremely late frequency and extremely low Duty are inputted.
 Please secure over 120 μs "H" sections at the time of PWM pulse Force.

EN/LED* is an internal enable signal

●Application Circuit Example (4 light with PWM)

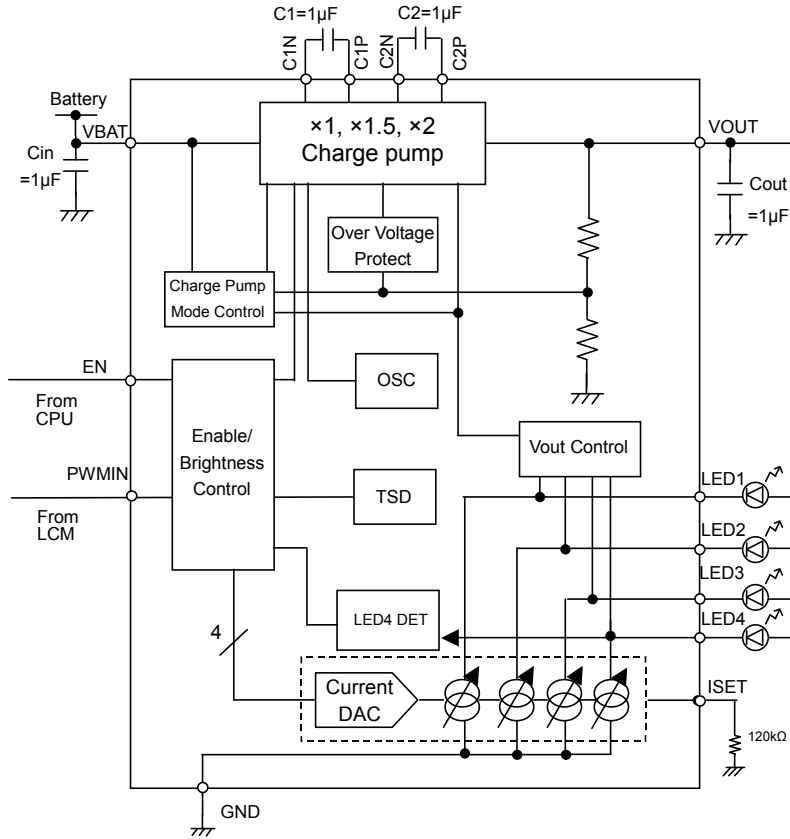

Fig.10 Application Circuit Example 1

●Application Circuit Example (3 light with PWM)

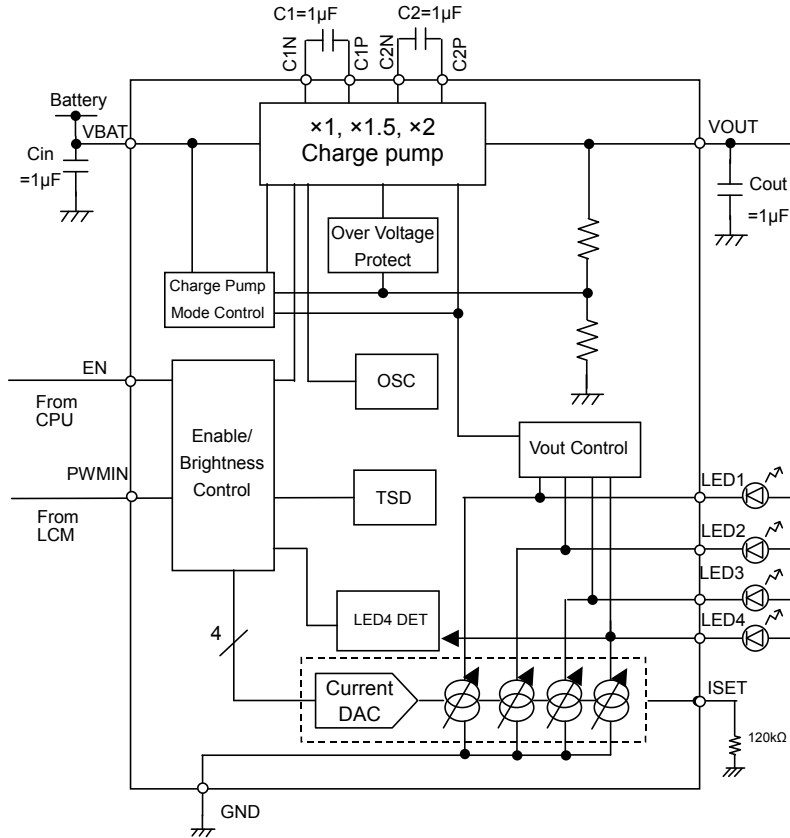

Fig.11 Application Circuit Example 2

●Application Circuit Example (4 light without PWM)

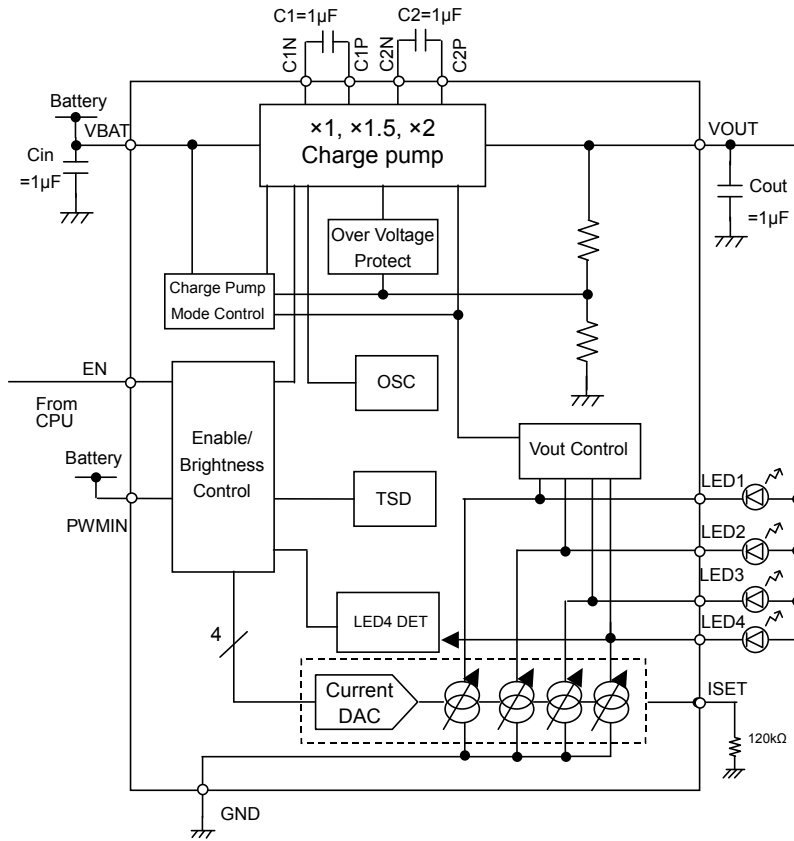

Fig.12 Application Circuit Example 3

●Notes for use

- (1) Absolute Maximum Ratings
An excess in the absolute maximum ratings, such as supply voltage, temperature range of operating conditions, etc., can break down devices, thus making impossible to identify breaking mode such as a short circuit or an open circuit. If any special mode exceeding the absolute maximum ratings is assumed, consideration should be given to take physical safety measures including the use of fuses, etc.
- (2) Power supply and ground line
Design PCB pattern to provide low impedance for the wiring between the power supply and the ground lines. Pay attention to the interference by common impedance of layout pattern when there are plural power supplies and ground lines. Especially, when there are ground pattern for small signal and ground pattern for large current included the external circuits, please separate each ground pattern. Furthermore, for all power supply pins to ICs, mount a capacitor between the power supply and the ground pin. At the same time, in order to use a capacitor, thoroughly check to be sure the characteristics of the capacitor to be used present no problem including the occurrence of capacity dropout at a low temperature, thus determining the constant.
- (3) Ground voltage
Make setting of the potential of the ground pin so that it will be maintained at the minimum in any operating state. Furthermore, check to be sure no pins are at a potential lower than the ground voltage including an actual electric transient.
- (4) Short circuit between pins and erroneous mounting
In order to mount ICs on a set PCB, pay thorough attention to the direction and offset of the ICs. Erroneous mounting can break down the ICs. Furthermore, if a short circuit occurs due to foreign matters entering between pins or between the pin and the power supply or the ground pin, the ICs can break down.
- (5) Operation in strong electromagnetic field
Be noted that using ICs in the strong electromagnetic field can malfunction them.
- (6) Input pins
In terms of the construction of IC, parasitic elements are inevitably formed in relation to potential. The operation of the parasitic element can cause interference with circuit operation, thus resulting in a malfunction and then breakdown of the input pin. Therefore, pay thorough attention not to handle the input pins, such as to apply to the input pins a voltage lower than the ground respectively, so that any parasitic element will operate. Furthermore, do not apply a voltage to the input pins when no power supply voltage is applied to the IC. In addition, even if the power supply voltage is applied, apply to the input pins a voltage lower than the power supply voltage or within the guaranteed value of electrical characteristics.
- (7) External capacitor
In order to use a ceramic capacitor as the external capacitor, determine the constant with consideration given to a degradation in the nominal capacitance due to DC bias and changes in the capacitance due to temperature, etc.
- (8) Thermal shutdown circuit
This LSI builds in a thermal shutdown circuit. When junction temperatures become detection temperature or higher, the thermal shutdown circuit operates and turns a switch OFF. The thermal shutdown circuit, which is aimed at isolating the LSI from thermal runaway as much as possible, is not aimed at the protection or guarantee of the LSI. Therefore, do not continuously use the LSI with this circuit operating or use the LSI assuming its operation.
- (9) Thermal design
Perform thermal design in which there are adequate margins by taking into account the permissible dissipation (Pd) in actual states of use.
- (10) About the pin for the test, the un-use pin
Prevent a problem from being in the pin for the test and the un-use pin under the state of actual use. Please refer to a function manual and an application notebook. And, as for the pin that doesn't specially have an explanation, ask our company person in charge.
- (11) About the rush current
For ICs with more than one power supply, it is possible that rush current may flow instantaneously due to the internal powering sequence and delays. Therefore, give special consideration to power coupling capacitance, power wiring, width of ground wiring, and routing of wiring.
- (12) About this document
This document is the design materials to design a set. So, the contents of the materials aren't always guaranteed. Please design application by having fully examination and evaluation include the external elements.

●Ordering part number

B	D
---	---

Part No.

1	2	0	4
---	---	---	---

Part No.

G	W	L
---	---	---

Package
GWL:UCSP50L1

E	2
---	---

Packaging and forming specification
E2: Embossed tape and reel

UCSP50L1(BD1204GWL)

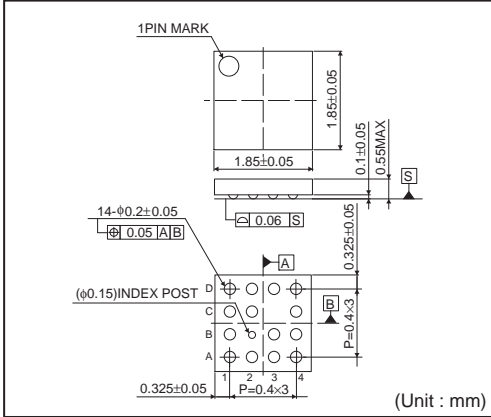

<Tape and Reel information>

Tape	Embossed carrier tape
Quantity	3000pcs
Direction of feed	E2 (The direction is the 1pin of product is at the upper left when you hold reel on the left hand and you pull out the tape on the right hand)

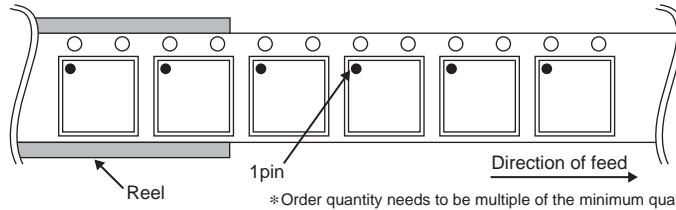

Notes

No copying or reproduction of this document, in part or in whole, is permitted without the consent of ROHM Co.,Ltd.

The content specified herein is subject to change for improvement without notice.

The content specified herein is for the purpose of introducing ROHM's products (hereinafter "Products"). If you wish to use any such Product, please be sure to refer to the specifications, which can be obtained from ROHM upon request.

Examples of application circuits, circuit constants and any other information contained herein illustrate the standard usage and operations of the Products. The peripheral conditions must be taken into account when designing circuits for mass production.

Great care was taken in ensuring the accuracy of the information specified in this document. However, should you incur any damage arising from any inaccuracy or misprint of such information, ROHM shall bear no responsibility for such damage.

The technical information specified herein is intended only to show the typical functions of and examples of application circuits for the Products. ROHM does not grant you, explicitly or implicitly, any license to use or exercise intellectual property or other rights held by ROHM and other parties. ROHM shall bear no responsibility whatsoever for any dispute arising from the use of such technical information.

The Products specified in this document are intended to be used with general-use electronic equipment or devices (such as audio visual equipment, office-automation equipment, communication devices, electronic appliances and amusement devices).

The Products specified in this document are not designed to be radiation tolerant.

While ROHM always makes efforts to enhance the quality and reliability of its Products, a Product may fail or malfunction for a variety of reasons.

Please be sure to implement in your equipment using the Products safety measures to guard against the possibility of physical injury, fire or any other damage caused in the event of the failure of any Product, such as derating, redundancy, fire control and fail-safe designs. ROHM shall bear no responsibility whatsoever for your use of any Product outside of the prescribed scope or not in accordance with the instruction manual.

The Products are not designed or manufactured to be used with any equipment, device or system which requires an extremely high level of reliability the failure or malfunction of which may result in a direct threat to human life or create a risk of human injury (such as a medical instrument, transportation equipment, aerospace machinery, nuclear-reactor controller, fuel-controller or other safety device). ROHM shall bear no responsibility in any way for use of any of the Products for the above special purposes. If a Product is intended to be used for any such special purpose, please contact a ROHM sales representative before purchasing.

If you intend to export or ship overseas any Product or technology specified herein that may be controlled under the Foreign Exchange and the Foreign Trade Law, you will be required to obtain a license or permit under the Law.



Thank you for your accessing to ROHM product informations.
More detail product informations and catalogs are available, please contact us.

ROHM Customer Support System

<http://www.rohm.com/contact/>



**Стандарт
Электрон
Связь**

Мы молодая и активно развивающаяся компания в области поставок электронных компонентов. Мы поставляем электронные компоненты отечественного и импортного производства напрямую от производителей и с крупнейших складов мира.

Благодаря сотрудничеству с мировыми поставщиками мы осуществляем комплексные и плановые поставки широчайшего спектра электронных компонентов.

Собственная эффективная логистика и склад в обеспечивает надежную поставку продукции в точно указанные сроки по всей России.

Мы осуществляем техническую поддержку нашим клиентам и предпродажную проверку качества продукции. На все поставляемые продукты мы предоставляем гарантию .

Осуществляем поставки продукции под контролем ВП МО РФ на предприятия военно-промышленного комплекса России , а также работаем в рамках 275 ФЗ с открытием отдельных счетов в уполномоченном банке. Система менеджмента качества компании соответствует требованиям ГОСТ ISO 9001.

Минимальные сроки поставки, гибкие цены, неограниченный ассортимент и индивидуальный подход к клиентам являются основой для выстраивания долгосрочного и эффективного сотрудничества с предприятиями радиоэлектронной промышленности, предприятиями ВПК и научно-исследовательскими институтами России.

С нами вы становитесь еще успешнее!

Наши контакты:

Телефон: +7 812 627 14 35

Электронная почта: sales@st-electron.ru

Адрес: 198099, Санкт-Петербург,
Промышленная ул, дом № 19, литера Н,
помещение 100-Н Офис 331