

64-Pin Super I/O with LPC Interface

Datasheet

Product Features

- 3.3 Volt Operation (5V tolerant)
- Programmable Wakeup Event Interface (IO_PME# Pin)
- SMI Support (IO_SMI# Pin)
- GPIOs (14)
- Two IRQ Input Pins
- XNOR Chain
- PC99a, PC2001
- ACPI 2.0 Compliant
- 64-pin STQFP Packages (2mm footprint)
- Intelligent Auto Power Management

- Serial Ports
 - One Full Function Serial Port
 - High Speed 16C550A Compatible UART with Send/Receive 16-Byte FIFO
 - Supports 230k and 460k Baud
 - Programmable Baud Rate Generator
 - Modem Control Circuitry

- Infrared Communications Controller
 - IrDA v1.2 (4Mbps), HPSIR, ASKIR, Consumer IR Support
 - 1 IR Port
 - 96 Base I/O Address, 15 IRQ Options and 3 DMA Options

- Multi-Mode Parallel Port with ChiProtectTM
 - Standard Mode IBM PC/XT[®], PC/AT[®], and PS/2[™] Compatible Bidirectional Parallel Port
 - Enhanced Parallel Port (EPP) Compatible - EPP 1.7 and EPP 1.9 (IEEE 1284 Compliant)
 - IEEE 1284 Compliant Enhanced Capabilities Port (ECP)
 - ChiProtect Circuitry for Protection Against Damage Due to Printer Power-On
 - 192 Base I/O Address, 15 IRQ and 3 DMA Options

- LPC Bus Host Interface
 - Multiplexed Command, Address and Data Bus
 - 8-Bit I/O Transfers
 - 8-Bit DMA Transfers
 - 16-Bit Address Qualification
 - Serial IRQ Interface Compatible with Serialized IRQ Support for PCI Systems
 - PCI CLKRUN# Support
 - Power Management Event (IO_PME#) Interface Pin



ORDERING INFORMATION

Order Number(s):

LPC47N217-JN for 64 pin STQFP package

LPC47N217-JV for 64 pin lead-free STQFP package



80 Arkay Drive
Hauppauge, NY 11788
(631) 435-6000
FAX (631) 273-3123

Copyright © SMSC 2004. All rights reserved.

Circuit diagrams and other information relating to SMSC products are included as a means of illustrating typical applications. Consequently, complete information sufficient for construction purposes is not necessarily given. Although the information has been checked and is believed to be accurate, no responsibility is assumed for inaccuracies. SMSC reserves the right to make changes to specifications and product descriptions at any time without notice. Contact your local SMSC sales office to obtain the latest specifications before placing your product order. The provision of this information does not convey to the purchaser of the described semiconductor devices any licenses under any patent rights or other intellectual property rights of SMSC or others. All sales are expressly conditional on your agreement to the terms and conditions of the most recently dated version of SMSC's standard Terms of Sale Agreement dated before the date of your order (the "Terms of Sale Agreement"). The product may contain design defects or errors known as anomalies which may cause the product's functions to deviate from published specifications. Anomaly sheets are available upon request. SMSC products are not designed, intended, authorized or warranted for use in any life support or other application where product failure could cause or contribute to personal injury or severe property damage. Any and all such uses without prior written approval of an Officer of SMSC and further testing and/or modification will be fully at the risk of the customer. Copies of this document or other SMSC literature, as well as the Terms of Sale Agreement, may be obtained by visiting SMSC's website at <http://www.smisc.com>. SMSC is a registered trademark of Standard Microsystems Corporation ("SMSC"). Product names and company names are the trademarks of their respective holders.

SMSC DISCLAIMS AND EXCLUDES ANY AND ALL WARRANTIES, INCLUDING WITHOUT LIMITATION ANY AND ALL IMPLIED WARRANTIES OF MERCHANTABILITY, FITNESS FOR A PARTICULAR PURPOSE, TITLE, AND AGAINST INFRINGEMENT AND THE LIKE, AND ANY AND ALL WARRANTIES ARISING FROM ANY COURSE OF DEALING OR USAGE OF TRADE.

IN NO EVENT SHALL SMSC BE LIABLE FOR ANY DIRECT, INCIDENTAL, INDIRECT, SPECIAL, PUNITIVE, OR CONSEQUENTIAL DAMAGES; OR FOR LOST DATA, PROFITS, SAVINGS OR REVENUES OF ANY KIND; REGARDLESS OF THE FORM OF ACTION, WHETHER BASED ON CONTRACT; TORT; NEGLIGENCE OF SMSC OR OTHERS; STRICT LIABILITY; BREACH OF WARRANTY; OR OTHERWISE; WHETHER OR NOT ANY REMEDY OF BUYER IS HELD TO HAVE FAILED OF ITS ESSENTIAL PURPOSE, AND WHETHER OR NOT SMSC HAS BEEN ADVISED OF THE POSSIBILITY OF SUCH DAMAGES.

Table of Contents

Chapter 1	General Description	9
Chapter 2	Pinout	10
Chapter 3	Pin Configuration	11
Chapter 4	Pin Description	12
4.1	Buffer Type Description	16
Chapter 5	Block Diagram	17
Chapter 6	3.3 Volt Operation / 5 Volt Tolerance	18
Chapter 7	Power Functionality	19
7.1	VCC Power	19
7.2	VTR Support	19
7.3	Internal PWRGOOD	19
7.4	Trickle Power Functionality	19
7.5	Maximum Current Values	20
7.6	Power Management Events (PME/SCI)	20
Chapter 8	Functional Description	21
8.1	Super I/O Registers	21
8.2	Host Processor Interface (LPC)	21
8.3	LPC Interface	21
8.3.1	LPC Interface Signal Definition	21
8.3.2	Power Management	23
8.3.3	LPC Transfers	25
Chapter 9	Serial Port (UART)	26
9.1	Register Description	26
9.1.1	Receive Buffer Register (RB)	27
9.1.2	Transmit Buffer Register (TB)	27
9.1.3	Interrupt Enable Register (IER)	27
9.1.4	FIFO Control Register (FCR)	28
9.1.5	Interrupt Identification Register (IIR)	28
9.1.6	Line Control Register (LCR)	30
9.1.7	Modem Control Register (MCR)	32
9.1.8	Line Status Register (LSR)	33
9.1.9	Modem Status Register (MSR)	34
9.1.10	Scratchpad Register (SCR)	35
9.2	Programmable Baud Rate Generator (AND Divisor Latches DLH, DLL)	35
9.3	Effect Of The Reset on Register File	35
9.4	FIFO Interrupt Mode Operation	36
9.5	FIFO Polled Mode Operation	37
9.6	Notes On Serial Port Operation	41
9.6.1	FIFO Mode Operation	41
9.6.2	TX AND RX FIFO Operation	41
Chapter 10	Infrared Interface	42
10.1	IrDA SIR/FIR and ASKIR	42
10.2	Consumer IR	42
10.3	Hardware Interface	42
10.4	IR Half Duplex Turnaround Delay Time	44
10.5	IR Transmit Pins	44
Chapter 11	Parallel Port	46
11.1	IBM XT/AT Compatible, Bi-Directional And EPP Modes	47
11.1.1	Data Port	47
11.1.2	Status Port	47
11.1.3	Control Port	48
11.1.4	EPP Address Port	49
11.1.5	EPP Data Port 0	49
11.1.6	EPP Data Port 1	49
11.1.7	EPP Data Port 2	50
11.1.8	EPP Data Port 3	50
11.2	EPP 1.9 Operation	50

11.2.1	<i>Software Constraints</i>	50
11.2.2	<i>EPP 1.9 Write</i>	50
11.2.3	<i>EPP 1.9 Read</i>	51
11.3	EPP 1.7 Operation	51
11.3.1	<i>Software Constraints</i>	52
11.3.2	<i>EPP 1.7 Write</i>	52
11.3.3	<i>EPP 1.7 Read</i>	52
11.4	Extended Capabilities Parallel Port	53
11.5	Vocabulary	53
11.6	ECP Implementation Standard	54
11.6.1	<i>Description</i>	54
11.6.2	<i>Register Definitions</i>	56
11.6.3	<i>Operation</i>	62
Chapter 12	Power Management	67
12.1	UART Power Management	67
12.1.1	<i>Exit Auto Powerdown</i>	67
12.2	Parallel Port	67
12.2.1	<i>Exit Auto Powerdown</i>	67
Chapter 13	Serial IRQ	68
13.1	Timing Diagrams For SER_IRQ Cycle	68
13.1.1	<i>SER_IRQ Cycle Control</i>	69
13.1.2	<i>SER_IRQ Data Frame</i>	69
13.1.3	<i>Stop Cycle Control</i>	70
13.1.4	<i>Latency</i>	70
13.1.5	<i>EOI/ISR Read Latency</i>	71
13.1.6	<i>AC/DC Specification Issue</i>	71
13.1.7	<i>Reset and Initialization</i>	71
13.2	Routable IRQ Inputs	71
Chapter 14	PCI CLKRUN Support	72
14.1	Overview	72
14.2	CLKRUN# for Serial IRQ	72
14.3	CLKRUN# for LDRQ#	72
14.4	Using CLKRUN#	72
Chapter 15	General Purpose I/O	74
15.1	GPIO Pins	74
15.2	Description	74
15.3	GPIO Control	75
15.4	GPIO Operation	76
15.5	GPIO PME and SMI Functionality	77
Chapter 16	System Management Interrupt (SMI)	78
16.1	SMI Registers	78
Chapter 17	PME Support	79
17.1	PME Registers	79
Chapter 18	Runtime Registers	80
18.1	Runtime Registers Block Summary	80
18.2	Runtime Registers Block Description	81
Chapter 19	Configuration	86
19.1	Configuration Access Ports	86
19.2	Configuration State	86
19.2.1	<i>Entering the Configuration State</i>	86
19.2.2	<i>Configuration Register Programming</i>	87
19.2.3	<i>Exiting the Configuration State</i>	87
19.2.4	<i>Programming Example</i>	87
19.2.5	<i>Configuration Select Register (CSR)</i>	87
19.3	Configuration Registers Summary	88
19.4	Configuration Registers Description	89
19.4.1	<i>CR00</i>	89
19.4.2	<i>CR01</i>	90
19.4.3	<i>CR02</i>	90

19.4.4	CR03	91
19.4.5	CR04	91
19.4.6	CR05	92
19.4.7	CR06	92
19.4.8	CR07	92
19.4.9	CR08	93
19.4.10	CR09	93
19.4.11	CR0A	94
19.4.12	CR0B	94
19.4.13	CR0C	95
19.4.14	CR0D	95
19.4.15	CR0E	95
19.4.16	CR0F	96
19.4.17	CR10	96
19.4.18	CR11	97
19.4.19	CR12 - CR13	97
19.4.20	CR14	98
19.4.21	CR15	99
19.4.22	CR16	99
19.4.23	CR17	99
19.4.24	CR18 - CR1E	100
19.4.25	CR1F	100
19.4.26	CR20	100
19.4.27	CR21	101
19.4.28	CR22	101
19.4.29	CR23	102
19.4.30	CR24	102
19.4.31	CR25	103
19.4.32	CR26	103
19.4.33	CR27	104
19.4.34	CR28	105
19.4.35	CR29	106
19.4.36	CR2A	106
19.4.37	CR2B	107
19.4.38	CR2C	107
19.4.39	CR2D	108
19.4.40	CR2E	108
19.4.41	CR2F	108
19.4.42	CR30	109
19.4.43	CR31	109
19.4.44	CR32	110
19.4.45	CR33	110
19.4.46	CR34	111
19.4.47	CR35	111
19.4.48	CR36	112
19.4.49	CR37	112
19.4.50	CR38	113
19.4.51	CR39	113
19.5	Logical Device Base I/O Address and Range	114
19.6	Note A. Logical Device IRQ and DMA Operation	115
Chapter 20	Operational Description	116
20.1	Maximum Guaranteed Ratings	116
20.2	DC Electrical Characteristics	116
20.3	Valid Power States	119
Chapter 21	Timing Diagrams	120
21.1	Power-Up Timing	120
21.2	Input Clock Timing	121
21.3	LPC Interface Timing	121
21.4	Parallel Port Timing	124
21.5	ECP Parallel Port Timing	127

21.6	IR Timing	131
21.7	Setup and Hold Timing for Serial IRQ's	135
21.8	UART Timing	135
Chapter 22	XNOR-Chain Test Mode	136
22.1	Entering and Exiting Test Mode	136
22.1.1	XNOR-Chain test mode can be entered as follows:	136
22.1.2	Exit XNOR-Chain test mode as follows:	136
22.2	Pin List of XNOR Chain	137
22.3	Setup of XNOR Chain	137
22.4	Testing Procedure	137
Chapter 23	Package Outline	139

List of Figures

Figure 3.1	- LPC47N217 Pin Configuration	11
Figure 5.1	- LPC47N217 Block Diagram	17
Figure 9.1	- Serial Data	30
Figure 10.1	- Infrared Interface Block Diagram	44
Figure 14.1	- CLKRUN# System Implementation Example	73
Figure 14.2	- Clock Start Illustration	73
Figure 15.1	- GPIO Function Illustration	76
Figure 21.1	- Power-Up Timing	120
Figure 21.2	- Input Clock Timing	121
Figure 21.3	- PCI Clock Timing	121
Figure 21.4	- Reset Timing	121
Figure 21.5	- Output Timing Measurement Conditions, LPC Signals	122
Figure 21.6	- Input Timing Measurement Conditions, LPC Signals	122
Figure 21.7	- I/O Write	122
Figure 21.8	- I/O Read	123
Figure 21.9	- DMA Request Assertion Through LDRQ#	123
Figure 21.10	- DMA Write (First Byte)	123
Figure 21.11	- DMA Read (First Byte)	123
Figure 21.12	- EPP 1.9 Data or Address Write Cycle	124
Figure 21.13	- EPP 1.9 Data or Address Read Cycle	125
Figure 21.14	- EPP 1.7 Data or Address Write Cycle	126
Figure 21.15	- EPP 1.7 Data or Address Read Cycle	126
Figure 21.16	- Parallel Port FIFO Timing	128
Figure 21.17	- ECP Parallel Port Forward Timing	129
Figure 21.18	- ECP Parallel Port Reverse Timing	130
Figure 21.19	- IrDA Receive Timing	131
Figure 21.20	- IrDA Transmit Timing	132
Figure 21.21	- Amplitude Shift Keyed IR Receive Timing	133
Figure 21.22	- Amplitude Shift Keyed IR Transmit Timing	134
Figure 21.23	- Setup and Hold Time	135
Figure 21.24	- Serial Port Data	135
Figure 22.1	- XNOR-Chain Test Structure	136
Figure 23.1	- 64 Pin STQFP Package Outline, 7X7X1.4 Body, 2 MM Footprint	139

List of Tables

Table 8.1	- Super I/O Block Addresses	21
Table 9.1	- Addressing the Serial Port	26
Table 9.2	- Interrupt Control Table	29
Table 9.3	- Baud Rates	37
Table 9.4	- Reset Function Table	38
Table 9.5	- Register Summary for an Individual UART Channel	39
Table 10.1	- FIR Transceiver Module-Type Select	43

Table 10.2 - IR Rx Data Pin Selection	43
Table 11.1 - Parallel Port Connector	46
Table 11.2 - EPP Pin Descriptions	53
Table 11.3 - Bit map of the Extended Parallel Port Registers	54
Table 11.4 - ECP Pin Descriptions	55
Table 11.5 - ECP Register Definitions	56
Table 11.6 - Mode Descriptions	56
Table 11.7A - Extended Control Register	62
Table 11.8 - Forward and Reverse Channel Commands	64
Table 13.1 - SER_IRQ Sampling Periods	70
Table 14.1 - LPC47N217 CLKRUN# Function	73
Table 15.1 - GPIO Pin Functionality	74
Table 15.2 - General Purpose I/O Port Assignments	75
Table 15.3 - GPIO Configuration Summary	76
Table 15.4 - GPIO Read/Write Behavior	77
Table 15.5 - PME and SMI Functionality	77
Table 18.1 - Runtime Register Block Summary	80
Table 18.2 - Runtime Registers Block Description	81
Table 19.1 - Configuration Access Ports	86
Table 19.2 - Configuration Registers Summary	88
Table 19.3 - CR00	89
Table 19.4 - CR01	90
Table 19.5 - CR02	90
Table 19.6 - CR03	91
Table 19.7 - CR04	91
Table 19.8 - CR05	92
Table 19.9 - CR06	92
Table 19.10 - CR07	92
Table 19.11 - CR09	93
Table 19.12 - CR0A	94
Table 19.13 - CR0B	94
Table 19.14 - CR0C	95
Table 19.15 - CR0F	96
Table 19.16 - CR10	96
Table 19.17 - CR11	97
Table 19.18 - CR12	98
Table 19.19 - CR13	98
Table 19.20 - CR14	98
Table 19.21 - CR15	99
Table 19.22 - CR17	99
Table 19.23 - CR1F	100
Table 19.24 - CR20	100
Table 19.25 - CR21	101
Table 19.26 - CR22	101
Table 19.27 - CR23	102
Table 19.28 - Parallel Port Addressing Options	102
Table 19.29 - CR24	102
Table 19.30 - CR25	103
Table 19.31 - CR26	103
Table 19.32 - DMA Selection	104
Table 19.33 - CR27	104
Table 19.34 - IRQ Encoding	105
Table 19.35 - CR28	105
Table 19.36 - UART Interrupt Operation	105
Table 19.37 - CR29	106
Table 19.38 - CR2A	106
Table 19.39 - CR2B	107
Table 19.40 - CR2C	107
Table 19.41 - CR2D	108
Table 19.42 - CR2E	108



Table 19.43 - CR2F.....	108
Table 19.44 - CR30.....	109
Table 19.45 - CR31.....	109
Table 19.46 - CR32.....	110
Table 19.47 - CR33.....	110
Table 19.48 - CR34.....	111
Table 19.49 - CR35.....	111
Table 19.50 - CR36.....	112
Table 19.51 - CR37.....	112
Table 19.52 - CR38.....	113
Table 19.53 - CR39.....	113
Table 19.54 - I/O Base Address Configuration Register Description.....	114
Table 23.1 - 64 Pin STQFP Package Parameters.....	139

Chapter 1 General Description

The SMSC LPC47N217 is a 3.3V PC 99, PC2001, and ACPI 2.0 compliant Super I/O Controller. The LPC47N217 implements the LPC interface, a pin reduced ISA interface which provides the same or better performance as the ISA/X-bus with a substantial savings in pins used. The part also includes 14 GPIO pins.

The LPC47N217 incorporates a 16C550A compatible UART and one Multi-Mode parallel port with ChiProtect[™] circuitry plus EPP and ECP support. This device also offers a full 16-bit internally decoded address bus, a Serial IRQ interface with PCI CLKRUN# support, relocatable configuration ports, and three DMA channel options.

The on-chip UART is compatible with the 16C550A. There is a dedicated Serial Infrared interface UART, which complies with IrDA v1.2 (Fast IR), HPSIR, and ASKIR formats (used by Sharp and other PDAs), as well as Consumer IR.

The parallel port is compatible with IBM PC/AT architectures, as well as IEEE 1284 EPP and ECP. The parallel port ChiProtect[™] circuitry prevents damage caused by an attached powered printer when the LPC47N217 is not powered.

The LPC47N217 features Software Configurable Logic (SCL) for ease of use. SCL allows programmable system configuration of key functions such as the parallel port and UART.

The LPC47N217 supports the ISA Plug-and-Play Standard register set (Version 1.0a) and provides the recommended functionality to support Windows operating systems, PC99, and PC2001. The I/O Address, DMA Channel, and Hardware IRQ of each device in the LPC47N217 may be reprogrammed through the internal configuration registers. There are multiple I/O address location options, a Serialized IRQ interface, and three DMA channels.

IBM, PC/XT and PC/AT are registered trademarks and PS/2 is a trademark of International Business Machines Corporation. SMSC is a registered trademark and ChiProtect, SuperCell, and Multi-Mode are trademarks of Standard Microsystems Corporation.

Chapter 2 Pinout

PIN #	NAME	PIN #	NAME	PIN #	NAME	PIN #	NAME
1	nRTS1	17	PCI_RESET#	33	GP11/SYSOPT	49	PD4
2	nCTS1	18	LPCPD#	34	GP12/IO_SMI#	50	PD5
3	nDTR1	19	CLKRUN#	35	GP13/IRQIN1	51	PD6
4	nRI1	20	PCI_CLK	36	GP14/IRQIN2	52	VSS
5	nDCD1	21	SER_IRQ	37	IRRX2	53	PD7
6	IO_PME#	22	VSS	38	IRTX2	54	VCC
7	VTR	23	GP40	39	IRMODE/IRRX3	55	SLCT
8	VSS	24	GP41	40	GP23	56	PE
9	CLOCKI	25	GP42	41	nINIT	57	BUSY
10	LAD0	26	VCC	42	nSLCTIN	58	nACK
11	VCC	27	GP43	43	VSS	59	nERROR
12	LAD1	28	GP44	44	PD0	60	nALF
13	LAD2	29	GP45	45	VCC	61	nSTROBE
14	LAD3	30	GP46	46	PD1	62	RXD1
15	LFRAME#	31	GP47	47	PD2	63	TXD1
16	LDRQ#	32	GP10	48	PD3	64	nDSR1

Chapter 3 Pin Configuration

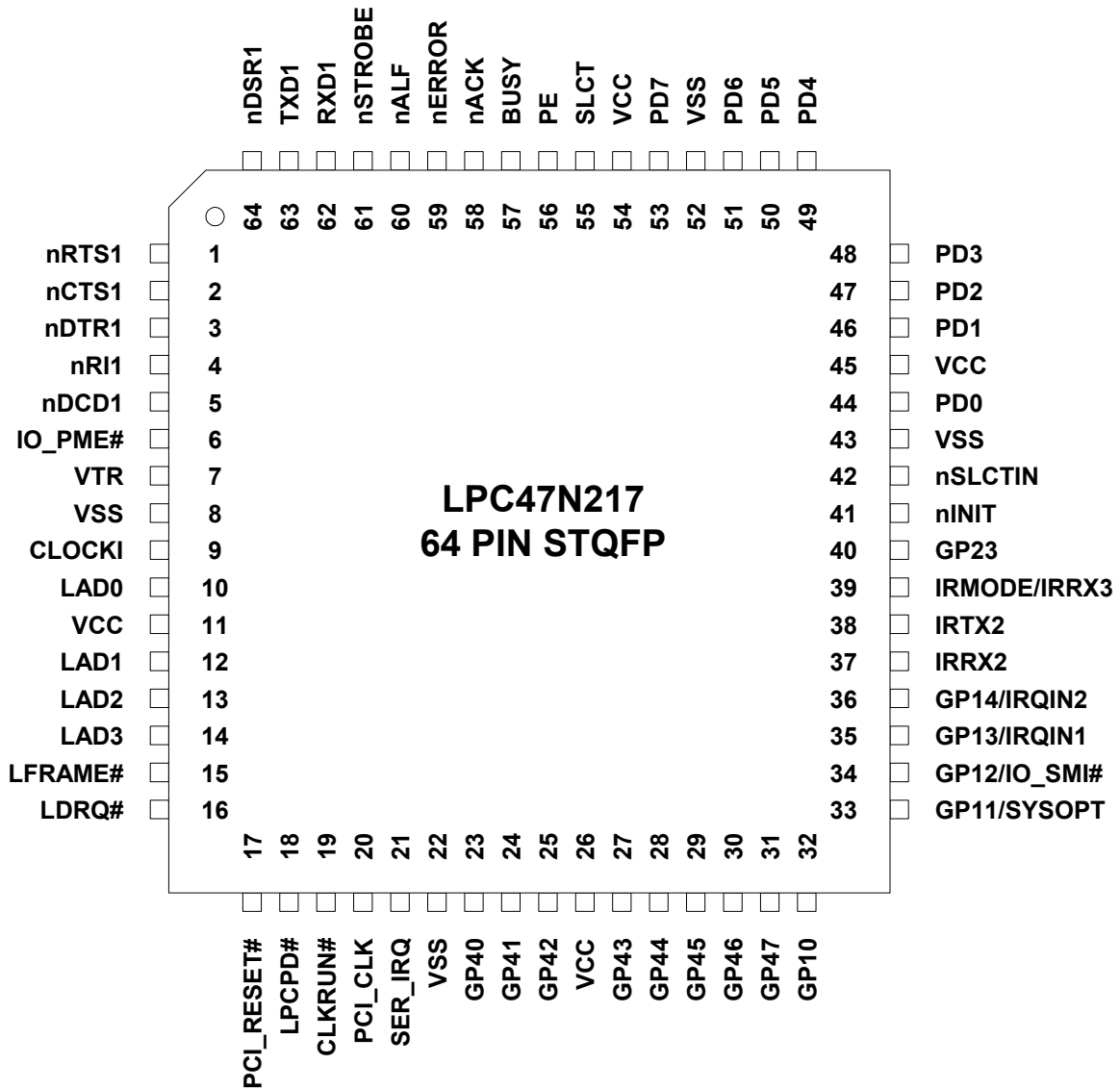

Figure 3.1 - LPC47N217 Pin Configuration

Chapter 4 Pin Description

PIN #	NAME	SYMBOL	BUFFER TYPE PER FUNCTION (NOTE 4.1)	DESCRIPTION
LPC INTERFACE (12)				
14:12, 10	LPC Address/ Data bus 3-0	LAD[3:0]	PCI_IO	Active high LPC signals used for multiplexed command, address and data bus.
15	LPC Frame	LFRAME#	PCI_I	Active low signal indicates start of new cycle and termination of broken cycle.
16	LPC DMA/Bus Master Request	LDRQ#	PCI_O	Active low signal used for encoded DMA/Bus Master request for the LPC interface.
17	PCI RESET	PCI_RESET#	PCI_I	Active low signal used as LPC Interface Reset.
18	LPC Power Down (Note 4.3)	LPCPD#	PCI_I	Active low Power Down signal indicates that the LPC47N217 should prepare for power to be shut on the LPC interface.
19	PCI Clock Controller	CLKRUN#	PCI_OD	This signal is used to indicate the PCI clock status and to request that a stopped clock be started.
20	PCI Clock	PCI_CLK	PCI_CLK	PCI clock input.
21	Serial IRQ	SER_IRQ	PCI_IO	Serial IRQ pin used with the PCI_CLK pin to transfer LPC47N217 interrupts to the host.
6	Power Mgt. Event	IO_PME#	(O12/OD12)	This active low Power Management Event signal allows the LPC47N217 to request wakeup.
SERIAL PORTS INTERFACE (8)				
62	Receive Data 1	RXD1	IS	Receiver serial data input for port 1.
63	Transmit Data 1	TXD1	O12	Transmit serial data output for port 1.
64	Data Set Ready 1	nDSR1	I	Active low Data Set Ready inputs for the serial port. Handshake signal which notifies the UART that the modem is ready to establish the communication link. The CPU can monitor the status of nDSR signal by reading bit 5 of Modem Status Register (MSR). A nDSR signal state change from low to high after the last MSR read will set MSR bit 1 to a 1. If bit 3 of Interrupt Enable Register is set, the interrupt is generated when nDSR changes state. Note: Bit 5 of MSR is the complement of nDSR.
1	Request to Send 1	nRTS1	O6	Active low Request to Send outputs for the Serial Port. Handshake output signal notifies modem that the UART is ready to transmit data. This signal can be programmed by writing to bit 1 of the Modem Control Register (MCR). The hardware reset will reset the nRTS signal to inactive mode (high). nRTS is forced inactive during loop mode operation.

PIN #	NAME	SYMBOL	BUFFER TYPE PER FUNCTION (NOTE 4.1)	DESCRIPTION
2	Clear to Send 1	nCTS1	I	Active low Clear to Send inputs for the serial port. Handshake signal which notifies the UART that the modem is ready to receive data. The CPU can monitor the status of nCTS signal by reading bit 4 of Modem Status Register (MSR). A nCTS signal state change from low to high after the last MSR read will set MSR bit 0 to a 1. If bit 3 of the Interrupt Enable Register is set, the interrupt is generated when nCTS changes state. The nCTS signal has no effect on the transmitter. Note: Bit 4 of MSR is the complement of nCTS.
3	Data Terminal Ready 1	nDTR1	O6	Active low Data Terminal Ready outputs for the serial port. Handshake output signal notifies modem that the UART is ready to establish data communication link. This signal can be programmed by writing to bit 0 of Modem Control Register (MCR). The hardware reset will reset the nDTR signal to inactive mode (high). nDTR is forced inactive during loop mode operation.
4	Ring Indicator 1	nRI1	I	Active low Ring Indicator inputs for the serial port. Handshake signal which notifies the UART that the telephone ring signal is detected by the modem. The CPU can monitor the status of nRI signal by reading bit 6 of Modem Status Register (MSR). A nRI signal state change from low to high after the last MSR read will set MSR bit 2 to a 1. If bit 3 of Interrupt Enable Register is set, the interrupt is generated when nRI changes state. Note: Bit 6 of MSR is the complement of nRI.
5	Data Carrier Detect 1	nDCD1	I	Active low Data Carrier Detect inputs for the serial port. Handshake signal which notifies the UART that carrier signal is detected by the modem. The CPU can monitor the status of nDCD signal by reading bit 7 of Modem Status Register (MSR). A nDCD signal state change from low to high after the last MSR read will set MSR bit 3 to a 1. If bit 3 of Interrupt Enable Register is set, the interrupt is generated when nDCD changes state. Note: Bit 7 of MSR is the complement of nDCD.
INFRARED INTERFACE (3)				
37	IR Receive	IRRX2 (Note 4.6)	IS	IR Receive.
38	IR Transmit	IRTX2 (Note 4.6)	O12	IR Transmit.
39	IR Mode/ IR Receive 3	IRMODE/ IRRX3	O6/ IS	IR mode. IR Receive 3.

PIN #	NAME	SYMBOL	BUFFER TYPE PER FUNCTION (NOTE 4.1)	DESCRIPTION
PARALLEL PORT INTERFACE (17)				
41	Initiate Output (Note 4.4)	nINIT	(OD14/OP14)	This output is bit 2 of the printer control register. This is used to initiate the printer when low. Refer to Parallel Port description for use of this pin in ECP and EPP mode.
42	Printer Select Input (Note 4.4)	nSLCTIN	(OD14/OP14)	This active low output selects the printer. This is the complement of bit 3 of the Printer Control Register. Refer to Parallel Port description for use of this pin in ECP and EPP mode.
44	Port Data 0	PD0	IOP14	Port Data 0
46	Port Data 1	PD1	IOP14	Port Data 1
47	Port Data 2	PD2	IOP14	Port Data 2
48	Port Data 3	PD3	IOP14	Port Data 3
49	Port Data 4	PD4	IOP14	Port Data 4
50	Port Data 5	PD5	IOP14	Port Data 5
51	Port Data 6	PD6	IOP14	Port Data 6
53	Port Data 7	PD7	IOP14	Port Data 7
55	Printer Selected Status	SLCT	I	This high active output from the printer indicates that it has power on. Bit 4 of the Printer Status Register reads the SLCT input. Refer to Parallel Port description for use of this pin in ECP and EPP mode.
56	Paper End	PE	I	Another status output from the printer, a high indicating that the printer is out of paper. Bit 5 of the Printer Status Register reads the PE input. Refer to Parallel Port description for use of this pin in ECP and EPP mode.
57	Busy	BUSY	I	This is a status output from the printer, a high indicating that the printer is not ready to receive new data. Bit 7 of the Printer Status Register is the complement of the BUSY input. Refer to Parallel Port description for use of this pin in ECP and EPP mode.
58	Acknowledge	nACK	I	A low active output from the printer indicating that it has received the data and is ready to accept new data. Bit 6 of the Printer Status Register reads the nACK input. Refer to Parallel Port description for use of this pin in ECP and EPP mode.
59	Error	nERROR	I	A low on this input from the printer indicates that there is a error condition at the printer. Bit 3 of the Printer Status register reads the nERR input. Refer to Parallel Port description for use of this pin in ECP and EPP mode.

PIN #	NAME	SYMBOL	BUFFER TYPE PER FUNCTION (NOTE 4.1)	DESCRIPTION
60	Autofeed Output (Note 4.4)	nALF	(OD14/OP14)	This output goes low to cause the printer to automatically feed one line after each line is printed. The nALF output is the complement of bit 1 of the Printer Control Register. Refer to Parallel Port description for use of this pin in ECP and EPP mode.
61	Strobe Output (Note 4.4)	nSTROBE	(OD14/OP14)	An active low pulse on this output is used to strobe the printer data into the printer. The nSTROBE output is the complement of bit 0 of the Printer Control Register. Refer to Parallel Port description for use of this pin in ECP and EPP mode.
GENERAL PURPOSE I/O (14)				
23-25, 27-31, 32	General Purpose I/O	GP40-GP47 GP10	(I/O8/OD8)	Dedicated General Purpose Input/Output.
33	General Purpose I/O (System Option) (Note 4.5)	GP11/ (SYSOPT)	(I/O8/OD8)	General Purpose Input/Output. At the trailing edge of hardware reset the GP11 pin is latched to determine the configuration base address: 0 = Index Base I/O Address 02E Hex; 1 = Index Base I/O Address 04E Hex.
34	General Purpose I/O/ System Mgt. Interrupt	GP12/ IO_SMI#	(I/O12/OD12)/ (O12/OD12)	General Purpose Input/Output. Active low System Management Interrupt Output.
35	General Purpose I/O/ IRQ Input 1	GP13/ IRQIN1	(I/O8/OD8)/ I	General Purpose Input/Output. External Interrupt Input. Steerable onto one of the 15 Serial IRQs.
36	General Purpose I/O/ IRQ Input 2	GP14/ IRQIN2	(I/O8/OD8)/ I	General Purpose Input/Output. External Interrupt Input. Steerable onto one of the 15 Serial IRQs.
40	General Purpose I/O	GP23	(I/O8/OD8)	General Purpose Input/Output.
CLOCK PINS (1)				
9	14MHz Clock	CLOCKI	IS	14.318MHz Clock Input.
POWER PINS (9)				
11, 26, 45, 54	VCC	VCC		+3.3 Volt Supply Voltage.
7	VTR	VTR		+3.3 Volt Standby Voltage.
8, 22, 43, 52	VSS	VSS		Ground.

Note 4.1 The "n" as the first letter of a signal name or the "#" as the suffix of a signal name indicates an "Active Low" signal.



Note 4.2 Buffer types per function on multiplexed pins are separated by a slash "/". Buffer types in parenthesis represent multiple buffer types for a single pin function.

Note 4.3 The LPCPD# pin may be tied high.

Note 4.4 Active (push-pull) output drivers are required on these pins in the enhanced parallel port modes.

Note 4.5 The GP11/SYSOPT pin requires an external pulldown resistor to put the base IO address for configuration at 0x02E. An external pullup resistor is required to move the base IO address for configuration to 0x04E.

Note 4.6 To activate the IRTX2 and IRRX2 pins set bits[7:6] IR Output Mux located in CR0A to '01'.

4.1 Buffer Type Description

I	Input TTL Compatible.
IS	Input with Schmitt Trigger.
O6	Output, 6mA sink, 3mA source.
O8	Output, 8mA sink, 4mA source.
OD8	Open Drain Output, 8mA sink.
IO8	Input/Output, 8mA sink, 4mA source.
O12	Output, 12mA sink, 6mA source.
OD12	Open Drain Output, 12mA sink.
IO12	Input/Output, 12mA sink, 6mA source.
OD14	Open Drain Output, 14mA sink.
OP14	Output, 14mA sink, 14mA source.
IOP14	Input/Output, 14mA sink, 14mA source. Backdrive protected.
PCI_I	Input. These pins meet the PCI 3.3V AC and DC Characteristics. (Note 4.7)
PCI_O	Output. These pins meet the PCI 3.3V AC and DC Characteristics. (Note 4.7)
PCI_OD	Open Drain Output. These pins meet the PCI 3.3V AC and DC Characteristics. (Note 4.7)
PCI_IO	Input/Output. These pins meet the PCI 3.3V AC and DC Characteristics. (Note 4.7)
PCI_ICLK	Clock Input. These pins meet the PCI 3.3V AC and DC Characteristics and timing. (Note 4.8)

Note 4.7 See the PCI Local Bus Specification, Revision 2.1, Section 4.2.2.

Note 4.8 See the PCI Local Bus Specification, Revision 2.1, Section 4.2.2. and 4.2.3.

Chapter 5 Block Diagram

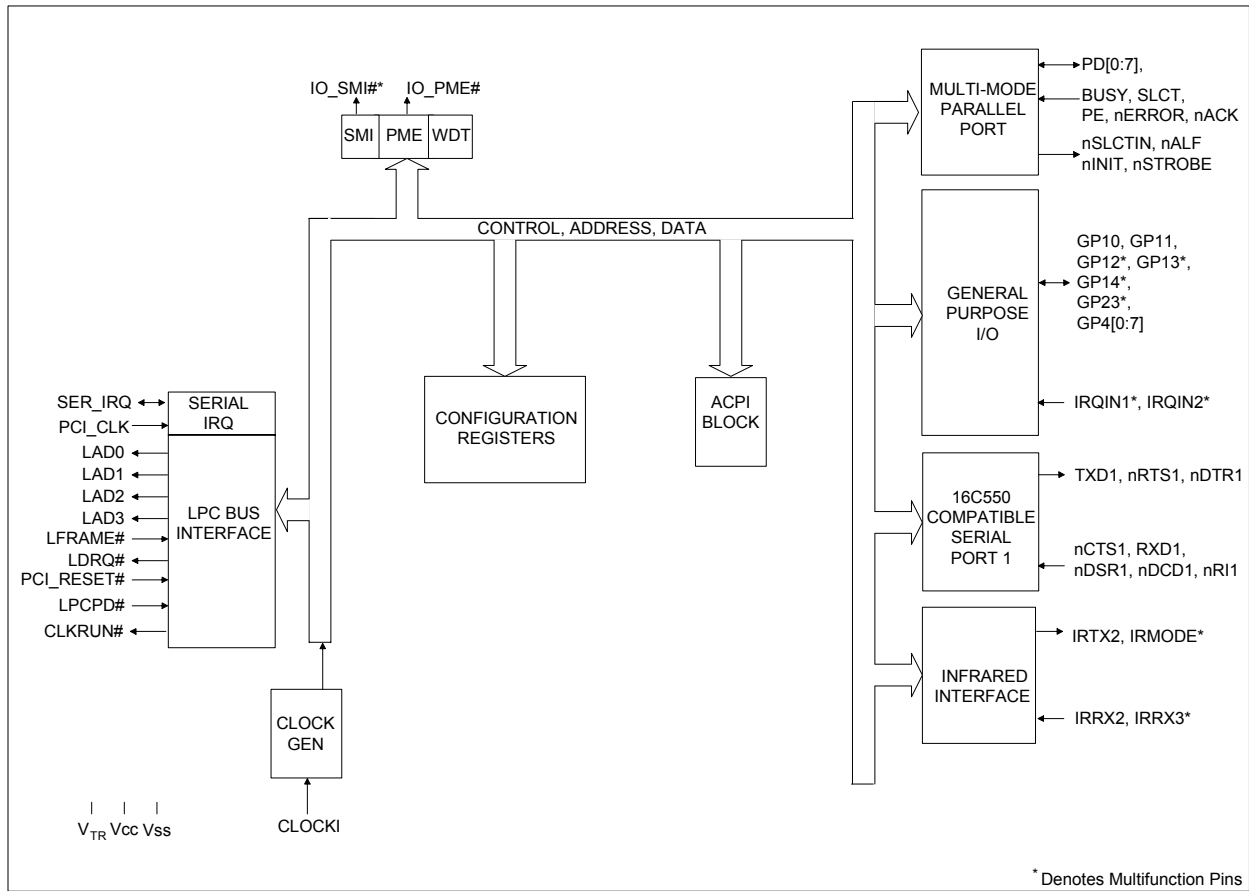

Figure 5.1 - LPC47N217 Block Diagram

Chapter 6 3.3 Volt Operation / 5 Volt Tolerance

The LPC47N217 is a 3.3 Volt part. It is intended solely for 3.3V applications. Non-LPC bus pins are 5V tolerant; that is, the input voltage is 5.5V max, and the I/O buffer output pads are backdrive protected.

The LPC interface pins are 3.3 V only. These signals meet PCI DC specifications for 3.3V signaling. These pins are:

- LAD[3:0]
- LFRAME#
- LDRQ#
- LPCPD#

The input voltage for all other pins is 5.5V max. These pins include all non-LPC Bus pins and the following pins:

- PCI_RESET#
- PCI_CLK
- SER_IRQ
- CLKRUN#
- IO_PME#

Chapter 7 Power Functionality

The LPC47N217 has two power planes: VCC and VTR.

7.1 VCC Power

The LPC47N217 is a 3.3 Volt part. The VCC supply is 3.3 Volts (nominal). See Chapter 20 - Operational Description and the Maximum Current Values subsection.

7.2 VTR Support

The LPC47N217 requires a trickle supply (VTR) to provide sleep current for the programmable wake-up events in the PME interface when VCC is removed. The VTR supply is 3.3 Volts (nominal). See the Operational Description section. The maximum VTR current that is required depends on the functions that are used in the part. See Trickle Power Functionality subsection and the Maximum Current Values subsection. If the LPC47N217 is not intended to provide wake-up capabilities on standby current, VTR can be connected to VCC. The VTR pin generates a VTR Power-on-Reset signal to initialize these components.

Note: If VTR is to be used for programmable wake-up events when VCC is removed, VTR must be at its full minimum potential at least 10 μ s before VCC begins a power-on cycle.

7.3 Internal PWRGOOD

An internal PWRGOOD logical control is included to minimize the effects of pin-state uncertainty in the host interface as VCC cycles on and off. When the internal PWRGOOD signal is “1” (active), VCC > 2.3V (nominal), and the LPC47N217 host interface is active. When the internal PWRGOOD signal is “0” (inactive), VCC \leq 2.3V (nominal), and the LPC47N217 host interface is inactive; that is, LPC bus reads and writes will not be decoded.

The LPC47N217 device pins IO_PME#, nRI1, and most GPIOs (as input) are part of the PME interface and remain active when the internal PWRGOOD signal has gone inactive, provided VTR is powered. See Section 7.4 - Trickle Power Functionality.

7.4 Trickle Power Functionality

When the LPC47N217 is running under VTR only, the PME wakeup events are active and (if enabled) able to assert the IO_PME# pin active low. The following lists the wakeup events:

- UART 1 Ring Indicator
- GPIOs for wakeup. See below.

The following requirements apply to all I/O pins that are specified to be 5 volt tolerant.

- I/O buffers that are wake-up event compatible are powered by VCC. Under VTR power (VCC=0), these pins may only be configured as inputs. These pins have input buffers into the wakeup logic that are powered by VTR.
- I/O buffers that may be configured as either push-pull or open drain under VTR power (VCC=0), are powered by VTR. This means they will, at a minimum, source their specified current from VTR even when VCC is present.



The GPIOs that are used for PME wakeup inputs are GP10-GP14, GP23. These GPIOs function as follows:

- Buffers are powered by VCC, but in the absence of VCC they are backdrive protected (they do not impose a load on any external VTR powered circuitry). They are wakeup compatible as inputs under VTR power. These pins have input buffers into the wakeup logic that are powered by VTR.

All GPIOs listed above are for PME wakeup as a GPIO function (or alternate function).

See the Table in the GPIO section for more information.

The following list summarizes the blocks, registers and pins that are powered by VTR.

- PME interface block
- Runtime register block (includes all PME, SMI, GP data registers)
- Pins for PME Wakeup:
 - GPIOs (GP10-GP14, GP23)
 - IO_PME#
 - nRI1

7.5 Maximum Current Values

See Chapter 20 - Operational Description for the maximum current values.

The maximum VTR current, I_{TR} , is given with all outputs open (not loaded), and all inputs in a fixed state (i.e., 0V or 3.3V). The total maximum current for the part is the unloaded value PLUS the maximum current sourced by the pin that is driven by VTR. The pin that is powered by VTR (as output) is IO_PME#. This pin, if configured as a push-pull output, will source a minimum of 6mA at 2.4V when driving.

The maximum VCC current, I_{CC} , is given with all outputs open (not loaded), and all inputs in a fixed state (i.e., 0V or 3.3V).

7.6 Power Management Events (PME/SCI)

The LPC47N217 offers support for Power Management Events (PMEs), also referred to as System Control Interrupt (SCI) events. The terms PME and SCI are used synonymously throughout this document to refer to the indication of an event to the chipset via the assertion of the IO_PME# pin. See PME Support - Chapter 17.

Chapter 8 Functional Description

8.1 Super I/O Registers

The address map, shown below in Table 8.1, shows the addresses of the different blocks of the Super I/O immediately after power up. The base addresses of the serial and parallel ports, runtime register block, and configuration register block can be moved via the configuration registers. Some addresses are used to access more than one register.

8.2 Host Processor Interface (LPC)

The host processor communicates with the LPC47N217 through a series of read/write registers via the LPC interface. The port addresses for these registers are shown in Table 8.1. Register access is accomplished through I/O cycles or DMA transfers. All registers are 8 bits wide.

Table 8.1 - Super I/O Block Addresses

ADDRESS	BLOCK NAME	NOTES
Base+(0-7)	Serial Port Com 1	
Base1+(0-7) Base2+(0-7)	Serial Port Com 2	IR Support FIR and CIR
Base+(0-3) Base+(0-7) Base+(0-3), +(400-402) Base+(0-7), +(400-402)	Parallel Port SPP EPP ECP ECP+EPP+SPP	
Base + (0-F)	Runtime Registers	
Base + (0-1)	Configuration	

Note 1: Refer to the configuration register descriptions for setting the base address.

8.3 LPC Interface

The following sub-sections specify the implementation of the LPC bus.

8.3.1 LPC Interface Signal Definition

The signals required for the LPC bus interface are described in the table below. LPC bus signals use PCI 33MHz electrical signal characteristics.

SIGNAL NAME	TYPE	DESCRIPTION
LAD[3:0]	I/O	LPC address/data bus. Multiplexed command, address and data bus.
LFRAME#	Input	Frame signal. Indicates start of new cycle and termination of broken cycle
PCI_RESET#	Input	PCI Reset. Used as LPC Interface Reset.
LDRQ#	Output	Encoded DMA/Bus Master request for the LPC interface.

SIGNAL NAME	TYPE	DESCRIPTION
IO_PME#	OD	Power Mgt Event signal. Allows the LPC47N217 to request wakeup.
LPCPD#	Input	Powerdown Signal. Indicates that the LPC47N217 should prepare for power to be shut on the LPC interface.
SER_IRQ	I/O	Serial IRQ.
PCI_CLK	Input	PCI Clock.
CLKRUN#	I/OD	Clock Run. Allows the LPC47N217 to request the stopped PCI_CLK be started.

8.3.1.1 LPC Cycles

The following cycle types are supported by the LPC protocol.

Cycle Type	Transfer Size
I/O Write	1 Byte
I/O Read	1 Byte
DMA Write	1 Byte
DMA Read	1 Byte

The LPC47N217 ignores cycles that it does not support.

8.3.1.2 Field Definitions

The data transfers are based on specific fields that are used in various combinations, depending on the cycle type. These fields are driven onto the LAD[3:0] signal lines to communicate address, control and data information over the LPC bus between the host and the LPC47N217. See the *Low Pin Count (LPC) Interface Specification* Revision 1.0 from Intel, Section 4.2 for definition of these fields.

8.3.1.3 LFRAME# Usage

LFRAME# is used by the host to indicate the start of cycles and the termination of cycles due to an abort or time-out condition. This signal is to be used by the LPC47N217 to know when to monitor the bus for a cycle.

This signal is used as a general notification that the LAD[3:0] lines contain information relative to the start or stop of a cycle, and that the LPC47N217 monitors the bus to determine whether the cycle is intended for it. The use of LFRAME# allows the LPC47N217 to enter a lower power state internally. There is no need for the LPC47N217 to monitor the bus when it is inactive, so it can decouple its state machines from the bus, and internally gate its clocks.

When the LPC47N217 samples LFRAME# active, it immediately stops driving the LAD[3:0] signal lines on the next clock and monitor the bus for new cycle information.

The LFRAME# signal functions as described in the *Low Pin Count (LPC) Interface Specification* Revision 1.0.

8.3.1.4 I/O Read and Write Cycles

The LPC47N217 is the target for I/O cycles. I/O cycles are initiated by the host for register or FIFO accesses, and will generally have minimal Sync times. The minimum number of wait-states between bytes is 1. EPP cycles will depend on the speed of the external device, and may have much longer Sync times.

Data transfers are assumed to be exactly 1-byte. If the CPU requested a 16 or 32-bit transfer, the host will break it up into 8-bit transfers.

See the *Low Pin Count (LPC) Interface Specification Reference*, Section 5.2, for the sequence of cycles for the I/O Read and Write cycles.

8.3.1.5 DMA Read and Write Cycles

DMA read cycles involve the transfer of data from the host (main memory) to the LPC47N217. DMA write cycles involve the transfer of data from the LPC47N217 to the host (main memory). Data will be coming from or going to a FIFO and will have minimal Sync times. Data transfers to/from the LPC47N217 are 1 byte.

See the *Low Pin Count (LPC) Interface Specification Reference*, Section 6.4, for the field definitions and the sequence of the DMA Read and Write cycles.

8.3.1.6 DMA Protocol

DMA on the LPC bus is handled through the use of the LDRQ# lines from the LPC47N217 and special encodings on LAD[3:0] from the host.

The DMA mechanism for the LPC bus is described in the Low Pin Count (LPC) Specification Revision 1.0.

8.3.2 Power Management

8.3.2.1 CLOCKRUN Protocol

See the *Low Pin Count (LPC) Interface Specification Reference*, Section 8.1.

8.3.2.2 LPCPD Protocol

The LPC47N217 will function properly if the LPCPD# signal goes active and then inactive again without PCI_RESET# becoming active. This is a requirement for notebook power management functions.

Although the LPC Bus spec 1.0 section 8.2 states, "After LPCPD# goes back inactive, the LPC I/F will always be reset using LRST#", this statement does not apply for mobile systems. LRST# (PCI_RESET#) will not occur if the LPC Bus power was not removed. For example, when exiting a "light" sleep state (ACPI S1, APM POS), LRST# (PCI_RESET#) will not occur. When exiting a "deeper" sleep state (ACPI S3-S5, APM STR, STD, soft-off), LRST# (PCI_RESET#) will occur.

The LPCPD# pin is implemented as a "local" powergood for the LPC bus in the LPC47N217. It is not used as a global powergood for the chip. It is used to reset the LPC block and hold it in reset.

An internal powergood is implemented in LPC47N217 to minimize power dissipation in the entire chip.

Prior to going to a low-power state, the system will assert the LPCPD# signal. It will go active at least 30 microseconds prior to the LCLK# (PCI_CLK) signal stopping low and power being shut to the other LPC I/F signals.

Upon recognizing LPCPD# active, the LPC47N217 will drive the LDRQ# signal low or tri-state, and do so until LPCPD# goes back active.

Upon recognizing LPCPD# inactive, the LPC47N217 will drive its LDRQ# signal high.

See the *Low Pin Count (LPC) Interface Specification Reference*, Section 8.2.

8.3.2.3 SYNC Protocol

See the *Low Pin Count (LPC) Interface Specification* Reference, Section 4.2.1.8 for a table of valid SYNC values.

8.3.2.4 Typical Usage

The SYNC pattern is used to add wait states. For read cycles, the LPC47N217 immediately drives the SYNC pattern upon recognizing the cycle. The host immediately drives the sync pattern for write cycles. If the LPC47N217 needs to assert wait states, it does so by driving 0101 or 0110 on LAD[3:0] until it is ready, at which point it will drive 0000 or 1001. The LPC47N217 will choose to assert 0101 or 0110, but not switch between the two patterns.

The data (or wait state SYNC) will immediately follow the 0000 or 1001 value.

The SYNC value of 0101 is intended to be used for normal wait states, wherein the cycle will complete within a few clocks. The LPC47N217 uses a SYNC of 0101 for all wait states in a DMA transfer.

The SYNC value of 0110 is intended to be used where the number of wait states is large. This is provided for EPP cycles, where the number of wait states could be quite large (>1 microsecond). However, the LPC47N217 uses a SYNC of 0110 for all wait states in an I/O transfer.

The SYNC value is driven within 3 clocks.

8.3.2.5 SYNC Timeout

The SYNC value is driven within 3 clocks. If the host observes 3 consecutive clocks without a valid SYNC pattern, it will abort the cycle.

The LPC47N217 does not assume any particular timeout. When the host is driving SYNC, it may have to insert a very large number of wait states, depending on PCI latencies and retries.

8.3.2.6 SYNC Patterns and Maximum Number of SYNCs

If the SYNC pattern is 0101, then the host assumes that the maximum number of SYNCs is 8.

If the SYNC pattern is 0110, then no maximum number of SYNCs is assumed. The LPC47N217 has protection mechanisms to complete the cycle. This is used for EPP data transfers and will utilize the same timeout protection that is in EPP.

8.3.2.7 SYNC Error Indication

The LPC47N217 reports errors via the LAD[3:0] = 1010 SYNC encoding.

If the host was reading data from the LPC47N217, data will still be transferred in the next two nibbles. This data may be invalid, but it will be transferred by the LPC47N217. If the host was writing data to the LPC47N217, the data had already been transferred.

In the case of multiple byte cycles, such as DMA cycles, an error SYNC terminates the cycle. Therefore, if the host is transferring 4 bytes from a device, if the device returns the error SYNC in the first byte, the other three bytes will not be transferred.

8.3.2.8 I/O and DMA START Fields

I/O and DMA cycles use a START field of 0000.

8.3.2.9 Reset Policy

The following rules govern the reset policy:

1. When PCI_RESET# goes inactive (high), the clock is assumed to have been running for 100usec prior to the removal of the reset signal, so that everything is stable. This is the same reset active time after clock is stable that is used for the PCI bus.
2. When PCI_RESET# goes active (low):
 - a) the host drives the LFRAME# signal high, tristates the LAD[3:0] signals, and ignores the LDRQ# signal.
 - b) the LPC47N217 ignores LFRAME#, tristate the LAD[3:0] pins and drive the LDRQ# signal inactive (high).

8.3.3 LPC Transfers

8.3.3.1 Wait State Requirements

I/O Transfers

The LPC47N217 inserts three wait states for an I/O read and two wait states for an I/O write cycle. A SYNC of 0110 is used for all I/O transfers. The exception to this is for transfers where IOCHRDY would be deasserted in an ISA transfer (i.e., EPP or IrCC transfers) in which case the sync pattern of 0110 is used and a large number of syncs may be inserted (up to 330 which corresponds to a timeout of 10us).

DMA Transfers

The LPC47N217 inserts three wait states for a DMA read and four wait states for a DMA write cycle. A SYNC of 0101 is used for all DMA transfers.

See the example timing for the LPC cycles in Chapter 21 - Timing Diagrams.

Chapter 9 Serial Port (UART)

The LPC47N217 incorporates one full function UART (UART 1), which is compatible with the 16450, the 16450 ACE registers and the 16C550A. The LPC47N217 also includes a reduced function UART (UART 2) to support the IR interface. See Chapter 10 Infrared Interface on page 42.

The UARTS perform serial-to-parallel conversion on received characters and parallel-to-serial conversion on transmit characters. The data rates are independently programmable from 460.8K baud down to 50 baud. The character options are programmable for 1 start; 1, 1.5 or 2 stop bits; even, odd, sticky or no parity; and prioritized interrupts. The UARTs each contain a programmable baud rate generator that is capable of dividing the input clock or crystal by a number from 1 to 65535. The UARTs are also capable of supporting the MIDI data rate. Refer to the Configuration Registers for information on disabling, power down and changing the base address of the UARTs. The interrupt from a UART is enabled by programming OUT2 of that UART to a logic "1". OUT2 being a logic "0" disables that UART's interrupt. The second UART also supports IrDA 1.2 (4Mbps), HP-SIR, ASK-IR and Consumer IR infrared modes of operation.

9.1 Register Description

Addressing of the accessible registers of the Serial Port is shown below. The base addresses of the serial ports are defined by the configuration registers (see Chapter 19 - Configuration). The Serial Port registers are located at sequentially increasing addresses above these base addresses. The LPC47N217 contains two serial ports, each of which contain a register set as described below.

Table 9.1 - Addressing the Serial Port

DLAB (NOTE 9.1)	A2	A1	A0	REGISTER NAME
0	0	0	0	Receive Buffer (read)
0	0	0	0	Transmit Buffer (write)
0	0	0	1	Interrupt Enable (read/write)
X	0	1	0	Interrupt Identification (read)
X	0	1	0	FIFO Control (write)
X	0	1	1	Line Control (read/write)
X	1	0	0	Modem Control (read/write)
X	1	0	1	Line Status (read/write)
X	1	1	0	Modem Status (read/write)
X	1	1	1	Scratchpad (read/write)
1	0	0	0	Divisor LSB (read/write)
1	0	0	1	Divisor MSB (read/write)

Note 9.1 DLAB is Bit 7 of the Line Control Register

The following section describes the operation of the registers.

9.1.1 Receive Buffer Register (RB)

Address Offset = 0H, DLAB = 0, READ ONLY

This register holds the received incoming data byte. Bit 0 is the least significant bit, which is transmitted and received first. Received data is double buffered; this uses an additional shift register to receive the serial data stream and convert it to a parallel 8 bit word which is transferred to the Receive Buffer register. The shift register is not accessible.

9.1.2 Transmit Buffer Register (TB)

Address Offset = 0H, DLAB = 0, WRITE ONLY

This register contains the data byte to be transmitted. The transmit buffer is double buffered, utilizing an additional shift register (not accessible) to convert the 8 bit data word to a serial format. This shift register is loaded from the Transmit Buffer when the transmission of the previous byte is complete.

9.1.3 Interrupt Enable Register (IER)

Address Offset = 1H, DLAB = 0, READ/WRITE

The lower four bits of this register control the enables of the five interrupt sources of the Serial Port interrupt. It is possible to totally disable the interrupt system by resetting bits 0 through 3 of this register. Similarly, setting the appropriate bits of this register to a high, selected interrupts can be enabled. Disabling the interrupt system inhibits the Interrupt Identification Register and disables any Serial Port interrupt out of the LPC47N217. All other system functions operate in their normal manner, including the Line Status and MODEM Status Registers. The contents of the Interrupt Enable Register are described below.

Bit 0

This bit enables the Received Data Available Interrupt (and timeout interrupts in the FIFO mode) when set to logic "1".

Bit 1

This bit enables the Transmitter Holding Register Empty Interrupt when set to logic "1".

Bit 2

This bit enables the Received Line Status Interrupt when set to logic "1". The error sources causing the interrupt are Overrun, Parity, Framing and Break. The Line Status Register must be read to determine the source.

Bit 3

This bit enables the MODEM Status Interrupt when set to logic "1". This is caused when one of the Modem Status Register bits changes state.

Bits 4 through 7

These bits are always logic "0".

9.1.4 FIFO Control Register (FCR)

Address Offset = 2H, DLAB = X, WRITE

This is a write only register at the same location as the IIR. This register is used to enable and clear the FIFOs, set the RCVR FIFO trigger level. Note: DMA is not supported. The UART1 and UART2 FCR's are shadowed in the UART1 FIFO Control Shadow Register (CR15) and UART2 FIFO Control Shadow Register (CR16). See Chapter 19 - Configuration for description on these registers.

Bit 0

Setting this bit to a logic "1" enables both the XMIT and RCVR FIFOs. Clearing this bit to a logic "0" disables both the XMIT and RCVR FIFOs and clears all bytes from both FIFOs. When changing from FIFO Mode to non-FIFO (16450) mode, data is automatically cleared from the FIFOs. This bit must be a 1 when other bits in this register are written to or they will not be properly programmed.

Bit 1

Setting this bit to a logic "1" clears all bytes in the RCVR FIFO and resets its counter logic to 0. The shift register is not cleared. This bit is self-clearing.

Bit 2

Setting this bit to a logic "1" clears all bytes in the XMIT FIFO and resets its counter logic to 0. The shift register is not cleared. This bit is self-clearing.

Bit 3

Writing to this bit has no effect on the operation of the UART. DMA modes are not supported in this chip.

Bit 4,5

Reserved

Bit 6,7

These bits are used to set the trigger level for the RCVR FIFO interrupt.

BIT 7	BIT 6	RCVR FIFO TRIGGER LEVEL (BYTES)
0	0	1
0	1	4
1	0	8
1	1	14

9.1.5 Interrupt Identification Register (IIR)

Address Offset = 2H, DLAB = X, READ

By accessing this register, the host CPU can determine the highest priority interrupt and its source. Four levels of priority interrupt exist. They are in descending order of priority:

1. Receiver Line Status (highest priority)
2. Received Data Ready

3. Transmitter Holding Register Empty
4. MODEM Status (lowest priority)

Information indicating that a prioritized interrupt is pending and the source of that interrupt is stored in the Interrupt Identification Register (refer to Interrupt Control Table). When the CPU accesses the IIR, the Serial Port freezes all interrupts and indicates the highest priority pending interrupt to the CPU. During this CPU access, even if the Serial Port records new interrupts, the current indication does not change until access is completed. The contents of the IIR are described below.

Bit 0

This bit can be used in either a hardwired prioritized or polled environment to indicate whether an interrupt is pending. When bit 0 is a logic "0", an interrupt is pending and the contents of the IIR may be used as a pointer to the appropriate internal service routine. When bit 0 is a logic "1", no interrupt is pending.

Bits 1 and 2

These two bits of the IIR are used to identify the highest priority interrupt pending as indicated by the Interrupt Control Table.

Bit 3

In non-FIFO mode, this bit is a logic "0". In FIFO mode this bit is set along with bit 2 when a timeout interrupt is pending.

Bits 4 and 5

These bits of the IIR are always logic "0".

Bits 6 and 7

These two bits are set when the FIFO CONTROL Register bit 0 equals 1.

Table 9.2 - Interrupt Control Table

FIFO MODE ONLY	INTERRUPT IDENTIFICATION REGISTER			INTERRUPT SET AND RESET FUNCTIONS			
	BIT 3	BIT 2	BIT 1	BIT 0	PRIORITY LEVEL	INTERRUPT TYPE	INTERRUPT SOURCE
0	0	0	1	-	None	None	-
0	1	1	0	Highest	Receiver Line Status	Overflow Error, Parity Error, Framing Error or Break Interrupt	Reading the Line Status Register
0	1	0	0	Second	Received Data Available	Receiver Data Available	Read Receiver Buffer or the FIFO drops below the trigger level.
1	1	0	0	Second	Character Timeout Indication	No Characters Have Been Removed From or Input to the RCVR FIFO during the last 4 Char times and there is at least 1 char in it during this	Reading the Receiver Buffer Register

FIFO MODE ONLY	INTERRUPT IDENTIFICATION REGISTER			INTERRUPT SET AND RESET FUNCTIONS				
	BIT 3	BIT 2	BIT 1	BIT 0	PRIORITY LEVEL	INTERRUPT TYPE	INTERRUPT SOURCE	INTERRUPT RESET CONTROL
							time	
0	0	1	0	Third	Transmitter Holding Register Empty	Transmitter Holding Register Empty	Reading the IIR Register (if Source of Interrupt) or Writing the Transmitter Holding Register	
0	0	0	0	Fourth	MODEM Status	Clear to Send or Data Set Ready or Ring Indicator or Data Carrier Detect	Reading the MODEM Status Register	

9.1.6 Line Control Register (LCR)

Address Offset = 3H, DLAB = 0, READ/WRITE

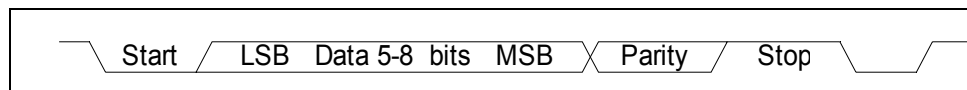

Figure 9.1 - Serial Data

This register contains the format information of the serial line. The bit definitions are:

Bits 0 and 1

These two bits specify the number of bits in each transmitted or received serial character. The encoding of bits 0 and 1 is as follows:

The Start, Stop and Parity bits are not included in the word length.

BIT 1	BIT 0	WORD LENGTH
0	0	5 Bits
0	1	6 Bits
1	0	7 Bits
1	1	8 Bits

Bit 2

This bit specifies the number of stop bits in each transmitted or received serial character. The following table summarizes the information.

BIT 2	WORD LENGTH	NUMBER OF STOP BITS
0	--	1
1	5 bits	1.5
1	6 bits	2
1	7 bits	2
1	8 bits	2

Note: The receiver will ignore all stop bits beyond the first, regardless of the number used in transmitting.

Bit 3

Parity Enable bit. When bit 3 is a logic "1", a parity bit is generated (transmit data) or checked (receive data) between the last data word bit and the first stop bit of the serial data. (The parity bit is used to generate an even or odd number of 1s when the data word bits and the parity bit are summed).

Bit 4

Even Parity Select bit. When bit 3 is a logic "1" and bit 4 is a logic "0", an odd number of logic "1"s is transmitted or checked in the data word bits and the parity bit. When bit 3 is a logic "1" and bit 4 is a logic "1" an even number of bits is transmitted and checked.

Bit 5

Stick Parity bit. When parity is enabled it is used in conjunction with bit 4 to select Mark or Space Parity. When LCR bits 3, 4 and 5 are 1 the Parity bit is transmitted and checked as 0 (Space Parity). If bits 3 and 5 are 1 and bit 4 is a 0, then the Parity bit is transmitted and checked as 1 (Mark Parity). If bit 5 is 0 Stick Parity is disabled.

Bit 6

Set Break Control bit. When bit 6 is a logic "1", the transmit data output (TXD) is forced to the Spacing or logic "0" state and remains there (until reset by a low level bit 6) regardless of other transmitter activity. This feature enables the Serial Port to alert a terminal in a communications system.

Bit 7

Divisor Latch Access bit (DLAB). It must be set high (logic "1") to access the Divisor Latches of the Baud Rate Generator during read or write operations. It must be set low (logic "0") to access the Receiver Buffer Register, the Transmitter Holding Register, or the Interrupt Enable Register.

9.1.7 Modem Control Register (MCR)

Address Offset = 4H, DLAB = X, READ/WRITE

This 8 bit register controls the interface with the MODEM or data set (or device emulating a MODEM). The contents of the MODEM control register are described below.

Bit 0

This bit controls the Data Terminal Ready (nDTR) output. When bit 0 is set to a logic "1", the nDTR output is forced to a logic "0". When bit 0 is a logic "0", the nDTR output is forced to a logic "1".

Bit 1

This bit controls the Request To Send (nRTS) output. Bit 1 affects the nRTS output in a manner identical to that described above for bit 0.

Bit 2

This bit controls the Output 1 (OUT1) bit. This bit does not have an output pin and can only be read or written by the CPU.

Bit 3

Output 2 (OUT2). This bit is used to enable an UART interrupt. When OUT2 is a logic "0", the serial port interrupt output is forced to a high impedance state - disabled. When OUT2 is a logic "1", the serial port interrupt outputs are enabled.

Bit 4

This bit provides the loopback feature for diagnostic testing of the Serial Port. When bit 4 is set to logic "1", the following occur:

1. The TXD is set to the Marking State(logic "1").
2. The receiver Serial Input (RXD) is disconnected.
3. The output of the Transmitter Shift Register is "looped back" into the Receiver Shift Register input.
4. All MODEM Control inputs (nCTS, nDSR, nRI and nDCD) are disconnected.
5. The four MODEM Control outputs (nDTR, nRTS, OUT1 and OUT2) are internally connected to the four MODEM Control inputs (nDSR, nCTS, RI, DCD).
6. The Modem Control output pins are forced inactive high.
7. Data that is transmitted is immediately received.

This feature allows the processor to verify the transmit and receive data paths of the Serial Port. In the diagnostic mode, the receiver and the transmitter interrupts are fully operational. The MODEM Control Interrupts are also operational but the interrupts' sources are now the lower four bits of the MODEM Control Register instead of the MODEM Control inputs. The interrupts are still controlled by the Interrupt Enable Register.

Bits 5 through 7

These bits are permanently set to logic zero.

9.1.8 Line Status Register (LSR)

Address Offset = 5H, DLAB = X, READ/WRITE

Bit 0

Data Ready (DR). It is set to a logic "1" whenever a complete incoming character has been received and transferred into the Receiver Buffer Register or the FIFO. Bit 0 is reset to a logic "0" by reading all of the data in the Receive Buffer Register or the FIFO.

Bit 1

Overrun Error (OE). Bit 1 indicates that data in the Receiver Buffer Register was not read before the next character was transferred into the register, thereby destroying the previous character. In FIFO mode, an overrun error will occur only when the FIFO is full and the next character has been completely received in the shift register, the character in the shift register is overwritten but not transferred to the FIFO. The OE indicator is set to a logic "1" immediately upon detection of an overrun condition, and reset whenever the Line Status Register is read.

Bit 2

Parity Error (PE). Bit 2 indicates that the received data character does not have the correct even or odd parity, as selected by the even parity select bit. The PE is set to a logic "1" upon detection of a parity error and is reset to a logic "0" whenever the Line Status Register is read. In the FIFO mode this error is associated with the particular character in the FIFO it applies to. This error is indicated when the associated character is at the top of the FIFO.

Bit 3

Framing Error (FE). Bit 3 indicates that the received character did not have a valid stop bit. Bit 3 is set to a logic "1" whenever the stop bit following the last data bit or parity bit is detected as a zero bit (Spacing level). The FE is reset to a logic "0" whenever the Line Status Register is read. In the FIFO mode this error is associated with the particular character in the FIFO it applies to. This error is indicated when the associated character is at the top of the FIFO. The Serial Port will try to resynchronize after a framing error. To do this, it assumes that the framing error was due to the next start bit, so it samples this 'start' bit twice and then takes in the 'data'.

Bit 4

Break Interrupt (BI). Bit 4 is set to a logic "1" whenever the received data input is held in the Spacing state (logic "0") for longer than a full word transmission time (that is, the total time of the start bit + data bits + parity bits + stop bits). The BI is reset after the CPU reads the contents of the Line Status Register. In the FIFO mode this error is associated with the particular character in the FIFO it applies to. This error is indicated when the associated character is at the top of the FIFO. When break occurs only one zero character is loaded into the FIFO. Restarting after a break is received, requires the serial data (RXD) to be logic "1" for at least 1/2 bit time.

Note: Bits 1 through 4 are the error conditions that produce a Receiver Line Status Interrupt whenever any of the corresponding conditions are detected and the interrupt is enabled.

Bit 5

Transmitter Holding Register Empty (THRE). Bit 5 indicates that the Serial Port is ready to accept a new character for transmission. In addition, this bit causes the Serial Port to issue an interrupt when the Transmitter Holding Register interrupt enable is set high. The THRE bit is set to a logic "1" when a character is transferred from the Transmitter Holding Register into the Transmitter Shift Register. The bit is reset to logic "0" whenever the CPU loads the Transmitter Holding Register. In the FIFO mode this bit is



set when the XMIT FIFO is empty, it is cleared when at least 1 byte is written to the XMIT FIFO. Bit 5 is a read only bit.

Bit 6

Transmitter Empty (TEMT). Bit 6 is set to a logic "1" whenever the Transmitter Holding Register (THR) and Transmitter Shift Register (TSR) are both empty. It is reset to logic "0" whenever either the THR or TSR contains a data character. Bit 6 is a read only bit. In the FIFO mode this bit is set whenever the THR and TSR are both empty.

Bit 7

This bit is permanently set to logic "0" in the 450 mode. In the FIFO mode, this bit is set to a logic "1" when there is at least one parity error, framing error or break indication in the FIFO. This bit is cleared when the LSR is read if there are no subsequent errors in the FIFO.

9.1.9 Modem Status Register (MSR)

Address Offset = 6H, DLAB = X, READ/WRITE

This 8 bit register provides the current state of the control lines from the MODEM (or peripheral device). In addition to this current state information, four bits of the MODEM Status Register (MSR) provide change information. These bits are set to logic "1" whenever a control input from the MODEM changes state. They are reset to logic "0" whenever the MODEM Status Register is read.

Bit 0

Delta Clear To Send (DCTS). Bit 0 indicates that the nCTS input to the chip has changed state since the last time the MSR was read.

Bit 1

Delta Data Set Ready (DDSR). Bit 1 indicates that the nDSR input has changed state since the last time the MSR was read.

Bit 2

Trailing Edge of Ring Indicator (TERI). Bit 2 indicates that the nRI input has changed from logic "0" to logic "1".

Bit 3

Delta Data Carrier Detect (DDCD). Bit 3 indicates that the nDCD input to the chip has changed state.

Note: Whenever bit 0, 1, 2, or 3 is set to a logic "1", a MODEM Status Interrupt is generated.

Bit 4

This bit is the complement of the Clear To Send (nCTS) input. If bit 4 of the MCR is set to logic "1", this bit is equivalent to nRTS in the MCR.

Bit 5

This bit is the complement of the Data Set Ready (nDSR) input. If bit 4 of the MCR is set to logic "1", this bit is equivalent to DTR in the MCR.

Bit 6

This bit is the complement of the Ring Indicator (nRI) input. If bit 4 of the MCR is set to logic "1", this bit is equivalent to OUT1 in the MCR.

Bit 7

This bit is the complement of the Data Carrier Detect (nDCD) input. If bit 4 of the MCR is set to logic "1", this bit is equivalent to OUT2 in the MCR.

9.1.10 Scratchpad Register (SCR)

Address Offset =7H, DLAB =X, READ/WRITE

This 8 bit read/write register has no effect on the operation of the Serial Port. It is intended as a scratchpad register to be used by the programmer to hold data temporarily.

9.2 Programmable Baud Rate Generator (AND Divisor Latches DLH, DLL)

The Serial Port contains a programmable Baud Rate Generator that is capable of dividing the internal PLL clock by any divisor from 1 to 65535. The internal PLL clock is divided down to generate a 1.8462MHz frequency for Baud Rates less than 38.4k, a 1.8432MHz frequency for 115.2k, a 3.6864MHz frequency for 230.4k and a 7.3728MHz frequency for 460.8k. This output frequency of the Baud Rate Generator is 16x the Baud rate. Two 8 bit latches store the divisor in 16 bit binary format. These Divisor Latches must be loaded during initialization in order to insure desired operation of the Baud Rate Generator. Upon loading either of the Divisor Latches, a 16 bit Baud counter is immediately loaded. This prevents long counts on initial load. If a 0 is loaded into the BRG registers the output divides the clock by the number 3. If a 1 is loaded the output is the inverse of the input oscillator. If a two is loaded the output is a divide by 2 signal with a 50% duty cycle. If a 3 or greater is loaded the output is low for 2 bits and high for the remainder of the count. The input clock to the BRG is a 1.8462 MHz clock.

Table 9.3 shows the baud rates possible.

9.3 Effect Of The Reset on Register File

The Reset Function Table (Table 9.4) details the effect of the Reset input on each of the registers of the Serial Port.

9.4 FIFO Interrupt Mode Operation

When the RCVR FIFO and receiver interrupts are enabled (FCR bit 0 = "1", IER bit 0 = "1"), RCVR interrupts occur as follows:

- A) The receive data available interrupt will be issued when the FIFO has reached its programmed trigger level; it is cleared as soon as the FIFO drops below its programmed trigger level.
- B) The IIR receive data available indication also occurs when the FIFO trigger level is reached. It is cleared when the FIFO drops below the trigger level.
- C) The receiver line status interrupt (IIR=06H), has higher priority than the received data available (IIR=04H) interrupt.
- D) The data ready bit (LSR bit 0) is set as soon as a character is transferred from the shift register to the RCVR FIFO. It is reset when the FIFO is empty.

When RCVR FIFO and receiver interrupts are enabled, RCVR FIFO timeout interrupts occur as follows:

- A) A FIFO timeout interrupt occurs if all the following conditions exist:

At least one character is in the FIFO.

The most recent serial character received was longer than 4 continuous character times ago. (If 2 stop bits are programmed, the second one is included in this time delay).

The most recent CPU read of the FIFO was longer than 4 continuous character times ago.

This will cause a maximum character received to interrupt issued delay of 160 msec at 300 BAUD with a 12 bit character.

- B) Character times are calculated by using the RCLK input for a clock signal (this makes the delay proportional to the baud rate).
- C) When a timeout interrupt has occurred it is cleared and the timer reset when the CPU reads one character from the RCVR FIFO.
- D) When a timeout interrupt has not occurred the timeout timer is reset after a new character is received or after the CPU reads the RCVR FIFO.

When the XMIT FIFO and transmitter interrupts are enabled (FCR bit 1 = "1", IER bit 1 = "1"), XMIT interrupts occur as follows:

- A) The transmitter holding register interrupt (02H) occurs when the XMIT FIFO is empty; it is cleared as soon as the transmitter holding register is written to (1 of 16 characters may be written to the XMIT FIFO while servicing this interrupt) or the IIR is read.
- B) The transmitter FIFO empty indications will be delayed 1 character time minus the last stop bit time whenever the following occurs: THRE=1 and there have not been at least two bytes at the same time in the transmitter FIFO since the last THRE=1. The transmitter interrupt after changing FCR0 will be immediate, if it is enabled.

Character timeout and RCVR FIFO trigger level interrupts have the same priority as the current received data available interrupt; XMIT FIFO empty has the same priority as the current transmitter holding register empty interrupt.

9.5 FIFO Polled Mode Operation

With FCR bit 0 = "1" resetting IER bits 0, 1, 2 or 3 or all to zero puts the UART in the FIFO Polled Mode of operation. Since the RCVR and XMITTER are controlled separately, either one or both can be in the polled mode of operation. In this mode, the user's program will check RCVR and XMITTER status via the LSR. LSR definitions for the FIFO Polled Mode are as follows:

Bit 0=1 as long as there is one byte in the RCVR FIFO.

Bits 1 to 4 specify which error(s) have occurred. Character error status is handled the same way as when in the interrupt mode, the IIR is not affected since EIR bit 2=0.

Bit 5 indicates when the XMIT FIFO is empty.

Bit 6 indicates that both the XMIT FIFO and shift register are empty.

Bit 7 indicates whether there are any errors in the RCVR FIFO.

There is no trigger level reached or timeout condition indicated in the FIFO Polled Mode, however, the RCVR and XMIT FIFOs are still fully capable of holding characters.

Table 9.3 - Baud Rates

DESIRED BAUD RATE	DIVISOR USED TO GENERATE 16X CLOCK	PERCENT ERROR DIFFERENCE BETWEEN DESIRED AND ACTUAL (NOTE 9.2)	HIGH SPEED BIT (NOTE 9.3)
50	2304	0.001	X
75	1536	-	X
110	1047	-	X
134.5	857	0.004	X
150	768	-	X
300	384	-	X
600	192	-	X
1200	96	-	X
1800	64	-	X
2000	58	0.005	X
2400	48	-	X
3600	32	-	X
4800	24	-	X
7200	16	-	X
9600	12	-	X
19200	6	-	X
38400	3	0.030	X
57600	2	0.16	X
115200	1	0.16	X
230400	32770	0.16	1
460800	32769	0.16	1

Note 9.2 The percentage error for all baud rates, except where indicated otherwise, is 0.2%.

Note 9.3 The High Speed bit is located in the Device Configuration Space.

Table 9.4 - Reset Function Table

REGISTER/SIGNAL	RESET CONTROL	RESET STATE
Interrupt Enable Register	RESET	All bits low
Interrupt Identification Reg.	RESET	Bit 0 is high; Bits 1 - 7 low
FIFO Control	RESET	All bits low
Line Control Reg.	RESET	All bits low
MODEM Control Reg.	RESET	All bits low
Line Status Reg.	RESET	All bits low except 5, 6 high
MODEM Status Reg.	RESET	Bits 0 - 3 low; Bits 4 - 7 input
TXD1	RESET	High
INTRPT (RCVR errs)	RESET/Read LSR	Low
INTRPT (RCVR Data Ready)	RESET/Read RBR	Low
INTRPT (THRE)	RESET/ReadIIR/Write THR	Low
OUT2B	RESET	High
RTSB	RESET	High
DTRB	RESET	High
OUT1B	RESET	High
RCVR FIFO	RESET/ FCR1*FCR0/_FCR0	All Bits Low
XMIT FIFO	RESET/ FCR1*FCR0/_FCR0	All Bits Low

Table 9.5 - Register Summary for an Individual UART Channel

REGISTER ADDRESS (Note 9.4)	REGISTER NAME	REGISTER SYMBOL	BIT 7	BIT 6	BIT 5	BIT 4	BIT 3	BIT 2	BIT 1	BIT 0
ADDR = 0 DLAB = 0	Receive Buffer Register (Read Only)	RBR	Data Bit 7	Data Bit 6	Data Bit 5	Data Bit 4	Data Bit 3	Data Bit 2	Data Bit 1	Data Bit 0 (Note 9.5)
ADDR = 0 DLAB = 0	Transmitter Holding Register (Write Only)	THR	Data Bit 7	Data Bit 6	Data Bit 5	Data Bit 4	Data Bit 3	Data Bit 2	Data Bit 1	Data Bit 0
ADDR = 1 DLAB = 0	Interrupt Enable Register	IER	0	0	0	0	Enable MODEM Status Interrupt (EMSI)	Enable Receiver Line Status Interrupt (ELSI)	Enable Transmitter Holding Register Empty Interrupt (ETHREI)	Enable Received Data Available Interrupt (ERDAI)
ADDR = 2	Interrupt Ident. Register (Read Only)	IIR	FIFOs Enabled (Note 9.9)	FIFOs Enabled (Note 9.9)	0	0	Interrupt ID Bit (Note 9.9)	Interrupt ID Bit	Interrupt ID Bit	"0" if Interrupt Pending
ADDR = 2	FIFO Control Register (Write Only)	FCR (Note 9.11)	RCVR Trigger MSB	RCVR Trigger LSB	Reserved	Reserved	DMA Mode Select (Note 9.10)	XMIT FIFO Reset	RCVR FIFO Reset	FIFO Enable
ADDR = 3	Line Control Register	LCR	Divisor Latch Access Bit (DLAB)	Set Break	Stick Parity	Even Parity Select (EPS)	Parity Enable (PEN)	Number of Stop Bits (STB)	Word Length Select Bit 1 (WLS1)	Word Length Select Bit 0 (WLS0)
ADDR = 4	MODEM Control Register	MCR	0	0	0	Loop	OUT2 (Note 9.7)	OUT1 (Note 9.7)	Request to Send (RTS)	Data Terminal Ready (DTR)
ADDR = 5	Line Status Register	LSR	Error in RCVR FIFO (Note 9.9)	Transmitter Empty (TEMT) (Note 9.6)	Transmitter Holding Register (THRE)	Break Interrupt (BI)	Framing Error (FE)	Parity Error (PE)	Overrun Error (OE)	Data Ready (DR)
ADDR = 6	MODEM Status Register	MSR	Data Carrier Detect (DCD)	Ring Indicator (RI)	Data Set Ready (DSR)	Clear to Send (CTS)	Delta Data Carrier Detect (DDCD)	Trailing Edge Ring Indicator (TERI)	Delta Data Set Ready (DDSR)	Delta Clear to Send (DCTS)
ADDR = 7	Scratch Register (Note 9.8)	SCR	Bit 7	Bit 6	Bit 5	Bit 4	Bit 3	Bit 2	Bit 1	Bit 0
ADDR = 0 DLAB = 1	Divisor Latch (L-S)	DDL	Bit 7	Bit 6	Bit 5	Bit 4	Bit 3	Bit 2	Bit 1	Bit 0
ADDR = 1 DLAB = 1	Divisor Latch (MS)	DLM	Bit 15	Bit 14	Bit 13	Bit 12	Bit 11	Bit 10	Bit 9	Bit 8



Note 9.4 DLAB is Bit 7 of the Line Control Register (ADDR = 3).

Note 9.5 Bit 0 is the least significant bit. It is the first bit serially transmitted or received.

Note 9.6 When operating in the XT mode, this bit will be set any time that the transmitter shift register is empty.

Note 9.7 This bit no longer has a pin associated with it.

Note 9.8 When operating in the XT mode, this register is not available.

Note 9.9 These bits are always zero in the non-FIFO mode.

Note 9.10 Writing a one to this bit has no effect. DMA modes are not supported in this chip.

Note 9.11 The UART1 and UART2 FCR's are shadowed in the UART1 FIFO Control Shadow Register (runtime register at offset 0x20) and UART2 FIFO Control Shadow Register (runtime register at offset 0x21).

9.6 Notes On Serial Port Operation

9.6.1 FIFO Mode Operation

GENERAL

The RCVR FIFO will hold up to 16 bytes regardless of which trigger level is selected.

9.6.2 TX AND RX FIFO Operation

The Tx portion of the UART transmits data through TXD as soon as the CPU loads a byte into the Tx FIFO. **The UART will prevent loads to the Tx FIFO if it currently holds 16 characters.** Loading to the Tx FIFO will again be enabled as soon as the next character is transferred to the Tx shift register. These capabilities account for the largely autonomous operation of the Tx.

The UART starts the above operations typically with a Tx interrupt. The chip issues a Tx interrupt whenever the Tx FIFO is empty and the Tx interrupt is enabled, except in the following instance. Assume that the Tx FIFO is empty and the CPU starts to load it. When the first byte enters the FIFO the Tx FIFO empty interrupt will transition from active to inactive. Depending on the execution speed of the service routine software, the UART may be able to transfer this byte from the FIFO to the shift register before the CPU loads another byte. If this happens, the Tx FIFO will be empty again and typically the UART's interrupt line would transition to the active state. This could cause a system with an interrupt control unit to record a Tx FIFO empty condition, even though the CPU is currently servicing that interrupt. **Therefore, after the first byte has been loaded into the FIFO the UART will wait one serial character transmission time before issuing a new Tx FIFO empty interrupt. This one character Tx interrupt delay will remain active until at least two bytes have been loaded into the FIFO, concurrently. When the Tx FIFO empties after this condition, the Tx interrupt will be activated without a one character delay.**

Rx support functions and operation are quite different from those described for the transmitter. The Rx FIFO receives data until the number of bytes in the FIFO equals the selected interrupt trigger level. At that time if Rx interrupts are enabled, the UART will issue an interrupt to the CPU. The Rx FIFO will continue to store bytes until it holds 16 of them. It will not accept any more data when it is full. Any more data entering the Rx shift register will set the Overrun Error flag. Normally, the FIFO depth and the programmable trigger levels will give the CPU ample time to empty the Rx FIFO before an overrun occurs.

One side-effect of having a Rx FIFO is that the selected interrupt trigger level may be above the data level in the FIFO. This could occur when data at the end of the block contains fewer bytes than the trigger level. No interrupt would be issued to the CPU and the data would remain in the UART. **To prevent the software from having to check for this situation the chip incorporates a timeout interrupt.**

The timeout interrupt is activated when there is a least one byte in the Rx FIFO, and neither the CPU nor the Rx shift register has accessed the Rx FIFO within 4 character times of the last byte. The timeout interrupt is cleared or reset when the CPU reads the Rx FIFO or another character enters it.

These FIFO related features allow optimization of CPU/UART transactions and are especially useful given the higher baud rate capability (256 kbaud).

Chapter 10 Infrared Interface

The LPC47N217 infrared interface provides a two-way wireless communications port using infrared as the transmission medium. Several infrared protocols have been provided in this implementation including IrDA v1.2 (SIR/FIR), ASKIR, and Consumer IR (Figure 10.1- Infrared Interface Block Diagram). For more information consult the SMSC Infrared Communication Controller (IRCC 2.0) specification.

The IrDA v1.0 (SIR) and ASKIR formats are driven by the ACE registers found in UART2. The UART2 registers are described in Chapter 9 - Serial Port (UART). The base address for UART2 is programmed in CR25, the UART2 Base Address Register (see section CR25 subsection in the Configuration section).

The IrDA V1.2 (FIR) and Consumer IR formats are driven by the SCE registers. Descriptions of these registers can be found in the SMSC Infrared Communications Controller Specification. The Base Address for the SCE registers is programmed in CR2B, the SCE Base Address Register (see CR28 subsection in the Configuration section).

10.1 IrDA SIR/FIR and ASKIR

IrDA SIR (v1.0) specifies asynchronous serial communication at baud rates up to 115.2Kbps. Each byte is sent serially LSB first beginning with a zero value start bit. A zero is signaled by sending a single infrared pulse at the beginning of the serial bit time. A one is signaled by the absence of an infrared pulse during the bit time. Please refer to Chapter 21 - Timing Diagrams for the parameters of these pulses and the IrDA waveforms.

IrDA FIR (v1.2) includes IrDA v1.0 SIR and additionally specifies synchronous serial communications at data rates up to 4Mbps.

Data is transferred LSB first in packets that can be up to 2048 bits in length. IrDA v1.2 includes .576Mbps and 1.152Mbps data rates using an encoding scheme that is similar to SIR. The 4Mbps data rate uses a pulse position modulation (PPM) technique.

The ASKIR infrared allows asynchronous serial communication at baud rates up to 19.2Kbps. Each byte is sent serially LSB first beginning with a zero value start bit. A zero is signaled by sending a 500KHz carrier waveform for the duration of the serial bit time. A one is signaled by the absence of carrier during the bit time. Refer to the Timing Diagrams section for the parameters of the ASKIR waveforms.

10.2 Consumer IR

The LPC47N217 Consumer IR interface is a general-purpose Amplitude Shift Keyed encoder/decoder with programmable carrier and bit-cell rates that can emulate many popular TV Remote encoding formats; including, 38KHz PPM, PWM and RC-5. The carrier frequency is programmable from 1.6MHz to 6.25KHz. The bit-cell rate range is 100KHz to 390Hz.

10.3 Hardware Interface

The LPC47N217 IR hardware interface is shown in Figure 10.1. This interface supports two types of external FIR transceiver modules. One uses a mode pin (IR Mode) to program the data rate, while the other has a second Rx data pin (IRRX3). The LPC47N217 uses Pin 63 for these functions. Pin 63 has IR Mode and IRRX3 as its first and second alternate function, respectively. These functions are selected through CR29 as shown in Table 10.1.

Table 10.1 - FIR Transceiver Module-Type Select

HP MODE (NOTE 10.1)	FUNCTION
0	IR Mode
1	IRRX3

Note 10.1 HPMODE is CR29, BIT 4 (see CR29 subsection in the Configuration section). Refer to the Infrared Interface Block Diagram on the following page for HPMODE implementation.

The FAST bit is used to select between the SIR mode and FIR mode receiver, regardless of the transceiver type. If FAST = 1, the FIR mode receiver is selected; if FAST = 0, the SIR mode receiver is selected (Table 10.2).

Table 10.2 - IR Rx Data Pin Selection

CONTROL SIGNALS		INPUTS	
FAST	HPMODE	RX1	RX2
0	X	RX1=RXD2	RX2=IRRX2
X	0	RX1=RXD2	RX2=IRRX2
1	1	RX1=IR Mode/IRRX3	RX2=IR Mode/IRRX3

10.4 IR Half Duplex Turnaround Delay Time

If the Half Duplex option is chosen there is an IR Half Duplex Time-out that constrains IRCC direction mode changes. This time-out starts as each bit is transferred and prevents direction mode changes until the time-out expires. The timer is restarted whenever new data arrives in the current direction mode. For example, if data is loaded into the transmit buffer while a character is being received, the transmission will not start until the last bit has been received and the time-out expires. If the start bit of another character is received during this time-out, the timer is restarted after the new character is received. The Half Duplex Time-out is programmable from 0 to 25.5ms in 100µs increments (see subsection CR2D in the Configuration section).

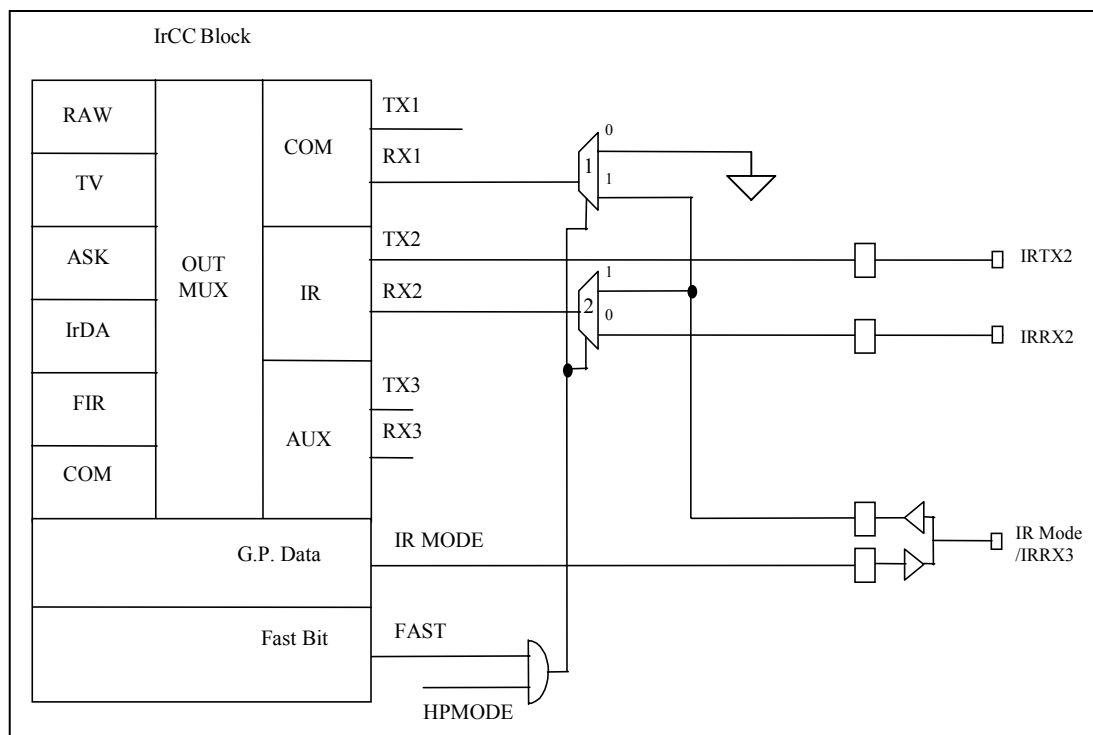

Figure 10.1 - Infrared Interface Block Diagram

10.5 IR Transmit Pins

The IRTX2 pin defaults to output, low on VCC POR and hard reset. This pin is not powered by VTR. This pin functions as described below.

Following a VCC POR, the IRTX2 pins will be output and low. They will remain low until one of the following conditions are met.

IRTX2 Pin (CR0A bits [7:6]=01):

- This pin will remain low following a VCC POR until serial port 2 is enabled by setting the UART2 power down bit (CR02, bit 7), at which time the pin will reflect the state of the IR transmit output of the IRCC block (if IR is enabled through the IR Option Register for Serial Port 2).

The IRTX2 pin will be driven low whenever serial port 2 is disabled (UART2 power down bit is cleared).

Note that bits[7,6] of CR0A can be used to override this functionality of driving the IRTX2 pin low when UART2 is powered down. If these bit are set to '11', then the IRTX2 pin is high-z.

Chapter 11 Parallel Port

The LPC47N217 incorporates an IBM XT/AT compatible parallel port. This supports the optional PS/2 type bi-directional parallel port (SPP), the Enhanced Parallel Port (EPP) and the Extended Capabilities Port (ECP) parallel port modes. Refer to the Configuration Registers for information on disabling, power down, changing the base address of the parallel port, and selecting the mode of operation.

The parallel port also incorporates SMSC's ChiProtect circuitry, which prevents possible damage to the parallel port due to printer power-up.

The functionality of the Parallel Port is achieved through the use of eight addressable ports, with their associated registers and control gating. The control and data port are read/write by the CPU, the status port is read/write in the EPP mode. The address map of the Parallel Port is shown below

DATA PORT	BASE ADDRESS + 00H
STATUS PORT	BASE ADDRESS + 01H
CONTROL PORT	BASE ADDRESS + 02H
EPP ADDR PORT	BASE ADDRESS + 03H
EPP DATA PORT 0	BASE ADDRESS + 04H
EPP DATA PORT 1	BASE ADDRESS + 05H
EPP DATA PORT 2	BASE ADDRESS + 06H
EPP DATA PORT 3	BASE ADDRESS + 07H

The bit map of these registers is:

	D0	D1	D2	D3	D4	D5	D6	D7	NOTE
DATA PORT	PD0	PD1	PD2	PD3	PD4	PD5	PD6	PD7	Note 11.1
STATUS PORT	TMOUT	0	0	nERR	SLCT	PE	nACK	nBUSY	Note 11.1
CONTROL PORT	STROBE	AUTOFD	nINIT	SLC	IRQE	PCD	0	0	Note 11.1
EPP ADDR PORT	PD0	PD1	PD2	PD3	PD4	PD5	PD6	PD7	Note 11.2
EPP DATA PORT 0	PD0	PD1	PD2	PD3	PD4	PD5	PD6	PD7	Note 11.2
EPP DATA PORT 1	PD0	PD1	PD2	PD3	PD4	PD5	PD6	PD7	Note 11.2
EPP DATA PORT 2	PD0	PD1	PD2	PD3	PD4	PD5	PD6	PD7	Note 11.2
EPP DATA PORT 3	PD0	PD1	PD2	PD3	PD4	PD5	PD6	PD7	Note 11.2

Note 11.1 These registers are available in all modes.

Note 11.2 These registers are only available in EPP mode.

Table 11.1 - Parallel Port Connector

HOST CONNECTOR	PIN NUMBER	STANDARD	EPP	ECP
1	83	nSTROBE	nWrite	nStrobe
2-9	68-75	PD<0:7>	PData<0:7>	PData<0:7>
10	80	nACK	Intr	nAck
11	79	BUSY	nWait	Busy, PeriphAck(3)
12	78	PE	(User Defined)	PError, nAckReverse(3)
13	77	SLCT	(User Defined)	Select

HOST CONNECTOR	PIN NUMBER	STANDARD	EPP	ECP
14	82	nALF	nDataStb	nAutoFd, HostAck(3)
15	81	nERROR	(User Defined)	nFault(1) nPeriphRequest(3)
16	66	nINIT	nRESET	nInit(1) nReverseRqst(3)
17	67	nSLCTIN	nAddrstrb	nSelectIn(1,3)
(1) = Compatible Mode				
(3) = High Speed Mode				

Note: For the cable interconnection required for ECP support and the Slave Connector pin numbers, refer to the IEEE 1284 Extended Capabilities Port Protocol and ISA Standard, Rev. 1.14, July 14, 1993. This document is available from Microsoft.

11.1 IBM XT/AT Compatible, Bi-Directional And EPP Modes

11.1.1 Data Port

ADDRESS OFFSET = 00H

The Data Port is located at an offset of '00H' from the base address. The data register is cleared at initialization by RESET. During a WRITE operation, the Data Register latches the contents of the internal data bus. The contents of this register are buffered (non inverting) and output onto the PD0 - PD7 ports. During a READ operation in SPP mode, PD0 - PD7 ports are buffered (not latched) and output to the host CPU.

11.1.2 Status Port

ADDRESS OFFSET = 01H

The Status Port is located at an offset of '01H' from the base address. The contents of this register are latched for the duration of a read cycle. The bits of the Status Port are defined as follows:

BIT 0 TMOUT - TIME OUT

This bit is valid in EPP mode only and indicates that a 10 usec time out has occurred on the EPP bus. A logic zero means that no time out error has occurred; a logic 1 means that a time out error has been detected.

The means of clearing the TIMEOUT bit is controlled by the TIMEOUT_SELECT bit as follows. The TIMEOUT_SELECT bit is located at bit 2 of CR21.

- If the TIMEOUT_SELECT bit is cleared ('0'), the TIMEOUT bit is cleared on the trailing edge of the read of the EPP Status Register (default)
- If the TIMEOUT_SELECT bit is set ('1'), the TIMEOUT bit is cleared on a write of '1' to the TIMEOUT bit.

The TIMEOUT bit is cleared on PCI_RESET regardless of the state of the TIMEOUT_SELECT bit.



BITS 1, 2 - are not implemented as register bits, during a read of the Printer Status Register these bits are a low level.

BIT 3 nERR - nERROR

The level on the nERROR input is read by the CPU as bit 3 of the Printer Status Register. A logic 0 means an error has been detected; a logic 1 means no error has been detected.

BIT 4 SLCT - PRINTER SELECTED STATUS

The level on the SLCT input is read by the CPU as bit 4 of the Printer Status Register. A logic 1 means the printer is on line; a logic 0 means it is not selected.

BIT 5 PE - PAPER END

The level on the PE input is read by the CPU as bit 5 of the Printer Status Register. A logic 1 indicates a paper end; a logic 0 indicates the presence of paper.

BIT 6 nACK - nACKNOWLEDGE

The level on the nACK input is read by the CPU as bit 6 of the Printer Status Register. A logic 0 means that the printer has received a character and can now accept another. A logic 1 means that it is still processing the last character or has not received the data.

BIT 7 nBUSY - nBUSY

The complement of the level on the BUSY input is read by the CPU as bit 7 of the Printer Status Register. A logic 0 in this bit means that the printer is busy and cannot accept a new character. A logic 1 means that it is ready to accept the next character.

11.1.3 Control Port

ADDRESS OFFSET = 02H

The Control Port is located at an offset of '02H' from the base address. The Control Register is initialized by the RESET input, bits 0 to 5 only being affected; bits 6 and 7 are hard wired low.

BIT 0 STROBE - STROBE

This bit is inverted and output onto the nSTROBE output.

BIT 1 AUTOFD - AUTOFEED

This bit is inverted and output onto the nAUTOFD output. A logic 1 causes the printer to generate a line feed after each line is printed. A logic 0 means no autofeed.

BIT 2 nINIT - nINITIATE OUTPUT

This bit is output onto the nINIT output without inversion.

BIT 3 SLCTIN - PRINTER SELECT INPUT

This bit is inverted and output onto the nSLCTIN output. A logic 1 on this bit selects the printer; a logic 0 means the printer is not selected.

BIT 4 IRQE - INTERRUPT REQUEST ENABLE

The interrupt request enable bit when set to a high level may be used to enable interrupt requests from the Parallel Port to the CPU. An interrupt request is generated on the IRQ port by a positive going nACK input. When the IRQE bit is programmed low the IRQ is disabled.

BIT 5 PCD - PARALLEL CONTROL DIRECTION

Parallel Control Direction is not valid in printer mode. In printer mode, the direction is always out regardless of the state of this bit. In bi-directional, EPP or ECP mode, a logic 0 means that the printer port is in output mode (write); a logic 1 means that the printer port is in input mode (read).

Bits 6 and 7 during a read are a low level, and cannot be written.

11.1.4 EPP Address Port

ADDRESS OFFSET = 03H

The EPP Address Port is located at an offset of '03H' from the base address. The address register is cleared at initialization by RESET. During a WRITE operation, the contents of the internal data bus DB0-DB7 are buffered (non inverting) and output onto the PD0 - PD7 ports. An LPC I/O write cycle causes an EPP ADDRESS WRITE cycle to be performed, during which the data is latched for the duration of the EPP write cycle. During a READ operation, PD0 - PD7 ports are read. An LPC I/O read cycle causes an EPP ADDRESS READ cycle to be performed and the data output to the host CPU, the deassertion of ADDRSTB latches the PData for the duration of the read cycle. This register is only available in EPP mode.

11.1.5 EPP Data Port 0

ADDRESS OFFSET = 04H

The EPP Data Port 0 is located at an offset of '04H' from the base address. The data register is cleared at initialization by RESET. During a WRITE operation, the contents of the internal data bus DB0-DB7 are buffered (non inverting) and output onto the PD0 - PD7 ports. An LPC I/O write cycle causes an EPP DATA WRITE cycle to be performed, during which the data is latched for the duration of the EPP write cycle. During a READ operation, PD0 - PD7 ports are read. An LPC I/O read cycle causes an EPP READ cycle to be performed and the data output to the host CPU, the deassertion of DATASTB latches the PData for the duration of the read cycle. This register is only available in EPP mode.

11.1.6 EPP Data Port 1

ADDRESS OFFSET = 05H

The EPP Data Port 1 is located at an offset of '05H' from the base address. Refer to EPP DATA PORT 0 for a description of operation. This register is only available in EPP mode.

11.1.7 EPP Data Port 2

ADDRESS OFFSET = 06H

The EPP Data Port 2 is located at an offset of '06H' from the base address. Refer to EPP DATA PORT 0 for a description of operation. This register is only available in EPP mode.

11.1.8 EPP Data Port 3

ADDRESS OFFSET = 07H

The EPP Data Port 3 is located at an offset of '07H' from the base address. Refer to EPP DATA PORT 0 for a description of operation. This register is only available in EPP mode.

11.2 EPP 1.9 Operation

When the EPP mode is selected in the configuration register, the standard and bi-directional modes are also available. If no EPP Read, Write or Address cycle is currently executing, then the PDx bus is in the standard or bi-directional mode, and all output signals (STROBE, AUTOFD, INIT) are as set by the SPP Control Port and direction is controlled by PCD of the Control port.

In EPP mode, the system timing is closely coupled to the EPP timing. For this reason, a watchdog timer is required to prevent system lockup. The timer indicates if more than 10usec have elapsed from the start of the EPP cycle to nWAIT being deasserted (after command). If a time-out occurs, the current EPP cycle is aborted and the time-out condition is indicated in Status bit 0.

During an EPP cycle, if STROBE is active, it overrides the EPP write signal forcing the PDx bus to always be in a write mode and the nWRITE signal to always be asserted.

11.2.1 Software Constraints

Before an EPP cycle is executed, the software must ensure that the control register bit PCD is a logic "0" (i.e., a 04H or 05H should be written to the Control port). If the user leaves PCD as a logic "1", and attempts to perform an EPP write, the chip is unable to perform the write (because PCD is a logic "1") and will appear to perform an EPP read on the parallel bus, no error is indicated.

11.2.2 EPP 1.9 Write

The timing for a write operation (address or data) is shown in timing diagram EPP Write Data or Address cycle. The chip inserts wait states into the LPC I/O write cycle until it has been determined that the write cycle can complete. The write cycle can complete under the following circumstances:

1. If the EPP bus is not ready (nWAIT is active low) when nDATASTB or nADDRSTB goes active then the write can complete when nWAIT goes inactive high.
2. If the EPP bus is ready (nWAIT is inactive high) then the chip must wait for it to go active low before changing the state of nDATASTB, nWRITE or nADDRSTB. The write can complete once nWAIT is determined inactive.

Write Sequence of operation

1. The host initiates an I/O write cycle to the selected EPP register.
2. If WAIT is not asserted, the chip must wait until WAIT is asserted.
3. The chip places address or data on PData bus, clears PDIR, and asserts nWRITE.

4. Chip asserts nDATASTB or nADDRSTRB indicating that PData bus contains valid information, and the WRITE signal is valid.
5. Peripheral deasserts nWAIT, indicating that any setup requirements have been satisfied and the chip may begin the termination phase of the cycle.
6.
 - a) The chip deasserts nDATASTB or nADDRSTRB, this marks the beginning of the termination phase. If it has not already done so, the peripheral should latch the information byte now.
 - b) The chip latches the data from the internal data bus for the PData bus and drives the sync that indicates that no more wait states are required followed by the TAR to complete the write cycle.
7. Peripheral asserts nWAIT, indicating to the host that any hold time requirements have been satisfied and acknowledging the termination of the cycle.
8. Chip may modify nWRITE and nPDATA in preparation for the next cycle.

11.2.3 EPP 1.9 Read

The timing for a read operation (data) is shown in timing diagram EPP Read Data cycle. The chip inserts wait states into the LPC I/O read cycle until it has been determined that the read cycle can complete. The read cycle can complete under the following circumstances:

1. If the EPP bus is not ready (nWAIT is active low) when nDATASTB goes active then the read can complete when nWAIT goes inactive high.
2. If the EPP bus is ready (nWAIT is inactive high) then the chip must wait for it to go active low before changing the state of WRITE or before nDATASTB goes active. The read can complete once nWAIT is determined inactive.

Read Sequence of Operation

1. The host initiates an I/O read cycle to the selected EPP register.
2. If WAIT is not asserted, the chip must wait until WAIT is asserted.
3. The chip tri-states the PData bus and deasserts nWRITE.
4. Chip asserts nDATASTB or nADDRSTRB indicating that PData bus is tri-stated, PDIR is set and the nWRITE signal is valid.
5. Peripheral drives PData bus valid.
6. Peripheral deasserts nWAIT, indicating that PData is valid and the chip may begin the termination phase of the cycle.
 - a) The chip latches the data from the PData bus for the internal data bus and deasserts nDATASTB or nADDRSTRB. This marks the beginning of the termination phase.
 - b) The chip drives the sync that indicates that no more wait states are required and drives valid data onto the LAD[3:0] signals, followed by the TAR to complete the read cycle.
8. Peripheral tri-states the PData bus and asserts nWAIT, indicating to the host that the PData bus is tri-stated.
9. Chip may modify nWRITE, PDIR and nPDATA in preparation for the next cycle.

11.3 EPP 1.7 Operation

When the EPP 1.7 mode is selected in the configuration register, the standard and bi-directional modes are also available. If no EPP Read, Write or Address cycle is currently executing, then the PDx bus is in the standard or bi-directional mode, and all output signals (STROBE, AUTOFD, INIT) are as set by the SPP Control Port and direction is controlled by PCD of the Control port.

In EPP mode, the system timing is closely coupled to the EPP timing. For this reason, a watchdog timer is required to prevent system lockup. The timer indicates if more than 10usec have elapsed from the start of the EPP cycle to the end of the cycle. If a time-out occurs, the current EPP cycle is aborted and the time-out condition is indicated in Status bit 0.

11.3.1 Software Constraints

Before an EPP cycle is executed, the software must ensure that the control register bits D0, D1 and D3 are set to zero. Also, bit D5 (PCD) is a logic "0" for an EPP write or a logic "1" for an EPP read.

11.3.2 EPP 1.7 Write

The timing for a write operation (address or data) is shown in timing diagram EPP 1.7 Write Data or Address cycle. The chip inserts wait states into the I/O write cycle when nWAIT is active low during the EPP cycle. This can be used to extend the cycle time. The write cycle can complete when nWAIT is inactive high.

Write Sequence of Operation

1. The host sets PDIR bit in the control register to a logic "0". This asserts nWRITE.
2. The host initiates an I/O write cycle to the selected EPP register.
3. The chip places address or data on PData bus.
4. Chip asserts nDATASTB or nADDRSTRB indicating that PData bus contains valid information, and the WRITE signal is valid.
5. If nWAIT is asserted, the chip inserts wait states into I/O write cycle until the peripheral deasserts nWAIT or a time-out occurs.
6. The chip drives the final sync, deasserts nDATASTB or nADDRSTRB and latches the data from the internal data bus for the PData bus.
7. Chip may modify nWRITE, PDIR and nPDATA in preparation of the next cycle.

11.3.3 EPP 1.7 Read

The timing for a read operation (data) is shown in timing diagram EPP 1.7 Read Data cycle. The chip inserts wait states into the I/O read cycle when nWAIT is active low during the EPP cycle. This can be used to extend the cycle time. The read cycle can complete when nWAIT is inactive high.

Read Sequence of Operation

1. The host sets PDIR bit in the control register to a logic "1". This deasserts nWRITE and tri-states the PData bus.
2. The host initiates an I/O read cycle to the selected EPP register.
3. Chip asserts nDATASTB or nADDRSTRB indicating that PData bus is tri-stated, PDIR is set and the nWRITE signal is valid.
4. If nWAIT is asserted, the chip inserts wait states into the I/O read cycle until the peripheral deasserts nWAIT or a time-out occurs.
5. The Peripheral drives PData bus valid.
6. The Peripheral deasserts nWAIT, indicating that PData is valid and the chip may begin the termination phase of the cycle.
7. The chip drives the final sync and deasserts nDATASTB or nADDRSTRB.
8. Peripheral tri-states the PData bus.
9. Chip may modify nWRITE, PDIR and nPDATA in preparation of the next cycle.

Table 11.2 - EPP Pin Descriptions

EPP SIGNAL	EPP NAME	TYPE	EPP DESCRIPTION
nWRITE	nWrite	O	This signal is active low. It denotes a write operation.
PD<0:7>	Address/Data	I/O	Bi-directional EPP byte wide address and data bus.
INTR	Interrupt	I	This signal is active high and positive edge triggered. (Pass through with no inversion, Same as SPP).
WAIT	nWait	I	This signal is active low. It is driven inactive as a positive acknowledgement from the device that the transfer of data is completed. It is driven active as an indication that the device is ready for the next transfer.
DATASTB	nData Strobe	O	This signal is active low. It is used to denote data read or write operation.
RESET	nReset	O	This signal is active low. When driven active, the EPP device is reset to its initial operational mode.
ADDRSTB	nAddress Strobe	O	This signal is active low. It is used to denote address read or write operation.
PE	Paper End	I	Same as SPP mode.
SLCT	Printer Selected Status	I	Same as SPP mode.
nERR	Error	I	Same as SPP mode.

Notes:

- SPP and EPP can use 1 common register.
- nWrite is the only EPP output that can be over-ridden by SPP control port during an EPP cycle. For correct EPP read cycles, PCD is required to be a low.

11.4 Extended Capabilities Parallel Port

ECP provides a number of advantages, some of which are listed below. The individual features are explained in greater detail in the remainder of this section.

High performance half-duplex forward and reverse channel Interlocked handshake, for fast reliable transfer
 Optional single byte RLE compression for improved throughput (64:1)
 Channel addressing for low-cost peripherals
 Maintains link and data layer separation
 Permits the use of active output drivers
 Permits the use of adaptive signal timing
 Peer-to-peer capability.

11.5 Vocabulary

The following terms are used in this document:

assert: When a signal asserts it transitions to a "true" state, when a signal deasserts it transitions to a "false" state.

forward: Host to Peripheral communication.

reverse: Peripheral to Host communication

Pword: A port word; equal in size to the width of the LPC interface. For this implementation, PWord is always 8 bits.

1 A high level.

0 A low level.

These terms may be considered synonymous:

PeriphClk, nAck
 HostAck, nAutoFd
 PeriphAck, Busy
 nPeriphRequest, nFault
 nReverseRequest, nInit
 nAckReverse, PError
 Xflag, Select
 ECPMode, nSelectIn
 HostClk, nStrobe

Reference Document: [IEEE 1284 Extended Capabilities Port Protocol and ISA Interface Standard, Rev 1.14, July 14, 1993](#). This document is available from Microsoft.

Table 11.3 - Bit map of the Extended Parallel Port Registers

	D7	D6	D5	D4	D3	D2	D1	D0	NOTE	
data	PD7	PD6	PD5	PD4	PD3	PD2	PD1	PD0		
eCPAFifo	Addr/RLE	Address or RLE field							Note 11.4	
dsr	nBusy	nAck	PError	Select	nFault	0	0	0	Note 11.3	
dcr	0	0	Direction	ackIntEn	SelectIn	nInit	autofd	strobe	Note 11.3	
cFifo	Parallel Port Data FIFO								Note 11.4	
eCPDFifo	ECP Data FIFO								Note 11.4	
tFifo	Test FIFO								Note 11.4	
cnfgA	0	0	0	1	0	0	0	0		
cnfgB	compress	intrValue	Parallel Port IRQ			Parallel Port DMA				
ecr	MODE			nErrIntrEn	dmaEn	serviceIntr	full	empty		

Note 11.3 These registers are available in all modes.

Note 11.4 All FIFOs use one common 16 byte FIFO.

Note 11.5 The ECP Parallel Port Config Reg B reflects the IRQ and DMA channel selected by the Configuration Registers.

11.6 ECP Implementation Standard

This specification describes the standard interface to the Extended Capabilities Port (ECP). All LPC devices supporting ECP must meet the requirements contained in this section or the port will not be supported by Microsoft. For a description of the ECP Protocol, please refer to the [IEEE 1284 Extended Capabilities Port Protocol and ISA Interface Standard, Rev. 1.14, July 14, 1993](#). This document is available from Microsoft.

11.6.1 Description

The port is software and hardware compatible with existing parallel ports so that it may be used as a standard LPT port if ECP is not required. The port is designed to be simple and requires a small number of gates to implement. It does not do any "protocol" negotiation, rather it provides an automatic high burst-bandwidth channel that supports DMA for ECP in both the forward and reverse directions.

Small FIFOs are employed in both forward and reverse directions to smooth data flow and improve the maximum bandwidth requirement. The size of the FIFO is 16 bytes deep. The port supports an automatic handshake for the standard parallel port to improve compatibility mode transfer speed.

The port also supports run length encoded (RLE) decompression (required) in hardware. Compression is accomplished by counting identical bytes and transmitting an RLE byte that indicates how many times the next byte is to be repeated. Decompression simply intercepts the RLE byte and repeats the following byte the specified number of times. Hardware support for compression is optional.

Table 11.4 - ECP Pin Descriptions

NAME	TYPE	DESCRIPTION
nStrobe	O	During write operations nStrobe registers data or address into the slave on the asserting edge (handshakes with Busy).
PData 7:0	I/O	Contains address or data or RLE data.
nAck	I	Indicates valid data driven by the peripheral when asserted. This signal handshakes with nAutoFd in reverse.
PeriphAck (Busy)	I	This signal deasserts to indicate that the peripheral can accept data. This signal handshakes with nStrobe in the forward direction. In the reverse direction this signal indicates whether the data lines contain ECP command information or data. The peripheral uses this signal to flow control in the forward direction. It is an "interlocked" handshake with nStrobe. PeriphAck also provides command information in the reverse direction.
PError (nAckReverse)	I	Used to acknowledge a change in the direction the transfer (asserted = forward). The peripheral drives this signal low to acknowledge nReverseRequest. It is an "interlocked" handshake with nReverseRequest. The host relies upon nAckReverse to determine when it is permitted to drive the data bus.
Select	I	Indicates printer on line.
nAutoFd (HostAck)	O	Requests a byte of data from the peripheral when asserted, handshaking with nAck in the reverse direction. In the forward direction this signal indicates whether the data lines contain ECP address or data. The host drives this signal to flow control in the reverse direction. It is an "interlocked" handshake with nAck. HostAck also provides command information in the forward phase.
nFault (nPeriphRequest)	I	Generates an error interrupt when asserted. This signal provides a mechanism for peer-to-peer communication. This signal is valid only in the forward direction. During ECP Mode the peripheral is permitted (but not required) to drive this pin low to request a reverse transfer. The request is merely a "hint" to the host; the host has ultimate control over the transfer direction. This signal would be typically used to generate an interrupt to the host CPU.
nInit	O	Sets the transfer direction (asserted = reverse, deasserted = forward). This pin is driven low to place the channel in the reverse direction. The peripheral is only allowed to drive the bi-directional data bus while in ECP Mode and HostAck is low and nSelectIn is high.
nSelectIn	O	Always deasserted in ECP mode.

11.6.2 Register Definitions

The register definitions are based on the standard IBM addresses for LPT. All of the standard printer ports are supported. The additional registers attach to an upper bit decode of the standard LPT port definition to avoid conflict with standard ISA devices. The port is equivalent to a generic parallel port interface and may be operated in that mode. The port registers vary depending on the mode field in the ecr. The table below lists these dependencies. Operation of the devices in modes other than those specified is undefined.

Table 11.5 - ECP Register Definitions

NAME	ADDRESS (NOTE 11.6)	ECP MODES	FUNCTION
data	+000h R/W	000-001	Data Register
ecpAFifo	+000h R/W	011	ECP FIFO (Address)
dsr	+001h R/W	All	Status Register
dcr	+002h R/W	All	Control Register
cFifo	+400h R/W	010	Parallel Port Data FIFO
ecpDFifo	+400h R/W	011	ECP FIFO (DATA)
tFifo	+400h R/W	110	Test FIFO
cnfgA	+400h R	111	Configuration Register A
cnfgB	+401h R/W	111	Configuration Register B
ecr	+402h R/W	All	Extended Control Register

Note 11.6 These addresses are added to the parallel port base address as selected by configuration register or jumpers.

Note 11.7 All addresses are qualified with AEN. Refer to the AEN pin definition.

Table 11.6 - Mode Descriptions

MODE	DESCRIPTION (NOTE 11.8)
000	SPP mode
001	PS/2 Parallel Port mode
010	Parallel Port Data FIFO mode
011	ECP Parallel Port mode
100	EPP mode (If this option is enabled in the configuration registers)
101	Reserved
110	Test mode
111	Configuration mode

Note 11.8 Refer to ECR Register Description

11.6.2.1 Data And ecpAFifo Port

ADDRESS OFFSET = 00H

Modes 000 and 001 (Data Port)

The Data Port is located at an offset of '00H' from the base address. The data register is cleared at initialization by RESET. During a WRITE operation, the Data Register latches the contents of the data bus. The contents of this register are buffered (non inverting) and output onto the PD0 - PD7 ports. During a READ operation, PD0 - PD7 ports are read and output to the host CPU.

Mode 011 (ECP FIFO - Address/RLE)

A data byte written to this address is placed in the FIFO and tagged as an ECP Address/RLE. The hardware at the ECP port transmits this byte to the peripheral automatically. The operation of this register is only defined for the forward direction (direction is 0). Refer to the ECP Parallel Port Forward Timing Diagram, located in the Timing Diagrams section of this data sheet .

Device Status Register (DSR)

ADDRESS OFFSET = 01H

The Status Port is located at an offset of '01H' from the base address. Bits 0 - 2 are not implemented as register bits, during a read of the Printer Status Register these bits are a low level. The bits of the Status Port are defined as follows:

BIT 3 nFault

The level on the nFault input is read by the CPU as bit 3 of the Device Status Register.

BIT 4 Select

The level on the Select input is read by the CPU as bit 4 of the Device Status Register.

BIT 5 PError

The level on the PError input is read by the CPU as bit 5 of the Device Status Register. Printer Status Register.

BIT 6 nAck

The level on the nAck input is read by the CPU as bit 6 of the Device Status Register.

BIT 7 nBusy

The complement of the level on the BUSY input is read by the CPU as bit 7 of the Device Status Register.

11.6.2.2 Device Control Register (DCR)

ADDRESS OFFSET = 02H

The Control Register is located at an offset of '02H' from the base address. The Control Register is initialized to zero by the RESET input, bits 0 to 5 only being affected; bits 6 and 7 are hard wired low.

**BIT 0 STROBE - STROBE**

This bit is inverted and output onto the nSTROBE output.

BIT 1 AUTOFD - AUTOFEED

This bit is inverted and output onto the nAUTOFD output. A logic 1 causes the printer to generate a line feed after each line is printed. A logic 0 means no autofeed.

BIT 2 nINIT - nINITIATE OUTPUT

This bit is output onto the nINIT output without inversion.

BIT 3 SELECTIN

This bit is inverted and output onto the nSLCTIN output. A logic 1 on this bit selects the printer; a logic 0 means the printer is not selected.

BIT 4 ackIntEn - INTERRUPT REQUEST ENABLE

The interrupt request enable bit when set to a high level may be used to enable interrupt requests from the Parallel Port to the CPU due to a low to high transition on the nACK input. Refer to the description of the interrupt under Operation, Interrupts.

BIT 5 DIRECTION

If mode=000 or mode=010, this bit has no effect and the direction is always out regardless of the state of this bit. In all other modes, Direction is valid and a logic 0 means that the printer port is in output mode (write); a logic 1 means that the printer port is in input mode (read).

BITS 6 and 7 during a read are a low level, and cannot be written.

11.6.2.3 cFifo (Parallel Port Data FIFO)**ADDRESS OFFSET = 400h**

Mode = 010

Bytes written or DMAed from the system to this FIFO are transmitted by a hardware handshake to the peripheral using the standard parallel port protocol. Transfers to the FIFO are byte aligned. This mode is only defined for the forward direction.

11.6.2.4 ecpDFifo (ECP Data FIFO)**ADDRESS OFFSET = 400H**

Mode = 011

Bytes written or DMAed from the system to this FIFO, when the direction bit is 0, are transmitted by a hardware handshake to the peripheral using the ECP parallel port protocol. Transfers to the FIFO are byte aligned.

Data bytes from the peripheral are read under automatic hardware handshake from ECP into this FIFO when the direction bit is 1. Reads or DMAs from the FIFO will return bytes of ECP data to the system.

11.6.2.5 tFifo (Test FIFO Mode)

ADDRESS OFFSET = 400H

Mode = 110

Data bytes may be read, written or DMAed to or from the system to this FIFO in any direction. Data in the tFIFO will not be transmitted to the parallel port lines using a hardware protocol handshake. However, data in the tFIFO may be displayed on the parallel port data lines.

The tFIFO will not stall when overwritten or underrun. If an attempt is made to write data to a full tFIFO, the new data is not accepted into the tFIFO. If an attempt is made to read data from an empty tFIFO, the last data byte is re-read again. The full and empty bits must always keep track of the correct FIFO state. The tFIFO will transfer data at the maximum ISA rate so that software may generate performance metrics.

The FIFO size and interrupt threshold can be determined by writing bytes to the FIFO and checking the full and serviceIntr bits.

The writeIntrThreshold can be determined by starting with a full tFIFO, setting the direction bit to 0 and emptying it a byte at a time until serviceIntr is set. This may generate a spurious interrupt, but will indicate that the threshold has been reached.

The readIntrThreshold can be determined by setting the direction bit to 1 and filling the empty tFIFO a byte at a time until serviceIntr is set. This may generate a spurious interrupt, but will indicate that the threshold has been reached.

Data bytes are always read from the head of tFIFO regardless of the value of the direction bit. For example if 44h, 33h, 22h is written to the FIFO, then reading the tFIFO will return 44h, 33h, 22h in the same order as was written.

11.6.2.6 cnfgA (Configuration Register A)

ADDRESS OFFSET = 400H

Mode = 111

This register is a read only register. When read, 10H is returned. This indicates to the system that this is an 8-bit implementation. (PWord = 1 byte)

11.6.2.7 cnfgB (Configuration Register B)

ADDRESS OFFSET = 401H

Mode = 111

BIT 7 compress

This bit is read only. During a read it is a low level. This means that this chip does not support hardware RLE compression. It does support hardware de-compression!

BIT 6 intrValue

Returns the value of the interrupt to determine possible conflicts.

BITS [5:3] Parallel Port IRQ (read-only)

Refer to Table 11.7B.

BITS [2:0] Parallel Port DMA (read-only)

Refer to Table 11.7C.

11.6.2.8 ecr (Extended Control Register)**ADDRESS OFFSET = 402H**

Mode = all

This register controls the extended ECP parallel port functions.

BITS 7,6,5

These bits are Read/Write and select the Mode.

BIT 4 nErrIntrEn

Read/Write (Valid only in ECP Mode)

- 1: Disables the interrupt generated on the asserting edge of nFault.
- 0: Enables an interrupt pulse on the high to low edge of nFault. Note that an interrupt will be generated if nFault is asserted (interrupting) and this bit is written from a 1 to a 0. This prevents interrupts from being lost in the time between the read of the ecr and the write of the ecr.

BIT 3 dmaEn

Read/Write

- 1: Enables DMA (DMA starts when serviceIntr is 0).
- 0: Disables DMA unconditionally.

BIT 2 serviceIntr

Read/Write

- 1: Disables DMA and all of the service interrupts.
- 0: Enables one of the following 3 cases of interrupts. Once one of the 3 service interrupts has occurred serviceIntr bit shall be set to a 1 by hardware. It must be reset to 0 to re-enable the interrupts. Writing this bit to a 1 will not cause an interrupt.

case dmaEn=1:

During DMA (this bit is set to a 1 when terminal count is reached).

case dmaEn=0 direction=0:

This bit shall be set to 1 whenever there are writeIntrThreshold or more bytes free in the FIFO.

case dmaEn=0 direction=1:

This bit shall be set to 1 whenever there are readIntrThreshold or more valid bytes to be read from the FIFO.

BIT 1 full

Read only

- 1: The FIFO cannot accept another byte or the FIFO is completely full.
- 0: The FIFO has at least 1 free byte.

BIT 0 empty

Read only

- 1: The FIFO is completely empty.
- 0: The FIFO contains at least 1 byte of data.

Table 11.7A - Extended Control Register

R/W	MODE
000:	Standard Parallel Port Mode . In this mode the FIFO is reset and common drain drivers are used on the control lines (nStrobe, nAutoFd, nInIt and nSelectIn). Setting the direction bit will not tri-state the output drivers in this mode.
001:	PS/2 Parallel Port Mode. Same as above except that direction may be used to tri-state the data lines and reading the data register returns the value on the data lines and not the value in the data register. All drivers have active pull-ups (push-pull).
010:	Parallel Port FIFO Mode. This is the same as 000 except that bytes are written or DMAed to the FIFO. FIFO data is automatically transmitted using the standard parallel port protocol. Note that this mode is only useful when direction is 0. All drivers have active pull-ups (push-pull).
011:	ECP Parallel Port Mode. In the forward direction (direction is 0) bytes placed into the ecpDFifo and bytes written to the ecpAFifo are placed in a single FIFO and transmitted automatically to the peripheral using ECP Protocol. In the reverse direction (direction is 1) bytes are moved from the ECP parallel port and packed into bytes in the ecpDFifo. All drivers have active pull-ups (push-pull).
100:	Selects EPP Mode: In this mode, EPP is selected if the EPP supported option is selected in configuration register CR04 (Bits[1,0] and Bit[6]). All drivers have active pull-ups (push-pull).
101:	Reserved
110:	Test Mode. In this mode the FIFO may be written and read, but the data will not be transmitted on the parallel port. All drivers have active pull-ups (push-pull).
111:	Configuration Mode. In this mode the configA, configB registers are accessible at 0x400 and 0x401. All drivers have active pull-ups (push-pull).

Table 11.7B

IRQ SELECTED	CNFGB BITS [5:3]
15	110
14	101
11	100
10	011
9	010
7	001
5	111
All Others	000

Table 11.7C

DMA SELECTED	CNFGB BITS [2:0]
3	011
2	010
1	001
All Others	000

11.6.3 Operation

Mode Switching/Software Control

Software will execute P1284 negotiation and all operation prior to a data transfer phase under programmed I/O control (mode 000 or 001). Hardware provides an automatic control line handshake, moving data between the FIFO and the ECP port only in the data transfer phase (modes 011 or 010).

Setting the mode to 011 or 010 will cause the hardware to initiate data transfer.

If the port is in mode 000 or 001 it may switch to any other mode. If the port is not in mode 000 or 001 it can only be switched into mode 000 or 001. The direction can only be changed in mode 001.

ECP Operation

Prior to ECP operation the Host must negotiate on the parallel port to determine if the peripheral supports the ECP protocol. This is a somewhat complex negotiation carried out under program control in mode 000.

After negotiation, it is necessary to initialize some of the port bits. The following are required:

Set Direction = 0, enabling the drivers.

Set strobe = 0, causing the nStrobe signal to default to the deasserted state.

Set autoFd = 0, causing the nAutoFd signal to default to the deasserted state.

Set mode = 011 (ECP Mode)

ECP address/RLE bytes or data bytes may be sent automatically by writing the ecpAFifo or ecpDFifo respectively.

Note that all FIFO data transfers are byte wide and byte aligned. Address/RLE transfers are byte-wide and only allowed in the forward direction.

The host may switch directions by first switching to mode = 001, negotiating for the forward or reverse channel, setting direction to 1 or 0, then setting mode = 011. When direction is 1 the hardware shall handshake for each ECP read data byte and attempt to fill the FIFO. Bytes may then be read from the ecpDFifo as long as it is not empty.

ECP transfers may also be accomplished (albeit slowly) by handshaking individual bytes under program control in mode = 001, or 000.

Termination from ECP Mode

Termination from ECP Mode is similar to the termination from Nibble/Byte Modes. The host is permitted to terminate from ECP Mode only in specific well-defined states. The termination can only be executed while the bus is in the forward direction. To terminate while the channel is in the reverse direction, it must first be transitioned into the forward direction.

Command/Data

ECP Mode supports two advanced features to improve the effectiveness of the protocol for some applications. The features are implemented by allowing the transfer of normal 8 bit data or 8 bit commands.

When in the forward direction, normal data is transferred when HostAck is high and an 8 bit command is transferred when HostAck is low.

The most significant bit of the command indicates whether it is a run-length count (for compression) or a channel address.

When in the reverse direction, normal data is transferred when PeriphAck is high and an 8 bit command is transferred when PeriphAck is low. The most significant bit of the command is always zero. Reverse channel addresses are seldom used and may not be supported in hardware.

Table 11.8 - Forward and Reverse Channel Commands

**Forward Channel Commands (HostAck Low)
Reverse Channel Commands (PeripAck Low)**

D7	D[6:0]
0	Run-Length Count (0-127) (mode 0011 0X00 only)
1	Channel Address (0-127)

Data Compression

The ECP port supports run length encoded (RLE) decompression in hardware and can transfer compressed data to a peripheral. Run length encoded (RLE) compression in hardware is not supported. To transfer compressed data in ECP mode, the compression count is written to the ecpAFifo and the data byte is written to the ecpDFifo.

Compression is accomplished by counting identical bytes and transmitting an RLE byte that indicates how many times the next byte is to be repeated. Decompression simply intercepts the RLE byte and repeats the following byte the specified number of times. When a run-length count is received from a peripheral, the subsequent data byte is replicated the specified number of times. A run-length count of zero specifies that only one byte of data is represented by the next data byte, whereas a run-length count of 127 indicates that the next byte should be expanded to 128 bytes. To prevent data expansion, however, run-length counts of zero should be avoided.

Pin Definition

The drivers for nStrobe, nAutoFd, nIntr and nSelectIn are open-drain in mode 000 and are push-pull in all other modes.

LPC Connections

The interface can never stall causing the host to hang. The width of data transfers is strictly controlled on an I/O address basis per this specification. All FIFO-DMA transfers are byte wide, byte aligned and end on a byte boundary. (The PWord value can be obtained by reading Configuration Register A, cnfgA, described in the next section). Single byte wide transfers are always possible with standard or PS/2 mode using program control of the control signals.

Interrupts

The interrupts are enabled by serviceIntr in the ecr register.

serviceIntr = 1 Disables the DMA and all of the service interrupts.

serviceIntr = 0 Enables the selected interrupt condition. If the interrupting condition is valid, then the interrupt is generated immediately when this bit is changed from a 1 to a 0. This can occur during Programmed I/O if the number of bytes removed or added from/to the FIFO does not cross the threshold.

An interrupt is generated when:

1. For DMA transfers: When `serviceIntr` is 0, `dmaEn` is 1 and the DMA TC cycle is received.
2. For Programmed I/O:
 - a. When `serviceIntr` is 0, `dmaEn` is 0, `direction` is 0 and there are `writeIntrThreshold` or more free bytes in the FIFO. Also, an interrupt is generated when `serviceIntr` is cleared to 0 whenever there are `writeIntrThreshold` or more free bytes in the FIFO.
 - b. When `serviceIntr` is 0, `dmaEn` is 0, `direction` is 1 and there are `readIntrThreshold` or more bytes in the FIFO. Also, an interrupt is generated when `serviceIntr` is cleared to 0 whenever there are `readIntrThreshold` or more bytes in the FIFO.
3. When `nErrIntrEn` is 0 and `nFault` transitions from high to low or when `nErrIntrEn` is set from 1 to 0 and `nFault` is asserted.
4. When `ackIntrEn` is 1 and the `nAck` signal transitions from a low to a high.

FIFO Operation

The FIFO threshold is set in the chip configuration registers. All data transfers to or from the parallel port can proceed in DMA or Programmed I/O (non-DMA) mode as indicated by the selected mode. The FIFO is used by selecting the Parallel Port FIFO mode or ECP Parallel Port Mode. (FIFO test mode will be addressed separately.) After a reset, the FIFO is disabled. Each data byte is transferred by a Programmed I/O cycle or DMA cycle depending on the selection of DMA or Programmed I/O mode.

The following paragraphs detail the operation of the FIFO flow control. In these descriptions, <threshold> ranges from 1 to 16. The parameter FIFOTHR, which the user programs, is one less and ranges from 0 to 15.

A low threshold value (i.e. 2) results in longer periods of time between service requests, but requires faster servicing of the request for both read and write cases. The host must be very responsive to the service request. This is the desired case for use with a "fast" system. A high value of threshold (i.e. 12) is used with a "sluggish" system by affording a long latency period after a service request, but results in more frequent service requests.

DMA Transfers

DMA transfers are always to or from the `ecpDFifo`, `tFifo` or `CFifo`. DMA utilizes the standard PC DMA services. To use the DMA transfers, the host first sets up the direction and state as in the programmed I/O case. Then it programs the DMA controller in the host with the desired count and memory address. Lastly it sets `dmaEn` to 1 and `serviceIntr` to 0. The ECP requests DMA transfers from the host by encoding the `LDRQ#` pin. The DMA will empty or fill the FIFO using the appropriate direction and mode. When the terminal count in the DMA controller is reached, an interrupt is generated and `serviceIntr` is asserted, disabling DMA. In order to prevent possible blocking of refresh requests a DMA cycle shall not be requested for more than 32 DMA cycles in a row. The FIFO is enabled directly by the host initiating a DMA cycle for the requested channel, and addresses need not be valid. An interrupt is generated when a TC cycle is received. (Note: The only way to properly terminate DMA transfers is with a TC cycle.)

DMA may be disabled in the middle of a transfer by first disabling the host DMA controller. Then setting `serviceIntr` to 1, followed by setting `dmaEn` to 0, and waiting for the FIFO to become empty or full. Restarting the DMA is accomplished by enabling DMA in the host, setting `dmaEn` to 1, followed by setting `serviceIntr` to 0.

DMA Mode - Transfers from the FIFO to the Host

Note: In the reverse mode, the peripheral may not continue to fill the FIFO if it runs out of data to transfer, even if the chip continues to request more data from the peripheral.

The ECP requests a DMA cycle whenever there is data in the FIFO. The DMA controller responds to the request by reading data from the FIFO. The ECP stop requesting DMA cycles when the FIFO becomes



empty or when a TC cycle is received, indicating that no more data is required. If the ECP stops requesting DMA cycles due to the FIFO going empty, then a DMA cycle is requested again as soon as there is one byte in the FIFO. If the ECP stops requesting DMA cycles due to the TC cycle, then a DMA cycle is requested again when there is one byte in the FIFO, and `serviceIntr` has been re-enabled.

Programmed I/O Mode or Non-DMA Mode

The ECP or parallel port FIFOs may also be operated using interrupt driven programmed I/O. Software can determine the `writeIntrThreshold`, `readIntrThreshold`, and FIFO depth by accessing the FIFO in Test Mode.

Programmed I/O transfers are to the `ecpDFifo` at 400H and `ecpAFifo` at 000H or from the `ecpDFifo` located at 400H, or to/from the `tFifo` at 400H. To use the programmed I/O transfers, the host first sets up the direction and state, sets `dmaEn` to 0 and `serviceIntr` to 0.

The ECP requests programmed I/O transfers from the host by activating the interrupt. The programmed I/O will empty or fill the FIFO using the appropriate direction and mode.

Note: A threshold of 16 is equivalent to a threshold of 15. These two cases are treated the same.

Programmed I/O - Transfers from the FIFO to the Host

In the reverse direction an interrupt occurs when `serviceIntr` is 0 and `readIntrThreshold` bytes are available in the FIFO. If at this time the FIFO is full it can be emptied completely in a single burst, otherwise `readIntrThreshold` bytes may be read from the FIFO in a single burst.

`readIntrThreshold` = (16-<threshold>) data bytes in FIFO

An interrupt is generated when `serviceIntr` is 0 and the number of bytes in the FIFO is greater than or equal to (16-<threshold>). (If the threshold = 12, then the interrupt is set whenever there are 4-16 bytes in the FIFO). The host must respond to the request by reading data from the FIFO. This process is repeated until the last byte is transferred out of the FIFO. If at this time the FIFO is full, it can be completely emptied in a single burst, otherwise a minimum of (16-<threshold>) bytes may be read from the FIFO in a single burst.

Programmed I/O - Transfers from the Host to the FIFO

In the forward direction an interrupt occurs when `serviceIntr` is 0 and there are `writeIntrThreshold` or more bytes free in the FIFO. At this time if the FIFO is empty it can be filled with a single burst before the empty bit needs to be re-read. Otherwise it may be filled with `writeIntrThreshold` bytes.

`writeIntrThreshold` = (16-<threshold>) free bytes in FIFO

An interrupt is generated when `serviceIntr` is 0 and the number of bytes in the FIFO is less than or equal to <threshold>. (If the threshold = 12, then the interrupt is set whenever there are 12 or less bytes of data in the FIFO.) The host must respond to the request by writing data to the FIFO. If at this time the FIFO is empty, it can be completely filled in a single burst, otherwise a minimum of (16-<threshold>) bytes may be written to the FIFO in a single burst. This process is repeated until the last byte is transferred into the FIFO.

Chapter 12 Power Management

Power management capabilities are provided for the following logical devices: UART 1, UART 2 and the parallel port. For each logical device, two types of power management are provided: direct powerdown and auto powerdown.

12.1 UART Power Management

Direct power management is controlled by CR02. Refer to the Configuration section for more information.

Auto Power Management is enabled by the UART1 and UART2 enable bits in CR07. When set, these bits allow the following auto power management operations:

1. The transmitter enters auto powerdown when the transmit buffer and shift register are empty.
2. The receiver enters powerdown when the following conditions are all met:
 - A. Receive FIFO is empty
 - B. The receiver is waiting for a start bit.

Note: While in powerdown the Ring Indicator interrupt is still valid and transitions when the RI input changes.

12.1.1 Exit Auto Powerdown

The transmitter exits powerdown on a write to the XMIT buffer. The receiver exits auto powerdown when RXDx changes state.

12.2 Parallel Port

Direct power management is controlled by Bit[2] in CR01. Refer to the Configuration section for more information.

Auto Power Management is enabled by Bit[4] in CR07. When set, this bit allows the ECP or EPP logical parallel port blocks to be placed into powerdown when not being used.

The EPP logic is in powerdown under any of the following conditions:

1. EPP is not enabled in the configuration registers.
2. EPP is not selected through ecr while in ECP mode.

The ECP logic is in powerdown under any of the following conditions:

1. ECP is not enabled in the configuration registers.
2. SPP, PS/2 Parallel port or EPP mode is selected through ecr while in ECP mode.

12.2.1 Exit Auto Powerdown

The parallel port logic can change powerdown modes when the ECP mode is changed through the ecr register or when the parallel port mode is changed through the configuration registers.

Chapter 13 Serial IRQ

The LPC47N217 supports the serial interrupt to transmit interrupt information to the host system. The serial interrupt scheme adheres to the Serial IRQ Specification for PCI Systems, Version 6.0. The PCI_CLK, SER_IRQ and CLKRUN# pins are used for this interface. The Serial IRQ/CLKRUN Enable bit D7 in CR29 activates the serial interrupt interface.

13.1 Timing Diagrams For SER_IRQ Cycle

A) Start Frame timing with source sampled a low pulse on IRQ1

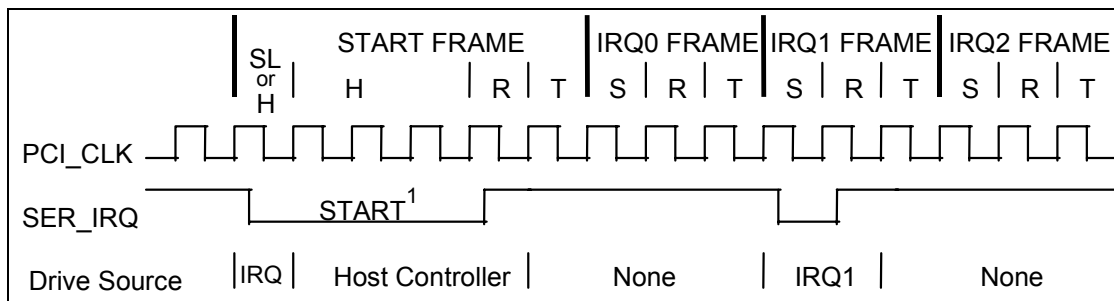

Note: H=Host Control; R=Recovery; T=Turn-Around; SL=Slave Control; S=Sample

Note 1: Start Frame pulse can be 4-8 clocks wide depending on the location of the device in the PCI bridge hierarchy in a synchronous bridge design.

B) Stop Frame Timing with Host using 17 SER_IRQ sampling period

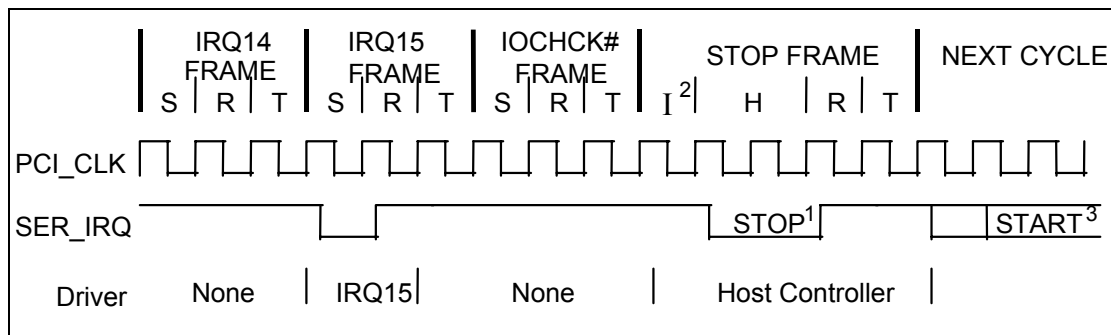

Note: H=Host Control; R=Recovery; T=Turn-Around; S=Sample; I=Idle

Note 1: Stop pulse is 2 clocks wide for Quiet mode, 3 clocks wide for Continuous mode.

Note 2: There may be none, one or more Idle states during the Stop Frame.

Note 3: The next SER_IRQ cycle's Start Frame pulse may or may not start immediately after the turn-around clock of the Stop Frame.

13.1.1 SER_IRQ Cycle Control

There are two modes of operation for the SER_IRQ Start Frame.

1. **Quiet (Active) Mode:** Any device may initiate a Start Frame by driving the SER_IRQ low for one clock, while the SER_IRQ is Idle. After driving low for one clock the SER_IRQ is immediately tri-stated without at any time driving high. A Start Frame may not be initiated while the SER_IRQ is Active. The SER_IRQ is Idle between Stop and Start Frames. The SER_IRQ is Active between Start and Stop Frames. This mode of operation allows the SER_IRQ to be Idle when there are no IRQ/Data transitions which should be most of the time.

Once a Start Frame has been initiated the Host Controller will take over driving the SER_IRQ low in the next clock and will continue driving the SER_IRQ low for a programmable period of three to seven clocks. This makes a total low pulse width of four to eight clocks. Finally, the Host Controller will drive the SER_IRQ back high for one clock, then tri-state.

Any SER_IRQ Device (i.e., The LPC47N217) which detects any transition on an IRQ/Data line for which it is responsible must initiate a Start Frame in order to update the Host Controller unless the SER_IRQ is already in an SER_IRQ Cycle and the IRQ/Data transition can be delivered in that SER_IRQ Cycle.

2. **Continuous (Idle) Mode:** Only the Host controller can initiate a Start Frame to update IRQ/Data line information. All other SER_IRQ agents become passive and may not initiate a Start Frame. SER_IRQ will be driven low for four to eight clocks by Host Controller. This mode has two functions. It can be used to stop or idle the SER_IRQ or the Host Controller can operate SER_IRQ in a continuous mode by initiating a Start Frame at the end of every Stop Frame.

An SER_IRQ mode transition can only occur during the Stop Frame. Upon reset, SER_IRQ bus is defaulted to Continuous mode, therefore only the Host controller can initiate the first Start Frame. Slaves must continuously sample the Stop Frames pulse width to determine the next SER_IRQ Cycle's mode.

13.1.2 SER_IRQ Data Frame

Once a Start Frame has been initiated, the LPC47N217 will watch for the rising edge of the Start Pulse and start counting IRQ/Data Frames from there. Each IRQ/Data Frame is three clocks: Sample phase, Recovery phase, and Turn-around phase. During the Sample phase the LPC47N217 drives the SER_IRQ low, if and only if, its last detected IRQ/Data value was low. If its detected IRQ/Data value is high, SER_IRQ is left tri-stated. During the Recovery phase the LPC47N217 drives the SER_IRQ high, if and only if, it had driven the SER_IRQ low during the previous Sample Phase. During the Turn-around Phase the LPC47N217 tri-states the SER_IRQ. The LPC47N217 will drive the SER_IRQ line low at the appropriate sample point if its associated IRQ/Data line is low, regardless of which device initiated the Start Frame.

The Sample Phase for each IRQ/Data follows the low to high transition of the Start Frame pulse by a number of clocks equal to the IRQ/Data Frame times three, minus one. (e.g. The IRQ5 Sample clock is the sixth IRQ/Data Frame, $(6 \times 3) - 1 = 17$ th clock after the rising edge of the Start Pulse).

Table 13.1 - SER_IRQ Sampling Periods

SER_IRQ PERIOD	SIGNAL SAMPLED	# OF CLOCKS PAST START
1	Not Used	2
2	IRQ1	5
3	IO_SMI#/IRQ2	8
4	IRQ3	11
5	IRQ4	14
6	IRQ5	17
7	IRQ6	20
8	IRQ7	23
9	IRQ8	26
10	IRQ9	29
11	IRQ10	32
12	IRQ11	35
13	IRQ12	38
14	IRQ13	41
15	IRQ14	44
16	IRQ15	47

The SER_IRQ data frame supports IRQ2 from a logical device on Period 3, which can be used for the System Management Interrupt (nSMI). When using Period 3 for IRQ2 the user should mask off the SMI via the SMI Enable Register. Likewise, when using Period 3 for nSMI the user should not configure any logical devices as using IRQ2.

SER_IRQ Period 14 is used to transfer IRQ13. Logical devices Parallel Port, Serial Port 1, Serial Port 2 have IRQ13 as a choice for their primary interrupt.

The SMI is enabled onto the SMI frame of the Serial IRQ via bit 6 of SMI Enable Register 2 and onto the IO_SMI# pin via bit 7 of the SMI Enable Register 2.

13.1.3 Stop Cycle Control

Once all IRQ/Data Frames have completed the Host Controller will terminate SER_IRQ activity by initiating a Stop Frame. Only the Host Controller can initiate the Stop Frame. A Stop Frame is indicated when the SER_IRQ is low for two or three clocks. If the Stop Frame's low time is two clocks then the next SER_IRQ Cycle's sampled mode is the Quiet mode; and any SER_IRQ device may initiate a Start Frame in the second clock or more after the rising edge of the Stop Frame's pulse. If the Stop Frame's low time is three clocks then the next SER_IRQ Cycle's sampled mode is the Continuous mode; and only the Host Controller may initiate a Start Frame in the second clock or more after the rising edge of the Stop Frame's pulse.

13.1.4 Latency

Latency for IRQ/Data updates over the SER_IRQ bus in bridge-less systems with the minimum Host supported IRQ/Data Frames of seventeen, will range up to 96 clocks (3.84 μ S with a 25MHz PCI Bus or 2.88 μ S with a 33MHz PCI Bus). If one or more PCI to PCI Bridge is added to a system, the latency for IRQ/Data updates from the secondary or tertiary buses will be a few clocks longer for synchronous buses, and approximately double for asynchronous buses.

13.1.5 EOI/ISR Read Latency

Any serialized IRQ scheme has a potential implementation issue related to IRQ latency. IRQ latency could cause an EOI or ISR Read to precede an IRQ transition that it should have followed. This could cause a system fault. The host interrupt controller is responsible for ensuring that these latency issues are mitigated. The recommended solution is to delay EOIs and ISR Reads to the interrupt controller by the same amount as the SER_IRQ Cycle latency in order to ensure that these events do not occur out of order.

13.1.6 AC/DC Specification Issue

All SER_IRQ agents must drive / sample SER_IRQ synchronously related to the rising edge of PCI bus clock. The SER_IRQ pin uses the electrical specification of PCI bus. Electrical parameters will follow PCI spec. section 4, sustained tri-state.

13.1.7 Reset and Initialization

The SER_IRQ bus uses PCI_RESET# as its reset signal. The SER_IRQ pin is tri-stated by all agents while PCI_RESET# is active. With reset, SER_IRQ Slaves are put into the (continuous) IDLE mode. The Host Controller is responsible for starting the initial SER_IRQ Cycle to collect system's IRQ/Data default values. The system then follows with the Continuous/Quiet mode protocol (Stop Frame pulse width) for subsequent SER_IRQ Cycles. It is Host Controller's responsibility to provide the default values to 8259's and other system logic before the first SER_IRQ Cycle is performed. For SER_IRQ system suspend, insertion, or removal application, the Host controller should be programmed into Continuous (IDLE) mode first. This is to guarantee SER_IRQ bus is in IDLE state before the system configuration changes.

13.2 Routable IRQ Inputs

The routable IRQ input (IRQINx) functions are on pins 51 (IRQIN1) and 52 (IRQIN2), muxed onto GP13 and GP14 respectively as inputs. The IRQINx pin's IRQ time slot in the Serial IRQ stream is selected via a 4-bit control register for each IRQIN function (CR29 for IRQIN1, CR2A for IRQIN2). A value of 0000 disables the IRQ function.

The part is able to generate a PME and an SMI from both of the IRQ inputs through the GPIO bits in the PME and SMI status and enable registers. The edge is programmable through the polarity bit of the GPIO control register.

User Note: In order to use an IRQ for one of the IRQINx inputs that are muxed on the GPIO pins, the corresponding IRQ must not be used for any of the devices in the LPC47N217. Otherwise contention may occur.

Application Note:

If GPIO function is selected on GP13/IRQIN1 and GP14/IRQIN2 pins and if IRQ is selected using the routing registers (CR29 for IRQIN1 and CR2A for IRQIN2), IRQs will be generated on the Serial IRQ stream. The state of the GPIO pins will be reflected on the serial IRQ stream. The IRQ selection bits should be '0000' in the IRQ routing registers when GPIO functions are used. These IRQ selection bits default to '0000' on VCC POR.

Chapter 14 PCI CLKRUN# Support

14.1 Overview

The LPC47N217 supports the PCI CLKRUN# signal. CLKRUN# is used to indicate the PCI clock status as well as to request that a stopped clock be started. The LPC47N217 CLKRUN# signal is on pin number 28. See Figure 14.1 for an example of a typical system implementation using CLKRUN#.

If the LPC47N217 SIRQ_CLKRUN_EN signal is disabled, it will disable the CLKRUN# support related to LDRQ# in addition to disabling the SER_IRQ and the CLKRUN# associated with SER_IRQ.

CLKRUN# is an open drain output and an input. Refer to the *PCI Mobile Design Guide Rev 1.0* for a description of the CLKRUN# function.

14.2 CLKRUN# for Serial IRQ

The LPC47N217 supports the PCI CLKRUN# signal for the Serial IRQs. If an SIO interrupt occurs while the PCI clock is stopped, CLKRUN# is asserted before the serial interrupt signal is driven active.

See “Using CLKRUN#” section below for more details.

14.3 CLKRUN# for LDRQ#

CLKRUN# support is also provided in the LPC47N217 for the LDRQ# signal. If a device requests DMA service while the PCI clock is stopped, CLKRUN# is asserted to restart the PCI clock. This is required to drive the LDRQ# signal active.

See “Using CLKRUN#” section for more details.

14.4 Using CLKRUN#

If CLKRUN# is sampled “high”, the PCI clock is stopped or stopping. If CLKRUN# is sampled “low”, the PCI clock is starting or started (running). If a device in the LPC47N217 asserts or de-asserts an interrupt or asserts a DMA request, and CLKRUN# is sampled “high”, the LPC47N217 requests the restoration of the clock by asserting the CLKRUN# signal asynchronously (Table 14.1). The LPC47N217 holds CLKRUN# low until it detects two rising edges of the clock. After the second clock edge, the LPC47N217 disables the open drain driver (Figure 14.2).

The LPC47N217 will not assert CLKRUN# under any conditions if SIRQ_CLKRUN_EN is inactive (“0”). The SIRQ_CLKRUN_EN bit is D7 in CR29.

The LPC47N217 will not assert CLKRUN# if it is already driven low by the central resource; i.e., the PCI CLOCK GENERATOR in Figure 14.1. The LPC47N217 will not assert CLKRUN# unless the line has been deasserted for two successive clocks; i.e., before the clock was stopped (Figure 14.2).

Table 14.1 - LPC47N217 CLKRUN# Function

SIRQ_CLKRUN_EN	INTERNAL INTERRUPTS/ DMA REQUESTS	CLKRUN#	ACTION
0	X	X	None
1	NO CHANGE	X	None
	CHANGE/ASSERTION (Note 14.1)	0	None
		1	Assert CLKRUN# (Note 14.2)

Note 14.1 “Change/Assertion” means either-edge change on any internal IRQs routed to the SIRQ block or assertion of an internal DMA request by a device in LPC47N217. The “assertion” detection logic runs asynchronously to the PCI Clock and regardless of the Serial IRQ mode; i.e., “continuous” or “quiet”.

Note 14.2 The CLKRUN# signal is ‘1’ for at least two consecutive clocks before LPC47N217 asserts (‘0’) it.

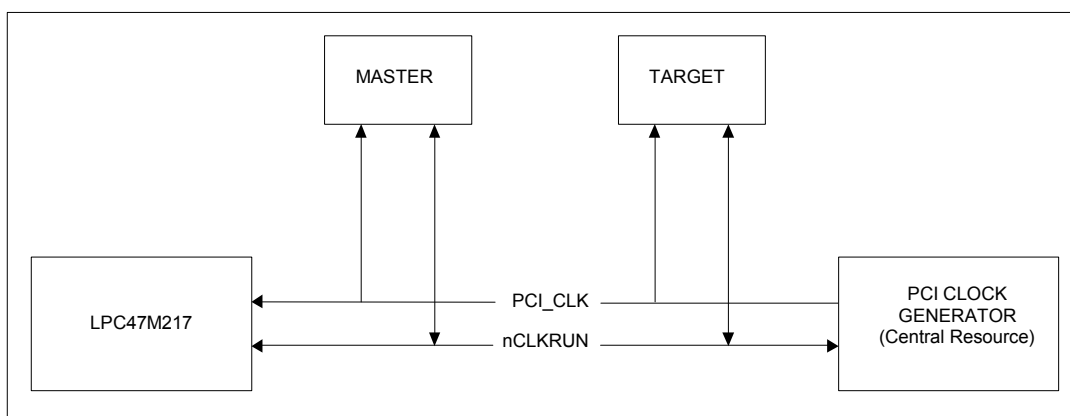
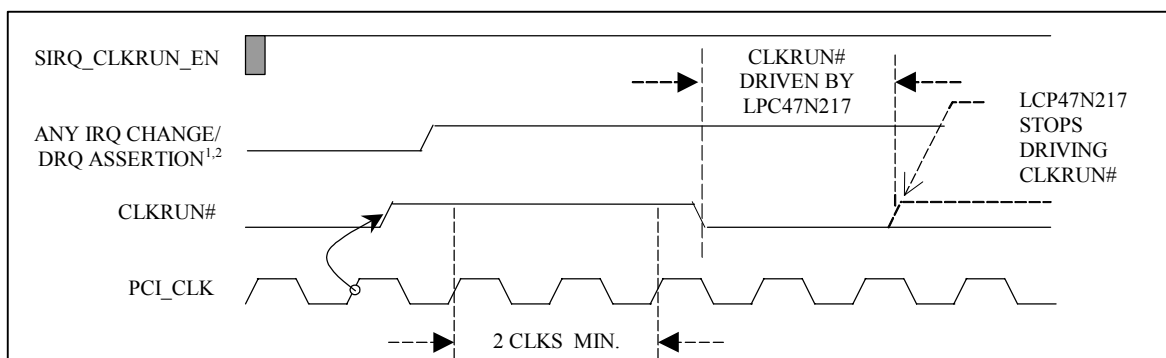
Figure 14.1 - CLKRUN# System Implementation Example

Figure 14.2 - Clock Start Illustration

Note 1: The signal “ANY IRQ CHANGE/DRQ ASSERTION” is the same as “CHANGE/ASSERTION” in Table 14.1.

Note 2: The LPC47N217 continually monitors the state of CLKRUN# to maintain the PCI Clock until an active “ANY IRQ CHANGE/DRQ ASSERTION” condition has been transferred to the host in a SER_IRQ/DMA cycle. For example, if “ANY IRQ CHANGE/DRQ ASSERTION” is asserted before CLKRUN# is de-asserted (not shown in Figure 14.2), the LPC47N217 must assert CLKRUN# as needed until the SER_IRQ/DMA cycle has completed.

Chapter 15 General Purpose I/O

The LPC47N217 provides a set of flexible Input/Output control functions to the system designer through the 14 independently programmable General Purpose I/O pins (GPIO). The GPIO pins can perform basic I/O and many of them can be individually enabled to generate an SMI and a PME.

15.1 GPIO Pins

The following pins include GPIO functionality as defined in the table below.

Table 15.1 - GPIO Pin Functionality

PIN	NAME	POWER WELL	DEFAULT ON VTR POR	DEFAULT ON VCC POR	PME/SMI FUNCTION
23	GP40	VCC	Input	Programmable	-
24	GP41	VCC	Input	Programmable	-
25	GP42	VCC	Input	Programmable	-
27	GP43	VCC	Input	Programmable	-
28	GP44	VCC	Input	Programmable	-
29	GP45	VCC	Input	Programmable	-
30	GP46	VCC	Input	Programmable	-
31	GP47	VCC	Input	Programmable	-
32	GP10	VCC (Note 15.1)	Input	Programmable	PME/SMI
33	GP11/SYSOPT	VCC (Note 15.1)	Input	Programmable	PME/SMI
34	GP12/IO_SMI#	VCC (Note 15.1)	Input	Programmable	IO_SMI#/ PME/SMI
35	GP13/IRQIN1	VCC (Note 15.1)	Input	Programmable	PME/SMI
36	GP14/IRQIN2	VCC (Note 15.1)	Input	Programmable	PME/SMI
40	GP23	VCC (Note 15.1)	Input	Programmable	PME/SMI

Note 15.1 These pins have input buffers into the wakeup logic that are powered by VTR.

15.2 Description

Each GPIO port has a 1-bit data register. GPIOs are controlled by GPIO control registers located in Chapter 19 - Configuration. The data register for each GPIO port is represented as a bit in one of the 8-bit GPIO DATA Registers, GP1, GP2, and GP4. The bits in these registers reflect the value of the associated GPIO pin as follows. Pin is an input: The bit is the value of the GPIO pin. Pin is an output: The value written to the bit goes to the GPIO pin. Latched on read and write. The GPIO data registers are located in the Runtime Register block; see Chapter 18 - Runtime Registers. The GPIO ports with their alternate functions and configuration state register addresses are listed in Table 15.2.

Table 15.2 - General Purpose I/O Port Assignments

PIN NO. /QFP	DEFAULT FUNCTION	ALTERNATE FUNCTION	DATA REGISTER (NOTE 15.2)	DATA REGISTER BIT NO.	REGISTER OFFSET (HEX)
32	GPIO		GP1	0	0C
33	GPIO			1	
34	GPIO	IO_SMI#		2	
35	GPIO	IRQIN1		3	
36	GPIO	IRQIN2		4	
N/A	Reserved			5	
N/A	Reserved			6	
N/A	Reserved			7	
N/A	Reserved		GP2	0	0D
N/A	Reserved			1	
N/A	Reserved			2	
40	GPIO			3	
N/A	Reserved			4	
N/A	Reserved			5	
N/A	Reserved			6	
N/A	Reserved			7	
23	GPIO		GP4	0	0F
24	GPIO			1	
25	GPIO			2	
27	GPIO			3	
28	GPIO			4	
29	GPIO			5	
30	GPIO			6	
31	GPIO			7	

Note 15.2 The GPIO Data Registers are located at the offset shown from the RUNTIME REGISTERS BLOCK address.

15.3 GPIO Control

Each GPIO port has an 8-bit control register that controls the behavior of the pin. These registers are defined in the Configuration section of this specification.

Each GPIO port may be configured as either an input or an output. If the pin is configured as an output, it can be programmed as open-drain or push-pull. Inputs and outputs can be configured as non-inverting or inverting. GPIO Direction Registers determine the port direction, GPIO Polarity Registers determine the signal polarity, and GPIO Output Type Register determines the output driver type select. The GPIO Output Type Register applies to certain GPIOs (GP12-GP14). The GPIO Direction, Polarity and Output Type Registers control the GPIO pin when the pin is configured for the GPIO function and when the pin is configured for the alternate function for all pins.

The basic GPIO configuration options are summarized in Table 15.3.

Table 15.4 - GPIO Read/Write Behavior

HOST OPERATION	GPIO INPUT PORT	GPIO OUTPUT PORT
READ	LATCHED VALUE OF GPIO PIN	LAST WRITE TO GPIO DATA REGISTER
WRITE	NO EFFECT	BIT PLACED IN GPIO DATA REGISTER

The LPC47N217 provides 14 GPIOs that can directly generate a PME. See the table in the next section. The GPIO Polarity Registers in the Configuration section select the edge on these GPIO pins that will set the associated status bit in the PME_STS1 – PME_STS2 registers. The default is the low-to-high edge. If the corresponding enable bit in the PME_EN1 – PME_EN2 registers and the PME_EN bit in the PME_EN register is set, a PME will be generated. These registers are located in the Runtime Registers Block, which is located at the address contained in the configuration registers CR30. The PME status bits for the GPIOs are cleared on a write of '1'. In addition, the LPC47N217 provides 6 GPIOs that can directly generate an SMI. See the table in the next section.

15.5 GPIO PME and SMI Functionality

The following GPIOs are dedicated wakeup GPIOs with a status and enable bit in the PME status and enable registers:

GP10-GP14
GP23

This following is the list of PME status and enable registers for their corresponding GPIOs:

PME_STS1 and PME_EN1 for GP10-GP14
PME_STS2 and PME_EN2 for GP23

The following GPIOs can directly generate an SMI and have a status and enable bit in the SMI status and enable registers.

GP10-GP14
GP23

The following SMI status and enable registers for these GPIOs:

SMI_STS1 and SMI_EN1 for GP10-14
SMI_STS2 and SMI_EN2 for GP23

The following table summarizes the PME and SMI functionality for each GPIO.

Table 15.5 - PME and SMI Functionality

GPIO	PME	SMI	OUTPUT BUFFER POWER	NOTES
GP10-GP11	Yes	Yes	VCC	
GP12	Yes	Yes/IO_SMI#	VCC	Note 15.3
GP13-GP14	Yes	Yes	VCC	
GP23	Yes	Yes	VCC	
GP40-GP47	No	No	VCC	Note 15.4

Note 15.3 Since GP12 can be used to generate an SMI and as the IO_SMI# output, do not enable GP12 to generate an SMI (by setting bit 2 of the SMI Enable Register 1) if the IO_SMI# function is selected on the GP12 pin. Use GP12 to generate an SMI event only if the SMI output is enabled on the Serial IRQ stream.

Note 15.4 GP40-GP47 should not be connected to any VTR powered external circuitry. These pins are not used for wakeup.

Chapter 16 System Management Interrupt (SMI)

The LPC47N217 implements a “group” IO_SMI# output pin. The System Management Interrupt is a non-maskable interrupt with the highest priority level used for OS transparent power management. The nSMI group interrupt output consists of the enabled interrupts from Super I/O Device Interrupts (Parallel Port, Serial Port 1 and Serial Port 2) and many of the GPIOs pins. The GP12/IO_SMI# pin when selected for the IO_SMI# function can be programmed to be active high or active low via bit 2 in the GPIO Polarity Register 1 (CR32). The IO_SMI# pin function defaults to active low. The output buffer type of the pin can be programmed to be open-drain or push-pull via GPIO Output Type Register (CR39).

The interrupts are enabled onto the group nSMI output via the SMI Enable Registers 1 and 2. The nSMI output is then enabled onto the IO_SMI# output pin via bit[7] in the SMI Enable Register 2. The SMI output can also be enabled onto the serial IRQ stream (IRQ2) via Bit[6] in the SMI Enable Register 2.

16.1 SMI Registers

The SMI event bits for the GPIOs events are located in the SMI status and Enable registers 1 and 2. The polarity of the edge used to set the status bit and generate an SMI is controlled by the GPIO Polarity Registers located in the Configuration section. For non-inverted polarity (default) the status bit is set on the low-to-high edge. Status bits for the GPIOs are cleared on a write of ‘1’.

The SMI logic for the GPIO events is implemented such that the output of the status bit for each event is combined with the corresponding enable bit in order to generate an SMI.

The SMI event bits for the super I/O devices are located in the SMI status and enable register 1 and 2. All of these status bits are cleared at the source; these status bits are not cleared by a write of ‘1’. The SMI logic for these events is implemented such that each event is directly combined with the corresponding enable bit in order to generate an SMI.

See Chapter 18 - Runtime Registers on page 80 for the definition of the SMI status and enable registers.

Chapter 17 PME Support

The LPC47N217 offers support for Power Management Events (PMEs), also referred to as System Control Interrupt (SCI) events in an ACPI system. A power management event is indicated to the chipset via the assertion of the IO_PME# signal. In the LPC47N217, the IO_PME# is asserted by active transitions on the ring indicator input nRI1 and programmable edges on GPIO pins. The IO_PME# pin can be programmed to be active high or active low via bit 5 in the GPIO Polarity Register 2 (CR34). The IO_PME# pin function defaults to active low, open-drain output. The output buffer type of the pin can be programmed to be open-drain or push-pull via bit 7 in the GPIO Output Type Register (CR39). This pin is powered by VTR. See Chapter 19 - Configuration on page 86 for description on these registers.

PME functionality is controlled by the PME status and enable registers in the runtime registers block, which is located at the address programmed in register 0x30 in the Configuration section. The PME Enable bit, PME_EN, globally controls PME Wake-up events. When PME_EN is inactive, the IO_PME# signal cannot be asserted. When PME_EN is asserted, any wake source whose individual PME Wake Enable register bit is asserted can cause IO_PME# to become asserted.

The PME Status register indicates that an enabled wake source has occurred and if the PME_EN bit is set, asserted the IO_PME# signal. The PME Status bit is asserted by active transitions of PME wake sources. PME_STS will become asserted independent of the state of the global PME enable, PME_EN.

The following pertains to the PME status bits for each event:

- The output of the status bit for each event is combined with the corresponding enable bit to set the PME status bit.
- The status bit for any pending events must be cleared in order to clear the PME_STS bit. Status bits are cleared on a write of '1'.

For the GPIO events, the polarity of the edge used to set the status bit and generate a PME is controlled by the GPIO Polarity Registers in the Configuration section. For non-inverted polarity (default) the status bit is set on the low-to-high edge. Status bits are cleared on a write of '1'.

In the LPC47N217 the IO_PME# pin can be programmed to be an open drain, active low, driver. The LPC47N217 IO_PME# pin is fully isolated from other external devices that might pull the IO_PME# signal low; i.e., the IO_PME# signal is capable of being driven high externally by another active device or pull-up even when the LPC47N217 VCC is grounded, providing VTR power is active.

17.1 PME Registers

The PME registers are run-time registers as follows. These registers are located in system I/O space at an offset from Runtime Registers Block, the address programmed at register 0x30 in the Configuration section.

The following registers are for GPIO PME events:

- PME Wake Status 1 (PME_STS1), PME Wake Enable 1 (PME_EN1)
- PME Wake Status 2 (PME_STS2), PME Wake Enable 2 (PME_EN2)

See PME register description in Chapter 18 - Runtime Registers on page 80.

Chapter 18 Runtime Registers

18.1 Runtime Registers Block Summary

The runtime registers are located at the address programmed in the Runtime Register Block Base Address configuration register located in CR30. The part performs 16-bit address qualification on the Runtime Register Base Address (bits[11:0] are decoded and bits[15:12] must be zero). The runtime register block may be located within the range 0x0100-0x0FFF on 16-byte boundaries. Decodes are disabled if the Runtime Register Base Address is located below 0x100. These registers are powered by VTR.

Table 18.1 - Runtime Register Block Summary

REGISTER OFFSET (hex)	TYPE	HARD RESET	VCC POR	VTR POR	REGISTER
00	R/W	-	-	0x00	PME_STS
01	R/W	-	-	0x00	PME_EN
02	R/W	-	-	0x00	PME_STS1
03	R/W	-	-	0x00	PME_STS2
04	R/W	-	-	0x00	Reserved
05	R/W	-	-	0x00	PME_EN1
06	R/W	-	-	0x00	PME_EN2
07	R/W	-	-	0x00	Reserved
08	R/W	-	-	0x00	SMI_STS1
09	R/W	(Note 18.1)	(Note 18.1)	0x01 (Note 18.1)	SMI_STS2
0A	R/W	-	-	0x00	SMI_EN1
0B	R/W	-	-	0x00	SMI_EN2
0C	R/W	-	-	0x00	GP1
0D	R/W	-	-	0x00	GP2
0E	R/W	-	-	0x00	SMSC Reserved
0F	R/W	-	-	0x00	GP4

Notes:

- Hard Reset: PCI_RESET# pin asserted.
- “Reserved” bits return 0 on read.
- “SMSC Reserved” bits/registers are reserved for SMSC use only. Writing to these registers may cause unwanted results. SMSC Reserved bits should be written to their default value when updating the register they reside in.

Note 18.1 The parallel port interrupt defaults to 1 when the parallel port power bit is cleared. When the parallel port is activated, PINT follows the nACK input.

18.2 Runtime Registers Block Description

Table 18.2 - Runtime Registers Block Description

NAME/DEFAULT	REGISTER OFFSET	DESCRIPTION
PME_STS Default = 0x00 on VTR POR	00 (R/W)	Bit[0] PME_Status = 0 (default) = 1 Set when LPC47N217 would normally assert the IO_PME# signal, independent of the state of the PME_En bit. Bit[7:1] Reserved PME_Status is not affected by VCC POR, SOFT RESET or HARD RESET. Writing a "1" to PME_Status will clear it and cause the LPC47N217 to stop asserting IO_PME#, in enabled. Writing a "0" to PME_Status has no effect.
PME_EN Default = 0x00 on VTR POR	01 (R/W)	Bit[0] PME_En = 0 IO_PME# signal assertion is disabled (default) = 1 Enables LPC47N217 to assert IO_PME# signal Bit[7:1] Reserved PME_En is not affected by VCC POR, SOFT RESET or HARD RESET
PME_STS1 Default = 0x00 on VTR POR	02 (R/W)	PME Wake Status Register 1 This register indicates the state of the individual PME wake sources, independent of the individual source enables or the PME_En bit. If the wake source has asserted a wake event, the associated PME Wake Status bit will be a "1". Bit[0] GP10 Bit[1] GP11 Bit[2] GP12 Bit[3] GP13 Bit[4] GP14 Bit[5] Reserved Bit[6] Reserved Bit[7] Reserved The PME Wake Status register is not affected by VCC POR, SOFT RESET or HARD RESET. Writing a "1" to Bit[7:0] will clear it. Writing a "0" to any bit in PME Wake Status Register has no effect.

NAME/DEFAULT	REGISTER OFFSET	DESCRIPTION
PME_STS2 Default = 0x00 on VTR POR	03 (R/W)	PME Wake Status Register 2 This register indicates the state of the individual PME wake sources, independent of the individual source enables or the PME_En bit. If the wake source has asserted a wake event, the associated PME Wake Status bit will be a "1". Bit[0] RI1 Bit[1] Reserved Bit[2] Reserved Bit[3] Reserved Bit[4] Reserved Bit[5] GP23 Bit[6] Reserved Bit[7] Reserved The PME Wake Status register is not affected by VCC POR, SOFT RESET or HARD RESET. Writing a "1" to Bit[7:0] will clear it. Writing a "0" to any bit in PME Wake Status Register has no effect.
Reserved Default = 0x00 on VTR POR	04 (R/W)	Reserved. Reads return 0.
PME_EN1 Default = 0x00 on VTR POR	05 (R/W)	PME Wake Enable Register 1 This register is used to enable individual LPC47N217 PME wake sources onto the IO_PME# wake bus. When the PME Wake Enable register bit for a wake source is active ("1"), if the source asserts a wake event so that the associated status bit is "1" and the PME_En bit is "1", the source will assert the IO_PME# signal. When the PME Wake Enable register bit for a wake source is inactive ("0"), the PME Wake Status register will indicate the state of the wake source but will not assert the IO_PME# signal. Bit[0] GP10 Bit[1] GP11 Bit[2] GP12 Bit[3] GP13 Bit[4] GP14 Bit[5] Reserved Bit[6] Reserved Bit[7] Reserved The PME Wake Enable register is not affected by VCC POR, SOFT RESET or HARD RESET.

NAME/DEFAULT	REGISTER OFFSET	DESCRIPTION
PME_EN2 Default = 0x00 on VTR POR	06 (R/W)	PME Wake Enable Register 2 This register is used to enable individual LPC47N217 PME wake sources onto the IO_PME# wake bus. When the PME Wake Enable register bit for a wake source is active ("1"), if the source asserts a wake event so that the associated status bit is "1" and the PME_En bit is "1", the source will assert the IO_PME# signal. When the PME Wake Enable register bit for a wake source is inactive ("0"), the PME Wake Status register will indicate the state of the wake source but will not assert the IO_PME# signal. Bit[0] RI1 Bit[1] Reserved Bit[2] Reserved Bit[3] Reserved Bit[4] Reserved Bit[5] GP23 Bit[6] Reserved Bit[7] Reserved The PME Wake Enable register is not affected by VCC POR, SOFT RESET or HARD RESET.
Reserved Default = 0x00 on VTR POR	07 (R/W)	Reserved. Reads return 0.
SMI_STS1 Default = 0x00 on VTR POR	08 (R/W)	SMI Status Register 1 This register is used to read the status of the SMI inputs. The following bits are cleared on a write of '1'. Bit[0] GP10 Bit[1] GP11 Bit[2] GP12 Bit[3] GP13 Bit[4] GP14 Bit[5] Reserved Bit[6] Reserved Bit[7] Reserved
SMI_STS2 Default = 0x01 on VTR POR Bit 0 is set to '1' on VCC POR, VTR POR and HARD RESET	09 (R/W)	SMI Status Register 2 This register is used to read the status of the SMI inputs. The bits[3:0] must be cleared at their source. Bits[5:4] are cleared on a write of '1'. Bit[0] PINT. The parallel port interrupt defaults to '1' when the parallel port activate bit is cleared. When the parallel port is activated, PINT follows the nACK input. Bit[1] U2INT Bit[2] U1INT Bit[3] Reserved Bit[4] GP23 Bit[5] Reserved Bit[7:6] Reserved

NAME/DEFAULT	REGISTER OFFSET	DESCRIPTION
SMI_EN1 Default = 0x00 on VTR POR	0A (R/W)	SMI Enable Register 1 This register is used to enable the different interrupt sources onto the internal group nSMI signal. 1=Enable 0=Disable Bit[0] GP10 Bit[1] GP11 Bit[2] GP12 Bit[3] GP13 Bit[4] GP14 Bit[5] Reserved Bit[6] Reserved Bit[7] Reserved
SMI_EN2 Default = 0x00 on VTR POR	0B (R/W)	SMI Enable Register 2 This register is used to enable the different interrupt sources onto the internal group nSMI signal, and the internal group nSMI signal onto the IO_SMI# GPI/O pin or the serial IRQ stream on IRQ2. 1=Enable 0=Disable Bit[0] EN_PINT Bit[1] EN_U2INT Bit[2] EN_U1INT Bit[3] SMSC Reserved (See notes following table) Bit[4] GP23 Bit[5] Reserved Bit[6] EN_SMI_S (Enable group nSMI signal onto serial IRQ2) Bit[7] EN_SMI (Enable group nSMI signal onto IO_SMI# pin)
GP1 Default = 0x00 on VTR POR	0C R/W	General Purpose I/O Data Register 1 Bit[0]GP10 Bit[1]GP11 Bit[2]GP12 Bit[3]GP13 Bit[4]GP14 Bit[5] SMSC Reserved Bit[6] SMSC Reserved Bit[7] SMSC Reserved
GP2 Default = 0x00 on VTR POR	0D R/W	General Purpose I/O Data Register 2 Bit[0] SMSC Reserved Bit[1] SMSC Reserved Bit[2] SMSC Reserved Bit[3]GP23 Bit[4] SMSC Reserved Bit[7:5]Reserved

NAME/DEFAULT	REGISTER OFFSET	DESCRIPTION
SMSC Reserved Default = 0x00 on VTR POR	0E R/W	SMSC Reserved register (See Note) Bit[0] SMSC Reserved Bit[1] SMSC Reserved Bit[2] SMSC Reserved Bit[3] SMSC Reserved Bit[4] SMSC Reserved Bit[5] SMSC Reserved Bit[6] SMSC Reserved Bit[7] SMSC Reserved
GP4 Default = 0x00 on VTR POR	0F R/W	General Purpose I/O Data Register 4 Bit[0]GP40 Bit[1]GP41 Bit[2]GP42 Bit[3]GP43 Bit[4]GP44 Bit[5]GP45 Bit[6]GP46 Bit[7]GP47

Notes:

- “Reserved” bits return 0 on read.
- “SMSC Reserved” bits/registers are reserved for SMSC use only. Writing to these registers may cause unwanted results. SMSC Reserved bits should be written to their default value when updating the register they reside in.

Chapter 19 Configuration

The configuration of the LPC47N217 is programmed through hardware selectable Configuration Access Ports that appear when the chip is placed into the configuration state. The LPC47N217 logical device blocks, if enabled, will operate normally in the configuration state.

19.1 Configuration Access Ports

The Configuration Access Ports are the CONFIG PORT, the INDEX PORT, and the DATA PORT (Table 19.1). The base address of these registers is controlled by the GP11/SYSOPT pin and by the Configuration Port Base Address registers CR12 and CR13. To determine the configuration base address at power-up, the state of the GP11/SYSOPT pin is latched by the falling edge of a hardware reset. If the latched state is a 0, the base address of the Configuration Access Ports is located at address 0x02E; if the latched state is a 1, the base address is located at address 0x04E. The base address is relocatable via CR12 and CR13.

Table 19.1 - Configuration Access Ports

PORT NAME	SYSOPT = 0	SYSOPT = 1	TYPE
CONFIG PORT	0x02E	0x04E	WRITE
INDEX PORT	0x02E	0x04E	READ/WRITE (Note 19.1 , Note 19.2)
DATA PORT	INDEX PORT + 1		READ/WRITE (Note 19.1)

Note 19.1 The INDEX and DATA ports are active only when the LPC47N217 is in the configuration state.

Note 19.2 The INDEX PORT is only readable in the configuration state.

19.2 Configuration State

The configuration registers are used to select programmable chip options. The LPC47N217 operates in two possible states: the run state and the configuration state. After power up by default the chip is in the run state. To program the configuration registers, the configuration state must be explicitly enabled. Programming the configuration registers typically follows this sequence:

1. Enter the Configuration State,
2. Program the Configuration Register(s),
3. Exit the Configuration State.

19.2.1 Entering the Configuration State

To enter the configuration state write the Configuration Access Key to the CONFIG PORT. The Configuration Access Key is one byte of 55H data. The LPC47N217 will automatically activate the Configuration Access Ports following this procedure.

19.2.2 Configuration Register Programming

The LPC47N217 contains configuration registers CR00-CR39. After the LPC47N217 enters the configuration state, configuration registers can be programmed by first writing the register index number (00 - 39H) to the Configuration Select Register (CSR) through the INDEX PORT and then writing or reading the configuration register contents through the DATA PORT. Configuration register access remains enabled until the configuration state is explicitly exited.

19.2.3 Exiting the Configuration State

To exit the configuration state, write one byte of AAH data to the CONFIG PORT. The LPC47N217 will automatically deactivate the Configuration Access Ports following this procedure, at which point configuration register access cannot occur until the configuration state is explicitly re-enabled.

19.2.4 Programming Example

The following is a configuration register programming example written in Intel 8086 assembly language.

```

;-----
; ENTER CONFIGURATION STATE |
;-----
MOV    DX,02EH           ;SYSOPT = 0
MOV    AX,055H
OUT    DX,AL

;-----
; CONFIGURE REGISTER CR0-CRx |
;-----
MOV    DX,02EH
MOV    AL,00H
OUT    DX,AL           ;Point to CR0
MOV    DX,02FH
MOV    AL,3FH
OUT    DX,AL           ;Update CR0
;
MOV    DX,02EH
MOV    AL,01H
OUT    DX,AL           ;Point to CR1
MOV    DX,02FH
MOV    AL,9FH
OUT    DX,AL           ;Update CR1
;
; Repeat for all CRx registers
;
;-----
; EXIT CONFIGURATION STATE |
;-----
MOV    DX,02EH
MOV    AX,AAH
OUT    DX,AL

```

19.2.5 Configuration Select Register (CSR)

The Configuration Select Register can only be accessed when the LPC47N217 is in the configuration state. The CSR is located at the INDEX PORT address and must be initialized with configuration register index before the register can be accessed using the DATA PORT.

19.3 Configuration Registers Summary

The configuration registers are set to their default values at power up (Table 19.2) and are RESET as indicated in Table 19.2 and the register descriptions that follow.

Table 19.2 - Configuration Registers Summary

REGISTER INDEX	TYPE	HARD RESET (NOTE 19.3)	VCC POR	VTR POR	REGISTER
CR00	R/W	-	0x28	-	Valid Config Cycle
CR01	R/W	bit[7]=1	0x9C	-	PP Power/Mode/CR Lock
CR02	R/W	bit[7]=0	0x08	-	UART 1,2 Power
CR03	R/W	-	0x70	-	SMSC Reserved
CR04	R/W	-	0x00	-	PP and UART Miscellaneous
CR05	R/W	-	0x00	-	SMSC Reserved
CR06	R/W	-	0xFF	-	SMSC Reserved
CR07	R/W	bit[7:4]=0	0x00	-	Auto Power Mgmt
CR08	R/W	-	0x00	-	Reserved
CR09	R/W	-	0x00	-	Test 4
CR0A	R/W	bit[7:6]=0	0x00	-	ECP FIFO Threshold/IR MUX
CR0B	R/W	-	0x00	-	SMSC Reserved
CR0C	R/W	0x02	0x02	-	UART Mode
CR0D	R	-	0x7A	-	Device ID
CR0E	R	-	Revision	-	Revision ID
CR0F	R/W	-	0x00	-	Test 1
CR10	R/W	-	0x00	-	Test 2
CR11	R/W	-	0x00	-	Test 3
CR12	R/W	SYSOPT=0:0x2E SYSOPT=1:0x4E	-	-	Configuration Base Address 0
CR13	R/W	SYSOPT=0:0x00 SYSOPT=1:0x00	-	-	Configuration Base Address 1
CR14	R	-	-	-	SMSC Reserved
CR15	R	-	-	-	UART1 FCR Shadow
CR16	R	-	-	-	UART2 FCR Shadow
CR17	R/W	-	0x03	-	SMSC Reserved
CR18	R	-	0x00	-	Reserved
CR19	R	-	0x00	-	Reserved
CR1A	R	-	0x00	-	Reserved
CR1B	R	-	0x00	-	Reserved
CR1C	R	-	0x00	-	Reserved
CR1D	R	-	0x00	-	Reserved
CR1E	R	-	0x00	-	Reserved
CR1F	R/W	-	0x00	-	SMSC Reserved
CR20	R/W	-	0x3C	-	SMSC Reserved
CR21	R/W	-	0x00	-	EPP Timeout Select
CR22	R/W	-	0x00	-	ECP Software Select
CR23	R/W	-	0x00	-	Parallel Port Base Address
CR24	R/W	-	0x00	-	UART1 Base Address

REGISTER INDEX	TYPE	HARD RESET (NOTE 19.3)	VCC POR	VTR POR	REGISTER
CR25	R/W	-	0x00	-	UART2 Base Address
CR26	R/W	-	0x00	-	PP DMA Select
CR27	R/W	-	0x00	-	PP IRQ Select
CR28	R/W	-	0x00	-	UART IRQ Select
CR29	R/W	-	0x80	-	IRQIN1/HPMODE/SIRQ_CLKRUN_En
CR2A	R/W	-	0x00	-	IRQIN2
CR2B	R/W	-	0x00	-	SCE (FIR) Base Address
CR2C	R/W	-	0x00	-	SCE (FIR) DMA Select
CR2D	R/W	-	0x03	-	IR Half Duplex Timeout
CR2E	R/W	-	0x00	-	Software Select A
CR2F	R/W	-	0x00	-	Software Select B
CR30	R/W	-	0x00	-	Runtime Register Block Address
CR31	R/W	-	-	0x00	GPIO Direction Register 1
CR32	R/W	-	-	0x00	GPIO Polarity Register 1
CR33	R/W	-	-	0x00	GPIO Direction Register 2
CR34	R/W	-	-	0x00	GPIO Polarity Register 2
CR35	R/W	-	-	0x00	SMSC Reserved
CR36	R/W	-	-	0x00	Reserved
CR37	R/W	-	-	0x00	GPIO Direction Register 4
CR38	R/W	-	-	0x00	GPIO Polarity Register 4
CR39	R/W	-	-	0x80	GPIO Output Type Register

Note: The bits that control the direction, polarity and output buffer type of each GPIO also affect the alternate function on the GPIO.

Note 19.3 Hard Reset: PCI_RESET# pin asserted.

19.4 Configuration Registers Description

19.4.1 CR00

CR00 can only be accessed in the configuration state and after the CSR has been initialized to 00H.

Table 19.3 - CR00

VALID CONFIGURATION CYCLE		
Type: R/W		Default: 0x28 on VCC POR
BIT NO.	BIT NAME	DESCRIPTION
0-2	Reserved	Read Only. A read returns 0
3	SMSC Reserved	"SMSC Reserved" bits/registers are reserved for SMSC use only. The BIOS should set this bit to '0'
4,5,6	Reserved	Read only. A read returns bit 5 as a 1 and bits 4 and 6 as a 0.
7	Valid	A high level on this software controlled bit can be used to indicate that a valid configuration cycle has occurred. The control software must take care to set this bit at the appropriate times. Set to zero after power up. This bit has no effect on any other hardware in the chip.

19.4.2 CR01

CR01 can only be accessed in the configuration state and after the CSR has been initialized to 01H.

Table 19.4 - CR01

PP POWER/MODE/CR LOCK		
Type: R/W		Default: 0x9C on VCC POR; Bit[7] = 1 on HARD RESET
BIT NO.	BIT NAME	DESCRIPTION
0,1	Reserved	Read Only. A read returns "0".
2	Parallel Port Power (Note 19.4)	A high level on this bit, supplies power to the Parallel Port (Default). A low level on this bit puts the Parallel Port in low power mode.
3	Parallel Port Mode	Parallel Port Mode. A high level on this bit, sets the Parallel Port for Printer Mode (Default). A low level on this bit enables the Extended Parallel port modes. Refer to Bits 0 and 1 of CR4
4	Reserved	Read Only. A read returns "1".
5,6	Reserved	Read Only. A read returns "0".
7	Lock CRx	A high level on this bit enables the reading and writing of CR00 –CR39 (Default). A low level on this bit disables the reading and writing of CR00 –CR39. Note: once the Lock CRx bit is set to "0", this bit can only be set to "1" by a hard reset or power-up reset.

Note 19.4 Power Down bits disable the respective logical device and associated pins, however the power down bit does not disable the selected address range for the logical device. To disable the host address registers the logical device's base address must be set below 100h. Devices that are powered down but still reside at a valid I/O base address will participate in Plug-and-Play range checking.

19.4.3 CR02

CR02 can only be accessed in the configuration state and after the CSR has been initialized to 02H.

Table 19.5 - CR02

UART 1 AND 2 POWER		
Type: R/W		Default: 0x08 on VCC POR; Bit[7] = 0 on HARD RESET
BIT NO.	BIT NAME	DESCRIPTION
0-2	Reserved	Read Only. A read returns "0".
3	UART1 Power Down (Note 19.5)	A high level on this bit, allows normal operation of the Primary Serial Port (Default). A low level on this bit places the Primary Serial Port into Power Down Mode.
4-6	Reserved	Read Only. A read returns "0".
7	UART2 Power Down (Note 19.5)	A high level on this bit, allows normal operation of the Secondary Serial Port, including the SCE/FIR block (Default). A low level on this bit places the Secondary Serial Port including the SCE/FIR block into Power Down Mode.

Note 19.5 Power Down bits disable the respective logical device and associated pins, however the power down bit does not disable the selected address range for the logical device. To disable the host address registers the logical device's base address must be set below 100h. Devices that are powered down but still reside at a valid I/O base address will participate in Plug-and-Play range checking.

19.4.4 CR03

CR03 can only be accessed in the configuration state and after the CSR has been initialized to 03H.

Table 19.6 - CR03

SMSC RESERVED		
Type: R/W		Default: 0x70 on VCC POR
BIT NO.	BIT NAME	DESCRIPTION
0	Reserved	Read Only. A read returns 0.
1	SMSC Reserved	See Note below
2,3	Reserved	Read Only. A read returns 0.
4	SMSC Reserved	See Note 19.6
5	SMSC Reserved	See Note 19.6
6	SMSC Reserved	See Note 19.6
7	Reserved	Read Only. A read returns 0.

Note 19.6 "SMSC Reserved" bits/registers are reserved for SMSC use only. Writing to these registers may cause unwanted results. SMSC Reserved bits should be written to their default value when updating the register they reside in.

19.4.5 CR04

CR04 can only be accessed in the configuration state and after the CSR has been initialized to 04H.

Table 19.7 - CR04

PP AND UART MISCELLANEOUS				
Type: R/W			Default: 0x00 on VCC POR	
BIT NO.	BIT NAME	DESCRIPTION		
1,0	Parallel Port Extended Modes	Bit 1	Bit 0	If CR1 bit 3 is a low level then:
		0	0	Standard and Bi-directional Modes (SPP) (default)
		0	1	EPP Mode and SPP
		1	0	ECP Mode (Note 19.8)
1	1	ECP Mode & EPP Mode (Note 19.7, Note 19.8)		
2,3	SMSC Reserved	"SMSC Reserved" bits are reserved for SMSC use only. SMSC Reserved bits should be written to their default value when updating the register they reside in.		
4	MIDI 1 (Note 19.9)	Serial Clock Select Port 1: A low level on this bit disables MIDI support (default). A high level on this bit enables MIDI support.		
5	MIDI 2 (Note 19.9)	Serial Clock Select Port 2: A low level on this bit disables MIDI support (default). A high level on this bit enables MIDI support.		
6	EPP Type	0 = EPP 1.9 (default) 1 = EPP 1.7		
7	Reserved	Reserved - Read as 0.		

Note 19.7 In this mode, EPP can be selected through the ecr register of ECP as mode 100.

Note 19.8 In these modes, 2 drives can be supported directly, 3 or 4 drives must use external 4 drive support. SPP can be selected through the ecr register of ECP as mode 000.

Note 19.9 MIDI Support: The Musical Instrumental Digital Interface (MIDI) operates at 31.25Kbaud (+/-1%).

19.4.6 CR05

CR05 can only be accessed in the configuration state and after the CSR has been initialized to 05H.

Table 19.8 - CR05

SMSC RESERVED		
Type: R/W		Default: 0x00 on VCC POR
BIT NO.	BIT NAME	DESCRIPTION
0 - 7	SMSC Reserved	See Note 19.10

Note 19.10 "SMSC Reserved" bits/registers are reserved for SMSC use only. Writing to these registers may cause unwanted results.

19.4.7 CR06

CR06 can only be accessed in the configuration state and after the CSR has been initialized to 06H.

Table 19.9 - CR06

SMSC RESERVED		
Type: R/W		Default: 0xFF on VCC POR
BIT NO.	BIT NAME	DESCRIPTION
0 - 7	SMSC Reserved	See Note 19.11

Note 19.11 "SMSC Reserved" bits/registers are reserved for SMSC use only. Writing to these registers may cause unwanted results.

19.4.8 CR07

CR07 can only be accessed in the configuration state and after the CSR has been initialized to 07H. CR07 controls auto power management.

Table 10 – CR07

AUTO POWER MANAGEMENT		
Type: R/W		Default: 0x00 on VCC POR; Bits[7:4] = 0000 on HARD RESET
BIT NO.	BIT NAME	DESCRIPTION
0,1	SMSC Reserved	See Note 19.12 below.
2,3	Reserved	Read Only. A read returns 0.
4	Parallel Port Enable	This bit controls the AUTOPOWER DOWN feature of the Parallel Port. The function is: 0 = Auto powerdown disabled (default) 1 = Auto powerdown enabled This bit is reset to the default state by POR or a hardware reset.

AUTO POWER MANAGEMENT		
Type: R/W		Default: 0x00 on VCC POR; Bits[7:4] = 0000 on HARD RESET
BIT NO.	BIT NAME	DESCRIPTION
5	UART 2 Enable	This bit controls the AUTOPOWER DOWN feature of the UART2. The function is: 0 = Auto powerdown disabled (default) 1 = Auto powerdown enabled This bit is reset to the default state by POR or a hardware reset.
6	UART 1 Enable	This bit controls the AUTOPOWER DOWN feature of the UART1. The function is: 0 = Auto powerdown disabled (default) 1 = Auto powerdown enabled This bit is reset to the default state by POR or a hardware reset.
7	SMSC Reserved	See Note below

Note 19.12 “SMSC Reserved” bits/registers are reserved for SMSC use only. Writing these bits to a value other than the default may cause unwanted results.

19.4.9 CR08

Register CR08 is reserved. The default value of this register after power up is 00H.

19.4.10 CR09

CR09 can only be accessed in the configuration state and after the CSR has been initialized to 09H. CR09 is a test control register and all bits must be treated as Reserved. Note: all test modes are reserved for SMSC use. Activating test mode registers may produce undesired results.

Table 19.11 - CR09

TEST 4		
Type: R/W		Default: 0x00 on VCC POR
BIT NO.	BIT NAME	DESCRIPTION
0	Test 24	RESERVED FOR SMSC USE
1	Test 25	
2	Test 26	
3	Test 27	
4	Test 28	
5	Test 29	
6	Test 30	
7	Test 31	

19.4.11 CR0A

CR0A can only be accessed in the configuration state and after the CSR has been initialized to 0AH. CR0A defines the FIFO threshold for the ECP mode parallel port. Bits [5:4] are Reserved. Reserved Bits cannot be written and return 0 when read. Bits [7:6] are the IR OUTPUT MUX bits and are reset to the default state by a POR and a hardware reset.

Table 19.12 - CR0A

ECP FIFO THRESHOLD/IR MUX			
Type: R/W		Default: 0x00 on VCC POR; Bits[7:6] = 00 on HARD RESET	
BIT NO.	BIT NAME	DESCRIPTION	
0	THR0	ECP FIFO Threshold 0.	
1	THR1	ECP FIFO Threshold 1.	
2	THR2	ECP FIFO Threshold 2.	
3	THR3	ECP FIFO Threshold 3.	
4,5	Reserved	Read Only. A read returns 0.	
6,7	IR Output Mux	These bits are used to select IR Output Mux Mode.	
		BIT7	BIT6
		0	0
		0	1
		1	0
		1	1
			MUX MODE
			Reserved
			Active device to IR port. That is, use IRRX2, IRTX2 (pins 37, 38). When Serial Port 2 is inactive (Power Down bit = 0), then IRTX2 pin is low.
			Reserved.
			Outputs Inactive: IRTX2 is High-Z, regardless of mode of UART2 and state of UART2 powerdown bit.

19.4.12 CR0B

CR0B can only be accessed in the configuration state and after the CSR has been initialized to 0BH.

Table 19.13 - CR0B

SMSC RESERVED		
Type: R/W		Default: 0x00 on VCC POR
BIT NO.	BIT NAME	DESCRIPTION
0 - 7	SMSC Reserved	See Note 19.13

Note 19.13 "SMSC Reserved" bits/registers are reserved for SMSC use only. Writing to these registers may cause unwanted results.

19.4.13 CR0C

CR0C can only be accessed in the configuration state and after the CSR has been initialized to 0CH. CR0C controls the operating mode of the UART. This register is reset to the default state by a POR or a hardware reset.

Table 19.14 - CR0C

UART MODE		
Type: R/W		Default: 0x02 on VCC POR and HARD RESET
BIT NO.	BIT NAME	DESCRIPTION
0	UART 2 RCV Polarity	0 = RX input active high (default). 1 = RX input active low.
1	UART 2 XMIT Polarity	0 = TX output active high. 1 = TX output active low (default).
2	UART 2 Duplex	This bit is used to define the FULL/HALF DUPLEX operation of UART 2. 1 = Half duplex 0 = Full duplex (default)
3, 4, 5	UART 2 MODE	<u>UART 2 Mode</u> <u>5 4 3</u> 0 0 0 Standard COM Functionality (default) 0 0 1 IrDA (HPSIR) 0 1 0 Amplitude Shift Keyed IR 0 1 1 Reserved 1 x x Reserved
6	UART 1 Speed	This bit enables the high speed mode of UART 1. 1 = High speed enabled 0 = Standard (default)
7	UART 2 Speed	This bit enables the high speed mode of UART 2. 1 = High speed enabled 0 = Standard (default)

19.4.14 CR0D

CR0D can only be accessed in the configuration state and after the CSR has been initialized to 0DH. This register is read only. CR0D contains the LPC47N217 Device ID. The default value of this register after power up is 7Ah on VCC POR.

19.4.15 CR0E

CR0E can only be accessed in the configuration state and after the CSR has been initialized to 0EH. This register is read only. CR0E contains the current LPC47N217 Chip Revision Level starting at 00H.

19.4.16 CR0F

CR0F can only be accessed in the configuration state and after the CSR has been initialized to 0FH. CR0F is a test control register and all bits must be treated as Reserved. Note: all test modes are reserved for SMSC use. Activating test mode registers may produce undesired results.

Table 19.15 - CR0F

TEST 1		
Type: R/W		Default: 0x00 on VCC POR
BIT NO.	BIT NAME	DESCRIPTION
0	Test 0	RESERVED FOR SMSC USE
1	Test 1	
2	Test 2	
3	Test 3	
4	Test 4	
5	Test 5	
6	Test 6	
7	Test 7	

19.4.17 CR10

CR10 can only be accessed in the configuration state and after the CSR has been initialized to 10H. CR10 is a test control register and all bits must be treated as Reserved. NOTE: All test modes are reserved for SMSC use. Activating test mode registers may produce undesired results.

Table 19.16 - CR10

TEST 2		
Type: R/W		Default: 0x00 on VCC POR
BIT NO.	BIT NAME	DESCRIPTION
0	Test 8	RESERVED FOR SMSC USE
1	Test 9	
2	Test 10	
3	Test 11	
4	Test 12	
5	Test 13	
6	Test 14	
7	Test 15	

19.4.18 CR11

CR11 can only be accessed in the configuration state and after the CSR has been initialized to 11H. CR11 is a test control register and all bits must be treated as Reserved.

Note: All test modes are reserved for SMSC use. Activating test mode registers may produce undesired results.

Table 19.17 - CR11

TEST 3		
Type: R/W		Default: 0x00 on VCC POR
BIT NO.	BIT NAME	DESCRIPTION
0	Test 16	RESERVED FOR SMSC USE
1	Test 17	
2	Test 18	
3	Test 19	
4	Test 20	
5	Test 21	
6	Test 22	
7	Test 23	

19.4.19 CR12 - CR13

CR12 and CR13 are the LPC47N217 Configuration Ports base address registers (Table 19.18 and Table 19.19). These registers are used to relocate the Configuration Ports base address beyond the power-up defaults determined by the SYSOPT pin programming.

CR12 contains the Configuration Ports base address bits A[7:0]. CR13 contains the Configuration Ports base address bits A[10:8]. The address bits A[15:11] must be '00000' to access the configuration port.

The Configuration Ports base address is relocatable on even-byte boundaries; i.e., A0 = '0'.

At power-up the Configuration Ports base address is determined by the SYSOPT pin programming. To relocate the Configuration Ports base address after power-up, first write the lower address bits of the new base address to CR12 and then write the upper address bits to CR13.

Note: Writing CR13 changes the Configuration Ports base address.

Table 19.18 - CR12

CONFIGURATION PORTS BASE ADDRESS BYTE 0 (NOTE 19.14)		
Type: R/W		Default: 0x2E (SYSOPT=0) 0x4E (SYSOPT=1) on VCC POR and HARD RESET
BIT NO.	BIT NAME	DESCRIPTION
0	Reserved	Read Only. A read returns 0.
1	A1	Configuration Ports Base Address Byte 0 for decoder.
2	A2	
3	A3	
4	A4	
5	A5	
6	A6	
7	A7	

Note 19.14 The Configuration Ports Base Address is relocatable on even-byte boundaries; i.e., A0 = "0".

Table 19.19 - CR13

CONFIGURATION PORTS BASE ADDRESS BYTE 1 (NOTE 19.15)		
Type: R/W		Default: 0x00 (SYSOPT=0) 0x00 (SYSOPT=1) on VCC POR and HARD RESET
BIT NO.	BIT NAME	DESCRIPTION
0	A8	Configuration Ports Base Address Byte 1 for decoder.
1	A9	
2	A10	
3-7	Reserved	Read Only. A read returns 0.

Note 19.15 Writing CR13 changes the Configuration Ports base address.

19.4.20 CR14

CR14 can only be accessed in the configuration state and after the CSR has been initialized to 14H.

Table 19.20 - CR14

SMSC RESERVED		
Type: R		Default: N/A
BIT NO.	BIT NAME	DESCRIPTION
0 - 7	SMSC Reserved	See Note below

Note 19.16 "SMSC Reserved" bits/registers are reserved for SMSC use only.

19.4.21 CR15

CR15 can only be accessed in the configuration state and after the CSR has been initialized to 15H. CR15 shadows the bits in the write-only UART1 run-time FCR register.

Table 19.21 - CR15

UART1 FCR SHADOW REGISTER				
Type: R/W			Default: N/A	
BIT NO.	BIT NAME	DESCRIPTION		
0	FIFO Enable	Setting this bit to a logic "1" enables both the XMIT and RCVR FIFOs		
1	RCVR FIFO Reset	Setting this bit to a logic "1" clears all bytes in the RCVR FIFO and resets its counter logic to 0. This bit is self clearing.		
2	XMIT FIFO Reset	Setting this bit to a logic "1" clears all bytes in the XMIT FIFO and resets its counter logic to 0. This bit is self-clearing.		
3	DMA Mode Select	Writing to this bit has no effect on the operation of the UART.		
4,5	Reserved	Read Only. A read returns 0.		
6,7	RCVR Trigger	These bits are used to set the trigger level for the RCVR FIFO interrupt.		
		BIT7	BIT6	RCVR FIFO Trigger Level (BYTES)
		0	0	1
		0	1	4
		1	0	8
		1	1	14

19.4.22 CR16

CR16 can only be accessed in the configuration state and after the CSR has been initialized to 16H. CR16 shadows the bits in the write-only UART2 run-time FCR register. See CR15 for register description.

19.4.23 CR17

CR17 can only be accessed in the configuration state and after the CSR has been initialized to 17H.

Table 19.22 - CR17

SMSC RESERVED		
Type: R/W		Default: 0x03 on VCC POR
BIT NO.	BIT NAME	DESCRIPTION
0-2	SMSC Reserved	See Note 19.17
3-7	Reserved	Read Only. A read returns 0.

Note 19.17 "SMSC Reserved" bits/registers are reserved for SMSC use only. Writing to these registers may cause unwanted results. SMSC Reserved bits should be written to their default value when updating the register they reside in, unless otherwise specified.

19.4.24 CR18 - CR1E

CR18 - CR1E registers are reserved. Reserved registers cannot be written and return 0 when read. The default value of these registers after power up is 00H on VCC POR.

19.4.25 CR1F

CR1F can only be accessed in the configuration state and after the CSR has been initialized to 1FH.

Table 19.23 - CR1F

SMSC RESERVED		
Type: R/W		Default: 0x00 on VCC POR
BIT NO.	BIT NAME	DESCRIPTION
0-7	SMSC Reserved	See Note 19.18

Note 19.18 “SMSC Reserved” bits/registers are reserved for SMSC use only. Writing to these registers may cause unwanted results. SMSC Reserved bits should be written to their default value when updating the register they reside in, unless otherwise specified.

19.4.26 CR20

CR20 can only be accessed in the configuration state and after the CSR has been initialized to 20H.

Table 19.24 - CR20

SMSC RESERVED		
Type: R/W		Default: 0x3C on VCC POR
BIT NO.	BIT NAME	DESCRIPTION
0	Reserved	Read Only. A read returns 0.
1	Reserved	Read Only. A read returns 0.
2-7	SMSC Reserved	See Note 19.19

Note 19.19 “SMSC Reserved” bits/registers are reserved for SMSC use only. Writing to these registers may cause unwanted results. SMSC Reserved bits should be written to their default value when updating the register they reside in, unless otherwise specified.

19.4.27 CR21

CR21 can only be accessed in the configuration state and after the CSR has been initialized to 21H.

Table 19.25 - CR21

EPP TIMEOUT SELECT		
Type: R/W		Default: 0x00 on VCC POR
BIT NO.	BIT NAME	DESCRIPTION
0,1	SMSC Reserved	See Note 19.20
2	TIMEOUT_SELECT	This bit selects the means of clearing the TIMEOUT bit in the EPP Status register. If the TIMEOUT_SELECT bit is cleared ('0'), the TIMEOUT bit is cleared on the trailing edge of the read of the EPP Status Register (default). If the TIMEOUT_SELECT bit is set ('1'), the TIMEOUT bit is cleared on a write of '1' to the TIMEOUT bit.
3-7	Reserved	Read Only. A read returns 0.

Note 19.20 "SMSC Reserved" bits/registers are reserved for SMSC use only. Writing to these registers may cause unwanted results. SMSC Reserved bits should be written to their default value when updating the register they reside in, unless otherwise specified.

19.4.28 CR22

The ECP Software Select register CR22 contains the ECP IRQ Select bits and the ECP DMA Select bits. CR22 is part of the ECP DMA/IRQ Software Indicators described in the ECP cnfgB register. CR22 is read/write.

Note: All of the ECP DMA/IRQ Software Indicators, including CR22, are software-only. Writing these bits does not affect the ECP hardware DMA or IRQ channels that are configured in CR26 and CR27.

Table 19.26 - CR22

ECP SOFTWARE SELECT REGISTER		
Type: R/W		Default: 0x00 on VCC POR
BIT NO.	BIT NAME	DESCRIPTION
2:0	ECP DMA Select	ECP DMA software Indicator
5:3	ECP IRQ Select	ECP IRQ Software Indicator
6,7	Reserved	Read Only. A read returns 0.

19.4.29 CR23

CR23 can only be accessed in the configuration state and after the CSR has been initialized to 23H. CR23 is used to select the base address of the parallel port. If EPP is not enabled, the parallel port can be set to 192 locations on 4-byte boundaries from 100H - 3FCH; if EPP is enabled, the parallel port can be set to 96 locations on 8-byte boundaries from 100H - 3F8H. To disable the parallel port, set ADR9 and ADR8 to zero.

Parallel Port Address Decoding: address bits A[15:10] must be '000000' to access the Parallel Port when in Compatible, Bi-directional, or EPP modes. A10 is active when in ECP mode.

Table 19.27 - CR23

PARALLEL PORT BASE ADDRESS		
Type: R/W		Default: 0x00 on VCC POR
BIT NO.	BIT NAME	DESCRIPTION
0	ADR2	Parallel Port Base Address bits for decoder.
1	ADR3	
2	ADR4	
3	ADR5	
4	ADR6	
5	ADR7	
6	ADR8	
7	ADR9	

Table 19.28 - Parallel Port Addressing Options

EPP ENABLED	ADDRESSING (LOW BITS) DECODE
No	A[1:0] = XXb
Yes	A[2:0] = XXXb

19.4.30 CR24

CR24 can only be accessed in the configuration state and after the CSR has been initialized to 24H. CR24 is used to select the base address of Serial Port 1 (UART1). The serial port can be set to 96 locations on 8-byte boundaries from 100H - 3F8H. To disable Serial Port 1, set ADR9 and ADR8 to zero. Set CR24.0 to 0 when writing the UART1 Base Address.

Serial Port 1 Address Decoding: address bits A[15:10] must be '000000' to access UART1 registers. A[2:0] are decoded as XXXb.

Table 19.29 - CR24

UART1 BASE ADDRESS REGISTER		
Type: R/W		Default: 0x00 on VCC POR
BIT NO.	BIT NAME	DESCRIPTION
0	Reserved	Read Only. A read returns 0.
1	ADR3	Serial Port 1 Base Address bits for decoder.
2	ADR4	
3	ADR5	

UART1 BASE ADDRESS REGISTER		
Type: R/W		Default: 0x00 on VCC POR
BIT NO.	BIT NAME	DESCRIPTION
4	ADR6	
5	ADR7	
6	ADR8	
7	ADR9	

19.4.31 CR25

CR25 can only be accessed in the configuration state and after the CSR has been initialized to 25H. CR25 is used to select the base address of Serial Port 2 (UART2). Serial Port 2 can be set to 96 locations on 8-byte boundaries from 100H - 3F8H. To disable Serial Port 2, set ADR9 and ADR8 to zero. Set CR25.0 to 0 when writing the UART2 Base Address.

Serial Port 2 Address Decoding: address bits A[15:10] must be '000000' to access UART2 registers. A[2:0] are decoded as XXXb.

Note: Serial Port 2 is used to support the IR functions in the device

Table 19.30 - CR25

UART2 BASE ADDRESS REGISTER		
Type: R/W		Default: 0x00 on VCC POR
BIT NO.	BIT NAME	DESCRIPTION
0	Reserved	Read Only. A read returns 0.
1	ADR3	Serial Port 2 Base Address bits for decoder.
2	ADR4	
3	ADR5	
4	ADR6	
5	ADR7	
6	ADR8	
7	ADR9	

19.4.32 CR26

CR26 can only be accessed in the configuration state and after the CSR has been initialized to 26H. CR26 is used to select the DMA for the Parallel Port (bits 0 - 3). Any unselected DMA Request output (DRQ) is in tristate.

Table 19.31 - CR26

PP DMA SELECTION REGISTER		
Type: R/W		Default: 0x00 on VCC POR
BIT NO.	BIT NAME	DESCRIPTION
3:0	PP DMA Select	These bits are used to select DMA for Parallel Port.
7:4	SMSC Reserved	See Note 19.21

Note 19.21 “SMSC Reserved” bits/registers are reserved for SMSC use only. Writing to these registers may cause unwanted results. SMSC Reserved bits should be written to their default value when updating the register they reside in, unless otherwise specified.

Table 19.32 - DMA Selection

BITS[3:0]	DMA SELECTED
0000	RESERVED
0001	DMA1
0010	DMA2
0011	DMA3
0100	RESERVED
....
....
1110	RESERVED
1111	NONE

19.4.33 CR27

CR27 can only be accessed in the configuration state and after the CSR has been initialized to 27H. CR27 is used to select the IRQ for the Parallel Port (bits 3 - 0). Any unselected IRQ output (registers CR27 - CR29) is in tri-state.

Table 19.33 - CR27

PP IRQ SELECTION REGISTER		
Type: R/W		Default: 0x00 on VCC POR
BIT NO.	BIT NAME	DESCRIPTION
3:0	PP IRQ Select	These bits are used to select IRQ for Parallel Port.
7:4	SMSC Reserved	See Note 19.22

Note 19.22 “SMSC Reserved” bits/registers are reserved for SMSC use only. Writing to these registers may cause unwanted results. SMSC Reserved bits should be written to their default value when updating the register they reside in, unless otherwise specified.

Table 19.34 - IRQ Encoding

BITS[3:0]	IRQ SELECTED
0000	NONE
0001	IRQ_1
0010	IRQ_2
0011	IRQ_3
0100	IRQ_4
0101	IRQ_5
0110	IRQ_6
0111	IRQ_7
1000	IRQ_8
1001	IRQ_9
1010	IRQ_10
1011	IRQ_11
1100	IRQ_12
1101	IRQ_13
1110	IRQ_14
1111	IRQ_15

19.4.34 CR28

CR28 can only be accessed in the configuration state and after the CSR has been initialized to 28H. CR28 is used to select the IRQ for Serial Port 1 (bits 7 - 4) and for Serial Port 2 (bits 3 - 0). Refer to the IRQ encoding for CR27 (Table 19.34). Any unselected IRQ output (registers CR27 - CR29) is in tristate. Shared IRQs are not supported in the LPC47N217.

Table 19.35 - CR28

UART INTERRUPT SELECTION		
Type: R/W		Default: 0x00 on VCC POR
BIT NO.	BIT NAME	DESCRIPTION
3:0	UART2 IRQ Select	These bits are used to select IRQ for Serial Port 2. See IRQ encoding for CR27 (Table 19.34).
7:4	UART1 IRQ Select	These bits are used to select IRQ for Serial Port 1. See IRQ encoding for CR27 (Table 19.34).

Table 19.36 - UART Interrupt Operation

UART1		UART2		IRQ PINS	
UART1 OUT2 BIT	UART1 IRQ OUTPUT STATE	UART2 OUT2 BIT	UART2 IRQ OUTPUT STATE	UART1 PIN STATE	UART2 PIN STATE
0	Z	0	Z	Z	Z
1	asserted	0	Z	1	Z
1	de-asserted	0	Z	0	Z
0	Z	1	asserted	Z	1
0	Z	1	de-asserted	Z	0
1	asserted	1	asserted	1	1

UART1		UART2		IRQ PINS	
UART1 OUT2 BIT	UART1 IRQ OUTPUT STATE	UART2 OUT2 BIT	UART2 IRQ OUTPUT STATE	UART1 PIN STATE	UART2 PIN STATE
1	asserted	1	de-asserted	1	0
1	de-asserted	1	asserted	0	1
1	de-asserted	1	de-asserted	0	0

It is the responsibility of the software to ensure that two IRQ's are not set to the same IRQ number. Potential damage to chip may result.

Note: Z = Don't Care.

19.4.35 CR29

CR29 can only be accessed in the configuration state and after the CSR has been initialized to 29H. CR29 controls the HPMODE bit and is used to select the IRQ mapping (bits 0 - 3) for the IRQIN1 pin. Refer to IRQ encoding for CR27 (Table 19.34). Any unselected IRQ output (registers CR27 - CR29) is in tristate.

Table 19.37 - CR29

IRQIN1/HPMODE/SIRQ_CLKRUN_EN		
Type: R/W		Default: 0x80 on VCC POR
BIT NO.	BIT NAME	DESCRIPTION
0-3	IRQIN1	Selects the IRQ for IRQIN1. (See Application Note in the "Routable IRQ Inputs" section)
4	HPMODE	See Figure 10.1 - Infrared Interface Block Diagram
		0 Select IRMODE (default)
		1 Select IRRX3
5-6	RESERVED	Not Writeable, Reads Return "0"
7	SIRQ_CLKRUN_EN	Serial IRQ and CLKRUN enable bit. 0 = Disable 1 = Enable (default)

19.4.36 CR2A

CR2A can only be accessed in the configuration state and after the CSR has been initialized to 2AH. CR2A is used to select the IRQ mapping (bits 0 - 3) for the IRQIN2 pin. Refer to IRQ encoding for CR27 (Table 19.34). Any unselected IRQ output (registers CR27 - CR29) is in tristate.

Table 19.38 - CR2A

IRQIN2		
Type: R/W		Default: 0x00 on VCC POR
BIT NO.	BIT NAME	DESCRIPTION
3:0	IRQIN2	Selects the IRQ for IRQIN2. (See Application Note in the "Routable IRQ Inputs" section)
7:4	Reserved	Read Only. A read returns 0.

19.4.37 CR2B

CR2B can only be accessed in the configuration state and after the CSR has been initialized to 2BH. CR2B is used to set the SCE (FIR) base address ADR[10:3]. The SCE base address can be set to 224 locations on 8-byte boundaries from 100H - 7F8H. To disable the SCE, set ADR10, ADR9 and ADR8 to zero.

SCE Address Decoding: address bits A[15:11] must be '00000' to access SCE registers. A[2:0] are decoded as XXXb.

Table 19.39 - CR2B

SCE (FIR) BASE ADDRESS REGISTER		
Type: R/W		Default: 0x00 on VCC POR
BIT NO.	BIT NAME	DESCRIPTION
0	ADR3	FIR Base Address bits for decoder.
1	ADR4	
2	ADR5	
3	ADR6	
4	ADR7	
5	ADR8	
6	ADR9	
7	ADR10	

19.4.38 CR2C

CR2C can only be accessed in the configuration state and after the CSR has been initialized to 2CH. Bits D[3:0] of this register are used to select the DMA for the SCE (FIR). Bits D[7:4] are Reserved. Reserved bits cannot be written and return 0 when read. Any unselected DMA Request output (DRQ) is in tristate.

Table 19.40 - CR2C

SCE (FIR) DMA SELECT REGISTER						
Type: R/W				Default: 0x00 on VCC POR		
BIT NO.	BIT NAME	DESCRIPTION				
3:0	DMA Select	BIT3	BIT2	BIT1	BIT0	DMA SELECTED
		0	0	0	0	RESERVED
		0	0	0	1	DMA1
		0	0	1	0	DMA2
		0	0	1	1	DMA3
		0	1	0	0	RESERVED
	
	
		1	1	1	0	RESERVED
		1	1	1	1	NONE
7:4	Reserved	Read Only. A read returns 0.				

19.4.39 CR2D

CR2D can only be accessed in the configuration state and after the CSR has been initialized to 2DH. CR2D is used to set the IR Half Duplex Turnaround Delay Time for the IR port. This value is 0 to 25.5msec in 100µsec increments.

The IRCC v2.0 block includes an 8 bit IR Half Duplex Time-out register in SCE Register Block 5, Address 1 that interacts with configuration register CR2D. These two registers behave like the other IRCC Legacy controls where either source uniformly updates the value of both registers when either register is explicitly written using IOW or following a device-level POR. IRCC software resets do not affect these registers.

The IR Half Duplex Time-out is programmable from 0 to 25.5mS in 100µS increments, as follows:

$$\text{IR HALF DUPLEX TIME-OUT} = (\text{CR2D}) \times 100\mu\text{S}$$

Table 19.41 - CR2D

IR HALF DUPLEX TIMEOUT		
Type: R/W		Default: 0x03 on VCC POR
BIT NO.	BIT NAME	DESCRIPTION
0-7	IR Half Duplex Time Out	These bits are used to set the IR Half Duplex Turnaround Delay Time for the IR port. This value is 0 to 25.5msec in 100µsec increments.

19.4.40 CR2E

CR2E can only be accessed in the configuration state and after the CSR has been initialized to 2EH. CR2E is directly connected to SCE Register Block Three, Address 0x05 in the IRCC v2.0 block.

Table 19.42 - CR2E

SOFTWARE SELECT A		
Type: R/W		Default: 0x00 on VCC POR
BIT NO.	BIT NAME	DESCRIPTION
0-7	Software Select A	These bits are directly connected to SCE Register Block Three, Address 0x05 in the IRCC v2.0 block.

19.4.41 CR2F

CR2F can only be accessed in the configuration state and after the CSR has been initialized to 2FH. CR2F is directly connected to SCE Register Block Three, Address 0x06 in the IRCC v2.0 block.

Table 19.43 - CR2F

SOFTWARE SELECT B		
Type: R/W		Default: 0x00 on VCC POR
BIT NO.	BIT NAME	DESCRIPTION
0-7	Software Select B	These bits are directly connected to SCE Register Block Three, Address 0x06 in the IRCC v2.0 block.

19.4.42 CR30

CR30 can only be accessed in the configuration state and after the CSR has been initialized to 30H. CR30 is used to set the Runtime Register Block base address ADR[11:4]. The Runtime Register Block base address can be set to 240 locations on 16-byte boundaries from 100H – FF0H. To disable Runtime Registers Block, set ADR11 – ADR8 to zero.

SCE Address Decoding: address bits A[15:12] must be '0000' to access Runtime Register Block registers. A[3:0] are decoded as XXXXb.

Table 19.44 - CR30

RUNTIME REGISTERS BLOCK BASE ADDRESS		
Type: R/W		Default: 0x00 on VCC POR
BIT NO.	BIT NAME	DESCRIPTION
0	ADR4	The bits in this register are used to program the location of the Runtime Register Block Base Address.
1	ADR5	
2	ADR6	
3	ADR7	
4	ADR8	
5	ADR9	
6	ADR10	
7	ADR11	

19.4.43 CR31

CR31 can only be accessed in the configuration state and after the CSR has been initialized to 31H. CR31 is GPIO Direction Register 1 and is used to select the direction of GP10-GP17 pins.

Table 19.45 - CR31

GPIO DIRECTION REGISTER 1		
Type: R/W		Default: 0x00 on VTR POR
BIT NO.	BIT NAME	DESCRIPTION
0	GP10	The bits in this register are used to select the direction of the GP10-GP14 pins. 0=Input 1=Output
1	GP11	
2	GP12	
3	GP13	
4	GP14	
5	SMSC Reserved	
6	SMSC Reserved	
7	SMSC Reserved	

Note: "SMSC Reserved" bits/registers are reserved for SMSC use only. Writing to these registers/bits may cause unwanted results. SMSC Reserved bits should be written to their default value when updating the register they reside in, unless otherwise specified.

19.4.44 CR32

CR32 can only be accessed in the configuration state and after the CSR has been initialized to 32H. CR32 is GPIO Polarity Register 1 and is used to select the polarity of GP10-GP17 pins.

Table 19.46 - CR32

GPIO POLARITY REGISTER 1		
Type: R/W		Default: 0x00 on VTR POR
BIT NO.	BIT NAME	DESCRIPTION
0	GP10	The bits in this register are used to select the polarity of the GP10-GP14 pins. 0=Non-Inverted 1=Inverted
1	GP11	
2	GP12	
3	GP13	
4	GP14	
5	Reserved	Reserved. This is a r/w bit that has no effect on the hardware.
6	Reserved	Reserved. This is a r/w bit that has no effect on the hardware.
7	Reserved	Reserved. This is a r/w bit that has no effect on the hardware.

19.4.45 CR33

CR33 can only be accessed in the configuration state and after the CSR has been initialized to 33H. CR33 is GPIO Direction Register 2. It is used to select the direction of GP23 pin, and select alternate function on GP23 and GP12 pins.

Table 19.47 - CR33

GPIO DIRECTION REGISTER 2		
Type: R/W		Default: 0x00 on VTR POR
BIT NO.	BIT NAME	DESCRIPTION
0-2	SMSC Reserved	See Note 19.23
3	GP23	This bit is used to select the direction of the GP23 pin. 0=Input 1=Output
4	SMSC Reserved	See note below.
5	Reserved	Read Only. A read returns 0.
6	SMSC Reserved	See note below.
7	GP12 Alternate. Function Select	0=GPIO 1=IO_SMI# Note: Selecting the IO_SMI# function with GP12 configured with non-inverted polarity will give an active low output signal. The output type can be programmed for open drain via CR39.

Note 19.23 "SMSC Reserved" bits/registers are reserved for SMSC use only. Writing to these registers/bits may cause unwanted results. SMSC Reserved bits should be written to their default value when updating the register they reside in, unless otherwise specified.

19.4.46 CR34

CR35 can only be accessed in the configuration state and after the CSR has been initialized to 34H. CR35 is GPIO Polarity Register 2. It is used to select the polarity of the GP23 and IO_PME pins, and select alternate function on GP13 and GP14 pins.

Table 19.48 - CR34

GPIO POLARITY REGISTER 2		
Type: R/W		Default: 0x00 on VTR POR
BIT NO.	BIT NAME	DESCRIPTION
0	Reserved	Reserved. This is a r/w bit that has no effect on the hardware.
1	Reserved	Reserved. This is a r/w bit that has no effect on the hardware.
2	Reserved	Reserved. This is a r/w bit that has no effect on the hardware.
3	GP23	This bit is are used to select the polarity of the GP23 pin. 0=Non-Inverted 1=Inverted
4	Reserved	Reserved. This is a r/w bit that has no effect on the hardware.
5	IO_PME# Polarity select	This bit is used to select the polarity of the IO_PME# pin. 0=Non-Inverted 1=Inverted Note: Configuring this pin function with non-inverted polarity will give an active low output signal. The output type can be either open drain or push-pull. (See CR39).
6	GP13 Alternate Function Select	0=GPIO (See Application Note in the “Routable IRQ Inputs” section) 1=IRQIN1
7	GP14 Alternate Function Select	0=GPIO (See Application Note in the “Routable IRQ Inputs” section) 1=IRQIN2

19.4.47 CR35

CR35 can only be accessed in the configuration state and after the CSR has been initialized to 35H.

Table 19.49 - CR35

SMSC RESERVED		
Type: R/W		Default: 0x00 on VTR POR
BIT NO.	BIT NAME	DESCRIPTION
0	SMSC Reserved	See Note 19.24

Note 19.24 “SMSC Reserved” bits/registers are reserved for SMSC use only. Writing to these registers/bits may cause unwanted results. SMSC Reserved bits should be written to their default value when updating the register they reside in, unless otherwise specified.

19.4.48 CR36

CR36 can only be accessed in the configuration state and after the CSR has been initialized to 36H.

Table 19.50 - CR36

RESERVED		
Type: R/W		Default: 0x00 on VTR POR
BIT NO.	BIT NAME	DESCRIPTION
0	Reserved	This is a r/w bit that has no effect on the hardware.
1	Reserved	This is a r/w bit that has no effect on the hardware.
2	Reserved	This is a r/w bit that has no effect on the hardware.
3	Reserved	This is a r/w bit that has no effect on the hardware.
4	Reserved	This is a r/w bit that has no effect on the hardware.
5	Reserved	This is a r/w bit that has no effect on the hardware.
6	Reserved	This is a r/w bit that has no effect on the hardware.
7	Reserved	This is a r/w bit that has no effect on the hardware.

19.4.49 CR37

CR37 can only be accessed in the configuration state and after the CSR has been initialized to 37H. CR37 is GPIO Direction Register 4 and is used to select the direction of GP40-GP47 pins.

Table 19.51 - CR37

GPIO DIRECTION REGISTER 4		
TYPE: R/W		DEFAULT: 0X00 ON VTR POR
BIT NO.	BIT NAME	DESCRIPTION
0	GP40	The bits in this register are used to select the direction of the GP40-GP47 pins. 0=Input 1=Output
1	GP41	
2	GP42	
3	GP43	
4	GP44	
5	GP45	
6	GP46	
7	GP47	

19.4.50 CR38

CR38 can only be accessed in the configuration state and after the CSR has been initialized to 38H. CR38 is GPIO Polarity Register 4 and is used to select the polarity of GP40-GP47 pins.

Table 19.52 - CR38

GPIO POLARITY REGISTER 4		
Type: R/W		Default: 0x00 on VTR POR
BIT NO.	BIT NAME	DESCRIPTION
0	GP40	The bits in this register are used to select the polarity of the GP40-GP47 pins. 0=Non-Inverted 1=Inverted
1	GP41	
2	GP42	
3	GP43	
4	GP44	
5	GP45	
6	GP46	
7	GP47	

19.4.51 CR39

CR39 can only be accessed in the configuration state and after the CSR has been initialized to 39H. CR39 is GPIO Output Register and is used to select the output buffer of GP12-GP17, GP20 and IO_PME# pins.

Table 19.53 - CR39

GPIO OUTPUT REGISTER		
TYPE: R/W		DEFAULT: 0X80 ON VTR POR
BIT NO.	BIT NAME	DESCRIPTION
0	GP12	The bits in this register are used to select the output buffer type of the GP12-GP14 and IO_PME# pins. 0=Push-pull 1=Open Drain
1	GP13	
2	GP14	
3	Reserved	
4	Reserved	
5	Reserved	
6	Reserved	
7	IO_PME#	

19.5 Logical Device Base I/O Address and Range

Table 19.54 - I/O Base Address Configuration Register Description

LOGICAL DEVICE	REGISTER INDEX	BASE I/O RANGE	FIXED BASE OFFSETS
Parallel Port	0x23	[0x0100:0x03FC] on 4-byte boundaries (EPP Not supported) or [0x0100:0x03F8] on 8-byte boundaries	+0 : Data/ecpAfifo +1 : Status +2 : Control +400h : cfifo/ecpDfifo/tfifo/cnfgA +401h : cnfgB +402h : ecr
		(all modes supported, EPP is only available when the base address is on an 8-byte boundary)	+3 : EPP Address +4 : EPP Data 0 +5 : EPP Data 1 +6 : EPP Data 2 +7 : EPP Data 3
Serial Port 1	0x24	[0x0100:0x03F8] on 8 byte boundaries	+0 : RB/TB/LSB div +1 : IER/MSB div +2 : IIR/FCR +3 : LCR +4 : MCR +5 : LSR +6 : MSR +7 : SCR
Serial Port 2	0x25	[0x0100:0x03F8] on 8-byte boundaries	+0 : RB/TB/LSB div +1 : IER/MSB div +2 : IIR/FCR +3 : LCR +4 : MCR +5 : LSR +6 : MSR +7 : SCR
	0x2B (FIR/CIR)	[0x100:0x07F8] on 8-byte boundaries	+0 : DR/SCEA/CIRC/IDH/(IRDACR/BOFH) +1 : INTID/SCEB/CIRCR/IDL/BOFL +2 : IER/FIFOT/CIRBR/CID/BWCL +3 : LSR/LSA/VERN/(BWCH/TDSH) +4 : LCA/(IRQL/DMAC)/TDSL +5 : LCB/RDSH +6 : BS/RDSL +7 : MCR
Runtime Register Block	0x30	[0x0100:0x0FF0] on 16-byte boundaries	+00 : PME_STS . . . +0F : GP4 (See Table 18.1 in the Runtime Registers section for Full List)

LOGICAL DEVICE	REGISTER INDEX	BASE I/O RANGE	FIXED BASE OFFSETS
Config. Port	0x12, 0x13 (Note 19.25)	[0x0100:0x07FE] On 2-byte boundaries	See Configuration Registers in Table 19.2. They are accessed through the index and DATA ports located at the Configuration Port address and the Configuration Port address +1 respectively.

Note 19.25 The Configuration Port is at either 0x02E or 0x04E (for SYSOPT=0 or SYSOPT=1) at power up and can be relocated via CR12 and CR13.

19.6 Note A. Logical Device IRQ and DMA Operation

1. IRQ and DMA Enable and Disable: Any time the IRQ or DMA channel for a logical block is disabled by a register bit in that logical block, the IRQ and/or DMA channel is disabled. This is in addition to the IRQ and DMA channel disabled by the Configuration Registers (active bit or address not valid).
 - a. Serial Ports:

Modem Control Register (MCR) Bit D2 (OUT2) - When OUT2 is a logic "0", the serial port interrupt is disabled.

Disabling DMA Enable bit, disables DMA for UART2. Refer to the IrCC specification.
 - b. Parallel Port:
 - I. SPP and EPP modes: Control Port (Base+2) bit D4 (IRQE) set to "0", IRQ is disabled.
 - ii. ECP Mode:
 - (1) (DMA) dmaEn from ecr register. See table below.
 - (2) IRQ - See table below.

MODE (FROM ECR REGISTER)		IRQ CONTROLLED BY	DMA CONTROLLED BY
000	PRINTER	IRQE	dmaEn
001	SPP	IRQE	dmaEn
010	FIFO	(on)	dmaEn
011	ECP	(on)	dmaEn
100	EPP	IRQE	dmaEn
101	RES	IRQE	dmaEn
110	TEST	(on)	dmaEn
111	CONFIG	IRQE	dmaEn

Chapter 20 Operational Description

20.1 Maximum Guaranteed Ratings

Operating Temperature Range	0°C to +70°C
Storage Temperature Range.....	-55° to +150°C
Lead Temperature Range	Refer to JEDEC Spec. J-STD-020
Positive Voltage on any pin, with respect to Ground	VCC+0.3V
Negative Voltage on any pin, with respect to Ground.....	-0.3V
Maximum VCC	+5.5V
Maximum VTR	+5.5V

Notes:

- Stresses above those listed above could cause permanent damage to the device. This is a stress rating only and functional operation of the device at any other condition above those indicated in the operation sections of this specification is not implied.
- When powering this device from laboratory or system power supplies, it is important that the Absolute Maximum Ratings not be exceeded or device failure can result. Some power supplies exhibit voltage spikes on their outputs when the AC power is switched on or off. In addition, voltage transients on the AC power line may appear on the DC output. If this possibility exists, it is suggested that a clamp circuit be used.

20.2 DC Electrical Characteristics

($T_A = 0^\circ\text{C} - 70^\circ\text{C}$, $V_{CC} = +3.3\text{ V} \pm 10\%$, $V_{TR} = +3.3\text{ V} \pm 10\%$)

PARAMETER	SYMBOL	MIN	TYP	MAX	UNITS	COMMENTS
I Type Input Buffer						
Low Input Level	V_{ILI}			0.8	V	TTL Levels
High Input Level	V_{IHI}	2.0			V	
IS Type Input Buffer						
Low Input Level	V_{ILIS}			0.8	V	Schmitt Trigger
High Input Level	V_{IHIS}	2.2			V	Schmitt Trigger
Schmitt Trigger Hysteresis	V_{HYS}		100		mV	
Input Leakage, I and IS Buffers						
Low Input Leakage	I_{IL}	-10		+10	μA	$V_{IN} = 0$
High Input Leakage	I_{IH}	-10		+10	μA	$V_{IN} = V_{CC}$

PARAMETER	SYMBOL	MIN	TYP	MAX	UNITS	COMMENTS
O6 Type Buffer						
Low Output Level	V_{OL}			0.4	V	$I_{OL} = 6\text{mA}$
High Output Level	V_{OH}	2.4			V	$I_{OH} = -3\text{mA}$
IO8 Type Buffer						
Low Output Level	V_{OL}			0.4	V	$I_{OL} = 8\text{mA}$
High Output Level	V_{OH}	2.4			V	$I_{OH} = -4\text{mA}$
Output Leakage	I_{OL}	-10		+10	μA	$V_{IN} = 0 \text{ to } V_{CC}$ (Note 20.1)
O8 Type Buffer						
Low Output Level	V_{OL}			0.4	V	$I_{OL} = 8\text{mA}$
High Output Level	V_{OH}	2.4			V	$I_{OH} = -4\text{mA}$
O12 Type Buffer						
Low Output Level	V_{OL}			0.4	V	$I_{OL} = 12\text{mA}$
High Output Level	V_{OH}	2.4			V	$I_{OH} = -6\text{mA}$
IO12 Type Buffer						
Low Output Level	V_{OL}			0.4	V	$I_{OL} = 12\text{mA}$
High Output Level	V_{OH}	2.4			V	$I_{OH} = -6\text{mA}$
Output Leakage	I_{OL}	-10		+10	μA	$V_{IN} = 0 \text{ to } V_{CC}$ (Note 20.1)
OD12 Type Buffer						
Low Output Level	V_{OL}			0.4	V	$I_{OL} = 12\text{mA}$
Output Leakage	I_{OL}	-10		+10	μA	$V_{IN} = 0 \text{ to } V_{CC}$
OD14 Type Buffer						
Low Output Level	V_{OL}			0.4	V	$I_{OL} = 14\text{mA}$
Output Leakage	I_{OL}	-10		+10	μA	$V_{IN} = 0 \text{ to } V_{CC}$
OP14 Type Buffer						
Low Output Level	V_{OL}			0.4	V	$I_{OL} = 14\text{mA}$
High Output Level	V_{OH}	2.4			V	$I_{OH} = -14\text{mA}$
Output Leakage	I_{OL}	-10		+10	μA	$V_{IN} = 0 \text{ to } V_{CC}$ (Note 20.1)

PARAMETER	SYMBOL	MIN	TYP	MAX	UNITS	COMMENTS
IOP14 Type Buffer						
Low Output Level	V_{OL}			0.4	V	$I_{OL} = 14\text{mA}$
High Output Level	V_{OH}	2.4			V	$I_{OH} = -14\text{mA}$
Output Leakage	I_{OL}	-10		+10	μA	$V_{IN} = 0$ to VCC (Note 20.1)
Backdrive Protect/ChiProtect (All pins excluding LAD[3:0], LDRQ#, LPCPD#, LFRAME#)	I_{IL}			± 10	μA	VCC = 0V $V_{IN} = 5.5\text{V Max}$
5V Tolerant Pins (All pins excluding LAD[3:0], LDRQ#, LPCPD#, LFRAME#) Inputs and Outputs in High Impedance State	I_{IL}			± 10	μA	VCC = 3.3V $V_{IN} = 5.5\text{V Max}$
LPC Bus Pins (LAD[3:0], LDRQ#, LPCPD#, LFRAME#)	I_{IL}			± 10	μA	VCC = 0V and VCC = 3.3V $V_{IN} = 3.6\text{V Max}$
VCC Supply Current Active	I_{CC}			17 (Note 20.2)	mA	All outputs open, all inputs transitioning from/to 0V to/from 3.3V
VTR Supply Current Active	I_{TR}			0.2 (Note 20.2, Note 20.3)	mA	All outputs open, all inputs transitioning from/to 0V to/from 3.3V

Note 20.1 All output leakage's are measured with all pins in high impedance

Note 20.2 These values are estimated. They will be updated after characterization. Contact SMSC for the latest values.

Note 20.3 Max I_{TR} with VCC = 3.3V (nominal) is 0.2mA.

Max I_{TR} with VCC = 0V (nominal) is 60 μA .

CAPACITANCE $T_A = 25^\circ\text{C}$; $f_c = 1\text{MHz}$; VCC = 3.3V $\pm 10\%$, VTR = 3.3V $\pm 10\%$

PARAMETER	SYMBOL	LIMITS			UNIT	TEST CONDITION
		MIN	TYP	MAX		
Clock Input Capacitance	C_{IN}			20	pF	All pins except pin under test tied to AC ground
Input Capacitance	C_{IN}			10	pF	
Output Capacitance	C_{OUT}			20	pF	

20.3 Valid Power States

The following table shows the valid power states for each power supply to the device.

POWER SUPPLY	POWER STATE		
	S0-S2	S3	S4-S5
VTR	On	On	On
VCC	On	Off	Off

Note: VCC must not be powered when VTR is off.

Chapter 21 Timing Diagrams

For the Timing Diagrams shown, the following capacitive loads are used on outputs.

NAME	CAPACITANCE TOTAL (PF)
SER_IRQ	50
nLAD[3:0]	50
LDRQ#	50
PD[0:7]	240
nSTROBE	240
nALF	240
SLCT	240
TXD1	50
CLKRUN#	50

21.1 Power-Up Timing

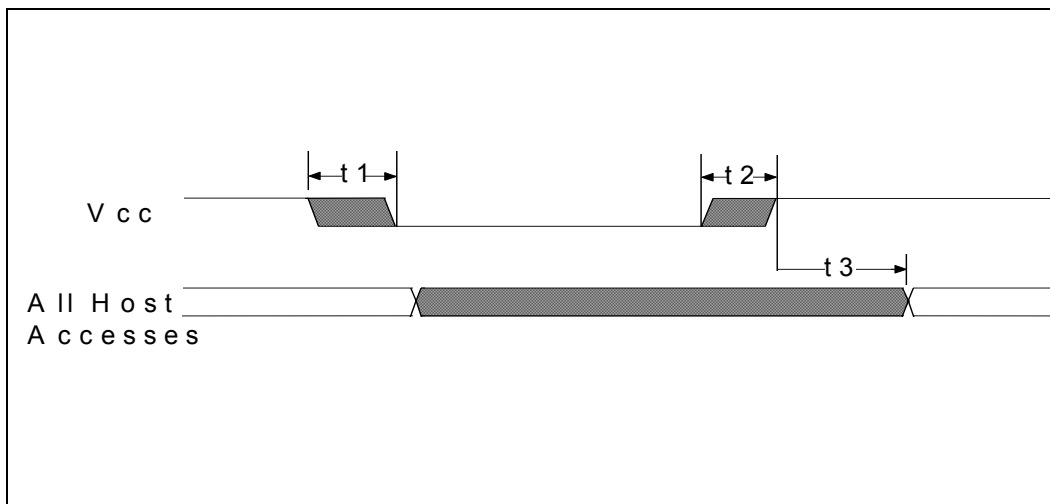

Figure 21.1 - Power-Up Timing

NAME	DESCRIPTION	MIN	TYP	MAX	UNITS
t1	VCC Slew from 2.7V to 0V	300			μ S
t2	VCC Slew from 0V to 2.7V	100			μ S
t3	All Host Accesses After Powerup (Note 21.1)	125		500	μ S

Note 21.1 Internal write-protection period after VCC passes 2.7 volts on power-up

21.2 Input Clock Timing

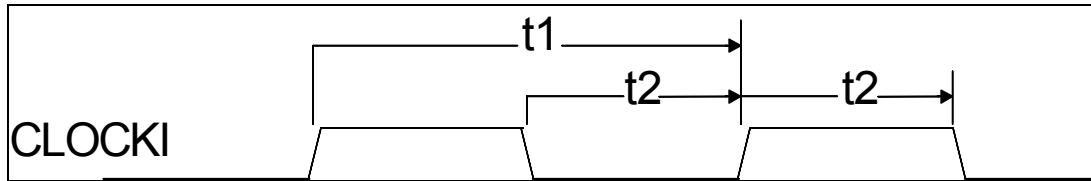

Figure 21.2 - Input Clock Timing

NAME	DESCRIPTION	MIN	TYP	MAX	UNITS
t1	Clock Cycle Time for 14.318MHZ		69.84		ns
t2	Clock High Time/Low Time for 14.318MHZ	20	35		ns
	Clock Rise Time/Fall Time (not shown)			5	ns

21.3 LPC Interface Timing

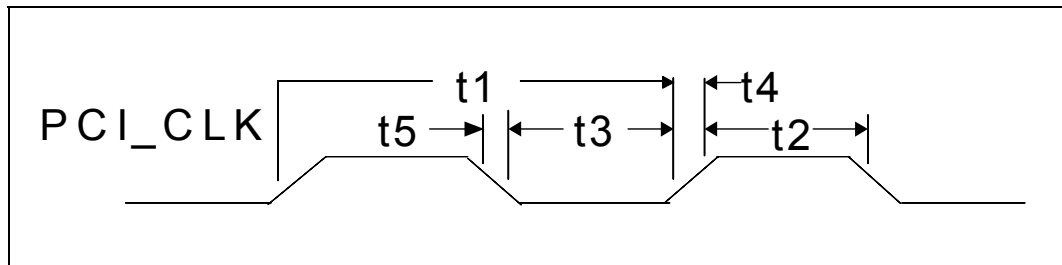

Figure 21.3 - PCI Clock Timing

NAME	DESCRIPTION	MIN	TYP	MAX	UNITS
t1	Period	30		33.3	nsec
t2	High Time	12			nsec
t3	Low Time	12			nsec
t4	Rise Time			3	nsec
t5	Fall Time			3	nsec

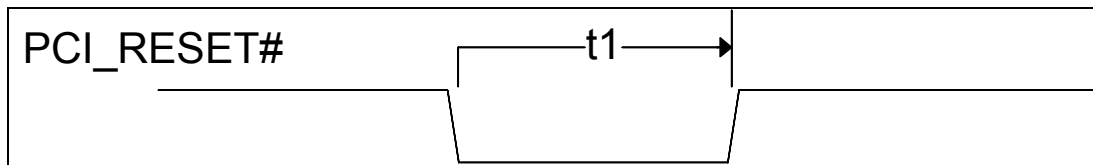

Figure 21.4 - Reset Timing

NAME	DESCRIPTION	MIN	TYP	MAX	UNITS
t1	PCI_RESET# width	1			ms

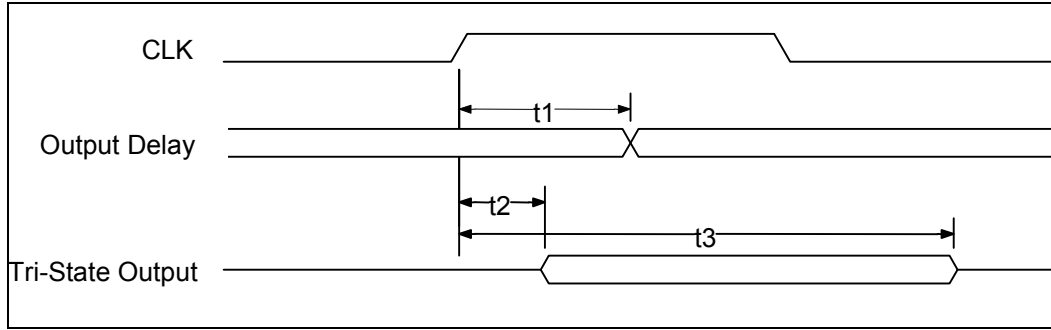

Figure 21.5 - Output Timing Measurement Conditions, LPC Signals

NAME	DESCRIPTION	MIN	TYP	MAX	UNITS
t1	CLK to Signal Valid Delay – Bused Signals	2		11	ns
t2	Float to Active Delay	2		11	ns
t3	Active to Float Delay			28	ns

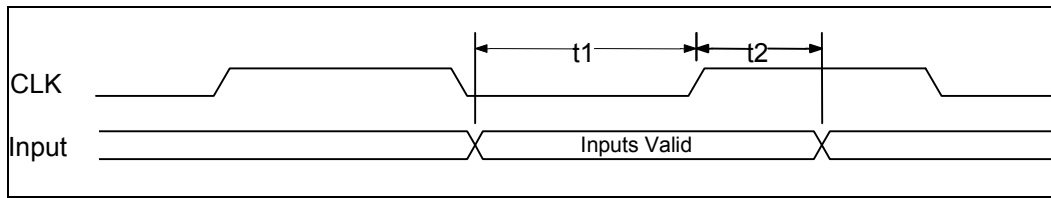
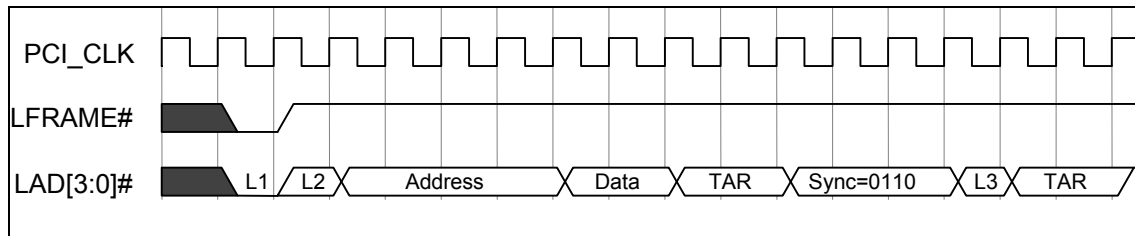

Figure 21.6 - Input Timing Measurement Conditions, LPC Signals

NAME	DESCRIPTION	MIN	TYP	MAX	UNITS
t1	Input Set Up Time to CLK – Bused Signals	7			ns
t2	Input Hold Time from CLK	0			ns



Note: L1=Start; L2=CYCTYP+DIR; L3=Sync of 0000

Figure 21.7 - I/O Write

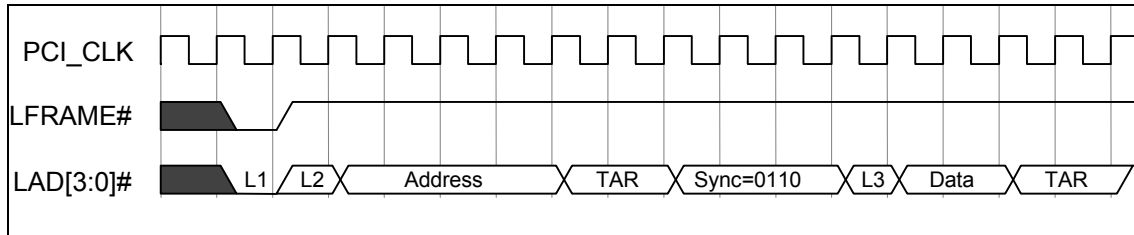

Note: L1=Start; L2=CYCTYP+DIR; L3=Sync of 0000

Figure 21.8 - I/O Read

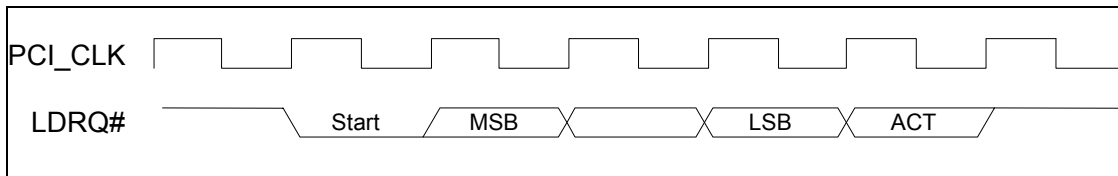
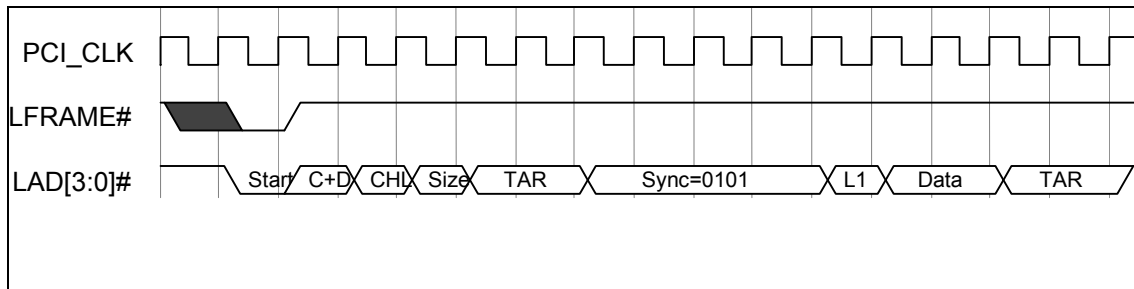
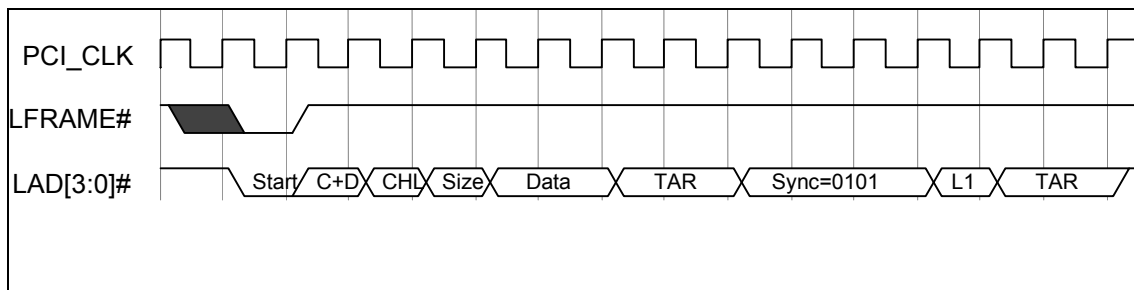

Figure 21.9 - DMA Request Assertion Through LDRQ#



Note: L1=Sync of 0000

Figure 21.10 - DMA Write (First Byte)



Note: L1=Sync of 0000

Figure 21.11 - DMA Read (First Byte)

21.4 Parallel Port Timing

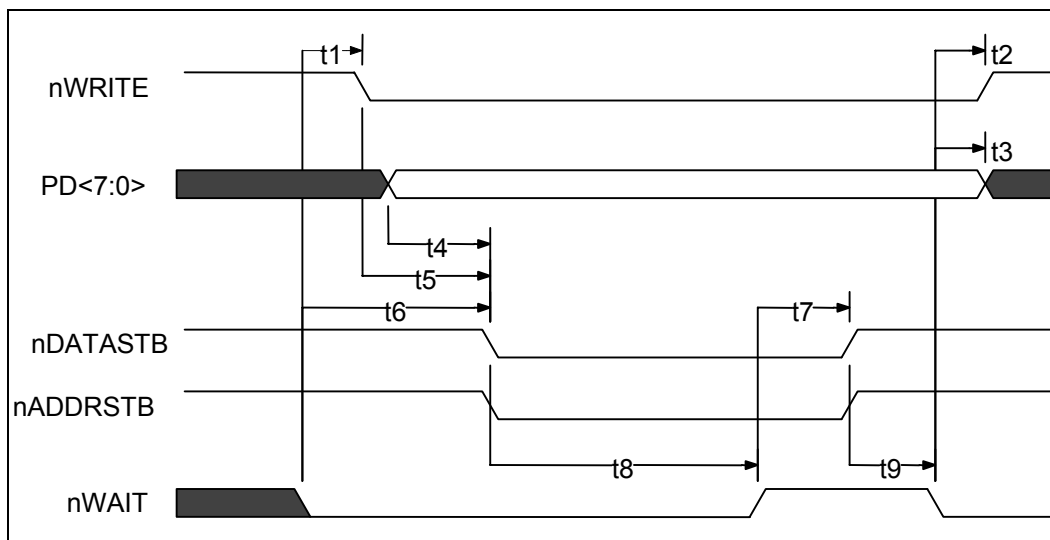
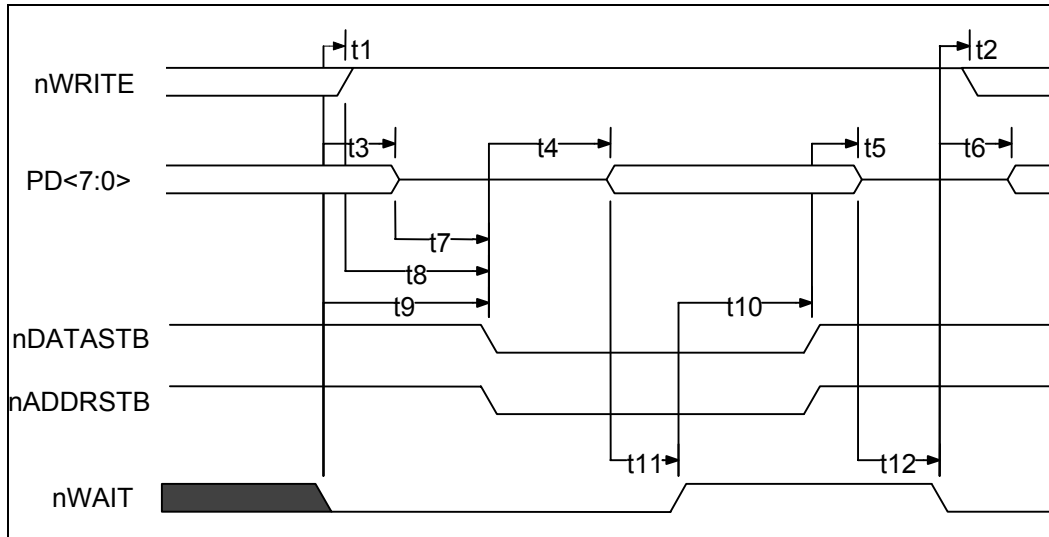

Figure 21.12 - EPP 1.9 Data or Address Write Cycle

NAME	DESCRIPTION	MIN	TYP	MAX	UNITS
t1	nWAIT Asserted to nWRITE Asserted (Note 21.2)	60		185	ns
t2	nWAIT Asserted to nWRITE Change (Note 21.2)	60		185	ns
t3	nWAIT Asserted to PDATA Invalid (Note 21.2)	0			ns
t4	PDATA Valid to Command Asserted	10			ns
t5	nWRITE to Command Asserted	5		35	ns
t6	nWAIT Asserted to Command Asserted (Note 21.2)	60		210	ns
t7	nWAIT Deasserted to Command Deasserted (Note 21.2)	60		190	ns
t8	Command Asserted to nWAIT Deasserted	0		10	μs
t9	Command Deasserted to nWAIT Asserted	0			ns

Note 21.2 nWAIT must be filtered to compensate for ringing on the parallel bus cable. WAIT is considered to have settled after it does not transition for a minimum of 50 nsec.

Figure 21.13 - EPP 1.9 Data or Address Read Cycle

NAME	DESCRIPTION	MIN	TYP	MAX	UNITS
t1	nWAIT Asserted to nWRITE Deasserted	0		185	ns
t2	nWAIT Asserted to nWRITE Modified (Note 21.3 , Note 21.4)	60		190	ns
t3	nWAIT Asserted to PDATA Hi-Z (Note 21.3)	60		180	ns
t4	Command Asserted to PDATA Valid	0			ns
t5	Command Deasserted to PDATA Hi-Z	0			ns
t6	nWAIT Asserted to PDATA Driven (Note 21.3)	60		190	ns
t7	PDATA Hi-Z to Command Asserted	0		30	ns
t8	nWRITE Deasserted to Command	1			ns
t9	nWAIT Asserted to Command Asserted	0		195	ns
t10	nWAIT Deasserted to Command Deasserted (Note 21.3)	60		180	ns
t11	PDATA Valid to nWAIT Deasserted	0			ns
t12	PDATA Hi-Z to nWAIT Asserted	0			µs

Note 21.3 nWAIT is considered to have settled after it does not transition for a minimum of 50 ns.

Note 21.4 When not executing a write cycle, EPP nWRITE is inactive high.

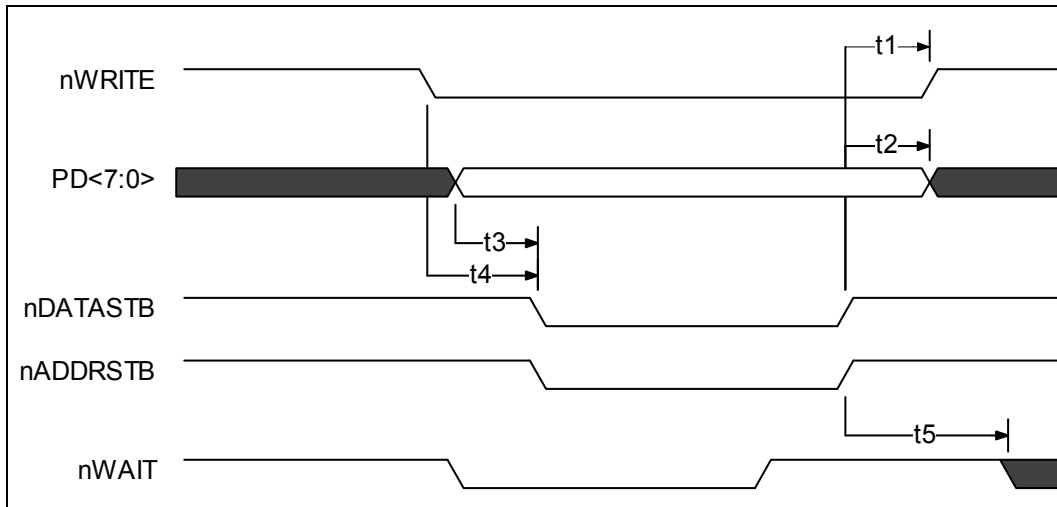

Figure 21.14 - EPP 1.7 Data or Address Write Cycle

NAME	DESCRIPTION	MIN	TYP	MAX	UNITS
t1	Command Deasserted to nWRITE Change	0		40	ns
t2	Command Deasserted to PDATA Invalid	50			ns
t3	PDATA Valid to Command Asserted	10		35	ns
t4	nWRITE to Command	5		35	ns
t5	Command Deasserted to nWAIT Deasserted	0			ns

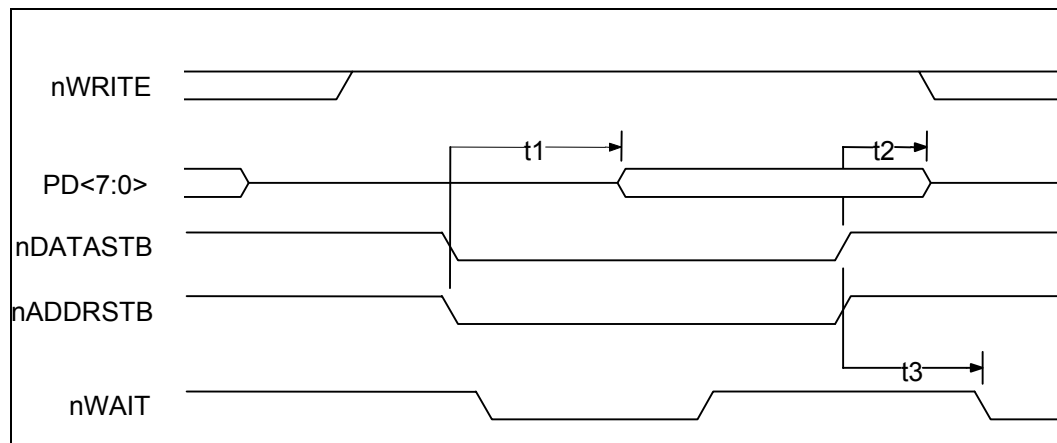

Figure 21.15 - EPP 1.7 Data or Address Read Cycle

NAME	DESCRIPTION	MIN	TYP	MAX	UNITS
t1	Command Asserted to PDATA Valid	0			ns
t2	Command Deasserted to PDATA Hi-Z	0			ns
t3	Command Deasserted to nWAIT Deasserted	0			ns

21.5 ECP Parallel Port Timing

Parallel Port FIFO (Mode 101)

The standard parallel port is run at or near the peak 500KBytes/sec allowed in the forward direction using DMA. The state machine does not examine nACK and begins the next transfer based on Busy. Refer to Figure 21.16 - Parallel Port FIFO Timing.

ECP Parallel Port Timing

The timing is designed to allow operation at approximately 2.0 Mbytes/sec over a 15ft cable. If a shorter cable is used then the bandwidth will increase.

Forward-Idle

When the host has no data to send it keeps HostClk (nStrobe) high and the peripheral will leave PeriphClk (Busy) low.

Forward Data Transfer Phase

The interface transfers data and commands from the host to the peripheral using an interlocked PeriphAck and HostClk. The peripheral may indicate its desire to send data to the host by asserting nPeriphRequest.

The Forward Data Transfer Phase may be entered from the Forward-Idle Phase. While in the Forward Phase the peripheral may asynchronously assert the nPeriphRequest (nFault) to request that the channel be reversed. When the peripheral is not busy it sets PeriphAck (Busy) low. The host then sets HostClk (nStrobe) low when it is prepared to send data. The data must be stable for the specified setup time prior to the falling edge of HostClk. The peripheral then sets PeriphAck (Busy) high to acknowledge the handshake. The host then sets HostClk (nStrobe) high. The peripheral then accepts the data and sets PeriphAck (Busy) low, completing the transfer. This sequence is shown in Figure 21.17 - ECP Parallel Port Forward Timing.

The timing is designed to provide 3 cable round-trip times for data setup if Data is driven simultaneously with HostClk (nStrobe).

Reverse-Idle Phase

The peripheral has no data to send and keeps PeriphClk high. The host is idle and keeps HostAck low.

Reverse Data Transfer Phase

The interface transfers data and commands from the peripheral to the host using an interlocked HostAck and PeriphClk.

The Reverse Data Transfer Phase may be entered from the Reverse-Idle Phase. After the previous byte has been accepted the host sets HostAck (nALF) low. The peripheral then sets PeriphClk (nACK) low when it has data to send. The data must be stable for the specified setup time prior to the falling edge of PeriphClk. When the host is ready to accept a byte it sets HostAck (nALF) high to acknowledge the handshake. The peripheral then sets PeriphClk (nACK) high. After the host has accepted the data it sets HostAck (nALF) low, completing the transfer. This sequence is shown in Figure 21.18 - ECP Parallel Port Reverse Timing.

Output Drivers

To facilitate higher performance data transfer, the use of balanced CMOS active drivers for critical signals (Data, HostAck, HostClk, PeriphAck, PeriphClk) are used in ECP Mode. Because the use of active drivers can present compatibility problems in Compatible Mode (the control signals, by tradition, are specified as

open-drain), the drivers are dynamically changed from open-drain to push-pull. The timing for the dynamic driver change is specified in then IEEE 1284 Extended Capabilities Port Protocol and ISA Interface Standard, Rev. 1.14, July 14, 1993, available from Microsoft. The dynamic driver change must be implemented properly to prevent glitching the outputs.

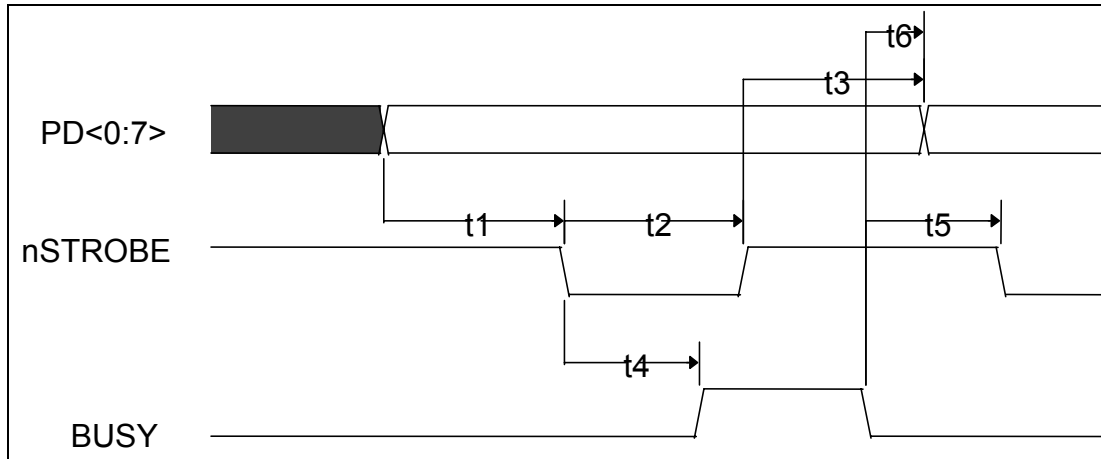
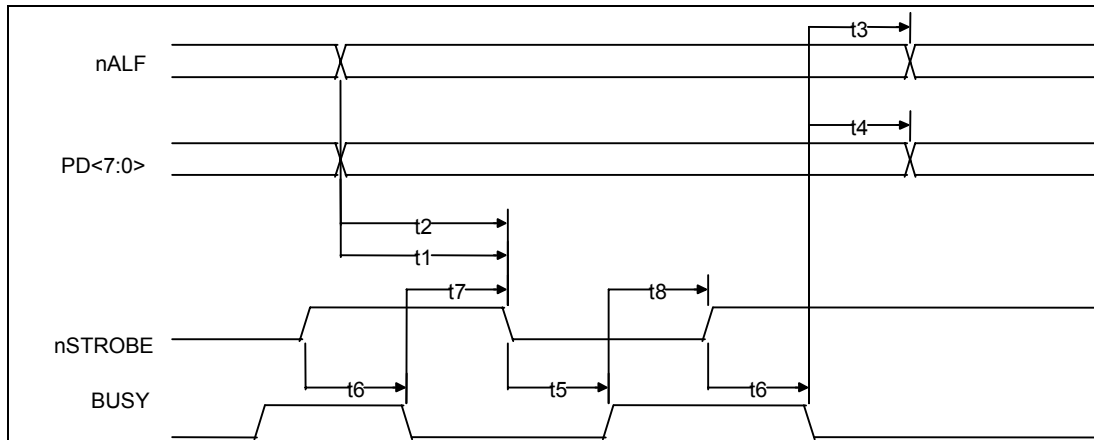

Figure 21.16 - Parallel Port FIFO Timing

NAME	DESCRIPTION	MIN	TYP	MAX	UNITS
t1	PDATA Valid to nSTROBE Active	600			ns
t2	nSTROBE Active Pulse Width	600			ns
t3	PDATA Hold from nSTROBE Inactive (Note 21.5)	450			ns
t4	nSTROBE Active to BUSY Active			500	ns
t5	BUSY Inactive to nSTROBE Active	680			ns
t6	BUSY Inactive to PDATA Invalid (Note 21.5)	80			ns

Note 21.5 The data is held until BUSY goes inactive or for time t3, whichever is longer. This only applies if another data transfer is pending. If no other data transfer is pending, the data is held indefinitely.

Figure 21.17 - ECP Parallel Port Forward Timing

NAME	DESCRIPTION	MIN	TYP	MAX	UNITS
t1	nALF Valid to nSTROBE Asserted	0		60	ns
t2	PDATA Valid to nSTROBE Asserted	0		60	ns
t3	BUSY Deasserted to nALF Changed (Note 21.6, Note 9.1)	80		180	ns
t4	BUSY Deasserted to PDATA Changed (Note 21.6, Note 9.1)	80		180	ns
t5	nSTROBE Asserted to Busy Asserted	0			ns
t6	nSTROBE Deasserted to Busy Deasserted	0			ns
t7	BUSY Deasserted to nSTROBE Asserted (Note 21.6, Note 9.1)	80		200	ns
t8	BUSY Asserted to nSTROBE Deasserted (Note 21.7)	80		180	ns

Note 21.6 Maximum value only applies if there is data in the FIFO waiting to be written out.

Note 21.7 BUSY is not considered asserted or deasserted until it is stable for a minimum of 75 to 130 ns.

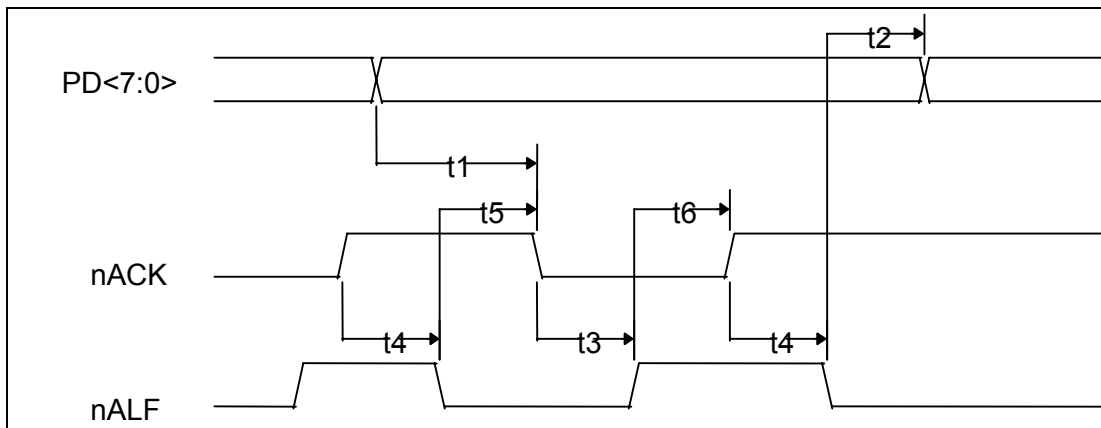

Figure 21.18 - ECP Parallel Port Reverse Timing

NAME	DESCRIPTION	MIN	TYP	MAX	UNITS
t1	PDATA Valid to nACK Asserted	0			ns
t2	nALF Deasserted to PDATA Changed	0			ns
t3	nACK Asserted to nALF Deasserted (Note 21.8, Note 21.9)	80		200	ns
t4	nACK Deasserted to nALF Asserted (Note 21.9)	80		200	ns
t5	nALF Asserted to nACK Asserted	0			ns
t6	nALF Deasserted to nACK Deasserted	0			ns

Note 21.8 Maximum value only applies if there is room in the FIFO and terminal count has not been received. ECP can stall by keeping nALF low.

Note 21.9 nACK is not considered asserted or deasserted until it is stable for a minimum of 75 to 130 ns.

21.6 IR Timing

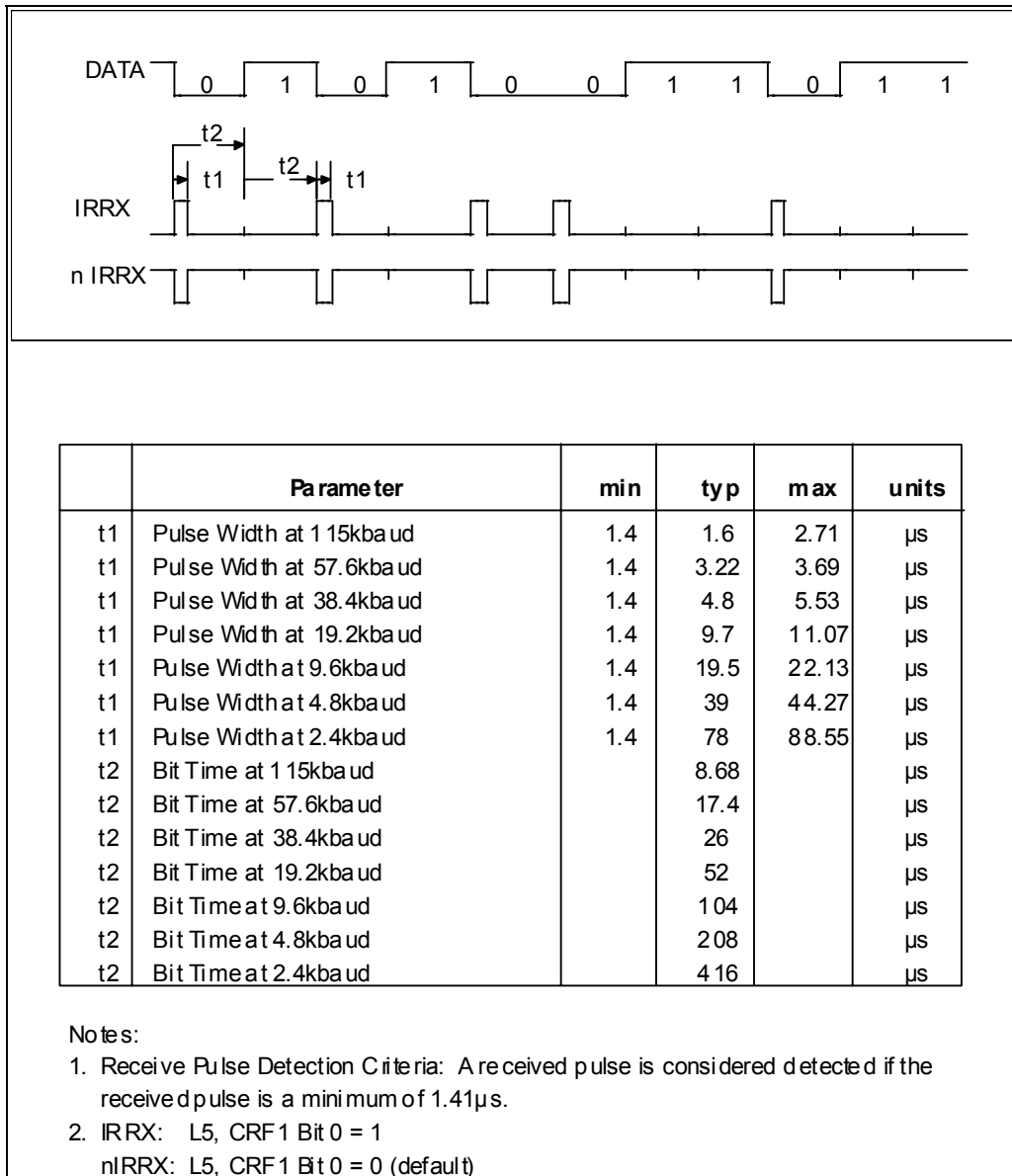

Figure 21.19 - IrDA Receive Timing

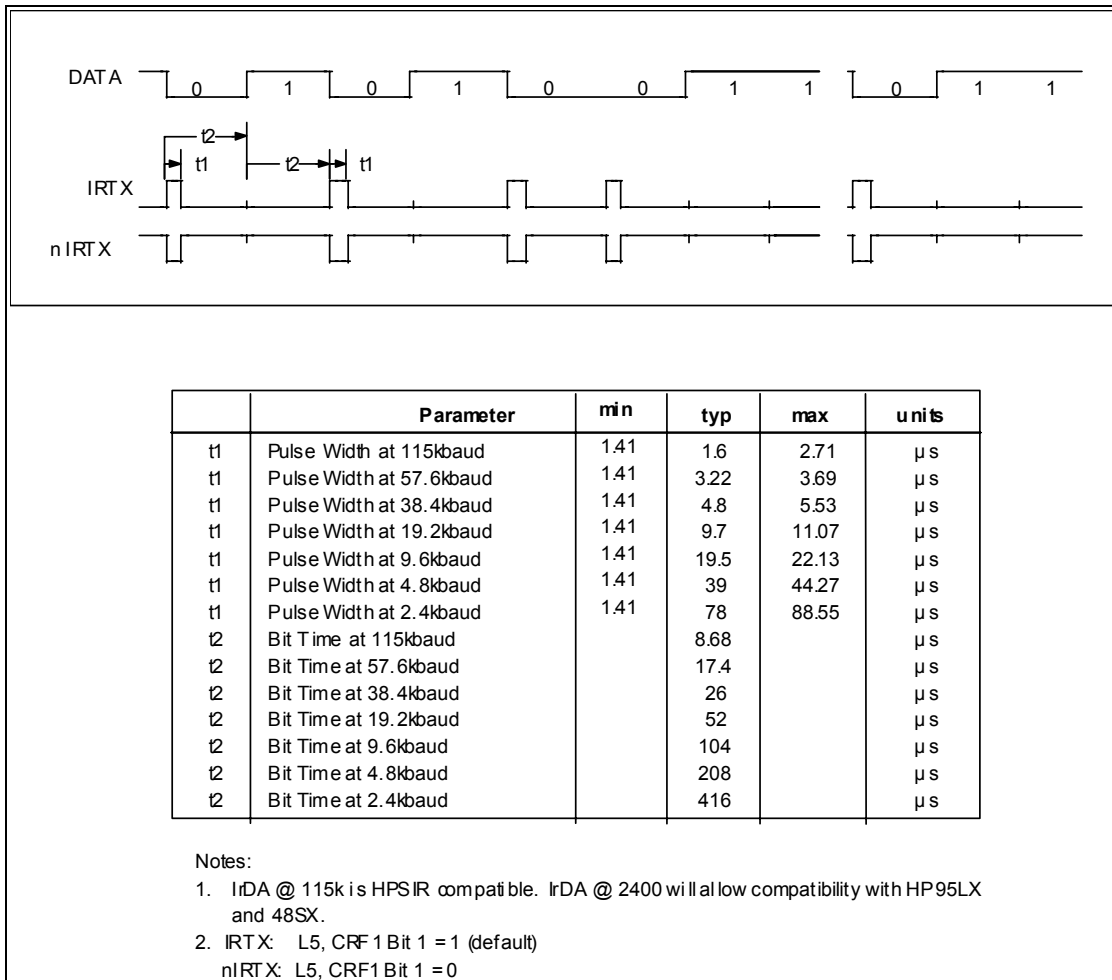
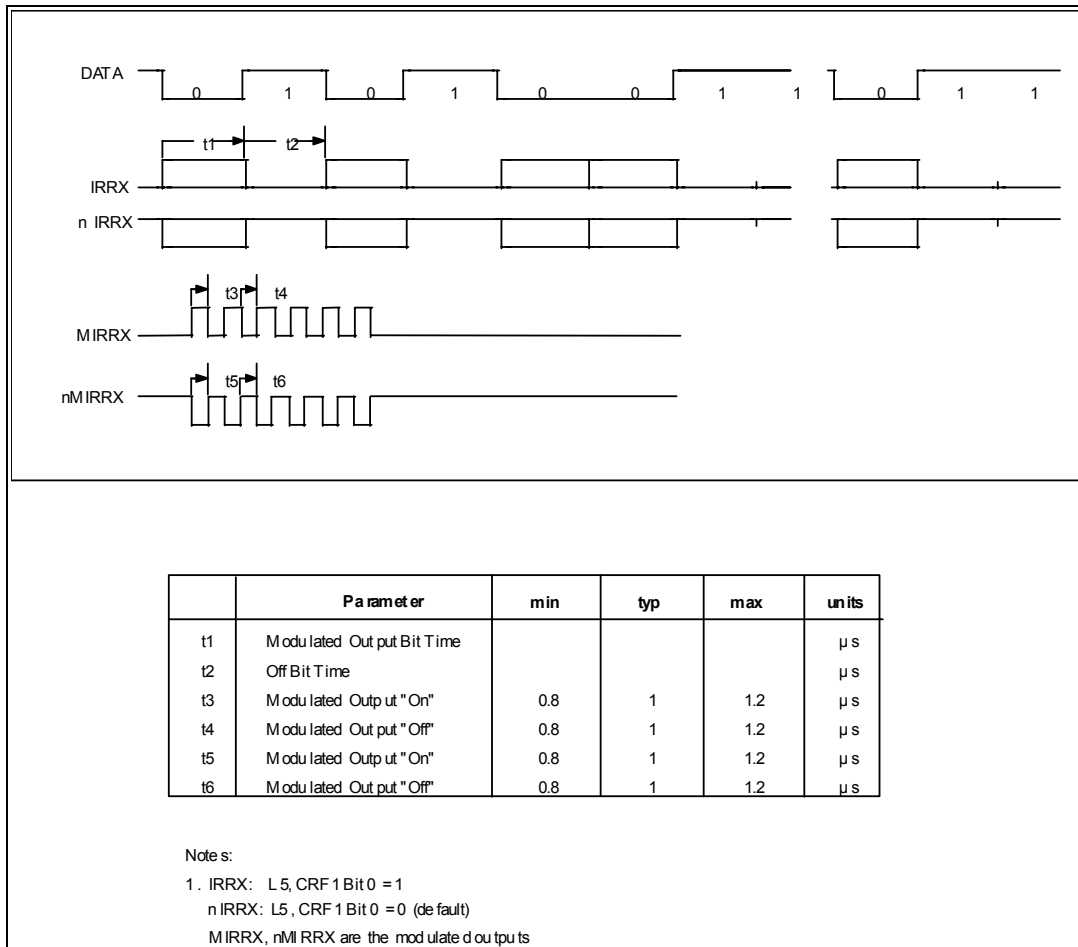

Figure 21.20 - IrDA Transmit Timing

Figure 21.21 - Amplitude Shift Keyed IR Receive Timing

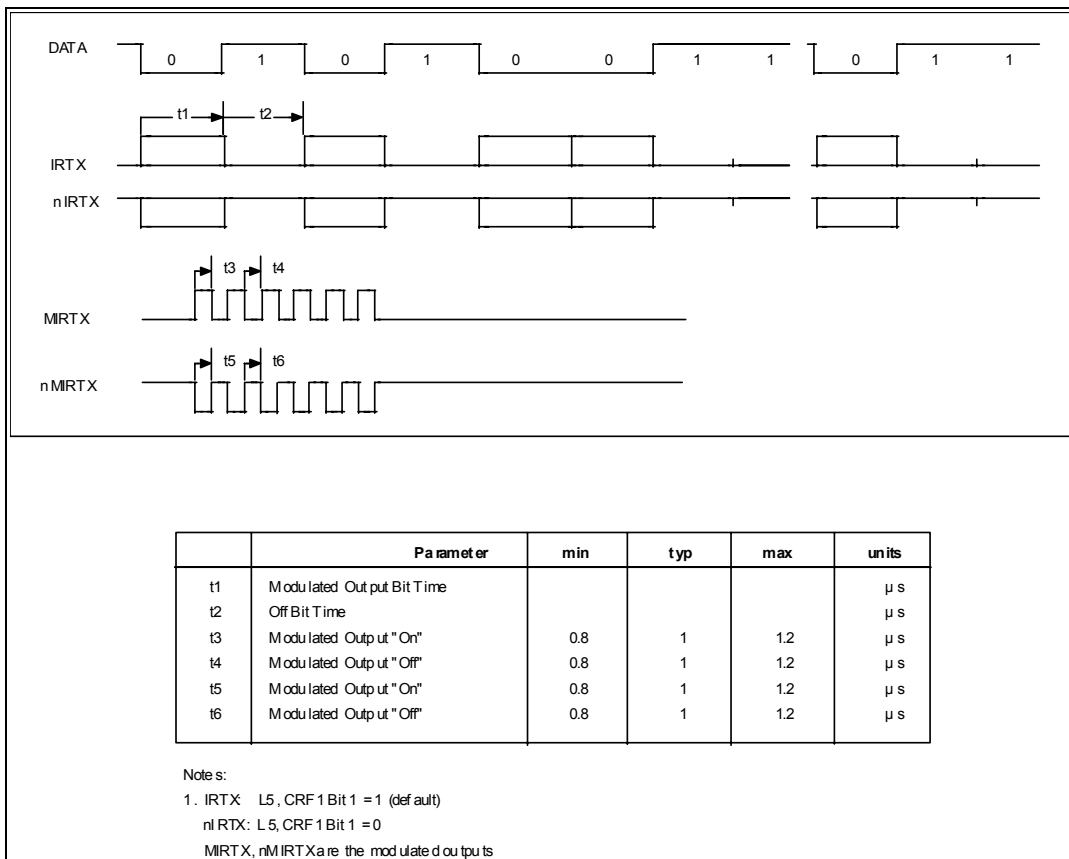

Figure 21.22 - Amplitude Shift Keyed IR Transmit Timing

21.7 Setup and Hold Timing for Serial IRQ's

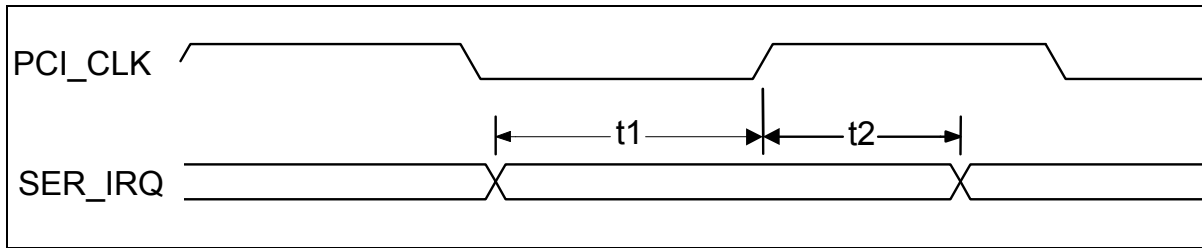

Figure 21.23 - Setup and Hold Time

NAME	DESCRIPTION	MIN	TYP	MAX	UNITS
t1	SER_IRQ Setup Time to PCI_CLK Rising	7			nsec
t2	SER_IRQ Hold Time to PCI_CLK Rising	0			nsec

21.8 UART Timing

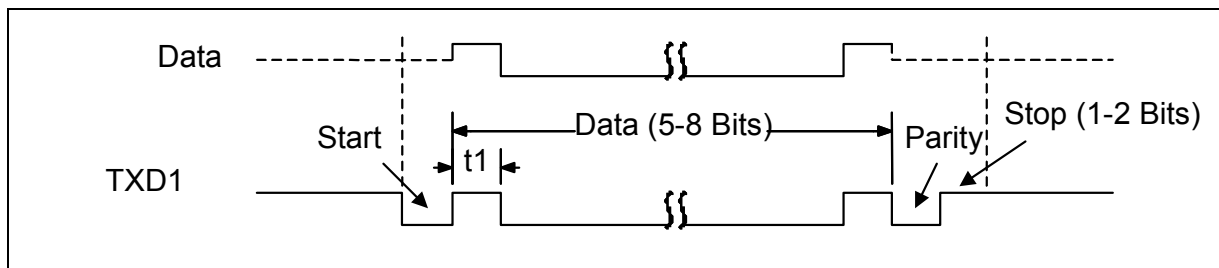

Figure 21.24 - Serial Port Data

NAME	DESCRIPTION	MIN	TYP	MAX	UNITS
t1	Serial Port Data Bit Time		t_{BR} (Note 21.10)		nsec

Note 21.10 t_{BR} is 1/Baud Rate. The Baud Rate is programmed through the divisor latch registers. Baud Rates have percentage errors indicated in the "Baud Rate" table in the "Serial Port" section.

Chapter 22 XNOR-Chain Test Mode

The LPC47N217 provides board test capability through the implementation of XNOR chain. See following sub-sections.

XNOR-Chain test structure allows users to confirm that all pins are in contact with the motherboard during assembly and test operations. See Figure 22.1 below. When the chip is in the XNOR chain test mode, setting the state of any of the input pins to the opposite of its current state will cause the output of the chain to toggle.

The XNOR-Chain test structure must be activated to perform these tests. When the XNOR-Chain is activated, the LPC47N217 pin functions are disconnected from the device pins, which all become input pins except for one output pin at the end of XNOR-Chain.

The tests that are performed when the XNOR-Chain test structure is activated require the board-level test hardware to control the device pins and observe the results at the XNOR-Chain output pin.

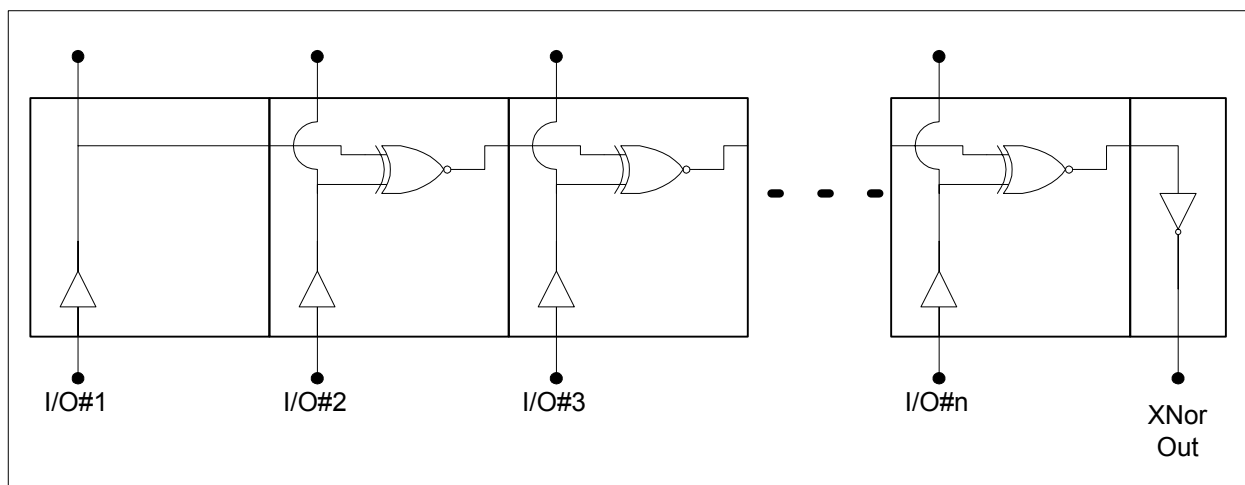

Figure 22.1 - XNOR-Chain Test Structure

22.1 Entering and Exiting Test Mode

22.1.1 XNOR-Chain test mode can be entered as follows:

On the rising (deasserting) edge of PCI_RESET#, drive LFRAME# low and drive LAD[0] low.

22.1.2 Exit XNOR-Chain test mode as follows:

On the rising (deasserting) edge of PCI_RESET#, drive either LFRAME# or LAD[0] high.

The PCI_RESET# pin is not included in the XNOR-Chain. The XNOR-Chain output pin# is 6, IO_PME#. See the following subsections for more details.

22.2 Pin List of XNOR Chain

Pins 1 to 64 on the chip are inputs to the first XNOR chain, with the exception of the following:

1. VCC (pins 11, 26, 45, and 54) and VTR (pin 7).
2. VSS (pins 8, 22, 43, and 52).
3. PCI_RESET# (pin 17).
4. IO_PME# (pin 6) This is the chain output.

To put the chip in the first XNOR chain test mode, tie LAD0 (pin 10) and LFRAME# (pin 15) low. Then toggle PCI_RESET# (pin 17) from a low to a high state. Once the chip is put into XNOR chain test mode, LAD0 (pin 10) and LFRAME# (pin 15) become part of the chain.

To exit the first XNOR chain test mode tie LAD0 (pin 10) or LFRAME# (pin 15) high. Then toggle PCI_RESET# (pin 17) from a low to a high state. A VCC POR will also cause the XNOR chain test mode to be exited. To verify the test mode has been exited, observe the output at IO_PME# (pin 6). Toggling any of the input pins in the chain should not cause its state to change.

22.3 Setup of XNOR Chain

Warning: Ensure power supply is off during setup.

1. Connect VSS (pins 8, 22, 43, and 52) to ground.
2. Connect VCC (pins 11, 26, 45, and 54) and VTR (pin 7) to VCC (3.3V).
3. Connect an oscilloscope or voltmeter to IO_PME# (pin 6).
4. All other pins should be tied to ground.

22.4 Testing Procedure

1. Turn power on.
2. With LAD0 (pin 10) and LFRAME# (pin 15), low, bring PCI_RESET# (pin 17) high. The chip is now in XNOR chain test mode. At this point, all inputs to the first XNOR chain are low. The output, on IO_PME# (pin 6), should be high. Refer to INITIAL CONFIG on TRUTH TABLE 1.
3. Bring pin 64 high. The output on IO_PME# (pin 6) should go low. Refer to STEP ONE on TRUTH TABLE 1.
4. In descending pin order, bring each input high. The output should switch states each time an input is toggled. Continue until all inputs are high. The output on IO_PME# should now be low. Refer to END CONFIG on TRUTH TABLE 1.
5. The current state of the chip is now represented by INITIAL CONFIG in TRUTH TABLE 2.
6. Each input should now be brought low, starting at pin one and continuing in ascending order. Continue until all inputs are low. The IO_PME# output should now be high. Refer to TRUTH TABLE 2.
7. To exit test mode, tie LAD0 (pin 10) OR LFRAME# (pin 15) high, and toggle PCI_RESET# from a low to a high state.

TRUTH TABLE 1 - Toggling Inputs in Descending Order

	PIN 64	PIN 63	PIN 62	PIN 61	PIN 60	PIN ...	PIN 1	OUTPUT PIN 6
INITIAL CONFIG	L	L	L	L	L	L	L	H
STEP 1	H	L	L	L	L	L	L	L
STEP 2	H	H	L	L	L	L	L	H
STEP 3	H	H	H	L	L	L	L	L
STEP 4	H	H	H	H	L	L	L	H
STEP 5	H	H	H	H	H	L	L	L
...
STEP N-1	H	H	H	H	H	H	L	H
END CONFIG	H	H	H	H	H	H	H	L

TRUTH TABLE 2 - Toggling Inputs in Ascending Order

	PIN 1	PIN 2	PIN 3	PIN 4	PIN 5	PIN ...	PIN 64	OUTPUT PIN 6
INITIAL CONFIG	H	H	H	H	H	H	H	L
STEP 1	L	H	H	H	H	H	H	H
STEP 2	L	L	H	H	H	H	H	L
STEP 3	L	L	L	H	H	H	H	H
STEP 4	L	L	L	L	H	H	H	L
STEP 5	L	L	L	L	L	H	H	H
...
STEP N-1	L	L	L	L	L	L	H	L
END CONFIG	L	L	L	L	L	L	L	H

Chapter 23 Package Outline

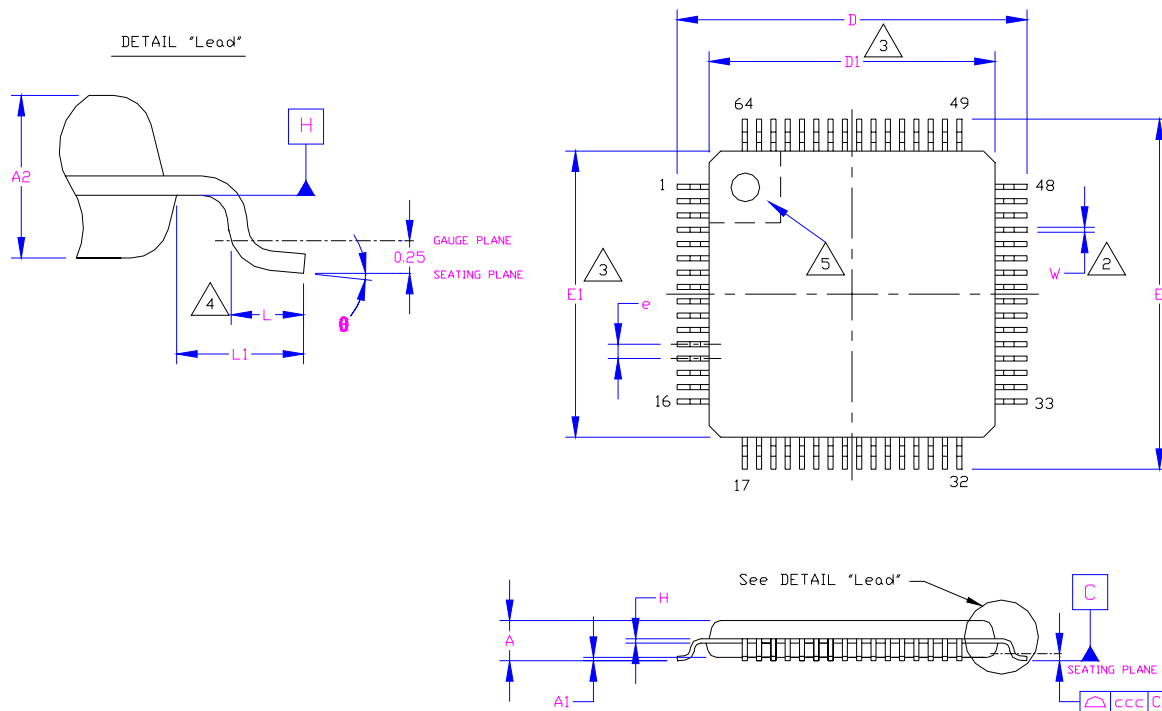

Figure 23.1 - 64 Pin STQFP Package Outline, 7X7X1.4 Body, 2 MM Footprint

Table 23.1 - 64 Pin STQFP Package Parameters

	MIN	NOMINAL	MAX	REMARKS
A	~	~	1.60	Overall Package Height
A1	0.05	~	0.15	Standoff
A2	1.35	1.40	1.45	Body Thickness
D	8.80	9.00	9.20	X Span
D1	6.80	7.00	7.20	X body Size
E	8.80	9.00	9.20	Y Span
E1	6.80	7.00	7.20	Y body Size
H	0.09	~	0.20	Lead Frame Thickness
L	0.45	0.60	0.75	Lead Foot Length
L1	~	1.00 REF.	~	Lead Length
e	0.40 Basic			Lead Pitch
θ	0°	~	7°	Lead Foot Angle
W	0.13	0.18	0.23	Lead Width
ccc	~	~	0.08	Coplanarity

Notes:

- Controlling Unit: millimeter.
- Tolerance on the true position of the leads is ± 0.035 mm maximum.
- Package body dimensions D1 and E1 do not include the mold protrusion. Maximum mold protrusion is 0.25 mm per side. D1 and E1 dimensions determined at datum plane H.
- Dimension for foot length L measured at the gauge plane 0.25 mm above the seating plane.
- Details of pin 1 identifier are optional but must be located within the zone indicated.

Mouser Electronics

Authorized Distributor

Click to View Pricing, Inventory, Delivery & Lifecycle Information:

[Microchip:](#)

[LPC47N217-JV](#)



Стандарт Электрон Связь

Мы молодая и активно развивающаяся компания в области поставок электронных компонентов. Мы поставляем электронные компоненты отечественного и импортного производства напрямую от производителей и с крупнейших складов мира.

Благодаря сотрудничеству с мировыми поставщиками мы осуществляем комплексные и плановые поставки широчайшего спектра электронных компонентов.

Собственная эффективная логистика и склад в обеспечивает надежную поставку продукции в точно указанные сроки по всей России.

Мы осуществляем техническую поддержку нашим клиентам и предпродажную проверку качества продукции. На все поставляемые продукты мы предоставляем гарантию .

Осуществляем поставки продукции под контролем ВП МО РФ на предприятия военно-промышленного комплекса России , а также работаем в рамках 275 ФЗ с открытием отдельных счетов в уполномоченном банке. Система менеджмента качества компании соответствует требованиям ГОСТ ISO 9001.

Минимальные сроки поставки, гибкие цены, неограниченный ассортимент и индивидуальный подход к клиентам являются основой для выстраивания долгосрочного и эффективного сотрудничества с предприятиями радиоэлектронной промышленности, предприятиями ВПК и научно-исследовательскими институтами России.

С нами вы становитесь еще успешнее!

Наши контакты:

Телефон: +7 812 627 14 35

Электронная почта: sales@st-electron.ru

Адрес: 198099, Санкт-Петербург,
Промышленная ул, дом № 19, литера Н,
помещение 100-Н Офис 331