

EVALUATION BOARD MANUAL

EBSGCN Series

EVALUATION KIT MANUAL

EKSGCN Series

for EYSGCN series Bluetooth[®] Smart Module

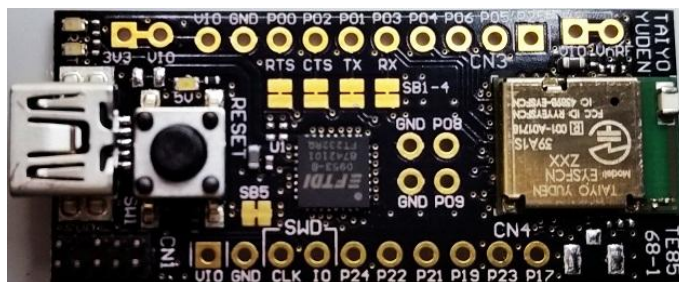

EBSGCN, EKSGCN

TAIYO YUDEN

Introduction

This evaluation board is applicable for Taiyo Yuden's **Bluetooth® 4.2 Low Energy** module, EYSGCN Series.

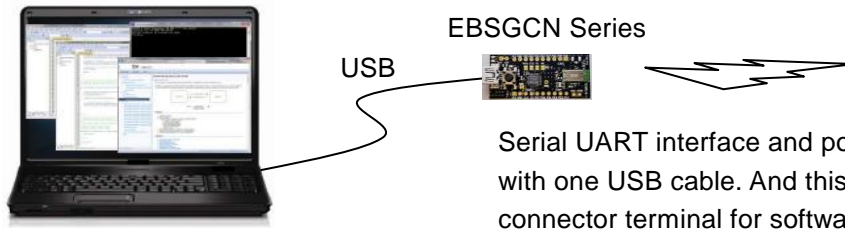

Mounted module

EYSGCN (9.6mm x 12.9mm x 2.0mm_MAX)



Nordic nRF51822 / ARM® Cortex™-M0 32 bit processor
49-pin Land Grid Array / 29GPIOs / SWD

- Basic Module -

Taiyo Yuden writes firmware for S120 (EYSGCNZWY) SoftDevice to this product.
The user can develop unique application for the module.

Content

| | | |
|---|--|-------|
| 1 | EBSGCN Series Evaluation Board (PCB name_TE8519-1) | 1 pc |
| 2 | CD-ROM (DataReport, EVBManual) | 1 set |
| 3 | J-Link Lite (EKSGCNZWY Only) | 1 set |



TAIYO YUDEN

EBSGCN, EKSGCN

TAIYO YUDEN

Evaluation board circuit schematic

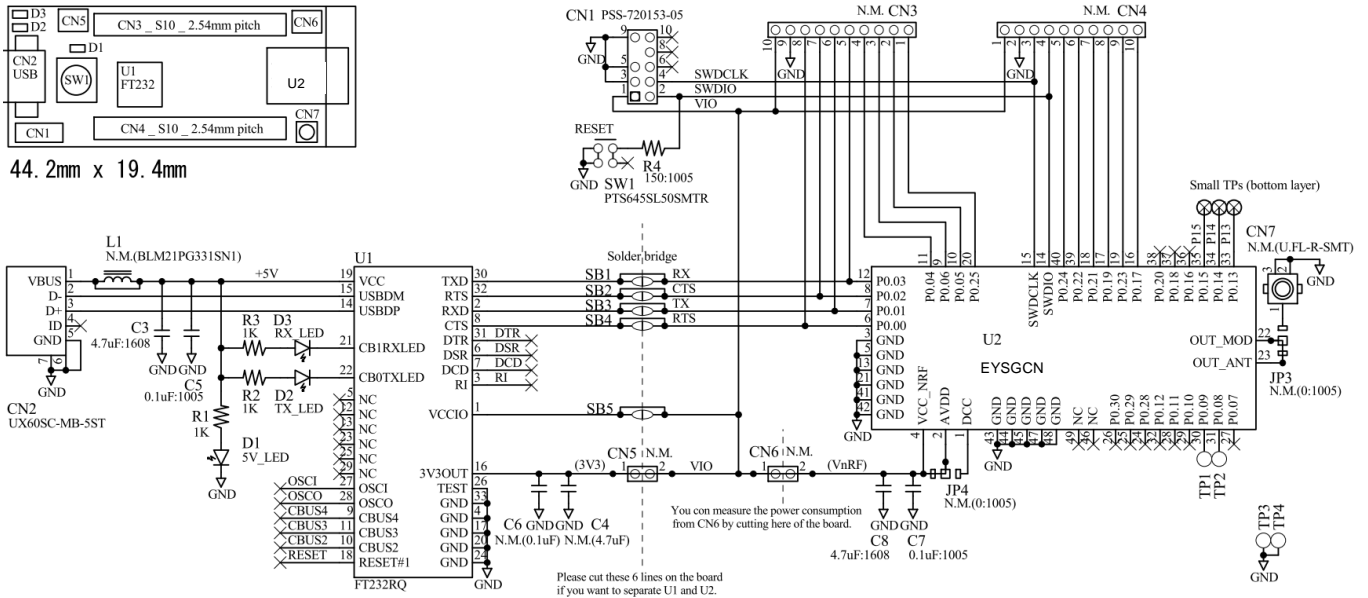

Evaluation board layout

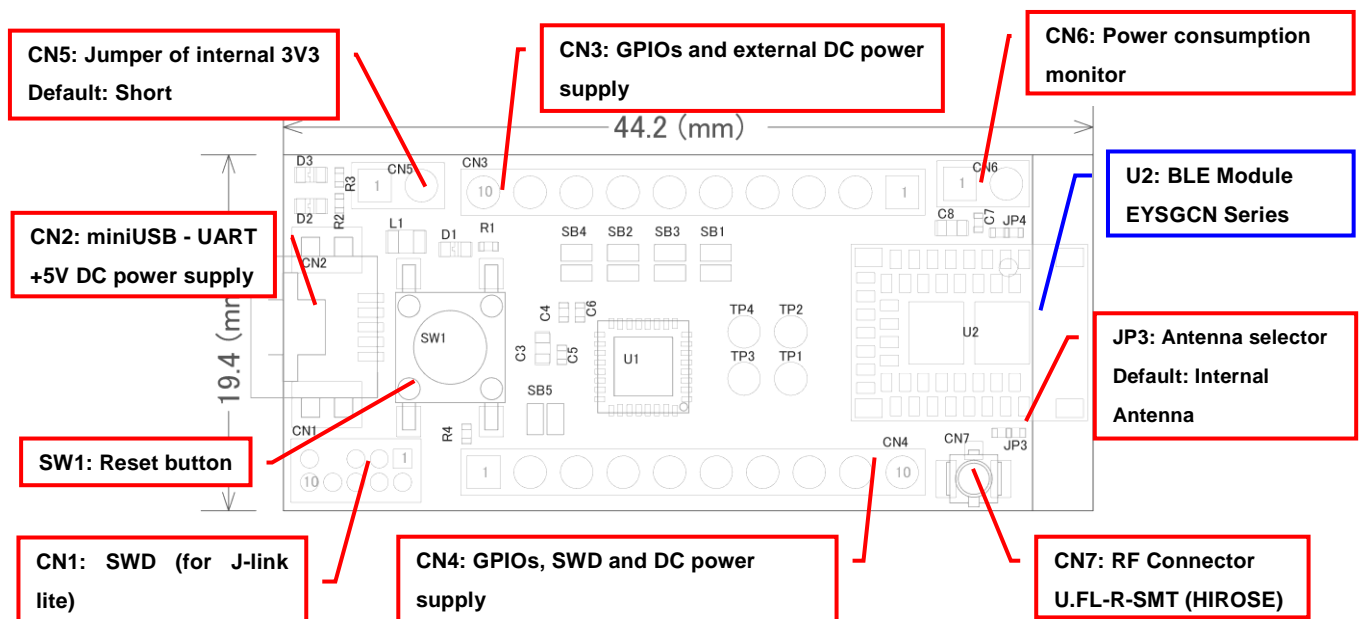

- 1) All pin headers are 2.54mm pitch. And distance between CN3 and CN4 is 15.24mm.
- 2) CN3-CN6, C4, C6, L1, JP3, JP4, SB1-5, TP1-4 are not mounted (N.M.).
- 3) D1 (LED): USB VBUS 5V LED Indicator
- 4) D2 (LED): UART TX Indicator
- 5) D3 (LED): UART RX Indicator
- 6) SW1 (Push button): Module Reset (active low)

TAIYO YUDEN

EBSGCN, EKSGCN

TAIYO YUDEN

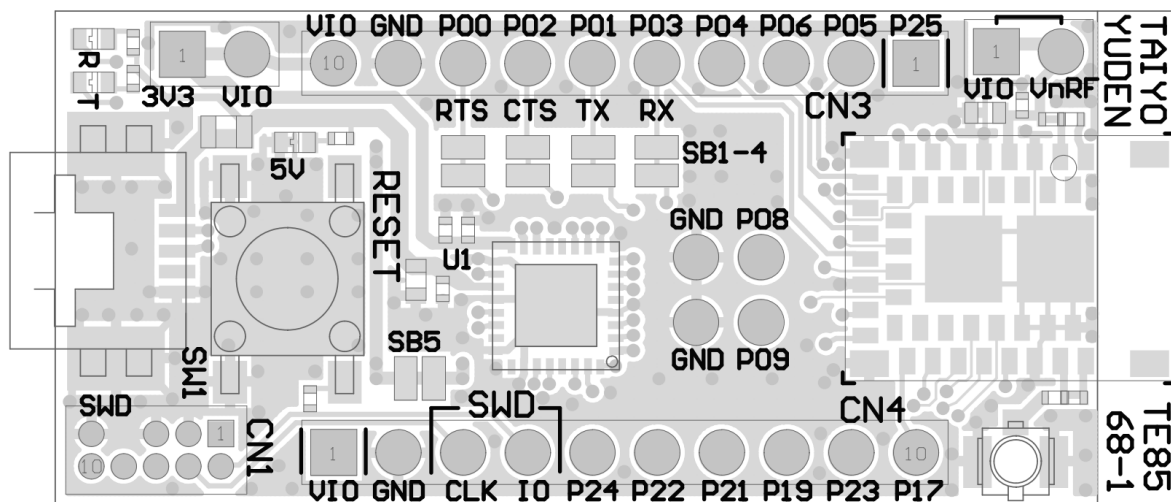
Silkscreen PrintingPin Descriptions

| Pin No. | CN3 | CN4 |
|---------|-------|--------|
| 1 | P0.25 | VIO |
| 2 | P0.05 | GND |
| 3 | P0.06 | SWDCLK |
| 4 | P0.04 | SWDIO |
| 5 | P0.03 | P0.24 |
| 6 | P0.01 | P0.22 |
| 7 | P0.02 | P0.21 |
| 8 | P0.00 | P0.19 |
| 9 | GND | P0.23 |
| 10 | VIO | P0.17 |

TAIYO YUDEN

EBSGCN, EKSGCN

TAIYO YUDEN

How to use

It is very easy just to tie this board to the PC with a USB cable. It is not necessary to change the setting of the board. The power supply of the module supplies by default 3.3V from 3V3OUT of FT232RQ.

For software development

Nordic-DK and Use case

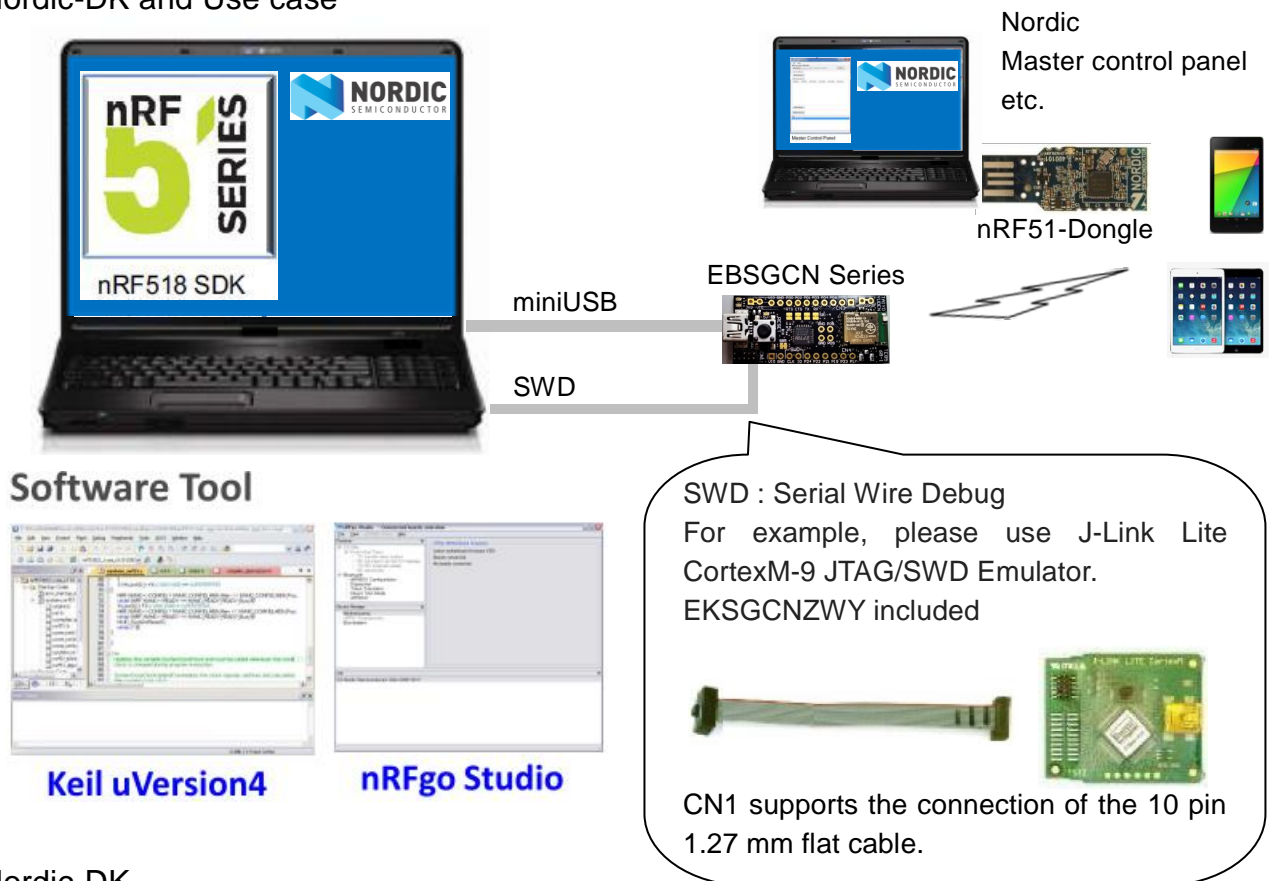

Nordic-DK

<http://www.nordicsemi.com/eng/Products/nRF51-DK>

Nordic-nRF51DK

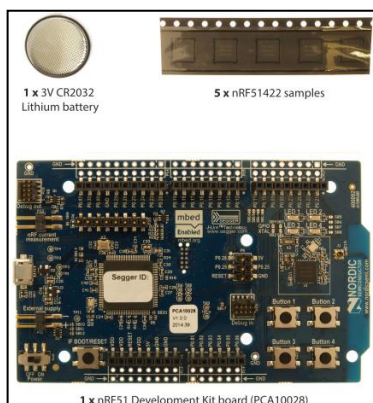

TAIYO YUDEN

MEMO

1) Current measurement

To measure the current, please cut the shorting 1pin and 2 pin of CN6. And connect an ampere-meter between the pins of connector CN6 to monitor the current directly.

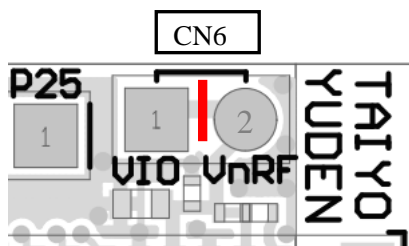

2) About the power supply of the module

When you use external power supply, please supply power from 9pin and 10pin of CN3. On this configuration, you cut short circuit 1pin and 2pin of CN5 and should separate 3V3OUT of FT232RQ.

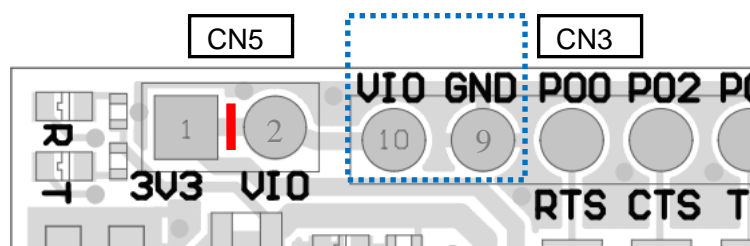

3) USB to serial UART interface

It needs to install driver of FT232RQ to use USB for UART interface. The drivers are available on FTDI website.

<http://www.ftdichip.com/Drivers/D2XX.htm>

In addition, by the application development, please assign GPIO as follows.

| GPIO | UART |
|-------|------|
| P0.00 | RTS |
| P0.01 | TX |
| P0.02 | CTS |
| P0.03 | RX |

Important notes

The evaluation board included with the Nordic Development Kit uses a 16MHz clock. Therefore the sample code from Nordic is designed to be used with a 16MHz clock. On the other hand, the EYSGCN series module uses a 32MHz system clock, making it incompatible with the Nordic sample code (i.e. sample code does not configure HFCLK: XTALFREQ register for **32MHz**). To fix this issue, we need to write the value 0xFFFFFFF00 to the UICR (User Information Configuration Register) at address 0x10001008. Please note that the UICR is erased whenever you download a SoftDevice.

The UICR can be written by using the debug tools:

```
nrfjprog.exe --snr <your_jlink_debugger_serial_number> --memwr 0x10001008 --val 0xFFFFFFF00
```

Or the following code can be added to the SystemInit function in the system_nRF51.c file, right before launching the TASK_HFCLKSTART task:

```
if (*(uint32_t *)0x10001008 == 0xFFFFFFFF)
{
    NRF_NVMC->CONFIG = NVMC_CONFIG_WEN_Wen << NVMC_CONFIG_WEN_Pos;
    while (NRF_NVMC->READY == NVMC_READY_READY_Busy){}
    *(uint32_t *)0x10001008 = 0xFFFFFFF00;
    NRF_NVMC->CONFIG = NVMC_CONFIG_WEN_Ren << NVMC_CONFIG_WEN_Pos;
    while (NRF_NVMC->READY == NVMC_READY_READY_Busy){}
    NVIC_SystemReset();
    while (true){}
}
```



TYSA-B or TYSA-B Lite Installation model

TYSA-B (Taiyo Yuden Standard Application for BLE)
BLE Embedded Software

EYSGCNA Series. (9.6mm x 12.9mm x 2.0mm_MAX)



Nordic nRF51822 / ARM® Cortex™-M0 32 bit processor

TYSA-B is installed.
Development of the application software in the module is unnecessary.

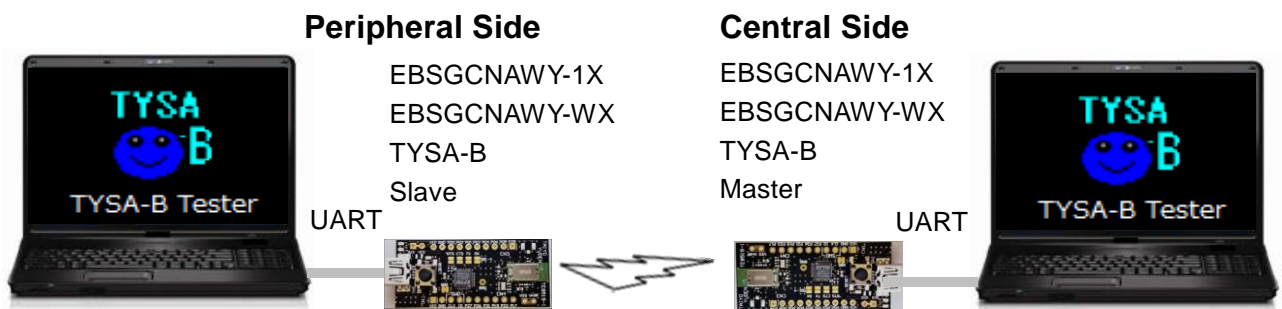

TYSA-B and TYSA-B Lite



TYSA-B





Стандарт Электрон Связь

Мы молодая и активно развивающаяся компания в области поставок электронных компонентов. Мы поставляем электронные компоненты отечественного и импортного производства напрямую от производителей и с крупнейших складов мира.

Благодаря сотрудничеству с мировыми поставщиками мы осуществляем комплексные и плановые поставки широчайшего спектра электронных компонентов.

Собственная эффективная логистика и склад в обеспечивает надежную поставку продукции в точно указанные сроки по всей России.

Мы осуществляем техническую поддержку нашим клиентам и предпродажную проверку качества продукции. На все поставляемые продукты мы предоставляем гарантию .

Осуществляем поставки продукции под контролем ВП МО РФ на предприятия военно-промышленного комплекса России , а также работаем в рамках 275 ФЗ с открытием отдельных счетов в уполномоченном банке. Система менеджмента качества компании соответствует требованиям ГОСТ ISO 9001.

Минимальные сроки поставки, гибкие цены, неограниченный ассортимент и индивидуальный подход к клиентам являются основой для выстраивания долгосрочного и эффективного сотрудничества с предприятиями радиоэлектронной промышленности, предприятиями ВПК и научно-исследовательскими институтами России.

С нами вы становитесь еще успешнее!

Наши контакты:

Телефон: +7 812 627 14 35

Электронная почта: sales@st-electron.ru

Адрес: 198099, Санкт-Петербург,
Промышленная ул, дом № 19, литера Н,
помещение 100-Н Офис 331