

Atmel ATA6612/ATA6613/ATA6614-EK Development Board V1.2

ATA6612/ATA6613/ATA6614

Features

- All necessary components to put the Atmel® ATA6612/ATA6613/ATA6614 in operation are included
- Placeholders for some optional components for extended functions included
- All pins easily accessible
- Easily adaptable watchdog times by replacing a single resistor
- Possibility to activate an external NPN-transistor for boosting up the output current of the voltage regulator (jumper JP3)
- Possibility of selecting between master or slave operation (mounting D2 and R1)
- Possibility to mount an external quartz to handle time-critical applications (not necessary for LIN communication)
- Push button included for creating a local wake-up after having entered the sleep or silent mode
- Ground coultter clip for connecting probes easily when measuring with the oscilloscope

Figure 1. Atmel ATA6612/ATA6613/ATA6614 Development Board

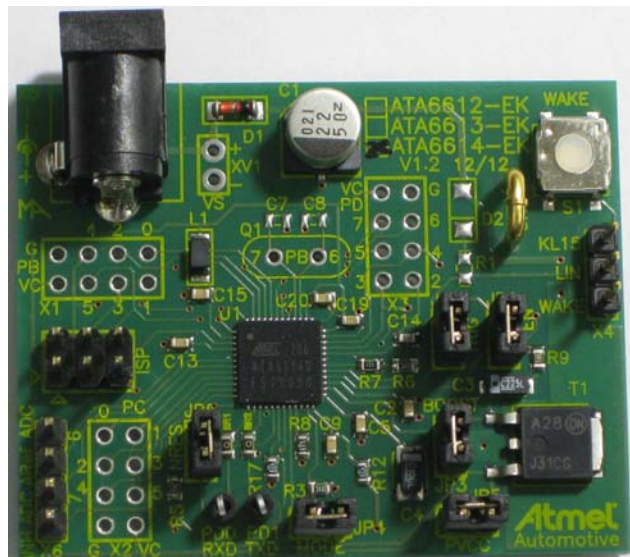

1. Introduction

The development board for the Atmel® ATA6612/ATA6613/ATA6614 ICs is designed to give designers a quick start with the respective IC and to enable prototyping and testing new LIN designs.

The Atmel ATA6612, the Atmel ATA6613 and the Atmel ATA6614 form a single-package dual-chip circuit family for LIN-bus slave and master node applications. They support highly integrated solutions for in-vehicle LIN networks. The LIN-system-basis-chip (LIN SBC) consists of a voltage regulator, a window watchdog, and a fully integrated LIN transceiver, which is in accordance with the LIN specifications 2.0, 2.1 and SAEJ2602-2. The second chip is a microcontroller from Atmel's series of AVR® 8-bit microcontrollers with advanced RISC architecture (Atmel ATmega88 in Atmel ATA6612, the Atmel ATmega168 in Atmel ATA6613 and the Atmel ATmega328P in Atmel ATA6614).

The included AVR provides the following features:

- 8/16/32Kbytes of in-system programmable flash with read-while-write capabilities
- 512/512/1024bytes EEPROM
- 1/1/2Kbyte SRAM
- 23 general purpose I/O lines
- 32 general purpose working registers
- Internal 8MHz RC oscillator calibrated at 5V at 25°C
- 3 flexible timer/counters with compare modes
- Internal and external interrupts
- Serial programmable USART suitable for LIN communication
- Byte-oriented 2-wire serial interface
- SPI serial port
- 8-channel 10-bit ADC
- Five software-selectable power-saving modes:
 - Idle mode stops the CPU while allowing the SRAM, timer/counters, USART, 2-wire serial interface, SPI port, and interrupt system to continue functioning.
 - Power-down mode saves the register contents but freezes the oscillator, disabling all other chip functions until the next interrupt or hardware reset.
 - Power-save mode: the asynchronous timer continues to run, allowing the user to maintain a timer base while the rest of the device is sleeping.
 - ADC noise reduction mode stops the CPU and all I/O modules except asynchronous timer and ADC, to minimize switching noise during ADC conversions.
 - Standby mode: the crystal/resonator oscillator is running while the rest of the device is sleeping. This allows very fast start-up combined with low power consumption.

The Atmel ATA6624, included in the Atmel ATA6612 and the Atmel ATA6613, as well as the Atmel ATA6630 included in the Atmel ATA6614, provide the following features:

- Master and slave operation possible
- Supply voltage up to 40V
- Operating voltage $V_S = 5V$ to 27V
- Typically 10 μ A supply current during sleep mode (V_{CC} switched off)
- 5V linear low-drop voltage regulator with 85mA current capability
- VCC undervoltage detection (4ms reset time) and watchdog reset logical combined at open drain output NRES
- Boosting the voltage regulator possible with an external NPN transistor
- LIN physical layer according to LIN 2.0, LIN2.1 specification and SAEJ2602-2
- Wake-up capability via LIN-bus, WAKE pin, or KI_15 pin
- INH output to control an external voltage regulator or to switch off the master pull up resistor
- TXD time-out timer
- Bus pin is overtemperature and short circuit protected versus GND and battery
- Adjustable watchdog time via external resistor

The combination of the features included in the Atmel® ATA6612, the Atmel ATA6613 and the Atmel ATA6614 make it possible to develop simple, but powerful and cheap slave nodes in LIN bus systems.

The ICs are designed to handle the low-speed data communication in vehicles, for example, in convenience electronics. Improved slope control at the LIN driver ensures secure data communication up to 20kBaud. Sleep mode and silent mode included in the LIN SBC guarantee a very low current consumption.

The Atmel ATA6612 and the Atmel ATA6613 are completely pin and functional compatible. They differ only in the size of the flash memory of the integrated microcontroller. Some minor modifications in the source code when switching between Atmel ATA6612 and Atmel ATA6613 during the development phase may be required. For more information concerning this topic, refer to the application note AVR095: "Migrating between ATmega48, ATmega88 and ATmega168" available at http://www.atmel.com/dyn/products/app_notes.asp?family_id=607.

The Atmel ATA6614 is completely pin and nearly functional compatible to the Atmel ATA6612 and the Atmel ATA6613. They differ in the used components (Microcontroller and SBC). Some minor modifications in the source code when switching between Atmel ATA6612, Atmel ATA6613 and the Atmel ATA6614 during the development phase may be required. For more information concerning this topic, refer to the application note AVR095: "Migrating between ATmega48, ATmega88 and ATmega168" available at http://www.atmel.com/dyn/products/app_notes.asp?family_id=607.

The Atmel ATA6630 has features which exceed the features of the Atmel ATA6624. Two features of the Atmel ATA6630 are not accessible in the Atmel ATA6614 due to pin-compatibility to the Atmel ATA6612 and the Atmel ATA6613. These are the integrated voltage divider and the high speed mode for the LIN communication.

Please note that the Atmel ATA6630 inside the Atmel ATA6614 signals the wake up source in a different way as the Atmel ATA6624 inside the Atmel ATA6612 and the Atmel ATA6613. Additionally the Atmel ATA6630 also signals a V_S undervoltage

As there is a standard AVR microcontroller with all pins available included in all three devices, the standard toolchain consisting of the Atmel Studio, front-end assembler and simulator, and in-circuit-emulator can be used for developing and debugging new applications. Furthermore, ActiveX components are also available that can be used to create a simple PC program for emulation of the LIN master node. Using the software components and the development board, it is very easy and inexpensive to create and test a LIN network.

In contrast to the standalone AVRs, the internal 8MHz RC oscillator has been calibrated at 5V and therefore perfectly fits the output voltage of the integrated voltage regulator.

This document has been developed to provide the user with start-up information about the development board for the Atmel ATA6612, the Atmel ATA6613 and the Atmel ATA6614. For more detailed information about the use of the devices themselves, refer to the corresponding datasheet.

2. Quick Start

The development board for the Atmel® ATA6612, Atmel ATA6613 and the Atmel ATA6614 is shipped with the default jumper settings and all accessories required for immediate use.

The IC mounted on the board is pre-programmed with a firmware in order to test and to understand the basic functions directly on the board. After correctly connecting an external 12V DC power supply between the terminals “+” and “-”, the LIN SBC is in fail-safe mode. A regulated 5V DC voltage, provided by the internal voltage regulator supplying the internal microcontroller, can be measured at the PVCC jumper. After the power is supplied to the microcontroller, the microcontroller switches the LIN SBC to normal mode by setting the EN pin to high (ENABLE jumper), and starts to trigger the integrated window watchdog. The system is now ready for data transmission via the LIN bus. Signals fed in at the TXD pin are visible on the LIN bus, and the signals at the LIN bus are visible at the RXD pin. In normal mode, the current consumption is approximately 3mA and the following voltages and signals can be seen at the corresponding pins.

Table 2-1. Overview of the Pin Status at Start-up of the Development Board

Test Point	Expected Behavior	Additional Information	Symbol
Jumper PVCC	5V DC		1
Jumper NRES	5V DC		2
Jumper EN	5V DC		3
Jumper TRIG	Frequency $f \approx 36.5\text{Hz}$	$V_{pp} = 5\text{V}$	4
TXD	Frequency $f \approx 4.33\text{kHz}$	$V_{pp} = 5\text{V}$	5
RXD	Frequency $f \approx 4.33\text{kHz}$	$V_{pp} = 5\text{V}$	6
LIN	Frequency $f \approx 4.33\text{kHz}$	$V_{pp} \cong 11\text{V}$	7
WAKE	$\sim 11.2\text{V DC}$		8
KL15	0V DC		9
INH	$\sim 11.2\text{V DC}$		10
PB0 to PB5	Frequency $f \approx 36.5\text{Hz}$	$V_{pp} = 5\text{V}$	11
PB6, PB7	Frequency $f \approx 36.5\text{Hz}$	$V_{pp} = 5\text{V}$	12
PC0 to PC5	Frequency $f \approx 36.5\text{Hz}$	$V_{pp} = 5\text{V}$	13
PD2, PD3, PD5, PD6, PD7	Frequency $f \approx 36.5\text{Hz}$	$V_{pp} = 5\text{V}$	14

Figure 2-1. Atmel ATA6612/ATA6613/ATA6614-EK Board Overview

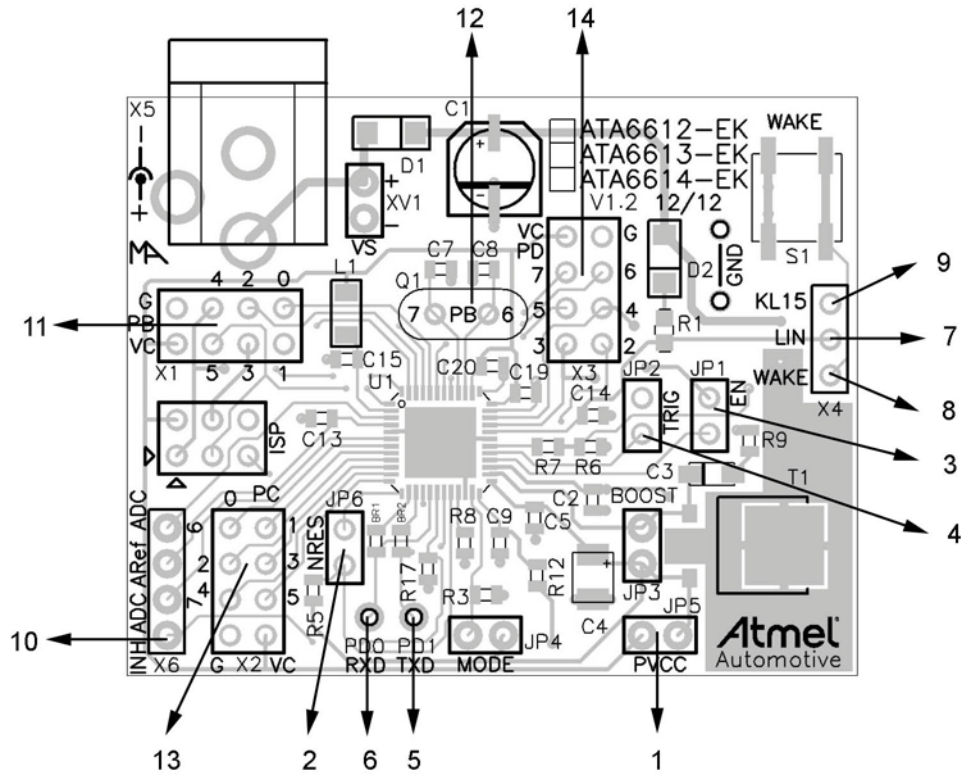

The board's pre-programmed firmware provides the window watchdog with a valid trigger signal so that the NRES pin is not forced to Ground and the microcontroller does not receive any resets.

For testing purposes and for understanding the system, it can be helpful to see the behavior when the watchdog is not triggered correctly. This can be achieved in two different ways without changing the firmware of the IC:

- Remove TRIG jumper
No trigger signal reaches the watchdog and the watchdog generates a reset directly after the lead time $t_d = 155\text{ms}$ (at $R_{WDOSC} = 51\text{k}\Omega$) has expired.
- Re-program the fuse bit
Changing the fuse bit CKDIV8 to un-programmed, changes the microcontroller's internal clock from 1MHz to 8MHz. Because of this the trigger signals generated from the microcontroller does not meet the open window from the window watchdog and a reset is generated.

3. Hardware Description

3.1 Pin Description

In the following sections the external elements required for some of the pins will be shown and described. For further information about this topic, refer to the relevant datasheet.

3.1.1 Power Supply (VB and GND)

In order to get the development board running, an external 5.7V to 18.7V DC power supply has to be connected to the power connector (positive center connector) or to the terminals “+” and “-” directly to the right of the power connector. The input circuit is protected against inverse-polarity with the protection diode D1. This causes a difference of approximately 0.7V between the supplied voltage V_{Bat} and the voltage at the VS pin.

3.1.2 Voltage Regulator (PVCC and VCC)

The internal 5V voltage regulator is capable of driving loads with up to 85mA current consumption. Therefore, the Atmel® ATA6612, the Atmel ATA6613 and the Atmel ATA6614 are able to supply the internal microcontroller, some external sensors, and/or other ICs required for the particular LIN node. The voltage regulator is protected against overloads by means of current limitation and overtemperature shutdown. To boost the maximum load current, an external NPN transistor may be used. Its base is connected to the VCC pin and its emitter is connected to PVCC. To enable this feature, the jumper PVCC, which connects the two pins PVCC and VCC by default, has to be removed.

As for the most applications 85mA will be sufficient, the jumper PVCC is set per default.

3.1.3 The Window Watchdog (NTRIG, WD_OSC and NRES)

The watchdog anticipates a trigger signal from the microcontroller at the NTRIG input (negative edge) within a defined time window. If no correct trigger signal is received during the open window, a reset signal (active low) will be generated at the NRES output. During silent mode or sleep mode the watchdog is switched off to reduce current consumption.

The timing basis of the watchdog is provided by the internal oscillator, whose time period t_{OSC} is adjustable via the external resistor R8 at the WD_OSC pin. All watchdog-specific timings (t_1 , t_2 , t_d , ...) are based on the value of this resistor. By default there is a resistor with a value of 51kΩ mounted on the development board, which results in the following timing sequence for the integrated watchdog.

Figure 3-1. Watchdog Timing Sequence with R8 = 51kΩ

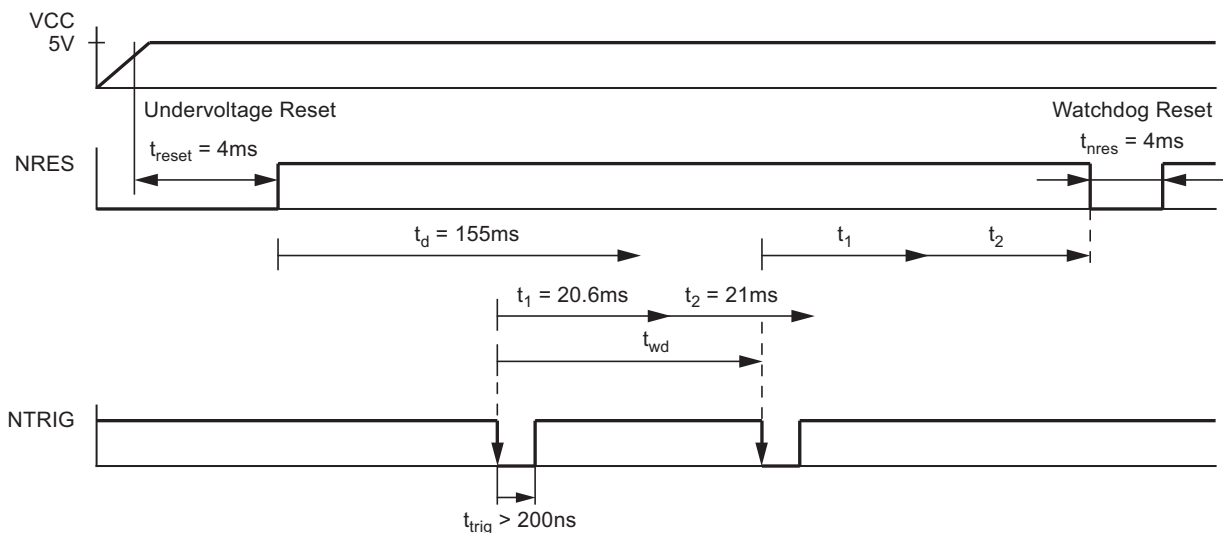

The microcontroller pin PD3 is used by default to trigger the watchdog. In order to lead the signals generated from pin PD3 to the watchdog trigger input NTRIG, the jumper TRIG has to be set. If it is not possible to use the pin PD3 to trigger the watchdog as it is being used for another function, remove the TRIG jumper completely and connect the NTRIG pin directly to another microcontroller pin using a 1-wire cable.

If the watchdog is not used, the trigger input can be left open on the development board, as it is equipped with an internal pull-up resistor. For normal use of the Atmel® ATA6612, the Atmel ATA6613 and the Atmel ATA6614 with deactivated watchdog, it is recommended that the trigger input pin NTRIG is tied directly to VCC for EMC reasons.

Replacing the resistor R8 results in a frequency change of the internal oscillator. This in turn results in different watchdog timing. The following formula demonstrates how the frequency of the internal oscillator depends on the value of the resistor R8. Refer also to the Atmel ATA6612/ATA6613/ATA6614 datasheet for further information:

$$t_{\text{OSC}} [R_{\text{WD_OSC}}] = 0.405 \times R_{\text{WD_OSC}} - 0.0004 \times (R_{\text{WD_OSC}})^2$$

t_{OSC} in μs , $R_{\text{WD_OSC}}$ in $\text{k}\Omega$

With the values given in the datasheet, you can calculate all relevant watchdog times (for example the open window and the closed window) using t_{OSC} .

In general, the Atmel ATA6612, ATA6613 and ATA6614 are shipped with an oscillator start-up time of 65ms. Due to the extra-long lead time of 155ms it should be possible in almost all cases to meet the first open window of the watchdog. If more time is needed, the default start-up time of the microcontroller 65ms can be reduced via the fuse bits to 4.1ms or even 0ms. The IC mounted on the board is delivered with a start-up time of 65ms.

3.1.4 LIN Interface (LIN, TXD and RXD)

The LIN Transceiver is only active when the LIN SBC is in the normal mode. In all other modes the transceiver is switched off and no signals from the microcontroller will be transmitted to the bus and no signals from the bus will be given to the microcontroller.

As the two pins TXD and RXD on the LIN SBC are controlled by the microcontroller's UART, they are connected to the corresponding TXD and RXD pins on the microcontroller via a zero ohm resistor. For monitoring the signals at these pins, test points are provided on the development board.

3.1.4.1 LIN Pin

A low-side driver with internal current limitation and thermal shutdown and an internal pull-up resistor in compliance with LIN spec 2.x are implemented. LIN receiver thresholds are compatible with the LIN protocol specification.

When using the development board for a LIN master application, it is possible to mount the two necessary extra components diode D2 (e.g., LL4148) in series with resistor R1 (1k Ω) on the board at their designated placeholders.

3.1.4.2 TXD Input/Output Pin (LIN SBC)

The signals given to the TXD input pin control the state of the LIN output. The TXD input pin must be pulled to Ground in order to have the LIN bus low. If TXD is high, the LIN output transistor is turned off and the bus is in recessive state, pulled up by the internal/external resistor. If TXD is low, the LIN output transistor is turned on and the bus is in dominant state. An internal timer prevents the bus line from being driven permanently in the dominant state. If TXD is forced to low longer than t_{DOM} , the LIN SBC switches the TXD state internally to high and the LIN bus driver is switched to the recessive state.

This feature is used to avoid that either a single faulty slave node or a short to Ground at the TXD pin can paralyze the communication on the complete LIN bus to which the faulty slave node is connected. Due to this behavior, the internal state of the TXD pin can differ from the signal level visible at the pin itself. However, if TXD is short-circuited to GND, it is possible to switch to sleep mode via pin EN after $t_{\text{DOM_max}}$.

3.1.4.3 TXD Input/Output Pin (Microcontroller)

The TXD-pin from the microcontroller, belonging to the hardware UART, is hard-wired to the TXD input pin from the LIN SBC via a 0 Ω resistor.

As the LIN SBC indicates the wake-up source (local wake-up or remote wake-up) with the help of the TXD pin it is recommended that the TXD pin from the microcontroller will be reconfigured as an input when entering silent mode or sleep mode. **Please note that the Atmel ATA6624 inside the Atmel ATA6612 and the Atmel ATA6613 signals the wake-up source in a different way as the Atmel ATA6630 inside the Atmel ATA6614. Additionally at the Atmel ATA6614 a V_S undervoltage is also signaled.** As long as pin EN is still low after a wake-up the LIN SBC signals the wake-up source on pin TXD.

3.1.4.4 RXD Output Pin (LIN SBC)

This pin reports the state of the LIN bus to the microcontroller. LIN high (recessive state) is reported by a high level at RXD; LIN low (dominant state) is reported by a low level at RXD. The output has an internal pull-up structure with typically 5k Ω to VCC.

This output is short-circuit protected.

The RXD pin from the microcontroller, belonging to the hardware UART, is hard-wired to the RXD input pin from the LIN SBC via a 0 Ω resistor and the current state of this pin can be monitored at a provided test point.

3.1.5 INH Pin (LIN SBC)

A 85mA current supply will be sufficient for most LIN node applications. However, if more current is needed, the INH Output can be used to switch an additional, external voltage regulator on during normal or fail-safe mode. The INH pin is automatically switched off in sleep or silent mode. In addition to switch an external voltage regulator, the INH output can also be used to switch application-specific circuit parts in order to minimize current consumption during sleep or silent mode.

3.1.6 ADC6 and ADC7 (Microcontroller)

As the ADC6 as well as the ADC7 can only be used for converting analog signals to digital values, and there is no analog output from the Atmel[®] ATA6612, the Atmel ATA6613 and the Atmel ATA6614 to measure, these two input pins have been led off the board in order to be externally connected if required.

3.1.7 WAKE (LIN SBC)

The high-voltage input pin WAKE can be used to generate a low-active local wake-up from sleep mode or silent mode. A push button is provided at this pin on the development board. If a local wake-up is not required in the application, the WAKE pin should be connected directly to V_S. In this case the two resistors R6 and R7 need to be replaced by 0 Ω resistors.

3.1.8 KL_15 (LIN SBC)

There is another option, in addition to the WAKE pin, to generate a local wake-up: the KL_15 pin. Like the WAKE pin, the KL_15 pin is also a high-voltage input, however, it is edge sensitive and gets activated on a low-to-high transition. It can be connected to the ignition of the car in order to generate a local wake-up in the application when the ignition is switched on. If this wake-up option is not used in an application this pin should be connected directly to Ground.

3.1.9 MODE Pin (LIN SBC) and Debug Mode

During the early development phase it can be helpful to deactivate the watchdog so that no resets disturb the normal application program. It is strongly recommended to use this so-called debug mode only during the development phase as the watchdog is an important safety feature for the most applications used in automotive environment.

On the development board the MODE pin is pulled to Ground via the 10k Ω resistor R3. Therefore, the watchdog is active during LIN SBC's normal mode or fail-safe mode. By setting the MODE jumper, the MODE pin is tied to 5V, and the watchdog is disabled. If the watchdog is disabled, the other reset sources (undervoltage reset and after power-up) remain active. In order to avoid all resets of the microcontroller during debugging, deactivate the watchdog by removing the NRES jumper and mounting the MODE jumper.

Please note, if the jumper NRES has been removed and an undervoltage or watchdog failure occurs, the LIN SBC switches to fail-safe mode independent of whether the microcontroller has been reset or not. In this case, the LIN transceiver is deactivated as long as the reset line is low.

3.1.10 NRES Output Pin (LIN SBC) and PC6/NRES Input Pin (Microcontroller)

The NRES output pin is an open-drain output and therefore it requires an external pull-up resistor to VCC. The PC6/NRES input pin has already a pull-up resistor included with a resistance between 30k Ω and 60k Ω . The NRES output pin of the LIN SBC is connected to the NRES input pin (PC6) of the microcontroller via the jumper "NRES". For normal operation, this jumper has to be set so that a reset signal generated from the LIN SBC will reset the microcontroller. As removing this jumper would lead to an undefined value at the NRES output pin, an additional 10k Ω resistor has been provided on the development board.

As the NRES output is an open-drain output it is not necessary to remove the jumper NRES during programming or debugging the device.

3.1.11 PB6 and PB7 (Microcontroller)

The microcontroller runs on an internal RC oscillator with a default frequency of 1MHz. As the accuracy of the internal clock is sufficient for LIN communication, in most cases there is no need for higher accuracy. However, for some applications a more accurate clock is required and therefore an external crystal oscillator can be mounted on the development board at the designated placeholder Q1 together with the required capacitors C7 and C8 (please refer also to [Section 3.4.2 “Running the Microcontroller on External Clock” on page 12](#)). Please note, that when activating the external clock, the fuse bit setting has to be changed. For more information about how to change the fuse bits and information on using an external clock, refer to the datasheet of the Atmel® ATA6612/ATA6613/ATA6614 and to the Atmel Studio documentation.

If no external clock is used, the two pins PB6 and PB7 can be used as normal I/O pins without any restriction.

3.1.12 Other Pins

All remaining pins not described in this section do not have any special external circuitry and/or they are used as described in details in the datasheet.

3.1.13 Summary of the Hard-wired Pins on the Atmel ATA6612/ATA6613/ATA6614-EK

As already described in detail in the previous sections, there are some pins tied together on the development board in hand. [Table 3-1](#) gives a summary of these pins.

Table 3-1. Summary of the Hard-wired Pins on the ATA6612/ATA6613/ATA6614-EK

Microcontroller Pin	Connected to LIN SBC Pin
PC6/NRES	NRES
PD3	NTRIG
PD4	EN
PD1	TXD
PD0	RXD

The three connections marked in **bold** are generated via jumpers and the other two connections are generated via 0Ω resistors and equipped with a test point and therefore easy to access.

3.2 Port Connectors

The Atmel ATA6612/ATA6613/ATA6614-EK has three port connectors for the microcontroller ports PortB, PortC and PortD. All non-reserved I/O pins available from the microcontroller are routed to the corresponding connectors to give the user easy access to them. All three connectors provide, besides the port pins, a voltage supply pin (5V from the internal voltage regulator) and a Ground pin in order to easily connect application-specific add-ons.

The pinouts of the three connectors are shown in [Figure 3-2](#).

Figure 3-2. Pinout of the Port Connectors

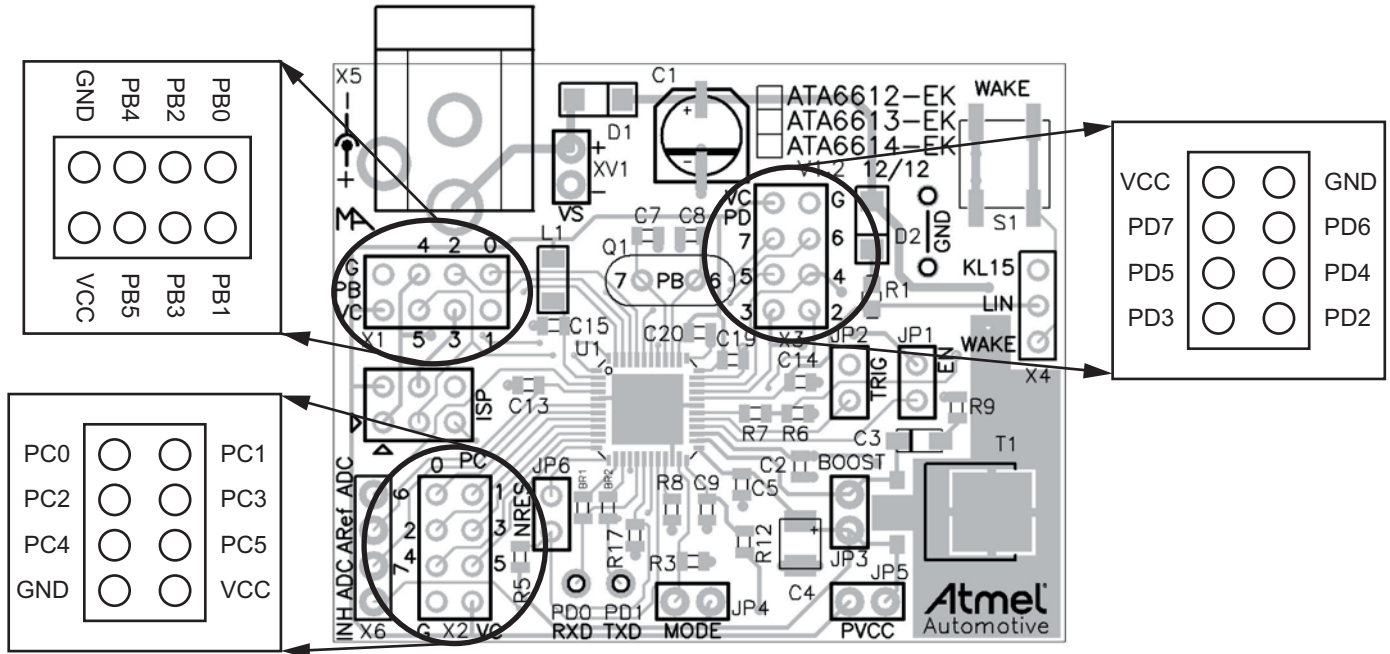

3.3 Jumper Description

In order to be more flexible and to meet as many requirements as possible, some jumpers are provided on the development board. With the help of these jumpers, users have the opportunity to engage with the system itself in order to test some features and/or to adapt the system to their requirements. In the following sections all jumpers on the development board are briefly described. For additional information, check the previous sections.

3.3.1 Jumper NRES

By default, this jumper is set to generate a connection between the NRES output of the LIN SBC and the reset input of the microcontroller. This results in a resetting of the microcontroller in the event of watchdog failures or a undervoltage at the voltage regulator output. As described earlier in this document, there may be some cases when it is helpful to remove this jumper (e.g., testing purposes, debugging). However, for normal operation of the LIN node, this jumper should be set.

3.3.2 Jumper TRIG

By default, this jumper is set to generate a connection between the watchdog trigger signal output pin PD3 from the microcontroller and the watchdog trigger signal input pin NTRIG from the LIN SBC. If pin PD3 is used for an alternative functions in the application, the TRIG jumper can be completely removed giving access to the PD3 pin. In this case, the watchdog has to be triggered by another I/O pin from the microcontroller, and the connection to the trigger input has to be made via an extra 1-wire cable.

3.3.3 Jumper MODE

By default, this jumper is removed to apply a low-level at the MODE pin of the LIN SBC via the pull-down resistor R3. In this case, the LIN SBC's watchdog is active and expects trigger pulses from the microcontroller.

For debugging an application, it is often useful to deactivate the watchdog in order to get no resets while staying at a break point for example. In this case, the MODE jumper has to be set which applies a high level at the MODE pin. From now on the watchdog is deactivated. More information about the debug mode can be found in [Section 3.1.9 "MODE Pin \(LIN SBC\) and Debug Mode"](#) on page 8.

3.3.4 Jumper PVCC

By default, this jumper is set to generate a connection between the 5V output voltage of the LIN SBC and the voltage supply pins of the microcontroller. For example, in order to determine the overall current consumption of the devices connected to the internal voltage regulator, the user can remove the jumper PVCC and interpose an ampere meter between the two now separated pins of the jumper PVCC.

This jumper has also to be removed if it is necessary to have both integrated ICs completely separate from each other (see also [Section 4.3 “Separating the Microcontroller and the LIN SBC for Debugging Purposes” on page 14](#)).

3.3.5 Jumper Boost

By default, this jumper is set so that the internal 5V voltage regulator is active with a current ability of 85mA. Most LIN nodes have this current ability or less. For LIN nodes requiring more current, the current ability can be boosted with the help of a couple of additional external components. Refer to [Section 6. “Boosting Up the Voltage Regulator” on page 15](#) for a detailed description of how to boost the current ability of the voltage regulator.

3.3.6 Jumper EN

By default, this jumper is set to generate a connection between the microcontroller enable output pin PD4 and the enable input pin EN from the LIN SBC. If pin PD4 is used for alternative functions in the application, the EN jumper can be completely removed giving access to the PD4 pin. In this case, the enable input has to be controlled either by another I/O pin from the microcontroller or it can be set fixed to VCC. In both cases, the connection to the enable input has to be made via an extra 1-wire cable.

3.4 Optional Components

The development board for the Atmel® ATA6612/ATA6613/ATA6614 provides some placeholders for mounting additional, optional components. Some already mounted components can be replaced in order to adapt the LIN node to the users specific requirements. In the following sections these placeholders and components will be shown and described.

3.4.1 Configuring the Atmel ATA6612/ATA6613/ATA6614-EK as a Master or a Slave Node

The LIN2.0 specification, as well as the LIN2.1 specification, stipulates that the master node in a LIN network has to be built up in the way depicted below.

Figure 3-3. External Circuitry for a LIN Master Node

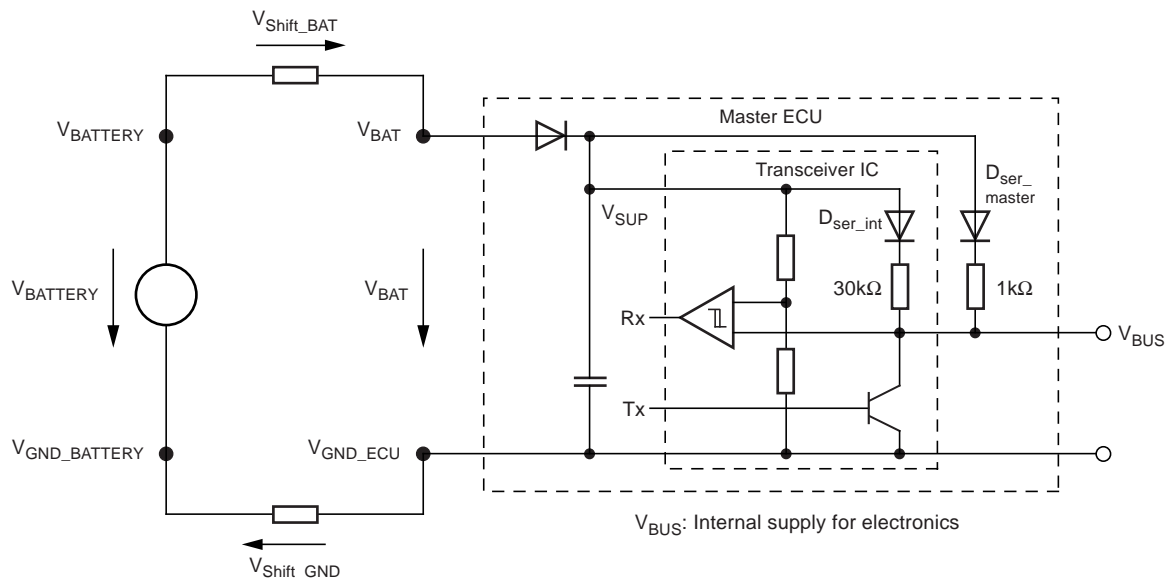

The difference regarding the hardware between a master node and a slave node is the additional diode D_{ser_master} together with a serial $1k\Omega$ resistor between V_{sup} and the LIN line. The placeholders for these two components D2 and R1 on the Atmel

ATA6612/ATA6613/ATA6614-EK are shown in [Figure 3-4](#).

Figure 3-4. Placeholders for Diode and Resistor Necessary for LIN Master Applications

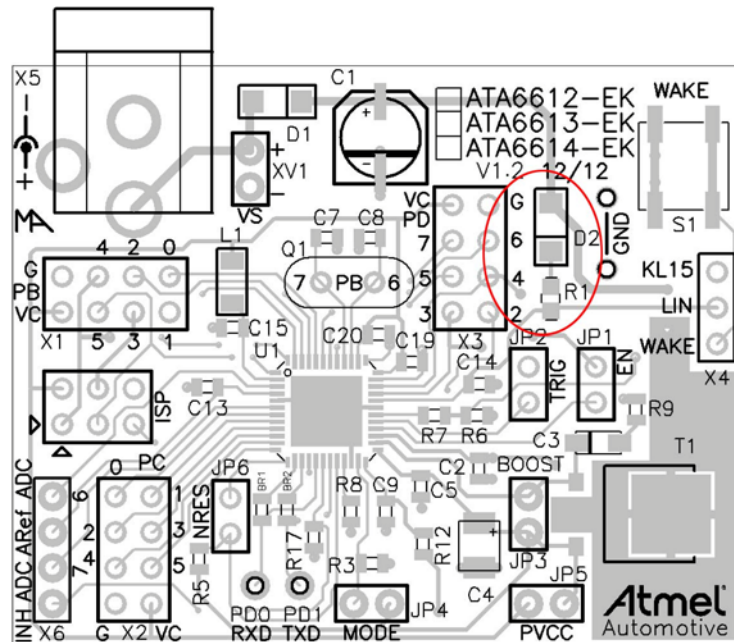

3.4.2 Running the Microcontroller on External Clock

For cases in which the accuracy of the internal RC-oscillator is not sufficient to meet the application-specific requirements, an external crystal oscillator plus the two capacitors can be mounted on the Atmel® ATA6612/ATA6613/ATA6614-EK. The location of these placeholders is shown in [Figure 3-5](#).

Figure 3-5. Placeholder for External Crystal Oscillator Plus the Corresponding Capacitors

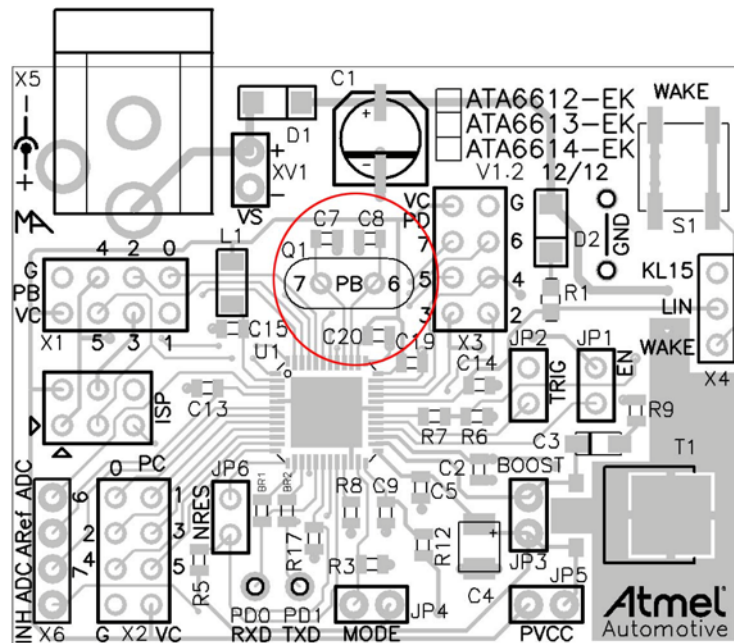

For the values of the two capacitors, check the datasheet of the desired oscillator.

3.4.3 Changing the Watchdog Timings

By default on the Atmel® ATA6612/ATA6613/ATA6614-EK, the watchdog timing is generated with the help of a 51kΩ resistor (R8) connected between pin WD_OSC and Ground. In order to change these timings, the resistor R8 has to be replaced. Its location is shown in [Figure 3-6](#).

Figure 3-6. Location of Resistor R8

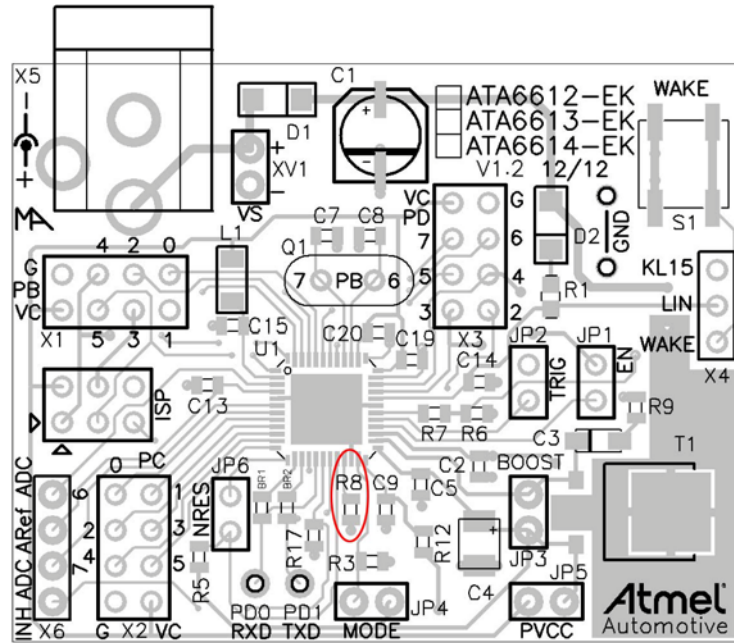

A description of how the resistor R8 influences the watchdog timing can be found in [Section 3.1.3 “The Window Watchdog \(NTRIG, WD_OSC and NRES\)”](#) on [page 6](#) and in the Atmel ATA6612/ATA6613/ATA6614 datasheet.

4. Programming and Debugging the Atmel ATA6612/ATA6613/ATA6614

The easiest way to program and to debug the Atmel® ATA6612/ATA6613/ATA6614 is to use the Atmel Studio environment together with the STK®600 or the JTAG-ICE MkII from Atmel. Atmel Studio is an integrated development platform (IDP) for writing and debugging AVR® applications in Windows® 9x/Me/NT/2000/XP/7/8 environments. Atmel Studio provides a project management tool, source file editor, chip simulator, and in-circuit emulator interface for the powerful AVR 8-bit RISC family of microcontrollers.

4.1 Programming the Atmel ATA6612/ATA6613/ATA6614

Connect the selected hardware (STK600 or JTAG-ICE MkII or another compatible tool of your choice) to the ISP header of the Atmel ATA6612/ATA6613/ATA6614-EK via the 6-wire cable. Pin “1” is marked with two little triangles on the board.

In the Atmel Studio, the three devices Atmel ATA6612, Atmel ATA6613 and the Atmel ATA6614 are not listed in the supported devices list, as they contain the standard devices Atmel ATmega88, Atmel ATmega168 and the Atmel ATmega328P respectively. So to program the Atmel ATA6612, select the Atmel ATmega88, to program the Atmel ATA6613, select the Atmel ATmega168 and to program the Atmel ATA6614 select the Atmel ATmega328P.

For further information about using the STK600, the JTAG-ICE MkII or the Atmel Studio, refer to the relevant documentation, which is available on the web.

4.2 Debugging the Atmel ATA6612/ATA6613/ATA6614

Combined with Atmel Studio, the JTAGICE MkII can perform on-chip debugging on all AVR 8-bit RISC microcontrollers with JTAG Interface or debugWIRE interface. The Atmel ATA6612, the Atmel ATA6613 and the Atmel ATA6614 come with a debugWIRE interface so only a minimum of 3 wires is required for communication between JTAGICE MkII and the board. These Signals are RESET, VCC and GND.

The debugWIRE on-chip debug system uses a one-wire bi-directional interface to control the program flow, execute AVR instructions in the CPU, and to program the different non-volatile memories. For debugging via debugWIRE, the reset line is used and the jumper NRES has to be removed as the JTAG ICE mkII needs exclusively access to this line.

For more detailed information about debugging via the debugWIRE interface, refer to the relevant documentation, which is available on the web.

4.3 Separating the Microcontroller and the LIN SBC for Debugging Purposes

For testing and/or debugging purposes sometimes it might be helpful to handle both integrated ICs completely independent from each other. In this way, it is much easier to locate the source of an occurring error.

To achieve a system with no connections between the microcontroller and the LIN SBC is easy, as there are no internal connections between both ICs. Just the following three things have to be done:

- Remove the jumper PVCC in order to remove the voltage supply to the controller.
- Remove the 0Ω resistors BR1 and BR2 in order to avoid the microcontroller to be supplied over the internal protection structure.
- Remove the jumpers NRES, NTRIG, and EN.

5. Tools

As mentioned briefly in the previous section, Atmel® Studio, in combination with the STK®600 and JTAG ICE MkII, is a powerful tool for programming and debugging the AVR® microcontroller family in general.

Furthermore, Atmel provides cost-effective software support for the development of a LIN network. These can easily be used together with the development board.

A LIN1.3 ANSI C software library for the AVR microcontroller family is available. The software library allows programming of protocol handling for LIN slave nodes. This library can be downloaded at <http://www.atmel.com/images/doc1637.pdf>

Many OEMs demand that their suppliers use certified LIN protocol stacks from a third party. To meet this requirement there are LIN2.0 as well as LIN2.1 protocol stacks available for the Atmel ATA6612 (Atmel Atmega88) as well as for the Atmel ATA6613 (Atmel Atmega168) and the Atmel ATA6614 from Mentor Graphics®, Vector Informatik, and from Warwick Control Technologies.

Warwick Control Technologies offers the NETGEN configuration and autocoder tool. For testing purposes and to provide a quick start to using Atmel's products, there is a limited but free version available. This demo version is available at <http://www.warwickcontrol.com/>

For more information about the certified LIN stacks please contact the third party suppliers directly.

6. Boosting Up the Voltage Regulator

For some applications there is a requirement for a higher current than the internal voltage regulator can deliver (85mA). In order to meet this requirement, it is possible to boost up the maximum current by using an external NPN transistor. A transistor, MJD31C in a D-PAK package, is already mounted on the development board, and in addition to the transistor there are two more components placed on the development board, the resistor R9 (3.3Ω) and the electrolytic capacitor C3 (2.2μF). In addition, the jumper boost has to be removed when using the external transistor.

Note that the output voltage is no longer short-circuit protected when boosting up the output current with an external NPN transistor.

The limiting parameter for the currently available output current is the maximum power dissipation of the external NPN transistor. In the version at this stage, the thermal resistance of the MJD31C soldered on the minimum pad size is 80K/W. This means that the possible maximum output current in the case of $V_S = 12\text{ V}$ is approximately 230mA at room temperature. It is not recommended to exceed this limit as the transistor could be damaged as a result of overtemperature. If a higher output current is required, additional cooling of the external transistor has to be ensured.

7. Appendix

7.1 Schematic and Layout of the Development Board for the Atmel ATA6612/ATA6613/ATA6614

Figure 7-1. Schematic of the Development Board for the Atmel ATA6612/ATA6613/ATA6614

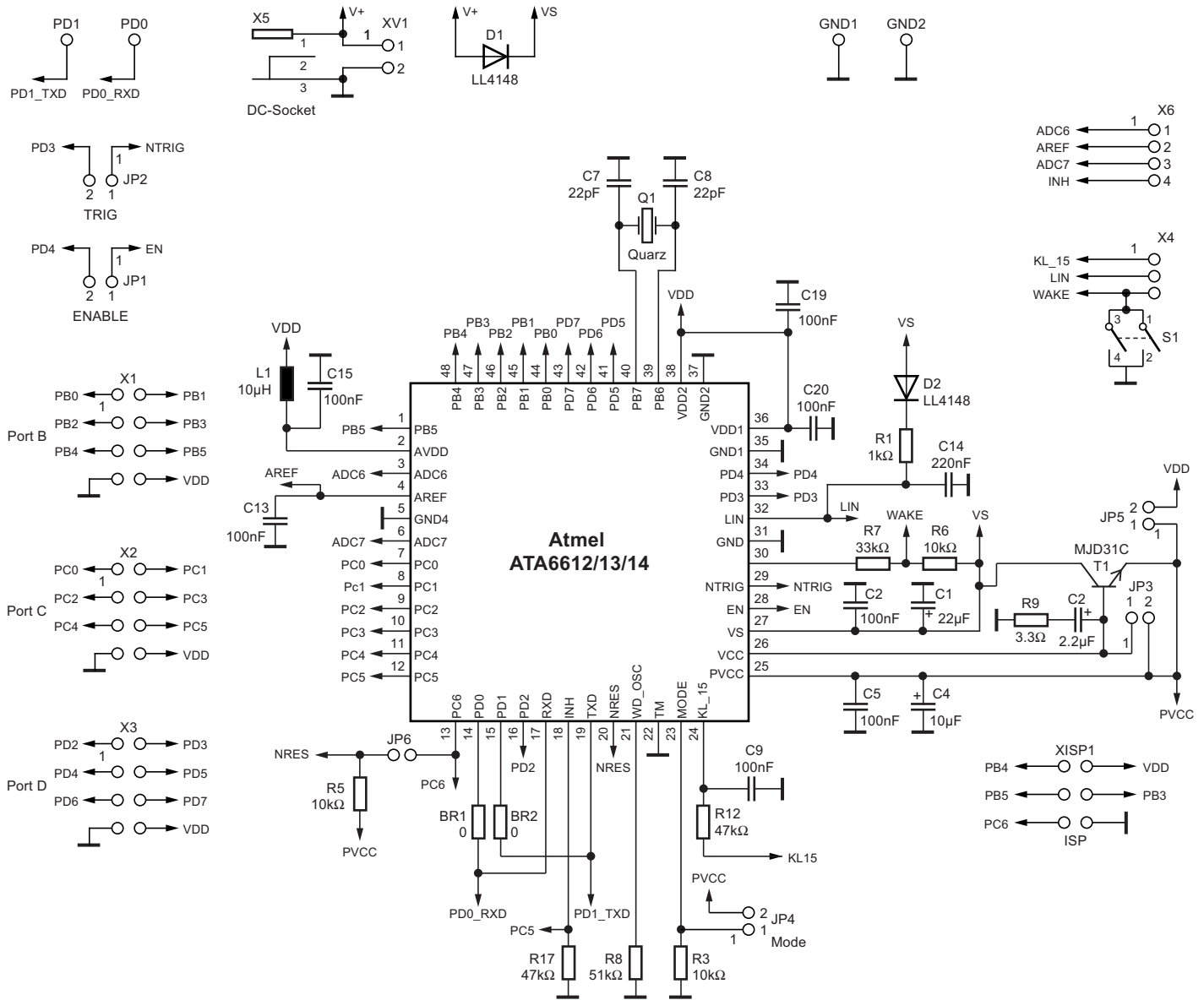
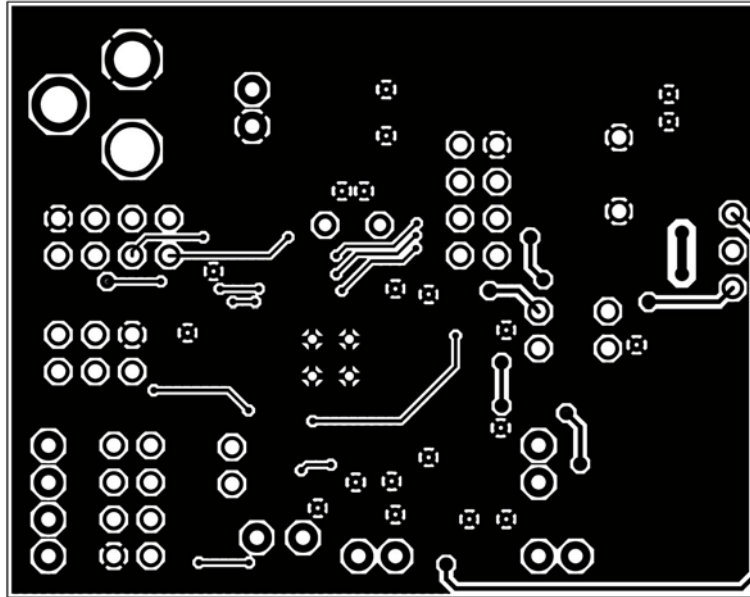

Figure 7-4. Atmel ATA6612/ATA6613/ATA6614 Development Board; Bottom Side, Top View



7.2 Further Information

7.2.1 Datasheets

1. Atmel® ATA6612/ATA6613 complete version
http://www.atmel.com/Images/Atmel-9111-LIN-Networking-ATA6612C-ATA6613C_Datasheet.pdf
2. Atmel ATA6624 complete version
http://www.atmel.com/Images/Atmel-4986-LIN-Networking-ATA6622-ATA6624-ATA6626_Datasheet.pdf
3. Atmel ATmega48/88/168 Automotive
<http://www.atmel.com/Images/doc7530.pdf>
4. Atmel ATmega88 Automotive - 150°C Specification - Appendix A Preliminary
http://www.atmel.com/dyn/resources/prod_documents/doc7607.pdf
5. Atmel ATA6614 complete version
http://www.atmel.com/Images/Atmel-9240-LIN-Networking-ATA6614Q_Datasheet.pdf
6. Atmel ATA6630 complete version
<http://www.atmel.com/Images/doc9117.pdf>
7. Atmel ATmega328P Automotive
<http://www.atmel.com/Images/doc7810.pdf>

7.2.2 Application Notes

1. AVR140: ATmega48/88/168 family run-time calibration of the Internal RC oscillator
http://www.atmel.com/dyn/resources/prod_documents/doc7653.pdf
AVR140: ATmega48/88/168 family run-time calibration of the Internal RC oscillator
This application note describes how to calibrate the internal RC oscillator via the UART. The method used is based on the calibration method used in the Local Interconnect Network (LIN) protocol - synchronizing a slave node to a master node at the beginning of every message frame.
2. AVR095: Migrating between ATmega48, ATmega88 and ATmega168
http://www.atmel.com/dyn/resources/prod_documents/doc2554.pdf
This application note describes issues to be aware of when migrating between the ATmega48, ATmega88, and ATmega168 microcontrollers.
3. AVR308: Software LIN Slave
http://www.atmel.com/dyn/resources/prod_documents/doc1637.pdf
This Application Note shows how to implement a LIN (Local Interconnect Network) slave task in an 8-bit RISC AVR® microcontroller without the need for any external components.
4. AVR322: LIN Protocol Implementation on Atmel® AVR Microcontrollers
http://www.atmel.com/dyn/resources/prod_documents/doc7548.pdf
The LIN protocol is introduced in this application note, along with its implementation on Atmel Automotive AVR microcontrollers.

8. Revision History

Please note that the following page numbers referred to in this section refer to the specific revision mentioned, not to this document.

Revision No.	History
9127E-AUTO-03/15	• Put document in the latest template



Atmel Corporation 1600 Technology Drive, San Jose, CA 95110 USA T: (+1)(408) 441.0311 F: (+1)(408) 436.4200 | www.atmel.com

© 2015 Atmel Corporation. / Rev.: 9127E-AUTO-03/15

Atmel®, Atmel logo and combinations thereof, Enabling Unlimited Possibilities®, AVR®, STK®, and others are registered trademarks or trademarks of Atmel Corporation in U.S. and other countries. Other terms and product names may be trademarks of others.

DISCLAIMER: The information in this document is provided in connection with Atmel products. No license, express or implied, by estoppel or otherwise, to any intellectual property right is granted by this document or in connection with the sale of Atmel products. EXCEPT AS SET FORTH IN THE ATMEL TERMS AND CONDITIONS OF SALES LOCATED ON THE ATMEL WEBSITE, ATMEL ASSUMES NO LIABILITY WHATSOEVER AND DISCLAIMS ANY EXPRESS, IMPLIED OR STATUTORY WARRANTY RELATING TO ITS PRODUCTS INCLUDING, BUT NOT LIMITED TO, THE IMPLIED WARRANTY OF MERCHANTABILITY, FITNESS FOR A PARTICULAR PURPOSE, OR NON-INFRINGEMENT. IN NO EVENT SHALL ATMEL BE LIABLE FOR ANY DIRECT, INDIRECT, CONSEQUENTIAL, PUNITIVE, SPECIAL OR INCIDENTAL DAMAGES (INCLUDING, WITHOUT LIMITATION, DAMAGES FOR LOSS AND PROFITS, BUSINESS INTERRUPTION, OR LOSS OF INFORMATION) ARISING OUT OF THE USE OR INABILITY TO USE THIS DOCUMENT, EVEN IF ATMEL HAS BEEN ADVISED OF THE POSSIBILITY OF SUCH DAMAGES. Atmel makes no representations or warranties with respect to the accuracy or completeness of the contents of this document and reserves the right to make changes to specifications and products descriptions at any time without notice. Atmel does not make any commitment to update the information contained herein. Unless specifically provided otherwise, Atmel products are not suitable for, and shall not be used in, automotive applications. Atmel products are not intended, authorized, or warranted for use as components in applications intended to support or sustain life.

SAFETY-CRITICAL, MILITARY, AND AUTOMOTIVE APPLICATIONS DISCLAIMER: Atmel products are not designed for and will not be used in connection with any applications where the failure of such products would reasonably be expected to result in significant personal injury or death ("Safety-Critical Applications") without an Atmel officer's specific written consent. Safety-Critical Applications include, without limitation, life support devices and systems, equipment or systems for the operation of nuclear facilities and weapons systems. Atmel products are not designed nor intended for use in military or aerospace applications or environments unless specifically designated by Atmel as military-grade. Atmel products are not designed nor intended for use in automotive applications unless specifically designated by Atmel as automotive-grade.

Mouser Electronics

Authorized Distributor

Click to View Pricing, Inventory, Delivery & Lifecycle Information:

[Microchip:](#)

[ATA6613-EK](#) [ATA6614-EK](#)



Стандарт Электрон Связь

Мы молодая и активно развивающаяся компания в области поставок электронных компонентов. Мы поставляем электронные компоненты отечественного и импортного производства напрямую от производителей и с крупнейших складов мира.

Благодаря сотрудничеству с мировыми поставщиками мы осуществляем комплексные и плановые поставки широчайшего спектра электронных компонентов.

Собственная эффективная логистика и склад в обеспечивает надежную поставку продукции в точно указанные сроки по всей России.

Мы осуществляем техническую поддержку нашим клиентам и предпродажную проверку качества продукции. На все поставляемые продукты мы предоставляем гарантию .

Осуществляем поставки продукции под контролем ВП МО РФ на предприятия военно-промышленного комплекса России , а также работаем в рамках 275 ФЗ с открытием отдельных счетов в уполномоченном банке. Система менеджмента качества компании соответствует требованиям ГОСТ ISO 9001.

Минимальные сроки поставки, гибкие цены, неограниченный ассортимент и индивидуальный подход к клиентам являются основой для выстраивания долгосрочного и эффективного сотрудничества с предприятиями радиоэлектронной промышленности, предприятиями ВПК и научно-исследовательскими институтами России.

С нами вы становитесь еще успешнее!

Наши контакты:

Телефон: +7 812 627 14 35

Электронная почта: sales@st-electron.ru

Адрес: 198099, Санкт-Петербург,
Промышленная ул, дом № 19, литера Н,
помещение 100-Н Офис 331