



---

---

## Processor Extension Pak and Header Specification

---

---

### NOTICE TO CUSTOMERS

All documentation becomes dated, and this manual is no exception. Microchip tools and documentation are constantly evolving to meet customer needs, so some actual dialogs and/or tool descriptions may differ from those in this document. Please refer to our web site ([www.microchip.com](http://www.microchip.com)) to obtain the latest documentation available.

Documents are identified with a “DS” number. This number is located on the bottom of each page, in front of the page number. The numbering convention for the DS number is “DSXXXXA”, where “XXXX” is the document number and “A” is the revision level of the document.

For the most up-to-date information on development tools, see the MPLAB® IDE or MPLAB X IDE online Help (Help menu).

This chapter contains the following:

- Processor Extension Pak and Header Defined
- Why Do I Need A Header To Debug?
- Debug Details
- Programming Details
- General Header Setup
- Device vs. Optional Header Features
- MPLAB IDE and MPLAB X IDE Use with Headers
- Calibration Bits
- Performance Issues
- Related Debug Tools
- Customer Support

### PROCESSOR EXTENSION PAK AND HEADER DEFINED

A header (or debug header) is a circuit board that allows an emulator or debugger to debug code for a specific device. A special version of the device with on-board debug circuitry is located on the header. Connectors on the side of the header allow it to connect directly or through an adaptor to the debug tool. Connectors on the bottom of the header allow it to connect directly, or through a transition socket, to a target board.

A processor extension pak contains a header, adaptor board, and stand-offs.

# Processor Extension Pak and Header Specification

## WHY DO I NEED A HEADER TO DEBUG?

Some PIC<sup>®</sup> microcontrollers, particularly low pin count devices (with 20 pins or less), generally must use a header for debugging. This is done to free up I/O lines for your application and to make production parts more affordable. Optional headers are also available for high pin count devices (with 64 pins or higher).

Debugging requires a two-line connection (plus V<sub>DD</sub>, V<sub>SS</sub> and V<sub>PP</sub>) to communicate with the device. In a high pin count device, losing a few I/O lines is generally not a problem for most designs. But in a low pin count device, it can be a critical problem. Imagine having to do an 8-pin design where there are only 5 I/Os, having used up 2 I/Os just for debugging!

Headers are also used to save you money. In high pin count devices, adding debugging to the silicon can generally be done at little or no cost since the silicon is already fairly large. However, low pin count devices are low cost specifically because they use very little silicon. So, adding debugging circuitry on-board these parts would add significant cost since it would raise the amount of silicon used by a considerable percentage. The header places the cost for debugging up front and frees your production parts from the extra cost of an unused debug module.

Microchip also makes optional debug modules, usually for high pin count devices. The module is optional because you can still do basic debugging without a header, but if you use one, you get back I/O lines, and may also gain additional debugging features. Only certain devices can use an optional header, see the device page on our website for details.

Microchip lists what header must be ordered to work with your device, if one is required. Simply consult the device page on our website, or our other ordering guides.

Note that in all cases, devices can be programmed “in circuit” (called ICSP<sup>™</sup>) with very few exceptions. Even devices without an internal debug feature can still be programmed by connecting the programming/debugging tool to the in-circuit programming lines. These devices simply cannot perform debugging without a header.

**FIGURE 1: PRODUCTION DEVICE VS. HEADER DEVICE (-ICE/ICD)**

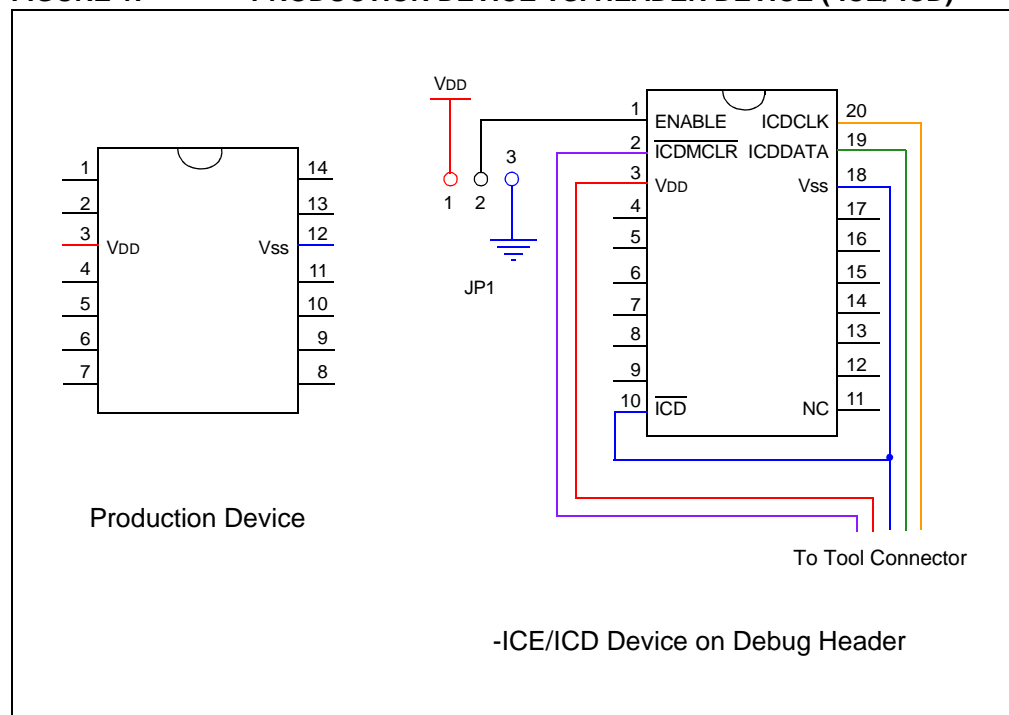

## DEBUG DETAILS

Next generation in-circuit emulators (such as the MPLAB® REAL ICE™ In-Circuit Emulator) and in-circuit debuggers work with devices that have on-chip debug circuitry. Sometimes the actual production device will have this circuitry and sometimes a special version of this device is required or available for code debugging. This special version of the chip, with the suffix -ICD or -ICE, is mounted on a debug header (Figure 2).

**Note:** ICE/ICD devices are only used on the header; they are not sold separately.

**FIGURE 2: DEBUG OPTIONS**

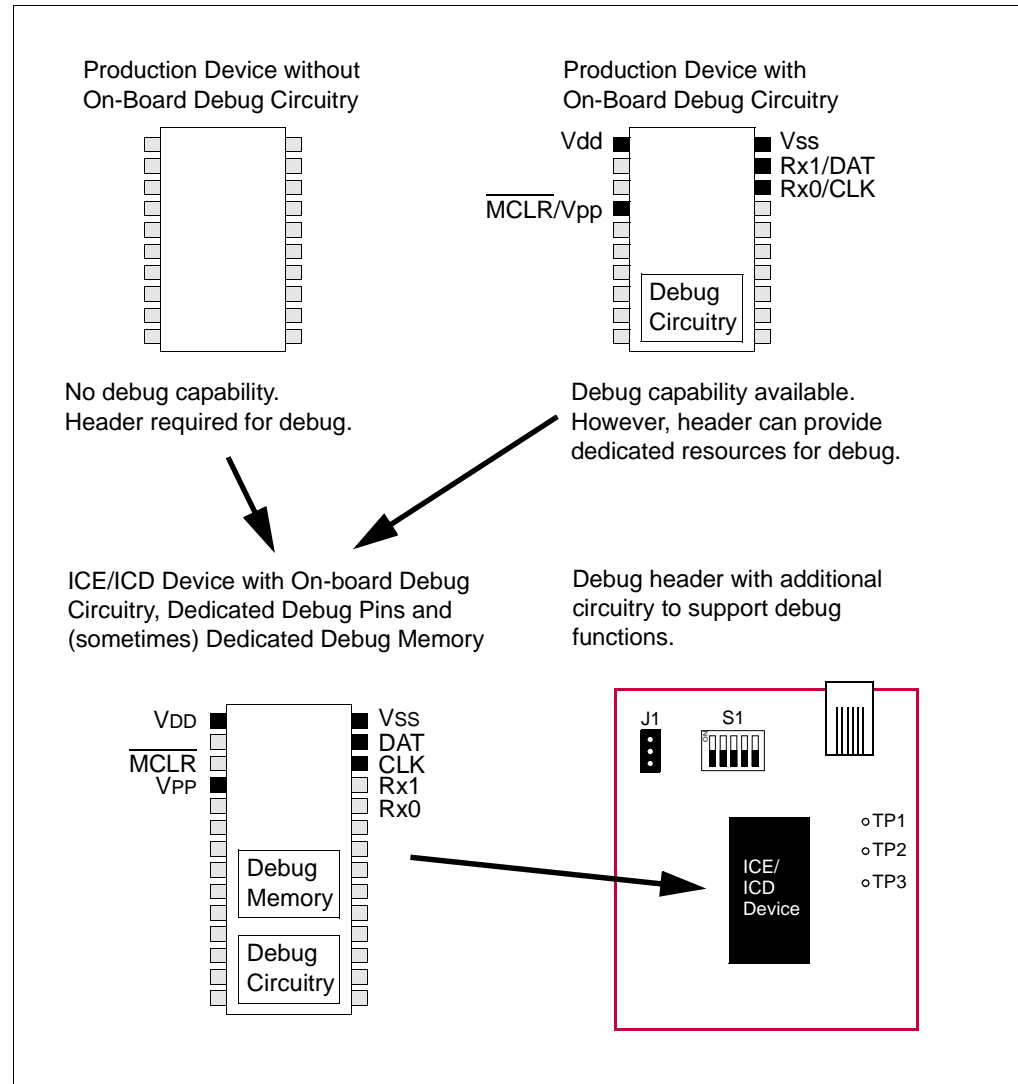

In general, ICE devices are designed for next-generation in-circuit emulator use and ICD devices are designed for in-circuit debugger use. However, ICE devices may be used with an in-circuit debugger and ICD devices may be used with a next-generation in-circuit emulator, but will provide only basic ICD functionality.

To determine what device resources must be dedicated to debugging for either a device with on-board debug capability or the special ICE/ICD device, see the “Resources used by ...” section of the in-circuit emulator or in-circuit debugger online Help file.

# Processor Extension Pak and Header Specification

---

## PROGRAMMING DETAILS

The debug header is designed to be used with the in-circuit emulator or the in-circuit debugger selected as a debugger, not a programmer, in MPLAB IDE or MPLAB X IDE. Any programming of the ICE/ICD device on the header is for debug purposes and includes the debug executive. See your related debug tool documentation for details on using it as a debugger.

To program production (non-ICE/ICD) devices with your debug tool, use the Universal Programming Module (AC162049) or design a modular interface connector on the target. See the appropriate specification for connections. For the most up-to-date device programming specifications, see the Microchip website ([www.microchip.com](http://www.microchip.com)).

Also, production devices may be programmed with the following tools:

- MPLAB PM3 device programmer
- PICSTART® Plus development programmer
- PICKit™ 1, 2 or 3 development programmer
- MPLAB ICD 3 in-circuit debugger (select as a programmer)
- MPLAB REAL ICE in-circuit emulator (select as a programmer)

## GENERAL HEADER SETUP

To set up your header, do the following:

1. Check the debug header for any stickers and the header box for any paper inserts that may specify special operating instructions (Figure 3). Follow these instructions before doing anything else.

**FIGURE 3: SPECIAL HEADER INSTRUCTIONS**

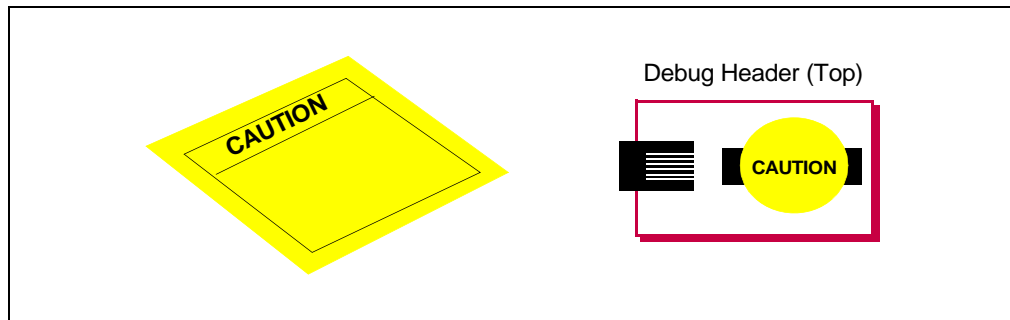

2. Set any jumpers or switches on the header to determine device functionality or selection as specified for that header. See the sections “Optional Debug Headers” or “Required Debug Headers” for information on how to set up individual headers.
3. Connect the header to your desired debug tool by consulting the tool documentation for connection options. An example connection is shown in Figure 4.

The special ICE/ICD device is mounted on the top of a header and its signals are routed to the emulator or debugger connector. These special device versions are labeled with the appropriate suffix (i.e., either *Device-ICE* or *Device-ICD*).

**FIGURE 4: CONNECT HEADER TO DEBUG TOOL**

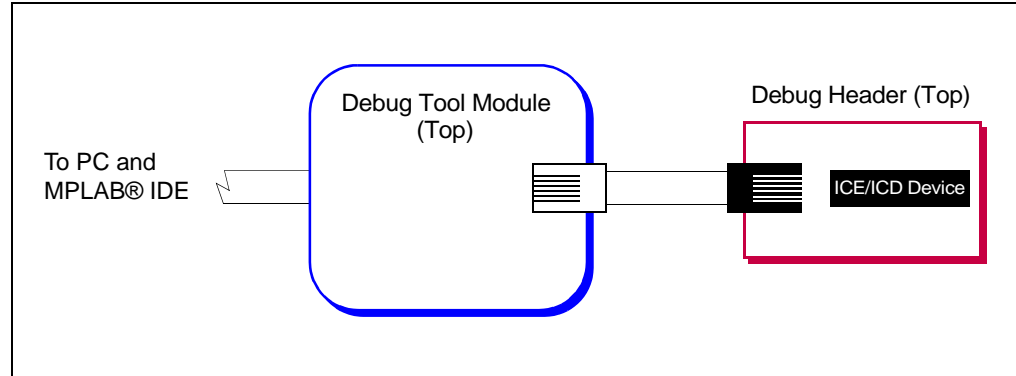

4. Connect the header to the target board. On the bottom of the header is a socket that is used to connect to the target board. The header may be connected to the target board as follows:
  - a) PDIP header socket to PDIP target socket with a stand-off (male-to-male) connector
  - b) Header socket to plug on the target board
  - c) Header socket to target socket with a transition socket (see the “*Transition Socket Specification*”, DS51194)

An example connection is shown in Figure 5.

The header socket will have the same pin count as your selected device. The ICE/ICD device on the top of the header usually has a larger pin count because it has additional pins that are dedicated to debug.

**FIGURE 5: CONNECT HEADER TO TARGET**

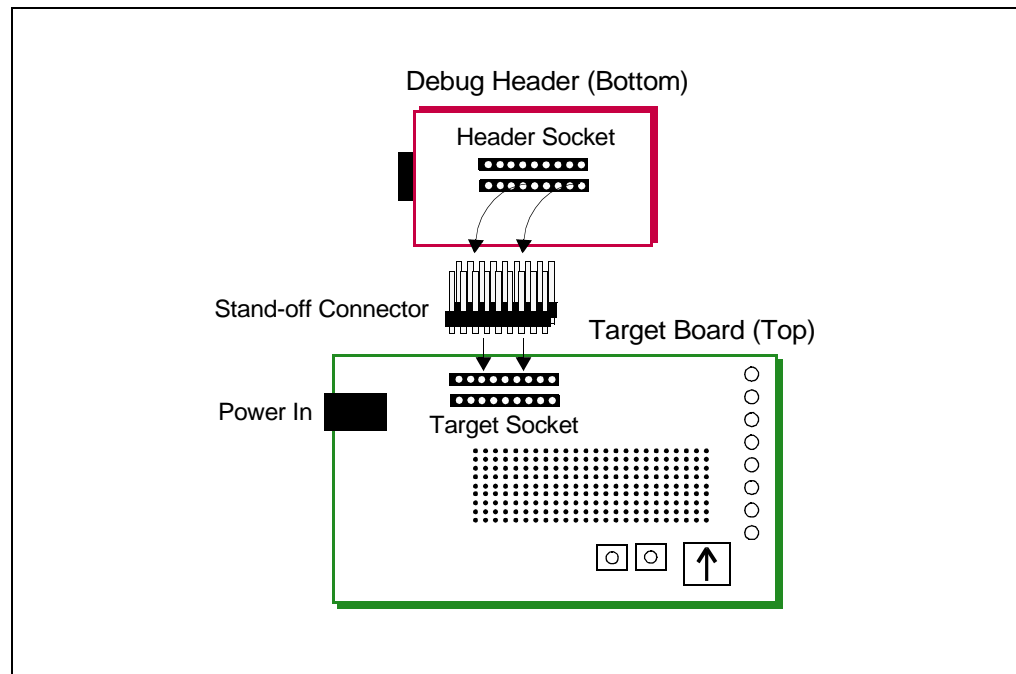

5. If using a debug tool that can power the target, power that tool now.
6. Power the target, if needed.

# Processor Extension Pak and Header Specification

## DEVICE VS. OPTIONAL HEADER FEATURES

For some devices that have on-board debug capability, the optional header provides more debug features than the device itself. To determine if your device and optional header differ in their debug features, go to the DTS to look up your device:

1. In a web browser, go to: <http://www.microchip.com/dtsapp/>
2. Enter your device and click the **Search** button.
3. Select the package you will use.
4. Compare the device features under “Debug Features” to the header features under “Header Debug Features”.

FIGURE 6: DTS DEVICE INFORMATION





The screenshot displays the 'Development Tools Selector' web application. On the left, a search bar contains 'PIC16F1934' and a 'Search' button. Below it, a table lists device packages: 40MV, 40P, 44ML, and 44PT. The main area shows details for the selected device, 'PIC16F1934', and its headers. The headers are categorized into 'Emulator/In-Circuit Debugger', 'Device Adapter/Header', and 'Transition Socket'. The 'Device Adapter/Header' section lists three options: PG164130, DV164035, and DV244005. Each header entry includes a product image, a 'Debug Features' section, and a 'Header Debug Features' section. The 'Debug Features' section lists hardware and software breakpoints for program and data memory. The 'Header Debug Features' section lists hardware and software breakpoints for program and data memory, and data capture capabilities. A 'Print' button is located at the bottom of the page.

Device	Package
PIC16F1934	40MV
	40P
	44ML
	44PT

Device	Package
PIC16F1934	44PT

Emulator/In-Circuit Debugger	Device Adapter/Header	Transition Socket
PG164130 	AC244035 +  Header Debug Features Pgm-memory HW breakpoints:3 Data-memory breakpoints:3	
DV164035 	AC244035 +  Header Debug Features Pgm-memory HW breakpoints:3 Data-memory breakpoints:3 Pgm-memory SW breakpoints:Unlimited	
DV244005 	AC244035 +  Header Debug Features Pgm-memory HW breakpoints:3 Data-memory breakpoints:3 Data capture:Enabled Pgm-memory SW breakpoints:Unlimited	
DV164005 	AC244035 +	

## MPLAB IDE AND MPLAB X IDE USE WITH HEADERS

### MPLAB IDE v8

Perform the following steps to use the debug header:

1. Set up the debug header as specified in “General Header Setup”.
2. Create a project for a device supported by your debug header using the Project wizard (*Project>Project Wizard*). See MPLAB IDE v8 documentation for more on Projects.
3. Under *Debugger>Select Tool*, select the debug tool to which your header is attached.

**Note:** A debug header can be used only in debug mode, not in programming mode. See “Programming Details”.

4. Write code for your project and build it until there are no errors.
5. Select *Debugger>Program* and then *Debugger>Run* to run your debug code.

### MPLAB X IDE

Perform the following steps to use the debug header:

1. Set up the debug header as specified in “General Header Setup”.
2. Begin creating a project for a device supported by your debug header using the Projects wizard (*File>New Project*). See MPLAB X IDE documentation for more on Projects.
3. In one step of the wizard you will have an opportunity to specify the header.
4. In another step you will specify the hardware (debug) tool to which your header is attached.
5. Once the wizard is complete, write code for your project.
6. Select *Debug>Debug Project* to run and debug your code.

**Note:** A debug header can be used only to debug (Debug menu), not to program (Run menu). See “Programming Details”.

## CALIBRATION BITS

The calibration bits for the band gap and internal oscillator are always preserved to their factory settings.

## PERFORMANCE ISSUES

The PIC<sup>®</sup> MCU devices do not support partial program memory erase; therefore, users may experience slower performance than with other devices.

Also, see either the in-circuit emulator or the in-circuit debugger Help file for information on specific device limitations that may affect performance.

## RELATED DEBUG TOOLS

The following tools support the use of headers:

- MPLAB REAL ICE In-Circuit Emulator
- MPLAB ICD 2 or 3 In-Circuit Debugger
- PICkit 2 or 3 Debug Express

See the Microchip website for the latest documentation:

<http://www.microchip.com>

# Processor Extension Pak and Header Specification

---

## CUSTOMER SUPPORT

Users of Microchip products can receive assistance through several channels:

- Distributor or Representative
- Local Sales Office
- Field Application Engineer (FAE)
- Technical Support

Customers should contact their distributor, representative or field application engineer (FAE) for support. Local sales offices are also available to help customers.

Technical support is available through the web site at:

<http://support.microchip.com>

Documentation errors or comments may be sent to [docerrors@microchip.com](mailto:docerrors@microchip.com).



## Required Debug Headers

### INTRODUCTION

Some devices have no built-in debug circuitry. Therefore, special ICE/ICD versions of these devices are required for debug tool operation.

Currently available debug headers and their associated ICE/ICD devices are shown below, sorted by supported device.

**TABLE 1: REQUIRED DEBUG HEADERS BY DEVICE**

Device	Pin Count	Header Part Number	ICE/ICD Device Used	VDD Max
PIC10F200/2/4/6	8/14	<a href="#">AC162059</a>	PIC16F505-ICD	5.5V
PIC10F220/2	8/14	<a href="#">AC162070</a>	PIC16F506-ICD	5.5V
PIC10F320/322	6/8	<a href="#">AC244045</a>	PIC10F320-ICE	5.5V
PIC10LF320/322	6/8	<a href="#">AC244045</a>	PIC10F320-ICE	3.6V
PIC12F508/509	8/14	<a href="#">AC162059</a>	PIC16F505-ICD	5.5V
PIC12F510	8/14	<a href="#">AC162070</a>	PIC16F506-ICD	5.5V
PIC12F519	8/14	<a href="#">AC162096</a>	PIC16F526-ICD	5.5V
PIC12F609/HV609	28	<a href="#">AC162083</a>	PIC16F616-ICD	5.5V
PIC12F615/HV615	28	<a href="#">AC162083</a>	PIC16F616-ICD	5.5V
PIC12F617	28	<a href="#">AC162083</a>	PIC16F616-ICD	5.5V
PIC12F629	8	<a href="#">AC162050</a>	PIC12F675-ICD	5.5V
PIC12F635	14	<a href="#">AC162057</a>	PIC16F636-ICD	5.5V
PIC12F675	8	<a href="#">AC162050</a>	PIC12F675-ICD	5.5V
PIC12F683	8	<a href="#">AC162058</a>	PIC12F683-ICD	5.5V
PIC12F1501 <sup>(1)</sup>	8	<a href="#">AC244051</a>	PIC16F1509-ICE	5.5V
PIC12LF1501 <sup>(1)</sup>	8	<a href="#">AC244052</a>	PIC16LF1509-ICE	3.6V
PIC16F505	8/14	<a href="#">AC162059</a>	PIC16F505-ICD	5.5V
PIC16F506	8/14	<a href="#">AC162070</a>	PIC16F506-ICD	5.5V
PIC16F526	8/14	<a href="#">AC162096</a>	PIC16F526-ICD	5.5V
PIC16F610/HV610	14/16	<a href="#">AC162083</a>	PIC16F616-ICD	5.5V
PIC16F616/HV616	14/16	<a href="#">AC162083</a>	PIC16F616-ICD	5.5V
PIC16F627A/628A	18	<a href="#">AC162053</a>	PIC16F648A-ICD	5.5V
PIC16F630	14	<a href="#">AC162052</a>	PIC16F676-ICD	5.5V

**Note 1:** Header optional for other devices

**2:** VDDCORE Max

**3:** Dual die

# Processor Extension Pak and Header Specification

**TABLE 1: REQUIRED DEBUG HEADERS BY DEVICE (CON'T)**

Device	Pin Count	Header Part Number	ICE/ICD Device Used	VDD Max
PIC16F631	20	<a href="#">AC162061</a>	PIC16F690-ICD	5.5V
PIC16F636	14	<a href="#">AC162057</a>	PIC16F636-ICD	5.5V
PIC16F639 <sup>(3)</sup>	20	<a href="#">AC162066</a>	PIC16F636-ICD	5.5V
PIC16F648A	18	<a href="#">AC162053</a>	PIC16F648A-ICD	5.5V
PIC16F676	14	<a href="#">AC162052</a>	PIC16F676-ICD	5.5V
PIC16F677	20	<a href="#">AC162061</a>	PIC16F690-ICD	5.5V
PIC16F684	14	<a href="#">AC162055</a>	PIC16F684-ICD	5.5V
PIC16F685/687	20	<a href="#">AC162061</a>	PIC16F690-ICD	5.5V
PIC16F688	14	<a href="#">AC162056</a>	PIC16F688-ICD	5.5V
PIC16F689/690	20	<a href="#">AC162061</a>	PIC16F690-ICD	5.5V
PIC16F716	18	<a href="#">AC162054</a>	PIC16F716-ICD	5.5V
PIC16F785/HV785	20	<a href="#">AC162060</a>	PIC16F785-ICD	5.5V
PIC16F1503 <sup>(1)</sup> PIC16F1507 <sup>(1)</sup>	14 20	<a href="#">AC244051</a>	PIC16F1509-ICE	5.5V
PIC16LF1503 <sup>(1)</sup> PIC16LF1507 <sup>(1)</sup>	14 20	<a href="#">AC244052</a>	PIC16LF1509-ICE	3.6V
PIC18F13K50 PIC18F14K50	20	<a href="#">AC244023</a>	PIC18F14K50-ICE	5.5V
PIC18LF13K50 PIC18LF14K50	20	<a href="#">AC244024</a>	PIC18LF14K50-ICE	3.6V 2.75V <sup>(2)</sup>
PIC24F04KA200 <sup>(1)</sup> PIC24F04KA201 <sup>(1)</sup>	14 20	<a href="#">AC244028</a>	PIC24F16KA102-ICE	3.6V

**Note 1:** Header optional for other devices

**2:** VDDCORE Max

**3:** Dual die

# Required Debug Headers

---

## AC162050, AC162058

### Header Identification

The header AC number is used for ordering the header. However, this number is not on the debug header, as the board is often used for multiple headers by inserting different ICE/ICD devices. To identify these debug headers, use the following information.

Header	ICE/ICD Device	Board Assembly Number
AC162050	PIC12F675-ICD	02-01662
AC162058	PIC12F683-ICD	

### Header Setup and Operation

For these headers, device peripherals need to be selected by setting jumper J1 to the appropriate position. For AC162050, this will have the effect of selecting the device.

Header	Jumper J1	Function	Device Selected
AC162050	2-3	A/D Disabled	PIC12F629
	1-2	A/D Enabled	PIC12F675
AC162058	1-2	A/D Enabled	PIC12F683

### Header Limitations

See the "Limitations" section in your debug tool online Help file for details.

# Processor Extension Pak and Header Specification

## Header Dimensions

The figure below lists the dimensions for the debug header. Dimensions are design values in inches.

If the length and/or width of the debug header is too large a footprint for the target board, consider using stand-offs, transition sockets or other extenders in the header connection socket to raise the header above the target.

**FIGURE 1: DIMENSIONS – AC162050, AC162058**

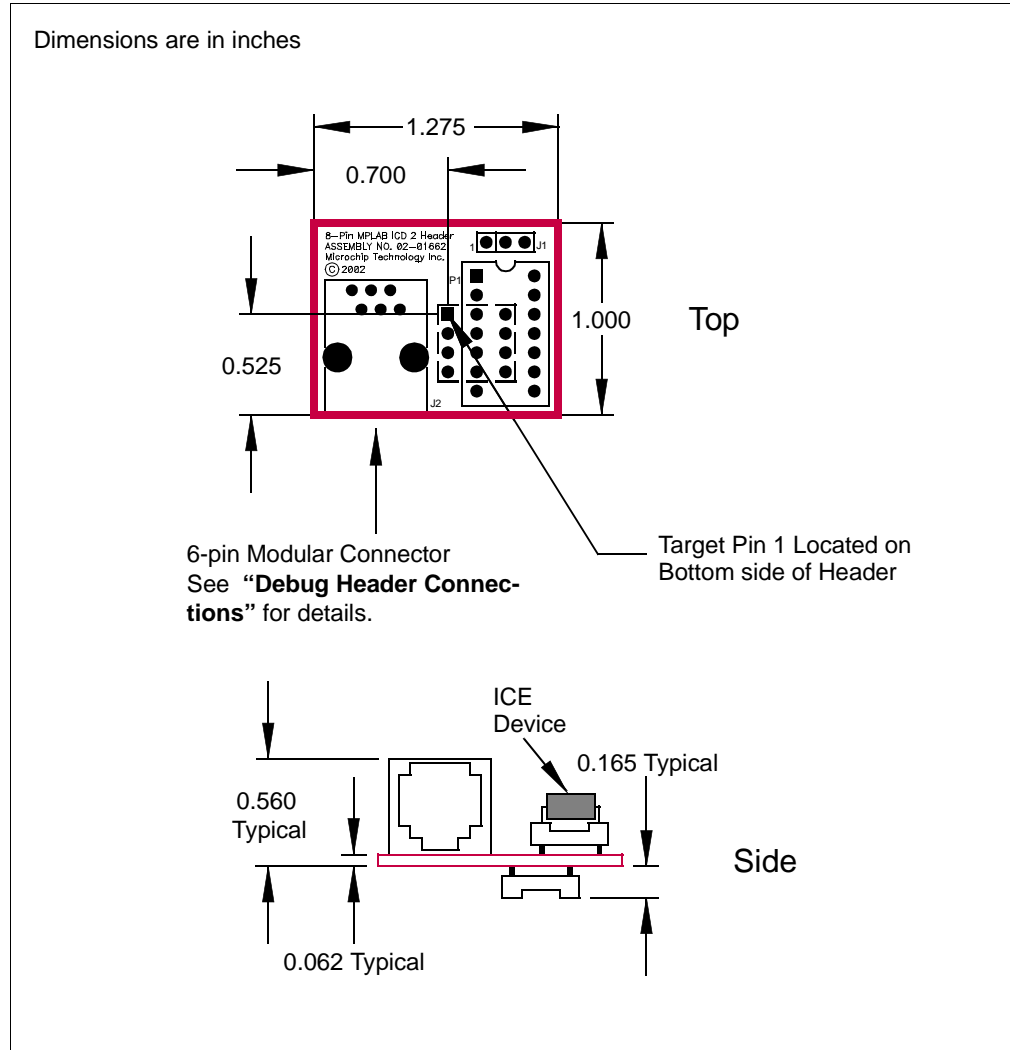

# Required Debug Headers

## AC162052, AC162055, AC162056, AC162057

### Header Identification

The header AC number is used for ordering the header. However, this number is not on the debug header, as the board is often used for multiple headers by inserting different ICE/ICD devices. To identify these debug headers, use the following information.

Header	ICE/ICD Device	Board Assembly Number
AC162052	PIC16F676-ICD	02-01686
AC162055	PIC16F684-ICD	
AC162056	PIC16F688-ICD	
AC162057	PIC16F636-ICD	

### Header Setup and Operation

For these headers, device peripherals need to be selected by setting jumper J1 to the appropriate position. For AC162052 and AC162057, this will have the effect of selecting the device.

Header	Jumper J1	Function	Device Selected
AC162052	2-3	A/D Disabled	PIC16F630
	1-2	A/D Enabled	PIC16F676
AC162055	Don't care	N/A	PIC16F684
AC162056	Don't care	N/A	PIC16F688
AC162057	2-3	PORTC, Comparator 2 Disabled	PIC12F635
	1-2	PORTC, Comparator 2 Enabled	PIC16F636

### Header Limitations

See the "Limitations" section in your debug tool online Help file for details.

# Processor Extension Pak and Header Specification

## Header Dimensions

The figure below lists the dimensions for the debug header. Dimensions are design values in inches.

If the length and/or width of the debug header is too large a footprint for the target board, consider using stand-offs, transition sockets or other extenders in the header connection socket to raise the header above the target.

**FIGURE 2: DIMENSIONS – AC162052, AC162055, AC162056, AC162057**

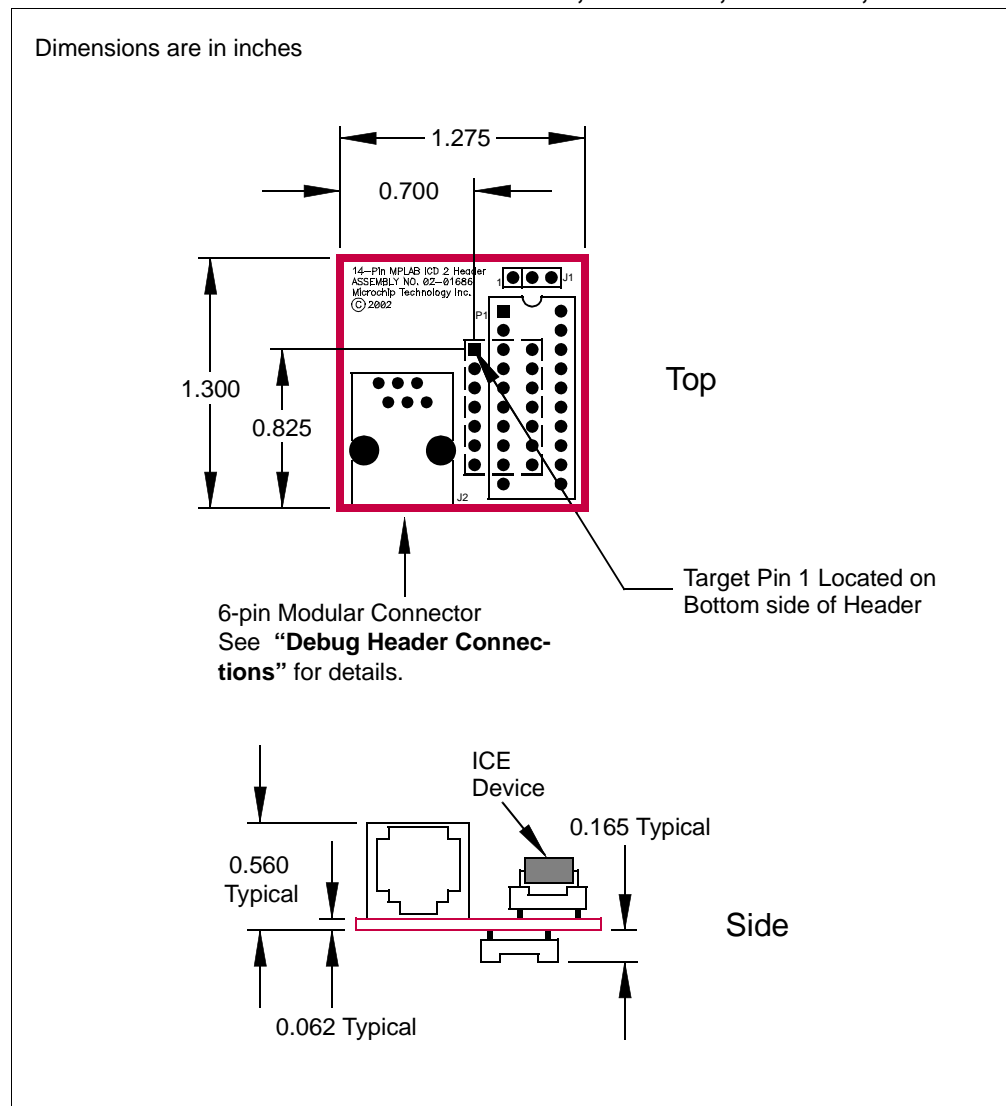

## AC162053, AC162054

### Header Identification

The header AC number is used for ordering the header. However, this number is not on the debug header, as the board is often used for multiple headers by inserting different ICE/ICD devices. To identify these debug headers, use the following information.

Header	ICE/ICD Device	Board Assembly Number
AC162053	PIC16F648A-ICD	02-01695
AC162054	PIC16F716-ICD	

### Header Setup and Operation – AC162053

For this headers, there are no jumpers/switches. The device with the most program memory is always selected.

If PIC16F627A or PIC16F628A devices are selected for development in MPLAB IDE or MPLAB X IDE, the warning “Invalid target device ID” may be received in the build window and as a dialog. The reason is the PIC16F648A-ICD device supports PIC16F648A, PIC16F627A and PIC16F628A, but only reports the device ID for the PIC16F648A.

Ignore this warning or disable it under the **Warnings** tab on the ICD Programming dialog.

### Header Setup and Operation – AC162054

This header supports one device (PIC16F716) so there are no jumpers or switches.

### Header Limitations

See the “Limitations” section in your debug tool online Help file for details.

# Processor Extension Pak and Header Specification

## Header Dimensions

The figure below lists the dimensions for the debug header. Dimensions are design values in inches.

If the length and/or width of the debug header is too large a footprint for the target board, consider using stand-offs, transition sockets or other extenders in the header connection socket to raise the header above the target.

**FIGURE 3: DIMENSIONS – AC162053, AC162054**

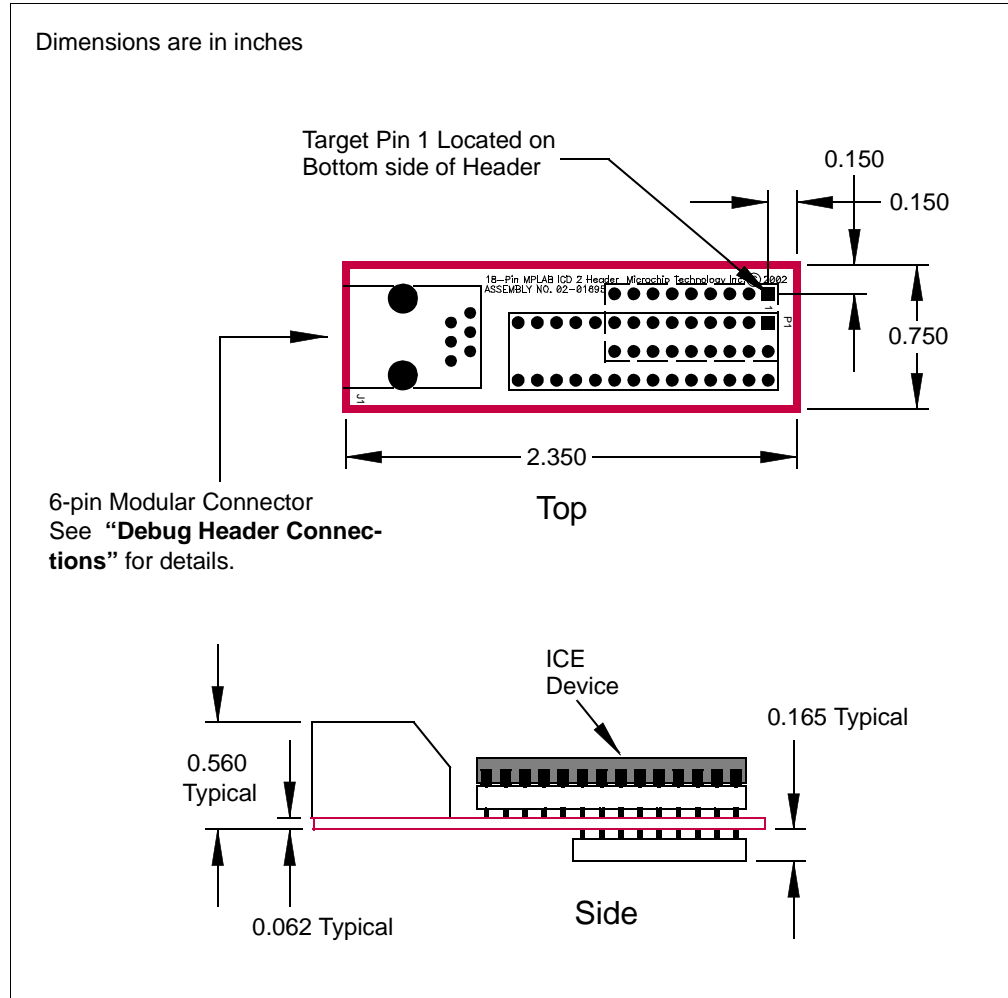



# Required Debug Headers

---

## AC162059, AC162070, AC162096

### Header Identification

The header AC number is used for ordering the header. However, this number is not on the debug header, as the board is often used for multiple headers by inserting different ICE/ICD devices. To identify these debug headers, use the following information.

Header	ICE/ICD Device	Board Assembly Number
AC162059	PIC16F505-ICD	02-01803
AC162070	PIC16F506-ICD	
AC162096	PIC16F526-ICD	

### Header Setup and Operation

The ICD devices on these headers are specifically designed to select a device without the use of additional jumpers or switches.

These headers support 8 and 14-pin devices (see Figure 4.) For the AC162059 and AC162070, there is an 8-pin and a 14-pin connector. For the AC162096, there is only a 14-pin connector. (The 8-pin connector is not populated.) Use the 14-pin connector for 8-pin devices, but make sure device pin 1 is placed at the 14-pin connector pin 1.

### Header Limitations

See the “Limitations” section in your debug tool online Help file for details.

# Processor Extension Pak and Header Specification

## Header Dimensions

The figure below lists the dimensions for the debug header. Dimensions are design values in inches.

If the length and/or width of the debug header is too large a footprint for the target board, consider using stand-offs, transition sockets or other extenders in the header connection socket to raise the header above the target.

**FIGURE 4: DIMENSIONS – AC162059, AC162070, AC162096**

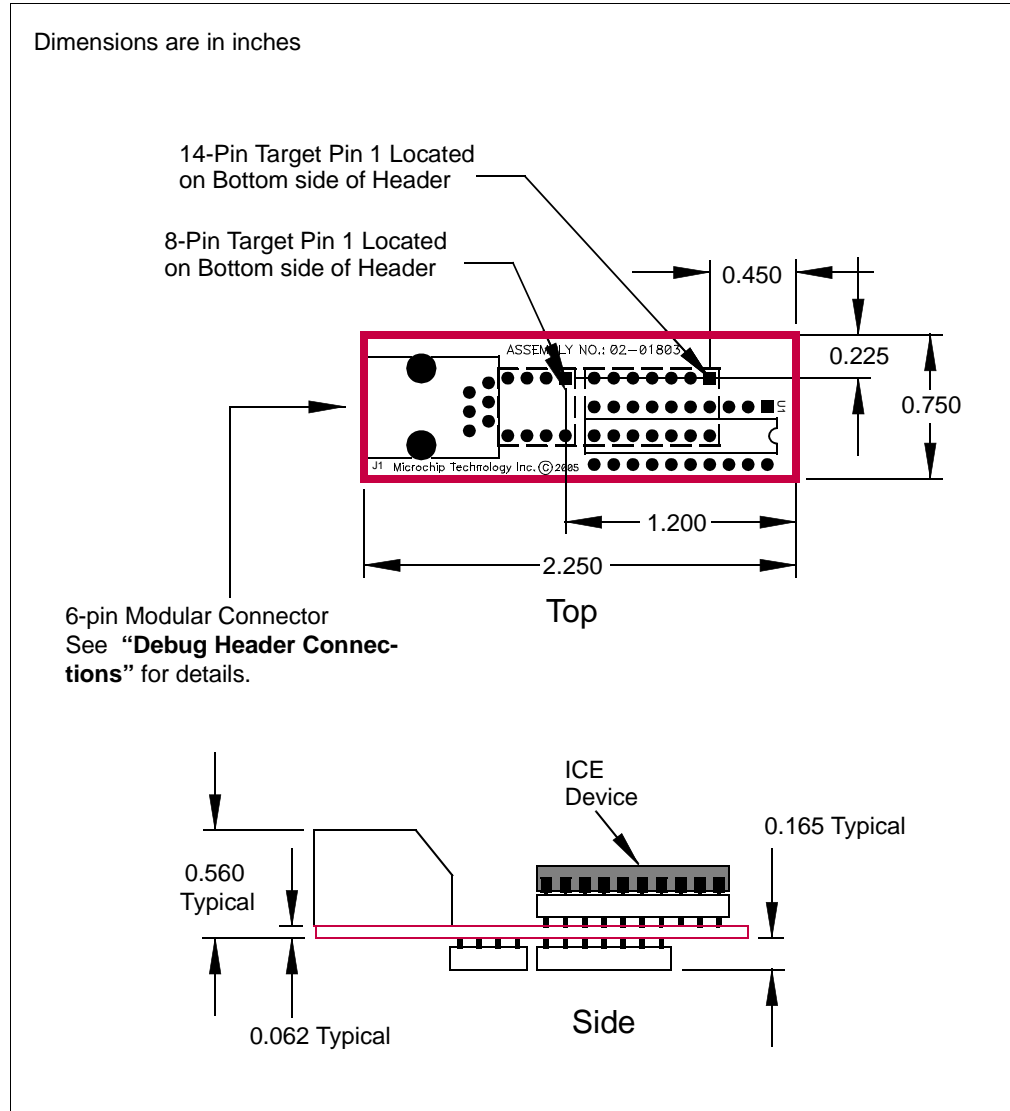

## AC162060

### Header Identification

The header AC number is used for ordering the header. However, this number is not on the debug header, as the board is often used for multiple headers by inserting different ICE/ICD devices. To identify this debug header, use the following information.

Header	ICE/ICD Device	Board Assembly Number
AC162060	PIC16F785-ICD	02-01820

### Header Setup and Operation

For the PIC16F785 20-pin header, you will need to connect the jumper J2 to enable the shunt regulator.

Device	Device Type	Jumper J2	Function
PIC16F785	F	1-2	Disable shunt regulator
PIC16HV785	HV	2-3	Enable shunt regulator

### Header Limitations

See the "Limitations" section in your debug tool online Help file for details.

# Processor Extension Pak and Header Specification

## Header Dimensions

The figure below lists the dimensions for the debug header. Dimensions are design values in inches.

If the length and/or width of the debug header is too large a footprint for the target board, consider using stand-offs, transition sockets or other extenders in the header connection socket to raise the header above the target.

**FIGURE 5: DIMENSIONS – AC162060**

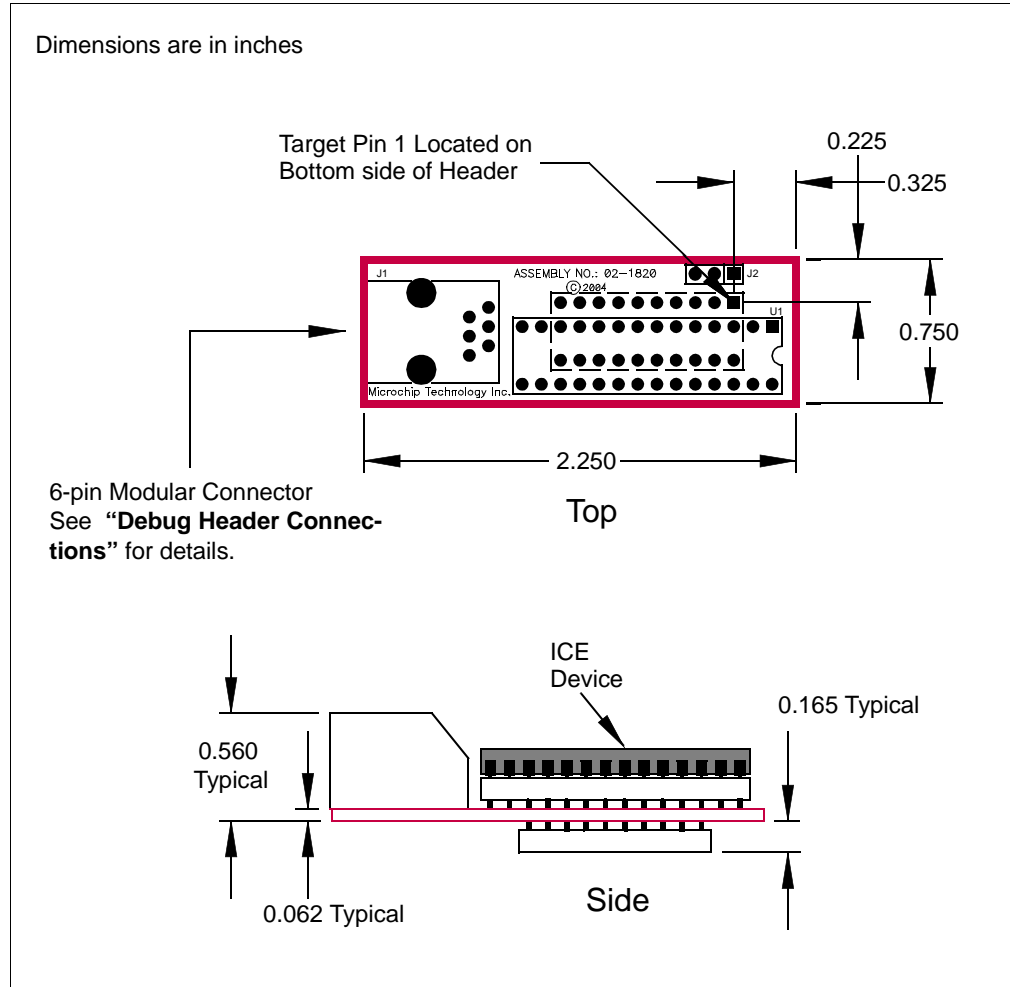

## AC162061

### Header Identification

The header AC number is used for ordering the header. However, this number is not on the debug header, as the board is often used for multiple headers by inserting different ICE/ICD devices. To identify this debug header, use the following information.

Header	ICE/ICD Device	Board Assembly Number
AC162061	PIC16F690-ICD	02-01835

### Header Setup and Operation

For the PIC16F690 20-pin header, you will need to set the S1 switches (Figure 6) to enable peripherals and choose devices (Table 2).

**FIGURE 6: S1 SWITCH HARDWARE**

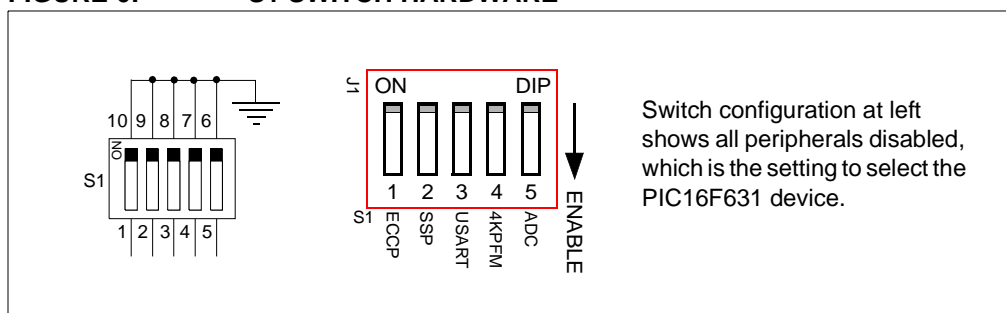

**TABLE 2: S1 SWITCH DEVICE SELECTION**

Device	Switches				
	1 ECCP	2 SSP	3 USART	4 4k PFM	5 ADC
PIC16F631	0	0	0	0*	0
PIC16F677	0	1	0	0**	1
PIC16F685	1	0	0	1	1
PIC16F687	0	1	1	0**	1
PIC16F689	0	1	1	1	1
PIC16F690	1	1	1	1	1

**Legend:** 1 = Enabled 0 = Disabled \* = 1k PFM \*\* = 2k PFM

### Header Limitations

See the “Limitations” section in your debug tool online Help file for details.

# Processor Extension Pak and Header Specification

## Header Dimensions

The figure below lists the dimensions for the debug header. Dimensions are design values in inches.

If the length and/or width of the debug header is too large a footprint for the target board, consider using stand-offs, transition sockets or other extenders in the header connection socket to raise the header above the target.

**FIGURE 7: DIMENSIONS – AC162061**

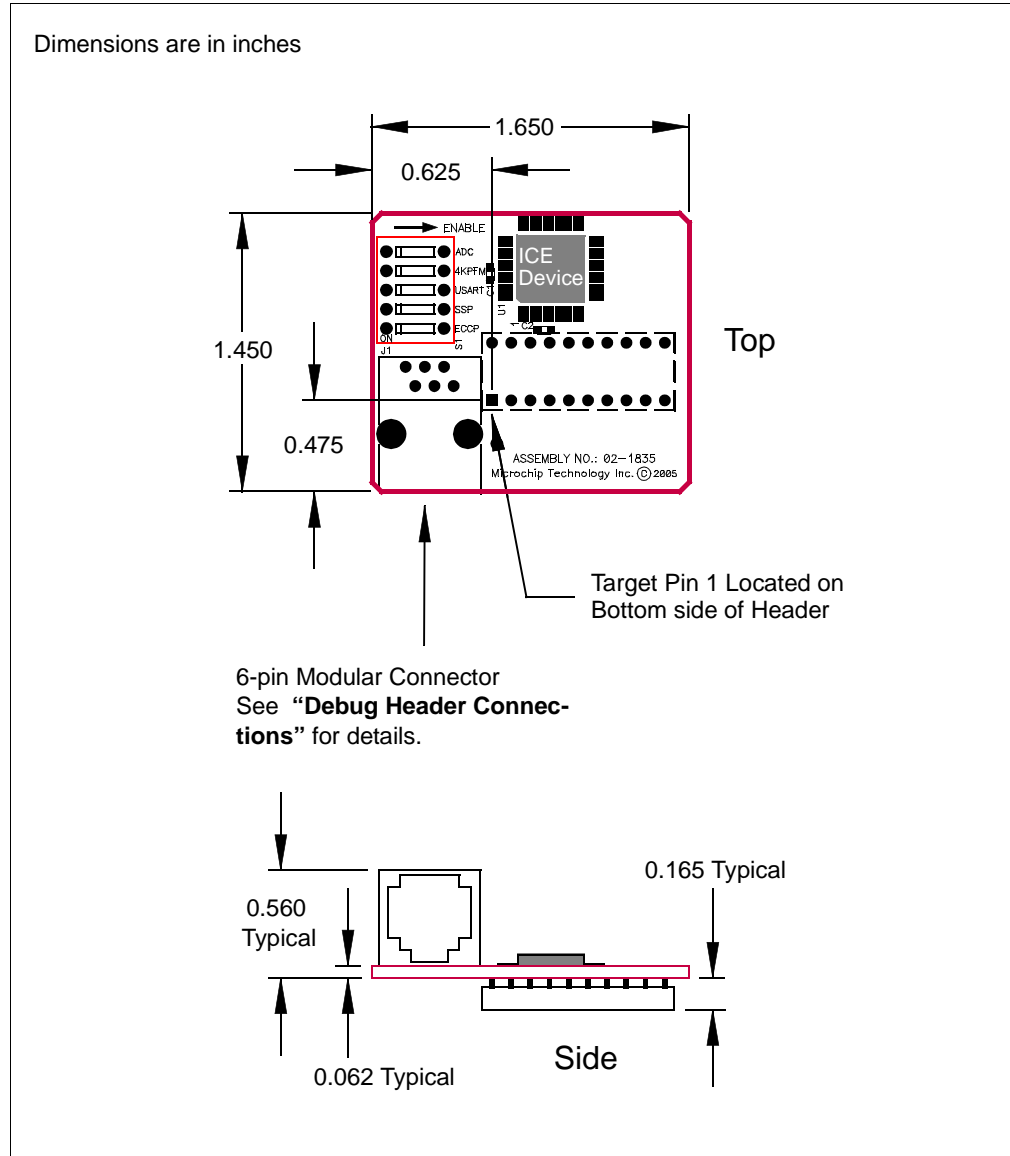

## AC162066

### Header Identification

The header AC number is used for ordering the header. However, this number is not on the debug header, as the board is often used for multiple headers by inserting different ICE/ICD devices. To identify this debug header, use the following information.

Header	ICE/ICD Device	Board Assembly Number
AC162066	PIC16F636-ICD	02-01832

### Header Setup and Operation

For the PIC16F639 20-pin header, you will need to connect the jumper J3 as specified below.

Tool	Jumper J3	Function
MPLAB <sup>®</sup> ICE 2000	1-2	Run/program as production device
In-circuit debuggers, next generation in-circuit emulators	2-3	Run/program as ICD device

In addition to being used with debug tools that normally use headers, this header is used with the PCM16YM0 processor module to emulate a PIC16F639 on the MPLAB ICE 2000 in-circuit emulator. Plug the end of the processor module into the header, and then plug the header into the transition socket or directly onto the target board.

### Header Limitations

See the "Limitations" section in your debug tool online Help file for details.

# Processor Extension Pak and Header Specification

## Header Dimensions

The figure below lists the dimensions for the debug header. Dimensions are design values in inches.

If the length and/or width of the debug header is too large a footprint for the target board, consider using stand-offs, transition sockets or other extenders in the header connection socket to raise the header above the target.

**FIGURE 8: DIMENSIONS – AC162066**

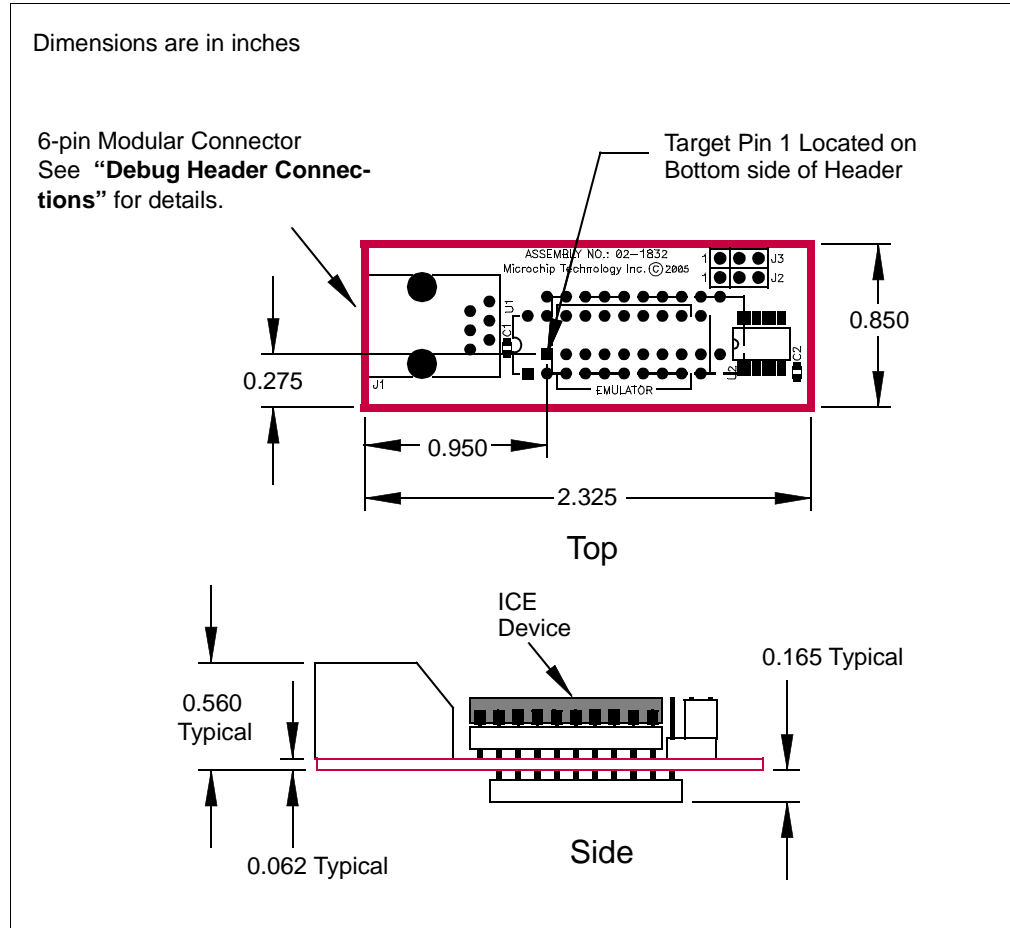



# Required Debug Headers

## AC162083

### Header Identification

The header AC number is used for ordering the header. However, this number is not on the debug header, as the board is often used for multiple headers by inserting different ICE/ICD devices. To identify this debug header, use the following information.

Header	ICE/ICD Device	Board Assembly Number
AC162083	PIC16F616-ICD	02-01976

### Header Setup and Operation

CAUTION	
	<p>Incorrect rotary switch (Figure 9) settings may irreparably damage the header.</p> <p>Ensure rotary switch settings are correct (Table 3) before powering or connecting the header.</p> <p>Do not change the rotary switch setting while the header is powered or connected to a debug tool.</p> <p>Do not power shunt regulator (HV) devices from the debug tool.</p>

Test points are available on this header to check the following: Ground (TP1), VDD (TP2), ICD Clock (TP3), ICD Data (TP4) and ICD MCLR/VPP (TP5).

**TABLE 3: ROTARY SWITCH SETTINGS**

Switch Position	Device	Switch Position	Device
0	<b>PIC12HV609</b>	8	<b>PIC12F609</b>
1	<b>PIC12HV615</b>	9	<b>PIC12F615</b>
2	Reserved HV	A	<b>PIC12F617</b>
3	<b>PIC16HV610</b>	B	<b>PIC16F610</b>
4	<b>PIC16HV616</b>	C	<b>PIC16F616</b>
5	Reserved HV	D	Reserved F
6	Reserved HV	E	Reserved F
7	Reserved HV	F	Reserved F

Also, see the AC162083 Insert (DS51693).

# Processor Extension Pak and Header Specification

---

## POTENTIAL ISSUES

### **HV device selected instead of F device**

If you inadvertently select a shunt regulator (HV) device and attempt to use it in a target board designed for a non-shunt regulator (F) device, the shunt may draw excessive current due to the lack of current-limiting circuitry on the target board and damage the device mounted on the header.

### **F device selected instead of HV device**

If you inadvertently select a non-shunt regulator (F) device and attempt to use it in a target board designed for a shunt regulator (HV) device, the device may draw excessive current due to the higher voltage used on a target board designed for HV devices and damage the device mounted on the header.

### **HV devices cannot be powered from debug tool**

Do not select in MPLAB IDE or MPLAB X IDE to power the target (debug header) from the debug tool (if it supports powering the target) when using shunt regulator (HV) devices, since this will also cause the shunt to draw excessive current.

## DETERMINING DAMAGE

A damaged header will cause MPLAB IDE or MPLAB X IDE to report a device ID of 0. However, there are other issues that can cause the device ID to report as 0. Please consult your debug tool documentation on troubleshooting to identify the problem. If you believe you have a damaged header, please contact Microchip technical support at <http://support.microchip.com>.

### **Header Limitations**

See the "Limitations" section in your debug tool online Help file for details.

# Required Debug Headers

## Header Dimensions

The figure below lists the dimensions for the debug header. Dimensions are design values in inches.

If the length and/or width of the debug header is too large a footprint for the target board, consider using stand-offs, transition sockets or other extenders in the header connection socket to raise the header above the target.

**FIGURE 9: DIMENSIONS – AC162083**

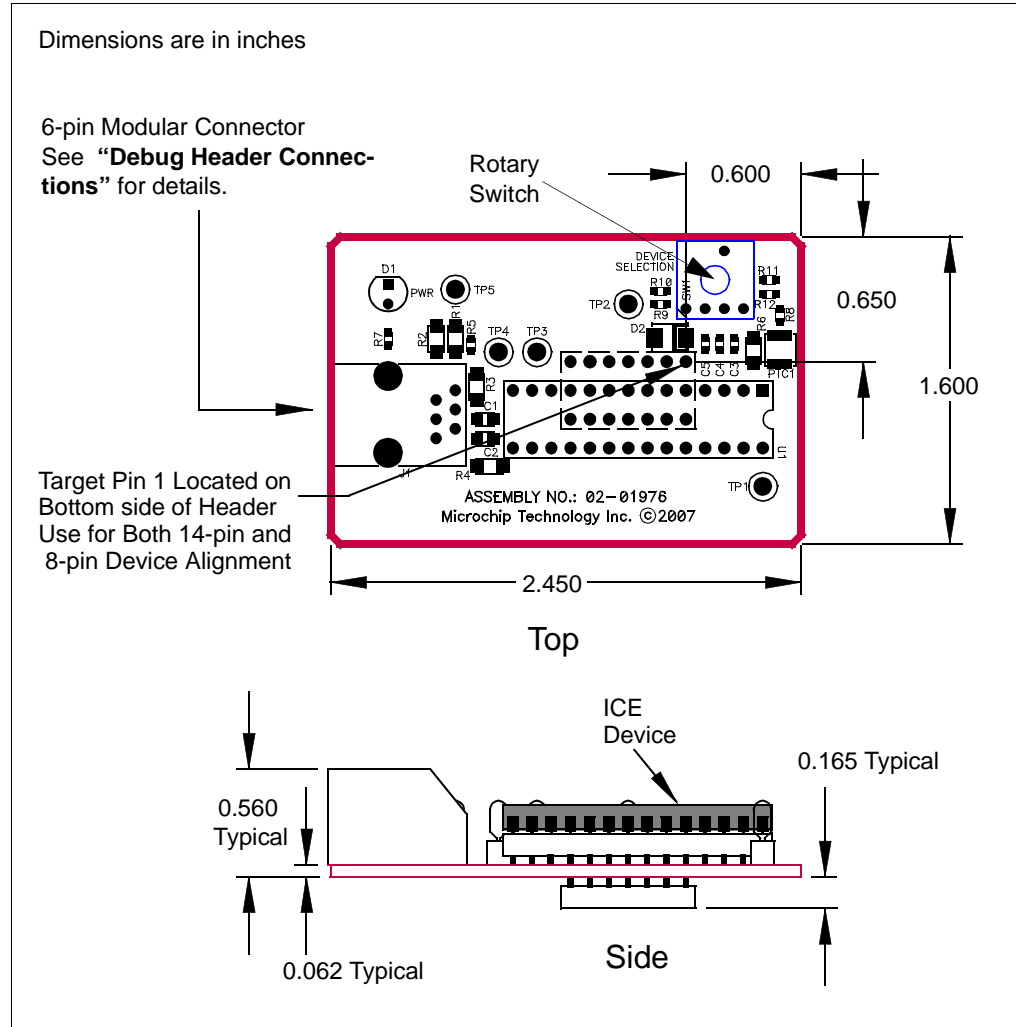

# Processor Extension Pak and Header Specification

## AC244023, AC244024

### Header Identification

The header AC number is used for ordering the header. However, this number is not on the debug header, as the board is often used for multiple headers by inserting different ICE/ICD devices. To identify these debug headers, use the following information.

Header	ICE/ICD Device	Board Assembly Number
AC244023	PIC18F14K50-ICE	02-02031
AC244024	PIC18LF14K50-ICE	

### Header Setup and Operation

When the MPLAB ICD 2 is used with this header, you must use the Vpp Limiter (AC164112).

**FIGURE 10: VPP LIMITER SCHEMATIC**

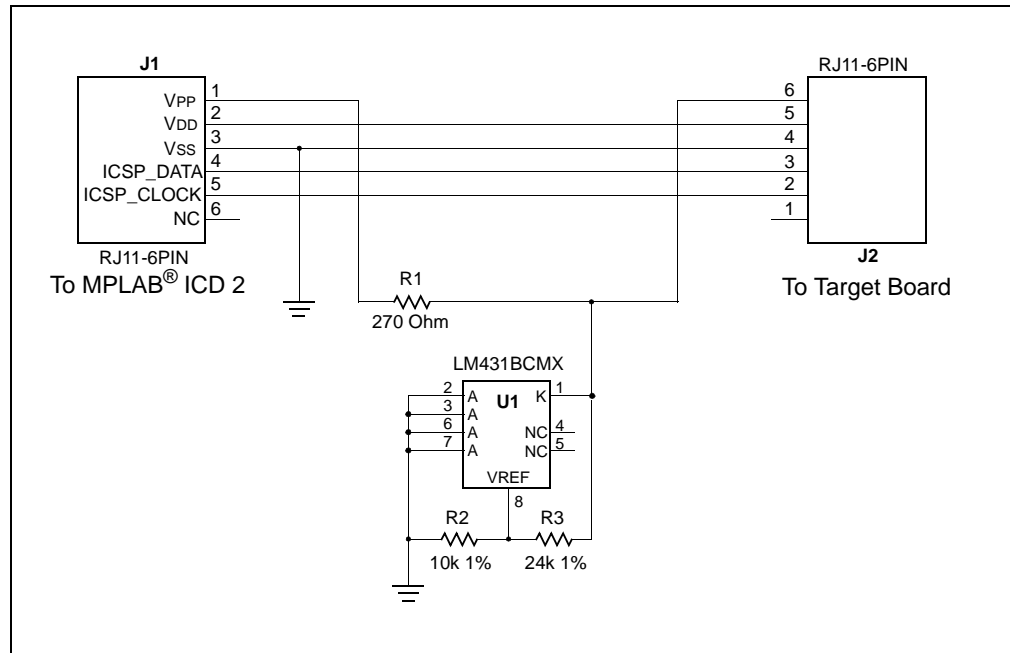

### Header Limitations

See the "Limitations" section in your debug tool online Help file for details.

# Required Debug Headers

## Header Dimensions

The figure below lists the dimensions for the debug header. Dimensions are design values in inches.

If the length and/or width of the debug header is too large a footprint for the target board, consider using stand-offs, transition sockets or other extenders in the header connection socket to raise the header above the target.

**FIGURE 11: DIMENSIONS – AC244023, AC224024**

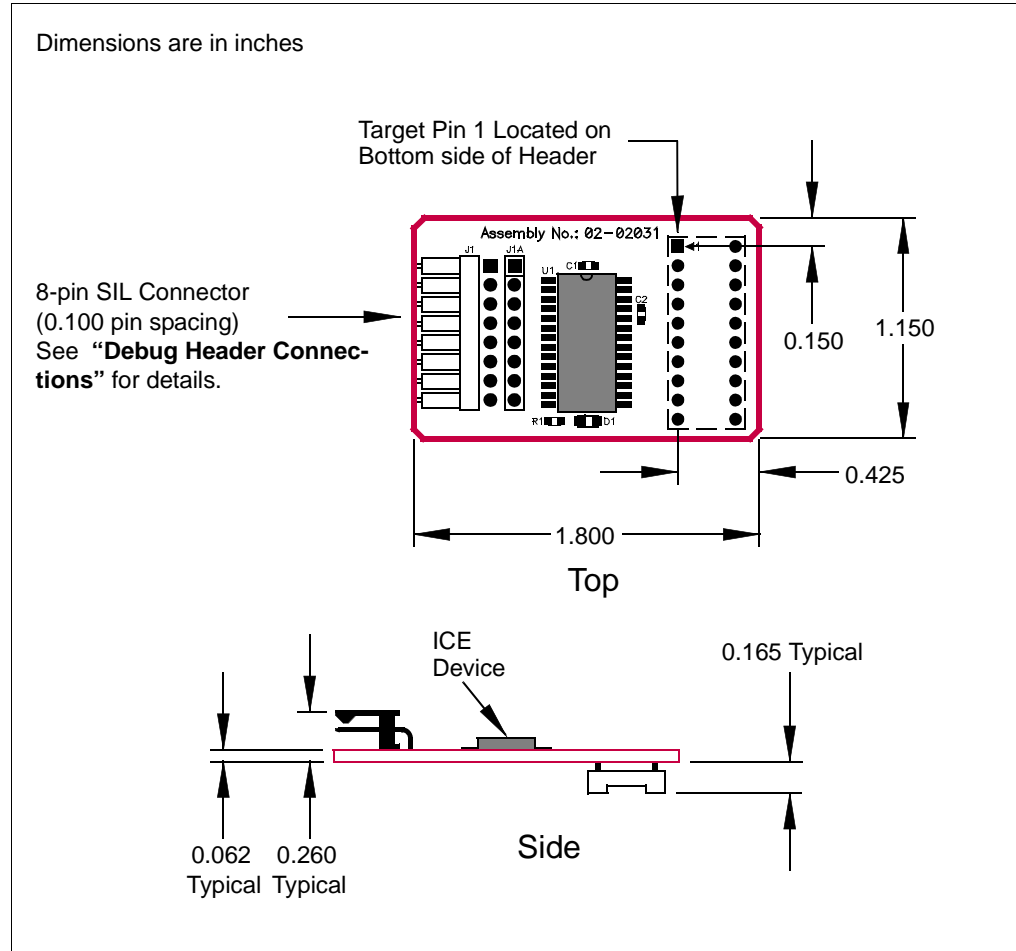

# Processor Extension Pak and Header Specification

---

## AC244028

### Header Identification

The header AC number is used for ordering the header. However, this number is not on the debug header, as the board is often used for multiple headers by inserting different ICE/ICD devices. To identify this debug header, use the following information.

Header	ICE/ICD Device	Board Assembly Number
AC244028	PIC24F16KA102-ICE	02-02107

### Header Setup and Operation

For this header, you will need to set up jumper J2 and J3.

Jumper	Setting	Function
J2	Open	Disable weak ICE/MCLR pull-up resistor
	Short	Enable weak ICE/MCLR pull-up resistor
J3	Open	Disable power LED indicator
	Short	Enable power LED indicator

### Header Limitations

See the "Limitations" section in your debug tool online Help file for details.

# Required Debug Headers

## Header Dimensions

The figure below lists the dimensions for the debug header. Dimensions are design values in inches.

If the length and/or width of the debug header is too large a footprint for the target board, consider using stand-offs, transition sockets or other extenders in the header connection socket to raise the header above the target.

**FIGURE 12: DIMENSIONS - AC244028**

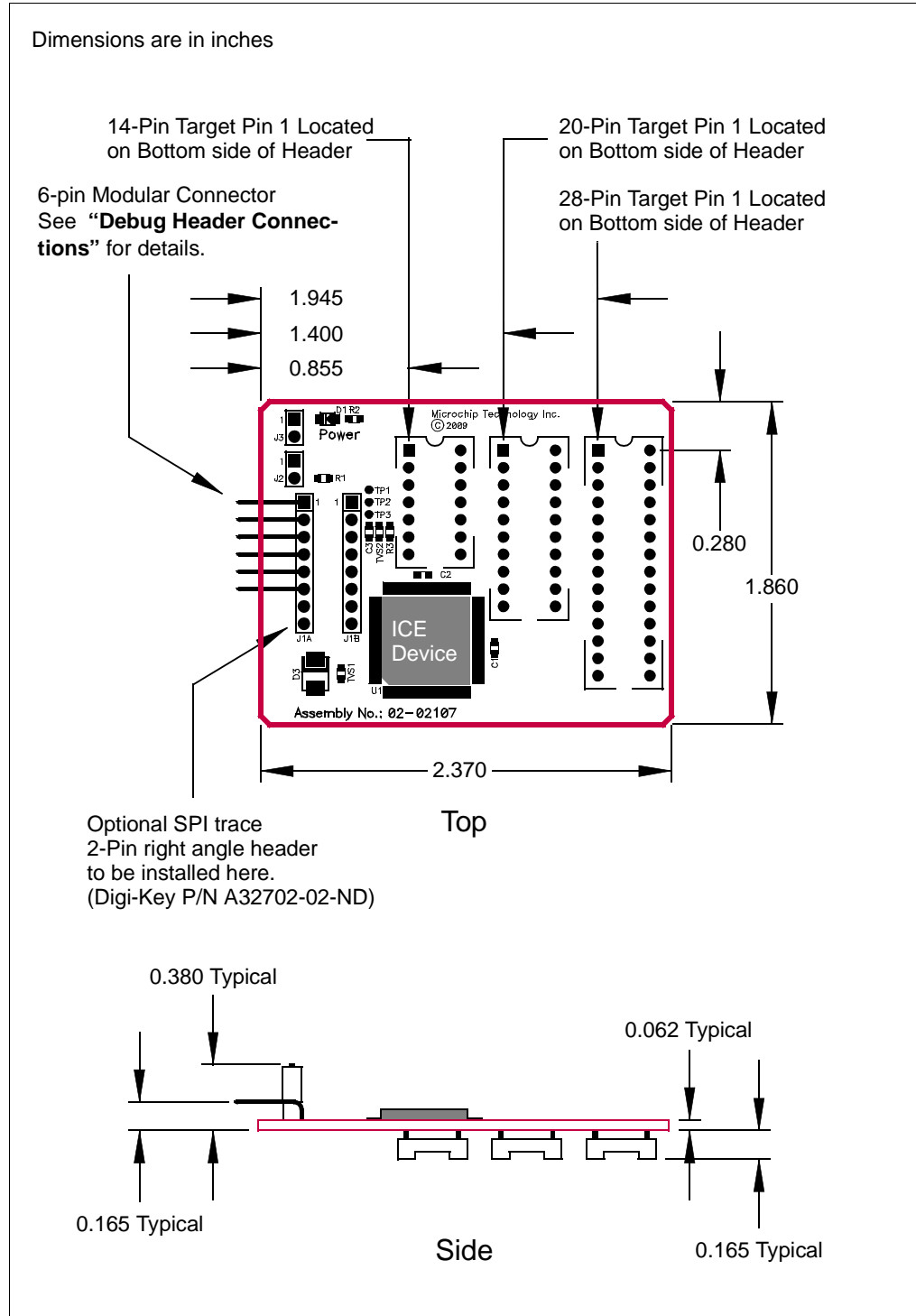

# Processor Extension Pak and Header Specification

---

## AC244045

### Header Identification

The header AC number is used for ordering the header. However, this number is not on the debug header, as the board is often used for multiple headers by inserting different ICE/ICD devices. To identify this debug header, use the following information.

Header	ICE/ICD Device	Board Assembly Number
AC244045	PIC10F320-ICE	02-02255

Because the ICE chip is based on the PIC10F320 device, the ICE device memory will be greater than the actual chip for the PIC10F322 device.

### Header Limitations

See the "Limitations" section in your debug tool online Help file for details.



# Required Debug Headers

## Header Dimensions

The figure below lists the dimensions for the debug header. Dimensions are design values in inches.

If the length and/or width of the debug header is too large a footprint for the target board, consider using stand-offs, transition sockets or other extenders in the header connection socket to raise the header above the target.

**FIGURE 13: DIMENSIONS - AC244045**

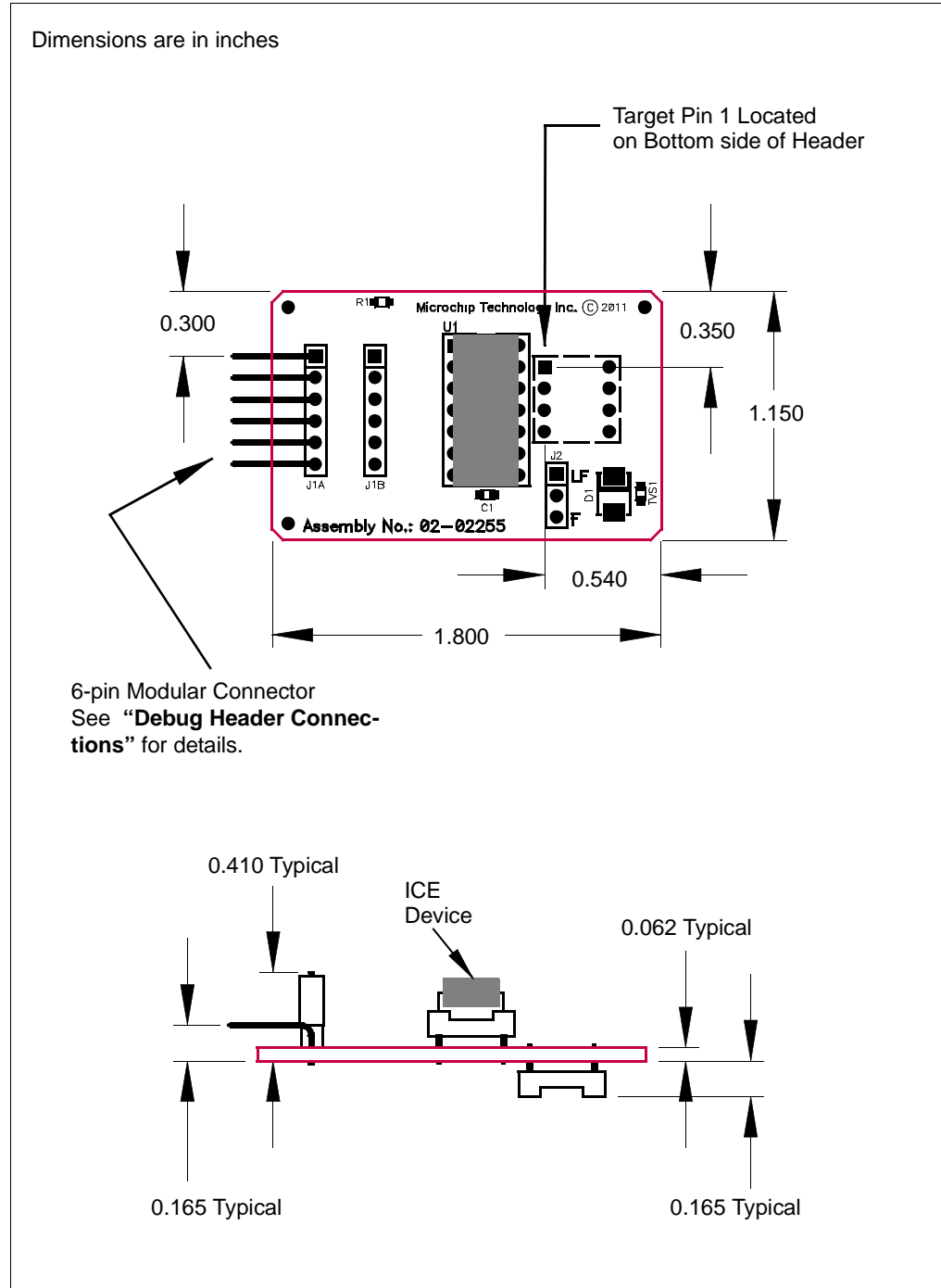

# Processor Extension Pak and Header Specification

---

## AC244051, AC244052

### Header Identification

The header AC number is used for ordering the header. However, this number is not on the debug header, as the board is often used for multiple headers by inserting different ICE/ICD devices. To identify this debug header, use the following information.

Header	ICE/ICD Device	Board Assembly Number
AC244051	PIC16F1509-ICE	02-02208
AC244052	PIC16LF1509-ICE	

### Header Setup and Operation

For this header, there are no jumpers/switches. MPLAB IDE/MPLAB X IDE will use its selected device to choose the correct device to emulate.

### Header Limitations

See the "Limitations" section in your debug tool online Help file for details.

# Required Debug Headers

## Header Dimensions

The figure below lists the dimensions for the debug header. Dimensions are design values in inches.

If the length and/or width of the debug header is too large a footprint for the target board, consider using stand-offs, transition sockets or other extenders in the header connection socket to raise the header above the target.

**FIGURE 14: DIMENSIONS - AC244051, AC244052**

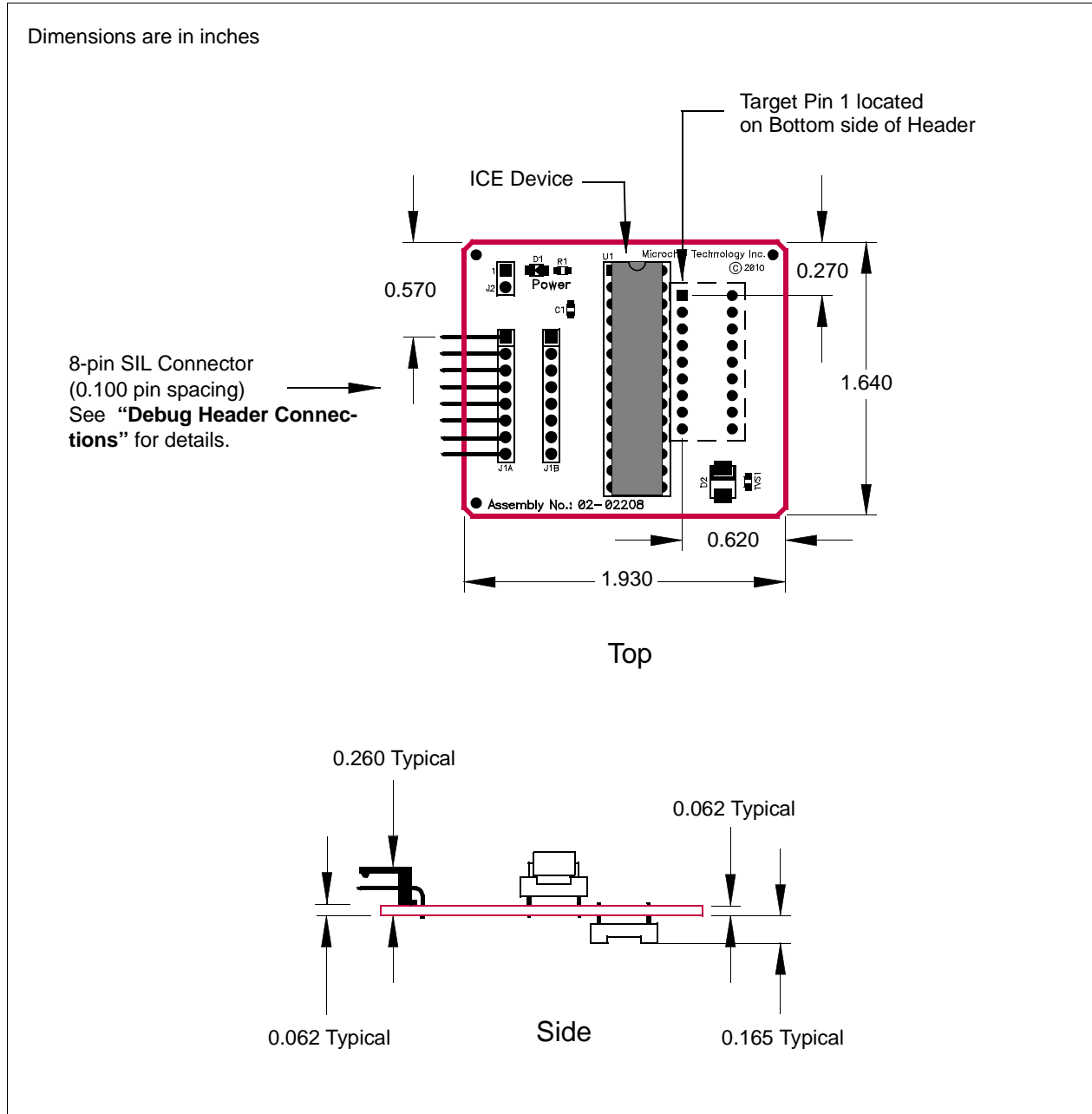

# Processor Extension Pak and Header Specification

---

NOTES:

## Optional Debug Headers

### INTRODUCTION

Devices that have built-in debug circuitry do not require a header to use debug tools. However, some pins and memory must be used to support the debug function. Special ICE/ICD versions offering additional pins, memory and emulator functions can be used to provide superior emulating/debugging capabilities.

**Note 1:** Currently available debug headers and their associated ICE/ICD devices are shown below by supported device. Header required for other devices.

**TABLE 1: OPTIONAL DEBUG HEADERS BY DEVICE**

Device	Pin Count	Header Part Number	ICE/ICD Device Used	VDD Max
PIC16F722 PIC16F723 PIC16F724 PIC16F726 PIC16F727	28 28 40/44 28 40/44	<a href="#">AC244026</a>	PIC16F727-ICE	5.5V
PIC16LF722 PIC16LF723 PIC16LF724 PIC16LF726 PIC16LF727	28 28 40/44 28 40/44	<a href="#">AC244027</a>	PIC16LF727-ICE	3.6V
PIC16F1454 PIC16F1455 PIC16F1458 PIC16F1459	14/16 14/16 20 20	<a href="#">AC244053</a>	PIC16F1459-ICE	5.5V
PIC16LF1454 PIC16LF1455 PIC16LF1458 PIC16LF1459	14/16 14/16 20 20	<a href="#">AC244054</a>	PIC16LF1459-ICE	3.6V
PIC16F1508 <sup>(1)</sup> PIC16F1509 <sup>(1)</sup>	20	<a href="#">AC244051</a>	PIC16F1509-ICE	5.5V
PIC16LF1508 <sup>(1)</sup> PIC16LF1509 <sup>(1)</sup>	20	<a href="#">AC244052</a>	PIC16LF1509-ICE	3.6V
PIC16F1826 PIC16F1827 PIC16F1847	18/20/28	<a href="#">AC244046</a>	PIC16F1847-ICE	3.6V
PIC12F1822 PIC12F1840 PIC16F1823 PIC16F1824 PIC16F1825 PIC16F1829	8/14/ 20	<a href="#">AC244043</a>	PIC16F1829-ICE	5.5V

**Note 1:** Header required for other devices.

**2:** VDDCORE Max

# Processor Extension Pak and Header Specification

**TABLE 1: OPTIONAL DEBUG HEADERS BY DEVICE (CONTINUED)**

Device	Pin Count	Header Part Number	ICE/ICD Device Used	VDD Max
PIC16LF1826 PIC16LF1827 PIC16LF1847	18/20/28	<a href="#">AC244047</a>	PIC16LF1847-ICE	3.6V
PIC12F1822 PIC12F1840 PIC16F1823 PIC16F1824 PIC16F1825 PIC16F1829	8/14/ 20	<a href="#">AC244044</a>	PIC16LF1829-ICE	3.6V
PIC16F1933 PIC16F1934 PIC16F1936 PIC16F1937 PIC16F1938 PIC16F1939	28 40/44 28 40/44 28 40/44	<a href="#">AC244035</a>	PIC16F1939-ICE	5.5V
PIC16LF1933 PIC16LF1934 PIC16LF1936 PIC16LF1937 PIC16LF1938 PIC16LF1939	28 40/44 28 40/44 28 40/44	<a href="#">AC244036</a>	PIC16LF1939-ICE	3.6V 2.75V <sup>(2)</sup>
PIC18F1230/1330	28	<a href="#">AC162078</a>	PIC18F1330-ICD	5.5V
PIC18F13K22 PIC18F14K22	20	<a href="#">AC244033</a>	PIC18F14K22-ICE	5.5V
PIC18LF13K22 PIC18LF14K22	20	<a href="#">AC244034</a>	PIC18LF14K22-ICE	3.6V 2.75V <sup>(2)</sup>
PIC18F24J10 PIC18F25J10	28	<a href="#">AC162067</a>	PIC18F45J10-ICE	3.6V
PIC18LF24J10 PIC18LF25J10				3.6V 2.75V <sup>(2)</sup>
PIC18F44J10 PIC18F45J10	40			3.6V
PIC18LF44J10 PIC18LF45J10				3.6V 2.75V <sup>(2)</sup>
PIC18F44J10 PIC18F45J10	44	<a href="#">AC162074</a>	PIC18F45J10-ICE	3.6V
PIC18LF44J10 PIC18LF45J10				3.6V 2.75V <sup>(2)</sup>

**Note 1:** Header required for other devices.

**2:** VDDCORE Max

# Optional Debug Headers

**TABLE 1: OPTIONAL DEBUG HEADERS BY DEVICE (CONTINUED)**

Device	Pin Count	Header Part Number	ICE/ICD Device Used	VDD Max
PIC18F63J11 PIC18F63J90 PIC18F64J11 PIC18F64J16 PIC18F64J90 PIC18F64J95 PIC18F65J11 PIC18F65J90	64	<a href="#">AC162079</a>	PIC18F85J90-ICE	3.6V
PIC18F83J11 PIC18F83J90 PIC18F84J11 PIC18F84J16 PIC18F84J90 PIC18F84J95 PIC18F85J11 PIC18F85J90	80			
PIC18F65J10 PIC18F65J15 PIC18F66J10 PIC18F66J15 PIC18F67J10	64	<a href="#">AC162062</a>	PIC18F87J10-ICE	3.6V
PIC18F85J10 PIC18F85J15 PIC18F86J10 PIC18F86J15 PIC18F87J10	80			
PIC18F65J16 PIC18F66J11 PIC18F66J16 PIC18F67J11	64	<a href="#">AC162091</a>	PIC18F87J11-ICE	3.6V
PIC18F85J16 PIC18F86J11 PIC18F86J16 PIC18F87J11	80			
PIC18F65J50 PIC18F65J55 PIC18F66J50 PIC18F66J55 PIC18F67J50	64	<a href="#">AC162087</a>	PIC18F87J50-ICE	3.6V
PIC18F85J50 PIC18F85J55 PIC18F86J50 PIC18F86J55 PIC18F87J50	80			

**Note 1:** Header required for other devices.

**2:** VDDCORE Max

# Processor Extension Pak and Header Specification

**TABLE 1: OPTIONAL DEBUG HEADERS BY DEVICE (CONTINUED)**

Device	Pin Count	Header Part Number	ICE/ICD Device Used	VDD Max
PIC18F66J60 PIC18F66J65 PIC18F67J60	64	<a href="#">AC162064</a>	PIC18F97J60-ICE	3.6V
PIC18F86J60 PIC18F86J65 PIC18F87J60	80			
PIC18F96J60 PIC18F96J65 PIC18F97J60	100			
PIC24F08KA101 <sup>(1)</sup> PIC24F08KA102 <sup>(1)</sup> PIC24F16KA101 <sup>(1)</sup> PIC24F16KA102 <sup>(1)</sup>	20 20/28 20 20/28	<a href="#">AC244028</a>	PIC24F16KA102-ICE	3.6V
PIC24FJ16GA002 PIC24FJ32GA002 PIC24FJ48GA002 PIC24FJ64GA002	28	<a href="#">AC162088</a>	PIC24FJ64GA004-ICE	3.6V
PIC24FJ16GA004 PIC24FJ32GA004 PIC24FJ48GA004 PIC24FJ64GA004	44	<a href="#">AC162094</a>		
PIC24FJ64GA006 PIC24FJ64GA008 PIC24FJ64GA010	64 80 100	<a href="#">AC162065</a> or <a href="#">AC244022</a>	PIC24FJ128GA010-ICE	3.6V
PIC24FJ96GA006 PIC24FJ96GA008 PIC24FJ96GA010	64 80 100			
PIC24FJ128GA006 PIC24FJ128GA008 PIC24FJ128GA010	64 80 100			

**Note 1:** Header required for other devices.

**2:** VDDCORE Max



## AC162062, AC162079, AC162087, AC162091

### Header Identification

The header AC number is used for ordering the header. However, this number is not on the debug header, as the board is often used for multiple headers by inserting different ICE/ICD devices. To identify these debug headers, use the following information.

Header	ICE/ICD Device	Board Assembly Number
AC162062	PIC18F87J10-ICE	02-01830
AC162079	PIC18F85J90-ICE	
AC162087	PIC18F87J50-ICE	
AC162091	PIC18F87J11-ICE	

### Header Setup and Operation – AC162062

For this header, there are no jumpers/switches. MPLAB IDE/MPLAB X IDE will use its selected device to choose the correct device to emulate.

Test points are available on this header to check the VDD, VDDCORE, and ground.

**CAUTION**



**This header cannot be plugged directly into the PICDEM™ HPC Explorer Board!**

**Device damage will result.**

The PICDEM™ HPC Explorer Board is 5V, whereas the ICD device on the header is 3.6V max. Therefore, modification to the demo board is necessary before the header can be used.

1. Switch S3 should be set to ICE.
2. Jumper J2 must be connected as shown in Figure 1 to modify the operating voltage. See demo board documentation for more information.

**FIGURE 1: DEMO BOARD J2 CONNECTIONS**

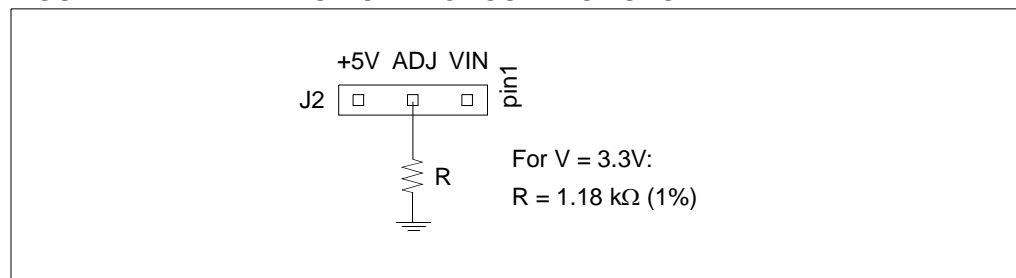

### Header Setup and Operation – AC162079, AC162087, AC162091

For these headers, there are no jumpers/switches. MPLAB IDE/MPLAB X IDE will use its selected device to choose the correct device to emulate.

Test points are available on this header to check the VDD, VDDCORE, and ground.

### Header Limitations

See the “Limitations” section in your debug tool online Help file for details.

# Processor Extension Pak and Header Specification

## Header Dimensions

The figure below lists the dimensions for the debug header. Dimensions are design values in inches.

If the length and/or width of the debug header is too large a footprint for the target board, consider using stand-offs, transition sockets or other extenders in the header connection socket to raise the header above the target.

**FIGURE 2: DIMENSIONS – AC162062, AC162079, AC162087, AC162091**

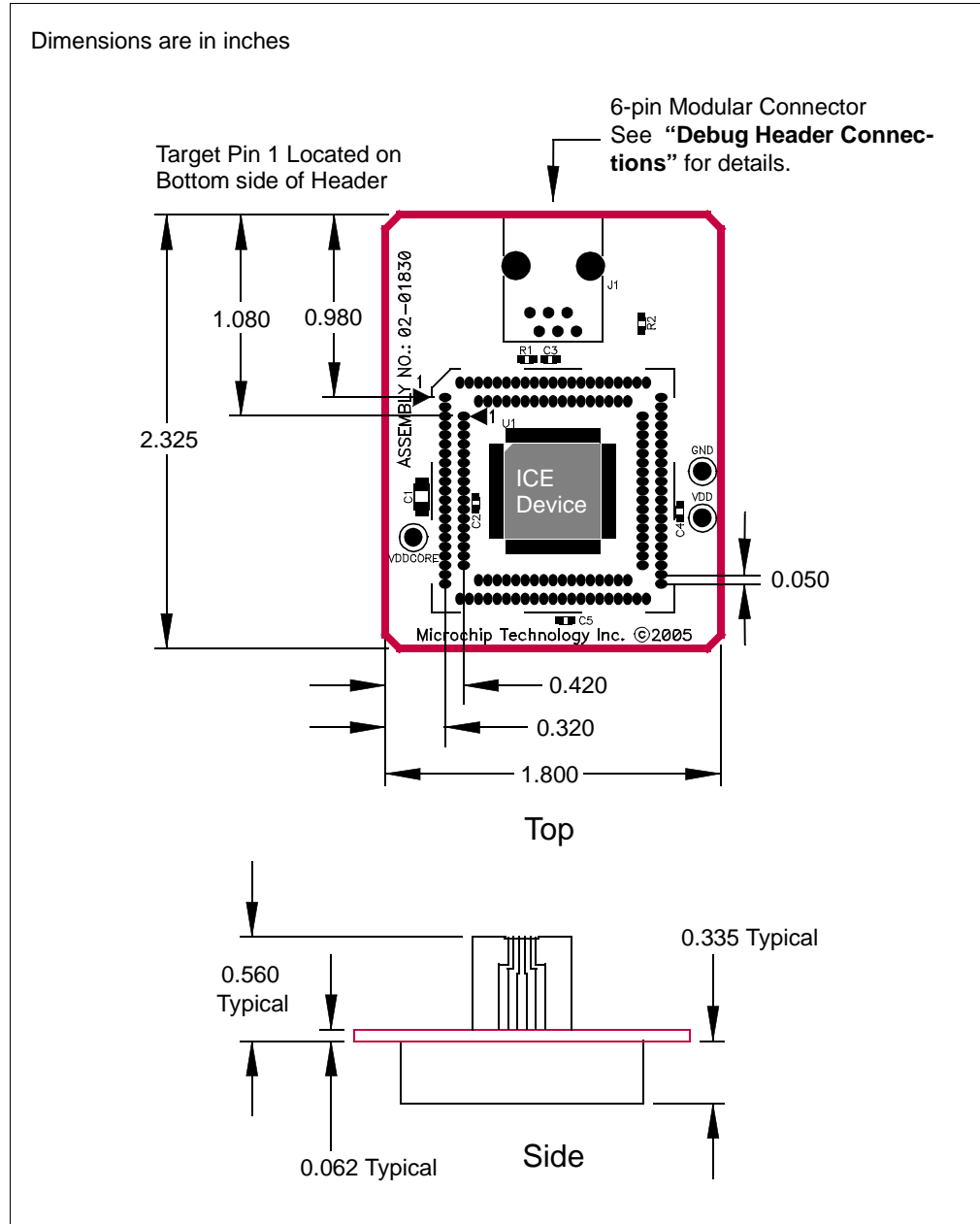

## AC162064

### Header Identification

The header AC number is used for ordering the header. However, this number is not on the debug header, as the board is often used for multiple headers by inserting different ICE/ICD devices. To identify this debug header, use the following information.

Header	ICE/ICD Device	Board Assembly Number
AC162064	PIC18F97J60-ICE	02-01853

### Header Setup and Operation

For this header, there are no jumpers/switches. MPLAB IDE/MPLAB X IDE will use its selected device to choose the correct device to emulate.

Test points are available on this header to check the following: VDD, VDDCORE and ground.

### Header Limitations

See the "Limitations" section in your debug tool online Help file for details.

# Processor Extension Pak and Header Specification

## Header Dimensions

The figure below lists the dimensions for the debug header. Dimensions are design values in inches.

If the length and/or width of the debug header is too large a footprint for the target board, consider using stand-offs, transition sockets or other extenders in the header connection socket to raise the header above the target.

**FIGURE 3: DIMENSIONS – AC162064**

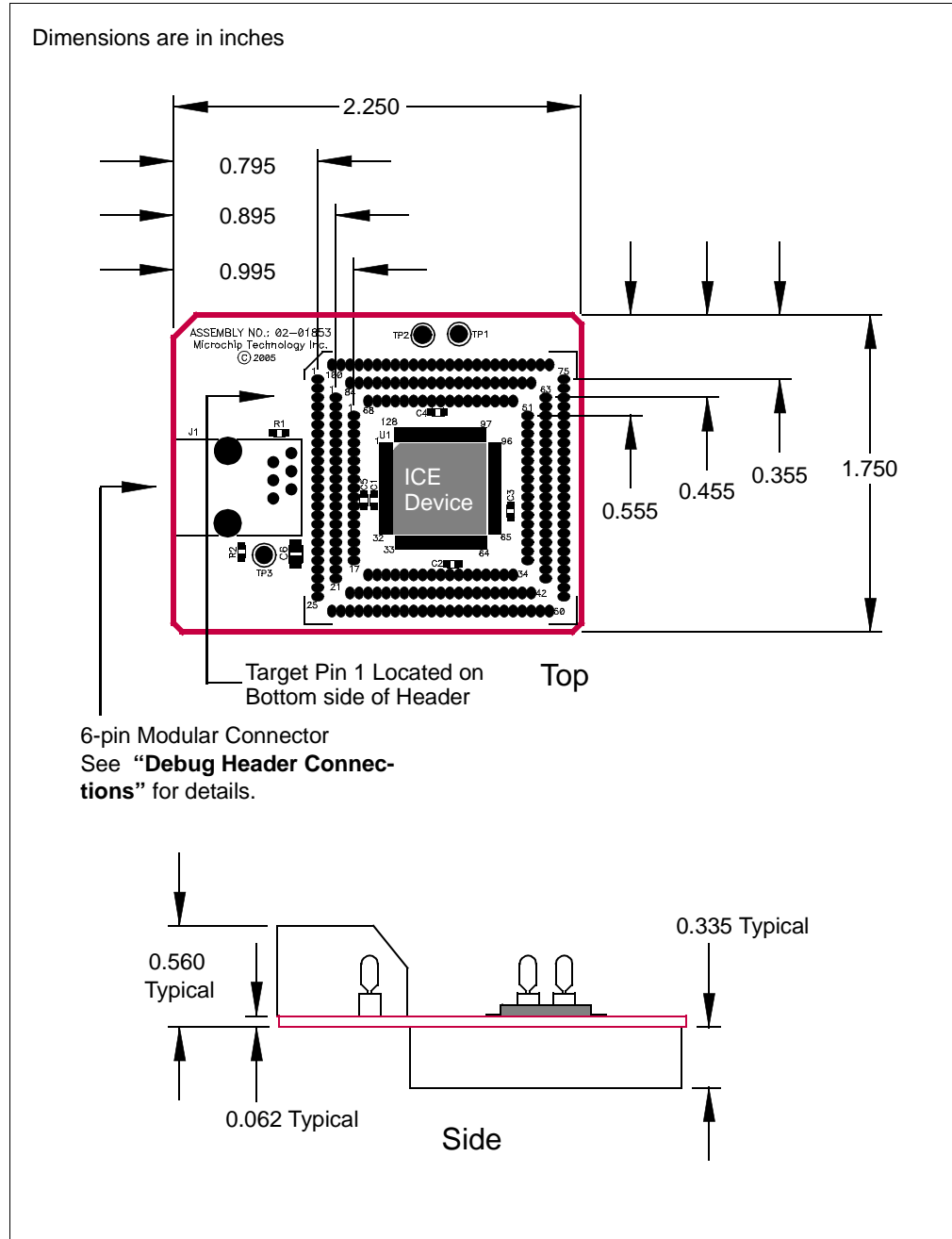

## AC162065, AC244022

### Header Identification

The header AC number is used for ordering the header. However, this number is not on the debug header, as the board is often used for multiple headers by inserting different ICE/ICD devices. To identify these debug headers, use the following information.

Header	ICE/ICD Device	Board Assembly Number
AC162065	PIC24FJ128GA010-ICE	02-01856
AC244022		02-01985

### Header Setup and Operation

For this header, there are no jumpers/switches. MPLAB IDE/MPLAB X IDE will use its selected device to choose the correct device to emulate.

Test points are available on this header to check the following: VDD, VDDCORE and ground.

### Header Limitations

See the "Limitations" section in your debug tool online Help file for details.

# Processor Extension Pak and Header Specification

## Header Dimensions

The figures below lists the dimensions for the debug headers. Dimensions are design values in inches.

For this device family, header AC162065 will be sold until depleted. Then only header AC244022 will remain as a Performance Pak.

If the length and/or width of the debug header is too large a footprint for the target board, consider using stand-offs, transition sockets or other extenders in the header connection socket to raise the header above the target.

**FIGURE 4: DIMENSIONS – AC162065**

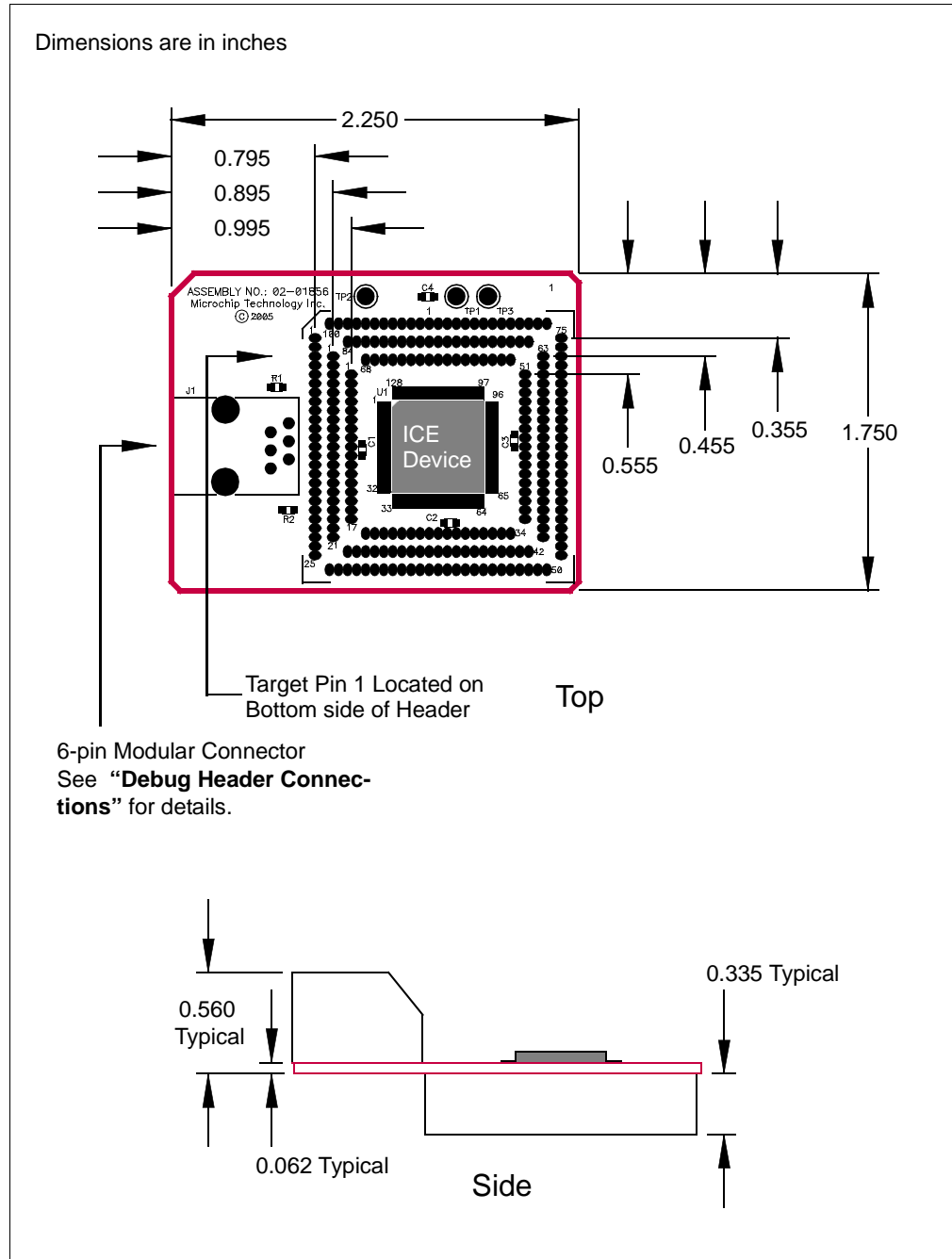

# Optional Debug Headers

**FIGURE 5: DIMENSIONS – AC244022**

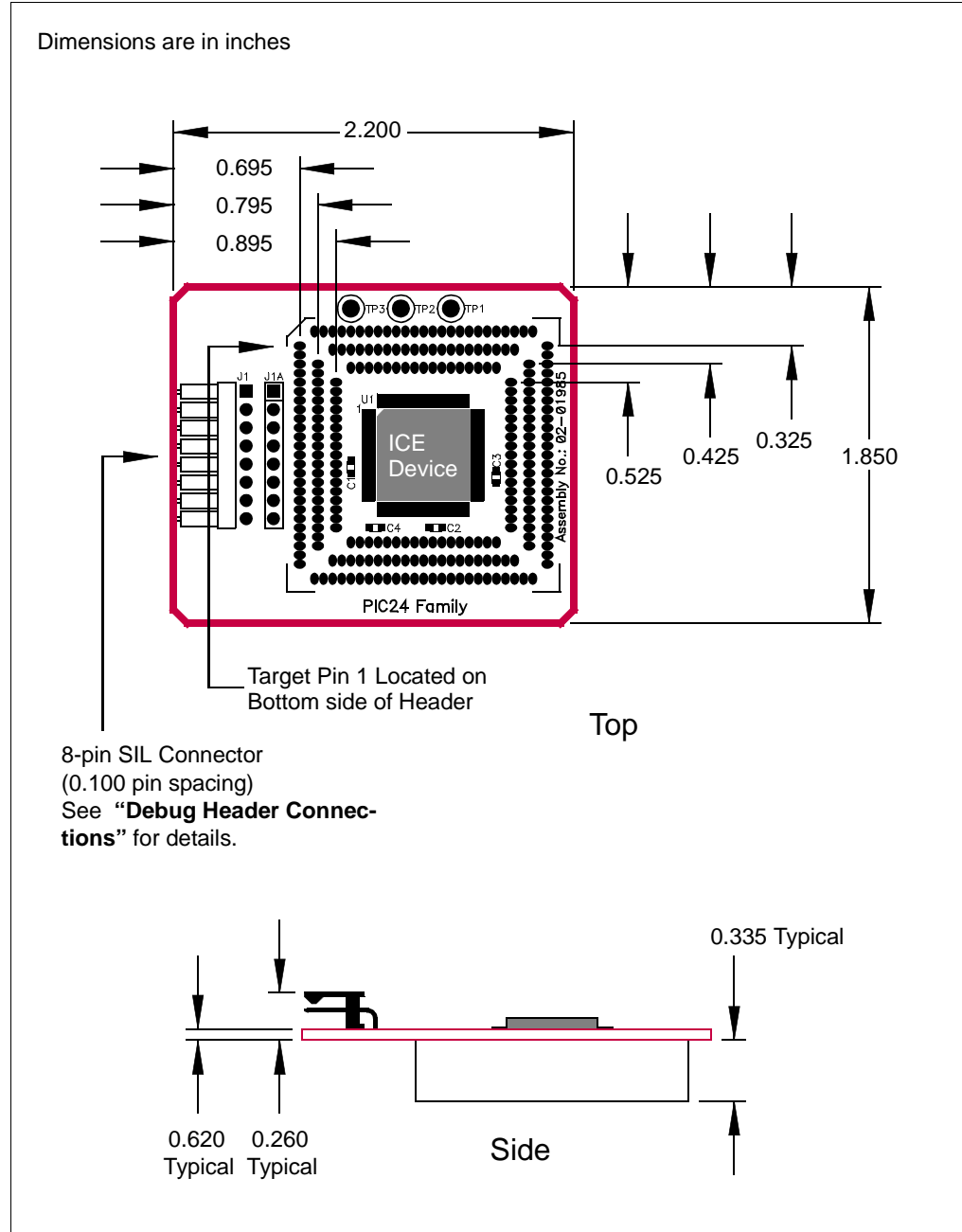

# Processor Extension Pak and Header Specification

---

## AC162067, AC162074

### Header Identification

The header AC number is used for ordering the header. However, this number is not on the debug header, as the board is often used for multiple headers by inserting different ICE/ICD devices. To identify these debug headers, use the following information.

Header	ICE/ICD Device	Board Assembly Number
AC162067	PIC18F45J10-ICE	02-01854
AC162074		02-01929

### Header Setup and Operation

For these headers, you will need to connect jumpers J2 and J3 to select between the LF and F versions of devices.

Device	Device Type	Jumper J2	Jumper J3	Function
PIC18LFXXJ10	LF	1-2	1-2	Disable voltage regulator*
PIC18FXXJ10	F	2-3	2-3	Enable voltage regulator

\* VDDCORE must be supplied externally.

### Header Limitations

See the "Limitations" section in your debug tool online Help file for details.



# Optional Debug Headers

## Header Dimensions

The figures below lists the dimensions for the debug headers. Dimensions are design values in inches.

If the length and/or width of the debug header is too large a footprint for the target board, consider using stand-offs, transition sockets or other extenders in the header connection socket to raise the header above the target.

**FIGURE 6: DIMENSIONS (28/40-PIN) – AC162067**

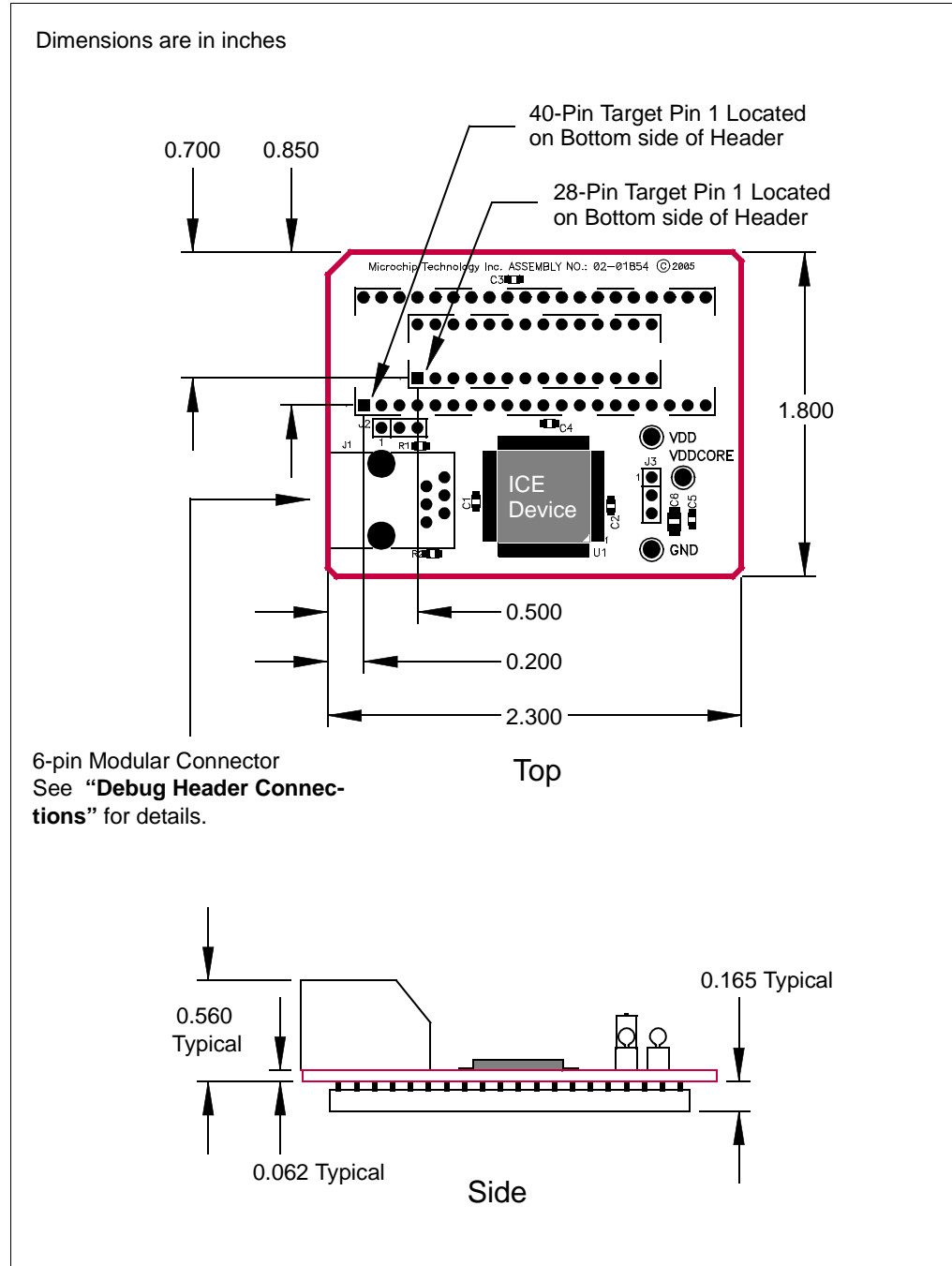

# Processor Extension Pak and Header Specification

FIGURE 7: DIMENSIONS (44-PIN) – AC162074

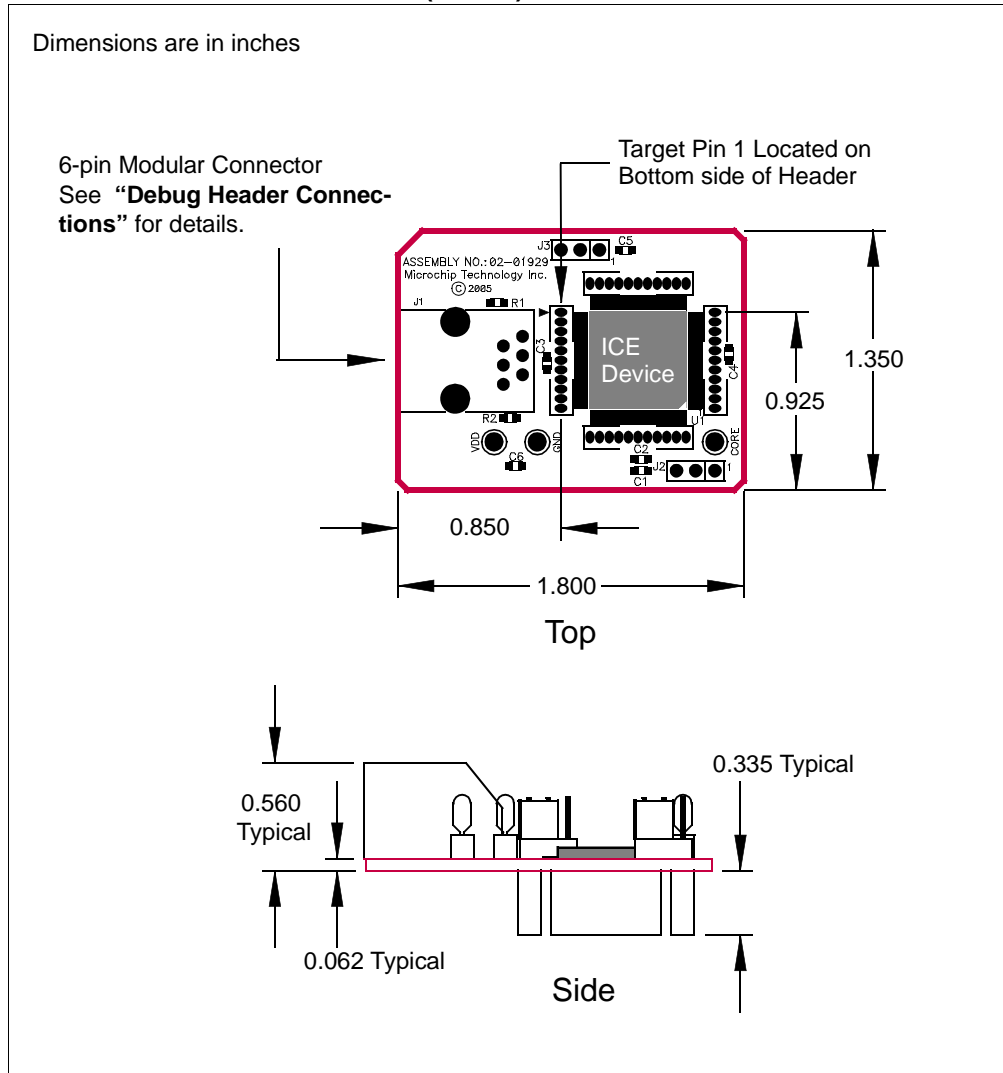

## AC162078

### Header Identification

The header AC number is used for ordering the header. However, this number is not on the debug header, as the board is often used for multiple headers by inserting different ICE/ICD devices. To identify this debug header, use the following information.

Header	ICE/ICD Device	Board Assembly Number
AC162078	PIC18F1330-ICD	02-01896

### Header Setup and Operation

This debug header can be used with the following targets:

1. Customer target board for PIC18F1230/1330 devices. The target board should have an 18-pin DIP socket to connect to the 18-pin DIP socket on the debug header.
2. PICDEM MC motor control demo board. Use the 28-pin DIP socket on both boards to mount the debug header on to the PICDEM MC board.
3. PICDEM MC LV motor control demo board. Use the 28-pin DIP socket on both boards to mount the debug header on to the PICDEM MC LV board.

The following sections detail the configuration of the jumpers on the debug header for use with the above mentioned boards.

#### CUSTOMER TARGET BOARD

The default configuration is to remove all jumpers.

S1 is not populated and should not be used.

After the debug header is set up, do the following:

1. Connect the header to the target board.
2. Power the target board. You should see the red LED on the debug header turn on.
3. Connect the debug tool to the debug header.
4. Use MPLAB IDE/MPLAB X IDE and the debug tool to develop your application.

#### PICDEM MC/MC LV MOTOR CONTROL DEMO BOARDS

To run a BLDC motor on the PICDEM MC board or PICDEM MC LV board using the supplied firmware, use the following jumper setup:

Jumper	Jumper Setting	Jumper	Jumper Setting
J1	2-3	JP1	Open
J2	2-3		
J3	2-3	JP2	Open
J5	2-3		
J6	1-2	JP3	Open
J7	1-2		

S1 is not populated and should not be used.

# Processor Extension Pak and Header Specification

---

After the debug header is set up, do the following:

1. Connect the header to the PICDEM MC/MC LV target board.
2. Power the target board. You should see the red LED on the debug header turn on.
3. Connect the debug tool to the debug header.
4. Program the part with the demo code.
5. Run the program.
6. Press and release switch S2 on the target board to toggle the direction of the motor's rotation.
7. Press and release switch S1 on the target board to toggle between running and stopping the motor.
8. If the motor stops while reversing from a high speed, there could be an overcurrent condition detected by the system. Reset the system to run the program again.

## Header Limitations

See the "Limitations" section in your debug tool online Help file for details.

## Header Dimensions

The figure below lists the dimensions for the debug header. Dimensions are design values in inches.

If the length and/or width of the debug header is too large a footprint for the target board, consider using stand-offs, transition sockets or other extenders in the header connection socket to raise the header above the target.

**FIGURE 8: DIMENSIONS – AC162078**

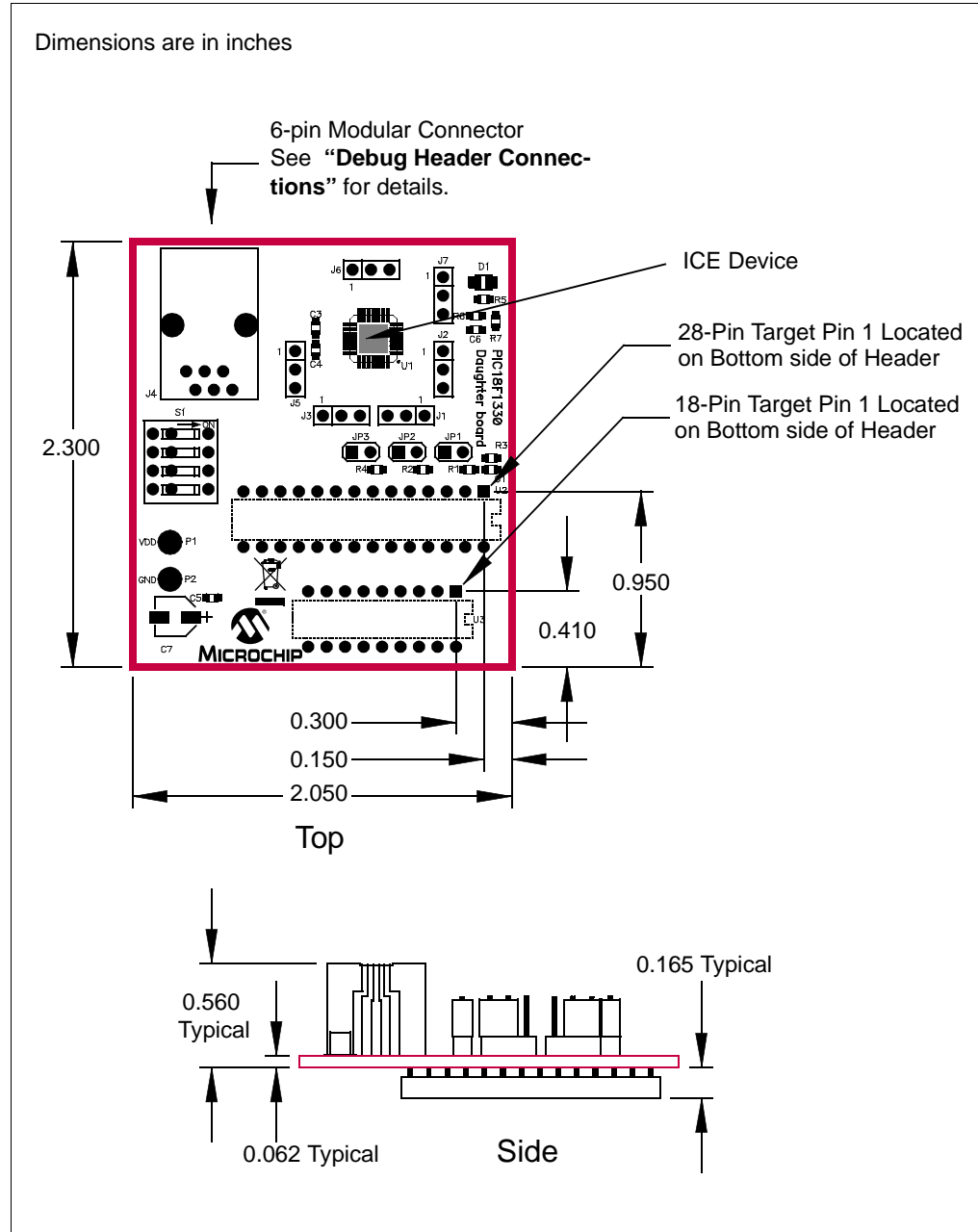

# Processor Extension Pak and Header Specification

---

## AC162088, AC162094

### Header Identification

The header AC number is used for ordering the header. However, this number is not on the debug header, as the board is often used for multiple headers by inserting different ICE/ICD devices. To identify this debug header, use the following information.

Header	ICE/ICD Device	Board Assembly Number
AC162088	PIC24FJ64GA004-ICE	02-01979
AC162094		02-01982

### Header Setup and Operation

Both 28-pin and 44-pin device headers have jumpers related to the enabling or disabling of the on-chip 2.5 volt voltage regulator. Please see the section entitled “On-Chip Voltage Regulator” in the “*dsPIC33F Family Reference Manual*” (DS70165) for more details.

Jumper J2	Function
1-2	Disable voltage regulator
2-3	Enable voltage regulator
No connection	DISVREG controlled by target

Test points are available on this header to check the following:

Test Point	Color	Signal	Test Point	Color	Signal
TP1	Black	Ground	TP5	White	DISVREG
TP2	Red	VDD	TP6	White	PGC
TP3	Black	AVss	TP7	White	PGD
TP4	Red	AVDD	TP8	Yellow	$\overline{\text{ICRST}}$

### Header Limitations

See the “Limitations” section in your debug tool online Help file for details.

# Optional Debug Headers

## Header Dimensions

The figures below list the dimensions for the debug headers. Dimensions are design values in inches.

If the length and/or width of the debug header is too large a footprint for the target board, consider using stand-offs, transition sockets or other extenders in the header connection socket to raise the header above the target.

**FIGURE 9: DIMENSIONS (28 PIN) – AC162088**

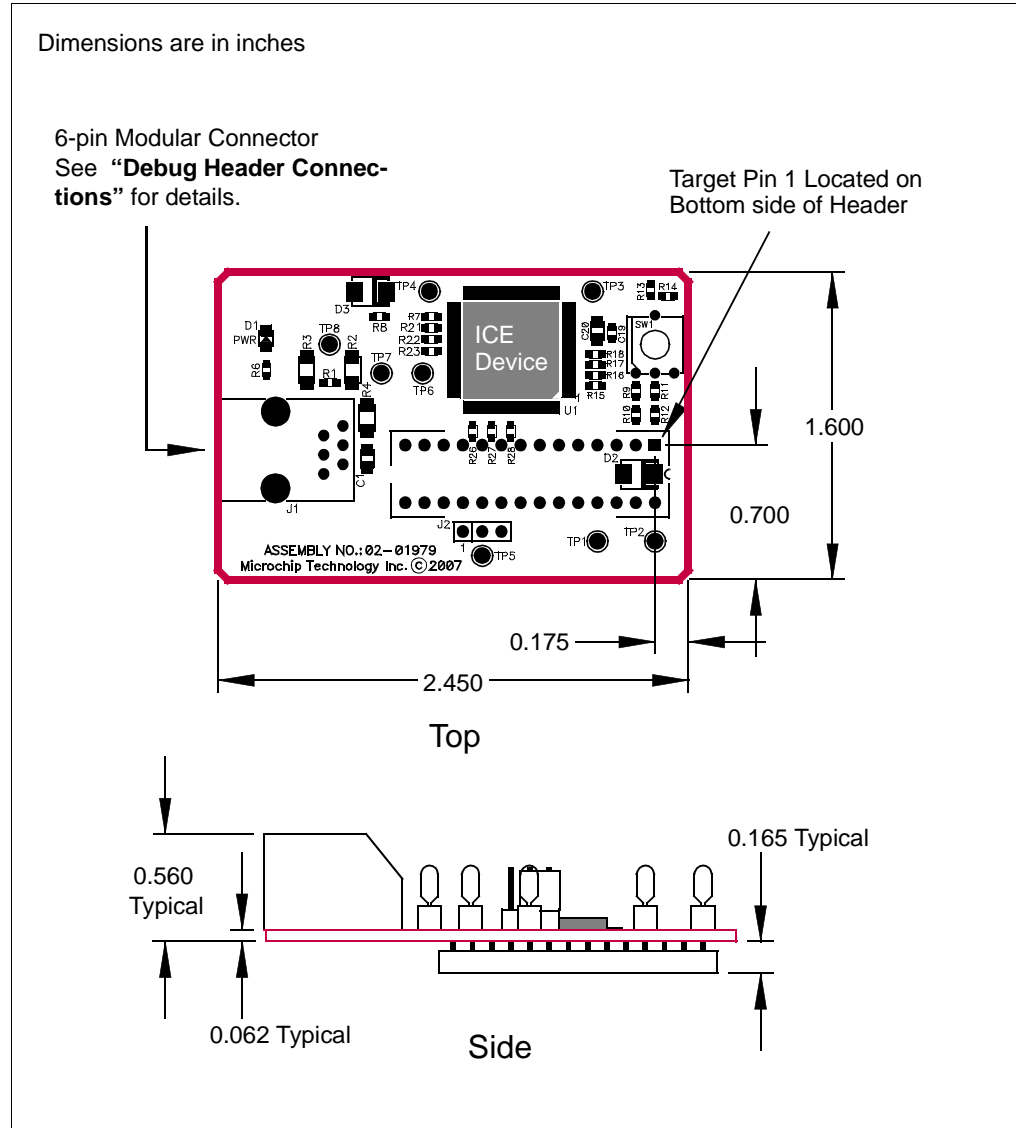

# Processor Extension Pak and Header Specification

**FIGURE 10: DIMENSIONS (44 PIN) – AC162094**

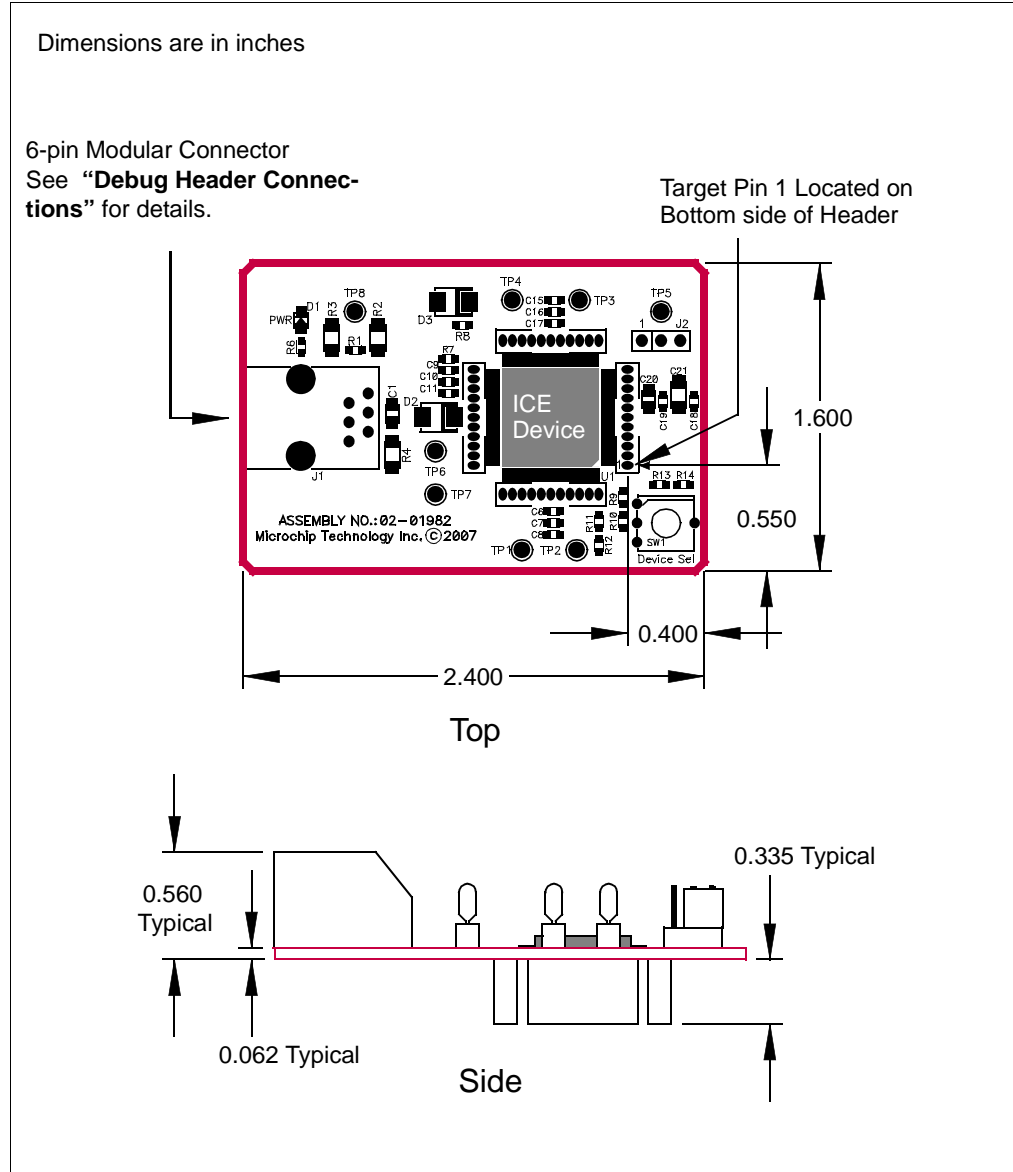



## AC244026, AC244027

### Header Identification

The header AC number is used for ordering the header. However, this number is not on the debug header, as the board is often used for multiple headers by inserting different ICE/ICD devices. To identify this debug header, use the following information.

Header	ICE/ICD Device	Board Assembly Number
AC244026	PIC16F727-ICE	02-02105
AC244027	PIC16LF727-ICE	

### Header Setup and Operation - AC244026

This Processor Extension Pak provides extra debugging capability not available on PIC16F727 production devices:

- 3 Address / Data breakpoints (1 Address only breakpoint on production devices)
- Data capture (Real Time Data Streaming)
- No user Flash resources needed for debugging
- No user RAM resources needed for debugging
- No user pins required

This header has jumpers available for MCLR pull-up and power LED control.

Jumper	Setting	Function
J2	Open	Disable weak ICE $\overline{\text{MCLR}}$ pull-up resistor.
	Short	Enable weak ICE $\overline{\text{MCLR}}$ pull-up resistor. This option keeps the target program running even after the tool has been disconnected from the header, i.e., the pin will not float high.
J3	Open	Disable power LED indicator. This option saves power.
	Short	Enable power LED indicator.

Additionally, this header has jumpers related to the LDO voltage regulator. Depending on the device pin used for this function, you would use either J4 (RA0), J5 (RA5) or J6 (RA6) for Vcap selection. For details on the voltage regulator, see the *PIC16F72X/PIC16LF72X Data Sheet (DS41341)*.

Jumper	Setting	Function
J4, J5, or J6	Open	Use only target capacitance for Vcap. This is the standard configuration.
	Short	Use both on-board and target capacitance for Vcap. This option is to provide extra margin for the voltage regulator stability/regulation in cases where there is a long lead length between the emulation header Vcap pin and the target Vcap pin. (As examples, when using long-pin DIP transition sockets or certain QFN transition sockets.)

# Processor Extension Pak and Header Specification

Test points are available on this header to check the following:

Test Point	Signal	Test Point	Signal	Pin	Jumper
TP1	V <sub>SS</sub>	TP6	V <sub>cap</sub>	RA0	J4
TP2	V <sub>DD</sub>	TP7	V <sub>cap</sub>	RA5	J5
TP3	$\overline{\text{ICD Enable}}$	TP8	V <sub>cap</sub>	RA6	J6
TP4	V <sub>DD</sub>				
TP5	V <sub>SS</sub>				

## Header Setup and Operation - AC244027

This Processor Extension Pak provides extra debugging capability not available on PIC16LF727 production devices:

- 3 Address / Data breakpoints (1 Address only breakpoint on production devices)
- Data capture (Real Time Data Streaming)
- No user Flash resources needed for debugging
- No user RAM resources needed for debugging
- No user pins required

This header has jumpers available for MCLR pull-up and power LED control.

Jumper	Setting	Function
J2	Open	Disable weak ICE $\overline{\text{MCLR}}$ pull-up resistor.
	Short	Enable weak ICE $\overline{\text{MCLR}}$ pull-up resistor. This option keeps the target program running even after the tool has been disconnected from the header, i.e., the pin will not float high.
J3	Open	Disable power LED indicator. This option saves power.
	Short	Enable power LED indicator.

Test points are available on this header to check the following:

Test Point	Signal	Test Point	Signal
TP1	V <sub>SS</sub>	TP4	V <sub>DD</sub>
TP2	V <sub>DD</sub>	TP5	V <sub>SS</sub>
TP3	$\overline{\text{ICD Enable}}$		

## Header Limitations

See the “Limitations” section in your debug tool online Help file for details.

## Header Dimensions

The figures below list the dimensions for the debug headers. Dimensions are design values in inches.

If the length and/or width of the debug header is too large a footprint for the target board, consider using stand-offs, transition sockets or other extenders in the header connection socket to raise the header above the target.



# Processor Extension Pak and Header Specification

---

## AC244033, AC244034

### Header Identification

The header AC number is used for ordering the header. However, this number is not on the debug header, as the board is often used for multiple headers by inserting different ICE/ICD devices. To identify this debug header, use the following information.

Header	ICE/ICD Device	Board Assembly Number
AC244033	PIC18F14K22-ICE	02-02031
AC244034	PIC18LF14K22-ICE	

### Header Setup and Operation

For this header, there are no jumpers/switches. MPLAB IDE/MPLAB X IDE will use its selected device to choose the correct device to emulate.

### Header Limitations

See the "Limitations" section in your debug tool online Help file for details.

# Optional Debug Headers

## Header Dimensions

The figures below list the dimensions for the debug headers. Dimensions are design values in inches.

If the length and/or width of the debug header is too large a footprint for the target board, consider using stand-offs, transition sockets or other extenders in the header connection socket to raise the header above the target.

**FIGURE 12: DIMENSIONS (20 PIN) – AC244033, AC244034**

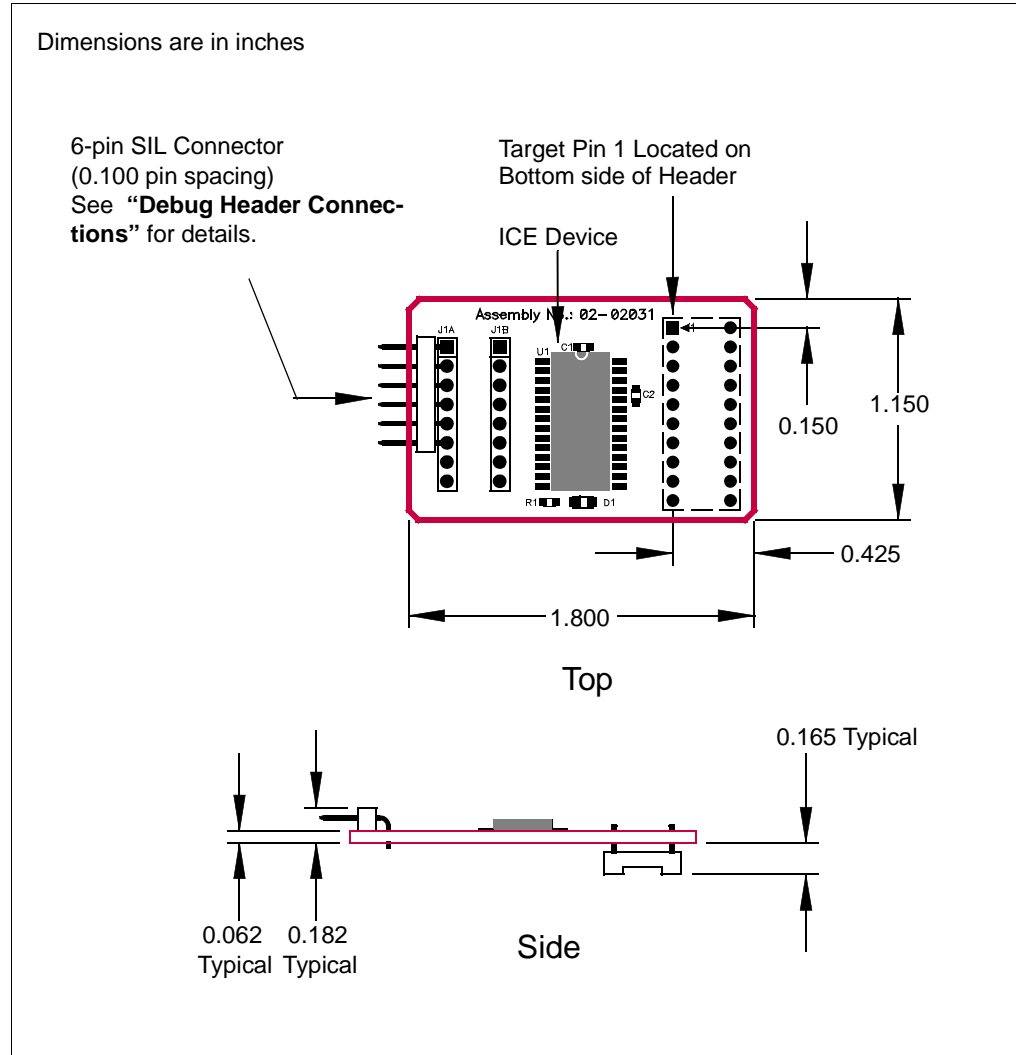

# Processor Extension Pak and Header Specification

---

## AC244035, AC244036

### Header Identification

The header AC number is used for ordering the header. However, this number is not on the debug header, as the board is often used for multiple headers by inserting different ICE/ICD devices. To identify this debug header, use the following information.

Header	ICE/ICD Device	Board Assembly Number
AC244035	PIC16F1939-ICE	02-02105
AC244036	PIC16LF1939-ICE	

### Header Setup and Operation

For this header, you will need to set up the jumpers below.

Jumper	Setting	Function
J2	Open	Disable weak ICE/MCLR pull-up resistor
	Short	Enable weak ICE/MCLR pull-up resistor
J3	Open	Disable power LED indicator
	Short	Enable power LED indicator
J4	Open	Use only target capacitance for VCAP (on RA0 pin)
	Short	Use both on-board and target capacitance for VCAP (on RA0 pin)
J5	Open	Use only target capacitance for VCAP (on RA5 pin)
	Short	Use both on-board and target capacitance for VCAP (on RA5 pin)
J6	Open	Use only target capacitance for VCAP (on RA6 pin)
	Short	Use both on-board and target capacitance for VCAP (on RA6 pin)

### Header Limitations

See the "Limitations" section in your debug tool online Help file for details.

# Optional Debug Headers

## Header Dimensions

The figure below lists the dimensions for the debug header. Dimensions are design values in inches.

If the length and/or width of the debug header is too large a footprint for the target board, consider using stand-offs, transition sockets or other extenders in the header connection socket to raise the header above the target.

**FIGURE 13: DIMENSIONS - AC244035, AC244036**

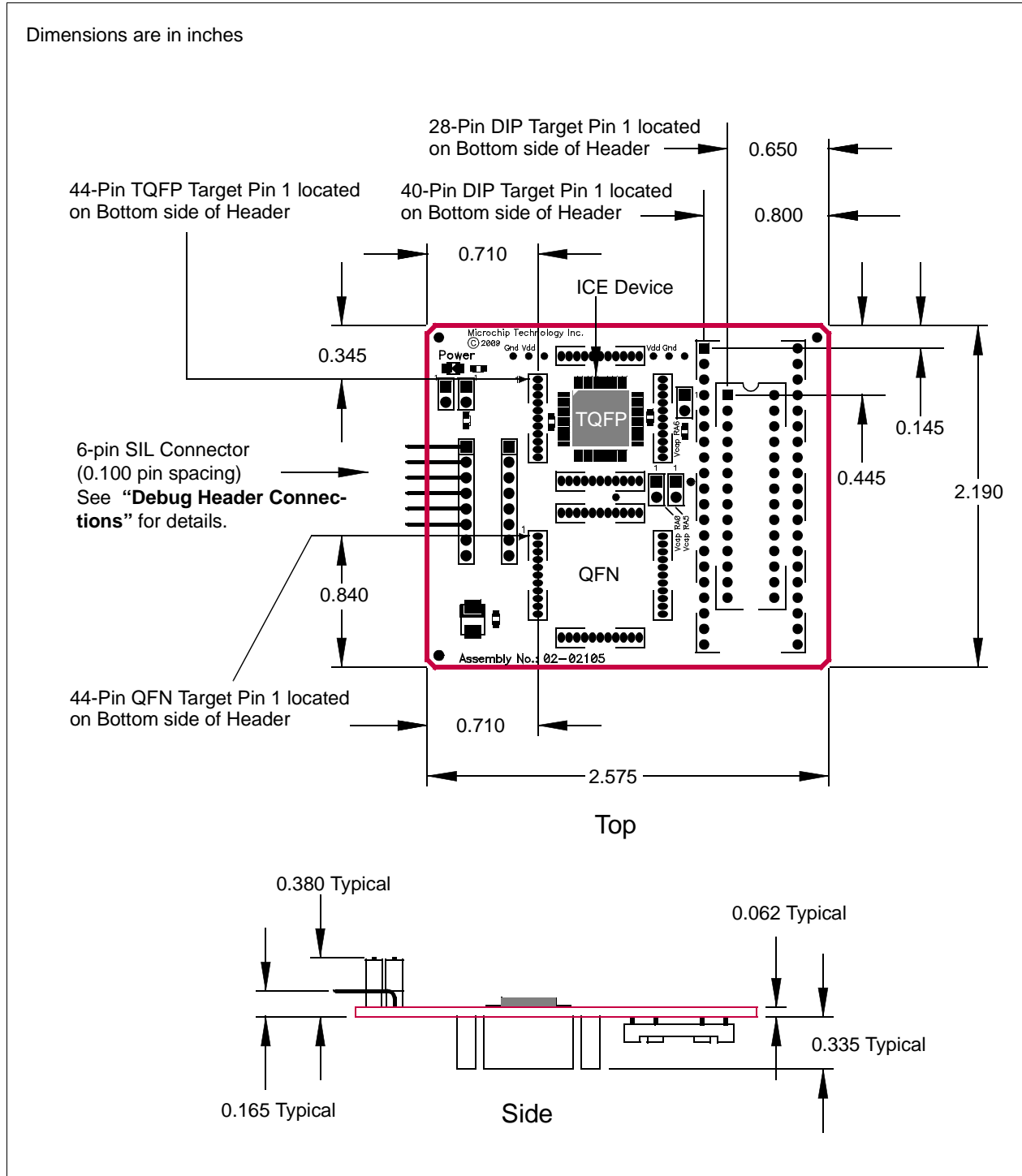

# Processor Extension Pak and Header Specification

---

## AC244043, AC244044

### Header Identification

The header AC number is used for ordering the header. However, this number is not on the debug header, as the board is often used for multiple headers by inserting different ICE/ICD devices. To identify this debug header, use the following information.

Header	ICE/ICD Device	Board Assembly Number
AC244043	PIC16F1829-ICE	02-02208
AC244044	PIC16LF1829-ICE	

### Header Setup and Operation

For this header, there are no jumpers/switches. MPLAB IDE/MPLAB X IDE will use its selected device to choose the correct device to emulate.

### Header Limitations

See the "Limitations" section in your debug tool online Help file for details.



# Optional Debug Headers

## Header Dimensions

The figure below lists the dimensions for the debug header. Dimensions are design values in inches.

If the length and/or width of the debug header is too large a footprint for the target board, consider using stand-offs, transition sockets or other extenders in the header connection socket to raise the header above the target.

**FIGURE 14: DIMENSIONS - AC244043, AC244044**

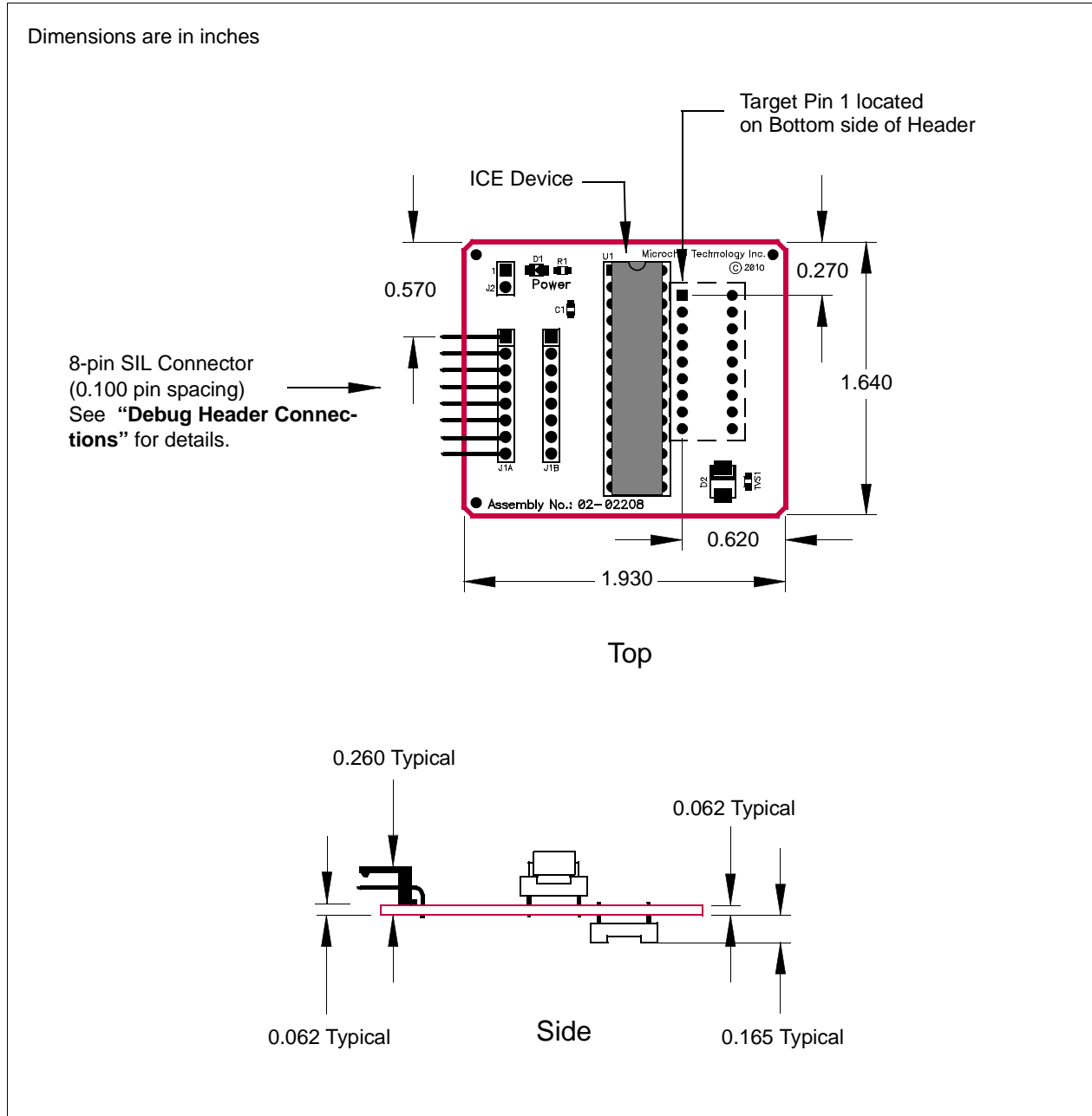

# Processor Extension Pak and Header Specification

---

## AC244046, AC244047

### Header Identification

The header AC number is used for ordering the header. However, this number is not on the debug header, as the board is often used for multiple headers by inserting different ICE/ICD devices. To identify this debug header, use the following information.

Header	ICE/ICD Device	Board Assembly Number
AC244046	PIC16F1847-ICE	02-02258
AC244047	PIC16LF1847-ICE	

### Header Setup and Operation

For this header, there are no jumpers/switches. MPLAB IDE/MPLAB X IDE will use its selected device to choose the correct device to emulate.

### Header Limitations

See the "Limitations" section in your debug tool online Help file for details.

# Optional Debug Headers

## Header Dimensions

The figure below lists the dimensions for the debug header. Dimensions are design values in inches.

If the length and/or width of the debug header is too large a footprint for the target board, consider using stand-offs, transition sockets or other extenders in the header connection socket to raise the header above the target.

**FIGURE 15: DIMENSIONS - AC244046, AC244047**

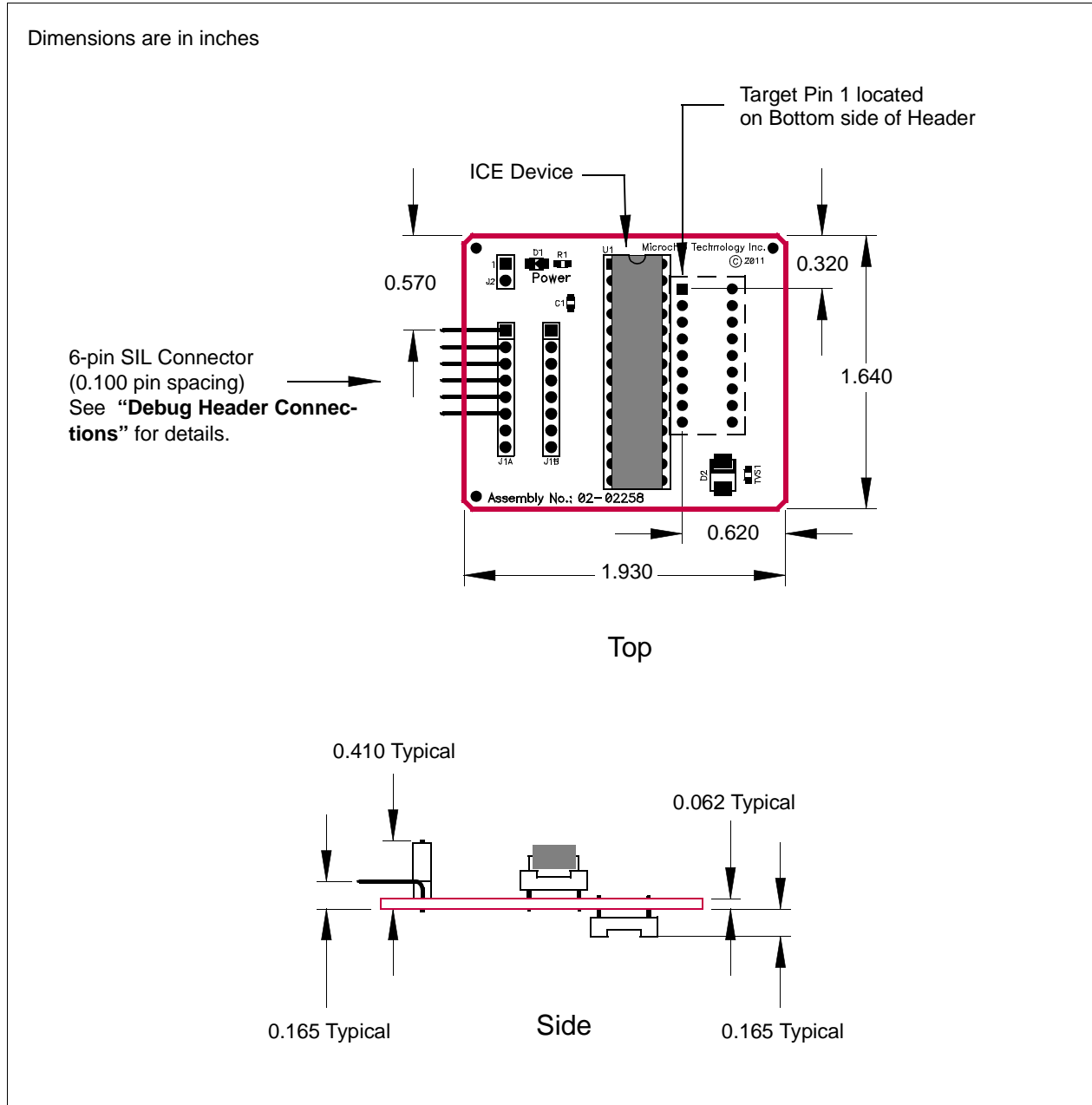

# Processor Extension Pak and Header Specification

---

## AC244053, AC244054

### Header Identification

The header AC number is used for ordering the header. However, this number is not on the debug header, as the board is often used for multiple headers by inserting different ICE/ICD devices. To identify these debug headers, use the following information.

Header	ICE/ICD Device	Board Assembly Number
AC244053	PIC16F1459-ICE	02-02031
AC244054	PIC16LF1459-ICE	

### Header Setup and Operation

For this header, there are no jumpers/switches. MPLAB IDE/MPLAB X IDE will use its selected device to choose the correct device to emulate.

### Header Limitations

See the "Limitations" section in your debug tool online Help file for details.

# Optional Debug Headers

## Header Dimensions

The figure below lists the dimensions for the debug header. Dimensions are design values in inches.

If the length and/or width of the debug header is too large a footprint for the target board, consider using stand-offs, transition sockets or other extenders in the header connection socket to raise the header above the target.

**FIGURE 16: DIMENSIONS – AC244053, AC224054**

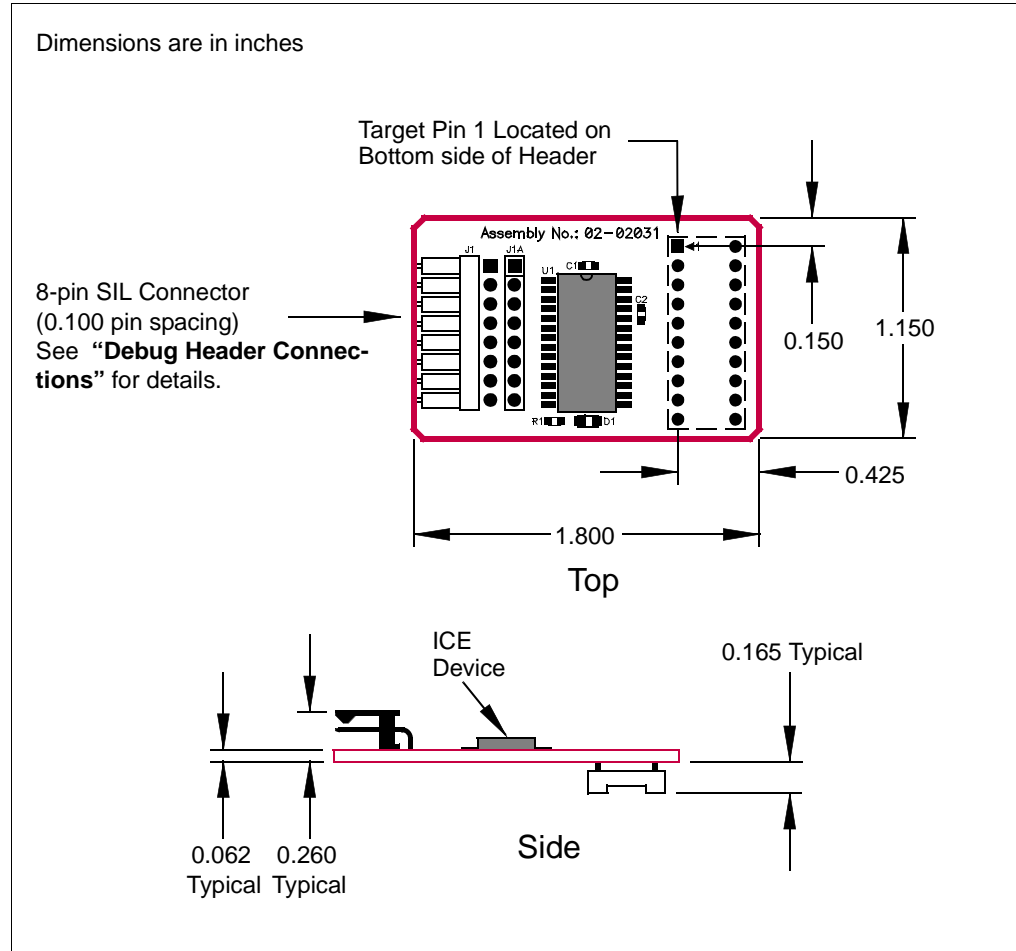

# Processor Extension Pak and Header Specification

---

NOTES:

## Debug Header Target Footprints

### INTRODUCTION

To connect a debug header directly to a target board (without the use of a transition socket) the following information will be helpful.

- DIP Device Footprints
- TQFP/PLCC Device Footprints

### DIP DEVICE FOOTPRINTS

DIP device adapter footprints shown will accept adapter plugs like Samtec series APA plugs. These plugs can be soldered in place during development/emulation and eliminate the need for any other sockets.

**FIGURE 1: DIP FOOTPRINT**

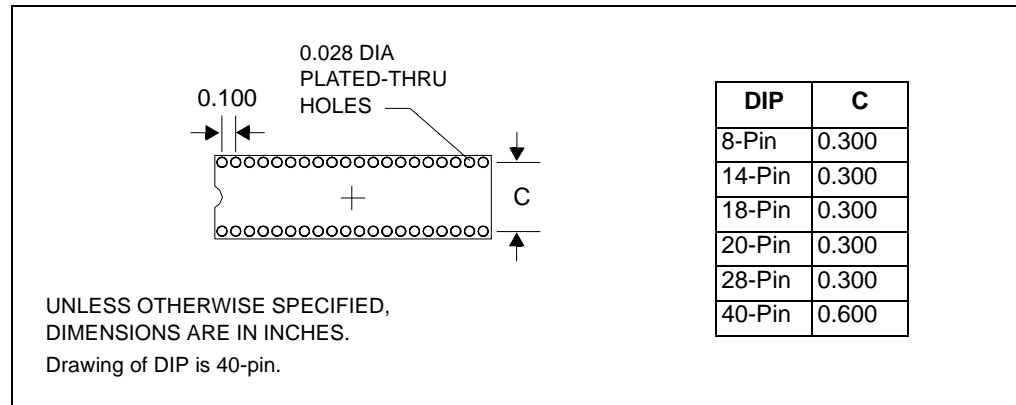

### TQFP/PLCC DEVICE FOOTPRINTS

TQFP/PLCC device adapter footprints shown will accept board stackers like Samtec series DWM 0.050 Pitch Stackers. These stackers can be soldered in place during development/emulation and eliminate the need for any other sockets.

**FIGURE 2: SINGLE-ROW TQFP/PLCC FOOTPRINT**

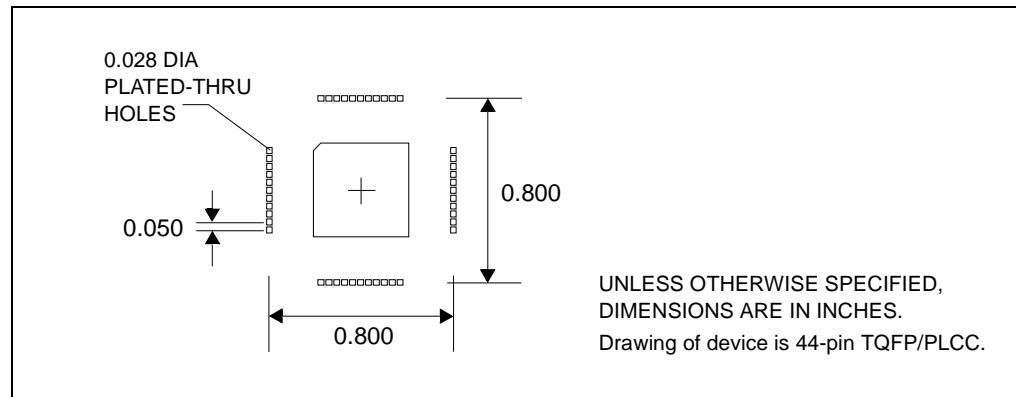

# Processor Extension Pak and Header Specification

**FIGURE 3: DOUBLE AND TRIPLE-ROW TQFP/PLCC FOOTPRINT**

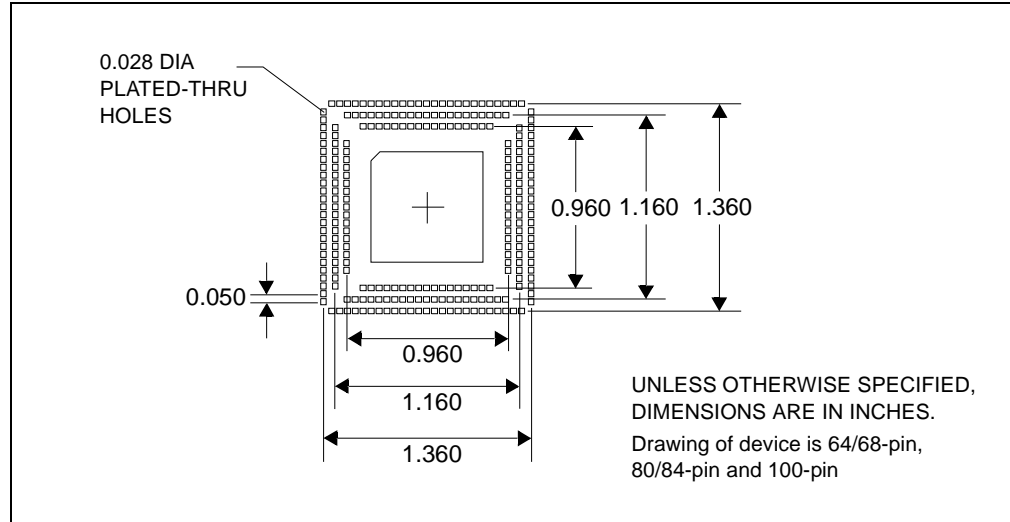

Header pin-out matches the PLCC package. PLCC will map to TQFP as follows:

- Header to 44-pin TQFP – one-to-one mapping.
- Header to 64-pin TQFP – see Figure 4 for mapping.
- Header to 80-pin TQFP – see Figure 5 for mapping.
- Header to 100-pin TQFP – one-to-one mapping.

**FIGURE 4: HEADER TO 64-PIN TQFP**

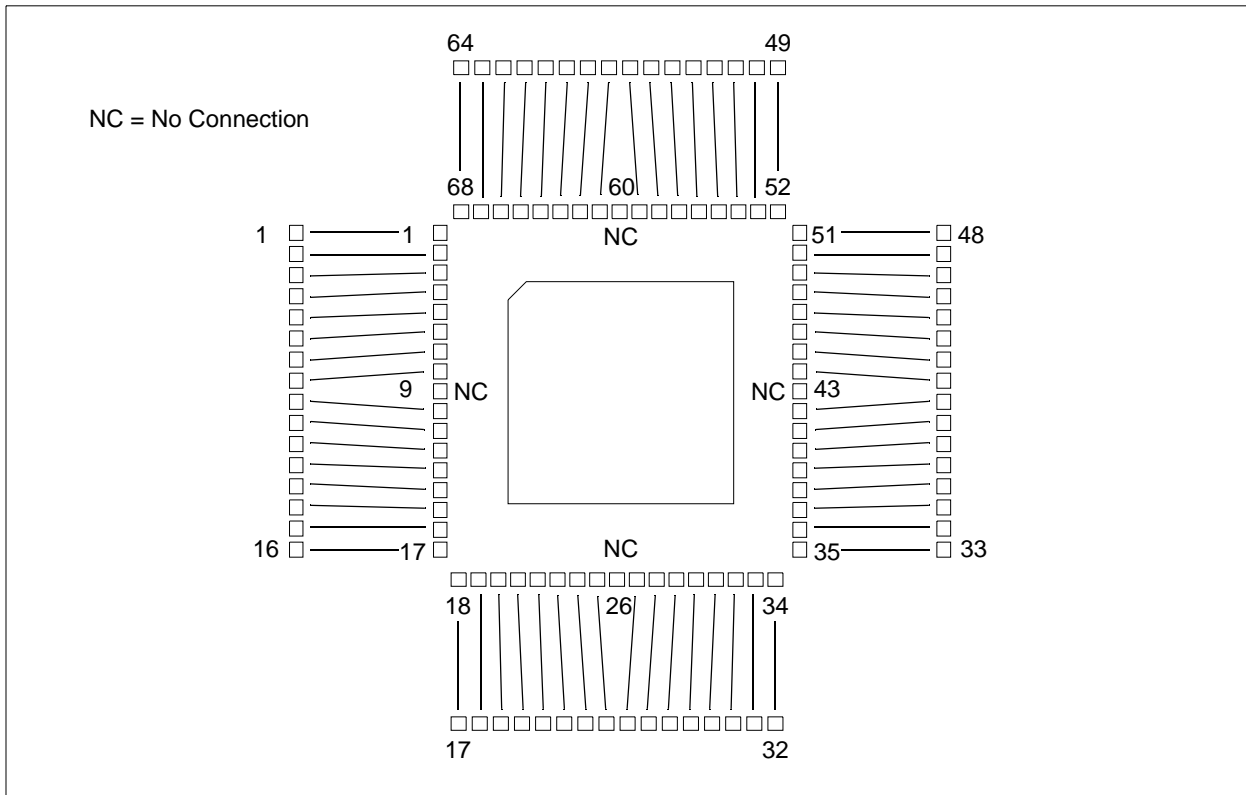





# Processor Extension Pak and Header Specification

---

NOTES:

---

---

## Debug Header Connections

---

---

### INTRODUCTION

The different types of debug header connectors are shown here, as well as information on connecting development tools to the header.

- 6-Pin Modular Connector
- 8-Pin SIL Connector
- 6-Pin SIL Connector
- SIL Optional Connection
- Modular-to-SIL Adapter
- Ordering Information

### 6-PIN MODULAR CONNECTOR

Debug headers with 6-pin modular (RJ-11/ICSP) connectors can connect directly with the following tools:

- MPLAB REAL ICE In-Circuit Emulator (Standard Driver Board)
- MPLAB ICD 2 or 3

**FIGURE 1: MODULAR CONNECTION**

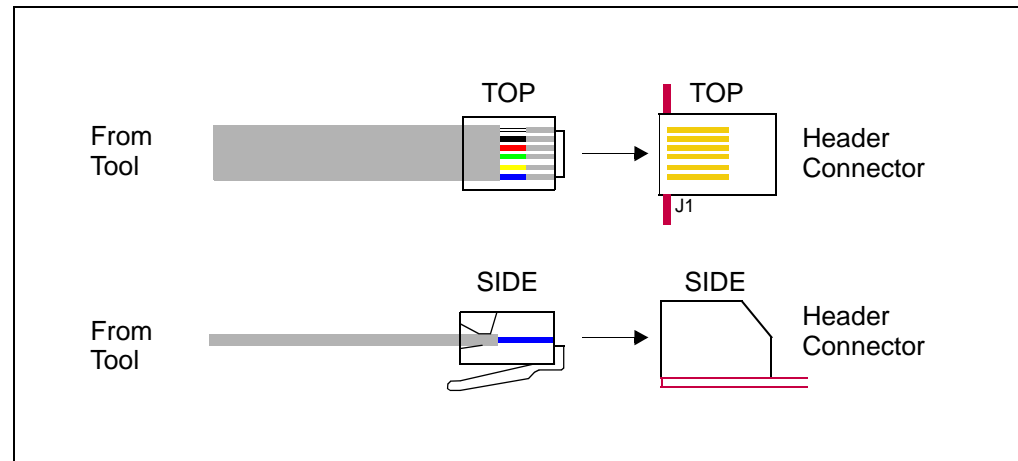

# Processor Extension Pak and Header Specification

## 8-PIN SIL CONNECTOR

Debug headers with 8-pin SIL (Single In-Line) connectors are compatible with the tools listed below.

### PICkit 2 or 3 Programmer/Debug Express

The 6-pin socket of the PICkit 2 or PICkit 3 may be connected to the 8 header pins by removing the two DAT and CLK pins. However, this may compromise future use of these pins/functions with other tools.

**FIGURE 2: 8-PIN SIL CONNECTION TO A PICKIT**

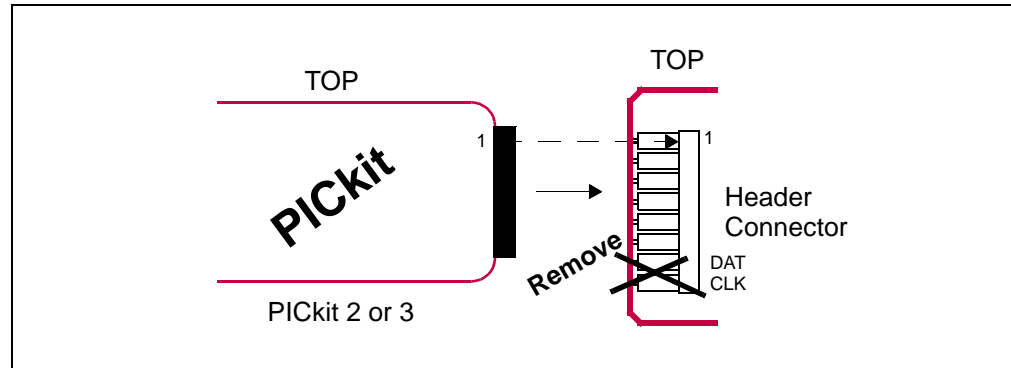

### MPLAB ICD 2 or 3 In-Circuit Debugger

The 6-pin modular cable attached to the MPLAB ICD 2 or MPLAB ICD 3 may be connected to the 8 header pins through the Modular-to-SIL Adapter.

### MPLAB REAL ICE In-Circuit Emulator

The 6-pin modular cable attached to the Standard Driver Board may be connected to the 8 header pins through the Modular-to-SIL Adapter. No SPI trace is available with this connection because of the loss of the DAT and CLK pins.

The 8-pin socket of the High Speed Driver Board or optional Isolation Unit may be directly connected to the 8 header pins. Be sure to line up pin 1 on the board with pin 1 on the header.

**FIGURE 3: 8-PIN SIL CONNECTION TO AN EMULATOR**

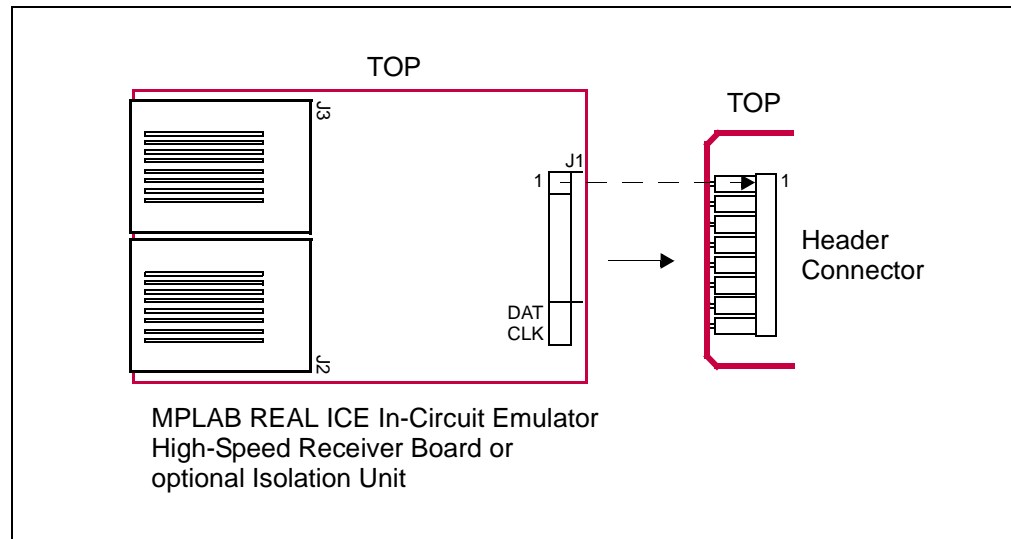

## 6-PIN SIL CONNECTOR

Debug headers with 6-pin SIL (Single In-Line) connectors are compatible with the tools listed below.

### PICkit 2 or 3 Programmer/Debug Express

The 6-pin socket of the PICkit 2 or PICkit 3 may be directly connected to the 6 header pins. Be sure to line up pin 1 on PICkit with pin 1 on header.

**FIGURE 4: 6-PIN SIL CONNECTION TO A PICKIT**

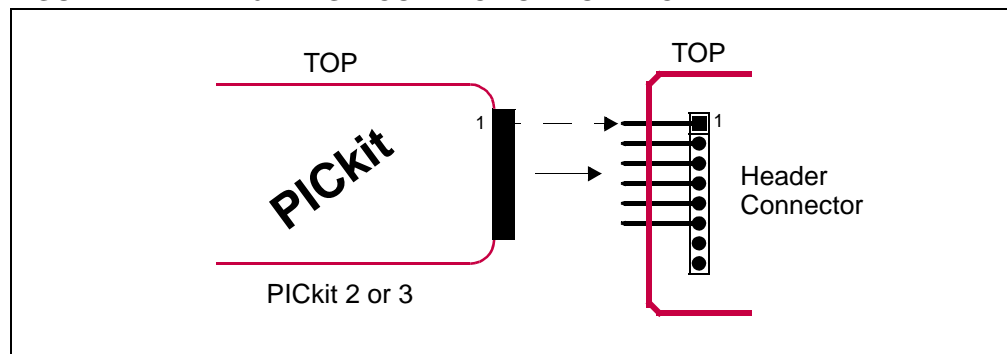

### MPLAB ICD 2 or 3 In-Circuit Debugger

The 6-pin modular cable attached to the MPLAB ICD 2 or MPLAB ICD 3 may be connected to the 6 header pins through the Modular-to-SIL Adapter.

### MPLAB REAL ICE In-Circuit Emulator

The 6-pin modular cable attached to the Standard Driver Board may be connected to the 6 header pins through the Modular-to-SIL Adapter. No SPI trace is available with this connection because of the loss of the DAT and CLK pins.

The 8-pin socket of the High Speed Driver Board or optional Isolation Unit may be directly connected to the 6 header pins. Be sure to line up pin 1 on the board with pin 1 on the header.

**Note:** No SPI trace is possible in this case because of the loss of DAT and CLK pins. However, if the device supports SPI, two additional header pins can be attached to add this functionality.

**FIGURE 5: 6-PIN SIL CONNECTION TO AN EMULATOR**

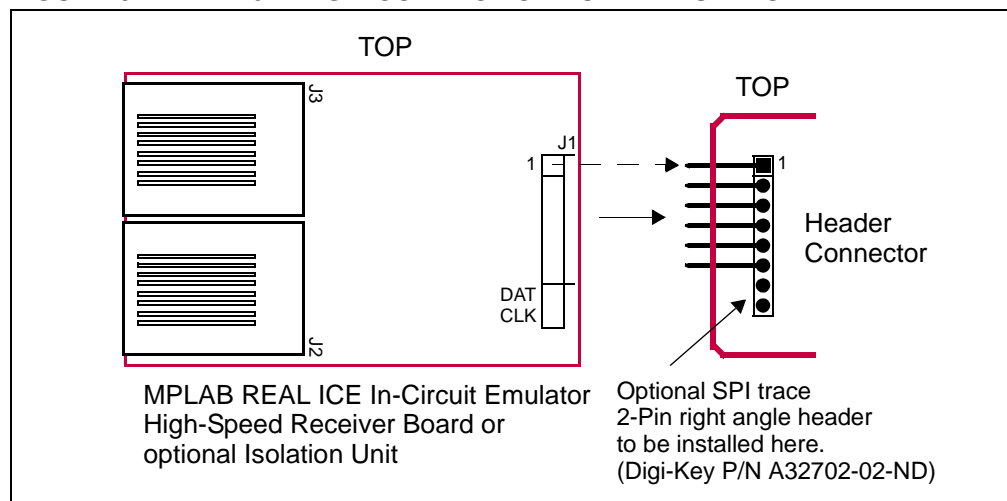

# Processor Extension Pak and Header Specification

## SIL OPTIONAL CONNECTION

Debug headers with 6- and 8-pin SIL connectors have an additional unpopulated connector available for customer use. This connector has the same pinout as the SIL connector. Solder wires to access individual pins or attach an entire vertical connector.

**FIGURE 6: SIL OPTIONAL CONNECTION**

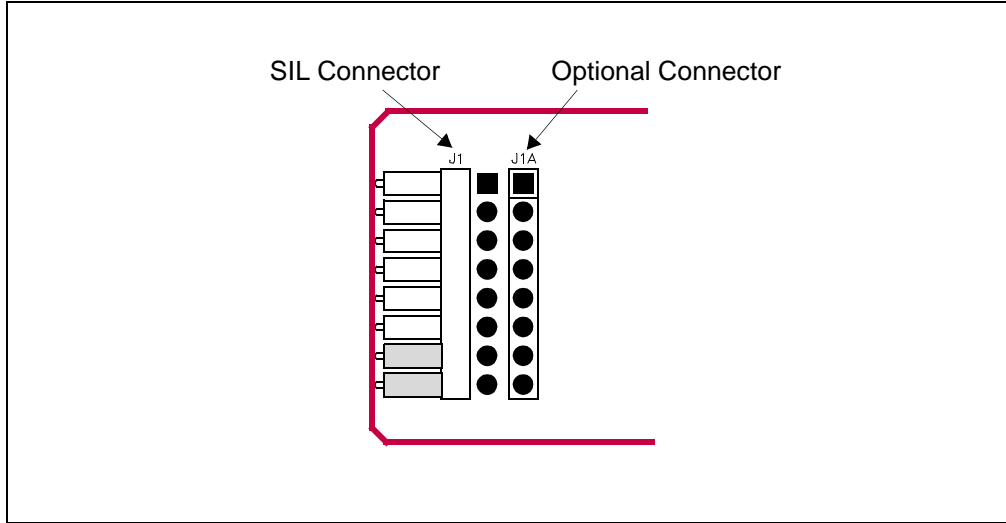

## MODULAR-TO-SIL ADAPTER

To adapt a 6-pin modular connector to an 8-pin SIL (Single In-Line) connector, you can use this adapter. You can also use this adapter for a 6-pin modular connector to an 6-pin SIL connector. In either case, **line up pin 1 of J1 with pin 1** of the 6- or 8-pin header connector.

**FIGURE 7: MODULAR-TO-SIL ADAPTER CONNECTION**

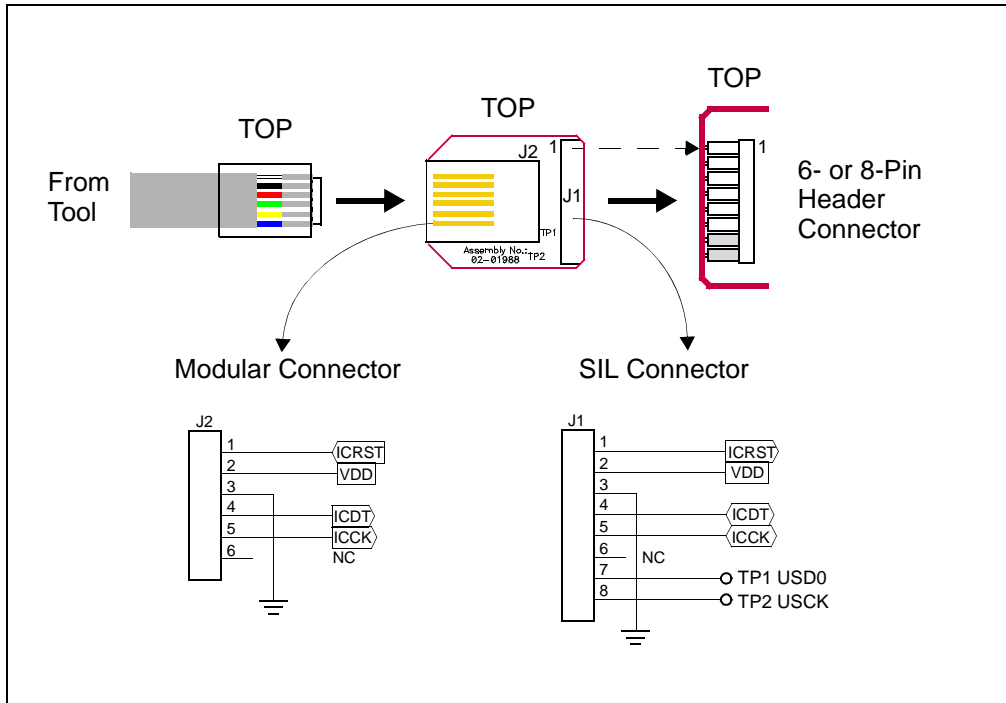

## ORDERING INFORMATION

To order the development tools and other hardware shown here, please refer to the table below.

**TABLE 5-1: MICROCHIP HARDWARE ORDERING NUMBERS**

Hardware	Order #
MPLAB REAL ICE in-circuit emulator (Standard Communication)	DV244005
MPLAB REAL ICE in-circuit emulator (High-Speed Communication) - Performance Pak	AC244002
MPLAB REAL ICE Isolation Unit (works with High-Speed Communication)	AC244005
MPLAB ICD 2	DV164005
MPLAB ICD 3	DV164035
PICkit 2 Debug Express	DV164121
PICkit 3 Debug Express	DV164131
Modular-to-SIL Adapter	AC164110

# Processor Extension Pak and Header Specification

---

NOTES:



## APPENDIX C: REVISION HISTORY

### C.1 Revision N (February 2006)

- Added Appendix A: Revision History
- Updated document to reflect support of additional tools
- Additional minor corrections throughout document text

### C.2 Revision P (September 2007)

- Updated document to reflect support of additional tools
- Additional minor corrections throughout document text

### C.3 Revision Q (December 2008)

- Added limitations to header setup sections as needed.
- Changed “ICD Headers” and “ICE Headers” to “Required Headers” and “Optional Headers” and move sections as necessary.
- Rearranged sections to organize by header (AC) number.

### C.4 Revision R (April 2009)

- Added board dimensions
- Removed header pinouts
- Added board identification info
- Added “why use a header” section
- Added footprint appendix
- Changed MPLAB ICD 2 and MPLAB ICD 3 references to generic debug tool
- Added MPLAB REAL ICE in-circuit emulator and MPLAB ICD 3 as programmers

### C.5 Revision S (July 2010)

- Added AC244028
- Added Header Connections chapter
- Added AC244033, AC244034
- Moved limitations to common Limitations file and added small section referencing Help files
- Added PIC12F617 to AC162083

### C.6 Revision T (February 2012)

- Added AC244043 and AC244044 and associated devices
- Removed Header Setup and Operation for AC244045

### C.7 Revision U (June 2012)

- Name changed from “Debug Header Specification” to “Processor Extension Pak & Header Specification”.
- “Processor Extension Pak and Header Defined” section added.
- “MPLAB IDE and MPLAB X IDE Use with Headers” section added.

# Processor Extension Pak and Header Specification

---

---

NOTES:

## Index

### Numerics

6-Pin Modular Connector .....	75
6-Pin SIL Connector .....	77
8-Pin SIL Connector .....	76

### A

AC162050 .....	11
AC162052 .....	13
AC162053 .....	15
AC162054 .....	15
AC162055 .....	13
AC162056 .....	13
AC162057 .....	13
AC162058 .....	11
AC162059 .....	17
AC162060 .....	19
AC162061 .....	21
AC162062 .....	41
AC162064 .....	43
AC162065 .....	45
AC162066 .....	23
AC162067 .....	48
AC162070 .....	17
AC162074 .....	48
AC162078 .....	51
AC162079 .....	41
AC162083 .....	25
AC162087 .....	41
AC162088 .....	54
AC162091 .....	41
AC162094 .....	54
AC162096 .....	17
AC244022 .....	45
AC244023 .....	28
AC244024 .....	28
AC244026 .....	57
AC244027 .....	57
AC244028 .....	30
AC244033 .....	60
AC244034 .....	60
AC244035 .....	62
AC244036 .....	62
AC244043 .....	64
AC244044 .....	64
AC244045 .....	32
AC244046 .....	66
AC244047 .....	66
AC244051 .....	34
AC244052 .....	34
AC244053 .....	68
AC244054 .....	68

Additional Information .....	7
------------------------------	---

### C

Calibration Bits .....	7
------------------------	---

### I

ICE vs. ICD .....	3
-------------------	---

### J

Jumper Settings 11, 13, 19, 23, 30, 41, 48, 51, 54, 57, 58, .....	62
--	----

### M

Modular Connector .....	75
Modular-to-SIL Adapter .....	78
MPLAB ICE 2000 .....	23

### O

Ordering Hardware .....	79
-------------------------	----

### P

PCM16YM0 .....	23
Performance .....	7
PIC10F200 .....	9
PIC10F202 .....	9
PIC10F204 .....	9
PIC10F206 .....	9
PIC10F220 .....	9
PIC10F222 .....	9
PIC10F320 .....	9
PIC10F322 .....	9
PIC10LF320 .....	9
PIC10LF322 .....	9
PIC12F1501 .....	9
PIC12F1822 .....	37, 38
PIC12F1840 .....	37, 38
PIC12F508 .....	9
PIC12F509 .....	9
PIC12F510 .....	9
PIC12F519 .....	9
PIC12F609 .....	9, 25
PIC12F615 .....	9, 25
PIC12F617 .....	9, 25
PIC12F629 .....	9, 11
PIC12F635 .....	9, 13
PIC12F675 .....	9, 11
PIC12F683 .....	9, 11
PIC12HV609 .....	9, 25
PIC12HV615 .....	9, 25
PIC12LF1501 .....	9
PIC16F1454 .....	37
PIC16F1455 .....	37
PIC16F1458 .....	37

# Processor Extension Pak and Header Specification

---

PIC16F1459 .....	37	PIC16LF1934 .....	38
PIC16F1503 .....	10	PIC16LF1936 .....	38
PIC16F1507 .....	10	PIC16LF1937 .....	38
PIC16F1508 .....	37	PIC16LF1938 .....	38
PIC16F1509 .....	37	PIC16LF1939 .....	38
PIC16F1823 .....	37, 38	PIC16LF722 .....	37
PIC16F1824 .....	37, 38	PIC16LF723 .....	37
PIC16F1825 .....	37, 38	PIC16LF724 .....	37
PIC16F1826 .....	37	PIC16LF726 .....	37
PIC16F1827 .....	37	PIC16LF727 .....	37
PIC16F1829 .....	37, 38	PIC18F1230 .....	38, 51
PIC16F1847 .....	37	PIC18F1330 .....	38, 51
PIC16F1933 .....	38	PIC18F13K22 .....	38
PIC16F1934 .....	38	PIC18F13K50 .....	10
PIC16F1936 .....	38	PIC18F14K22 .....	38
PIC16F1937 .....	38	PIC18F14K50 .....	10
PIC16F1938 .....	38	PIC18F24J10 .....	38
PIC16F1939 .....	38	PIC18F25J10 .....	38, 48
PIC16F505 .....	9	PIC18F44J10 .....	38
PIC16F506 .....	9	PIC18F45J10 .....	38, 48
PIC16F526 .....	9	PIC18F63J11 .....	39
PIC16F610 .....	9, 25	PIC18F63J90 .....	39
PIC16F616 .....	9, 25	PIC18F64J11 .....	39
PIC16F627A .....	9, 15	PIC18F64J16 .....	39
PIC16F628A .....	9, 15	PIC18F64J90 .....	39
PIC16F630 .....	9, 13	PIC18F64J95 .....	39
PIC16F631 .....	10, 21	PIC18F65J10 .....	39
PIC16F636 .....	10, 13	PIC18F65J11 .....	39
PIC16F639 .....	10, 23	PIC18F65J15 .....	39
PIC16F648A .....	10, 15	PIC18F65J16 .....	39
PIC16F676 .....	10, 13	PIC18F65J50 .....	39
PIC16F677 .....	10, 21	PIC18F65J55 .....	39
PIC16F684 .....	10, 13	PIC18F65J90 .....	39
PIC16F685 .....	10, 21	PIC18F66J10 .....	39
PIC16F687 .....	10, 21	PIC18F66J11 .....	39
PIC16F688 .....	10, 13	PIC18F66J15 .....	39
PIC16F689 .....	10, 21	PIC18F66J16 .....	39
PIC16F690 .....	10, 21	PIC18F66J50 .....	39
PIC16F716 .....	10, 15	PIC18F66J55 .....	39
PIC16F722 .....	37	PIC18F66J60 .....	40
PIC16F723 .....	37	PIC18F66J65 .....	40
PIC16F724 .....	37	PIC18F67J10 .....	39
PIC16F726 .....	37	PIC18F67J11 .....	39
PIC16F727 .....	37	PIC18F67J50 .....	39
PIC16F785 .....	10, 19	PIC18F67J60 .....	40
PIC16HV610 .....	9, 25	PIC18F83J11 .....	39
PIC16HV616 .....	9, 25	PIC18F83J90 .....	39
PIC16HV785 .....	10, 19	PIC18F84J11 .....	39
PIC16LF1454 .....	37	PIC18F84J16 .....	39
PIC16LF1455 .....	37	PIC18F84J90 .....	39
PIC16LF1458 .....	37	PIC18F84J95 .....	39
PIC16LF1459 .....	37	PIC18F85J10 .....	39
PIC16LF1503 .....	10	PIC18F85J11 .....	39
PIC16LF1507 .....	10	PIC18F85J15 .....	39
PIC16LF1508 .....	37	PIC18F85J16 .....	39
PIC16LF1509 .....	37	PIC18F85J50 .....	39
PIC16LF1826 .....	38	PIC18F85J55 .....	39
PIC16LF1827 .....	38	PIC18F85J90 .....	39
PIC16LF1847 .....	38	PIC18F86J10 .....	39
PIC16LF1933 .....	38	PIC18F86J11 .....	39

PIC18F86J15 .....	39
PIC18F86J16 .....	39
PIC18F86J50 .....	39
PIC18F86J55 .....	39
PIC18F86J60 .....	40
PIC18F86J65 .....	40
PIC18F87J10 .....	39
PIC18F87J11 .....	39
PIC18F87J50 .....	39
PIC18F87J60 .....	40
PIC18F96J60 .....	40
PIC18F96J65 .....	40
PIC18F97J60 .....	40
PIC18LF13K22 .....	38
PIC18LF13K50 .....	10
PIC18LF14K22 .....	38
PIC18LF14K50 .....	10
PIC18LF24J10 .....	38
PIC18LF25J10 .....	38, 48
PIC18LF44J10 .....	38
PIC18LF45J10 .....	38, 48
PIC24F04KA200 .....	10
PIC24F04KA201 .....	10
PIC24F08KA101 .....	40
PIC24F08KA102 .....	40
PIC24F16KA101 .....	40
PIC24F16KA102 .....	40
PIC24FJ128GA006 .....	40
PIC24FJ128GA008 .....	40
PIC24FJ128GA010 .....	40
PIC24FJ16GA002 .....	40
PIC24FJ16GA004 .....	40
PIC24FJ32GA002 .....	40
PIC24FJ32GA004 .....	40
PIC24FJ48GA002 .....	40
PIC24FJ48GA004 .....	40
PIC24FJ64GA002 .....	40
PIC24FJ64GA004 .....	40
PIC24FJ64GA006 .....	40
PIC24FJ64GA008 .....	40
PIC24FJ64GA010 .....	40
PIC24FJ96GA006 .....	40
PIC24FJ96GA008 .....	40
PIC24FJ96GA010 .....	40
PICDEM HPC Explorer Board .....	41
Pin Count .....	9, 37
Programming Non-ICD Devices .....	4
<b>S</b>	
SIL Connector, 6 Pin .....	77
SIL Connector, 8 Pin .....	76
Switch Settings .....	21
Switch Settings, Rotary .....	25
<b>T</b>	
Transition Socket .....	5
<b>V</b>	
Vdd Max .....	9, 37
Vddcore Max .....	9, 37

# Processor Extension Pak and Header Specification

---

NOTES:

---

**Note the following details of the code protection feature on Microchip devices:**

- Microchip products meet the specification contained in their particular Microchip Data Sheet.
- Microchip believes that its family of products is one of the most secure families of its kind on the market today, when used in the intended manner and under normal conditions.
- There are dishonest and possibly illegal methods used to breach the code protection feature. All of these methods, to our knowledge, require using the Microchip products in a manner outside the operating specifications contained in Microchip's Data Sheets. Most likely, the person doing so is engaged in theft of intellectual property.
- Microchip is willing to work with the customer who is concerned about the integrity of their code.
- Neither Microchip nor any other semiconductor manufacturer can guarantee the security of their code. Code protection does not mean that we are guaranteeing the product as “unbreakable.”

Code protection is constantly evolving. We at Microchip are committed to continuously improving the code protection features of our products. Attempts to break Microchip's code protection feature may be a violation of the Digital Millennium Copyright Act. If such acts allow unauthorized access to your software or other copyrighted work, you may have a right to sue for relief under that Act.

---

Information contained in this publication regarding device applications and the like is provided only for your convenience and may be superseded by updates. It is your responsibility to ensure that your application meets with your specifications. MICROCHIP MAKES NO REPRESENTATIONS OR WARRANTIES OF ANY KIND WHETHER EXPRESS OR IMPLIED, WRITTEN OR ORAL, STATUTORY OR OTHERWISE, RELATED TO THE INFORMATION, INCLUDING BUT NOT LIMITED TO ITS CONDITION, QUALITY, PERFORMANCE, MERCHANTABILITY OR FITNESS FOR PURPOSE. Microchip disclaims all liability arising from this information and its use. Use of Microchip devices in life support and/or safety applications is entirely at the buyer's risk, and the buyer agrees to defend, indemnify and hold harmless Microchip from any and all damages, claims, suits, or expenses resulting from such use. No licenses are conveyed, implicitly or otherwise, under any Microchip intellectual property rights.

**Trademarks**

The Microchip name and logo, the Microchip logo, dsPIC, KEELOQ, KEELOQ logo, MPLAB, PIC, PICmicro, PICSTART, PIC<sup>32</sup> logo, rfPIC and UNI/O are registered trademarks of Microchip Technology Incorporated in the U.S.A. and other countries.

FilterLab, Hampshire, HI-TECH C, Linear Active Thermistor, MXDEV, MXLAB, SEEVAL and The Embedded Control Solutions Company are registered trademarks of Microchip Technology Incorporated in the U.S.A.

Analog-for-the-Digital Age, Application Maestro, chipKIT, chipKIT logo, CodeGuard, dsPICDEM, dsPICDEM.net, dsPICworks, dsSPEAK, ECAN, ECONOMONITOR, FanSense, HI-TIDE, In-Circuit Serial Programming, ICSP, Mindi, MiWi, MPASM, MPLAB Certified logo, MPLIB, MPLINK, mTouch, Omniscient Code Generation, PICC, PICC-18, PICDEM, PICDEM.net, PICKit, PICtail, REAL ICE, rfLAB, Select Mode, Total Endurance, TSHARC, UniWinDriver, WiperLock and ZENA are trademarks of Microchip Technology Incorporated in the U.S.A. and other countries.

SQTP is a service mark of Microchip Technology Incorporated in the U.S.A.

All other trademarks mentioned herein are property of their respective companies.

© 2006-2012, Microchip Technology Incorporated, Printed in the U.S.A., All Rights Reserved.

 Printed on recycled paper.

ISBN: 978-1-62076-317-9

*Microchip received ISO/TS-16949:2009 certification for its worldwide headquarters, design and wafer fabrication facilities in Chandler and Tempe, Arizona; Gresham, Oregon and design centers in California and India. The Company's quality system processes and procedures are for its PIC<sup>®</sup> MCUs and dsPIC<sup>®</sup> DSCs, KEELOQ<sup>®</sup> code hopping devices, Serial EEPROMs, microperipherals, nonvolatile memory and analog products. In addition, Microchip's quality system for the design and manufacture of development systems is ISO 9001:2000 certified.*

---

**QUALITY MANAGEMENT SYSTEM  
CERTIFIED BY DNV  
= ISO/TS 16949 =**



---

---

## Worldwide Sales and Service

---

---

### AMERICAS

**Corporate Office**  
2355 West Chandler Blvd.  
Chandler, AZ 85224-6199  
Tel: 480-792-7200  
Fax: 480-792-7277  
Technical Support:  
[http://www.microchip.com/  
support](http://www.microchip.com/support)  
Web Address:  
[www.microchip.com](http://www.microchip.com)

**Atlanta**  
Duluth, GA  
Tel: 678-957-9614  
Fax: 678-957-1455

**Boston**  
Westborough, MA  
Tel: 774-760-0087  
Fax: 774-760-0088

**Chicago**  
Itasca, IL  
Tel: 630-285-0071  
Fax: 630-285-0075

**Cleveland**  
Independence, OH  
Tel: 216-447-0464  
Fax: 216-447-0643

**Dallas**  
Addison, TX  
Tel: 972-818-7423  
Fax: 972-818-2924

**Detroit**  
Farmington Hills, MI  
Tel: 248-538-2250  
Fax: 248-538-2260

**Indianapolis**  
Noblesville, IN  
Tel: 317-773-8323  
Fax: 317-773-5453

**Los Angeles**  
Mission Viejo, CA  
Tel: 949-462-9523  
Fax: 949-462-9608

**Santa Clara**  
Santa Clara, CA  
Tel: 408-961-6444  
Fax: 408-961-6445

**Toronto**  
Mississauga, Ontario,  
Canada  
Tel: 905-673-0699  
Fax: 905-673-6509

### ASIA/PACIFIC

**Asia Pacific Office**  
Suites 3707-14, 37th Floor  
Tower 6, The Gateway  
Harbour City, Kowloon  
Hong Kong  
Tel: 852-2401-1200  
Fax: 852-2401-3431

**Australia - Sydney**  
Tel: 61-2-9868-6733  
Fax: 61-2-9868-6755

**China - Beijing**  
Tel: 86-10-8569-7000  
Fax: 86-10-8528-2104

**China - Chengdu**  
Tel: 86-28-8665-5511  
Fax: 86-28-8665-7889

**China - Chongqing**  
Tel: 86-23-8980-9588  
Fax: 86-23-8980-9500

**China - Hangzhou**  
Tel: 86-571-2819-3187  
Fax: 86-571-2819-3189

**China - Hong Kong SAR**  
Tel: 852-2401-1200  
Fax: 852-2401-3431

**China - Nanjing**  
Tel: 86-25-8473-2460  
Fax: 86-25-8473-2470

**China - Qingdao**  
Tel: 86-532-8502-7355  
Fax: 86-532-8502-7205

**China - Shanghai**  
Tel: 86-21-5407-5533  
Fax: 86-21-5407-5066

**China - Shenyang**  
Tel: 86-24-2334-2829  
Fax: 86-24-2334-2393

**China - Shenzhen**  
Tel: 86-755-8203-2660  
Fax: 86-755-8203-1760

**China - Wuhan**  
Tel: 86-27-5980-5300  
Fax: 86-27-5980-5118

**China - Xian**  
Tel: 86-29-8833-7252  
Fax: 86-29-8833-7256

**China - Xiamen**  
Tel: 86-592-2388138  
Fax: 86-592-2388130

**China - Zhuhai**  
Tel: 86-756-3210040  
Fax: 86-756-3210049

### ASIA/PACIFIC

**India - Bangalore**  
Tel: 91-80-3090-4444  
Fax: 91-80-3090-4123

**India - New Delhi**  
Tel: 91-11-4160-8631  
Fax: 91-11-4160-8632

**India - Pune**  
Tel: 91-20-2566-1512  
Fax: 91-20-2566-1513

**Japan - Osaka**  
Tel: 81-66-152-7160  
Fax: 81-66-152-9310

**Japan - Yokohama**  
Tel: 81-45-471-6166  
Fax: 81-45-471-6122

**Korea - Daegu**  
Tel: 82-53-744-4301  
Fax: 82-53-744-4302

**Korea - Seoul**  
Tel: 82-2-554-7200  
Fax: 82-2-558-5932 or  
82-2-558-5934

**Malaysia - Kuala Lumpur**  
Tel: 60-3-6201-9857  
Fax: 60-3-6201-9859

**Malaysia - Penang**  
Tel: 60-4-227-8870  
Fax: 60-4-227-4068

**Philippines - Manila**  
Tel: 63-2-634-9065  
Fax: 63-2-634-9069

**Singapore**  
Tel: 65-6334-8870  
Fax: 65-6334-8850

**Taiwan - Hsin Chu**  
Tel: 886-3-5778-366  
Fax: 886-3-5770-955

**Taiwan - Kaohsiung**  
Tel: 886-7-536-4818  
Fax: 886-7-330-9305

**Taiwan - Taipei**  
Tel: 886-2-2500-6610  
Fax: 886-2-2508-0102

**Thailand - Bangkok**  
Tel: 66-2-694-1351  
Fax: 66-2-694-1350

### EUROPE

**Austria - Wels**  
Tel: 43-7242-2244-39  
Fax: 43-7242-2244-393

**Denmark - Copenhagen**  
Tel: 45-4450-2828  
Fax: 45-4485-2829

**France - Paris**  
Tel: 33-1-69-53-63-20  
Fax: 33-1-69-30-90-79

**Germany - Munich**  
Tel: 49-89-627-144-0  
Fax: 49-89-627-144-44

**Italy - Milan**  
Tel: 39-0331-742611  
Fax: 39-0331-466781

**Netherlands - Drunen**  
Tel: 31-416-690399  
Fax: 31-416-690340

**Spain - Madrid**  
Tel: 34-91-708-08-90  
Fax: 34-91-708-08-91

**UK - Wokingham**  
Tel: 44-118-921-5869  
Fax: 44-118-921-5820

11/29/11





## Стандарт Электрон Связь

Мы молодая и активно развивающаяся компания в области поставок электронных компонентов. Мы поставляем электронные компоненты отечественного и импортного производства напрямую от производителей и с крупнейших складов мира.

Благодаря сотрудничеству с мировыми поставщиками мы осуществляем комплексные и плановые поставки широчайшего спектра электронных компонентов.

Собственная эффективная логистика и склад в обеспечивает надежную поставку продукции в точно указанные сроки по всей России.

Мы осуществляем техническую поддержку нашим клиентам и предпродажную проверку качества продукции. На все поставляемые продукты мы предоставляем гарантию .

Осуществляем поставки продукции под контролем ВП МО РФ на предприятия военно-промышленного комплекса России , а также работаем в рамках 275 ФЗ с открытием отдельных счетов в уполномоченном банке. Система менеджмента качества компании соответствует требованиям ГОСТ ISO 9001.

Минимальные сроки поставки, гибкие цены, неограниченный ассортимент и индивидуальный подход к клиентам являются основой для выстраивания долгосрочного и эффективного сотрудничества с предприятиями радиоэлектронной промышленности, предприятиями ВПК и научно-исследовательскими институтами России.

С нами вы становитесь еще успешнее!

### Наши контакты:

**Телефон:** +7 812 627 14 35

**Электронная почта:** [sales@st-electron.ru](mailto:sales@st-electron.ru)

**Адрес:** 198099, Санкт-Петербург,  
Промышленная ул, дом № 19, литера Н,  
помещение 100-Н Офис 331