

MAX14851 Evaluation Kit

Evaluates: MAX14851

General Description

The MAX14851 evaluation kit (EV kit) is a fully assembled and tested circuit board that demonstrates the functionality of the MAX14851 6-channel digital isolator in a 16-pin QSOP package. The EV kit features an on-board isolated power supply and is powered from a single supply.

Features

- Operates from a Single Supply
- 600V_{RMS} Isolation for 60s
- Proven PCB Layout
- Fully Assembled and Tested

Ordering Information appears at end of data sheet.

Quick Start

Required Equipment

- MAX14851 EV kit
- 5V DC power supply
- Signal/function generator
- Oscilloscope

Startup Procedure

The EV kit is fully assembled and tested. Follow the steps below to verify board operation:

- 1) Set the power supply to 5V and connect it to the EV kit board between the 5V and GNDA test points (TP1 and TP2, respectively).
- 2) Turn on the power supply.
- 3) Connect a function/signal generator to the INA1 test point (TP3) and set the output to a 1MHz 0 to 5V square wave. Verify that the signal on OUTB1 (TP4) switches as the input signal toggles.

Detailed Description of Hardware

The MAX14851 EV kit is a fully assembled and tested circuit board for evaluating the MAX14851 6-channel digital isolator (U1) in a 16-pin QSOP package.

Powering the MAX13851 EV Kit

The MAX14851 EV kit includes an on-board MAX258 isolated power supply circuit to transfer power from the A-side of the board to the B-side. Connect an external supply to the 5V (TP1) and GNDA (TP2) test points. An on-board MAX258 H-bridge driver circuit (U3) and a MAX8881 LDO (U2) generate an isolated 3.3V supply to power the secondary (B) side of the board.

To bypass the MAX258 circuit and power the board with external supplies, remove the shunts on the J1 and J2 jumpers. Connect a supply between 3V and 5.5V to the 5V test point (TP1), this powers the A-side of the board (VCCA). Connect a supply between 3V and 5.5V to the 3.3V test point (TP24) to power the B-side of the board (VCCB).

Evaluating the MAX14851

The EV kit is powered from a single 5V and is designed to be evaluated alone or dropped into an existing circuit for easy in-system analysis.

All inputs (INA_, INB_) and I/O pins (I/OA_, I/OB_) have an associated test point. Connect a signal generator to the test point for the desired input and monitor the signal on the output of that channel.

Evaluating the MAX14851 in an Isolated RS-485 Configuration

Figure 1 shows a simplified connection diagram for evaluating the MAX14851 in an isolated RS-485 circuit. The high-speed unidirectional channels are used for data channels DI and RO. Bidirectional channels can be used for the enable lines (DE and RE), where lower speed is acceptable.

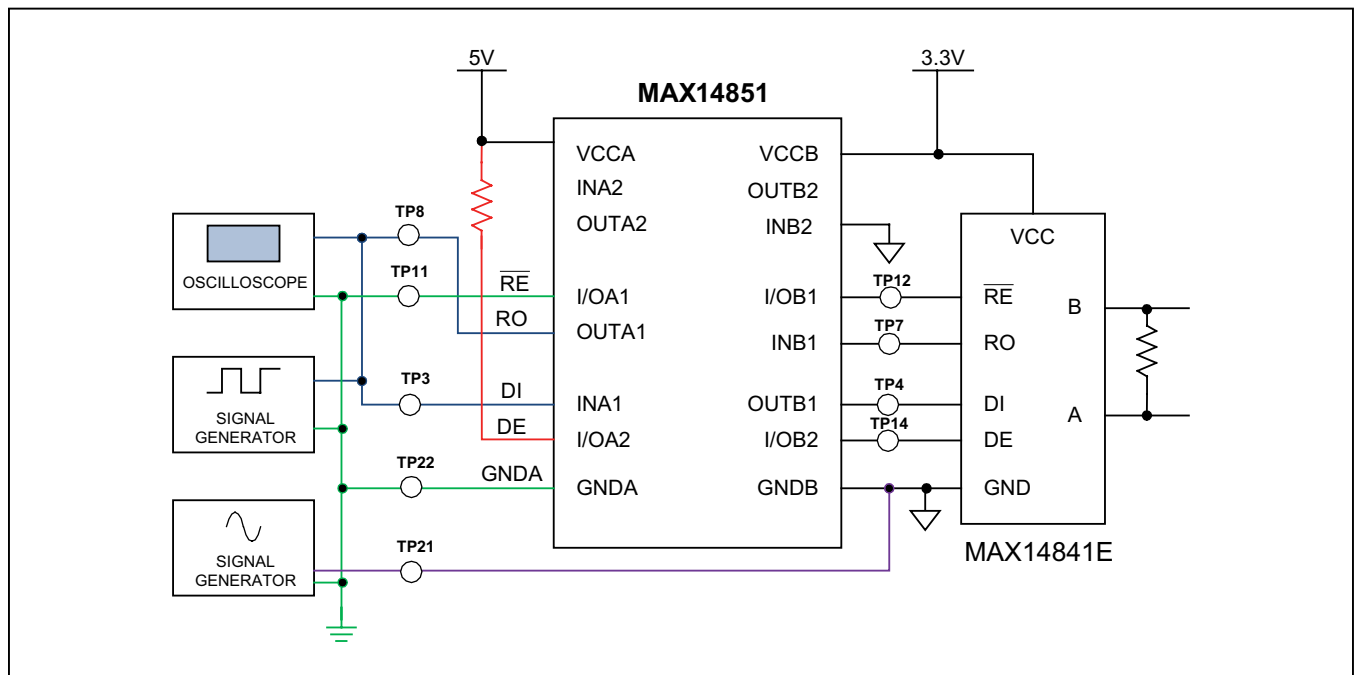

Figure 1. Simplified Connection Diagram for Evaluating the MAX14851 in an Isolated RS-485 Configuration

Evaluating the MAX14851 in an Isolated RS-232 Configuration

Figure 2 is a simplified connection diagram for evaluating the MAX14851 in an isolated RS-232 configuration.

Evaluating the MAX14851 in an Isolated I²C Configuration

Figure 3 is a simplified connection diagram for evaluating the MAX14851 in an isolated I²C interface. The bidirectional channels with pullups are used to level shift the data and clock signals and transmits them across the isolation barrier.

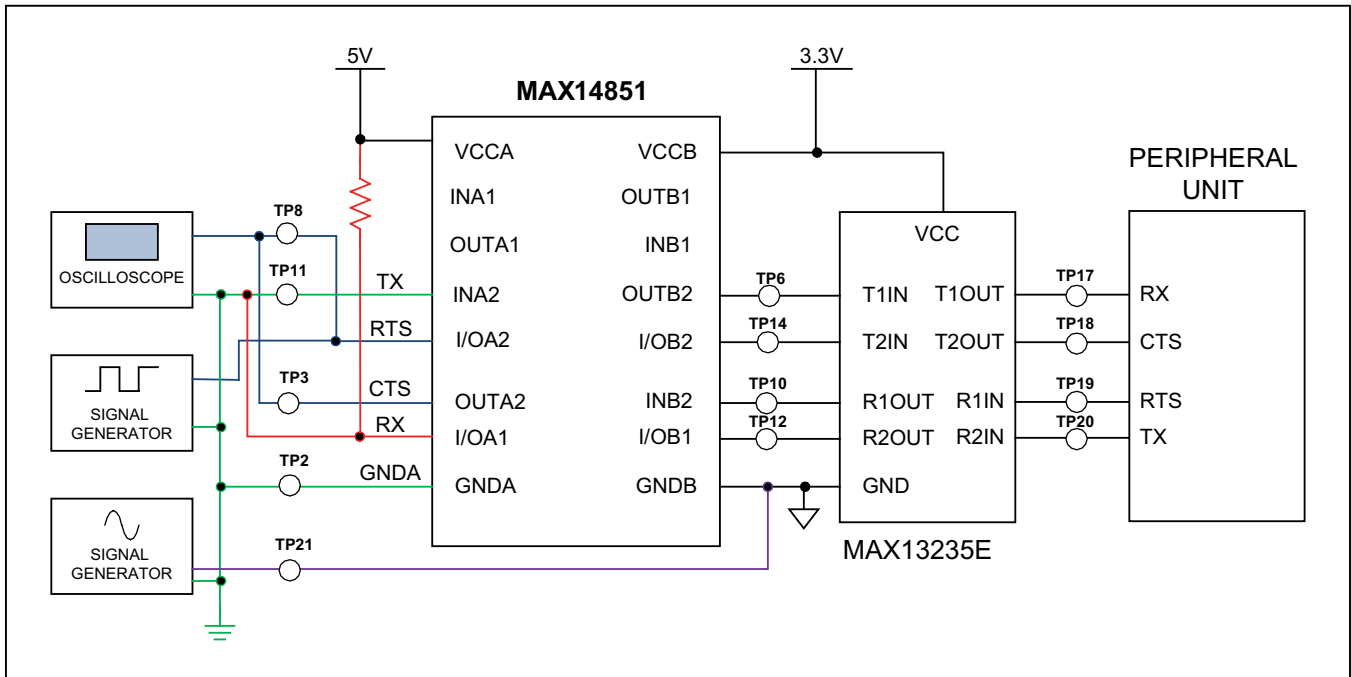

Figure 2. Simplified Connection Diagram for Evaluating the MAX14851 in an Isolated RS-232 Configuration

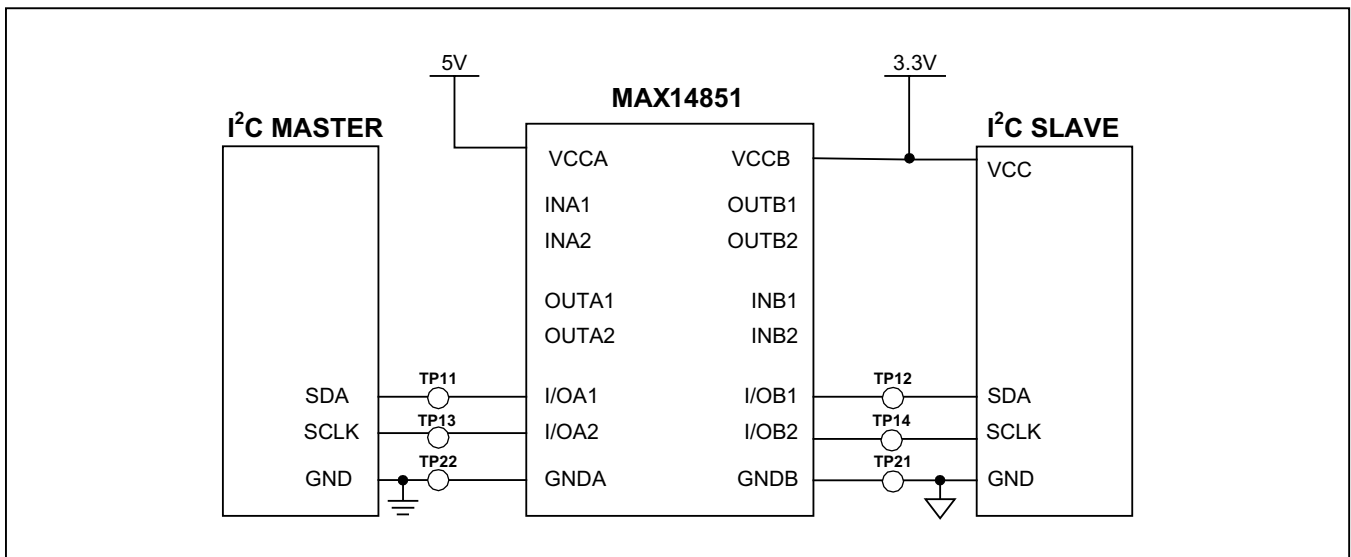

Figure 3. Simplified Connection Diagram for Evaluating the MAX14851 in an Isolated I²C Configuration

Evaluating the MAX14851 in an Isolated SPI/MICROWIRE® Configuration

Figure 4 is a simplified connection diagram for evaluating the MAX14851 in an isolated SPI/MICROWIRE interface. High speed and bidirectional channels are used to level shift the data and clock signals and transmits them across the isolation barrier.

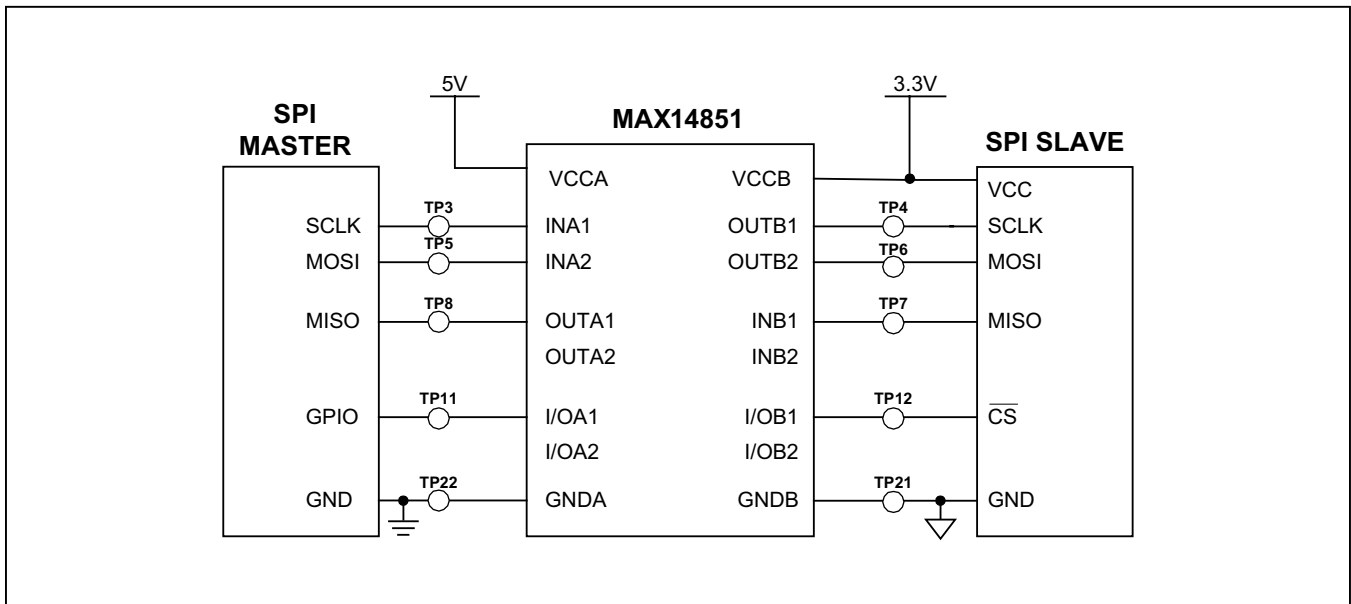

Figure 4. Simplified Connection Diagram for Evaluating the MAX14851 in an Isolated SPI Configuration

Ordering Information

PART	TYPE
MAX14851EVKIT#	EV Kit

#Denotes RoHS compliant.

MAX14851 EV Kit Bill of Materials

ITEM	REF_DES	DNI/DNP	QTY	MFG PART #	MANUFACTURER	VALUE	DESCRIPTION
1	C1	—	1	TMK212BBJ106KG-T; CL21A106KAFN3N	TAIYO YUDEN	10µF	CAPACITOR; SMT (0805); CERAMIC CHIP; 10µF; 25V; TOL = 10%; MODEL = ; TG = -55°C TO +85°C; TC = X5R
2	C2	—	1	C0603C105K4RAC; GRM188R71C105KA12; C1608X7R1C105K; EMK107B7105KA	KEMET/MURATA/ TDK/TAIYO YUDEN	1µF	CAPACITOR; SMT (0603); CERAMIC CHIP; 1µF; 16V; TOL = 10%; MODEL = ; TG = -55°C TO +125°C; TC = X7R
3	C3	—	1	GRM219R71E105K	MURATA	1µF	CAPACITOR; SMT (0805); CERAMIC CHIP; 1µF; 25V; TOL = 10%; TG = -55°C TO +125°C; TC = X7R
4	C4	—	1	GRM21BR71A475KA73; LMK212B7475KG-T; C2012X7R1A475K125AC	MURATA; TAIYO YUDEN; TDK	4.7µF	CAPACITOR; SMT (0805); CERAMIC CHIP; 4.7µF; 10V; TOL = 10%; TG = -55°C TO +125°C; TC = X7R
5	C5, C6	—	2	GCJ188R71H104KA12; GCM188R71H104K; CGA3E2X7R1H104K080AA	MURATA; TDK	0.1µF	CAPACITOR; SMT (0603); CERAMIC CHIP; 0.1µF; 50V; TOL = 10%; TG = -55°C TO +125°C; TC = X7R; AUTO
6	C7	—	1	GRM188R60J105KA01	MURATA	1µF	CAPACITOR; SMT (0603); CERAMIC CHIP; 1µF; 6.3V; TOL = 10%; MODEL = GRM SERIES; TG = -55°C TO +85°C; TC = X5R;
7	D2, D3	—	2	MBR140SFT1G	ON SEMICONDUCTOR	MBR140SFT1G	DIODE; SCH; SMT (SOD-123FL); PIV = 40V; IF = 1A
8	J1, J2	—	2	TSW-102-23-G-S	SAMTEC	TSW-102-23-G-S	CONNECTOR; THROUGH HOLE; SINGLE ROW; STRAIGHT; 2PINS; -55°C TO +125°C
9	J3	—	1	TSW-103-23-G-S	SAMTEC	TSW-103-23-G-S	CONNECTOR; THROUGH HOLE; SINGLE ROW; STRAIGHT; 3PINS; -55°C TO +125°C
10	R5-R8	—	4	CRCW06032K00FK; ERJ-3EKF2001V	VISHAY DALE/PANASONIC	2K	RESISTOR, 0603, 2KΩ, 1%, 100PPM, 0.10W, THICK FILM
11	T1	—	1	750315090	WURTH ELECTRONICS INC	750315090	TRANSFORMER; SMT; 1:1; MID-PPMAX PUSH-PULL TRANSFORMER;
12	TP1, TP24	—	2	5010	KEYSTONE	N/A	TESTPOINT WITH 1.80MM HOLE DIA, RED, MULTIPURPOSE;
13	TP2, TP21-TP23	—	4	5011	KEYSTONE	N/A	TEST POINT; PIN DIA = 0.125IN; TOTAL LENGTH = 0.445IN; BOARD HOLE = 0.063IN; BLACK; PHOSPHOR BRONZE WIRE SILVER PLATE FINISH;
14	TP3-TP14	—	12	5012	KEYSTONE	N/A	TEST POINT; PIN DIA = 0.125IN; TOTAL LENGTH = 0.445IN; BOARD HOLE = 0.063IN; WHITE; PHOSPHOR BRONZE WIRE SILVER PLATE FINISH;
15	U1	—	1	MAX14851AEE+	MAXIM	MAX14851AEE+	EVKIT PART-IC; DISO; SIX-CHANNEL DIGITAL ISOLATOR, QSOP16
16	U2	—	1	MAX8881EUT33+	MAXIM	MAX8881EUT33	IC; VREG; ULTRA-LOW-IQ, LOW-DROPOUT LINEAR REGULATORS WITH POK, SOT23-6
17	U3	—	1	MAX258ATA+	MAXIM	MAX258ATA+	IC; DRV; 0.5A; PUSH-PULL TRANSFORMER DRIVER FOR ISOLATED POWER SUPPLY; TDFN8-EP 2X3
18	PCB	—	1	MAX14851	MAXIM	PCB	PCB:MAX14851
19	J4, J5	DNP	0	PBC08SAAN	SULLINS ELECTRONICS CORP.	PBC08SAAN	CONNECTOR; MALE; THROUGH HOLE; BREAKAWAY; STRAIGHT; 8PINS; -65°C TO +125°C
20	R1-R4	DNP	0	N/A	N/A	OPEN	RESISTOR, 0603; OPEN; FORMFACTOR

MAX14851 EV Kit Schematic

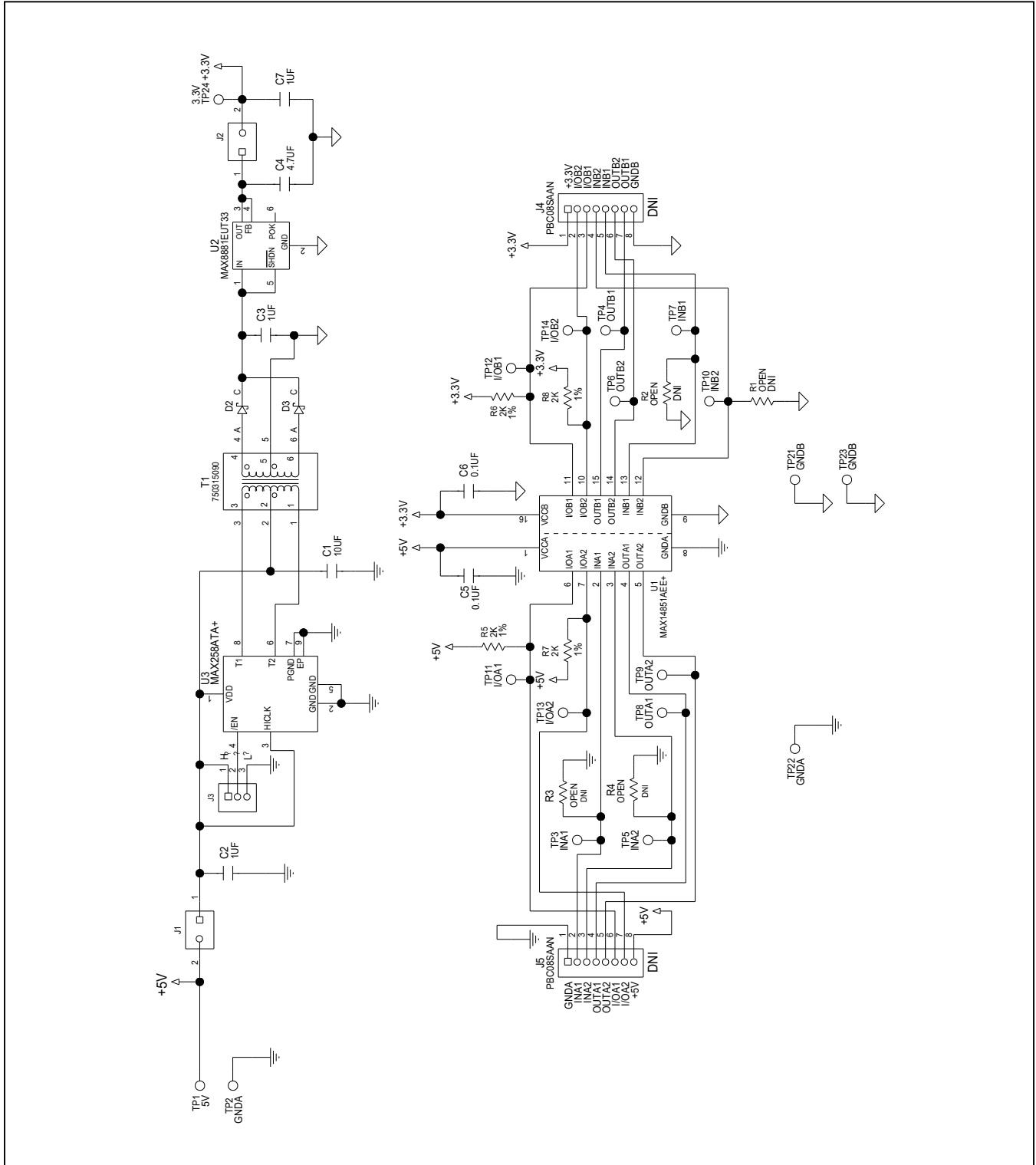

MAX14851 EV Kit PCB Layout Diagrams

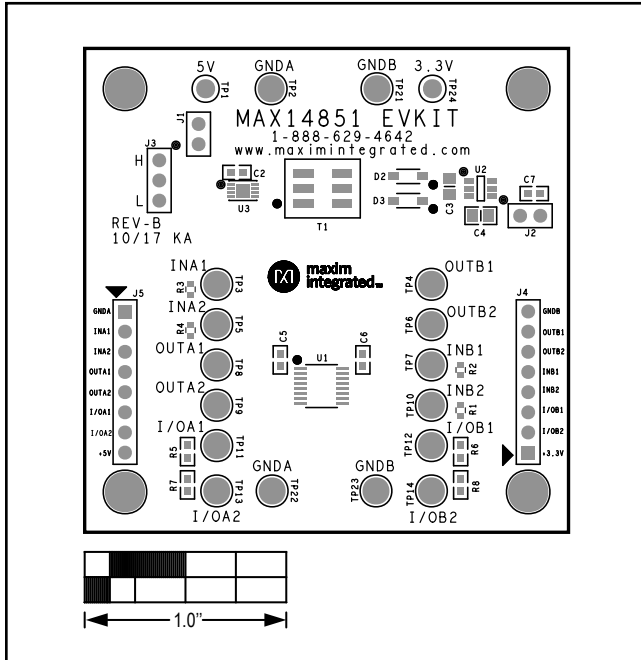

MAX14851 EV Kit—PCB Silkscreen Top Side

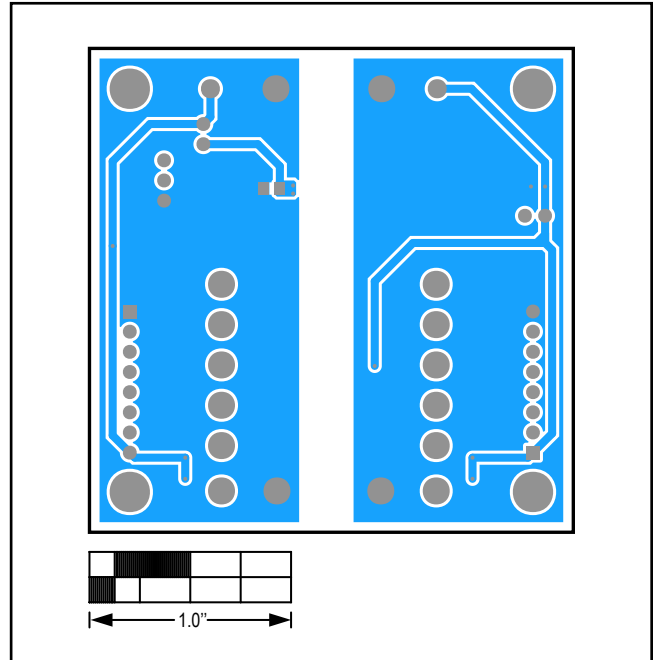

MAX14851 EV Kit—PCB Layout Bottom Side

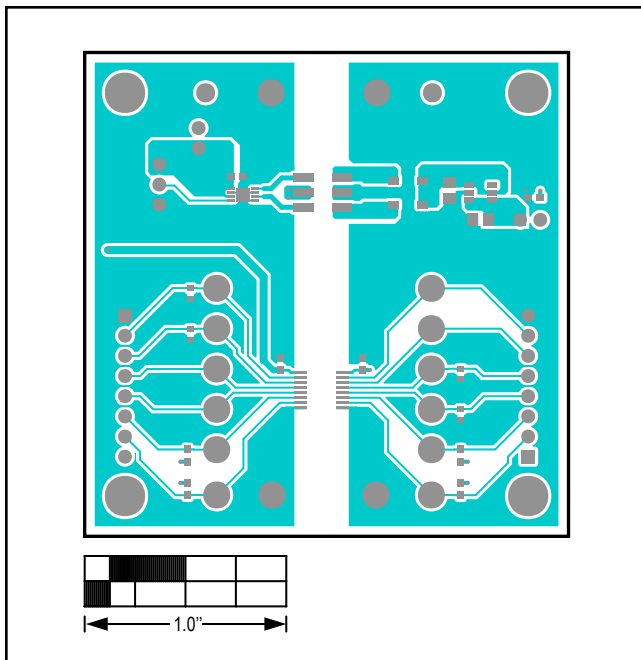

MAX14851 EV Kit—PCB Layout Top Side

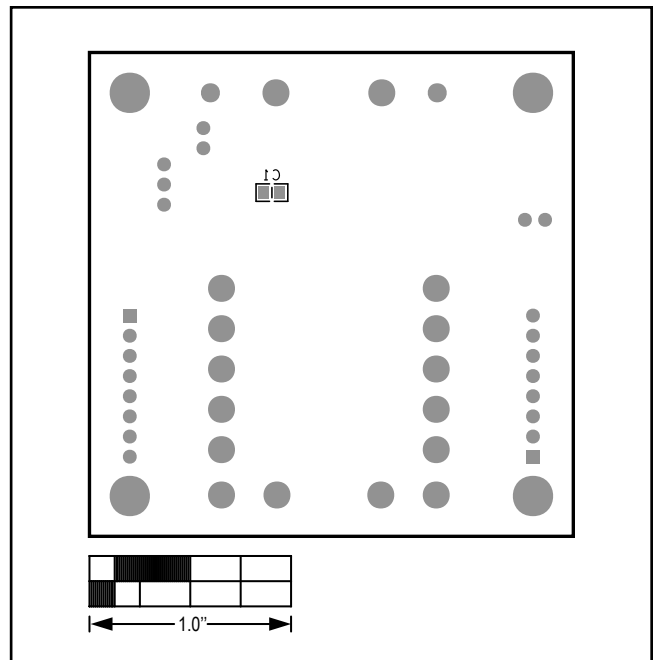

MAX14851 EV Kit—PCB Silkscreen Bottom Side

Revision History

REVISION NUMBER	REVISION DATE	DESCRIPTION	PAGES CHANGED
0	11/17	Initial release	—

For information on other Maxim Integrated products, visit Maxim Integrated's website at www.maximintegrated.com.

Maxim Integrated cannot assume responsibility for use of any circuitry other than circuitry entirely embodied in a Maxim Integrated product. No circuit patent licenses are implied. Maxim Integrated reserves the right to change the circuitry and specifications without notice at any time.



Стандарт Электрон Связь

Мы молодая и активно развивающаяся компания в области поставок электронных компонентов. Мы поставляем электронные компоненты отечественного и импортного производства напрямую от производителей и с крупнейших складов мира.

Благодаря сотрудничеству с мировыми поставщиками мы осуществляем комплексные и плановые поставки широчайшего спектра электронных компонентов.

Собственная эффективная логистика и склад в обеспечивает надежную поставку продукции в точно указанные сроки по всей России.

Мы осуществляем техническую поддержку нашим клиентам и предпродажную проверку качества продукции. На все поставляемые продукты мы предоставляем гарантию .

Осуществляем поставки продукции под контролем ВП МО РФ на предприятия военно-промышленного комплекса России , а также работаем в рамках 275 ФЗ с открытием отдельных счетов в уполномоченном банке. Система менеджмента качества компании соответствует требованиям ГОСТ ISO 9001.

Минимальные сроки поставки, гибкие цены, неограниченный ассортимент и индивидуальный подход к клиентам являются основой для выстраивания долгосрочного и эффективного сотрудничества с предприятиями радиоэлектронной промышленности, предприятиями ВПК и научно-исследовательскими институтами России.

С нами вы становитесь еще успешнее!

Наши контакты:

Телефон: +7 812 627 14 35

Электронная почта: sales@st-electron.ru

Адрес: 198099, Санкт-Петербург,
Промышленная ул, дом № 19, литера Н,
помещение 100-Н Офис 331