

PRODUCT NUMBER

SEE TABLE

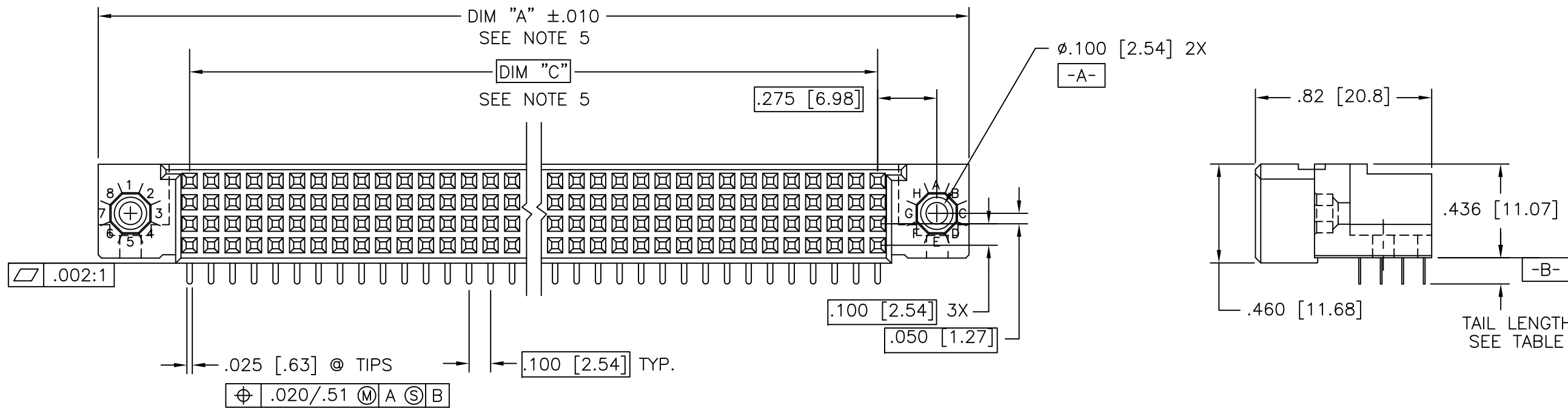
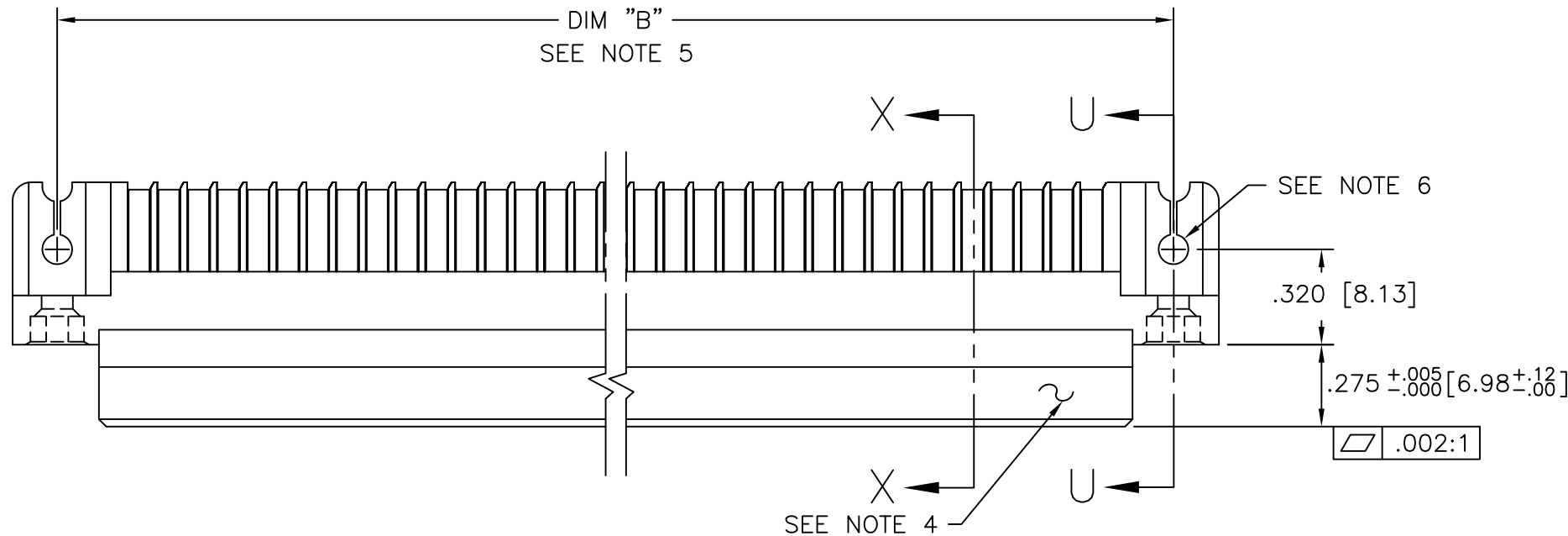

mat'l. code		surface		tolerance		projection		product family	
NOTE 3		ISO 1302 ✓		ISO 406 ISO 1101				HPC	
ltr	ecn no	dr	date	tolerances unless otherwise specified		INCH/MM		title	
T	ELX-I-26895	MJA	05/03/17	angles	linear			4 ROW R/A RECEPTACLE SOLDER TAIL, 0 GUIDE PIN	
-	-	-	-	0°±2'		scale 1:1			
M	V05-0207	VS	3/2/05						
N	V05-1052	HTB	12/7/05	dr	G.PETERS	6/4/96		dwg no	
P	M06-0283	MHT	7/27/06	enr	S.CLARK	6/3/96		sheet 1 of 5 size	
R	M07-0099	AGS	2/09/07	chr	M JACOB	05/03/17		50295 A3	
S	M08-0280	AGS	9/30/08	appd	BIJU K PAUL	05/03/17		type Product Customer Drawing	
sheet	revision	T	T	T	S	S			
index	sheet	1	2	3	4	5			

PRODUCT NUMBER
SEE TABLE

NOTES:

- ① PRODUCT NUMBERING CODE:
50295 - X YYY Z S LF
LEAD FREE (OPTIONAL)
SPECIAL FEATURES (NOTE 6)
TAIL LENGTH (SEE TABLE)
NO. OF POSITIONS (NOTE 2)
PLATING (SEE TABLE)
BASE NUMBER
- ② THIS PRODUCT IS CONFIGURED IN SIZES OF 6 thru 80 COLUMNS IN INCREMENTS OF ONE.
i.e.: 6,7,8,9.....79,80.
- ③ HOUSING MATERIAL: GLASS & MINERAL FILLED HIGH-TEMP THERMOPLASTIC, FLAME RETARDANT PER UL94 V-0.
CONTACT MATERIAL: BeCu
- ④ MANUFACTURE'S NAME, PART NUMBER AND LOT CODE TO APPEAR ON THIS SURFACE PER BUS-12-108.
- ⑤ LENGTH DIMENSION FORMULAS:
DIM "A" = $.100/2.54 \times \text{NO. OF COLUMNS} + .75/19.1$
DIM "B" = $.100/2.54 \times \text{NO. OF COLUMNS} + .450/11.43$
DIM "C" = $.100/2.54 \times \text{NO. OF COLUMNS} - .100/2.54$
- ⑥ SPECIAL FEATURES (SEE SHEET 3) AND TABLE.
- = IF CODE IS OMITTED FROM PRODUCT NUMBER: CONNECTOR IS PROVIDED AS SHOWN, NO SPECIAL FEATURES ARE SELECTED. FOR P.C.B. ATTACHEMENT IN A $\phi.120[3.05]$ MOUNTING HOLE.
"A" = IF SPECIFIED, PRE-INSTALLED CLAW FOR P.C.B. ATTACHEMENT IN A $\phi.100[2.54]$ MOUNTING HOLE. AVAILABLE IN 'E' TAIL LENGTH ONLY.
"B" = IF SPECIFIED, PRE-INSTALLED CLAW FOR P.C.B. ATTACHEMENT IN A $\phi.120[3.05]$ MOUNTING HOLE.
"C" = IF SPECIFIED, MOLDED GUIDE PINS WITH PRE-INSTALLED CLAW FOR P.C.B. ATTACHEMENT IN A $\phi.120[3.05]$ MOUNTING HOLE.
"D" = IF SPECIFIED, MOLDED GUIDE PINS WITH $\phi.100[2.54]$ MOUNTING HOLE (NO CLAW).
- ⑦ CLAW DIMENSION DETERMINED BY P.C.B. HOLE DIAMETER.
8. THIS PRODUCT (WITH "LF" SUFFIX) MEETS EUROPEAN UNION DIRECTIVES AND OTHER COUNTRY REGULATIONS AS DESCRIBED IN GS-22-008.
9. THIS HOUSING WILL WITHSTAND EXPOSURE TO 260 DEGREES C PEAK TEMPERATURE FOR 10-30 SECONDS IN A CONVECTION, INFRA-RED OR VAPOR PHASE REFLOW OVEN.
- ⑩ PLATING OPTION:
MAY BE EITHER GOLD OR GXT PLATED AT MANUFACTURER'S OPTION.

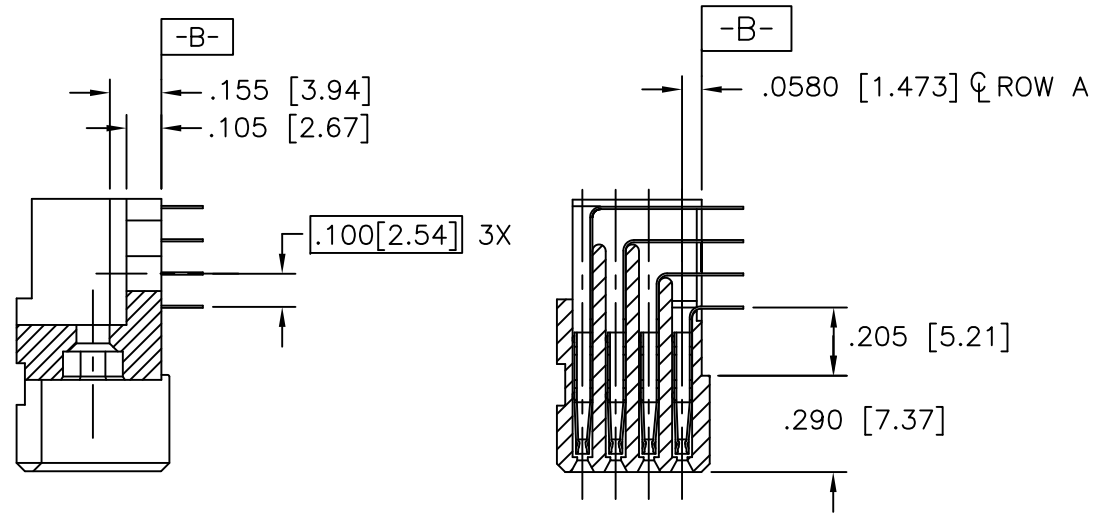

SECTION U-U NO SPECIAL FEATURE
SECTION X-X

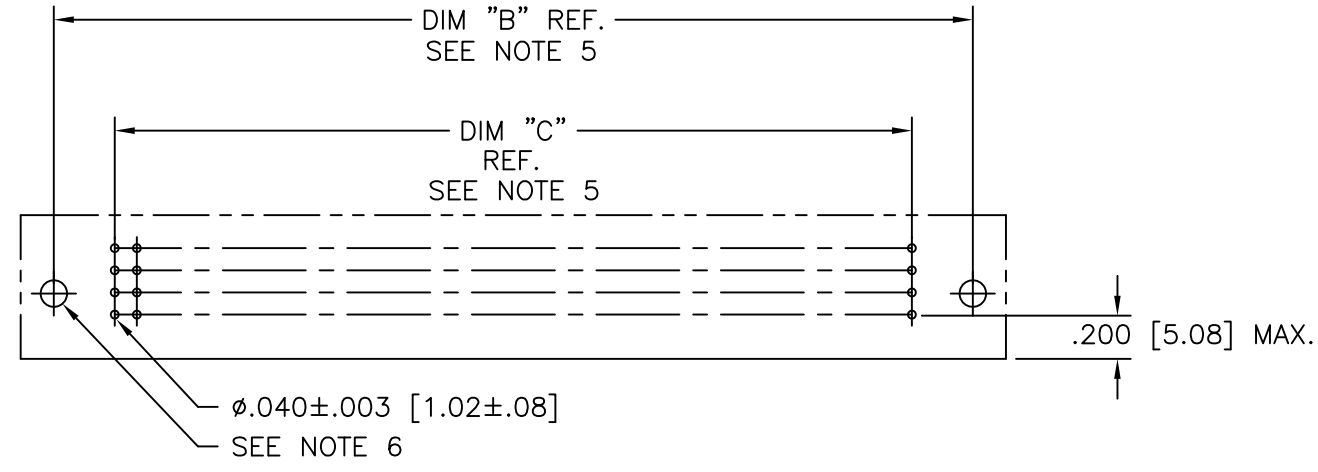

RECOMMENDED PCB LAYOUT
(ALL HOLES LOCATED ON .100 [2.54] GRID UNLESS OTHERWISE SPECIFIED)

mat'l. code NOTE 3		surface ISO 1302 ✓		tolerance ISO 406 ISO 1101		projection INCH/MM		product family HPC		
ltr	ecn no	dr	date	tolerances unless otherwise specified		INCH/MM		title 4 ROW R/A RECEPTACLE SOLDER TAIL, 0 GUIDE PIN		
T				angles	linear	scale 1:1		dwg no 50295		
				0°±2°				sheet 2 of 5 size A3		
				dr	G.PETERS	6/4/96	Amphenol FCi		type Product Customer Drawing	
				enr	S.CLARK	6/3/96				
				chr	M JACOB	05/03/17				
				appd	BIJU K PAUL	05/03/17				
sheet index	revision sheet									

PRODUCT NUMBER

SEE TABLE

SPECIAL FEATURE OPTION A

SPECIAL FEATURE OPTION B

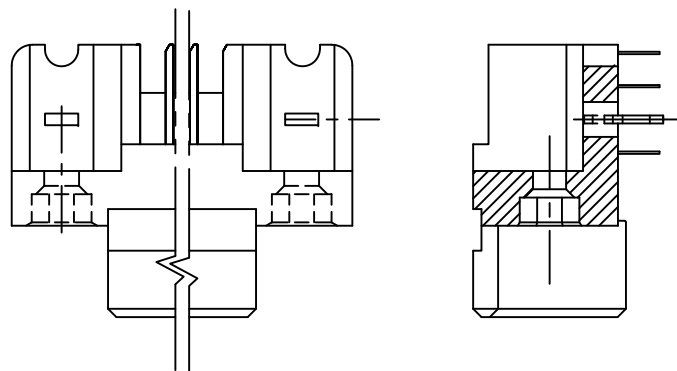

SECTION U-U

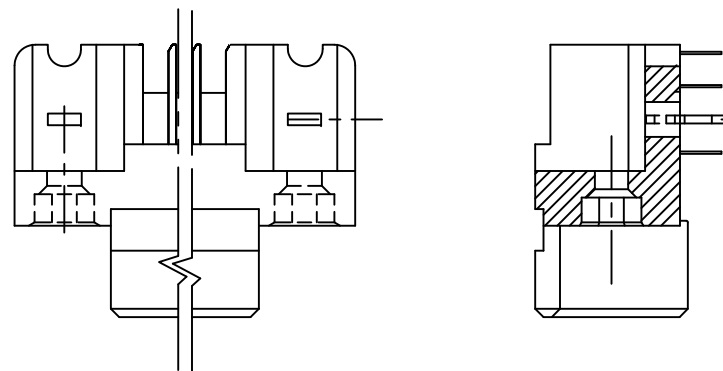

SECTION U-U

SPECIAL FEATURE OPTION C

SPECIAL FEATURE OPTION D

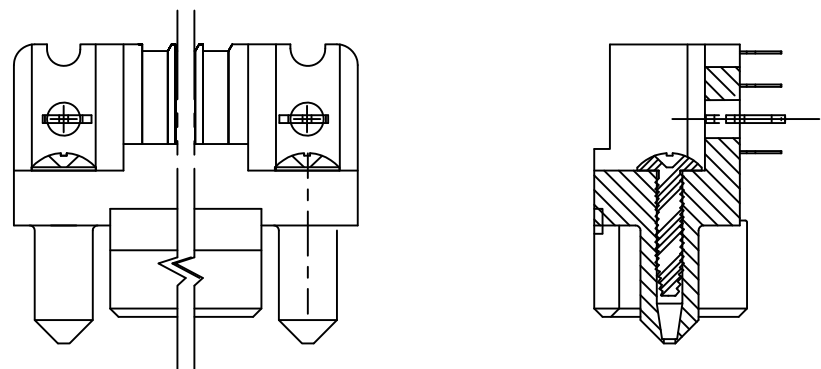

SECTION U-U

SELF TAPPING SCREW (2x)

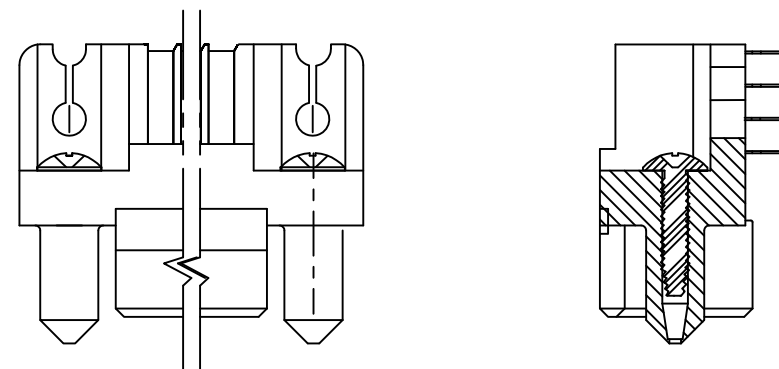

SECTION U-U

SELF TAPPING SCREW (2x)

NOTE 7

Amphenol FCI

Copyright AFCl

mat'l. code NOTE 3		surface ISO 1302 ✓	tolerance ISO 406 ISO 1101	projection 	product family HPC
ltr	ecn no	dr	date	tolerances unless otherwise specified	title 4 ROW R/A RECEPTACLE SOLDER TAIL, 0 GUIDE PIN
T				angles linear 0°±2°	
				linear .XX±.01/.X±0.3 .XXX±.005/.XX±0.13 .XXX±.0020/.XXX±0.051	
sheet index		revision sheet		dr G.PETERS 6/4/96	dwg no 50295
				enr S.CLARK 6/3/96	sheet 3 of 5 size A3
				chr M JACOB 05/03/17	type Product Customer Drawing
				appd BIJU K PAUL 05/03/17	

PRODUCT NUMBER NOTE 1 AND 2	NUMBER OF POSITIONS SEE NOTE 2	TAIL LENGTH ±.010/0.25	SPECIAL FEATURES SEE NOTE 6	TAIL PLATING	CONTACT PLATING SEE NOTE 10	PRODUCT NUMBER NOTE 1 AND 2	NUMBER OF POSITIONS SEE NOTE 2	TAIL LENGTH ±.010/0.25	SPECIAL FEATURES SEE NOTE 6	TAIL PLATING	CONTACT PLATING SEE NOTE 10
50295-1YYYE	YYY	.125/3.18	NONE	TIN-LEAD	30μ"/0.76μ Au	50295-1YYYELF	YYY	.125/3.18	NONE	TIN	30μ"/0.76μ Au
50295-1YYYEA	YYY	.125/3.18	"A"		30μ"/0.76μ Au	50295-1YYYEALF	YYY	.125/3.18	"A"		30μ"/0.76μ Au
50295-1YYYEB	YYY	.125/3.18	"B"		30μ"/0.76μ Au	50295-1YYYEBLF	YYY	.125/3.18	"B"		30μ"/0.76μ Au
50295-1YYYEC	YYY	.125/3.18	"C"		30μ"/0.76μ Au	50295-1YYYECLF	YYY	.125/3.18	"C"		30μ"/0.76μ Au
50295-1YYYED	YYY	.125/3.18	"D"		30μ"/0.76μ Au	50295-1YYYEDLF	YYY	.125/3.18	"D"		30μ"/0.76μ Au
50295-1YYYF	YYY	.145/3.68	NONE		30μ"/0.76μ Au	50295-1YYYFLF	YYY	.145/3.68	NONE		30μ"/0.76μ Au
50295-1YYYFB	YYY	.145/3.68	"B"		30μ"/0.76μ Au	50295-1YYYFBLF	YYY	.145/3.68	"B"		30μ"/0.76μ Au
50295-1YYYFC	YYY	.145/3.68	"C"		30μ"/0.76μ Au	50295-1YYYFCLF	YYY	.145/3.68	"C"		30μ"/0.76μ Au
50295-1YYYFD	YYY	.145/3.68	"D"		30μ"/0.76μ Au	50295-1YYYFDLF	YYY	.145/3.68	"D"		30μ"/0.76μ Au
50295-1YYYH	YYY	.180/4.57	NONE		30μ"/0.76μ Au	50295-1YYYHLF	YYY	.180/4.57	NONE		30μ"/0.76μ Au
50295-1YYYHB	YYY	.180/4.57	"B"		30μ"/0.76μ Au	50295-1YYYHBLF	YYY	.180/4.57	"B"		30μ"/0.76μ Au
50295-1YYYHC	YYY	.180/4.57	"C"		30μ"/0.76μ Au	50295-1YYYHCLF	YYY	.180/4.57	"C"		30μ"/0.76μ Au
50295-1YYYHD	YYY	.180/4.57	"D"		30μ"/0.76μ Au	50295-1YYYHDLF	YYY	.180/4.57	"D"		30μ"/0.76μ Au
50295-3YYYE	YYY	.125/3.18	NONE		50μ"/1.27μ Au	50295-3YYYELF	YYY	.125/3.18	NONE		50μ"/1.27μ Au
50295-3YYYEA	YYY	.125/3.18	"A"		50μ"/1.27μ Au	50295-3YYYEALF	YYY	.125/3.18	"A"		50μ"/1.27μ Au
50295-3YYYEB	YYY	.125/3.18	"B"		50μ"/1.27μ Au	50295-3YYYEBLF	YYY	.125/3.18	"B"		50μ"/1.27μ Au
50295-3YYYEC	YYY	.125/3.18	"C"		50μ"/1.27μ Au	50295-3YYYECLF	YYY	.125/3.18	"C"		50μ"/1.27μ Au
50295-3YYYED	YYY	.125/3.18	"D"		50μ"/1.27μ Au	50295-3YYYEDLF	YYY	.125/3.18	"D"		50μ"/1.27μ Au
50295-3YYYF	YYY	.145/3.68	NONE		50μ"/1.27μ Au	50295-3YYYFLF	YYY	.145/3.68	NONE		50μ"/1.27μ Au
50295-3YYYFB	YYY	.145/3.68	"B"		50μ"/1.27μ Au	50295-3YYYFBLF	YYY	.145/3.68	"B"		50μ"/1.27μ Au
50295-3YYYFC	YYY	.145/3.68	"C"		50μ"/1.27μ Au	50295-3YYYFCLF	YYY	.145/3.68	"C"		50μ"/1.27μ Au
50295-3YYYFD	YYY	.145/3.68	"D"		50μ"/1.27μ Au	50295-3YYYFDLF	YYY	.145/3.68	"D"		50μ"/1.27μ Au
50295-3YYYH	YYY	.180/4.57	NONE		50μ"/1.27μ Au	50295-3YYYHLF	YYY	.180/4.57	NONE		50μ"/1.27μ Au
50295-3YYYHB	YYY	.180/4.57	"B"		50μ"/1.27μ Au	50295-3YYYHBLF	YYY	.180/4.57	"B"		50μ"/1.27μ Au
50295-3YYYHC	YYY	.180/4.57	"C"		50μ"/1.27μ Au	50295-3YYYHCLF	YYY	.180/4.57	"C"		50μ"/1.27μ Au
50295-3YYYHD	YYY	.180/4.57	"D"	TIN-LEAD	50μ"/1.27μ Au	50295-3YYYHDLF	YYY	.180/4.57	"D"	TIN	50μ"/1.27μ Au

TABLE CONTINUED ON SHEET 5

Amphenol
FCi

Copyright AFci

mat'l. code NOTE 3				surface ISO 1302 ✓		tolerance ISO 406 ISO 1101		projection 		product family HPC					
ltr	ecn no	dr	date	tolerances unless otherwise specified								title			
S				angles		linear		INCH/MM		4 ROW R/A RECEPTACLE SOLDER TAIL, 0 GUIDE PIN					
				0°±2°		.XX±.01/.X±0.3 .XXX±.005/.XX±0.13 .XXXX±.0020/.XXX±0.051		scale 1:1		dwg no 50295					
				dr	G.PETERS	6/4/96	Amphenol FCi		sheet 4 of 5		size A3				
				enr	S.CLARK	6/3/96			type Product Customer Drawing						
				chr	S.CLARK	6/4/96									
				appd	S.CLARK	6/4/96									
sheet index	revision sheet														

PRODUCT NUMBER NOTE 1 AND 2	NUMBER OF POSITIONS SEE NOTE 2	TAIL LENGTH ±.010/0.25	SPECIAL FEATURES SEE NOTE 6	TAIL PLATING	CONTACT PLATING SEE NOTE 10
50295-5YYYE	YYY	.125/3.18	NONE	TIN/LEAD	30μ"/0.76μ GXT
50295-5YYYELF	YYY	.125/3.18	NONE	TIN	
50295-5YYYEA	YYY	.125/3.18	"A"	TIN/LEAD	
50295-5YYYEALF	YYY	.125/3.18	"A"	TIN	
50295-5YYYEB	YYY	.125/3.18	"B"	TIN/LEAD	
50295-5YYYEBLF	YYY	.125/3.18	"B"	TIN	
50295-5YYYEC	YYY	.125/3.18	"C"	TIN/LEAD	
50295-5YYYECLF	YYY	.125/3.18	"C"	TIN	
50295-5YYYED	YYY	.125/3.18	"D"	TIN/LEAD	
50295-5YYYEDLF	YYY	.125/3.18	"D"	TIN	
50295-5YYYF	YYY	.145/3.68	NONE	TIN/LEAD	
50295-5YYYFLF	YYY	.145/3.68	NONE	TIN	
50295-5YYYFB	YYY	.145/3.68	"B"	TIN/LEAD	
50295-5YYYFBLF	YYY	.145/3.68	"B"	TIN	
50295-5YYYFC	YYY	.145/3.68	"C"	TIN/LEAD	
50295-5YYYFCLF	YYY	.145/3.68	"C"	TIN	
50295-5YYYFD	YYY	.145/3.68	"D"	TIN/LEAD	
50295-5YYYFDLF	YYY	.145/3.68	"D"	TIN	
50295-5YYYH	YYY	.180/4.57	NONE	TIN/LEAD	
50295-5YYYHLF	YYY	.180/4.57	NONE	TIN	
50295-5YYYHB	YYY	.180/4.57	"B"	TIN/LEAD	
50295-5YYYHBLF	YYY	.180/4.57	"B"	TIN	
50295-5YYYHC	YYY	.180/4.57	"C"	TIN/LEAD	
50295-5YYYHCLF	YYY	.180/4.57	"C"	TIN	
50295-5YYYHD	YYY	.180/4.57	"D"	TIN/LEAD	
50295-5YYYHDLF	YYY	.180/4.57	"D"	TIN	30μ"/0.76μ GXT

Amphenol
FCI

Copyright AFCl

mat'l. code NOTE 3		surface ISO 1302 ✓	tolerance ISO 406 ISO 1101	projection 	product family HPC
ltr	ecn no	dr	date	tolerances unless otherwise specified	title 4 ROW R/A RECEPTACLE SOLDER TAIL, 0 GUIDE PIN
S				linear .XX±.01/.X±0.3 .XXX±.005/.XX±0.13 .XXXX±.0020/.XXX±0.051	
				angles 0°±2°	
		dr	G.PETERS	6/4/96	dwg no
		enr	S.CLARK	6/3/96	sheet 5 of 5
		chr	S.CLARK	6/4/96	size A3
		appd	S.CLARK	6/4/96	Amphenol FCI
sheet index	revision sheet				type Product Customer Drawing



Стандарт Электрон Связь

Мы молодая и активно развивающаяся компания в области поставок электронных компонентов. Мы поставляем электронные компоненты отечественного и импортного производства напрямую от производителей и с крупнейших складов мира.

Благодаря сотрудничеству с мировыми поставщиками мы осуществляем комплексные и плановые поставки широчайшего спектра электронных компонентов.

Собственная эффективная логистика и склад в обеспечивает надежную поставку продукции в точно указанные сроки по всей России.

Мы осуществляем техническую поддержку нашим клиентам и предпродажную проверку качества продукции. На все поставляемые продукты мы предоставляем гарантию .

Осуществляем поставки продукции под контролем ВП МО РФ на предприятия военно-промышленного комплекса России , а также работаем в рамках 275 ФЗ с открытием отдельных счетов в уполномоченном банке. Система менеджмента качества компании соответствует требованиям ГОСТ ISO 9001.

Минимальные сроки поставки, гибкие цены, неограниченный ассортимент и индивидуальный подход к клиентам являются основой для выстраивания долгосрочного и эффективного сотрудничества с предприятиями радиоэлектронной промышленности, предприятиями ВПК и научно-исследовательскими институтами России.

С нами вы становитесь еще успешнее!

Наши контакты:

Телефон: +7 812 627 14 35

Электронная почта: sales@st-electron.ru

Адрес: 198099, Санкт-Петербург,
Промышленная ул, дом № 19, литера Н,
помещение 100-Н Офис 331