

## PORTABLE CONSUMER CODEC LOW-POWER, HIGH-FIDELITY INTEGRATED CODEC

## TSCS25xx

### DESCRIPTION

The TSCS25xx is a low-power, high-fidelity integrated CODEC with 32 bit stereo playback stereo record functionality. In addition to a high-fidelity low-power CODEC, the device integrates stereo true cap-less headphone amplifiers.

The digital audio data ports (both input and output) work in both master or slave mode and supports all common formats including I2S, Left-Justified, Right-Justified and TDM as well as direct Bluetooth PCM mode.

Beyond high-fidelity for portable systems, the device offers an enriched “audio presence” through built-in audio output processing (AOP) DSP engine. The AOP supports 12 Bands of EQ, Psychoacoustic Bass and Treble enhancement, 3D stereo enhancement and Dynamic Range controller to support pro-style Multi-band Compressor/Limiter capability.

### APPLICATIONS

- **Multimedia Handsets**
- **Lightning and USB-C connected Headphones**

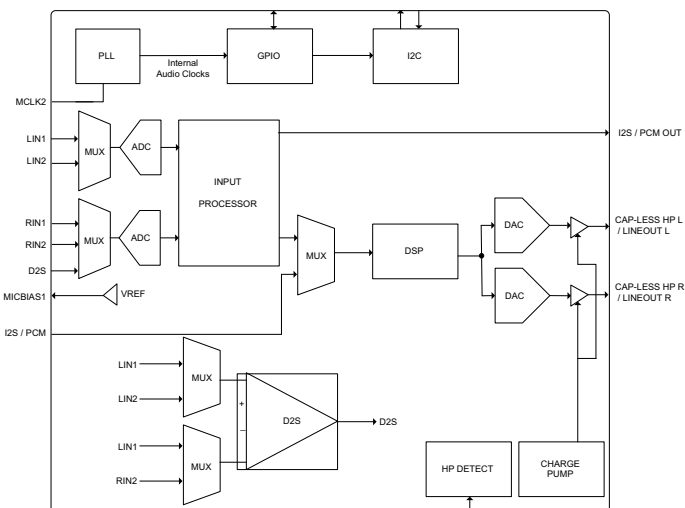

### FEATURES

- **On-chip true cap-less headphone driver**
  - 35 mW output power (16Ω)
  - 29 mW output power (32Ω)
  - Charge-pump allows true, ground-centered outputs
  - SNR (A-Weighted, no active signal) -124dB
  - Headphone detection logic
- **High fidelity CODEC**
  - 32 bit stereo DAC and 32-bit stereo ADC
  - Sample rates from 8k to 96 kHz
- **Audio Output Processing DSP Engine**
  - 3D stereo enhancement
  - 12 band parametric equalizers
  - Dynamic Range controller
    - Multi-band with independent attack/release and gain
    - Limiter
    - Expander
  - Psychoacoustic Bass and Treble enhancement processing
- **Microphone/line-in interface**
  - Analog microphone or line-in inputs
  - Automatic level control
- **Low power with built in power management**
  - 1.7 V CODEC supports 1Vrms
  - Very low standby and no-signal power consumption
  - 1.8V digital / 1.7V analog supply for low power
- **2-wire (I<sup>2</sup>C compatible) control interface**
- **I<sup>2</sup>S data interface**
  - Supports Bluetooth PCM mode
  - Left-Justified, Right-Justified, and PCM Audio Interfaces
- **Package**
  - 40-pin, 5x5mm, QFN

<b>1. OVERVIEW .....</b>	<b>6</b>
1.1. Block Diagram .....	6
1.2. Audio Outputs .....	6
1.3. Audio Inputs .....	7
<b>2. POWER MANAGEMENT .....</b>	<b>8</b>
2.1. Control Registers .....	8
2.1.1. Power Management Register 1 .....	8
2.1.2. Power Management 2 Register .....	9
2.2. Stopping the Master Clock .....	9
<b>3. OUTPUT AUDIO PROCESSING .....</b>	<b>10</b>
3.1. DC Removal .....	10
3.2. Volume Control .....	11
3.2.1. Volume Control Registers .....	12
3.3. Parametric Equalizer .....	13
3.3.1. Prescaler & Equalizer Filter .....	13
3.3.2. EQ Filter Enable Register .....	14
3.3.3. DACCRAM Write/Read Registers .....	14
3.3.3.1. DAC Coefficient Write Data Low Register .....	14
3.3.3.2. DAC Coefficient Write Data Mid Register .....	14
3.3.3.3. DAC Coefficient WRITE Data High Register .....	15
3.3.3.4. DAC Coefficient Read Data Low Register .....	15
3.3.3.5. DAC Coefficient Read Data Mid Register .....	15
3.3.3.6. DAC Coefficient Read Data High Register .....	15
3.3.4. DACCRAM Address Register .....	16
3.3.5. DACCRAM STATUS Register .....	16
3.3.6. Equalizer, Bass, Treble Coefficient & Equalizer Prescaler RAM .....	16
3.4. Gain and Dynamic Range Control .....	21
3.5. Multi-band Compressor .....	21
3.5.1. Overview .....	21
3.5.2. Multi band Compressor Registers .....	23
3.6. Limiter/Compressor/Expander .....	30
3.6.1. Overview .....	30
3.6.2. Configuration .....	31
3.6.3. Controlling parameters .....	32
3.6.4. Limiter/Compressor/Expander Registers .....	32
3.6.4.1. General compressor/limiter/expander control Register .....	32
3.6.4.2. Compressor/Limiter/Expander make-up gain Register .....	33
3.6.4.3. Compressor Threshold Register .....	33
3.6.4.4. Compressor ration register .....	33
3.6.4.5. Compressor Attack Time Constant Register (Low) .....	33
3.6.4.6. Compressor Attack Time Constant Register (High) .....	34
3.6.4.7. Compressor Release Time Constant Register (Low) .....	34
3.6.4.8. Compressor Release Time Constant Register (High) .....	34
3.6.4.9. Limiter Threshold Register .....	34
3.6.4.10. Limiter Target Register .....	35
3.6.4.11. Limiter Attack Time Constant Register (Low) .....	35
3.6.4.12. Limiter Attack Time Constant Register (High) .....	35
3.6.4.13. Limiter Release Time Constant Register (Low) .....	35
3.6.4.14. Limiter Release Time Constant Register (High) .....	36
3.6.4.15. Expander Threshold Register .....	36
3.6.4.16. Expander Ratio Register .....	36
3.6.4.17. Expander Attack Time Constant Register (Low) .....	36
3.6.4.18. Expander Attack Time Constant Register (High) .....	37
3.6.4.19. Expander Release Time Constant Register (Low) .....	37
3.6.4.20. Expander Release Time Constant Register (High) .....	37
3.7. Output Effects .....	37
3.7.1. FX Control Register .....	38
3.7.2. Stereo Depth (3-D) Enhancement .....	38
3.7.3. Psychoacoustic Bass Enhancement .....	39

3.7.4. Treble Enhancement .....	39
3.8. Mute and De-Emphasis .....	40
3.9. Mono Operation and Phase Inversion .....	40
3.9.1. DAC Control Register .....	40
3.10. Analog Outputs .....	40
3.10.1. Headphone Output .....	40
Headphone Volume Control Registers 41	
<b>4. INPUT AUDIO PROCESSING .....</b>	<b>42</b>
4.1. Analog Inputs .....	42
4.1.1. Input Software Control Register .....	43
4.2. Mono Mixing and Output Configuration .....	43
4.2.1. ADC D2S Input Mode Register .....	43
4.2.2. ADC Mono, Filter, and Inversion .....	44
4.2.3. ADC Data Output Configuration .....	44
4.3. Microphone Bias .....	44
4.3.1. Microphone Bias Control Bit .....	45
4.4. Programmable Gain Control .....	45
4.4.1. Input PGA Software Control Register .....	46
4.5. ADC Digital Filter .....	46
4.5.1. ADC Signal Path Control Register .....	47
4.5.2. ADC High Pass Filter Enable Modes .....	47
4.6. Digital ADC Volume Control .....	47
4.6.1. ADC Digital Volume Control Register .....	48
4.7. Automatic Level Control (ALC) .....	48
4.7.1. ALC Operation .....	49
4.7.2. ALC Control Register .....	50
4.7.3. Peak Limiter .....	51
4.7.4. Input Threshold .....	51
4.7.5. Noise Gate Control Register .....	51
<b>5. DIGITAL AUDIO AND CONTROL INTERFACES .....</b>	<b>52</b>
5.1. Data Interface .....	52
5.2. Master and Slave Mode Operation .....	52
5.3. Audio Data Formats .....	53
5.3.1. PCM Interface .....	53
5.3.1.1. PCM control Registers .....	55
5.3.2. Left Justified Audio Interface .....	56
5.3.3. Right Justified Audio Interface (assuming n-bit word length) .....	57
5.3.4. I2S Format Audio Interface .....	57
5.4. Audio Data Interface Registers .....	58
5.4.1. I2S Interface Control Registers .....	58
5.4.2. Audio Interface Output Tri-state .....	58
5.4.3. Bit Clock and LR Clock Mode Controls .....	59
5.4.4. ADC Output Pin State .....	61
5.4.5. Audio Interface Control 3 Register .....	61
5.4.6. Bit Clock Mode .....	61
5.5. I2C /Control Interface .....	62
5.5.1. Register Write Cycle .....	62
5.5.2. Multiple Write Cycle .....	63
5.5.3. Register Read Cycle .....	63
5.5.4. Multiple Read Cycle .....	63
5.5.5. Device Addressing and Identification .....	64
5.5.5.1. Device Address Register .....	65
5.5.5.2. Device Identification Registers .....	65
5.5.6. Device Revision Register .....	65
5.5.7. Register Reset .....	65
<b>6. GPIO'S .....</b>	<b>66</b>
6.1. GPIO Usage Summary .....	66
6.2. GPIO Control Registers .....	66
6.2.1. GPIO Control 1 Register .....	66

6.2.2. GPIO Control 2 Register .....	67
<b>7. CLOCK GENERATION .....</b>	<b>68</b>
7.1. On-Chip PLLs .....	68
7.2. System Clock Generation .....	69
7.2.1. PLL Dividers .....	69
7.2.1.1. PLL Control Register .....	73
7.2.1.2. PLL Status Register .....	73
7.2.1.3. PLL Reference Register .....	73
7.2.1.4. PLL1 Control Register .....	73
7.2.1.5. PLL1 Reference Clock Divider Register .....	74
7.2.1.6. PLL1 Output Divider Register .....	74
7.2.1.7. PLL1 Feedback Divider Low Register .....	74
7.2.1.8. PLL1 Feedback Divider High Register .....	74
7.2.1.9. PLL2 Control Register .....	75
7.2.1.10. PLL2 Reference Clock Divider Register .....	75
7.2.1.11. PLL2 Output Divider Register .....	75
7.2.1.12. PLL2 Feedback Divider Low Register .....	75
7.2.1.13. PLL2 Feedback Divider High Register .....	75
7.2.1.14. PLL Pwer DownControl Register .....	76
7.2.2. PLL Power Down Control .....	76
7.2.3. Audio Clock Generation .....	76
7.2.3.1. PLL Clock Source .....	76
7.2.3.2. Internal Sample Rate Control Register .....	77
7.2.3.3. MCLK2 Pin .....	78
7.2.3.4. I2S Master Mode Clock Generation .....	78
7.2.3.5. I2S Master Mode Sample Rate Control .....	78
7.2.3.6. DAC/ADC Clock Control .....	78
7.2.3.7. Timebase Register .....	80
<b>8. CHARACTERISTICS .....</b>	<b>81</b>
8.1. Electrical Specifications .....	81
8.1.1. Absolute Maximum Ratings .....	81
8.1.2. Recommended Operating Conditions .....	81
8.2. Device Characteristics .....	82
8.3. Electrical Characteristics .....	84
8.3.1. Low Power Mode Consumption .....	85
<b>9. REGISTER MAP .....</b>	<b>86</b>
<b>10. PIN INFORMATION .....</b>	<b>92</b>
10.1. TSCS25A3 Pin Diagram .....	92
10.2. Pin Tables .....	93
10.2.1. Power Pins .....	93
10.2.2. Reference Pins .....	93
10.2.3. Analog Input Pins .....	93
10.2.4. Analog Output Pins .....	94
10.2.5. Data and Control Pins .....	94
10.2.6. PLL Pins .....	94
10.2.7. No Connetion Pins .....	94
<b>11. PACKAGE DRAWINGS .....</b>	<b>95</b>
11.1. 40QFN Package Outline and Package Dimensions .....	95
11.2. Pb Free Process- Package Classification Reflow Temperatures .....	96
<b>12. APPLICATION INFORMATION .....</b>	<b>97</b>
<b>13. ORDERING INFORMATION .....</b>	<b>98</b>
<b>14. DISCLAIMER .....</b>	<b>99</b>
<b>15. DOCUMENT REVISION HISTORY .....</b>	<b>100</b>

# TSCS25xx

## Portable Consumer CODECs

---

Block Diagram .....	6
Output Audio Processing .....	10
Prescaler & EQ Filters .....	13
6-Tap IIR Equalizer Filter .....	13
DAC Coefficient RAM Write Sequence .....	17
DAC Coefficient RAM Read Sequence .....	18
Gain Compressor, Output vs Input .....	21
block diagram Multiband compressor .....	22
Compressor block diagram .....	22
Gain Compressor, Output vs Input .....	30
3-D Channel Inversion .....	38
Bass Enhancement .....	39
Treble Enhancement .....	39
Input Audio Processing .....	42
Mic Bias .....	45
ADC Filter Data Path .....	46
ALC Operation .....	49
Master mode .....	52
Slave mode .....	52
PCM Audio Interface .....	54
Left Justified Audio Interface (assuming n-bit word length) .....	57
Right Justified Audio Interface (assuming n-bit word length) .....	57
I2S Justified Audio Interface (assuming n-bit word length) .....	57
Bit Clock mode .....	62
2-Wire Serial Control Interface .....	62
Multiple Write Cycle .....	63
Read Cycle .....	63
Multiple Read Cycle .....	64
PLL Block Diagram .....	68
System Clock Diagram .....	69
Simplified System Clock Block Diagram .....	72
40QFN Pin Assignment .....	92
40QFN Package Diagram .....	95

# TSCS25xx

## Portable Consumer CODECs

PWRM1 Register .....	8
PWRM2 Register .....	9
Stopping the Master Clock .....	9
DCOFSEL Register .....	11
DC removal filter bypass .....	11
DACVOLL/DACVOLR Register .....	11
VUCTL Register .....	12
GAINCTL Register .....	12
CONFIG1 Registers .....	14
DACCRWRL Register .....	14
DACCRWRM Register .....	14
DACCRWRH Register .....	15
DACCRRDL Register .....	15
DACCRRDM Register .....	15
DACCRRDH Register .....	15
DACCRADDR Register .....	16
DACCRSTAT Register .....	16
Table 18: DACCRAM EQ Addresses .....	19
Table 19: DACCRAM Bass/Treble/3D and multiband compressor Addresses .....	20
DACMBCEN Register .....	23
DACMBCCTL Register .....	24
DACMBCMUG1 Register .....	24
DACMBCTHR1 Register .....	24
DACMBCRAT1 Register .....	25
DACMBCATK1L Register .....	25
DACMBCATK1H Register .....	25
DACMBCREL1L Register .....	25
DACMBCREL1H Register .....	26
DACMBCMUG2 Register .....	26
DACMBCTHR2 Register .....	26
DACMBCRAT2 Register .....	26
DACMBCATK2L Register .....	27
DACMBCATK2H Register .....	27
DACMBCREL2L Register .....	27
DACMBCREL2H Register .....	27
DACMBCMUG3 Register .....	28
DACMBCTHR3 Register .....	28
DACMBCRAT3 Register .....	28
DACMBCATK3L Register .....	28
DACMBCATK3H Register .....	29
DACMBCREL3L Register .....	29
DACMBCREL3H Register .....	29
CLECTL Register .....	32
MUGAIN Register .....	33
COMPTH Register .....	33
CMPRAT Register .....	33
CATKTCL Register .....	33
CATKTCH Register .....	34
CRELTCL Register .....	34
CRELTCH Register .....	34
LIMTH Register .....	34
LIMTGT Register .....	35
LATKTCL Register .....	35
LATKTCH Register .....	35
LRELTCL Register .....	35
LRELTCH Register .....	36
EXPTH Register .....	36
EXPRAT Register .....	36
XATKTCL Register .....	36

# TSCS25xx

## Portable Consumer CODECs

XATKTCH Register .....	37
XRELTCL Register .....	37
XRELTCH Register .....	37
FXCTL Register .....	38
CNVRTR1 Register .....	40
HPVOL L/R Registers .....	41
INSELL and INSLR Register .....	43
INMODE Register .....	43
CNVRTR0 Register .....	44
AIC2 Register .....	44
Mic Bias Enable .....	45
INVOLL/ INVOLR Register .....	46
CNVRTR0 Register .....	47
ADC HPF Enable .....	47
ADCVOLL/ADCVOLR Register .....	48
ALC0/1/2/3 Registers .....	50
NGATE Register .....	51
ADPCMCTL1 Register .....	55
ADPCMCTL2 Register .....	55
DACPCMCTL1 Register .....	56
DACPCMCTL2 Register .....	56
AIC1 Register .....	58
AIC2 Register .....	59
Bit Clock and LR Clock Mode Selection .....	60
ADC Data Output pin state .....	61
AIC3 Register .....	61
ADCSR/ DACSR Register .....	61
DEVADRI Register .....	65
DEVID H&L Registers .....	65
REVID Register .....	65
RESET Register .....	65
GPIO Pin Usage Summary .....	66
GPIOCTL1 Register .....	66
GPIOCTL2 Register .....	67
Typical PLL Divider Value .....	71
PLLCTL1B Register .....	73
PLLCTL0 Register .....	73
PLLREFSEL Register .....	73
PLLCTLD Register .....	73
PLLCTL9 Register .....	74
PLLCTLA Register .....	74
PLLCTLB Register .....	74
PLLCTLC Register .....	74
PLLCTL12 Register .....	75
PLLCTLE Register .....	75
PLLCTLF Register .....	75
PLLCTL10 Register .....	75
PLLCTL11 Register .....	75
PLLCTL1C Register .....	76
ADCSR Register .....	77
DACSR Register .....	77
DAC/ADC Sample rates .....	78
CONFIG0 Register .....	79
ADC and DAC Modulator Rates .....	80
TIMEBASE Register .....	80
Electrical Specification: Maximum Ratings .....	81
Recommended Operating Conditions .....	81
Device Characteristics .....	82
PLL Section DC Characteristics .....	84

# TSCS25xx

## Portable Consumer CODECs

---

Low Power Mode Consumption .....	85
Register Map .....	91
Power Pins .....	93
Reference Pins .....	93
Analog Input Pins .....	93
Analog Output Pins .....	94
Data and Control Pins .....	94
PLL Pins .....	94
PLL Pins .....	94
Reflow Temperatures .....	96



**1. OVERVIEW**

**1.1. Block Diagram**

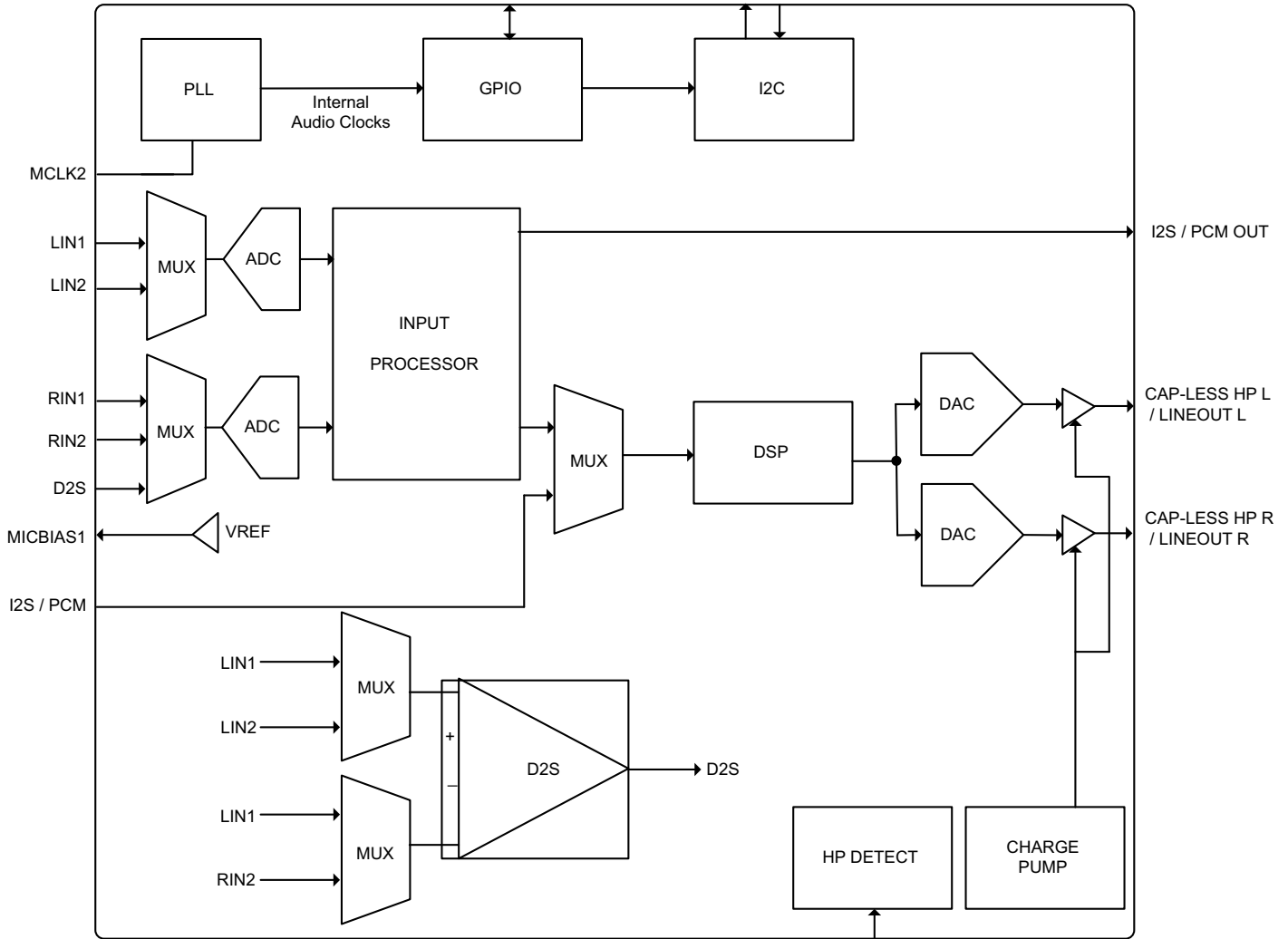

**Figure 1. Block Diagram**

**1.2. Audio Outputs**

The TSCS25xx provides :

- A line-out/cap less stereo headphone port with ground referenced outputs, capable of driving headphones without requiring an external DC blocking capacitor.

Each endpoint features independent volume controls, including a soft-mute capability which can slowly ramp up or down the volume changes to avoid unwanted audio artifacts.

The TSCS25xx output signal paths consist of digital filters, DACs and output drivers. The digital filters and DACs are enabled when the TSCS25xx is in 'playback only' or 'record and playback' mode. The output drivers can be separately

## TSCS25xx

### Portable Consumer CODECs

---

enabled by individual control bits.

The digital filter and audio processing block processes the data to provide volume control and numerous sound enhancement algorithms. Two high performance sigma-delta audio DACs convert the digital data into analog. The digital audio data is converted to over sampled bit streams using digital interpolation filters, which then enters sigma-delta DACs, and become converted to high quality analog audio signals.

### 1.3. Audio Inputs

The TSCS25XX provides multiple digital and analog audio inputs. Audio inputs include

- One digital audio input
  - support all common I2S formats as well as direct Bluetooth PCM mode
- Three mux selectable stereo analog line/microphone inputs with selectable differential input option

The device provides input gain control, separate volume controls, automatic leveling capability, and programmable microphone boost to smooth input recording. A programmable silence/noise gate “floor” or “threshold” can be set to minimize background noise.

## 2. POWER MANAGEMENT

### 2.1. Control Registers

The TSCS42XX has control registers to enable system software to control which functions are active. To minimize power consumption, unused functions should be disabled. To avoid audio artifacts, it is important to enable or disable functions in the correct order. Depending on user case, customer can contact tempo for information.

#### 2.1.1. Power Management Register 1

Register Address	Bit	Label	Type	Default	Description
R26(1Ah) PWRM1	7	BSTL	RW	0	Analog in Boost Left 0 = Power down 1 = Power up
	6	BSTR	RW	0	Analog in Boost Right 0 = Power down 1 = Power up
	5	PGAL	RW	0	Analog in PGA Left 0 = Power down 1 = Power up
	4	PGAR	RW	0	Analog in PGA Right 0 = Power down 1 = Power up
	3	ADCL	RW	0	ADC Left 0 = Power down 1 = Power up
	2	ADCR	RW	0	ADC Right 0 = Power down 1 = Power up
	1	MICB	RW	0	MICBIAS 0 = Power down 1 = Power up
	0	DIGENB	RW	0	Master clock disable 0: master clock enabled 1: master clock disabled

Table 1. PWRM1 Register

### 2.1.2. Power Management 2 Register

Register Address	Bit	Label	Type	Default	Description
R27(1Bh) PWRM2	7	D2S	RW	0	Analog in D2S AMP 0 = Power down 1 = Power up
	6	HPL	RW	0	LHP Output Buffer + DAC 0 = Power down 1 = Power up
	5	HPR	RW	0	RHP Output Buffer + DAC 0 = Power down 1 = Power up
	4	SPKL	RW	0	LSPK Output Buffer 0 = Power down 1 = Power up
	3	SPKR	RW	0	RSPK Output Buffer 0 = Power down 1 = Power up
	2	RSVD	RW	0	Reserved(bit implemented but unused)
	1	RSVD	RW	0	Reserved (bit implemented bur unused)
	0	VREF	RW	0	VREF (necessary for all other functions) 0 = Power down 1 = Power up

Table 2. PWRM2 Register

## 2.2. Stopping the Master Clock

In order to minimize digital core power consumption, the master clock may be stopped in Standby and OFF modes by setting the DIGENB bit (R26, bit 0).

Register Address	Bit	Label	Type	Default	Description
R26(1Ah) PWRM1	0	DIGENB	RW	0	Master clock disable 0: master clock enabled 1: master clock disabled

Table 3. Stopping the Master Clock

**Note:** The control bits ADCL, ADCR, HPL and HPR must be set to zero for 100ms before DIGENB is set. It is recommended that during development, the developer should endeavor to observe HPL and HPR ports ramp down completely. Failure to follow this procedure may cause pops or if the wait period is less than 1mS, may prevent the DACs and ADCs from re-starting correctly.

### 3. OUTPUT AUDIO PROCESSING

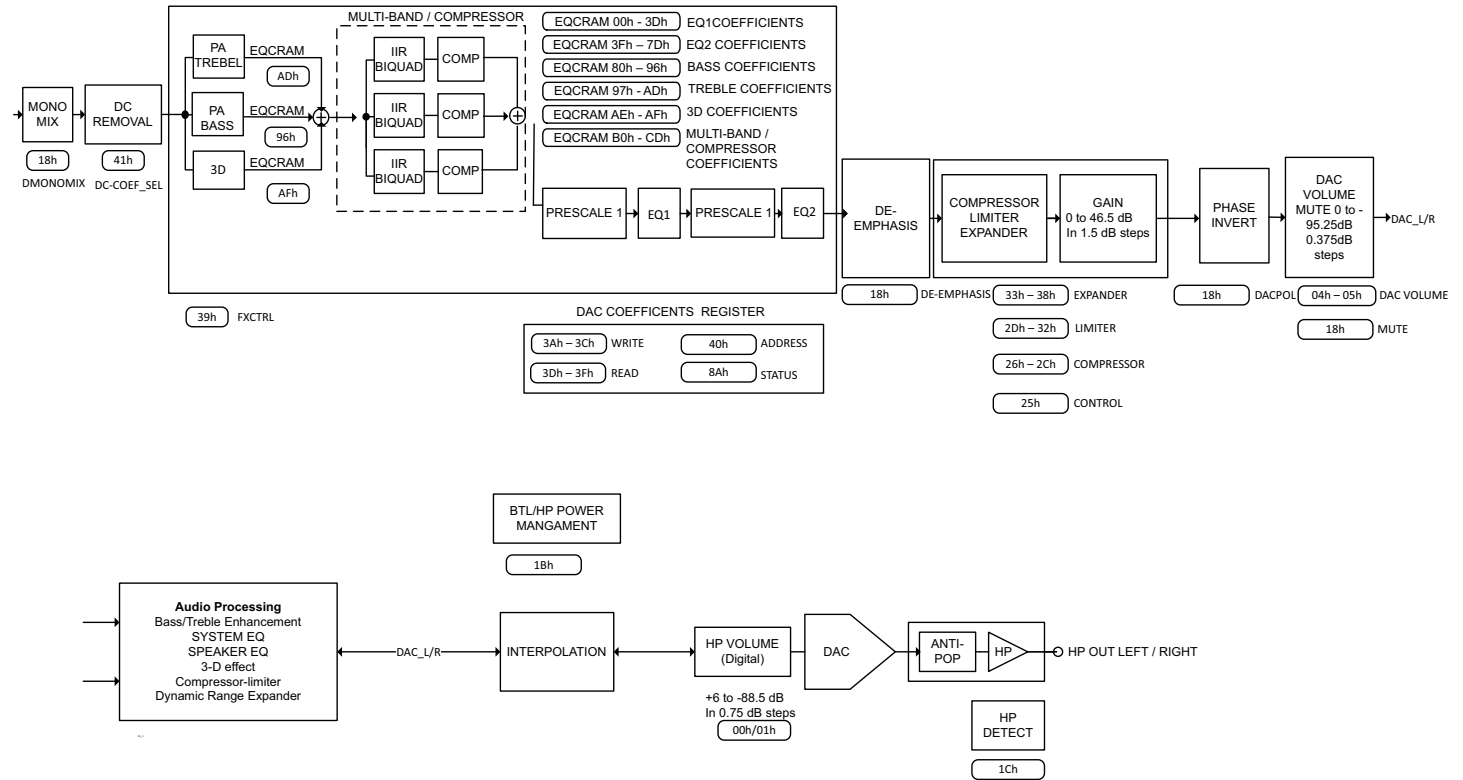

Figure 2. Output Audio Processing

#### 3.1. DC Removal

Before processing, a DC removal filter removes the DC component from the incoming audio data. The DC removal filter is programmable, and can be bypassed by setting dc\_bypass bit (R31 CONFIG0, bit1). The DC removal is active by default.

Register Address	Bit	Label	Type	Default	Description
R65 (41h) DCOFSEL	7:3	–	R	0	Reserved for future use.
	2:0	-	RW	5	0: dc_coef = 24'h008000; //2 <sup>8</sup> -8 1: dc_coef = 24'h004000; //2 <sup>8</sup> -9 2: dc_coef = 24'h002000; //2 <sup>8</sup> -10 3: dc_coef = 24'h001000; //2 <sup>8</sup> -11 4: dc_coef = 24'h000800; //2 <sup>8</sup> -12 5: dc_coef = 24'h000400; //2 <sup>8</sup> -13 6: dc_coef = 24'h000200; //2 <sup>8</sup> -14 7: dc_coef = 24'h000100; //2 <sup>8</sup> -15

Table 4. DCOFSEL Register

Register Address	Bit	Label	Type	Default	Description
R31 (1Fh) CONFIG0	1	dc_bypass	RW	0	1 = bypass DC removal filter 0 = DC removal filter active

Table 5. DC removal filter bypass

### 3.2. Volume Control

The signal volume can be controlled digitally, across a gain and attenuation range of -95.25dB to 0dB (0.375dB steps). The level of attenuation is specified by an eight-bit code, 'DACVOL\_x', where 'x' is L, or R. The value "00000000" indicates mute; other values select the number of 0.375dB steps above -95.625dB for the volume level.

The Volume Update bits control the updating of volume control data; when a bit is written as '0', the Left Volume control associated with that bit is updated when ever the left volume register is written and the Right Volume control is updated when ever the right volume register is written. When a bit is written as '1', the left volume data is placed into an internal holding register when the left volume register is written and both the left and right volumes are updated when the right volume register is written. This enables a simultaneous left and right volume update.

Register Address	Bit	Label	Type	Default	Description
R4 (04h) DACVOLL	7:0	DACVOL_L [7:0]	RW	FF (0dB)	Left DAC Volume Level 0000 0000 = Digital Mute 0000 0001 = -95.25dB 0000 0010 = -94.875dB ... 0.375dB steps up to 1111 1111 = 0dB Note: If DACVOLU is set, this setting will take effect after the next write to the Right Input Volume register.
R5 (05h) DACVOLRI	7:0	DACVOL_R [7:0]	RW	FF (0dB)	Right DAC Digital Volume Level 0000 0000 = Digital Mute 0000 0001 = -95.25dB 0000 0010 = -94.875dB ... 0.375dB steps up to 1111 1111 = 0dB

Table 6. DACVOLL/DACVOLR Register

### 3.2.1. Volume Control Registers

Register Address	Bit	Label	Type	Default	Description
R10 (0Ah) VUCTL	7	ADCFade	RW	1	1 = volume fades between old/new value 0 = volume/mute changes immediately
	6	DACFade	RW	1	1 = volume fades between old/new value 0 = volume/mute changes immediately
	5	RSVD	R	0	Reserved for future use.
	4	INVOLU	RW	0	0 = Left input volume updated immediately 1 = Left input volume held until right input volume register written.
	3	ADCVOLU	RW	0	0 = Left ADC volume updated immediately 1 = Left ADC volume held until right ADC volume register written.
	2	DACVOLU	RW	0	0 = Left DAC volume updated immediately 1 = Left DAC volume held until right DAC volume register written.
	1	SPKVOLU	RW	0	0 = Left speaker volume updated immediately 1 = Left speaker volume held until right speaker volume register written.
	0	HPVOLU	RW	0	0 = Left headphone volume updated immediately 1 = Left headphone volume held until right headphone volume register written.

**Table 7. VUCTL Register**

The output path may be muted automatically when a long string of zero data is received. The length of zeros is programmable and a detection flag indicates when a stream of zero data has been detected.

Register Address	Bit	Label	Type	Default	Description
R33 (21h) GAINCTL	7	zerodet_flag	R	0	1 = zero detect length exceeded.
	6	RSVD	R	0	Reserved for future use.
	5:4	zerodetlen	RW	2	Enable mute if input consecutive zeros exceeds this length. 0 = 512, 1 = 1k, 2 = 2k, 3 = 4k samples
	3	auto_pwr	R	0	power down when mute detected
	2	auto_mute	RW	1	1 = auto mute if detect long string of zeros on input
	1	RSVD	R	0	Reserved for future use.
	0	RSVD	R	0	Reserved for future use.

**Table 8. GAINCTL Register**

### 3.3. Parametric Equalizer

The TSCS42XX has a 12-band digital parametric equalizer (a dual 6-band parametric equalizer: EQ1 and EQ2) to enable fine tuning of the audio response and preferences for a given system. Each EQ may be enabled or disabled independently.

#### 3.3.1. Prescaler & Equalizer Filter

The dual 6-band parametric equalizer consists of a Prescaler and 6 cascaded 6-tap IIR Filters. The Prescaler allows the input to be attenuated prior to the EQ filters in case the EQ filters introduce gain, and would thus clip if not prescaled.

Tempo provides a tool to enable an audio designer to determine appropriate coefficients for the equalizer filters. The filters enable the implementation of a 6-band parametric equalizer with selectable frequency bands, gain, and filter characteristics (high, low, or bandpass)

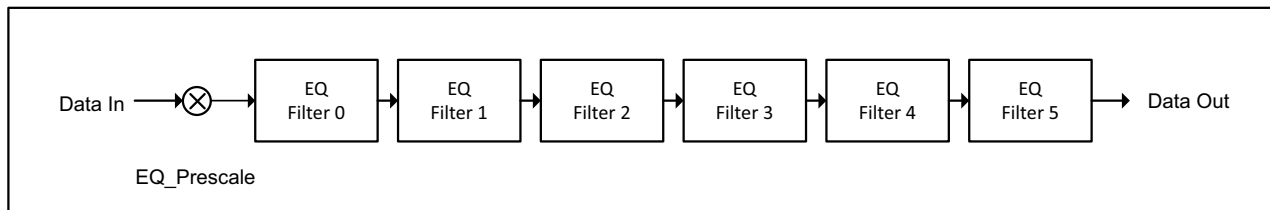

Figure 3. Prescaler & EQ Filters

The figure below shows the structure of a single EQ filter. The  $a(0)$  tap is always normalized to be equal to 1 (400000h). The remaining 5 taps are 24-bit twos complement format programmable coefficients. ( $-2 < \text{coefficient} < +2$ )

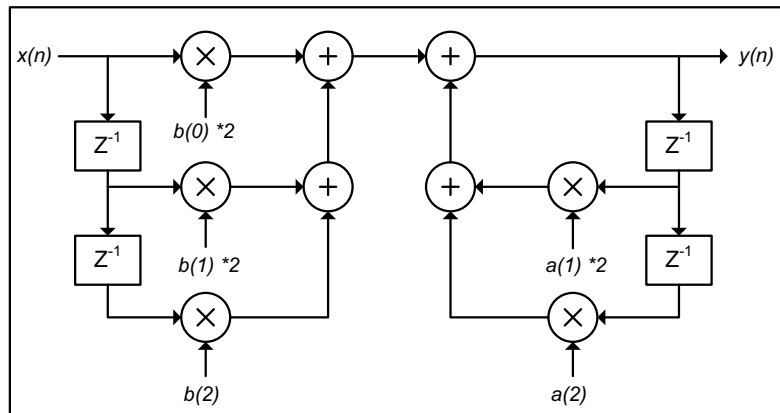

Figure 4. 6-Tap IIR Equalizer Filter



### 3.3.2. EQ Filter Enable Register

Register Address	Bit	Label	Type	Default	Description
R32 (20h) CONFIG1	7	EQ2_EN	R/W	0	EQ bank 2 enable 0 = second EQ bypassed 1 = second EQ enabled
	6:4	EQ2_BE[2:0]	R/W	0	EQ2 band enable. When the EQ is enabled the following EQ stages are executed. 0 - Prescale only 1 - Prescale and Filter Band 0 ... 6 - Prescale and Filter Bands 0 to 5 7 - RESERVED
	3	EQ1_EN	R/W	0	EQ bank 1 enable 0 = first EQ bypassed 1 = first EQ enabled
	2:0	EQ1_BE[2:0]	R/W	0	EQ1 band enable. When the EQ is enabled the following EQ stages are executed. 0 - Prescale only 1 - Prescale and Filter Band 0 ... 6 - Prescale and Filter Bands 0 to 5 7 - RESERVED

Table 9. CONFIG1 Registers

### 3.3.3. DACCRAM Write/Read Registers

Below registers provide the 24-bit data holding registers used when doing indirect writes/reads to the DAC Coefficient RAM.

#### 3.3.3.1. DAC Coefficient Write Data Low Register

Register Address	Bit	Label	Type	Default	Description
R58 (3Ah) DACCRWRL	7:0	DACCRWD[7:0]	R/W	0	Low byte of a 24-bit data register, contains the values to be written to the DACCRAM. The address written will have be specified by the DACCRAM Address fields.

Table 10. DACCRWRL Register

#### 3.3.3.2. DAC Coefficient Write Data Mid Register

Register Address	Bit	Label	Type	Default	Description
R59 (3Bh) DACCRWRM	7:0	DACCRWD[15:8]	R/W	0	Middle byte of a 24-bit data register, contains the values to be written to the DACCRAM. The address written will have be specified by the DACCRAM Address fields.

Table 11. DACCRWRM Register

3.3.3.3. *DAC Coefficient WRITE Data High Register*

Register Address	Bit	Label	Type	Default	Description
R60 (3Ch) DACCRWRH	7:0	DACCRWD[23:16]	R/W	0	High byte of a 24-bit data register, contains the values to be written to the DACCRAM. The address written will have be specified by the DACCRAM Address fields.

Table 12. DACCRWRH Register

3.3.3.4. *DAC Coefficient Read Data Low Register*

Register Address	Bit	Label	Type	Default	Description
R61 (3Dh) DACCRDL	7:0	DACCRRD[7:0]	R	0	Low byte of a 24-bit data register, contains the contents of the most recent DACCRAM address read from the RAM. The address read will have been specified by the DACCRAM Address fields.

Table 13. DACCRDL Register

3.3.3.5. *DAC Coefficient Read Data Mid Register*

Register Address	Bit	Label	Type	Default	Description
R62 (3Eh) DACRRDM	7:0	DACCRRD[15:8]	R	0	Middle byte of a 24-bit data register, contains the contents of the most recent DACCRAM address read from the RAM. The address read will have been specified by the DACCRAM Address fields.

Table 14. DACRRDM Register

3.3.3.6. *DAC Coefficient Read Data High Register*

Register Address	Bit	Label	Type	Default	Description
R63 (3Fh) DACRRDH	7:0	DACCRRD[23:16 ]	R	0	High byte of a 24-bit data register, contains the contents of the most recent DACCRAM address read from the RAM. The address read will have been specified by the DACCRAM Address fields.

Table 15. DACRRDH Register

### 3.3.4. DACCRAM Address Register

This 8-bit register provides the address to the internal RAM when doing indirect writes/reads to the DAC Coefficient RAM

Register Address	Bit	Label	Type	Default	Description
R64 (40h) DACCRADDR	7:0	DACCRADD	R/W	0	Contains the address (between 0 and 255) of the DACCRAM to be accessed by a read or write. This is not a byte address--it is the address of the 24-bit data item to be accessed from the DACCRAM. This address is automatically incremented after writing to DACCRAM_WRITE_HI or reading from DACCRAM_READ_HI (and the 24 bit data from the next RAM location is fetched.)

Table 16. DACCRADDR Register

### 3.3.5. DACCRAM STATUS Register

This control register provides the write/read enable when doing indirect writes/reads to the DAC Coefficient RAM.

Register Address	Bit	Label	Type	Default	Description
R138 (8Ah) DACCRSTAT	7	DACCRAM_Busy	R	0	1 = read/write to DACCRAM in progress, cleared by HW when done.
	6:0	RSVD	R	0	Reserved

Table 17. DACCRSTAT Register

### 3.3.6. Equalizer, Bass, Treble Coefficient & Equalizer Prescaler RAM

The DAC Coefficient RAM is a single port 176x24 synchronous RAM. It is programmed indirectly through the Control Bus in the following manner as shown in the figure below:

- 1 Write target address to DACCRAM\_ADDR register. (DAC Coefficient data is pre-fetched even if we don't use it)
  - a Start command followed by the Device Address and Write flag
  - b Register Address (DACCRAM\_ADDR register address)
  - c Register Data (DACCRAM address to be held in DACCRAM\_ADDR)
- 2 Start a multiple write cycle
  - a Start command followed by the Device Address and Write Flag
  - b Register Address of the DACCRAM\_WRITE\_LO register
  - c Write D7:0 to the DACCRAM\_WRITE\_LO register
  - d Write D15:8 to the DACCRAM\_WRITE\_MID register
  - e Write D23:16 to the DACCRAM\_WRITE\_HI register
- 3 On successful receipt of the DACCRAM\_WRITE\_HI data, the part will automatically start a write cycle. The DACCRAM\_Busy bit will be set high to indicate that a write is in progress.
- 4 On completion of the internal write cycle, the DACCRAM\_Busy bit will be 0 (when operating the control interface at high speeds software must poll this bit to ensure the write cycle is complete before starting another write cycle.)

# TSCS25xx

## Portable Consumer CODECs

5 The bus cycle may be terminated by the host or steps 2-3 may be repeated for writes to consecutive DAC Coefficient RAM locations.

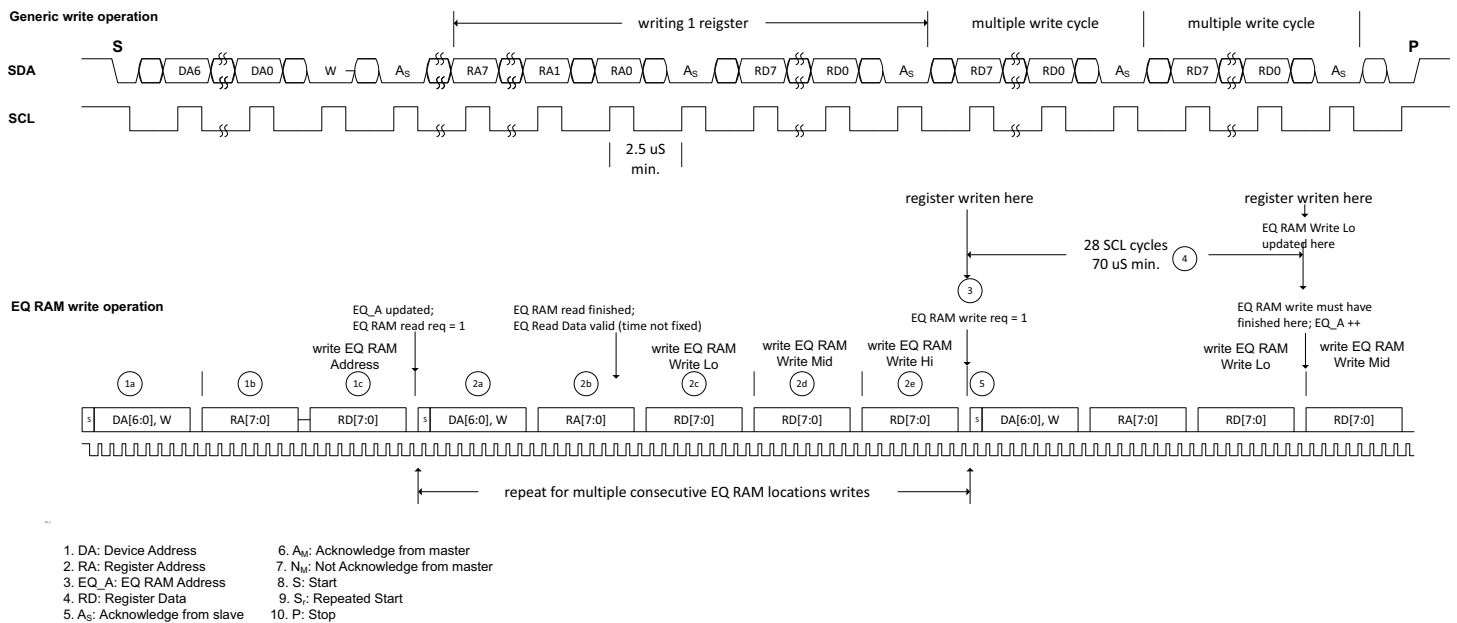

**Figure 5. DAC Coefficient RAM Write Sequence**

Reading back a value from the DACRAM is done in this manner:

- 1 Write target address to DACRAM\_ADDR register.(DAC Coefficient data is pre-fetched for read even if we don't use it)
  - a Start command followed by the Device Address and Write flag
  - b Register Address (DACRAM\_ADDR register address)
  - c Register Data (DACRAM address to be held in DACRAM\_ADDR)
- 2 Start (or repeat start) a write cycle to DACRAM\_READ\_LO and after the second byte (register address) is acknowledged, go to step 3. (Do not complete the write cycle.)
  - a Start command followed by the Device Address and Write Flag
  - b Register Address of the DACRAM\_READ\_LO register
- 3 Signal a repeat start, provide the device address, and indicate a read operation
- 4 Read D7:0 (register address incremented after ack by host)
- 5 Read D15:8 (register address incremented after ack by host)
- 6 Read D23:16 (register address incremented and next DAC Coefficient location pre-fetched after ack by host)
- 7 The host stops the bus cycle

To repeat a read cycle for consecutive DAC Coefficient RAM locations:

- 8 Start (or repeat start instead of stopping the bus cycle in step 7) a write cycle indicating DACRAM\_RD\_LO as the target address.
- 9 After the second byte is acknowledged, signal a repeated start.
- 10 Indicate a read operation
- 11 Read the DACRAM\_READ\_LO register as described in step 4
- 12 Read the DACRAM\_READ\_MID register as described in step 5

# TSCS25xx

## Portable Consumer CODECs

- 13 Read the DACRAM\_READ\_HI register as described in step 6
- 14 Repeat steps 8-13 as desired

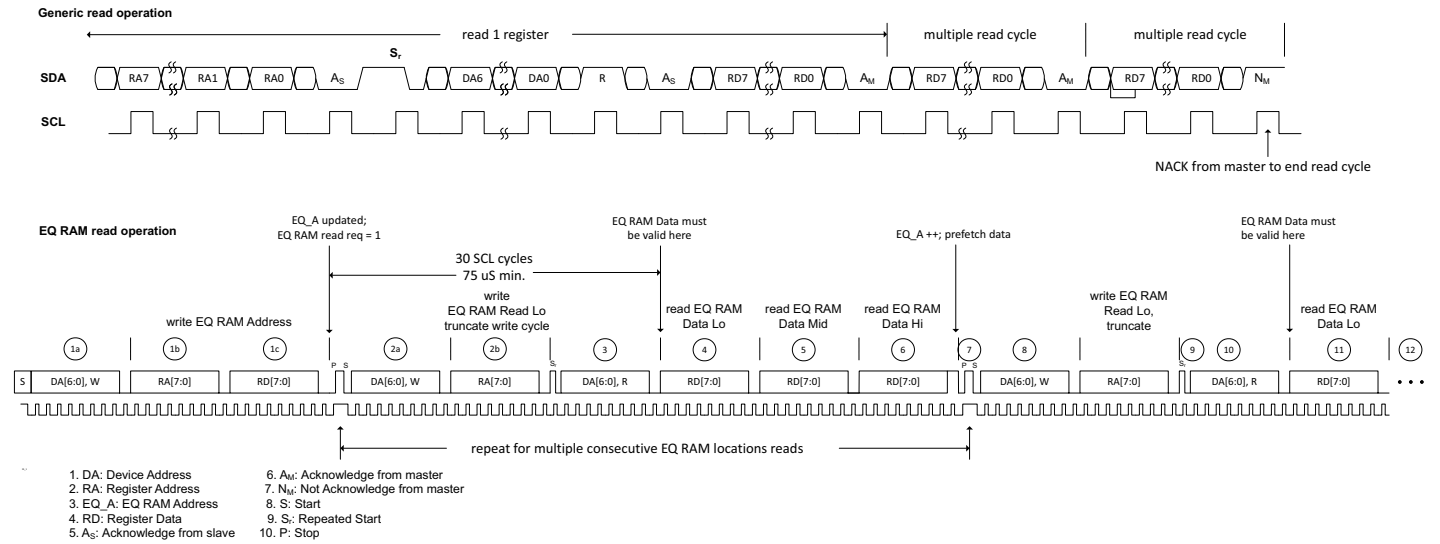

Figure 6. DAC Coefficient RAM Read Sequence

**Table 18: DACCRAM EQ Addresses**

EQ 1				EQ2			
Addr	Channel 0 Coefficients	Addr	Channel 1 Coefficients	Addr	Channel 0 Coefficients	Addr	Channel 1 Coefficients
0x00	EQ_COEF_0F0_B0	0x20	EQ_COEF_1F0_B0	0x40	EQ_COEF_2F0_B0	0x60	EQ_COEF_3F0_B0
0x01	EQ_COEF_0F0_B1	0x21	EQ_COEF_1F0_B1	0x41	EQ_COEF_2F0_B1	0x61	EQ_COEF_3F0_B1
0x02	EQ_COEF_0F0_B2	0x22	EQ_COEF_1F0_B2	0x42	EQ_COEF_2F0_B2	0x62	EQ_COEF_3F0_B2
0x03	EQ_COEF_0F0_A1	0x23	EQ_COEF_1F0_A1	0x43	EQ_COEF_2F0_A1	0x63	EQ_COEF_3F0_A1
0x04	EQ_COEF_0F0_A2	0x24	EQ_COEF_1F0_A2	0x44	EQ_COEF_2F0_A2	0x64	EQ_COEF_3F0_A2
0x05	EQ_COEF_0F1_B0	0x25	EQ_COEF_1F1_B0	0x45	EQ_COEF_2F1_B0	0x65	EQ_COEF_3F1_B0
0x06	EQ_COEF_0F1_B1	0x26	EQ_COEF_1F1_B1	0x46	EQ_COEF_2F1_B1	0x66	EQ_COEF_3F1_B1
0x07	EQ_COEF_0F1_B2	0x27	EQ_COEF_1F1_B2	0x47	EQ_COEF_2F1_B2	0x67	EQ_COEF_3F1_B2
0x08	EQ_COEF_0F1_A1	0x28	EQ_COEF_1F1_A1	0x48	EQ_COEF_2F1_A1	0x68	EQ_COEF_3F1_A1
0x09	EQ_COEF_0F1_A2	0x29	EQ_COEF_1F1_A2	0x49	EQ_COEF_2F1_A2	0x69	EQ_COEF_3F1_A2
0x0A	EQ_COEF_0F2_B0	0x2A	EQ_COEF_1F2_B0	0x4A	EQ_COEF_2F2_B0	0x6A	EQ_COEF_3F2_B0
0x0B	EQ_COEF_0F2_B1	0x2B	EQ_COEF_1F2_B1	0x4B	EQ_COEF_2F2_B1	0x6B	EQ_COEF_3F2_B1
0x0C	EQ_COEF_0F2_B2	0x2C	EQ_COEF_1F2_B2	0x4C	EQ_COEF_2F2_B2	0x6C	EQ_COEF_3F2_B2
0x0D	EQ_COEF_0F2_A1	0x2D	EQ_COEF_1F2_A1	0x4D	EQ_COEF_2F2_A1	0x6D	EQ_COEF_3F2_A1
0x0E	EQ_COEF_0F2_A2	0x2E	EQ_COEF_1F2_A2	0x4E	EQ_COEF_2F2_A2	0x6E	EQ_COEF_3F2_A2
0x0F	EQ_COEF_0F3_B0	0x2F	EQ_COEF_1F3_B0	0x4F	EQ_COEF_2F3_B0	0x6F	EQ_COEF_3F3_B0
0x10	EQ_COEF_0F3_B1	0x30	EQ_COEF_1F3_B1	0x50	EQ_COEF_2F3_B1	0x70	EQ_COEF_3F3_B1
0x11	EQ_COEF_0F3_B2	0x31	EQ_COEF_1F3_B2	0x51	EQ_COEF_2F3_B2	0x71	EQ_COEF_3F3_B2
0x12	EQ_COEF_0F3_A1	0x32	EQ_COEF_1F3_A1	0x52	EQ_COEF_2F3_A1	0x72	EQ_COEF_3F3_A1
0x13	EQ_COEF_0F3_A2	0x33	EQ_COEF_1F3_A2	0x53	EQ_COEF_2F3_A2	0x73	EQ_COEF_3F3_A2
0x14	EQ_COEF_0F4_B0	0x34	EQ_COEF_1F4_B0	0x54	EQ_COEF_2F4_B0	0x74	EQ_COEF_3F4_B0
0x15	EQ_COEF_0F4_B1	0x35	EQ_COEF_1F4_B1	0x55	EQ_COEF_2F4_B1	0x75	EQ_COEF_3F4_B1
0x16	EQ_COEF_0F4_B2	0x36	EQ_COEF_1F4_B2	0x56	EQ_COEF_2F4_B2	0x76	EQ_COEF_3F4_B2
0x17	EQ_COEF_0F4_A1	0x37	EQ_COEF_1F4_A1	0x57	EQ_COEF_2F4_A1	0x77	EQ_COEF_3F4_A1
0x18	EQ_COEF_0F4_A2	0x38	EQ_COEF_1F4_A2	0x58	EQ_COEF_2F4_A2	0x78	EQ_COEF_3F4_A2
0x19	EQ_COEF_0F5_B0	0x39	EQ_COEF_1F5_B0	0x59	EQ_COEF_2F5_B0	0x79	EQ_COEF_3F5_B0
0x1A	EQ_COEF_0F5_B1	0x3A	EQ_COEF_1F5_B1	0x5A	EQ_COEF_2F5_B1	0x7A	EQ_COEF_3F5_B1
0x1B	EQ_COEF_0F5_B2	0x3B	EQ_COEF_1F5_B2	0x5B	EQ_COEF_2F5_B2	0x7B	EQ_COEF_3F5_B2
0x1C	EQ_COEF_0F5_A1	0x3C	EQ_COEF_1F5_A1	0x5C	EQ_COEF_2F5_A1	0x7C	EQ_COEF_3F5_A1
0x1D	EQ_COEF_0F5_A2	0x3D	EQ_COEF_1F5_A2	0x5D	EQ_COEF_2F5_A2	0x7D	EQ_COEF_3F5_A2
0x1E	-	0x3E	-	0x5E	-	0x7E	-
0x1F	EQ_PRESCALE0	0x3F	EQ_PRESCALE1	0x5F	EQ_PRESCALE2	0x7F	EQ_PRESCALE3

**Table 19: DACCRAM Bass/Treble/3D and multiband compressor Addresses**

Addr	Bass	Addr	Treble	Addr	3D	Addr	Multiband
	Coefficients		Coefficients		Coefficients		Coefficients
0x80	BASS_COEF_EXT1_B0	0x97	TREB_COEF_EXT1_B0	0xAE	3D_COEF	0xB0	MBC1_BQ1_COEFF0
0x81	BASS_COEF_EXT1_B1	0x98	TREB_COEF_EXT1_B1	0xAF	3D_MIX	0xB1	MBC1_BQ1_COEFF1
0x82	BASS_COEF_EXT1_B2	0x99	TREB_COEF_EXT1_B2			0xB2	MBC1_BQ1_COEFF2
0x83	BASS_COEF_EXT1_A1	0x9A	TREB_COEF_EXT1_A1			0xB3	MBC1_BQ1_COEFF3
0x84	BASS_COEF_EXT1_A2	0x9B	TREB_COEF_EXT1_A2			0xB4	MBC1_BQ1_COEFF4
0x85	BASS_COEF_EXT2_B0	0x9C	TREB_COEF_EXT2_B0			0xB5	MBC1_BQ2_COEFF0
0x86	BASS_COEF_EXT2_B1	0x9D	TREB_COEF_EXT2_B1			0xB6	MBC1_BQ2_COEFF1
0x87	BASS_COEF_EXT2_B2	0x9E	TREB_COEF_EXT2_B2			0xB7	MBC1_BQ2_COEFF2
0x88	BASS_COEF_EXT2_A1	0x9F	TREB_COEF_EXT2_A1			0xB8	MBC1_BQ2_COEFF3
0x89	BASS_COEF_EXT2_A2	0xA0	TREB_COEF_EXT2_A2			0xB9	MBC1_BQ2_COEFF4
0x8A	BASS_COEF_NLF_M1	0xA1	TREB_COEF_NLF_M1			0xBA	MBC2_BQ1_COEFF0
0x8B	BASS_COEF_NLF_M2	0xA2	TREB_COEF_NLF_M2			0xBB	MBC2_BQ1_COEFF1
0x8C	BASS_COEF_LMT_B0	0xA3	TREB_COEF_LMT_B0			0xBC	MBC2_BQ1_COEFF2
0x8D	BASS_COEF_LMT_B1	0xA4	TREB_COEF_LMT_B1			0xBD	MBC2_BQ1_COEFF3
0x8E	BASS_COEF_LMT_B2	0xA5	TREB_COEF_LMT_B2			0xBE	MBC2_BQ1_COEFF4
0x8F	BASS_COEF_LMT_A1	0xA6	TREB_COEF_LMT_A1			0xBF	MBC2_BQ2_COEFF0
0x90	BASS_COEF_LMT_A2	0xA7	TREB_COEF_LMT_A2			0xC0	MBC2_BQ2_COEFF1
0x91	BASS_COEF_CTO_B0	0xA8	TREB_COEF_CTO_B0			0xC1	MBC2_BQ2_COEFF2
0x92	BASS_COEF_CTO_B1	0xA9	TREB_COEF_CTO_B1			0xC2	MBC2_BQ2_COEFF3
0x93	BASS_COEF_CTO_B2	0xAA	TREB_COEF_CTO_B2			0xC3	MBC2_BQ2_COEFF4
0x94	BASS_COEF_CTO_A1	0xAB	TREB_COEF_CTO_A1			0xC4	MBC3_BQ1_COEFF0
0x95	BASS_COEF_CTO_A2	0xAC	TREB_COEF_CTO_A2			0xC5	MBC3_BQ1_COEFF1
0x96	BASS_MIX	0xAD	TREB_MIX			0xC6	MBC3_BQ1_COEFF2
						0xC7	MBC3_BQ1_COEFF3
						0xC8	MBC3_BQ1_COEFF4
						0xC9	MBC3_BQ2_COEFF0
						0xCA	MBC3_BQ2_COEFF1
						0xCB	MBC3_BQ2_COEFF2
						0xCC	MBC3_BQ2_COEFF3
						0xCD	MBC3_BQ2_COEFF4

1. All B0 coefficients are set to unity (400000h) by default. All others, including M1 and M2, are 0 by default.
2. NLF coefficients (M1, M2) have a range defined as +/-8, with 1 sign bit, 3 integer bits, and 20 fraction bits. So, unity for these values is 100000h. This is as opposed to the rest of the coefficient RAM, which has a range defined as +/-2, with 1 sign bit, 1 integer bit, and 22 fraction bits.

### 3.4. Gain and Dynamic Range Control

The volume for a given channel is controlled by the DACVOL and HPVOL registers. If the result of the gain multiply step would result in overflow of the output word width, the output is saturated at the max positive or negative value. In addition to simple gain control, the TSCS25xx also provides sophisticated dynamic range control including limiting, dynamic range compression, and dynamic range expansion functions.

### 3.5. Multi-band Compressor

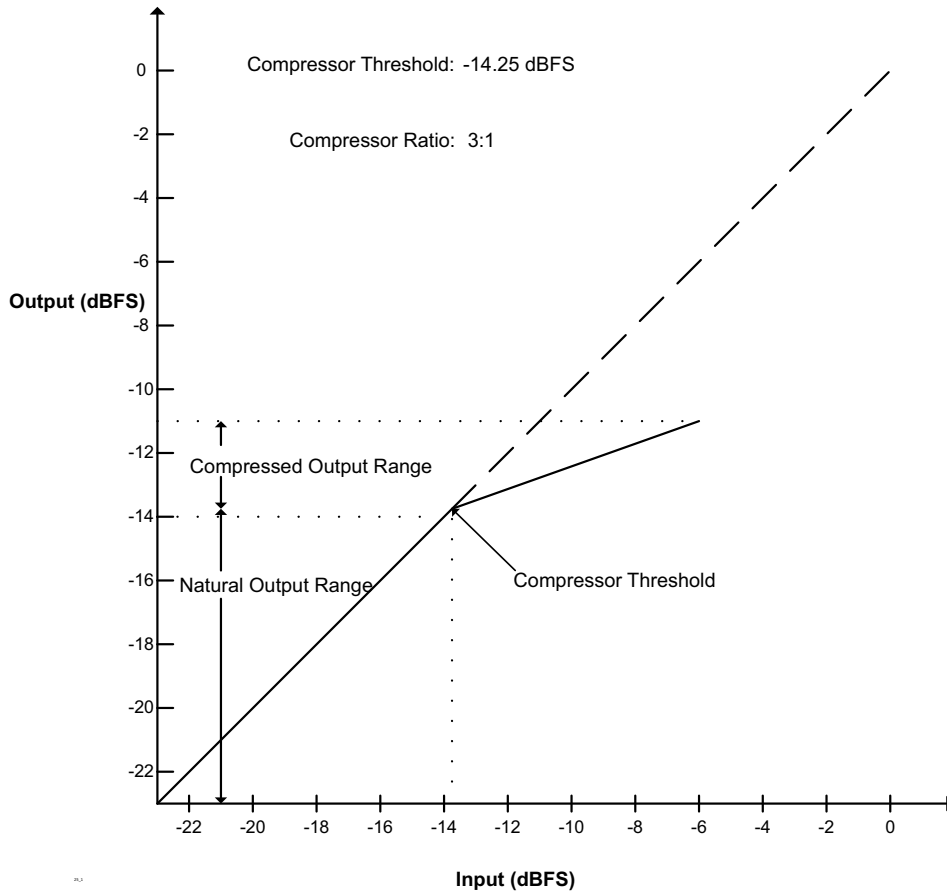

Figure 7. Gain Compressor, Output vs Input

#### 3.5.1. Overview

The TSCS42XX output processing includes a multi-band compressor that improves sound from small loudspeakers typically used in portable devices. Three independent compressor blocks are each preceded by a Bi-quad processing block that filters the incoming audio so that each compressor operates on a select range of audio frequencies. The advantage of multiband compression over full-bandwidth (full-band, or single-band) compression is that audible gain “pumping” can be reduced. When using single band compressors high energy audio content in a narrow range of frequencies can cause the volume of the entire audio frequency band to be affected thus causing the audio signal level to audibly “pump”. This pumping of the audio signal level can be distracting. A multi-band compressor can effectively elim-



inate or reduce the pumping to insignificant levels. An example of a crossover is at the bottom of Figure 8

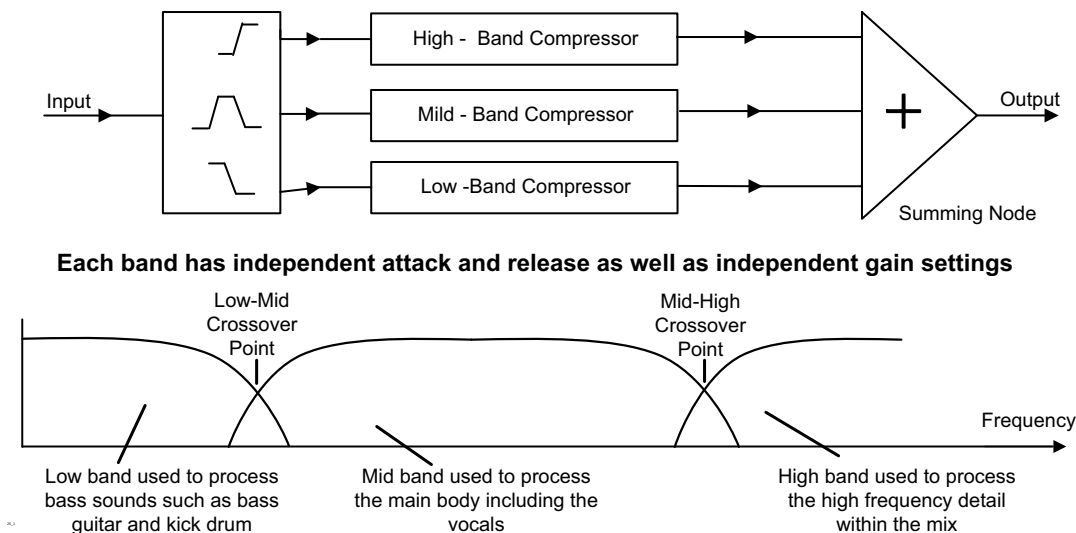

**Figure 8. block diagram Multiband compressor**

Each band in the Multi-band Compressor is comprised of a single stage 6-tap IIR (Bi-quad) filter followed by a compressor block. The Bi-quad filter coefficients are written using the Parametric Equalizer Registers. The purpose of the Bi-quad block is to provide a filter function for each Compressor band. The filter configuration can be lowpass, bandpass or highpass.

A basic block diagram of the compressor is shown below:

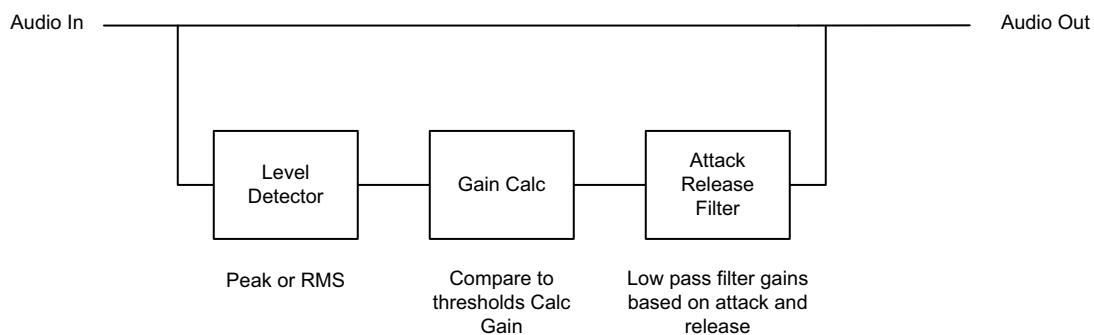

**Figure 9. Compressor block diagram**

As this diagram shows, there are 3 primary components of the compressor.

1. **Level Detector:** The level detector, detects the level of the incoming signal. Since the comp/limiter is designed to work on blocks of signals, the level detector will either find the peak value of the block of samples to be processed or the rms level of the samples within a block.
2. **Gain Calculation:** The gain calculation block is responsible for taking the output of the level detector and calculating a target gain based on that level and the compressor and expander Compression region gain calculation: In the compression region, the gain calculation is:

$$\text{Atten}(\text{in db}) = (1-1/\text{ratio})(\text{threshold}(\text{in db}) - \text{level}(\text{in db}));$$

- For example,
  - Ratio = 4:1 compression
  - Threshold = -16db
  - Level = -4 db

The required attenuation is: 9db or a gain coefficient of 0.1259.

Translating this calculation from log space to linear yields the formula:

$$\text{Gain} = (\text{level}/\text{threshold})^{1/\text{ratio}} * (\text{threshold}/\text{level})$$

- State Transitions: In addition to calculating the new gain for the compressor, the gain calculation block will also select the filter coefficient for the attack/release filter. The rules for selecting the coefficient are as follows:

In the compression region:

- If the gain calculated is less than the last gain calculated (more compression is being applied), then the filter coefficient is the compressor attack.
- If the gain calculated is more than the last gain calculated (less compression), the filter coefficient is the compressor release.

In the linear region:

- Modify gain until a gain of 1.0 is obtained, using the compressor release.

3. **Attack/Release filter:** In order to prevent objectionable artifacts, the gain is smoothly ramped from the current value to the new value calculated by the gain calculation block. This is achieved using a simple tracking lowpass filter to smooth out the abrupt transitions.

### 3.5.2. Multi band Compressor Registers

Register Address	Bit	Label	Type	Default	Description
Reg 199 (C7h) DACMBCEN	7:3	RSVD	R	0h	Reserved
	2	MBCEN3	RW	0	1 = enable compressor band 3
	1	MBCEN2	RW	0	1 = enable compressor band 2
	0	MBCEN1	RW	0	1 = enable compressor band 1

Table 20. DACMBCEN Register

# TSCS25xx

## Portable Consumer CODECs

Register Address	Bit	Label	Type	Default	Description
Reg 200 (C8h) DACMBCCTL	7:6	RSVD	R	0h	Reserved
	5	LVLMODE3	RW	0	Compressor Level Detection Mode Band 3 0 = Average 1 = Peak
	4	WINSEL3	RW	0	Window width selection for level detection Band 3 0 = equivalent of 512 samples of selected Base Rate (~10-16ms) 1 = equivalent of 64 samples of selected Base Rate (~1.3-2ms)
	3	LVLMODE2	RW	0	Compressor Level Detection Mode Band 2 0 = Average 1 = Peak
	2	WINSEL2	RW	0	Window width selection for level detection Band 2 0 = equivalent of 512 samples of selected Base Rate (~10-16ms) 1 = equivalent of 64 samples of selected Base Rate (~1.3-2ms)
	1	LVLMODE1	RW	0	Compressor Level Detection Mode Band 1 0 = Average 1 = Peak
	0	WINSEL1	RW	0	Window width selection for level detection Band 1 0 = equivalent of 512 samples of selected Base Rate (~10-16ms) 1 = equivalent of 64 samples of selected Base Rate (~1.3-2ms)

**Table 21. DACMBCCTL Register**

Register Address	Bit	Label	Type	Default	Description
Reg 201(C9h) DACMBCMUG1	7:5	RSVD	R	0h	Reserved
	5	PHASE	RW	0h	0 = not inverted 1 = Inverted
	4:0	MUGAIN[4:0]	RW	0h	0dB...46.5dB in 1.5dB steps

**Table 22. DACMBCMUG1 Register**

Register Address	Bit	Label	Type	Default	Description
Reg 202(CAh) DACMBCTHR1	7:0	THRESH[7:0]	RW	00h	FFh...00h = 0dB...95.625dB in 0.375dB steps.

**Table 23. DACMBCTHR1 Register**

Register Address	Bit	Label	Type	Default	Description
Reg 203(CBh) DACMBCRAT1	7:5	RSVD	R	000	Reserved
	4:0	RATIO[4:0]	RW	00h	Compressor Ratio 00h = Reserved 01h = 1.5:1 02h...14h = 2:1...20:1 15h...1Fh = Reserved

Table 24. DACMBCRAT1 Register

Register Address	Bit	Label	Type	Default	Description
Reg 204(CCh) DACMBCATK1L	7:0	TCATKL	RW	0h	Compressor Attack Time Constant, Low Byte

Table 25. DACMBCATK1L Register

Register Address	Bit	Label	Type	Default	Description
Reg 205(CDh) DACMBCATK1H	7:0	TCATKH[7:0]	RW	00h	High byte of the time constant used to ramp to a new gain value during a compressor attack phase. 0000h = 0 (instantaneous) 0001h = $0.96875 + 1/(2^{21})$ 0002h = $0.96875 + 2/(2^{21})$ ... (step = $1/(2^{21})$ ) FFFEh = $[(2^{21})-2]/(2^{21})$ FFFFh = $[(2^{21})-1]/(2^{21})$

Table 26. DACMBCATK1H Register

Register Address	Bit	Label	Type	Default	Description
Reg 206(CEh) DACMBCREL1L	7:0	TCRELL[7:0]	RW	00h	Low byte of the time constant used to ramp to a new gain value during a compressor release phase. 0000h = 0 (instantaneous) 0001h = $0.96875 + 1/(2^{21})$ 0002h = $0.96875 + 2/(2^{21})$ ... (step = $1/(2^{21})$ ) FFFEh = $[(2^{21})-2]/(2^{21})$ FFFFh = $[(2^{21})-1]/(2^{21})$

Table 27. DACMBCREL1L Register

Register Address	Bit	Label	Type	Default	Description
Reg 207(CFh) DACMBCREL1H	7:0	TCRELH[15:8]	RW	00h	High byte of the time constant used to ramp to a new gain value during a compressor release phase. The time constant is [high byte, low byte] 0000h = 0 (instantaneous) 0001h = $0.96875 + 1/(2^{21})$ 0002h = $0.96875 + 2/(2^{21})$ ... (step = $1/(2^{21})$ ) FFFEh = $[(2^{21})-2]/(2^{21})$ FFFFh = $[(2^{21})-1]/(2^{21})$

Table 28. DACMBCREL1H Register

Register Address	Bit	Label	Type	Default	Description
Reg 208(D0h) DACMBCMUG2	7:6	RSVD	R	0h	Reserved
	5	PHASE	RW	0h	0 = not inverted 1 = Inverted
	4:0	MUGAIN[4:0]	RW	0h	0dB...46.5dB in 1.5dB steps

Table 29. DACMBCMUG2 Register

Register Address	Bit	Label	Type	Default	Description
Reg 209(D1h) DACMBCTHR2	7:0	THRESH[7:0]	RW	00h	FFh...00h = 0dB...95.625dB in 0.375dB steps.

Table 30. DACMBCTHR2 Register

Register Address	Bit	Label	Type	Default	Description
Reg 210(D2h) DACMBCRAT2	7:5	RSVD	R	000	Reserved
	4:0	RATIO[4:0]	RW	00h	Compressor Ratio 00h = Reserved 01h = 1.5:1 02h...14h = 2:1...20:1 15h...1Fh = Reserved

Table 31. DACMBCRAT2 Register

Register Address	Bit	Label	Type	Default	Description
Reg 211(D3h) DACMBCATK2L	7:0	TCATKL[7:0]	RW	00h	Low byte of the time constant used to ramp to a new gain value during a compressor attack phase. 0000h = 0 (instantaneous) 0001h = $0.96875 + 1/(2^{21})$ 0002h = $0.96875 + 2/(2^{21})$ ... (step = $1/(2^{21})$ ) FFFEh = $[(2^{21})-2]/(2^{21})$ FFFFh = $[(2^{21})-1]/(2^{21})$

Table 32. DACMBCATK2L Register

Register Address	Bit	Label	Type	Default	Description
Reg 212(D4h) DACMBCATK2H	7:0	TCATKH[7:0]	RW	00h	High byte of the time constant used to ramp to a new gain value during a compressor attack phase. 0000h = 0 (instantaneous) 0001h = $0.96875 + 1/(2^{21})$ 0002h = $0.96875 + 2/(2^{21})$ ... (step = $1/(2^{21})$ ) FFFEh = $[(2^{21})-2]/(2^{21})$ FFFFh = $[(2^{21})-1]/(2^{21})$

Table 33. DACMBCATK2H Register

Register Address	Bit	Label	Type	Default	Description
Reg 213(D5h) DACMBCREL2L	7:0	TCRELL[7:0]	RW	00h	Low byte of the time constant used to ramp to a new gain value during a compressor release phase. 0000h = 0 (instantaneous) 0001h = $0.96875 + 1/(2^{21})$ 0002h = $0.96875 + 2/(2^{21})$ ... (step = $1/(2^{21})$ ) FFFEh = $[(2^{21})-2]/(2^{21})$ FFFFh = $[(2^{21})-1]/(2^{21})$

Table 34. DACMBCREL2L Register

Register Address	Bit	Label	Type	Default	Description
Reg 214(D6h) DACMBCREL2H	7:0	TCREL[15:8]	RW	00h	High byte of the time constant used to ramp to a new gain value during a compressor release phase. The time constant is [high byte, low byte] 0000h = 0 (instantaneous) 0001h = $0.96875 + 1/(2^{21})$ 0002h = $0.96875 + 2/(2^{21})$ ... (step = $1/(2^{21})$ ) FFFEh = $[(2^{21})-2]/(2^{21})$ FFFFh = $[(2^{21})-1]/(2^{21})$

Table 35. DACMBCREL2H Register

# TSCS25xx

## Portable Consumer CODECs

Register Address	Bit	Label	Type	Default	Description
Reg 215(D7h) DACMBCMUG3	7:5	RSVD	R	0h	Reserved
	5	PHASE	RW	0h	0 = not inverted 1 = Inverted
	4:0	MUGAIN[4:0]	RW	0h	0dB...46.5dB in 1.5dB steps

**Table 36. DACMBCMUG3 Register**

Register Address	Bit	Label	Type	Default	Description
Reg 216(D8h) DACMBCTHR3	7:0	THRESH[7:0]	RW	00h	FFh...00h = 0dB...95.625dB in 0.375dB steps.

**Table 37. DACMBCTHR3 Register**

Register Address	Bit	Label	Type	Default	Description
Reg 217(D9h) DACMBCRAT3	7:5	RSVD	R	000	Reserved
	4:0	RATIO[4:0]	RW	00h	Compressor Ratio 00h = Reserved 01h = 1.5:1 02h...14h = 2:1...20:1 15h...1Fh = Reserved

**Table 38. DACMBCRAT3 Register**

Register Address	Bit	Label	Type	Default	Description
Reg 218(DAh) DACMBCATK3L	7:0	TCATKL[7:0]	RW	00h	Low byte of the time constant used to ramp to a new gain value during a compressor attack phase. 0000h = 0 (instantaneous) 0001h = $0.96875 + 1/(2^{21})$ 0002h = $0.96875 + 2/(2^{21})$ ... (step = $1/(2^{21})$ ) FFFEh = $[(2^{21})-2]/(2^{21})$ FFFFh = $[(2^{21})-1]/(2^{21})$

**Table 39. DACMBCATK3L Register**

Register Address	Bit	Label	Type	Default	Description
Reg 219(DBh) DACMBCATK3H	7:0	TCATKHH[7:0]	RW	00h	High byte of the time constant used to ramp to a new gain value during a compressor attack phase. 0000h = 0 (instantaneous) 0001h = $0.96875 + 1/(2^{21})$ 0002h = $0.96875 + 2/(2^{21})$ ... (step = $1/(2^{21})$ ) FFFEh = $[(2^{21})-2]/(2^{21})$ FFFFh = $[(2^{21})-1]/(2^{21})$

Table 40. DACMBCATK3H Register

Register Address	Bit	Label	Type	Default	Description
Reg 220(DCh) DACMBCREL3L	7:0	TCRELL[7:0]	RW	00h	Low byte of the time constant used to ramp to a new gain value during a compressor release phase. 0000h = 0 (instantaneous) 0001h = $0.96875 + 1/(2^{21})$ 0002h = $0.96875 + 2/(2^{21})$ ... (step = $1/(2^{21})$ ) FFFEh = $[(2^{21})-2]/(2^{21})$ FFFFh = $[(2^{21})-1]/(2^{21})$

Table 41. DACMBCREL3L Register

Register Address	Bit	Label	Type	Default	Description
Reg 221(DDh) DACMBCREL3H	7:0	TCRELH[15:8]	RW	00h	High byte of the time constant used to ramp to a new gain value during a compressor release phase. The time constant is [high byte, low byte] 0000h = 0 (instantaneous) 0001h = $0.96875 + 1/(2^{21})$ 0002h = $0.96875 + 2/(2^{21})$ ... (step = $1/(2^{21})$ ) FFFEh = $[(2^{21})-2]/(2^{21})$ FFFFh = $[(2^{21})-1]/(2^{21})$

Table 42. DACMBCREL3H Register



### 3.6. Limiter/Compressor/Expander

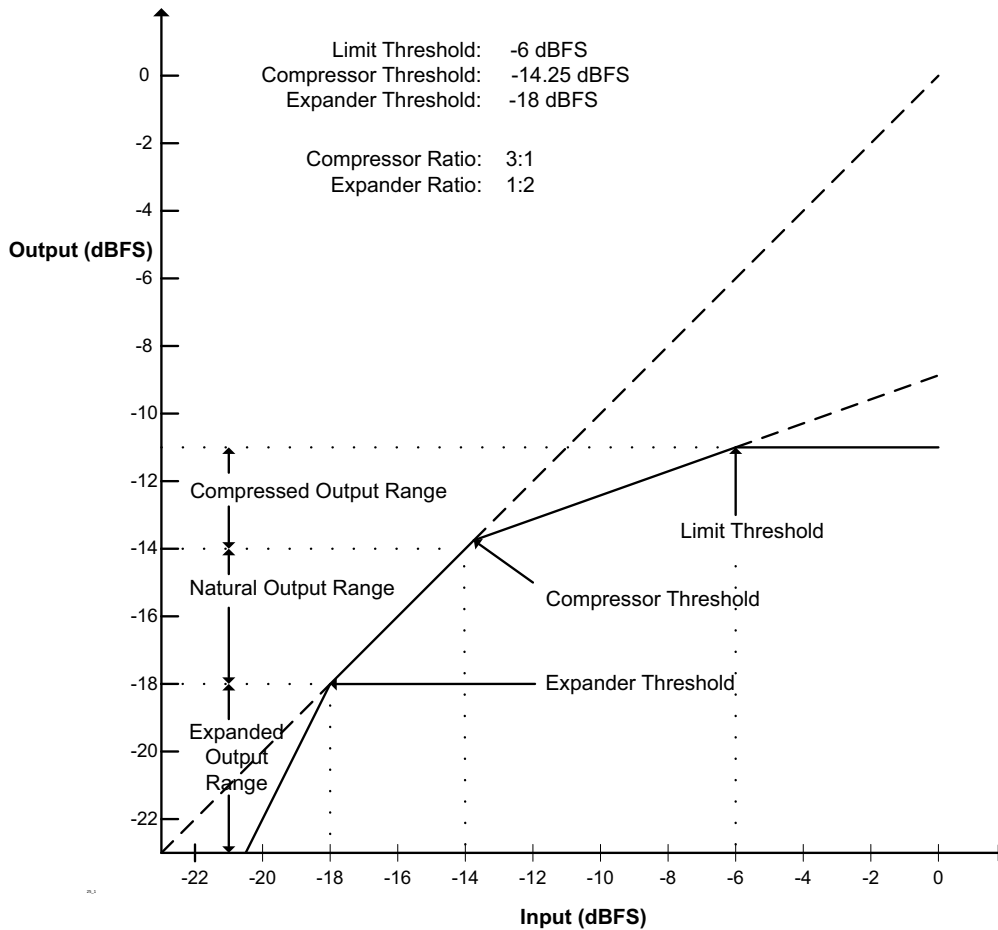

Figure 10. Gain Compressor, Output vs Input

#### 3.6.1. Overview

The Limiter function will limit the output of the DSP module to the DAC modules. If the signal is greater than 0dB it will saturate at 0dB as the final processing step within the DSP module.

Sometimes, the system implementor may wish to provide hearing protection by intentionally limiting the output level before full scale is reached. A limit threshold, independent of the compressor threshold is provided for this purpose. It is expected that the limit threshold is set to a higher level than the compressor threshold.

The traditional compressor algorithm provides two functions simultaneously (depending on signal level). For higher level signals, it can provide a compression function to reduce the signal level. For lower level signals, it can provide an expansion function for either increasing dynamic range or noise gating.

The compressor monitors the signal level and, if the signal is higher than a threshold, will reduce the gain by a programmed ratio to restrict the dynamic range. Limiting is an extreme example of the compressor where, as the input signal level is increased, the gain is decreased to maintain a specific output level.

In addition to limiting the bandwidth of the compressed audio, it is common for compressed audio to also compress the dynamic range of the audio. The expansion function in TSCS25xx can help restore the original dynamics to the audio.

The expander is a close relative of the compressor. Rather than using signal dependent gain to restrict the dynamic range, the expander uses signal dependent gain to expand the dynamic range. Thus if a signal level is below a particular threshold, the expander will reduce the gain even further to extend the dynamic range of the material.

### 3.6.2. Configuration

This compressor limiter provides the following configurable parameters.

- Compressor/limiter
  - Threshold – The threshold above which the compressor will reduce the dynamic range of the audio in the compression region.
  - Ratio – The ratio between the input dynamic range and the output dynamic range. For example, a ratio of 3 will reduce an input dynamic range of 9db to 3db.
  - Attack Time – The amount of time that changes in gain are smoothed over during the attack phase of the compressor.
  - Release Time – The amount of time that changes in gain are smoothed over during the release phase of the compressor.
  - Makeup gain – Used to increase the overall level of the compressed audio.
- Expander
  - Threshold – The threshold below which the expander will increase the dynamic range of the audio.
  - Ratio – The ratio between the input dynamic range and the output dynamic range of the audio in the expansion range. For example a ratio of 3 will take an input dynamic range of 9db and expand it to 27db.
  - Attack Time – The amount of time that changes in gain are smoothed over during the attack phase of the expander
  - Release Time
    - The amount of time that changes in gain are smoothed over during the release phase of the expander.
- Two level detection algorithms
  - RMS – Use an RMS measurement for the level.
  - Peak – Use a peak measurement for the level.

### 3.6.3. Controlling parameters

In order to control this processing, there are a number of configurable parameters. The parameters and their ranges are:

- Compressor/limiter
  - Threshold – -40db to 0db relative to full scale.
  - Ratio – 1 to 20
  - Attack Time – typically 0 to 500ms
  - Release Time – typically 25ms to 2 seconds
  - Makeup gain – 0 to 40db
- Expander
  - Threshold – -30 to -60 dB
  - Ratio – 1 to 6
  - Attack Time – same as above
  - Release Time – same as above.
- Two level detection algorithms
  - RMS
  - Peak

### 3.6.4. Limiter/Compressor/Expander Registers

#### 3.6.4.1. General compressor/limiter/expander control Register

Register Address	Bit	Label	Type	Default	Description
R37 (25h) CLECTL	7:5	RSVD	R	0h	Reserved
	4	Lvl_Mode	RW	0	CLE Level Detection Mode 0 = Average 1 = Peak
	3	WindowSel	RW	0	Window width selection for level detection: 0 = equivalent of 512 samples of selected Base Rate (~10-16ms) 1 = equivalent of 64 samples of selected Base Rate (~1.3-2ms)
	2	Exp_en	RW	0	1 = enable expander
	1	Limit_en	RW	0	1 = enable limiter
	0	Comp_en	RW	0	1 = enable compressor

**Table 43. CLECTL Register**

3.6.4.2. Compressor/Limiter/Expander make-up gain Register

Register Address	Bit	Label	Type	Default	Description
R38 (26h) MUGAIN	7:5	RSVD	R	0h	Reserved
	4:0	CLEMUG[4:0]	RW	0h	0dB...46.5dB in 1.5dB steps

Table 44. MUGAIN Register

3.6.4.3. Compressor Threshold Register

Register Address	Bit	Label	Type	Default	Description
R39 (27h) COMPTH	7:0	COMPTH[7:0]	RW	00h	FFh...00h = 0dB...95.625dB in 0.375dB steps.

Table 45. COMPTH Register

3.6.4.4. Compressor ration register

Register Address	Bit	Label	Type	Default	Description
R40 (28h) CMPRAT	7:5	RSVD	R	000	Reserved
	4:0	CMPRAT[4:0]	RW	00h	Compressor Ratio 00h = Reserved 01h = 1.5:1 02h...14h = 2:1...20:1 15h...1Fh = Reserved

Table 46. CMPRAT Register

3.6.4.5. Compressor Attack Time Constant Register (Low)

Register Address	Bit	Label	Type	Default	Description
R41 (29h) CATKTCL	7:0	CATKTC[7:0]	RW	00h	Low byte of the time constant used to ramp to a new gain value during a compressor attack phase.

Table 47. CATKTCL Register

## 3.6.4.6. Compressor Attack Time Constant Register (High)

Register Address	Bit	Label	Type	Default	Description
R42 (2Ah) CATKTCH	7:0	CATKTC[15:8]	RW	00h	High byte of the time constant used to ramp to a new gain value during a compressor attack phase. The time constant is [high byte, low byte] 0000h = 0 (instantaneous) 0001h = $0.96875 + 1/(2^{21})$ 0002h = $0.96875 + 2/(2^{21})$ ... (step = $1/(2^{21})$ ) FFFEh = $[(2^{21})-2]/(2^{21})$ FFFFh = $[(2^{21})-1]/(2^{21})$

Table 48. CATKTCH Register

## 3.6.4.7. Compressor Release Time Constant Register (Low)

Register Address	Bit	Label	Type	Default	Description
R43 (2Bh) CRELTCL	7:0	CRELTC[7:0]	RW	00h	Low byte of the time constant used to ramp to a new gain value during a compressor release phase.

Table 49. CRELTCL Register

## 3.6.4.8. Compressor Release Time Constant Register (High)

Register Address	Bit	Label	Type	Default	Description
R44 (2Ch) CRELTCH	7:0	CRELTC[15:8]	RW	00h	High byte of the time constant used to ramp to a new gain value during a compressor release phase. The time constant is [high byte, low byte] 0000h = 0 (instantaneous) 0001h = $0.96875 + 1/(2^{21})$ 0002h = $0.96875 + 2/(2^{21})$ ... (step = $1/(2^{21})$ ) FFFEh = $[(2^{21})-2]/(2^{21})$ FFFFh = $[(2^{21})-1]/(2^{21})$

Table 50. CRELTCH Register

## 3.6.4.9. Limiter Threshold Register

Register Address	Bit	Label	Type	Default	Description
R45 (2Dh) LIMTH	7:0	LIMTH[7:0]	RW	00h	FFh...00h = 0dB...95.625dB in 0.375dB steps.

Table 51. LIMTH Register

## 3.6.4.10. Limiter Target Register

Register Address	Bit	Label	Type	Default	Description
R46 (2Eh) LIMTGT	7:0	LIMTGT[7:0]	RW	00h	FFh...00h = 0dB...95.625dB in 0.375dB steps.

Table 52. LIMTGT Register

## 3.6.4.11. Limiter Attack Time Constant Register (Low)

Register Address	Bit	Label	Type	Default	Description
R47 (2Fh) LATKTCL	7:0	LATKTTC[7:0]	RW	00h	Low byte of the time constant used to ramp to a new gain value during a limiter attack phase.

Table 53. LATKTCL Register

## 3.6.4.12. Limiter Attack Time Constant Register (High)

Register Address	Bit	Label	Type	Default	Description
R48 (30h) LATKTCH	7:0	LATKTTC[15:8]	RW	00h	High byte of the time constant used to ramp to a new gain value during a limiter attack phase. The time constant is [high byte, low byte] 0000h = 0 (instantaneous) 0001h = $0.96875 + 1/(2^{21})$ 0002h = $0.96875 + 2/(2^{21})$ ... (step = $1/(2^{21})$ ) FFFEh = $[(2^{21})-2]/(2^{21})$ FFFFh = $[(2^{21})-1]/(2^{21})$

Table 54. LATKTCH Register

## 3.6.4.13. Limiter Release Time Constant Register (Low)

Register Address	Bit	Label	Type	Default	Description
R49 (31h) LRELTC	7:0	LRELTC[7:0]	RW	00h	Low byte of the time constant used to ramp to a new gain value during a limiter release phase.

Table 55. LRELTC Register

3.6.4.14. Limiter Release Time Constant Register (High)

Register Address	Bit	Label	Type	Default	Description
R50 (32h) LRELTCH	7:0	LRELTCH[15:8]	RW	00h	High byte of the time constant used to ramp to a new gain value during a limiter release phase. The time constant is [high byte, low byte] 0000h = 0 (instantaneous) 0001h = $0.96875 + 1/(2^{21})$ 0002h = $0.96875 + 2/(2^{21})$ ... (step = $1/(2^{21})$ ) FFFEh = $[(2^{21})-2]/(2^{21})$ FFFFh = $[(2^{21})-1]/(2^{21})$

Table 56. LRELTCH Register

3.6.4.15. Expander Threshold Register

Register Address	Bit	Label	Type	Default	Description
R51 (33h) EXPTH	7:0	EXPTH[7:0]	RW	00h	Expander threshold: 0...95.625dB in 0.375dB steps

Table 57. EXPTH Register

3.6.4.16. Expander Ratio Register

Register Address	Bit	Label	Type	Default	Description
R52 (34h) EXPRAT	7:3	RSVD	R	00h	Reserved
	2:0	EXPRAT[2:0]	RW	000	Expander Ratio 0h...1h = Reserved 2h...7h = 1:2...1:7

Table 58. EXPRAT Register

3.6.4.17. Expander Attack Time Constant Register (Low)

Register Address	Bit	Label	Type	Default	Description
R53 (35h) XATKTCL	7:0	XATKTCL[7:0]	RW	00h	Low byte of the time constant used to ramp to a new gain value during an expander attack phase.

Table 59. XATKTCL Register

3.6.4.18. *Expander Attack Time Constant Register (High)*

Register Address	Bit	Label	Type	Default	Description
R54 (36h) XATKTCH	7:0	XATKTC[15:8]	RW	00h	High byte of the time constant used to ramp to a new gain value during a expander attack phase. The time constant is [high byte, low byte] 0000h = 0 (instantaneous) 0001h = $0.96875 + 1/(2^{21})$ 0002h = $0.96875 + 2/(2^{21})$ ... (step = $1/(2^{21})$ ) FFFEh = $[(2^{21})-2]/(2^{21})$ FFFFh = $[(2^{21})-1]/(2^{21})$

Table 60. XATKTCH Register

3.6.4.19. *Expander Release Time Constant Register (Low)*

Register Address	Bit	Label	Type	Default	Description
R55 (37h) XRELTCL	7:0	XRELTC[7:0]	RW	0	Low byte of the time constant used to ramp to a new gain value during a expander release phase.

Table 61. XRELTCL Register

3.6.4.20. *Expander Release Time Constant Register (High)*

Register Address	Bit	Label	Type	Default	Description
R56 (38h) XRELTCH	7:0	XRELTC[15:8]	RW	0	High byte of the time constant used to ramp to a new gain value during a expander release phase. The time constant is [high byte, low byte] 0000h = 0 (instantaneous) 0001h = $0.96875 + 1/(2^{21})$ 0002h = $0.96875 + 2/(2^{21})$ ... (step = $1/(2^{21})$ ) FFFEh = $[(2^{21})-2]/(2^{21})$ FFFFh = $[(2^{21})-1]/(2^{21})$

Table 62. XRELTCH Register

## 3.7. Output Effects

The TSCS42XX offers Bass enhancement, Treble enhancement, Stereo Depth enhancement. The output effects processing is outlined in the following sections.



### 3.7.1. FX Control Register

Register Address	Bit	Label	Type	Default	Description
R57 (39h) FXCTL	7:5	RSVD	R	000	Reserved
	4	3DEN	RW	0	3D Enhancement Enable 0 = Disabled 1 = Enabled
	3	TEEN	RW	0	Treble Enhancement Enable 0 = Disabled 1 = Enabled
	2	TNLFBYP	RW	0	Treble Non-linear Function Bypass: 0 = Enabled 1 = Bypassed
	1	BEEN	RW	0	Bass Enhancement Enable 0 = Disabled 1 = Enabled
	0	BNLFBYP	RW	0	Bass Non-linear Function Bypass: 0 = Enabled 1 = Bypassed

Table 63. FXCTL Register

### 3.7.2. Stereo Depth (3-D) Enhancement

The TSCS42XX has a digital depth enhancement option to artificially increase the separation between the left and right channels, by enabling the attenuation of the content common to both channels. The amount of attenuation is programmable within a range. The input is prescaled (fixed) before summation to prevent saturation.

The 3-D enhancement algorithm is a tried and true algorithm that uses two principles.

- 1 If the material common to the two channels is removed, then the output will sound more 3-D.
- 2 If the material for the opposite channel is presented to the current channel inverted, it will tend to cancel any material from the opposite channel on the current ear. For example, if the material from the right is presented to the left ear inverted, it will cancel some of the material from the right ear that is leaking into the right ear.

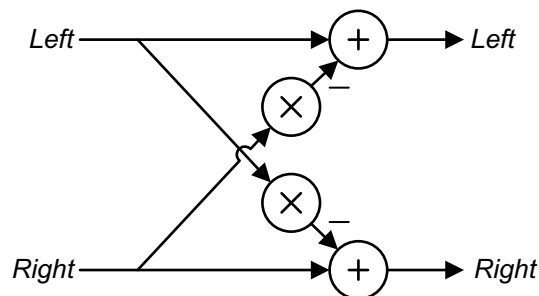

Figure 11. 3-D Channel Inversion

*Note: .3D\_Mix specifies the amount of the common signal that is added from the left and right channels. This number is a fractional amount between -1 and 1. For proper operation, this value is typically negative.*

### 3.7.3. Psychoacoustic Bass Enhancement

One of the primary audio quality issues with small speaker systems is their inability to reproduce significant amounts of energy in the bass region (below 200Hz). While there is no magic mechanism to make a speaker reproduce frequencies that it is not capable of, there are mechanisms for fooling the ear into thinking that the bass material is being heard.

The psychoacoustic bass processor relies on a psychoacoustic principle called "missing fundamental". If the human ear hears a proper series of harmonics for a particular bass note, the listener will hear the fundamental of that series, even if it is not present.

A processing algorithm using this principle allows for improving the apparent low frequency response of an audio system below what it is actually capable of. Below is a diagram of the implementation of this algorithm.

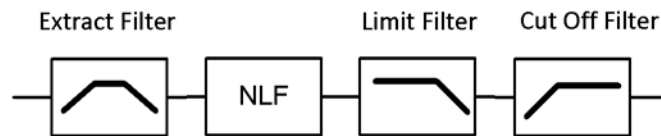

Figure 12. Bass Enhancement

### 3.7.4. Treble Enhancement

One of the mechanisms used to limit the bit rate for compressed audio is to first remove high frequency information before compression. When these files are decompressed, this can lead to dull sounding audio. The TSI treble enhancement replaces these lost high frequencies.

The enhanced treble function works much like the enhanced bass, however it's intended use is different. The Enhanced treble uses a non linear function to add treble harmonics to a signal that has limited high-frequency bandwidth (such as a low bit rate MP3). In this case, the algorithm makes use of the audio fact that presence of audio between 4-8K is a good predictor of audio between 10K-20K.

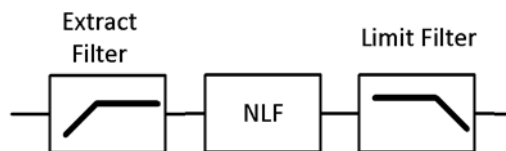

Figure 13. Treble Enhancement

The enhanced treble NLF has a different set of requirements than the psychoacoustic bass. In particular, the presence of odd high frequency harmonics is objectionable. Thus the most promising NLF for enhanced treble is a half wave rectifier.

## 3.8. Mute and De-Emphasis

The TSCS42XX has a Soft Mute function, which is used to gradually attenuate the digital signal volume to zero. The gain returns to its previous setting if the soft mute is removed. At startup, the codec is muted by default; to enable audio play, the mute bit must be cleared to 0.

After the equalization filters, de-emphasis may be performed on the audio data to compensate for pre-emphasis that may be included in the audio stream. De-emphasis filtering is only available for 48kHz, 44.1kHz, and 32kHz sample rates.

### 3.9. Mono Operation and Phase Inversion

Normal stereo operation converts left and right channel digital audio data to analog in separate DACs. However, it is also possible to have the same signal (left or right) appear on both analog output channels by disabling one channel; alternately, there is a mono-mix mode that mixes the two channels digitally before converting to analog using only one DAC. In this mode, the other DAC is switched off, and the resulting mixed stream signal can appear on both analog output channels.

The DAC output defaults to non-inverted. Setting DACPOLL and DACPOLR bits will invert the DAC output phase on the left and right channels.

#### 3.9.1. DAC Control Register

Register Address	Bit	Label	Type	Default	Description
R24 (18h) CNVRTR1	7	DACPOLR	RW	0	Invert DAC Right signal
	6	DACPOLL	RW	0	Invert DAC Left signal
	5:4	DMONOMIX [1:0]	RW	00	DAC mono mix 00: stereo 01: mono ((L/2)+(R/2)) into DACL, '0' into DACR 10: mono ((L/2)+(R/2)) into DACR, '0' into DACL 11: mono ((L/2)+(R/2)) into DACL and DACR
	3	DACMU	RW	1	Digital Soft Mute 1 = mute 0 = no mute (signal active)
	2	DEEMP	RW	0	De-emphasis Enable 1 = Enabled 0 = Disable
	1:0	DACDITH	RW	00	DAC Dither Mode: 0 = Dynamic, half amplitude 1 = Dynamic, full amplitude 2 = DAC dither disabled 3 = Static

Table 64. CNVRTR1 Register

### 3.10. Analog Outputs

#### 3.10.1. Headphone Output

The HPOut pins can drive a 16Ohm or 32Ohm headphone or alternately drive a line output. The signal volume of the headphone amplifier can be independently adjusted under software control by writing to HPVOL\_L and HPVOL\_R. Setting the volume to 0000000 will mute the output driver; the output remains at ground, so that no click noise is produced when muting or un-muting.

Gains above 0dB run the risk of clipping large signals.

To minimize artifacts such as clicks and zipper noise, the headphone outputs feature a volume fade function that smoothly changes volume from the current value to the target value.

# TSCS25xx

## Portable Consumer CODECs

### Headphone Volume Control Registers

Register Address	Bit	Label	Type	Default	Description
R0 (00h) HPVOLL	7	RSVD	R	0	Reserved
	6:0	HPVOL_L [6:0]	RW	1110111 (0dB)	Left Headphone Volume 1111111 = +6dB 1111110 = +5.25dB ... 1110111 = 0dB ... 0000001 = -88.5dB 0000000 = Analog mute Note: If HPVOLU is set, this setting will take effect after the next write to the Right Input Volume register.
R1 (01h) HPVOLR	7	RSVD	R	0	Reserved
	6:0	HPVOL_R [6:0]	RW	1110111	Right Headphone Volume 1111111 = +6dB 1111110 = +5.25dB ... 1110111 = 0dB ... 0000001 = -88.5dB 0000000 = Analog mute

Table 65. HPVOL L/R Registers

## 4. INPUT AUDIO PROCESSING

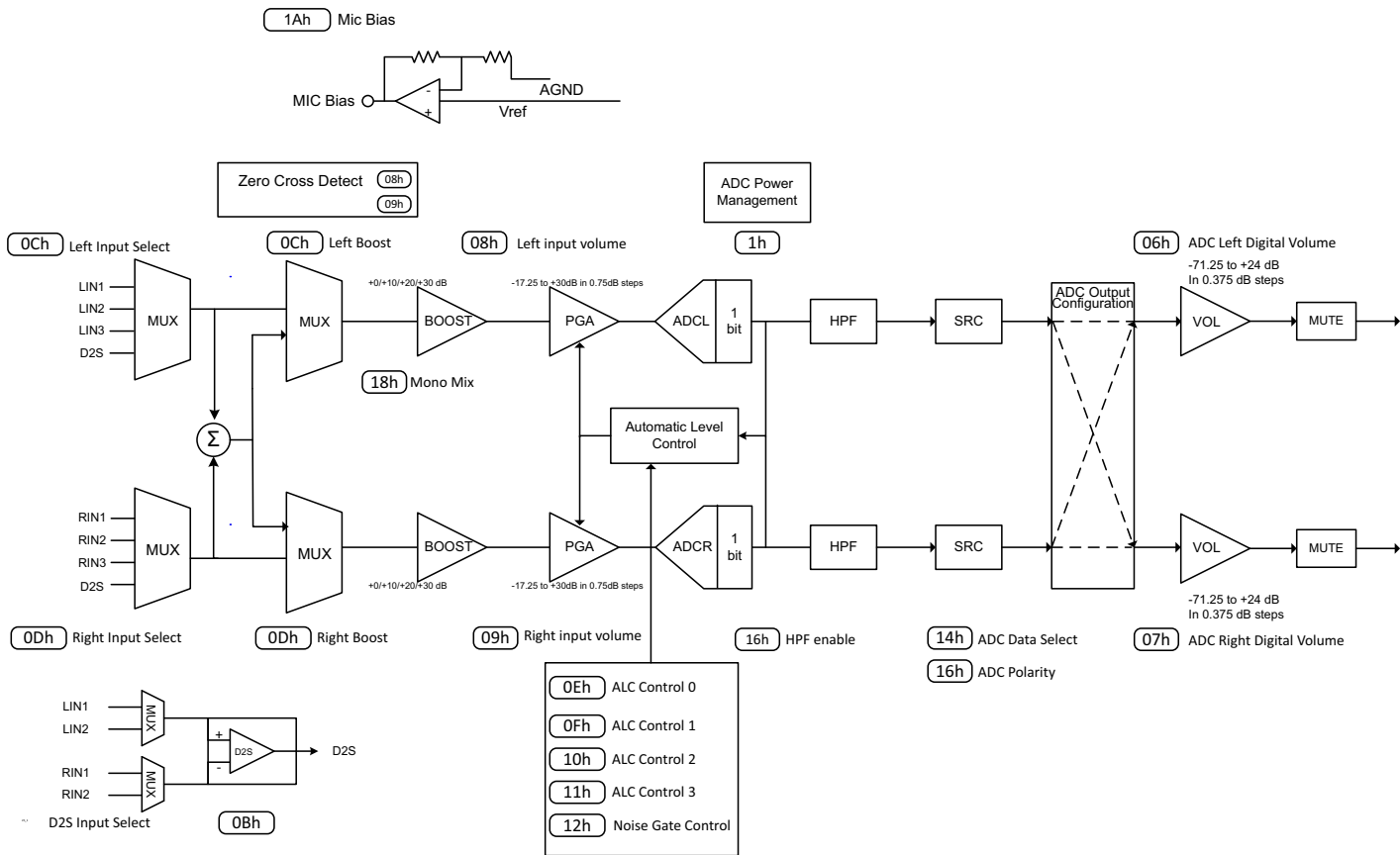

Figure 14. Input Audio Processing

### 4.1. Analog Inputs

The TSCS42XX provides multiple high impedance, low capacitance AC-coupled analog inputs with an input signal path to the stereo ADCs. Prior to the ADC, there is a multiplexor that allows the system to select which input is in use. Following the mux, there is a programmable gain amplifier and also an optional microphone gain boost. The gain of the PGA can be controlled either by the system, or by the on-chip level control function. The stereo record path can also operate with the two channels mixed to mono either in the analog or digital domains.

Signal inputs are biased internally to AVSS but AC coupling capacitors are required when connecting microphones (due to the 2.5V microphone bias) or when offsets would cause unacceptable "zipper noise" or pops when changing PGA or boost gain settings. To avoid audio artifacts, the line inputs are kept biased to analog ground when they are muted or the device is placed into standby mode.

**4.1.1. Input Software Control Register**

Register Address	Bit	Label	Type	Default	Description
R12 (0Ch) INSELL	7:6	INSEL_L	RW	00	Left Channel Input Select 00 = LINPUT1 01 = LINPUT2 10 = Reserved 11 = D2S
	5:4	MICBST_L	RW	00	Left Channel Microphone Gain Boost 00 = Boost off (bypassed) 01 = 10dB boost 10 = 20dB boost 11 = 30dB boost
	3:0	RSVD	R	0000	Reserved
R13 (0Dh) INSELR	7:6	INSEL_R	RW	00	Right Channel Input Select 00 = RINPUT1 01 = RINPUT2 10 = Reserved 11 = D2S
	5:4	MICBST_R	RW	00	Right Channel Microphone Gain Boost 00 = Boost off (bypassed) 01 = 10dB boost 10 = 20dB boost 11 = 30dB boost
	3:0	RSVD	R	0000	Reserved

Table 66. INSELL and INSLR Register

**4.2. Mono Mixing and Output Configuration**

The stereo ADC can operate as a stereo or mono device, or the two channels can be mixed to mono. Mixing can occur either in the input path (analog, before ADC) or after the ADC. MONOMIX determines whether to mix to mono, and where.

For analog mono mix, either the left or right channel ADC can be used for the audio stream. The other ADC may be powered off to conserve power. A differential input amplifier may be selected as a mono source to either ADC input. This D2S amplifier can select either Input 1 or Input 2 using the DS bit.

The system also has the flexibility to select the data output. ADCDSEL configures the interface, assigning the source of the left and right ADC independently.

**4.2.1. ADC D2S Input Mode Register**

Register Address	Bit	Label	Type	Default	Description
R11 (0Bh) INMODE	7:1	RSVD	R	0h	Reserved
	0	DS	RW	0	Differential Input Select 0: LIN1 - RIN1 1: LIN2 - RIN2

Table 67. INMODE Register

**4.2.2. ADC Mono, Filter, and Inversion**

Register Address	Bit	Label	Type	Default	Description
R22 (16h) CNVRTR0	7	ADCPOLR	RW	0	ADC Right Channel Polarity 0 = normal 1 = inverted
	6	ADCPOLL	RW	0	ADC Left Channel Polarity 0 = normal 1 = inverted
	5:4	AMONOMIX [1:0]	RW	00	ADC mono mix 00: Stereo 01: Analog Mono Mix (using left ADC) 10: Analog Mono Mix (using right ADC) 11: Digital Mono Mix (ADCL/2 + ADCR/2 on both Left and Right ADC outputs)
	3	ADCMU	RW	1	1 = Mute ADC
	2	HPOR	RW	0	High Pass Offset Result 0 = discard offset when HPF disabled 1 = store and use last calculated offset when HPF disabled
	1	ADCHPDR	RW	0	ADC High Pass Filter Disable (Right)
	0	ADCHPDL	RW	0	ADC High Pass Filter Disable (Left)

**Table 68. CNVRTR0 Register****4.2.3. ADC Data Output Configuration**

Register Address	Bit	Label	Type	Default	Description
R20 (14h) AIC2	7:6	DACDSEL[1:0]	RW	00	00: left DAC = left I2S data; right DAC = right I2S data 01: left DAC = left I2S data; right DAC = left I2S data 10: left DAC = right I2S data; right DAC = right I2S data 11: left DAC = right I2S data; right DAC = left I2S data
	5:4	ADCSEL[1:0]	RW	00	00: left I2S data = left ADC; right I2S data = right ADC 01: left I2S data = left ADC; right I2S data = left ADC 10: left I2S data = right ADC; right I2S data = right ADC 11: left I2S data = right ADC; right I2S data = left ADC
	3	TRI	RW	0	Interface Tri-state (See Section 5.4.2)
	2:0	BLRCM	RW	0	Bitclock and LRClock mode (See Section 5.4.2)

**Table 69. AIC2 Register****4.3. Microphone Bias**

The MICBIAS output is used to bias electric type microphones. It provides a low noise reference voltage used for an external resistor biasing network. The MICB control bit is used to enable the output.

The MICBIAS can source up to 3mA of current; therefore, the external resistors must be large enough to conform to this limit.

4.3.1. Microphone Bias Control Bit

Register Address	Bit	Label	Type	Default	Description
R26 (1Ah) PWRM1	1	MICB	RW	0	Microphone Bias Enable 0 = OFF (high impedance output) 1 = ON

Table 70. Mic Bias Enable

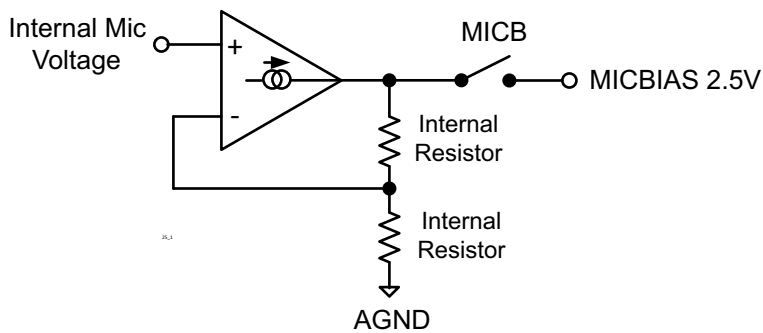

Figure 15. Mic Bias

4.4. Programmable Gain Control

The Programmable Gain Amplifier (PGA) enables the input signal level to be matched to the ADC input range. Amplifier gain is adjustable across the range +30dB to -17.25dB (using 0.75dB steps). The PGA can be controlled directly by the system software using the Input Volume Control registers (INVOLL and INVOLR), or alternately the Automatic Level Control (ALC) function can automatically control the gain. If the ALC function is used, writing to the Input Volume Control registers has no effect.

Left and right input gains are independently adjustable. By controlling the update bit INVOLU in R10 the left and right gain settings can be simultaneously updated. To eliminate zipper noise, LZCEN and RZCEN bits enable a zero-cross detector to insure changes only occur when the signal is at zero. A time-out for zero-cross is also provided, using TOEN in register R28 (1Dh).



**4.4.1. Input PGA Software Control Register**

Register Address	Bit	Label	Type	Default	Description
R8 (08h) INVOLL	7	INMUTEL	RW	0	Left Input Mute: 1 = Enable mute 0 = Disable mute Note: If INVOLU is set, this setting will take effect after the next write to the right Input Volume Register
	6	IZCL	RW	0	Left Channel Zero Cross Detector 1 = Change gain on zero cross only 0 = Change gain immediately Note: If INVOLU is set, this setting will take effect after the next write to the Right Input Volume register.
	5:0	INVOL_L [5:0]	RW	010111 (0dB)	Left Channel Input Volume Control 111111 = +30dB 111110 = +29.25dB ... 0.75dB steps down to 000000 = -17.25dB Note: If INVOLU is set, this setting will take effect after the next write to the Right Input Volume register.
R9 (09h) INVOLR	7	RSVD	R	0	Reserved
	6	IZCR	RW	0	Right Channel Zero Cross Detector 1 = Change gain on zero cross only 0 = Change gain immediately
	5:0	INVOL_R [5:0]	RW	010111 (0dB)	Right Channel Input Volume Control 111111 = +30dB 111110 = +29.25dB ... 0.75dB steps down to 000000 = -17.25dB
R28 (1Ch) CTL	0	TOEN	RW	0	Zero Cross Time-out Enable 0: Time-out Disabled 1: Time-out Enabled - volumes updated if no zero cross event has occurred before time-out

**Table 71. INVOLL/ INVOLR Register**

**4.5. ADC Digital Filter**

To provide the correct sampling frequency on the digital audio outputs, ADC filters perform true 24-bit signal processing and convert the raw multi-bit oversampled data from the ADC using the digital filter path illustrated below.

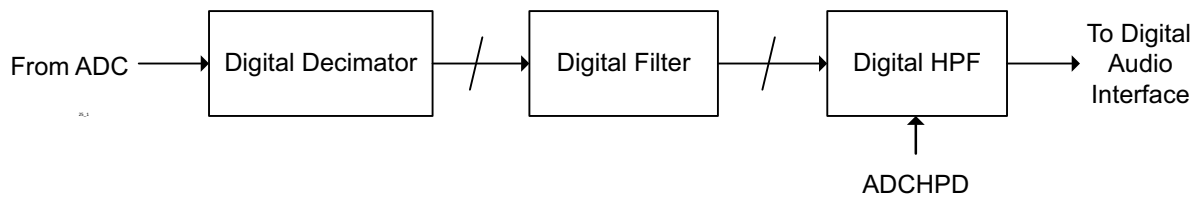

**Figure 16. ADC Filter Data Path**

## TSCS25xx

### Portable Consumer CODECs

The ADC digital filters contain a software-selectable digital high pass filter. When the high-pass filter is enabled, the dc offset is continuously calculated and subtracted from the input signal. The HPOR bit enables the last calculated DC offset value to be stored when the high-pass filter is disabled; this value will then continue to be subtracted from the input signal. To provide support for calibration, the stored and subtracted value will not change unless the high-pass filter is enabled even if the DC value is changed. The high pass filter may be enabled separately for each of the left and right channels.

The output data format can be programmed by the system. This allows stereo or mono recording streams at both inputs. Software can change the polarity of the output signal.

#### 4.5.1. ADC Signal Path Control Register

Register Address	Bit	Label	Type	Default	Description
R22 (16h) CNVRTR0	7	ADCPOLR	RW	0	0 = Right polarity not inverted 1 = Right polarity inverted
	6	ADCPOLL	RW	0	0 = Left polarity not inverted 1 = Left polarity inverted
	5:4	AMONOMIX [1:0]	RW	00	ADC mono mix 00: Stereo 01: Analog Mono Mix (using left ADC) 10: Analog Mono Mix (using right ADC) 11: Digital Mono Mix
	3	ADCMU	RW	1	1 = Mute ADC
	2	HPOR	RW	0	High Pass Offset Result 0 = discard offset when HPF disabled 1 = store and use last calculated offset when HPF disabled
	1	ADCHPDR	RW	0	ADC High Pass Filter Disable (Right)
	0	ADCHPDL	RW	0	ADC High Pass Filter Disable (Right)

Table 72. CNVRTR0 Register

#### 4.5.2. ADC High Pass Filter Enable Modes

ADCHPDR	ADCHPDL	High Pass Mode
0	0	High-pass filter enabled on left and right channels
0	1	High-pass filter disabled on left channel, enabled on right channel
1	0	High-pass filter enabled on left channel, disabled on right channel
1	1	High-pass filter disabled on left and right channels

Table 73. ADC HPF Enable

## 4.6. Digital ADC Volume Control

The ADC volume can be controlled digitally, across a gain and attenuation range of -71.25dB to +24dB (0.375dB steps). The level of attenuation is specified by an eight-bit code 'ADCVOL\_x', where 'x' is L, or R. The value "00000000" indicates mute; other values describe the number of 0.375dB steps above -71.25dB.

The ADCVOLUME bit controls the updating of digital volume control data. When ADCVOLUME is written as '0', the ADC digital volume is immediately updated with the ADCVOL\_L data when the Left ADC Digital Volume register is written. When ADCVOLUME is set to '1', the ADCVOL\_L data is held in an internal holding register until the Right ADC Digital Volume Register is written.

**4.6.1. ADC Digital Volume Control Register**

Register Address	Bit	Label	Type	Default	Description
R6 (06h) ADCVOLL	7:0	ADCVOL_L [7:0]	RW	10111111 (0dB)	Left ADC Digital Volume Control 0000 0000 = Digital Mute 0000 0001 = -71.25dB 0000 0010 = -70.875dB ... 0.375dB steps up to 1111 1111 = +24dB Note: If ADCVOLUME is set, this setting will take effect after the next write to the Right Input Volume register.
R7 (07h) ADCVOLR	7:0	ADCVOL_R [7:0]	RW	10111111 (0dB)	Right ADC Digital Volume Control 0000 0000 = Digital Mute 0000 0001 = -71.25dB 0000 0010 = -70.875dB ... 0.375dB steps up to 1111 1111 = +24dB

**Table 74. ADCVOLL/ADCVOLR Register**

**4.7. Automatic Level Control (ALC)**

The TSCS42XX has an automatic level control to achieve constant recording volume across a range of input signal levels. The device uses a digital peak detector to monitor and adjusts the PGA gain to provide a constant signal level at the ADC input. A range of adjustment between -6dB and -28.5dB (relative to ADC full scale) can be selected. The device provides programmable attack, hold, and decay times to smooth adjustments. The level control also features a peak limiter to prevent clipping when the ADC input exceeds a threshold. Note that if the ALC is enabled, the input volume controls are ignored.

### 4.7.1. ALC Operation

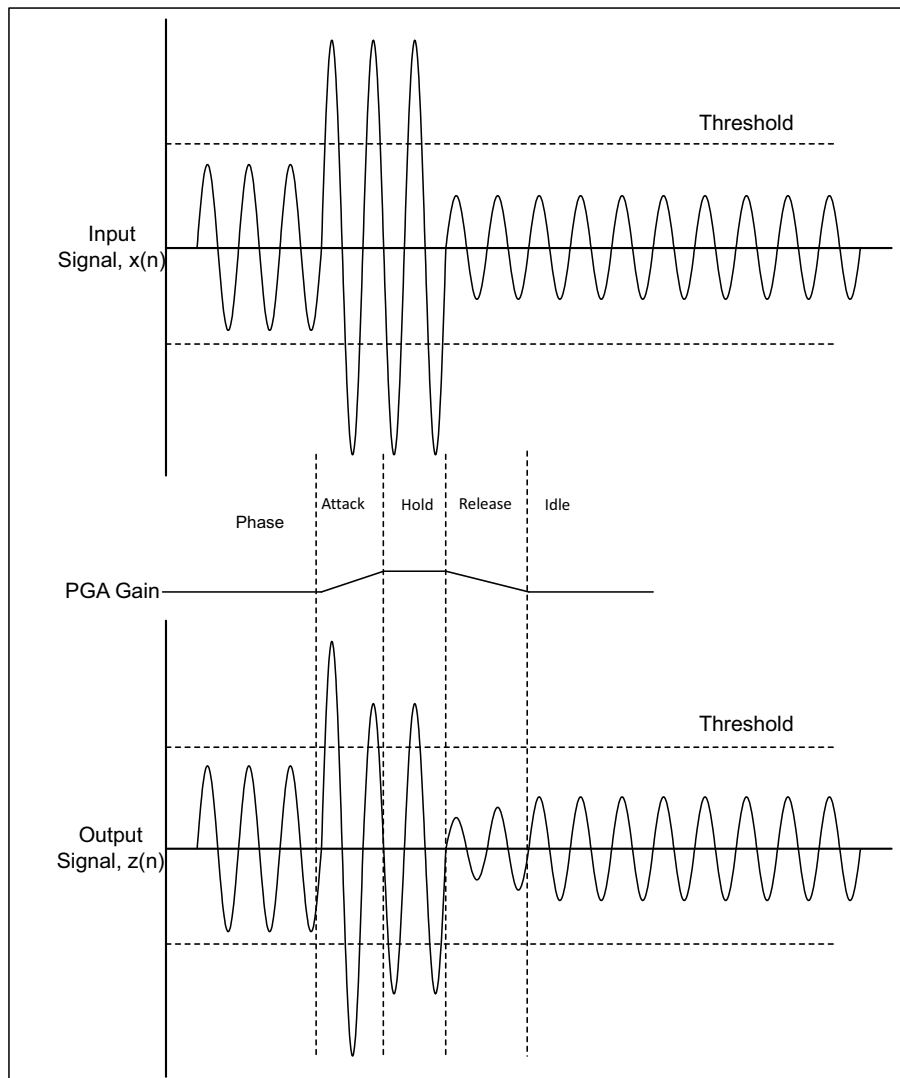

Figure 17. ALC Operation

When ALC is enabled, the recording volume target can be programmed between  $-6\text{dB}$  and  $-28.5\text{dB}$  (relative to ADC full scale). The ALC will attempt to keep the ADC input level to within  $\pm 0.5\text{dB}$  of the target level. An upper limit for the PGA gain can also be imposed, using the MAXGAIN control bits.

Hold time specifies the delay between detecting a peak level being below target, and the PGA gain beginning to ramp up. It is specified as  $2^n \times 2.67\text{mS}$ , enabling a range between  $0\text{mS}$  and over  $40\text{s}$ ; ramp-down begins immediately if the signal level is above the target.

Decay (Gain Ramp-Up) Time is the time that it takes for the PGA to ramp up across 90% of its range. The time is  $2^n \times 24\text{mS}$ . The time required for the recording level to return to its target value therefore depends on the decay time and on the gain adjustment required.

Attack (Gain Ramp-Down) Time is the time that it takes for the PGA to ramp down across 90% of its range. Time is specified as  $2^n \times 24\text{mS}$ . The time required for the recording level to return to its target value depends on both the attack time and on the gain adjustment required.

When operating in stereo, the peak detector takes the maximum of left and right channel peak values, and both PGAs use the same gain setting, to preserve the stereo image. If the ALC function is only enabled on one channel, only one PGA is controlled by the ALC mechanism, and the other channel runs independently using the PGA gain set through the control registers.

If one ADC channel is unused, the peak detector will ignore that channel.

The ALC function can operate when the two ADC outputs are mixed to mono in the digital domain or in the analog domain.

## 4.7.2. ALC Control Register

Register Address	Bit	Label	Type	Default	Description
R14 (0Eh) ALC0	7:3	RSVD	R	00000	Reserved
	2	ALC MODE	RW	0	0: ALC Mode 1: Limiter mode
	1:0	ALCSEL [1:0]	RW	00 (OFF)	ALC function select 00 = ALC off (PGA gain set by register) 01 = Right channel only 10 = Left channel only 11 = Stereo (PGA registers unused) Note: ensure that LINVOL and RINVOL settings (reg. 0 and 1) are the same before entering this mode.
R15 (0Fh) ALC1	7	RSVD	R	0	Reserved
	6:4	MAXGAIN [2:0]	RW	111 (+30dB)	Set Maximum Gain of PGA 111: +30dB 110: +24dB ...(-6dB steps) 001: -6dB 000: -12dB
	3:0	ALCL [3:0]	RW	1011 (-12dB)	ALC target – sets signal level at ADC input 0000 = -28.5dB fs 0001 = -27.0dB fs ... (1.5dB steps) 1110 = -7.5dB fs 1111 = -6dB fs
R16 (10h) ALC2	7	RSVD	R	0	Reserved
	6:4	MINGAIN	RW	000	Sets the minimum gain of the PGA 000 = -17.25db 001 = -11.25 ... 110 = +18.75dB 111 = +24.75db where each value represents a 6dB step.
	3:0	HLD [3:0]	RW	0000 (0ms)	ALC hold time before gain is increased. 0000 = 0ms 0001 = 2.67ms 0010 = 5.33ms ... (time doubles with every step) 1111 = 43.691s
R17 (11h) ALC3	7:4	DCY [3:0]	RW	0011 (192ms)	ALC decay (gain ramp-up) time 0000 = 24ms 0001 = 48ms 0010 = 96ms ... (time doubles with every step) 1010 or higher = 24.58s
	3:0	ATK [3:0]	RW	0010 (24ms)	ALC attack (gain ramp-down) time 0000 = 6ms 0001 = 12ms 0010 = 24ms ... (time doubles with every step) 1010 or higher = 6.14s

Table 75. ALC0/1/2/3 Registers

### 4.7.3. Peak Limiter

To prevent clipping, the ALC circuit also includes a limiter function. If the ADC input signal exceeds 87.5% of full scale (−1.16dB), the PGA gain is ramped down at the maximum attack rate, until the signal level falls below 87.5% of full scale. This function is automatically enabled whenever the ALC is enabled.

### 4.7.4. Input Threshold

To avoid hissing during quiet periods, the TSCS25xx has an input threshold noise gate function that compares the signal level at the inputs to a noise gate threshold. Below the threshold, the programmable gain can be held , or the ADC output can be muted. The threshold can be adjusted in increments of 1.5dB.

The noise gate activates when the signal-level at the input pin is less than the Noise Gate Threshold (NGTH) setting.

The ADC output can be muted. Alternatively, the PGA gain can be held .

The threshold is adjusted in 1.5dB steps. The noise gate only works in conjunction with the ALC, and always operates on the same channel(s) as the ALC.

### 4.7.5. Noise Gate Control Register

Register Address	Bit	Label	Type	Default	Description
R12 (12h) NGATE	7:3	NGTH [4:0]	RW	00000	Noise gate threshold (compared to ADC full-scale range) 00000 -76.5dBfs 00001 -75dBfs ... 1.5 dB steps 11110 -31.5dBfs 11111 -30dBfs
	2:1	NGG [1:0]	RW	00	Noise gate type X0 = PGA gain held constant 01 = mute ADC output 11 = reserved (do not use this setting)
	0	NGAT	RW	0	Noise gate function enable 1 = enable 0 = disable

Table 76. NGATE Register

## 5. DIGITAL AUDIO AND CONTROL INTERFACES

### 5.1. Data Interface

For digital audio data, the TSCS25xx uses six pins to input and output digital audio data.

- ADCDOUT: ADC data output
- ADCLRCLK: ADC data alignment clock
- ADCBCLK: Bit clock, for synchronization
- DACDIN: DAC data input
- DACLRCLK: DAC data alignment clock
- DACBCLK: Bit clock, for synchronization

The clock signals ADCBCLK, ADCLRCLK, DACBCLK, and DACLRCLK are outputs when the TSCS25xx operates as a master; they are inputs when it is a slave. Four different data formats are supported:

- Left justified
- Right justified
- I<sup>2</sup>S
- PCM Bluetooth

All of these modes are MSB first.

### 5.2. Master and Slave Mode Operation

The TSCS25xx can be used as either a master or slave device, selected by the MS Bit. When operating as a master, the TSCS25xx generates ADCBCLK, ADCLRCLK, DACBCLK and DACLRCLK and controls sequencing of the data transfer the data pins. In slave mode, the TSCS25xx provides data aligned to clocks it receives.

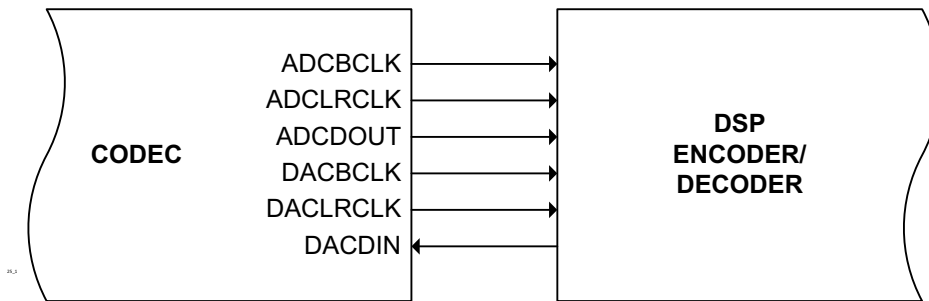

Figure 18. Master mode

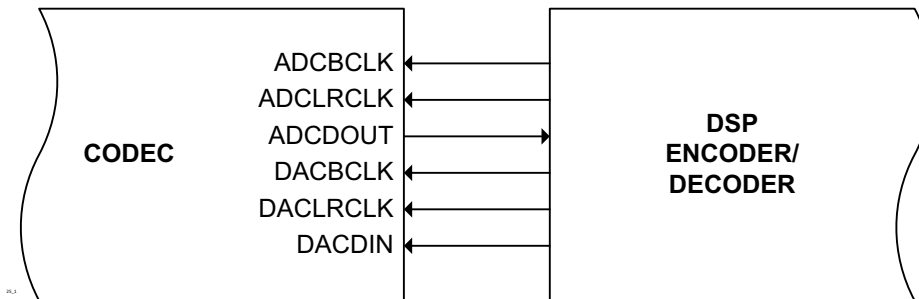

Figure 19. Slave mode

### **5.3. Audio Data Formats**

The TSCS25xx supports 4 common audio interface formats and programmable clocking that provides broad compatibility with DSPs, Consumer Audio and Video SOCs, FPGAs, handset chipsets, and many other products.

In all modes, depending on word length, BCLK frequency and sample rate, there may be unused BCLK cycles before each LRCLK transition. If the converter word length is smaller than the number of clocks per sample in the frame then the DAC will ignore (truncate) the extra bits while the ADC will zero pad the output data. If the converter word length chosen is larger than the number of clocks available per sample in the frame, the ADC data will be truncated to fit the frame and the DAC data will be zero padded.

#### **5.3.1. PCM Interface**

PCM Mode is a time-division multiplexed format. The PCM interface operates in either slave or master mode. Data is sampled on the falling edge of the bit clock and transmitted on the rising edge. A control bit selects between a delayed and non-delayed data timing relative to the start of the frame sync. The LRCLK is one bit clock long for a Short Frame Sync and one slot wide for a Long Frame Sync. PCM mode supports mono and stereo formats



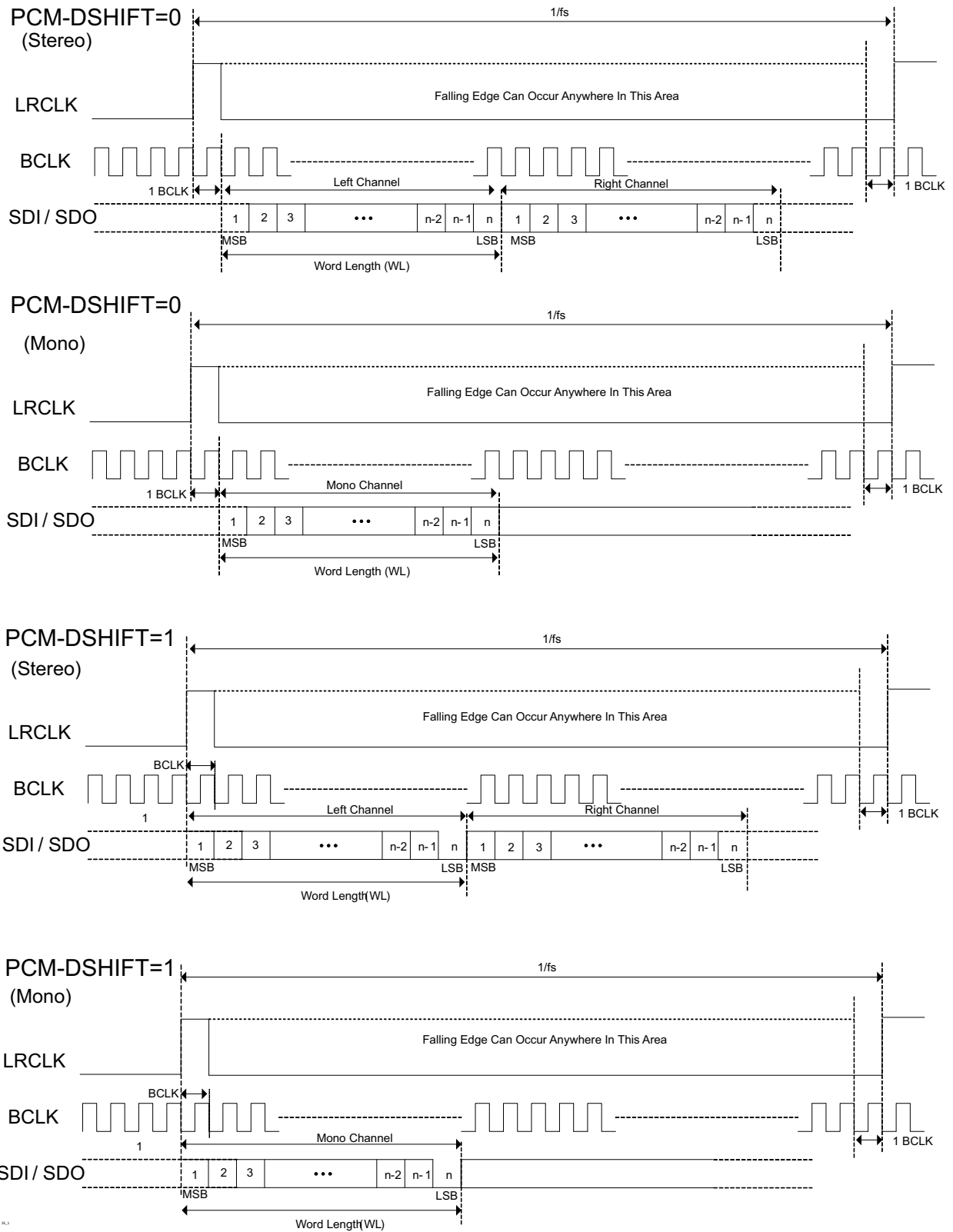

**Figure 20. PCM Audio Interface**

# TSCS25xx

## Portable Consumer CODECs

For digital audio data, the TSCS42XX uses below six pins for PCM audio interface.

- ADCDOUT: PCM data out
- ADCCLRCLK: ADC PCM data alignment
- ADCBCLK: ADC PCM Bit clock, for synchronization
- DACDIN: PCM data in
- DACLRCLK: DAC PCM data alignment
- DACBCLK: DAC PCM Bit clock, for synchronization

### 5.3.1.1. PCM control Registers

	Bit	Label	Read/Write	Reset Value	Description
R195(C3h) ADCPCMCTL1	7:5	GAINCODE	RW	0	<b>PCM gain code to be sent</b>
	4	GAINENABLE	RW	0	PCM gain code enable-if 1, replace lsb bits of data if 0, normal mode
	3	BDELAYO	RW	0	output Bit clock delay, 0 = data not delayed, 1 = data delayed.
	2	PCMFL	RW	0	PCM Frame Length in master mode, 0 = 128 bits peer frame, 1 = 256 bits per frame
	1	SLSYNC	RW	0	short-Long Frame Sync, 0 = one clock wide, 1 = one slot wide
	0		R	0	Reserved

**Table 77. ADCPCMCTL1 Register**

	Bit	Label	Read/Write	Reset Value	Description
R196(C4h) ADCPCMCTL2	7	RSVD	R	0	<b>Reserved</b>
	6	PCMMOMP	RW	0	PCM mono output mode, 0- When number of slots = 1, select left data for slot0, 1-select left data for slot0 = 1, select right data for slot0.
	5	PCMSOP	RW	0	Number of Active Slots per PCM Output Frame, 0 = one, 1 = two
	4:3	PCMDSSP	RW	0	PCM Data Slots Size, 00 = 16 bit, 01 =24 bit, 10 = 32 bit, 11=Reserved
	2		R	0	Reserved
	1		R	0	Reserved
	0		R	0	Reserved

**Table 78. ADCPCMCTL2 Register**

	Bit	Label	Read/Write	Reset Value	Description
R197(C5h) DACPCMCTL1	7:5		R	0	<b>Reserved</b>
	4		R	0	Reserved
	3	BDELAYI	RW	0	Input Bit clock delay, 0 = data not delayed, 1 = data delayed.
	2	PCMFL	RW	0	PCM Frame Length in master mode, 0 = 128 bits peer frame, 1 = 256 bits per frame
	1	SLSYNC	RW	0	short-Long Frame Sync, 0 = one clock wide, 1 = one slot wide
	0		R	0	Reserved

**Table 79. DACPCMCTL1 Register**

	Bit	Label	Read/Write	Reset Value	Description
R198(C6h) DACPCMCTL2	7	PCMFORMAT	RW	0	<b>DAC input path set to PCM format if 1</b>
	6	PCMMIM	RW	0	PCM mono input mode, 0- When number of slots = 1, select left data for slot0, 1-select left data for slot0 = 1, select right data for slot0.
	5	PCMSI	RW	0	Number of Active Slots per PCM Output Frame, 0 = one, 1 = two
	4:3	PCMDSS	RW	0	PCM Data Slots Size, 00 = 16 bit, 01 =24 bit, 10 = 32 bit, 11=Reserved
	2	PCMSIGNEXT	RW	0	Data is received in 13bit sign extended mode, left shift by 3 and pad with 0s
	1	PCM13MODE	RW	0	Data is received with un-used gain bits, set these to 0
	0		R	0	Reserved

**Table 80. DACPCMCTL2 Register**

### **5.3.2. Left Justified Audio Interface**

In Left Justified mode, the MSB is available on the first rising edge of BCLK following a LRCLK transition. The other bits are then transmitted in order. The LRCLK signal is high when left channel data is present and low when right channel data is present.

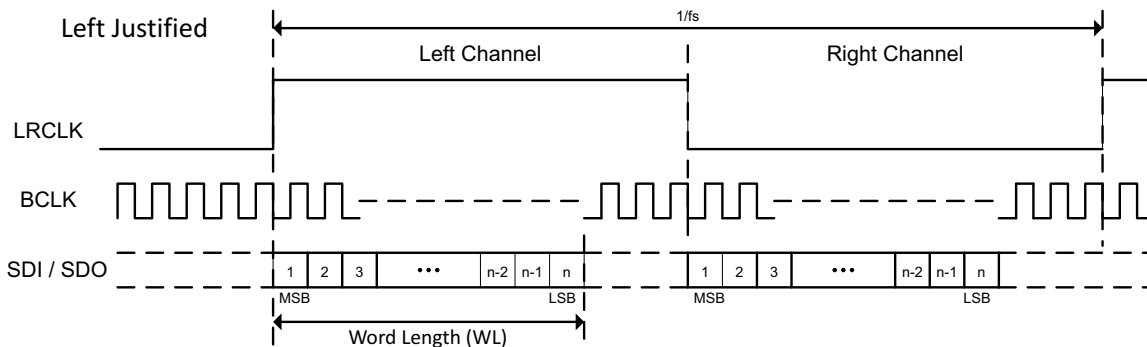

**Figure 21. Left Justified Audio Interface (assuming n-bit word length)**

**5.3.3. Right Justified Audio Interface (assuming n-bit word length)**

In Right Justified mode, the LSB is available on the last rising edge of BCLK before a LRCLK transition. All other bits are transmitted in order. The LRCLK signal is high when left channel data is present and low when right channel data is present.

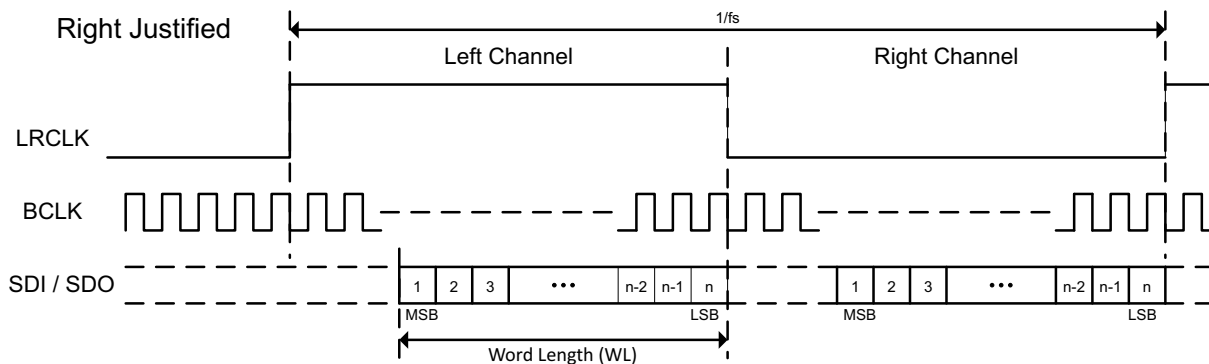

**Figure 22. Right Justified Audio Interface (assuming n-bit word length)**

**5.3.4. I<sup>2</sup>S Format Audio Interface**

In I<sup>2</sup>S mode, the MSB is available on the second rising edge of BCLK following a LRCLK transition. The other bits up to the LSB are then transmitted in order.

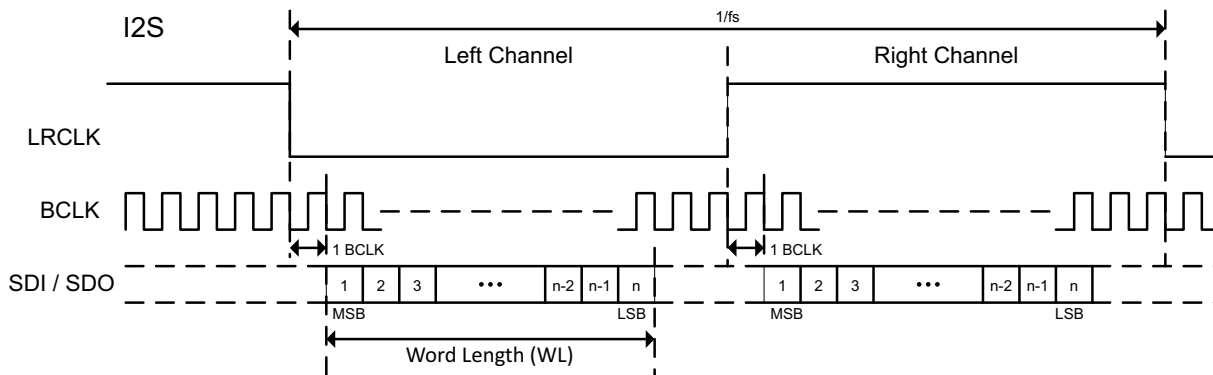

**Figure 23. I<sup>2</sup>S Justified Audio Interface (assuming n-bit word length)**

## 5.4. Audio Data Interface Registers

### 5.4.1. I2S Interface Control Registers

Register Address	Bit	Label	Default	Description
R19(13h)AIC1	7	RESERVED	0h	Reserved
	6	BCLKINV	0h	BCLK Invert (master and slave modes): 1 = BCLK inverted 0 = BCLK not inverted
	5	MS	0h	Master/Slave Control: 0 = Slave; 1 = Master
	4	LRP	0h	LRCIk Polarity: 0 = Not inverted; 1 = Inverted
	3:2	WL	2h	Audio Data Word Length: 0h = 16 bits; 1h = 20 bits; 2h = 24 bits; 3h = 32 bits
	1:0	FORMAT	2h	Audio Data Format: 0h = Right justified; 1h = Left justified; 2h = I2S 3h = Reserved

Table 81. AIC1 Register

### 5.4.2. Audio Interface Output Tri-state

TRI is used to tri-state the ADCDOUT, ADCLRCK, DACLRCLK, ADCBCLK, and DACBCLK pins. In Slave mode (MS bit=0) only ADCDOUT will be tri-stated since the other pins are configured as inputs. The Tri-stated pins are pulled low

with an internal pull-down resistor unless that resistor is disabled.

Register Address	Bit	Label	Type	Default	Description
R20 (14h) AIC2	7:6	DACDSEL[1:0]	RW	00	00: left DAC = left I2S data; right DAC = right I2S data 01: left DAC = left I2S data; right DAC = left I2S data 10: left DAC = right I2S data; right DAC = right I2S data 11: left DAC = right I2S data; right DAC = left I2S data
	5:4	ADCDSSEL[1:0]	RW	00	00: left I2S data = left ADC; right I2S data = right ADC 01: left I2S data = left ADC; right I2S data = left ADC 10: left I2S data = right ADC; right I2S data = right ADC 11: left I2S data = right ADC; right I2S data = left ADC
	3	TRI	RW	0	Tri-states ADCDOUT, ADCLRCLK, DACLRCLK, ADCBCLK, and DACBCLK pins. 0 = ADCDOUT is an output, ADCLRCLK, DACLRCLK, ADCBCLK, and DACBCLK are inputs (slave mode) or outputs (master mode) 1 = ADCDOUT, ADCLRCLK, DACLRCLK, ADCBCLK, and DACBCLK are high impedance
	2:0	BLRCM[2:0]	RW	000	Bitclock and LRclock mode. See Table Below

Table 82. AIC2 Register

**5.4.3. Bit Clock and LR Clock Mode Controls**

Although the DAC and ADC interfaces implement separate Bit Clock and LR Clock pins, it is also possible to share one or both of the clocks.

the following restrictions must be observed when the BCLK from one path (DAC or ADC) is combined with the LRCLK from the other path (ADC or DAC) as described by the Bit Clock and LR Clock Mode Selection table below:

1. Both the DAC and ADC must be programmed for the same sample rate
2. Both the DAC and ADC must be programmed for the same number of clocks per frame
3. When in slave mode, the DAC and ADC data must be aligned relative to the provided BCLK and LRCLK (this is guaranteed in master mode)
4. The DAC and ADC must be powered down when changing the BLRCM mode
5. If sharing the BCLK from one path (DAC or ADC) and the LRCLK from the other path (ADC or DAC), shut down both the DAC and ADC before programming the sample rate and clocks per frame for either. (Again, both must match.)

# TSCS25xx

## Portable Consumer CODECs

MS	BLRCM [2:0]	MODE <sup>1</sup>	DAC BCLK	ADC BCLK	DAC LRCLK	ADC LRCLK
0	000	Independent	Input for playback path	input for record path	Input for playback path	input for record path
0	001	Independent	Input for playback path	input for record path	Input for playback path	input for record path
0	010	Shared BCLK (DAC)	Input for playback and record	unused	Input for playback path	input for record path
0	011	Shared BCLK & LRCLK (DAC)	Input for playback and record	unused	Input for playback and record	unused
0	100	Shared BCLK (DAC) & LRCLK (ADC)	Input for playback and record	unused	unused	Input for playback and record
0	101	Shared BCLK (ADC)	unused	Input for playback and record	Input for playback path	input for record path
0	110	Shared BCLK (ADC) & LRCLK (DAC)	unused	Input for playback and record	Input for playback and record	unused
0	111	Shared BCLK & LRCLK (ADC)	unused	Input for playback and record	unused	Input for playback and record
1	000	Independent (off if converter off)	Output for playback path (off when DACs off) <sup>2</sup>	Output for record path (Off when ADC off) <sup>3</sup>	Output for playback path (off when DACs off)	Output for record path (off when ADCs off)
1	001	Independent (off if all converters off)	Output for playback path (off when DACs and ADCs off)	Output for record path (off when DACs and ADCs off)	Output for playback path (off when DACs and ADCs off)	Output for record path (off when DACs and ADCs off)
1	010	Shared BCLK (DAC)	Output for playback and record (stays on if either DAC or ADC on)	unused (off)	Output for playback path (Off if DAC is off)	Output for record path (off when ADCs off)
1	011	Shared BCLK & LRCLK (DAC)	Output for playback and record (stays on if either DAC or ADC on)	unused (off)	Output for playback and record (stays on if either DAC or ADC on)	unused (off)
1	100	Shared BCLK(DAC)& LRCLK(ADC)	Output for playback and record (stays on if either DAC or ADC on)	unused (off)	unused (off)	Output for playback and record (stays on if either DAC or ADC on)
1	101	Shared BCLK (ADC)	unused (off)	Output for playback and record (stays on if either DAC or ADC on)	Output for playback path (Off if DAC is off)	Output for record path (off when ADCs off)
1	110	Shared BCLK(ADC)& LRCLK(DAC)	unused (off)	Output for playback and record (stays on if either DAC or ADC on)	Output for playback and record (stays on if either DAC or ADC on)	unused (off)
1	111	Shared BCLK & LRCLK(ADC)	unused (off)	Output for playback and record (stays on if either DAC or ADC on)	unused (off)	Output for playback and record (stays on if either DAC or ADC on)

**Table 83. Bit Clock and LR Clock Mode Selection**

1. When sharing both the BCLK and LRCLK between the DAC and ADC interfaces, both the DAC and ADC must be programmed for the same rate, the same number of clocks per frame, and data must be aligned the same with respect to LRCLK. Disable all converters before changing modes.
2. DAC (playback path) is off when HPL, HPR power states are off.
3. ADC is off when ADCL, and ADCR power states are off (PGA, D2S, Boost power states are not considered.)

**5.4.4. ADC Output Pin State**

Tri-state (TRI)	Record Path Power State	ADC Data Out Pull-down (ADOPDD)	ADC Data Out State
0	Off	0	Off, pulled-low
	Off	1	Off, floating
	On	NA	Active
1	NA	0	Off, pulled-low
	NA	1	Off, floating

Table 84. ADC Data Output pin state

**5.4.5. Audio Interface Control 3 Register**

Register Address	Bit	Label	Type	Default	Description
R21 (15h) AIC3	7:6	RSVD	R	0	Reserved
	5	ADOPDD	RW	0	ADCDOUT Pull-Down Disable 0 = Pull-Down active when tri-stated or the ADC path is powered down. 1 = Pull-Down always disabled
	4	ALRPDD	RW	0	ADCLRCLK Pull-Down Disable 0 = Pull-Down active when configured as input 1 = Pull-Down always disabled
	3	ABCPDD	RW	0	ADCBCLK Pull-Down Disable 0 = Pull-Down active when configured as input 1 = Pull-Down always disabled
	2	DDIPDD	RW	0	DACDIN Pull-Down Disable 0 = Pull-Down active 1 = Pull-Down always disabled
	1	DLRPDD	RW	0	DACLCLK Pull-Down Disable 0 = Pull-Down active when configured as input 1 = Pull-Down always disabled
	0	DBCPDD	RW	0	DACBCLK Pull-Down Disable 0 = Pull-Down active when configured as input 1 = Pull-Down always disabled

Table 85. AIC3 Register

**5.4.6. Bit Clock Mode**

The default master mode bit clock generator automatically produces a bit clock frequency based on the sample rate and word length. When enabled by setting the appropriate BCM bits, the bit clock mode (BCM) function overrides the default master mode bit clock generator to produce the bit clock frequency shown below: Note that selecting a word length of 24-bits in Auto mode generates 64 clocks per frame (64fs)

Register Address	Bit	Label	Type	Default	Description
R23/R25 (17h/19h) ADCSR/DACSR	7:6	ABCM[1:0] DBCM[1:0]	RW	00	BCLK Frequency 00 = Auto 01 = 32 x fs 10 = 40 x fs 11 = 64 x fs

Table 86. ADCSR/ DACSR Register



The BCM mode bit clock generator produces 16, 20, or 32 bit cycles per sample.

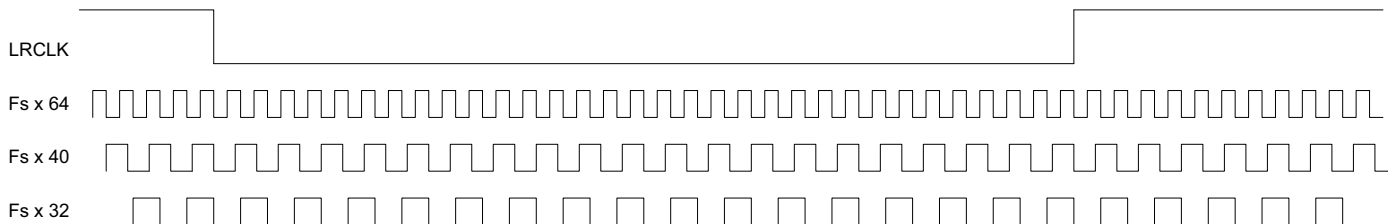

**Figure 24. Bit Clock mode**

*Note: The clock cycles are evenly distributed throughout the frame (true multiple of LRCLK not a gated clock.)*

## 5.5. I2C /Control Interface

The registers are accessed through a serial control interface using a multi-word protocol comprised of 8-bit words. The first 8 bits provide the device address and Read/Write flag. In a write cycle, the next 8 bits provide the register address; all subsequent words contain the data, corresponding to the 8 bits in each control register. The control interface operates using a standard 2-wire interface, as a slave device only. The TSCS25XX has 8 bit device address for E2.

### 5.5.1. Register Write Cycle

The controller indicates the start of data transfer with a high to low transition on SDA while SCL remains high, signalling that a device address and data will follow. All devices on the 2-wire bus respond to the start condition and shift in the next eight bits on SDIN (7-bit address + Read/Write bit, MSB first). If the device address received matches the address of the TSCS25xx and the R/W bit is '0', indicating a write, then the TSCS25xx responds by pulling SDA low on the next clock pulse (ACK); otherwise, the TSCS25xx returns to the idle condition to wait for a new start condition and valid address.

Once the TSCS25xx has acknowledged a correct device address, the controller sends the TSCS25xx register address. The TSCS25xx acknowledges the register address by pulling SDA low for one clock pulse (ACK). The controller then sends a byte of data (B7 to B0), and the TSCS25xx acknowledges again by pulling SDA low.

When there is a low to high transition on SDA while SCL is high, the transfer is complete. After receiving a complete address and data sequence the TSCS25xx returns to the idle state. If a start or stop condition is detected out of sequence, the device returns to the idle condition.

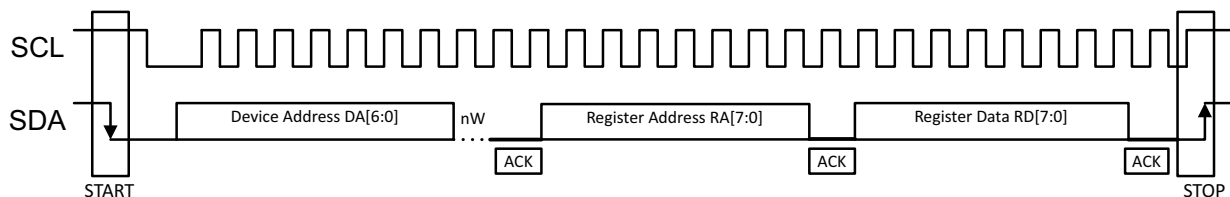

**Figure 25. 2-Wire Serial Control Interface**

### 5.5.2. Multiple Write Cycle

The controller may write more than one register within a single write cycle. To write additional registers, the controller will not generate a stop or start (repeated start) command after receiving the acknowledge for the second byte of information (register address and data). Instead the controller will continue to send bytes of data. After each byte of data is received, the register address is incremented.

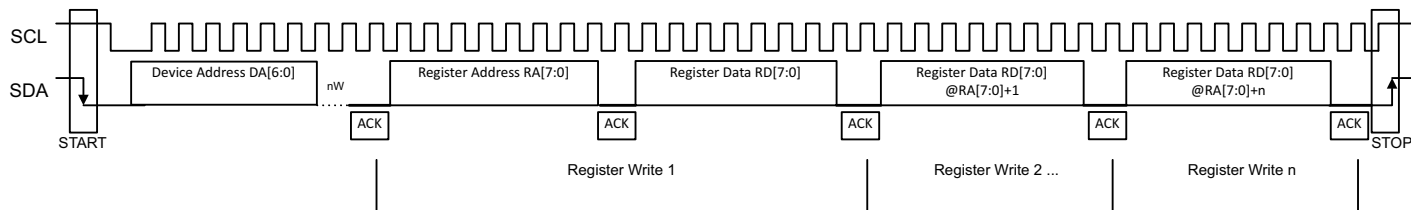

Figure 26. Multiple Write Cycle

### 5.5.3. Register Read Cycle

The controller indicates the start of data transfer with a high to low transition on SDA while SCL remains high, signalling that a device address and data will follow. If the device address received matches the address of the TSCS25xx and the R/W bit is '0', indicating a write, then the TSCS25xx responds by pulling SDA low on the next clock pulse (ACK); otherwise, the TSCS25xx returns to the idle condition to wait for a new start condition and valid address.

Once the TSCS25xx has acknowledged a correct address, the controller sends a restart command (high to low transition on SDA while SCL remains high). The controller then re-sends the devices address with the R/W bit set to '1' to indicate a read cycle. The TSCS25xx acknowledges by pulling SDA low for one clock pulse. The controller then receives a byte of register data (B7 to B0).

For a single byte transfer, the host controller will not acknowledge (high on data line) the data byte and generate a low to high transition on SDA while SCL is high, completing the transfer. If a start or stop condition is detected out of sequence, the device returns to the idle condition.

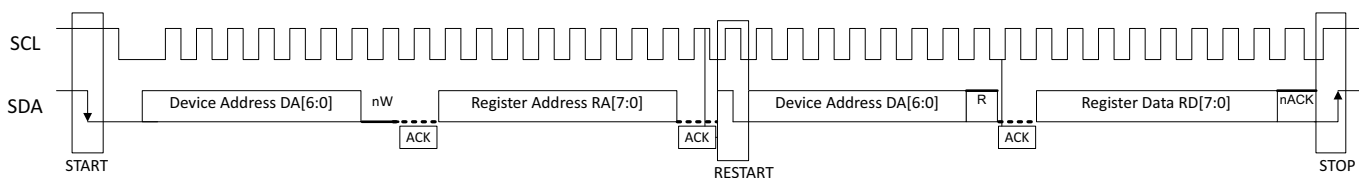
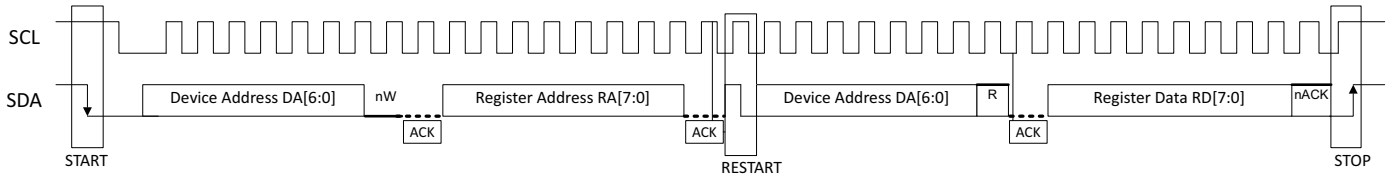

Figure 27. Read Cycle

### 5.5.4. Multiple Read Cycle

The controller may read more than one register within a single read cycle. To read additional registers, the controller will not generate a stop or start (repeated start) command after sending the acknowledge for the byte of data. Instead the controller will continue to provide clocks and acknowledge after each byte of received data. The codec will automatically increment the internal register address after each register has had its data successfully read (ACK from host) but will not increment the register address if the data is not received correctly by the host (nACK from host) or if the bus cycle is terminated unexpectedly (however the EQ/Filter address will be incremented even if the register address is not incremented when performing EQ/Filter RAM reads). By automatically incrementing the internal register address after each

byte is read, all the internal registers of the codec may be read in a single read cycle.



**Figure 28. Multiple Read Cycle**

### **5.5.5. Device Addressing and Identification**

The TSCS25xx has a default slave address of E2. However, it is sometimes necessary to use a different address. The TSCS25xx has a device address register for this purpose. The part itself has an 8-bit Identification register and an 8-bit revision register that provide device specific information for software. In addition, an 8-bit programmable subsystem ID register can allow firmware to provide a descriptive code to higher level software such as an operating system driver or application software.

*5.5.5.1. Device Address Register*

Register Address	Bit	Label	Type	Default	Description
R124 (7Ch) DEVADR	7:1	ADDR[7:1]	RW	1110001	7-bit slave address
	0	RSVD	R	0	

**Table 87. DEVADR Register**

*5.5.5.2. Device Identification Registers*

Register Address	Bit	Label	Type	Default	Description
R126 (7Eh) DEVIDH	7:0	DID[15:8]	R	xxh	16-bit device identification number. Contact TSI.
R125 (7Dh) DEVIDL	7:0	DID[7:0]	R	xxh	

**Table 88. DEVID H&L Registers**

**5.5.6. Device Revision Register**

Register Address	Bit	Label	Type	Default	Description
R127 (7Fh) REVID	7:4	MAJ[3:0]	R	xh	4-bit major revision number. Contact TSI.
	3:0	MNR[3:0]	R	xh	4-bit minor revision number. Contact TSI.

**Table 89. REVID Register**

**5.5.7. Register Reset**

The TSCS25xx registers may be reset to their default values using the reset register. Writing a special, non-zero value to this register causes all other registers to assume their default states. Device status bits will not necessarily change their values depending on the state of the device.

Register Address	Bit	Label	Type	Default	Description
R128 (80h) RESET	7:0	Reset[7:0]	RW	00h	Reset register Writing a value of 85h will cause registers to assume their default values. Reading this register returns 00h

**Table 90. RESET Register**

## 6. GPIO'S

Two GPIO's are available on the GPIO1-GPIO0 pins. These GPIO pins are accessed via register bits. The general-purpose input/output (GPIO) pins can be used as either inputs or outputs. These pins are readable and can be set or read through the control interface. These pins are useful for interfacing to external hardware.

### 6.1. GPIO Usage Summary

GPIO Pin	Function 1	Function 2	Pull-Up Pull-Down
GPIO0	GPIO0 Register Bit	RSVD	Pull-Up
GPIO1	GPIO1 Register Bit	RSVD	Pull-Up

Table 91. GPIO Pin Usage Summary

### 6.2. GPIO Control Registers

#### 6.2.1. GPIO Control 1 Register

Register Address	Bit	Label	Type	Default	Description
Reg192 (C0h) GPIOCTL1	7	RESERVED	R	0	Reserved
	6	RESERVED	R	0	Reserved
	5	GPIO1CFG	RW	0	GPIO1 Configuration 0 = GPIO1 Configured as Input/Output 1 = GPIO1 Configured as Interrupt
	4	GPIO0CFG	RW	0	GPIO0 Configuration 0 = GPIO0 Configured as Input/Output 1 = GPIO0 Configured as Interrupt
	3	RESERVED	R	0	Reserved
	2	RESERVED	R	0	Reserved
	1	GPIO1DIR	RW	0	GPIO1 Input/Output 0 = GPIO1 configured as input 1 = GPIO1 configured as output
	0	GPIO0DIR	RW	0	GPIO0 Input/Output 0 = GPIO0 configured as input 1 = GPIO0 configured as output

Table 92. GPIOCTL1 Register

**6.2.2. GPIO Control 2 Register**

Register Address	Bit	Label	Type	Default	Description
Reg 193 (C1h) GPIOCTL2	7:2	RESERVED	R	0	Reserved
	1	GPIO1PU	R	0	GPIO1 Pull up 0 = GPIO1 pull up enabled 1 = GPIO1 pull up disabled
	0	GPIO0PU	R	0	GPIO0 Pull up 0 = GPIO0 pull up enabled 1 = GPIO0 pull up disabled

**Table 93. GPIOCTL2 Register**

**7. CLOCK GENERATION**

The TSCS42XX uses two PLL's to generate two high frequency reference clocks. The clock frequencies of each reference clock are based on multiples of 44.1KHz and 48KHz sample rates. The clock source for the PLL's can be the MCLK2 pin or one of the I2S interface BCLK inputs. The clock source reference is set in register 8F. Each PLL can be independently powered down if the audio sample rates generated by that particular PLL are not required.

**7.1. On-Chip PLLs**

The TSCS42XX generates two high-quality, high-frequency clocks 122.880MHz and 112.896MHz. The PLL support a wide range of input clock frequencies. Some typical frequencies are 19.2Mhz, 22MHz, 22.5792MHz, 24MHz, 24.576 MHz, 27MHz, and 36MHz. It should be noted that some input clock frequencies may not result in being able to generate the 122.880MHz and 112.896Mhz clocks exactly resulting in an error in the audio sample rate.

Audio Clocks - Each PLL generates one of two clock frequencies based on two audio sample rates.

- 122.880 MHz (2560 x 48 KHz)
- 112.896 MHz (2560 x 44.1 KHz)

It is important that the needed PLLs remain on until all audio functions, including jack detection, are disabled.

The MCLK2 pin is configured to input a high frequency clock from an external oscillator or other external clock source.

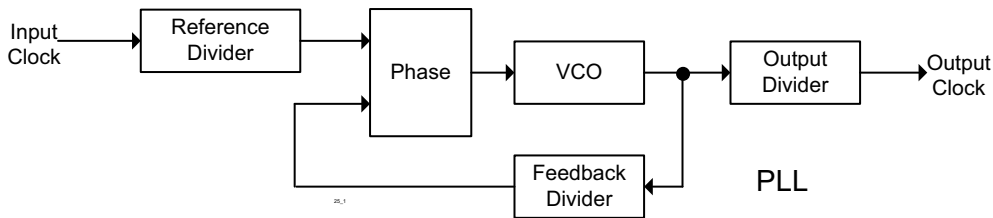

**Figure 29. PLL Block Diagram**

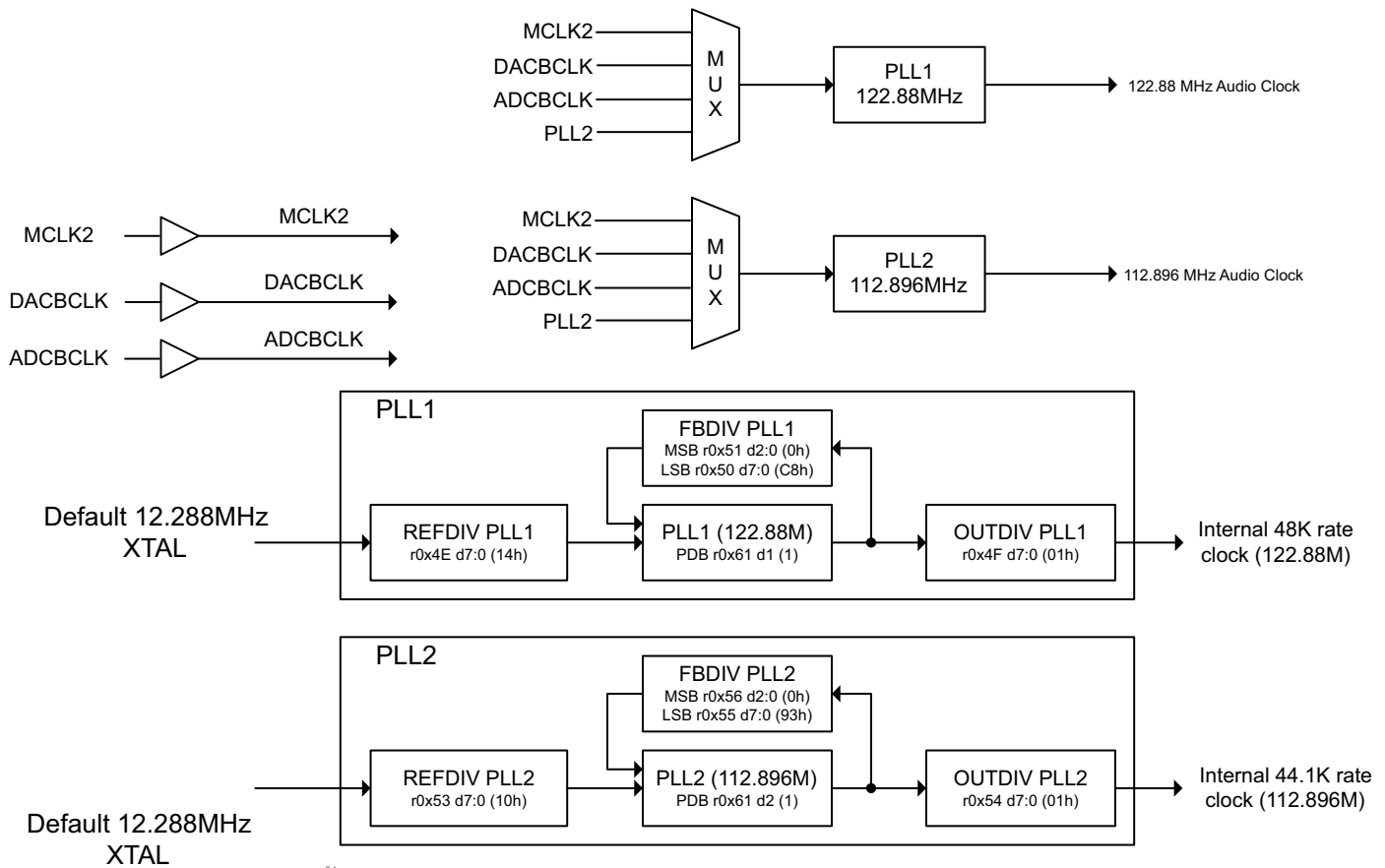

**Figure 30. System Clock Diagram**

## 7.2. System Clock Generation

The TSCS25xx supports an internal clock and audio sample rate that is selectable between 11.025KHz, 12 KHz, 22.050KHz, 24KHz, 44.1KHz, 48KHz, 88.2KHz, and 96KHz. One bi-directional stereo I2S interfaces is available. In Master mode an internal timing generator is used to specify the audio sample rate. The sample rate specified in Master mode is independent from the internal clock rate.and the specified range is 8KHz to 96KHz. A variety of sample rates based on 44.1K, 48K and 32K are supported. A highly programmable PLL enables just about any input frequency to be used.

### 7.2.1. PLL Dividers

The chosen input frequency is multiplied up by the PLL's to generate the required output frequencies; 122.88MHz and 112.896MHz. It should be noted that it may not always be possible to generate the required output frequencies with zero error. Some values for the PLL dividers relative a specific input frequency are shown in the table below.



# TSCS25xx

## Portable Consumer CODECs

### OUTPUT FREQUENCY

CLK Input MHz	Time-Base	PLL1 Default Power (122.88MHz)							PLL2 Default Power (112.896MHz)						
		52h	60h	4Eh	4Fh	50h	51h	Fvc0	57h	60h	53h	54h	55h	56h	Fvc0
0.51200	0x01	0x02	0x00	0x00	0x03	0x00	0x00	368.64	0x00	0x10	0x01	0x04	0x00	0x00	451.58
0.70560	0x02	0x02	0x04	0x01	0x03	0x01	0x00	368.68	0x02	0x10	0x01	0x04	0x08	0x00	451.58
1.02400	0x03	0x02	0x04	0x02	0x03	0x0D	0x00	368.64	0x01	0x10	0x02	0x04	0x07	0x00	451.58
1.41120	0x05	0x03	0x04	0x07	0x02	0x0C	0x03	245.75	0x01	0x10	0x03	0x03	0x0D	0x00	338.69
1.53600	0x05	0x01	0x00	0x00	0x03	0x0E	0x00	368.64	0x01	0x10	0x02	0x03	0x0B	0x00	338.69
2.04800	0x07	0x02	0x00	0x00	0x03	0x0D	0x00	368.64	0x01	0x10	0x04	0x04	0x07	0x00	451.58
2.40000	0x08	0x02	0x04	0x05	0x03	0x00	0x03	368.64	0x02	0x10	0x05	0x05	0x09	0x00	564.48
2.82240	0x0A	0x03	0x04	0x07	0x04	0x0C	0x03	491.5	0x02	0x10	0x05	0x03	0x05	0x00	338.69
3.07200	0x0B	0x02	0x04	0x07	0x03	0x04	0x00	368.64	0x01	0x10	0x04	0x03	0x0B	0x00	338.69
5.64480	0x15	0x03	0x04	0x0E	0x04	0x03	0x04	491.5	0x01	0x10	0x08	0x03	0x0E	0x00	338.69
6.14400	0x17	0x01	0x00	0x00	0x03	0x0E	0x00	368.64	0x01	0x10	0x08	0x03	0x0B	0x00	338.69
12.00000	0x2E	0x01	0x00	0x01	0x03	0x00	0x03	368.64	0x02	0x10	0x19	0x05	0x09	0x00	564.48
		0x0B	0x04	0x09		0x00	0x03		0x0A				0x08		

TSCS25xx

Portable Consumer CODECs

12.28 800	0x2F	0 x 1 A	0 x 0 4	0 x 1 2	0x 03	0 x 1 C	0 x 0 2	368. 64	0 x 2 2	0x 10	0x 20	0x 03	0 x 7 2	0 x 0 3	338. 69
19.20 000	0x4A	0 x 1 3	0 x 0 4	0 x 1 4	0x 03	0 x 8 0	0 x 0 1	368. 64	0 x 1 A	0x 10	0x 19	0x 03	0 x B 9	0 x 0 1	338. 69
22.00 000	0x55	0 x 2 A	0 x 0 4	0 x 3 7	0x 05	0 x 0 0	0 x 0 6	614. 4	0 x 2 2	0x 10	0x 26	0x 03	0 x 4 9	0 x 0 2	338. 68
22.57 920	0x57	0 x 2 2	0 x 0 4	0 x 3 1	0x 03	0 x 2 0	0 x 0 3	368. 64	0 x 1 A	0x 10	0x 1D	0x 03	0 x B 3	0 x 0 1	338. 69
24.00 000	0x5D	0 x 1 3	0 x 0 4	0 x 1 9	0x 03	0 x 8 0	0 x 0 1	368. 64	0 x 1 B	0x 10	0x 19	0x 05	0 x 4 C	0 x 0 2	564. 48
24.57 600	0x5F	0 x 1 3	0 x 0 4	0 x 1 D	0x 03	0 B 3	0 x 0 1	368. 64	0 x 2 2	0x 10	0x 40	0x 03	0 x 7 2	0 x 0 3	338. 69
25.00 000	0x61	0 x 1 B	0 x 0 4	0 x 3 7	0x 03	0 x 2 B	0 x 0 3	368. 64	0 x 1 A	0x 10	0x 2A	0x 03	0 x 3 9	0 x 0 2	338. 69
26.00 000	0x65	0 x 2 3	0 x 0 4	0 x 4 1	0x 05	0 x 0 0	0 x 0 6	614. 4	0 x 1 A	0x 10	0x 26	0x 03	0 x E F	0 x 0 1	338. 68
27.00 000	0x68	0 x 2 2	0 x 0 4	0 x 4 B	0x 03	0 x 0 0	0 x 4 4	368. 64	0 x 2 A	0x 10	0x 7D	0x 03	0 x 2 0	0 x 0 6	338. 69
36.00 000	0x8C	0 x 1 B	0 x 0 4	0 x 4 B	0x 03	0 x 0 0	0 x 3 3	368. 64	0 x 2 A	0x 10	0x 7D	0x 03	0 x 9 8	0 x 0 4	338. 69
40.00 000	0x9B	0 x 2 2	0 x 0 8	0 x 7 D	0x 03	0 x 8 0	0 x 0 4	368. 64	0 x 2 3	0x 10	0x 7D	0x 05	0 x E 4	0 x 0 6	564. 48

Table 94. Typical PLL Divider Value

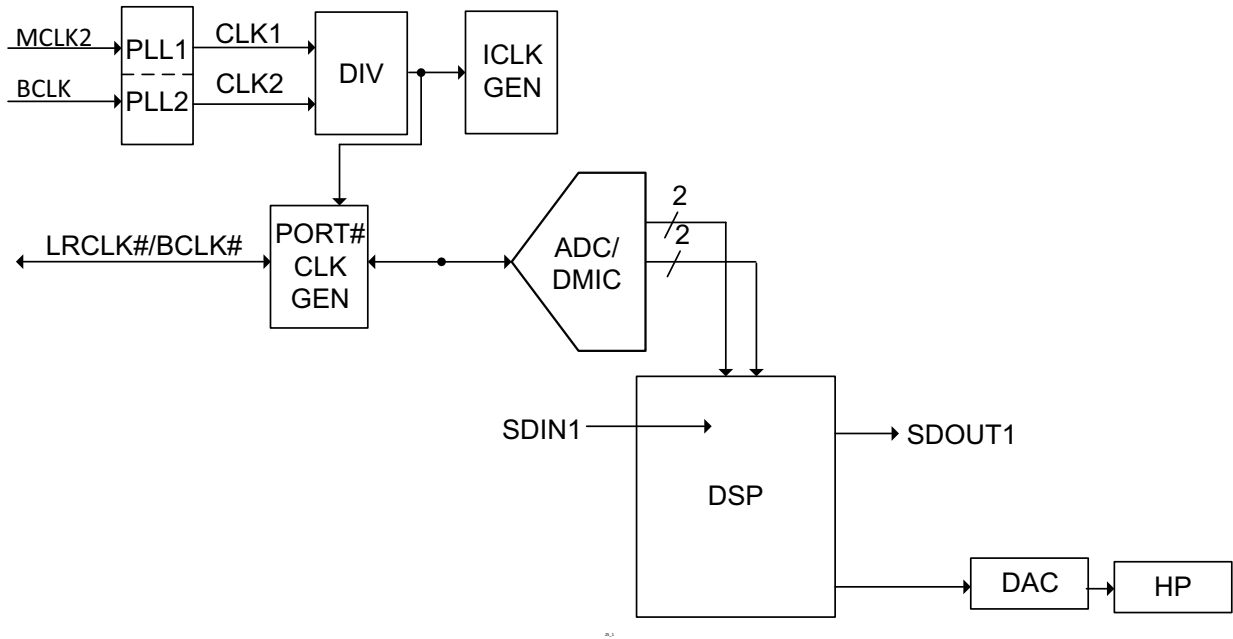

Figure 31. Simplified System Clock Block Diagram

## 7.2.1.1. PLL Control Register

Register Address	Bit	Label	Type	Default	Description
R96(60h) PLLCTL1B	7:6	RSVD	R	0h	Reserved
	5:4	VCOI_PLL2	RW	1h	PLL2 VCO/ICO current setting
	3:2	VCOI_PLL1	RW	1h	PLL1 VCO/ICO current setting
	1:0	RSVD	R	0h	Reserved

Table 95. PLLCTL1B Register

## 7.2.1.2. PLL Status Register

Register Address	Bit	Label	Type	Default	Description
R142(8Eh) PLLCTL0	7:2	RSVD	R	00h	Reserved
	1	PLL2LK	R	0h	1 = PLL2 has obtained lock
	0	PLL1LK	R	0h	1 = PLL1 has obtained lock

Table 96. PLLCTL0 Register

## 7.2.1.3. PLL Reference Register

Register Address	Bit	Label	Type	Default	Description
R143(8Fh) PLLREFSEL	7	RSVD	R	0h	Reserved
	6:4	PLL2_REF_SEL	RW	0h	PLL2 Reference Mux, 000 = reserved; 001 = mclk2; 010 = dac_bclk; 011 = adc_bclk; 100 = pll1 output; 101 - 111 = reserved
	3	RSVD	R	0h	Reserved
	2:0	PLL1_REF_SEL	RW	0h	PLL1 Reference Mux, 000 = reserved; 001 = mclk2; 010 = dac_bclk; 011 = adc_bclk; 100 = pll2 output; 101 - 111 = reserved

Table 97. PLLREFSEL Register

## 7.2.1.4. PLL1 Control Register

Register Address	Bit	Label	Type	Default	Description
R82(52h) PLLCTLD	7:5	RSVD	R	0	Reserved
	4:3	RZ_PLL1	RW	3h	PLL1 Zero R setting
	2:0	CP_PLL1	RW	2h	PLL1 main charge pump current setting

Table 98. PLLCTLD Register

7.2.1.5. *PLL1 Reference Clock Divider Register*

Register Address	Bit	Label	Type	Default	Description
R78(4Eh) PLLCTL9	7:0	REFDIV_PLL1	RW	19h	PLL1 refclk divider

**Table 99. PLLCTL9 Register**

7.2.1.6. *PLL1 Output Divider Register*

Register Address	Bit	Label	Type	Default	Description
R79(4Fh) PLLCTLA	7:0	OUTDIV_PLL1	RW	03h	PLL1 output divider

**Table 100. PLLCTLA Register**

7.2.1.7. *PLL1 Feedback Divider Low Register*

Register Address	Bit	Label	Type	Default	Description
R80(50h) PLLCTLB	7:0	FBDIVL_PLL1	RW	80h	PLL1 feedback divider

**Table 101. PLLCTLB Register**

7.2.1.8. *PLL1 Feedback Divider High Register*

Register Address	Bit	Label	Type	Default	Description
R81(51h) PLLCTLC	7:3	RSVD	R	0	Reserved
	2:0	FBDIVH_PLL1	RW	1h	PLL1 feedback divider

**Table 102. PLLCTLC Register**

7.2.1.9. PLL2 Control Register

Register Address	Bit	Label	Type	Default	Description
R87(57h) PLLCTL12					
	7:6		R	0	Reserved
	5:3	RZ_PLL2	RW	3h	PLL2 Zero R setting
	2:0	CP_PLL2	RW	2h	PLL2 main charge pump current setting

Table 103. PLLCTL12 Register

7.2.1.10. PLL2 Reference Clock Divider Register

Register Address	Bit	Label	Type	Default	Description
R83(53h) PLLCTLE	7:0	REFDIV_PLL2	RW	12h	PLL2 reference clock divider

Table 104. PLLCTLE Register

7.2.1.11. PLL2 Output Divider Register

Register Address	Bit	Label	Type	Default	Description
R84(54h) PLLCTLEF	7:0	OUTDIV_PLL2	RW	03h	PLL2 output divider

Table 105. PLLCTLEF Register

7.2.1.12. PLL2 Feedback Divider Low Register

Register Address	Bit	Label	Type	Default	Description
R85(55h) PLLCTL10	7:0	FBDIVL_PLL2	RW	1ch	PLL2 feedback low divider

Table 106. PLLCTL10 Register

7.2.1.13. PLL2 Feedback Divider High Register

Register Address	Bit	Label	Type	Default	Description
R86(56h) PLLCTL11	7:3	RSVD	R	0	Reserved
	2:0	FBDIVH_PLL2	RW	2h	PLL2 feedback high divider

Table 107. PLLCTL11 Register

## 7.2.1.14. PLL Pwer DownControl Register

Register Address	Bit	Label	Type	Default	Description
R97(61h) PLLCTL1C	7:3	RESERVED	R	0h	Reserved
	2	PDB_PLL2	RW	0h	PLL2 Power Down: 1 = Power Up 0 = Power Down
	1	PDB_PLL1	RW	0h	PLL1Power down 1 = Power Up 0 = Power Down
	0	RESERVED	R	0h	Reserved

Table 108. PLLCTL1C Register

## 7.2.2. PLL Power Down Control

Each PLL can be powered down to save power if only one set of base audio rates is required. The base audio rates are defined as 44.1KHz based rates or 48KHz based rates. If support for either 44.1KHz or 48KHz based rates is not needed then the PLL associated with the unused rate can be powered down.

## 7.2.3. Audio Clock Generation

Figure 33 shows the simplified block diagram. The TSCS42XX utilizes internal PLLs to generate the PLL clocks at 112.896 MHz (22.5792MHz \*5) and 122.880 MHz (24.576 \*5). Intermediate clocks (61.44MHz, 40.96MHz, 56.448MHz) are then generated which are then used to generate the audio sample rates. There is one internal clock rate that can be specified to operate at 11.025KHz, 12 KHz, 22.050KHz, 24KHz, 44.1KHz, 48KHz, 88.2KHz, and 96KHz. When changing sample rates a delay of up to 5mS may be needed for the part to properly lock PLLs, flush filters, etc.

## 7.2.3.1. PLL Clock Source

The clock source for the PLL can be selected from the MCLK2 pin or one of the I2S BCLK inputs via a selectable mux.

7.2.3.2. Internal Sample Rate Control Register

These register define the internal sample rate.

Register Address	Bit	Label	Default	Description
R23(17h) ADCSR	7:6	ABCM	0h	ADC bit Clock Mode (for ADCBCLK generation in master mode): 0h=Auto 1h = 32x Fs 2h = 40x Fs 3h = 64x Fs
	5	RSVD	0h	Reserved
	4:3	ABR	2h	ADC Base Rate 0h = 32kHz 1h = 44.1kHz 2h = 48KHz 3h = Reserved
	2:0	ABM	2h	ADC Base Rate Multiplier 0h = 0.25x 1h = 0.5x 2h = 1x 3h = 2x 4h-7h = Reserved

Table 109. ADCSR Register

Register Address	Bit	Label	Default	Description
R25 (19h) DACSR	7:6	DBCM	0h	DAC bit Clock Mode (for DACBCLK generation in master mode): 0h=Auto 1h = 32x Fs 2h = 40x Fs 3h = 64x Fs
	5	RSVD	0h	Reserved
	4:3	DBR	2h	DAC Base Rate 0h = 32kHz 1h = 44.1kHz 2h = 48KHz 3h = Reserved
	2:0	DBM	2h	DAC Base Rate Multiplier 0h = 0.25x 1h = 0.5x 2h = 1x 3h = 2x 4h-7h = Reserved

Table 110. DACSR Register



**Internal Sample Rates**

xBR [4:3]	xBM [2:0]	BASE RATE	SAMPLE RATE
00	000	40.96MHz	8kHz(MCLK/5120)
	001		16kHz(MCLK/2560)
	010		32 kHz (MCLK/1280)
	011		64kHz (MCLK/640)
01	000	56.448MHz	11.025kHz(MCLK/5120)
	001		22.050kHz(MCLK/2560)
	010		44.1 kHz (MCLK/1280)
	011		88.2 kHz (MCLK/640)
10	000	61.44 MHz	12kHz(MCLK/5120)
	001		24kHz(MCLK/2560)
	010		48 kHz (MCLK/1280)
	011		96 kHz (MCLK/640)

**Table 111. DAC/ADC Sample rates**

**7.2.3.3. MCLK2 Pin**

The MCLK2 pin is configured to be an input and can provide a clock to drive the input to the PLLs or the I2S Master Mode clock generators.

**7.2.3.4. I2S Master Mode Clock Generation**

I2S input audio source can operate as a timing Slave or Master. When operated in Master Mode an internal clock generator is used to produce the required bit and frame clocks to be driven out of the LRCLK and BCLK pins of each input I2S interface. The clock source for the I2S master clock generation can be selected between the PLL generated internal timing or an externally supplied clock via the MCLK2 input.

**7.2.3.5. I2S Master Mode Sample Rate Control**

I2S slave or master mode is set in register 13 MS bit. The I2S BR bits set the base audio sample to be either 44.1Khz or 48KHz. The I2S BM bits are then used to set the base rate multiplier ratio. The I2S BCM bits set the BCLK ratio vs sample rate. The I2S BR, BM and BCM bits are located in register 17h for the ADC while register 19h for the DAC.

**7.2.3.6. DAC/ADC Clock Control**

The power consumption and audio quality may be adjusted by changing the converter modulator rate. By default the DAC and ADC Sigma-Delta modulators run at the specified OSR rates for the best audio quality. The modulator rates for the converters may be forced to run at half their nominal OSR rates to conserve power. A third option allows the modulator rate to automatically drop to half rate when low sampling rates are chosen (1/2 or 1/4 the base rate.) The DACs and ADCs are independently controlled

# TSCS25xx

## Portable Consumer CODECs

Register Address	Bit	Label	Type	Default	Description
R31(1Fh) CONFIG0	7:6	ASDM[1:0]	RW	2h	ADC Modulator Rate 00b = Reserved 01b = Half 10b = Full 11b = Auto
	5:4	DSDM[1:0]	RW	2h	DAC Modulator Rate 00b = Reserved 01b = Half 10b = Full 11b = Auto
	3:2	RSVD	R	0	Reserved
	1	DC_BYPASS	RW	0h	DAC DC Filter Bypass: 0 = Filter enable 1 = Filter bypassed
	0	SD_FORCE_ON	RW	0h	Supply Detect Force On: 0 = Supply detect not forced on 1 = Supply detect forced on  Note If not forced on, the supply detect logic will automatically be enabled when features that use it are enabled (COP,UVLO)

Table 112. CONFIG0 Register

DSDM[1:0] ASDM[1:0]	BM [2:0]	Modulator Rate
00	NA	Reserved
01	000 (1/4x)	Half
	001 (1/2x)	
	010 (1x)	
	011 (2x)	
10	000 (1/4x)	Full
	001 (1/2x)	
	010 (1x)	
	011 (2x)	
11	000 (1/4x)	Auto (Half)
	001 (1/2x)	Auto (Half)
	010 (1x)	Auto (Full)
	011 (2x)	Auto (Full)

**Table 113. ADC and DAC Modulator Rates**

7.2.3.7. *Timebase Register*

Register Address	Bit	Label	Type	Default	Description
R119(77h) TMBASE	7-0	TIMEBASE[7:0]	RW	2F	Internal Time Base Divider. This value should be programmed as $[\text{round}(\text{ref clock}/256000)]-1$

**Table 114. TIMEBASE Register**

## 8. CHARACTERISTICS

### 8.1. Electrical Specifications

#### 8.1.1. Absolute Maximum Ratings

Stresses above the ratings listed below can cause permanent damage to the TSCS25xx. These ratings, which are standard values for TSI commercially rated parts, are stress ratings only. Functional operation of the device at these or any other conditions above those indicated in the operational sections of the specifications is not implied. Exposure to absolute maximum rating conditions for extended periods can affect product reliability. Electrical parameters are guaranteed only over the recommended operating temperature range.

Item	Maximum Rating
Voltage on any pin relative to Ground	V <sub>ss</sub> - 0.3V TO V <sub>dd</sub> + 0.3V
Operating Temperature	0 °C TO 70 °C
Storage Temperature	-55 °C TO +125 °C
Soldering Temperature	260 °C
MICBias Output Current	3mA
Amplifier Maximum Supply Voltage	6 Volts = PVDD
Audio Maximum Supply Voltage	3 Volts = AVDD/CPVDD
Digital I/O Maximum Supply Voltage	3.6 Volts = DVDD_IO
Digital Core Maximum Supply Voltage	2.0 Volts = DVDD

Table 115. Electrical Specification: Maximum Ratings

#### 8.1.2. Recommended Operating Conditions

Parameter		Min.	Typ.	Max.	Units
Power Supplies	DVDD_Core	1.4		2.0	V
	DVDD_IO	1.4		3.5	
	AVDD/CPVDD	1.7		2.0	
	PVDD	3.0		5.5	V
Ambient Operating Temperature	Analog - 5 V	0	25	70	°C
Case Temperature	T <sub>case</sub>			90	°C

Table 116. Recommended Operating Conditions

**ESD:** The TSCS25xx is an ESD (electrostatic discharge) sensitive device. The human body and test equipment can accumulate and discharge electrostatic charges up to 4000 Volts without detection. Even though the TSCS25xx implements internal ESD protection circuitry, proper ESD precautions should be followed to avoid damaging the functionality or performance.

## 8.2. Device Characteristics

( $T_{\text{ambient}} = 25\text{ }^{\circ}\text{C}$ ,  $\text{DVDD\_CORE}=\text{DVDD\_IO}=\text{AVDD}=1.9\text{V}$ ,  $\text{PVDD}=3.6\text{V}$ , 997Hz signal,  $f_s=48\text{KHz}$ , Input Gain=0dB, 24-bit audio)

Parameter	Symbol	Test Conditions	Min	Typ	Max	Unit
<b>Analog Inputs (<math>L_{\text{IN}1}</math>, <math>L_{\text{IN}2}</math>, <math>R_{\text{IN}1}</math>, <math>R_{\text{IN}2}</math>)</b>						
Full Scale Input Voltage	$V_{\text{FSIV}}$	L/ $R_{\text{IN}1,2}$ Single Ended		0.5 -6		Vrms dBV
		L/ $R_{\text{IN}1,2}$ Differential Mic		0.5 -6		Vrms dBV
Input Impedance				50		Kohm
Input Capacitance				10		pF
<b>Analog Input Boost Amplifier</b>						
Programmable Gain Min				0.0		dB
Programmable Gain Max				30.0		dB
Programmable Gain Step Size				10.0		dB
<b>Analog Input PGA</b>						
Programmable Gain Min				-17.25		dB
Programmable Gain Max				30.0		dB
Programmable Gain Step Size		Guaranteed Monotonic		0.75		dB
<b>Digital Volume Control Amplifier</b>						
Programmable Gain Min				-97		dB
Programmable Gain Max				30.0		dB
Programmable Gain Step Size		Guaranteed Monotonic		0.5		dB
Mute Attenuation				-999		dB
<b>Analog Inputs (<math>L_{\text{IN}1}/R_{\text{IN}1}</math>, <math>L_{\text{IN}2}/R_{\text{IN}2}</math> Differential) to ADC</b>						
Signal To Noise Ratio	SNR	A-weighted 20-20KHz		90		dB
Total Harmonic Distortion + Noise	THD+N	-1dBFS input		-80 0.01		dB %
<b>Analog Inputs (<math>L_{\text{IN}1}</math>, <math>L_{\text{IN}2}</math>, <math>R_{\text{IN}1}</math>, <math>R_{\text{IN}2}</math> Single Ended) to ADC</b>						
Signal To Noise Ratio	SNR	A-weighted 20-20KHz		90		dB
Total Harmonic Distortion + Noise	THD+N	-1dBFS input		-80 0.01		dB %
ADC channel Separation		997Hz full scale signal		70		dB
Channel Matching		997Hz signal			2	%
<b>DAC to Line-Out (HPL, HPR with 10K / 50pF load)</b>						
Signal to Noise Ratio <sup>1</sup>	SNR	A-weighted		102		dB
Total Harmonic Distortion +Noise <sup>2</sup>	THD+N	997Hz full scale signal		-84		dB
Channel Separation		997Hz full scale signal		70		dB
Mute attenuation				-999		dB
<b>Headphone Outputs (HPL, HPR)</b>						

Table 117. Device Characteristics

# TSCS25xx

## Portable Consumer CODECs

Parameter	Symbol	Test Conditions	Min	Typ	Max	Unit
Full Scale Output Level	$V_{FSOV}$	RL = 10Kohm		1.0		Vrms
		$R_L = 16ohm$		0.75		Vrms
Output Power	$P_O$	997Hz full scale signal, $R_L = 16ohm$		35		mW (ave)
Signal to Noise Ratio	SNR	A-weighted, $R_L = 16ohm$		102		dB
Total Harmonic Distortion +Noise	THD+N	$R_L = 16ohms$ , -3dBFS		-76		dB
		$R_L = 32ohms$ , -3dBFS		-78		dB
Analog Voltage Reference Levels						
Charge Pump Output	V-		-5%	-AVDD +100mV	+5%	V
Microphone Bias						
Bias Voltage	$V_{MICBIAS}$		-	2.5	-	V
BIAS current Source					3	mA
Power Supply Rejection Ratio	$PSRR_{MICBIAS}$	3.3V<PVDD<5.25V		80		dB
		3.0V<PVDD<3.3V		40		dB
Digital Input/Output						
ADC/DAC BCLK input rate	Fmax			30		MHz
I2S BCLK/LRCLK ratio			32		1022	clocks/ frame
Input High Level	$V_{IH}$		0.7x DVDD_ IO			V
Input LOW Level	$V_{IL}$				0.3x DVDD_ IO	V
Output High Level	$V_{OH}$	$I_{OH}=-1mA$	0.9x DVDD_IO			V
Output LOW Level	$V_{OL}$	$I_{OL}=1mA$		0.1xDVDD_IO		V
Input Capacitance				5		pF
Input Leakage			-0.9		0.9	uA
Internal Pull-Up Resistor	$R_{PU} / R_{PU}$	All Digital I/O pins with pull-up or pull-down		50		k $\Omega$
ESD / Latchup						
IEC1000-4-2			1			Level
JESD22-A114-B			2			Class
JESD22-C101			4			Class

**Table 117. Device Characteristics**

- 1.Ratio of Full Scale signal to idle channel noise output is measured "A weighted" over a 20 Hz to a 20 kHz bandwidth. (AES17-1991 Idle Channel Noise or EIAJ CP-307 Signal-to-noise Ratio).
- 2.THD+N ratio as defined in AES17 and outlined in AES6id,non-weighted, swept over 20 Hz to 20 kHz bandwidth.

### 8.3. Electrical Characteristics

Unless stated otherwise, DVDD\_Core=1.8V -0.1V/+0.2V, Ambient Temp -10C to +80C

Parameter	Symbol	Test Conditions	Min	Typ	Max	Unit
Operating Voltage	DVDD_CORE		1.7	1.8	2.0	V
Supply Current	I <sub>DVDD_CORE(PLL)</sub>	No Load, VDD=1.9V		11	15	mA
Input High Level	V <sub>IH</sub>		0.7x DVDD_CORE			V
Input LOW Level	V <sub>IL</sub>				0.3xDVDD_CORE	V
Input Capacitance	C <sub>IN</sub>			5		pF
Load Capacitance, X1 and X2	C <sub>L</sub>			5		pF
Output High Level	V <sub>OH</sub>	I <sub>OH</sub> =-2mA	0.8x DVDD_CORE			V
Output LOW Level	V <sub>OL</sub>	I <sub>OL</sub> =2mA			0.2xDVDD_CORE	V
Power Up Time	t <sub>PU</sub>	From minimum VDD to outputs stable		1.5	4	ms
Output Enable Time					20	ns
Output Disable Time					20	ns

Table 118. PLL Section DC Characteristics

**8.3.1. Low Power Mode Consumption**

Mode	AVDD (V)	PVDD (V)	DVDD_CORE (V) DVDD_IO	I AVDD (mA)	IPVDD (mA)	IDVDD_IO IDVDD_CORE (mA)	PTOTAL (mW)
Out of Reset	1.7	5	1.7	0.0064	0	0.18	0.31688
HP Full Power 10k Ω Note 1	1.7	5	1.7	8.7	0	9.9	31.62
HP Low Power 10k Ω Note 2	1.7	5	1.7	3.47	0	4.64	13.787
HP Low Power silence Note 1	1.7	5	1.7	1.87	0	3.45	9.044
<b>Note 1 - DAC is 48kHz with BCLK at 1.536MHz with -3dB signal input</b>							
<b>Note 2 - ADC is 48kHz with BCLK at 1.536MHz with -9dB signal input</b>							
Line In Full Power Note 2	1.7	5	1.7	7.27	0	7.45	25.024
Line In Low Power Note 2	1.7	5	1.7	3	0	2.72	9.724
Line In Low Power Silence Note 2	1.7	5	1.7	2.9	0	0.49	5.763

Table 119. Low Power Mode Consumption



# TSCS25xx

## Portable Consumer CODECs

### 9. REGISTER MAP

Register (D15:9)	Name	Remarks	Bit[7]	Bit[6]	Bit[5]	Bit[4]	Bit[3]	Bit[2]	Bit[1]	Bit[0]	Default
R0 (00h)	HPVOLL	Left HP volume	HPVOL_L[6:0]								79h
R1 (01h)	HPVOLR	Right HP volume	HPVOL_R[6:0]								79h
R2 (02h)	SPKVOLL	SPKR Left volume	SPKVOL_L[6:0]								6Fh
R3 (03h)	SPKVOLR	SPKR Right volume	SPKVOL_R[6:0]								6Fh
R4 (04h)	DACVOLL	Left DAC volume	DACVOL_L[7:0]								FFh
R5 (05h)	DACVOLR	Right DAC volume	DACVOL_R[7:0]								FFh
R6 (06h)	ADCVOLL	Left ADC volume	ADCVOL_L[7:0]								BFh
R7 (07h)	ADCVOLR	Right ADC volume	ADCVOL_R[7:0]								BFh
R8 (08h)	INVOLL	Left Input volume	INMUTE L	IZCL	INVOL_L						17h
R9 (09h)	INVOLR	Right Input volume		IZCR	INVOL_R						17h
R10 (0Ah)	VUCTL	Volume Update Control	ADCFade	DACFad e		INVOLU	ADCVOL U	DACVOLU	SPKVOL U	HPVOLU	C0h
R11 (0Bh)	INMODE	ADC input mode								DS	00h
R12 (0Ch)	INSELL	ADCL signal path	INSEL_L[1:0]		MICBST_L[1:0]						00h
R13 (0Dh)	INSELR	ADCR signal path	INSEL_R[1:0]		MICBST_R[1:0]						00h
R14 (0Eh)	ALC0	ALC0						ALC MODE	ALCSEL[1:0]		00h
R15 (0Fh)	ALC1	ALC1	MAXGAIN[2:0]				ALCL[3:0]				7Bh
R16 (10h)	ALC2	ALC2	MINGAIN[2:0]				HLD[3:0]				00h
R17 (11h)	ALC3	ALC3	DCY[3:0]				ATK[3:0]				32h
R18 (12h)	NGATE	Noise Gate	NGTH[4:0]					NGG[1:0]		NGAT	00h
R19 (13h)	AIC1	Audio Interface 1		BCLKIN V	MS	LRP	WL[1:0]		FORMAT[1:0]		0Ah
R20 (14h)	AIC2	Audio Interface 2	DACDSEL[1:0]		ADCDCSEL[1:0]		TRI	BLRCM[2:0]			00h
R21 (15h)	AIC3	Audio Interface 3			ADOPD D	ALRPDD	ABCPDD	DDIPDD	DLRPDD	DBCPD D	00h
R22 (16h)	CNVTR0	ADC Control	ADCPOL R	ADCPOLL	AMONOMIX[1:0]		ADCMU	HPOR	ADCHPDR	ADCHP DL	08h
R23 (17h)	ADCSR	ADC Sample rate	ABCM[1:0]				ABR[1:0]		ABM[2:0]		12h
R24 (18h)	CNVTR1	DAC Control	DACPOL R	DACPOL L	DMONOMIX[1:0]		DACMU	DEEMP	DACDIT H1	DACDIT H0	08h

# TSCS25xx

## Portable Consumer CODECs

Register (D15:9)	Name	Remarks	Bit[7]	Bit[6]	Bit[5]	Bit[4]	Bit[3]	Bit[2]	Bit[1]	Bit[0]	Default
R25 (19h)	DACSR	DAC Sample rate	DBC[M[1:0]			DBR[1:0]		DBM[2:0]			12h
R26 (1Ah)	PWRM1	Pwr Mgmt (1)	BSTL	BSTR	PGAL	PGAR	ADCL	ADCR	MICB	DIGENB	00h
R27 (1Bh)	PWRM2	Pwr Mgmt (2)	D2S	HPL	HPR	SPKL	SPKR			VREF	00h
R28 (1Ch)	CTL	Additional control	HPSWEN	HPSWOL	EQ2SW1	EQ2SW0	EQ1SW1	EQ1SW0	TSDEN	TOEN	00h
R29 (1Dh)	THERMSTS	Temp Sensor Control	TripHighStat	TripLowStat	TripSplit[1:0]		TripShift[1:0]		Poll[1:0]		09h
R30 (1Eh)	THERMSPKR1	Speaker Thermal Algorithm Control	ForcePwrd	InstCutMode	IncRatio[1:0]		IncStep[1:0]		DecStep[1:0]		81h
R31 (1Fh)	CONFIG0	CONFIG0	ASDM1	ASDM0	DSDM1	DSDM0			dc_bypass	sd_force_on	A0h
R32 (20h)	CONFIG1	CONFIG1	EQ2_EN	EQ2_BE2	EQ2_BE1	EQ2_BE0	EQ1_EN	EQ1_BE2	EQ1_BE1	EQ1_BE0	00h
R33 (21h)	GAINCTL	Gain Control	zerodet_flag		zerodetle_n1	zerodetle_n0	auto_pwr	auto_mute			24h
R34 (22h)	COP1	Constant Output Power1	COPAtten	COPGain	HDeltaEn	COPTarget[4:0]					08h
R35 (23h)	COP2	Constant Output Power2			AvgLength[2:0]				MonRate[2:0]		04h
R36 (24h)	Reserved	Reserved									00h
R37 (25h)	CLECTL	CMPLMTCTL				Lvl_Mode	WindowSel	Exp_En	Limit_En	Comp_En	00h
R38 (26h)	MUGAIN	CLEMakeUpGain				CLEMUG4	CLEMUG3	CLEMUG2	CLEMUG1	CLEMUG0	00h
R39 (27h)	COMPTH	Compressor Threshold	COMPTH7	COMPTH6	COMPTH5	COMPTH4	COMPTH3	COMPTH2	COMPTH1	COMPTH0	00h
R40 (28h)	CMPRAT	Compressor Ratio				CMPRAT4	CMPRAT3	CMPRAT2	CMPRAT1	CMPRAT0	00h
R41 (29h)	CATKTCL	Comp Attack time const Low	CATKTC7	CATKTC6	CATKTC5	CATKTC4	CATKTC3	CATKTC2	CATKTC1	CATKTC0	00h
R42(2Ah)	CATKTCH	Comp Attack time const High	CATKTC15	CATKTC14	CATKTC13	CATKTC12	CATKTC11	CATKTC10	CATKTC9	CATKTC8	00h
R43 (2Bh)	CRELTCL	Comp release time const Low	CRELTC7	CRELTC6	CRELTC5	CRELTC4	CRELTC3	CRELTC2	CRELTC1	CRELTC0	00h
R44 (2Ch)	CRELTCH	Comp release time const High	CRELTC15	CRELTC14	CRELTC13	CRELTC12	CRELTC11	CRELTC10	CRELTC9	CRELTC8	00h
R45 (2Dh)	LIMTH	Limiter Threshold	LIMTH7	LIMTH6	LIMTH5	LIMTH4	LIMTH3	LIMTH2	LIMTH1	LIMTH0	00h
R46 (2Eh)	LIMTGT	Limiter Target	LIMTGT7	LIMTGT6	LIMTGT5	LIMTGT4	LIMTGT3	LIMTGT2	LIMTGT1	LIMTGT0	00h
R47 (2Fh)	LATKTCL	Limiter Attack time constant Low	LATKTC7	LATKTC6	LATKTC5	LATKTC4	LATKTC3	LATKTC2	LATKTC1	LATKTC0	00h

# TSCS25xx

## Portable Consumer CODECs

Register (D15:9)	Name	Remarks	Bit[7]	Bit[6]	Bit[5]	Bit[4]	Bit[3]	Bit[2]	Bit[1]	Bit[0]	Default
R48 (30h)	LATKTCH	Limiter Attack time constant High	LATKTC15	LATKTC14	LATKTC13	LATKTC12	LATKTC1	LATKTC10	LATKTC9	LATKTC8	00h
R49 (31h)	LRELTCL	Limiter Release time constant Low	LRELTC7	LRELTC6	LRELTC5	LRELTC4	LRELTC3	LRELTC2	LRELTC1	LRELTC0	00h
R50 (32h)	LRELTCH	Limiter Release time constant High	LRELTC15	LRELTC14	LRELTC13	LRELTC12	LRELTC1	LRELTC10	LRELTC9	LRELTC8	00h
R51 (33h)	EXPTH	Expander Threshold	EXPTH7	EXPTH6	EXPTH5	EXPTH4	EXPTH3	EXPTH2	EXPTH1	EXPTH0	00h
R52 (34h)	EXPRAT	Expander Ratio						EXPRAT2	EXPRAT1	EXPRAT0	00h
R53 (35h)	XATKTCL	Expander Attack time constant Low	XATKTC7	XATKTC6	XATKTC5	XATKTC4	XATKTC3	XATKTC2	XATKTC1	XATKTC0	00h
R54 (36h)	XATKTCH	Expander Attack time constant High	XATKTC15	XATKTC14	XATKTC13	XATKTC12	XATKTC1	XATKTC10	XATKTC9	XATKTC8	00h
R55 (37h)	XRELTCL	Expander Release time constant Low	XRELTC7	XRELTC6	XRELTC5	XRELTC4	XRELTC3	XRELTC2	XRELTC1	XRELTC0	00h
R56 (38h)	XRELTCH	Expander Release time constant High	XRELTC15	XRELTC14	XRELTC13	XRELTC12	XRELTC1	XRELTC10	XRELTC9	XRELTC8	00h
R57 (39h)	FXCTL	Effects Control				3DEN	TEEN	TNLFBYP	BEEN	BNLFBYP	00h
R58 (3Ah)	DACCRWRL	DACCRAM_WRITE_LO	DACCRWD[7:0]								00h
R59 (3Bh)	DACCRWRM	DACCRAM_WRITE_MID	DACCRWD[15:8]								00h
R60 (3Ch)	DACCRWRH	DACCRAM_WRITE_HI	DACCRWD[23:16]								00h
R61 (3Dh)	DACCRRDLO	DACCRAM_READ_LO	DACCRRD[7:0]								00h
R62 (3Eh)	DACCRRDMD	DACCRAM_READ_MID	DACCRRD[15:8]								00h
R63 (3Fh)	DACCRRDH	DACCRAM_READ_HI	DACCRRD[23:16]								00h
R64 (40h)	DACCRADDR	DACCRAM_ADDR	DACCRADD[7:0]								01h
R65 (41h)	DCOFSEL	DC_COEF_SEL	dc_coef_sel[2:0]								05h
R66 (42h)	PWM0	PWM Control 0	SCTO1	SCTO0	UVLO		bclr	PWMMODE	I	NOOFFSET	C4h
R67 (43h)	PWM1	PWM Control 1	-	dithpos4	dithpos3	dithpos2	dithpos1	dithpos0	dith_range	dithclr	12h
R68 (44h)	PWM2	PWM Control 2									00h
R69 (45h)	PWM3	PWM Control 3	outctrl1	outctrl0				cvalue2	cvalue1	cvalue0	03h
R78 (4Eh)	PLLCTL9	PLL Control 9	refdiv_pll1[7:0]								05h

# TSCS25xx

## Portable Consumer CODECs

Register (D15:9)	Name	Remarks	Bit[7]	Bit[6]	Bit[5]	Bit[4]	Bit[3]	Bit[2]	Bit[1]	Bit[0]	Default
R79 (4Fh)	PLLCTLA	PLL Control 10	outdiv_pll1[7:0]								03h
R80 (50h)	PLLCTLB	PLL Control 11	fbdivl_pll1[7:0]								72h
R81 (51h)	PLLCTLC	PLL Control 12						fbdivH_pll1[10:8]			03h
R82 (52h)	PLLCTLD	PLL Control 13				rz_pll1[1:0]		cp_pll1[2:0]			22h
R83 (53h)	PLLCTLE	PLL Control 14	refdiv_pll2[7:0]								12h
R84 (54h)	PLLCTLF	PLL Control 15	outdiv_pll2[7:0]								03h
R85 (55h)	PLLCTL10	PLL Control 16	fbdivl_pll2[7:0]								1Ch
R86 (56h)	PLLCTL11	PLL Control 17						fbdivh_pll2[10:8]			02h
R87 (57h)	PLLCTL12	PLL Control 18				rz_pll2[1:0]		cp_pll2[2:0]			1Ah
R96 (60h)	PLLCTL1B	PLL Control 27	vcoi_pll2			vcoi_pll1					14h
R97 (61h)	PLLCTL1C	PLL Control 28						pdb_pll2	pdb_pll1		0Fh
R119(77h)	TIMEBASE	Divider	TIMEBASE[7:0]								61h
R124(7Ch)	DEVADR	I2C Device Address	ADDR[7:1]								D2h
R125(7Dh)	DEVIDL	Device IDLow	DID7	DID6	DID5	DID4	DID3	DID2	DID1	DID0	01h
R126(7Eh)	DEVIDH	Device ID High	DID15	DID14	DID13	DID12	DID11	DID10	DID9	DID8	00h
R127(7Fh)	REVID	Device Revision	MAJ3	MAJ2	MAJ1	MAJ0	MNR3	MNR2	MNR1	MNR0	11h
R128(80h)	RESET	Reset	Writing 0x85 to this register resets all registers to their default state								00h
R136(88h)	THERMSPKR2	Speaker Thermal Algorithm Status	ForcePw d Status	VolStatus[6:0]							08h
R137(89h)	COP3	Constant Output Power Status	HighDelta	UNDER VOLTAGE	COPAdj[5:0]						00h
R138(8Ah)	DACCRSTAT	DACCRAM_STATUS	DACCR_Busy								00h
R139(8Bh)	HPDETSTAT	HP detect pin status	HP_Detect								00h
R142(8Eh)	PLLCTL0	PLL Control 0							PLL2LK	PLL1LKk	00h

# TSCS25xx

## Portable Consumer CODECs

Register (D15:9)	Name	Remarks	Bit[7]	Bit[6]	Bit[5]	Bit[4]	Bit[3]	Bit[2]	Bit[1]	Bit[0]	Default	
R143(8Fh)	PLLREFSEL	PLL Control	PLL2_REF			PLL1_REF			00h			
R192(C0h)	GPIOCTL1	GPIO CONTROL	GPIO1CFG		GPIO0CFG		GPIO1DIR		GPIO0DIR		00h	
R193(C1h)	GPIOCTL2	GPIO CONTROL					GPIO1PU		GPIO0PU		00h	
R195(C3h)	ADCPMCTL1	ADC PCM CONTROL1	GAINCODE			GAINENAB	BDELAYO	PCMFL	SLSYNC	00h		
R196(C4h)	ADCPMCTL2	ADC PCM CONTROL2	PCMMOMP	PCMSOP	PCMDSSP			00h				
R197(C5h)	DACPCMCTL1	DAC PCM CONTROL1					BDELAYI	PCMFL	SLSYNC	00h		
R198(C6h)	DACPCMCTL2	DAC PCM CONTROL2	PCMFORMAT	PCMMIM	PCMSI	PCMDSS		PCMSIGNEXT	PCM13MODE	00h		
R199(C7h)	DACMBCEN	Multi-Band SELECTOR						MBCEN3	MBCEN2	MBCEN1	00h	
R200(C8h)	DACMBCCTL	Multi-Band SELECTOR			LVLMODE3	WINSEL3	LVLMODE2	WINSEL2	LVLMODE1	WINSEL1	00h	
R201(C9h)	DACMBCMUG1	Multi-Band SELECTOR			PHASE	MUGAIN					00h	
R202(CA h)	DACMBCTHR1	COMPRESSOR	THRESH									00h
R203(CB h)	DACMBCRAT1	COMPRESSOR	RATIO									00h
R204(CC h)	DACMBCATK1L	COMPRESSOR	TCATKL									00h
R205(CD h)	DACMBCATK1H	COMPRESSOR	TCATKH									00h
R206(CE h)	DACMBCREL1L	COMPRESSOR	TCRELL									00h
R207(CF h)	DACMBCREL1H	COMPRESSOR	TCRELH									00h
R208(D0 h)	DACMBCMUG2	Multi-Band 2SELECTOR			PHASE	MUGAIN					00h	
R209(D1 h)	DACMBCTHR2	COMPRESSOR 2	THRESH									00h
R210(D2 h)	DACMBCRAT2	COMPRESSOR 2	RATIO									00h
R211(D3 h)	DACMBCATK2L	COMPRESSOR 2	TCATKL									00h
R212(D4 h)	DACMBCATK2H	COMPRESSOR 2	TCATKH									00h
R213(D5 h)	DACMBCREL2L	COMPRESSOR 2	TCRELL									00h
R214(D6 h)	DACMBCREL2H	COMPRESSOR 2	TCRELH									00h

# TSCS25xx

## Portable Consumer CODECs

Register (D15:9)	Name	Remarks	Bit[7]	Bit[6]	Bit[5]	Bit[4]	Bit[3]	Bit[2]	Bit[1]	Bit[0]	Default
R215(D7h)	DACMBCMUG3	Multi-Band 3 SELECTOR			PHASE			MUGAIN			00h
R216(D8h)	DACMBCTHR3	COMPRESSOR 3	THRESH								00h
R217(D9h)	DACMBCRAT3	COMPRESSOR 3					RATIO				00h
R218(DAh)	DACMBCATK3L	COMPRESSOR 3	TCATKL								00h
R219(DBh)	DACMBCATK3H	COMPRESSOR 3	TCATKH								00h
R220(DCh)	DACMBCREL3L	COMPRESSOR 3	TCRELL								00h
R221(DDh)	DACMBCREL3H	COMPRESSOR 3	TCRELH								00h

**Table 120. Register Map**

*Note:*

- Registers not described in this map should be considered “reserved”.
- Numerous portions of the register map are compatible with popular codecs from other vendors.

10. PIN INFORMATION

10.1. TSCS25A3 Pin Diagram

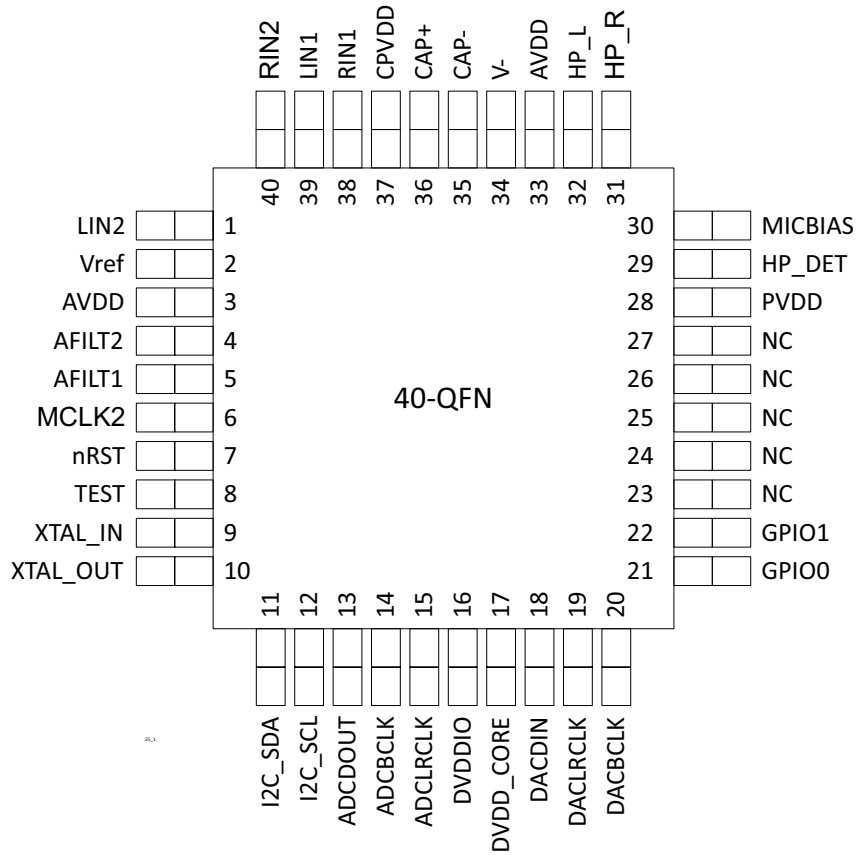

Figure 32. 40QFN Pin Assignment

## 10.2. Pin Tables

### 10.2.1. Power Pins

Pin Name	Pin Function	I/O	Internal Pull-up Pull-down	40 pin loc
PVDD	Bias supply	I(Power)	None	28
DVDD_Core	DSP and other core logic+clocks	I(Power)	None	17
DVDDIO	Interface (I <sup>2</sup> S, I <sup>2</sup> C, GPIO)	I(Power)	None	16
AVDD	Analog core supply	I(Power)	None	3,33
CPVDD	Charge pump supply	I(Power)	None	37
CAP+	Flying cap	I/O(Power)	None	36
CAP-	Flying cap	I/O(Power)	None	35
V-	Negative Analog supply (Bypass cap)	O(Power)	None	34
VSS	DAP		None	

Table 121. Power Pins

Total Pins: 9

### 10.2.2. Reference Pins

Pin Name	Pin Function	I/O	Internal Pull-up Pull-down	40 Pin loc
MICBIAS	2.5V 1.5 mA microphone bias	O(Analog)	None	30
AFILT1	ADC input filter cap	I(Analog)	None	5
AFILT2	ADC input filter cap	I(Analog)	None	4
Vref	VREF reference pin (bypass)	I(Analog)	None	2

Table 122. Reference Pins

Total Pins: 4

### 10.2.3. Analog Input Pins

Pin Name	Pin Function	I/O	Internal Pull-up Pull-down	40 Pin loc
LIN1	Left Input #1	I(Analog)	None	39
RIN1	Right Input #1	I(Analog)	None	38
LIN2	Left Input #2	I(Analog)	None	1
RIN2	Right Input #2	I(Analog)	None	40

Table 123. Analog Input Pins

Total Pins: 4



**10.2.4. Analog Output Pins**

Pin Name	Pin Function	I/O	Internal Pull-up Pull-down	40 Pin loc
HP_L	Headphone output	O(Analog)	None	32
HP_R	Headphone output	O(Analog)	None	31

**Table 124. Analog Output Pins**

Total Pins: 2

**10.2.5. Data and Control Pins**

Pin Name	Pin Function	I/O	Internal Pull-up Pull-down	40 Pin loc
GPIO1	General purpose I/O	I/O	none	22
GPIO0	General purpose I/O	I/O	none	21
nRST	Reset	I(Digital)	none	7
ADCBCLK	ADC I <sup>2</sup> S shift clock	I/O(Digital)	Pull-Down	14
ADCLRCLK	ADC I <sup>2</sup> S framing clock	I/O(Digital)	Pull-Down	15
ADCDOUT	ADC I <sup>2</sup> S output data	O(Digital)	Pull-Down	13
DACBCLK	DAC I <sup>2</sup> S shift clock	I/O(Digital)	Pull-Down	20
DACLRCLK	DAC I <sup>2</sup> S framing clock	I/O(Digital)	Pull-Down	19
DACDIN	DAC I <sup>2</sup> S input data	I(Digital)	Pull-Down	18
I2C_SCL	SCL I <sup>2</sup> C shift clock	I(Digital)	Pull-Up	12
I2C_SDA	SDA I <sup>2</sup> C shift data	I(Digital)	Pull-Up	11
HP_DET	Headphone jack detection	I(Digital)	Pull-Up	29
P_8	Reserved test pin	I(Analog)	None	8

**Table 125. Data and Control Pins**

Total Pins: 13

**10.2.6. PLL Pins**

Pin Name	Pin Function	I/O	Internal Pull-up Pull-down	40 Pin loc
MCLK2	MASTER CLK	I(CLK)	NONE	6

**Table 126. PLL Pins**

Total Pins: 1

**10.2.7. No Connetion Pins**

Pin Name	40 Pin loc
NC	9,10,23,24,25,26,27

**Table 127. PLL Pins**

Total Pins: 7

11. PACKAGE DRAWINGS

11.1. 40QFN Package Outline and Package Dimensions

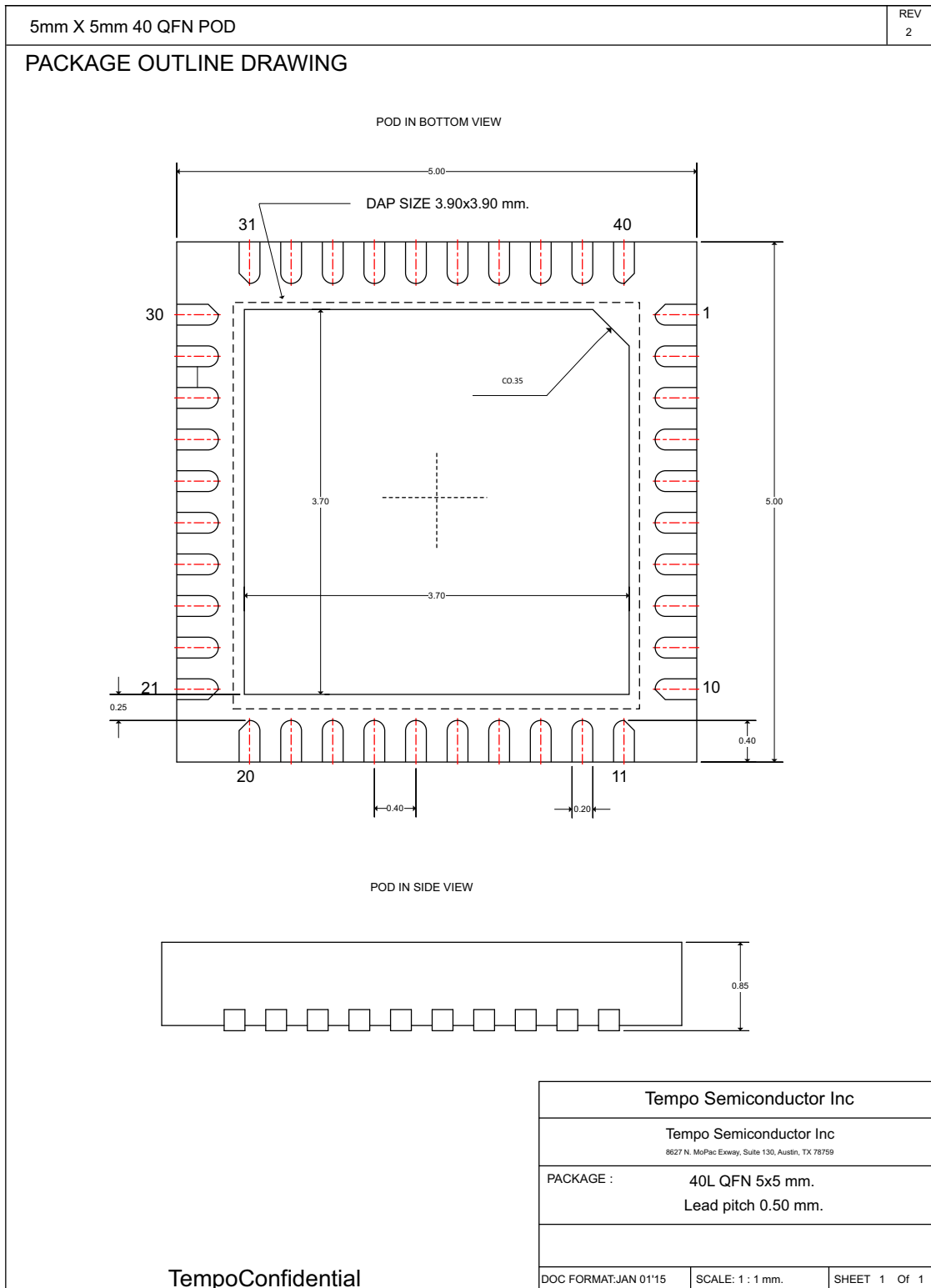

Figure 33. 40QFN Package Diagram

## 11.2. Pb Free Process- Package Classification Reflow Temperatures

Package Thickness	Volume mm <sup>3</sup> <350	Volume mm <sup>3</sup> 350 - 2000	Volume mm <sup>3</sup> >2000
<1.6mm	260 + 0 °C*	260 + 0 °C*	260 + 0 °C*
1.6mm - 2.5mm	260 + 0 °C*	250 + 0 °C*	245 + 0 °C*
> or = 2.5mm	250 + 0 °C*	245 + 0 °C*	245 + 0 °C*

\*Tolerance: The device manufacturer/supplier shall assure process compatibility up to and including the stated classification temperature (this means Peak reflow temperature +0 °C. For example 260 °C+0 °C) at the rated MSL level.

**Table 128. Reflow Temperatures**

Note: TSI's package thicknesses are <2.5mm and <350 mm<sup>3</sup>, so 260 applies in every case.

## **12. APPLICATION INFORMATION**

For application information, please see reference designs and application notes available on [www.temposemi.com](http://www.temposemi.com).

## TSCS25xx

### Portable Consumer CODECs

---

## 13. ORDERING INFORMATION

TSCS25A3X1NDGXyyX	Analog Microphone in 40 QFN package
-------------------	-------------------------------------

Please contact an TSI Sales Representative with your clock requirements for factory programming. This programming will determine the orderable part number for the TSCS25xx.

## **14. DISCLAIMER**

While the information presented herein has been checked for both accuracy and reliability, manufacturer assumes no responsibility for either its use or for the infringement of any patents or other rights of third parties, which would result from its use. No other circuits, patents, or licenses are implied. This product is intended for use in normal commercial applications. Any other applications, such as those requiring extended temperature range, high reliability, or other extraordinary environmental requirements, are not recommended without additional processing by manufacturer. Manufacturer reserves the right to change any circuitry or specifications without notice. Manufacturer does not authorize or warrant any product for use in life support devices or critical medical instruments

---

## 15. DOCUMENT REVISION HISTORY

Revision	Date	Description of Change
0.5	Feb 2016	Initial release
0.6	Feb 2016	Updated table and PLL's
0.7	Nov 2016	Updated diagrams
0.8	Jan 2017	removed confidential and preliminary
0.9	Jan 2017	corrected SNR information
1.0	April 2017	Corrected Treble and Bass Diagram and Output Power corrections
1.1	April 2017	Format changed



<https://www.temposemi.com>

8627 N. MoPac Expwy, Suite 130

Austin, Texas 78759

DISCLAIMER Tempo Semiconductor, Inc. (TSI) and its subsidiaries reserve the right to modify the products and/or specifications described herein at any time and at TSI's sole discretion. All information in this document, including descriptions of product features and performance, is subject to change without notice. Performance specifications and the operating parameters of the described products are determined in the independent state and are not guaranteed to perform the same way when installed in customer products. The information contained herein is provided without representation or warranty of any kind, whether express or implied, including, but not limited to, the suitability of TSI's products for any particular purpose, an implied warranty of merchantability, or non-infringement of the intellectual property rights of others. This document is presented only as a guide and does not convey any license under intellectual property rights of TSI or any third parties.

TSI's products are not intended for use in life support systems or similar devices where the failure or malfunction of an TSI product can be reasonably expected to significantly affect the health or safety of users. Anyone using an TSI product in such a manner does so at their own risk, absent an express, written agreement by TSI.

Tempo Semiconductor, TSI and the TSI logo are registered trademarks of TSI. Bluetooth is a registered trademark of Bluetooth SIG. Other trademarks and service marks used herein, including protected names, logos and designs, are the property of TSI or their respective third party owners.



## Стандарт Электрон Связь

Мы молодая и активно развивающаяся компания в области поставок электронных компонентов. Мы поставляем электронные компоненты отечественного и импортного производства напрямую от производителей и с крупнейших складов мира.

Благодаря сотрудничеству с мировыми поставщиками мы осуществляем комплексные и плановые поставки широчайшего спектра электронных компонентов.

Собственная эффективная логистика и склад в обеспечивает надежную поставку продукции в точно указанные сроки по всей России.

Мы осуществляем техническую поддержку нашим клиентам и предпродажную проверку качества продукции. На все поставляемые продукты мы предоставляем гарантию .

Осуществляем поставки продукции под контролем ВП МО РФ на предприятия военно-промышленного комплекса России , а также работаем в рамках 275 ФЗ с открытием отдельных счетов в уполномоченном банке. Система менеджмента качества компании соответствует требованиям ГОСТ ISO 9001.

Минимальные сроки поставки, гибкие цены, неограниченный ассортимент и индивидуальный подход к клиентам являются основой для выстраивания долгосрочного и эффективного сотрудничества с предприятиями радиоэлектронной промышленности, предприятиями ВПК и научно-исследовательскими институтами России.

С нами вы становитесь еще успешнее!

### Наши контакты:

**Телефон:** +7 812 627 14 35

**Электронная почта:** [sales@st-electron.ru](mailto:sales@st-electron.ru)

**Адрес:** 198099, Санкт-Петербург,  
Промышленная ул, дом № 19, литера Н,  
помещение 100-Н Офис 331