

# iMX RT1052 Developer's Kit User's Guide

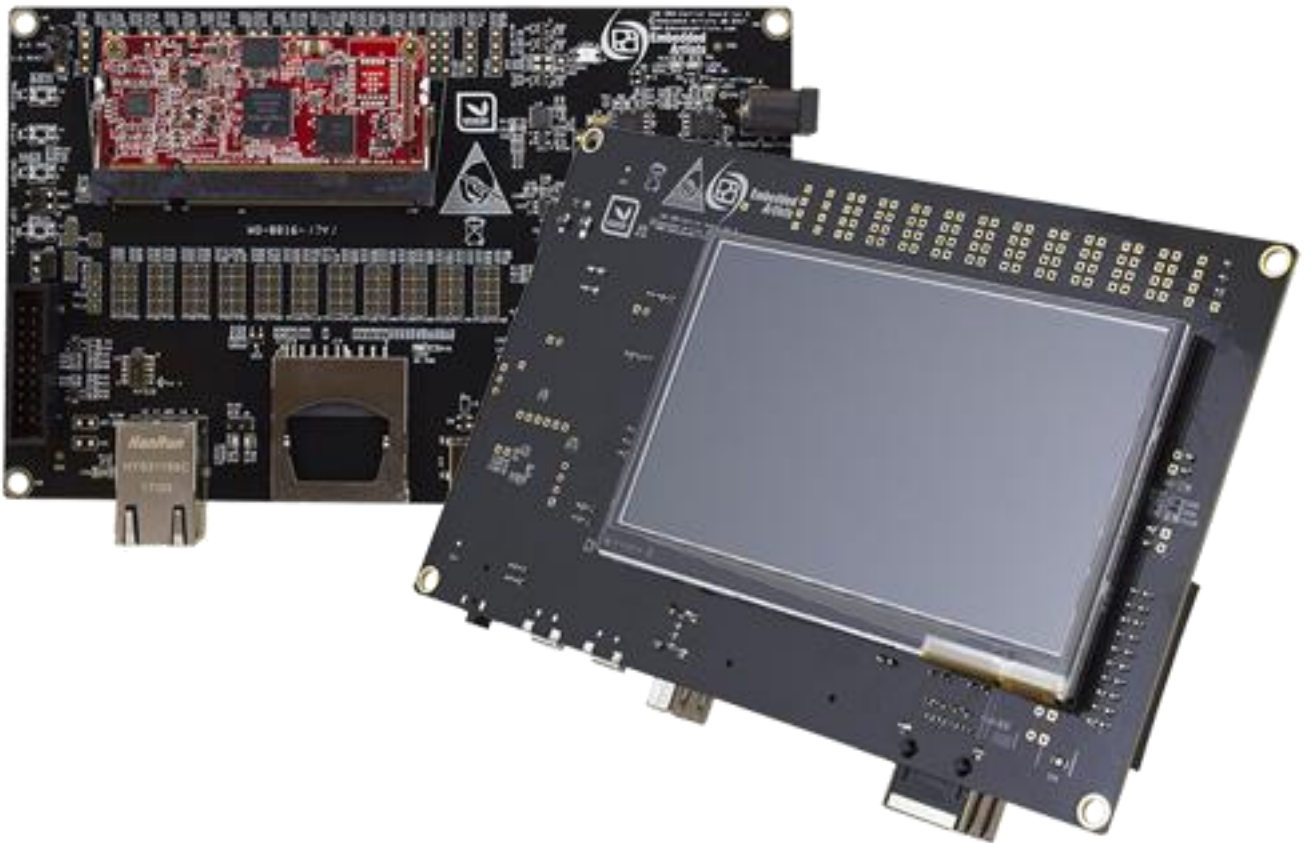

*Get Up-and-Running Quickly and  
Start Developing Your Application On Day 1!*

## Embedded Artists AB

Jörgen Ankersgatan 12  
211 45 Malmö  
Sweden

<http://www.EmbeddedArtists.com>

### **Copyright 2018 © Embedded Artists AB. All rights reserved.**

No part of this publication may be reproduced, transmitted, transcribed, stored in a retrieval system, or translated into any language or computer language, in any form or by any means, electronic, mechanical, magnetic, optical, chemical, manual or otherwise, without the prior written permission of Embedded Artists AB.

### **Disclaimer**

Embedded Artists AB makes no representation or warranties with respect to the contents hereof and specifically disclaim any implied warranties or merchantability or fitness for any particular purpose. Information in this publication is subject to change without notice and does not represent a commitment on the part of Embedded Artists AB.

### **Feedback**

We appreciate any feedback you may have for improvements on this document. Please send your comments to [support@EmbeddedArtists.com](mailto:support@EmbeddedArtists.com).

### **Trademarks**

All brand and product names mentioned herein are trademarks, services marks, registered trademarks, or registered service marks of their respective owners and should be treated as such.

# Table of Contents

<b>1</b>	<b>Document Revision History</b>	<b>5</b>
<b>2</b>	<b>Getting Started</b>	<b>6</b>
2.1	iMX RT1052 Developer's Kit Content	6
2.2	Hardware Overview	6
2.3	Connecting - Get Started	8
2.3.1	Tera Term Terminal Emulation Application	9
2.3.2	PuTTY terminal emulation application	10
2.4	Alternative Powering	11
2.5	ESD Precaution	11
2.6	General Handling Care	12
2.7	Handling SO-DIMM Boards	12
2.8	OTP Fuse Programming	13
2.9	CE Assessment	13
2.10	Further Information	13
<b>3</b>	<b>Demo Application</b>	<b>14</b>
<b>4</b>	<b>iMX OEM Carrier Board Design</b>	<b>15</b>
4.1	Modifications to iMX OEM Carrier Board	15
4.2	SP2a: Power Supplies	16
4.3	SP2b: Current Measurement	18
4.4	SP2c: VBAT Powering	19
4.5	SP3-SP4: OEM Board Connector (SODIMM) and Access Pads	20
4.6	SP5: Push-buttons and LEDs	21
4.7	SP6: Debug Interfaces	23
4.8	SP7: USB Interfaces	25
4.9	SP8: CAN	26
4.10	SP9: SD Memory Card Interface	27
4.11	SP10: LCD Interface	27
4.12	SP11: Ethernet Interface	28
4.13	SP12: UART-to-USB Bridge	29
4.14	SP13: Audio Codec	30
4.15	Default Jumpers Positions	31
4.16	Usage of CPU Pins	32
4.17	Things to Note	35
4.17.1	Errata on i.MX RT1052 silicon rev A0	35
4.17.2	Three signals in SD interface not available at TPx access pads	35
<b>5</b>	<b>Troubleshooting</b>	<b>36</b>
5.1	No SWD/JTAG Connection	36
5.2	Powering	36

5.3	Contact with OEM Board MCU	36
5.4	Using the Demo Application to Verify Correct Operation	36
<b>6</b>	<b>Different Board Versions</b>	<b>37</b>
<b>7</b>	<b>Disclaimers</b>	<b>38</b>
7.1	Definition of Document Status	39

# 1 Document Revision History

<i>Revision</i>	<i>Date</i>	<i>Description</i>
PA2	2017-12-19	First released version.
PA3	2018-01-01	Moved program development information to separate document.
PA4	2018-02-05	Added information about SWO trace.
PA5	2018-02-12	Minor corrections on cross-reference.
PA6	2018-04-17	Updated information on i.MX RT1052 silicon revision A0 and A1.

## 2 Getting Started

This chapter contains information about how to get acquainted with the *iMX RT1052 Developer's Kit*. **Please read this chapter first before you start using the board - it will be well spent time!**

First of all, thank you for buying Embedded Artists' *iMX RT1052 Developer's Kit* based on NXP's ARM Cortex-M7 i.MX RT1052 microcontroller. **You will get up-and-running quickly!**

- Section 2.1 contains a list of what is included in the *iMX RT1052 Developer's Kit*.
- Section 2.2 together with Figure 10 in chapter 4 gives an overview presentation of the hardware and the interfaces and connectors available.
- Section 2.3 describes how to connect the USB cable, install the UART-to-USB driver and powerup the board the first time.
- Section 2.4 presents an alternative powering solution via a 5V DC power jack.
- Section 2.5 - 2.9 describes important handling and care issues.
- Section 2.10 contains information about further reading.
- Chapter 3 describes the demo application that can also be used to verify correct operation of the hardware.
- Chapter 4 presents the hardware design of the *iMX OEM Carrier Board*.
- Chapter 5 contains some troubleshooting information.

To get started with program development and program download/flashing, see document *iMX RT1052 Developer's Kit Program Development Guide*.

### 2.1 iMX RT1052 Developer's Kit Content

- One *iMX RT1052 COM* board mounted on one *iMX COM Carrier board*, see Figure 1 below.
- One micro-B to A USB cable
- A *product serial number* that you should register on Embedded Artists' support page. First create a support account and then register the product serial number to this account. On the support page for the *iMX RT1052 Developer's Kit* you will get access to the schematic of the *iMX OEM Carrier board*, datasheets, etc.

For program development you will additionally need a debug probe, like ULINK, J-LINK or LPC-Link2, and a program development environment, like Keil uVision or MCUXpresso. For more information about program development, see document *iMX RT1052 Developer's Kit Program Development Guide*.

### 2.2 Hardware Overview

Figure 1 below illustrates the top side of the *iMX OEM Carrier board*. Some key components, relevant to get started, have been marked in the picture.

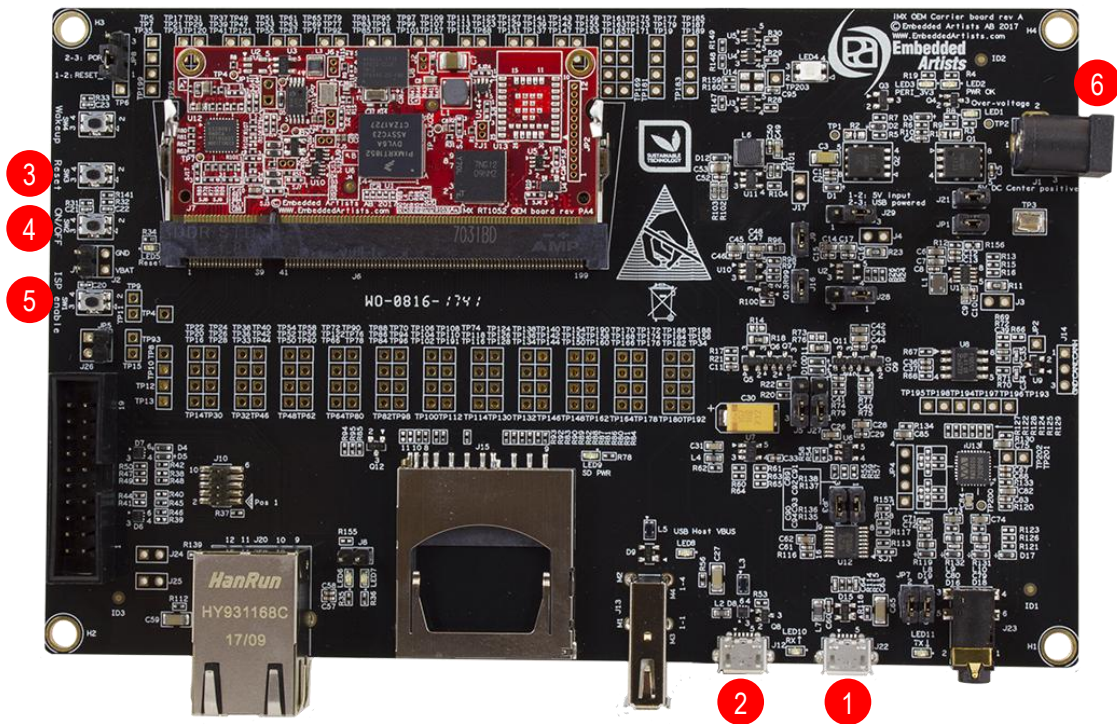

Figure 1 – iMX RT1052 Developer's Kit Top View

1. UART-to-USB bridge - this gives access to the console UART of the i.MX RT1052 MCU. The USB interface can also power the board.
2. USB OTG connector - this USB interface can, together with a PC application, be used to program the flash memory of the *iMX RT1052 OEM board*.
3. Reset push-button - a press will generate a power cycle (in default behavior).
4. ON/OFF push-button - a 5 second press will shut down the main 3.3V supply.
5. ISP Enable push-button - pressing this button while the board power up will place the i.MX RT1052 in ISP mode (typically used for programming the *iMX RT1052 OEM board* flash memory).
6. Alternative power supply input - this is an alternative power supply input, 5V/1A DC, via a 2.1mm power jack. The center position is the positive terminal.

Figure 10 in chapter 4 gives a slightly more detailed presentation of all interfaces and connectors on the board.

Figure 2 below illustrates the bottom side of the iMX OEM Carrier board. A 4.3 inch LCD with capacitive touch panel is mounted there. When developing graphical applications, this side is typically turned up.



Figure 2 – iMX RT1052 Developer's Kit Bottom View

## 2.3 Connecting - Get Started

Begin by connecting the micro-B USB connector to position 1) in Figure 1 above. Connect the other end of the USB cable to the PC. The pre-loaded demo application will immediately start, showing some graphics on the LCD (on the bottom side). The demo application is described in more detail in section 3.

Meanwhile the PC will typically install drivers automatically for the UART-to-USB bridge that creates a Virtual COM port, if they are not already installed. If you have problems the drivers can be downloaded from the links below:

<http://www.ftdichip.com/Drivers/VCP.htm>

<http://www.ftdichip.com/Support/Documents/InstallGuides.htm>

When the driver has been installed, a new COM port will be listed under “Ports” in the Device Manager as shown in Figure 3. Please note that the actual port number will most likely be different on your computer.

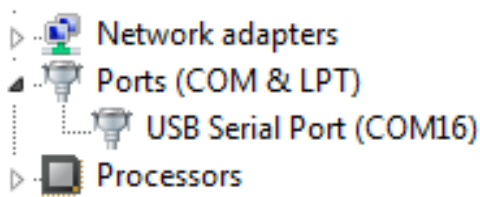

Figure 3 – Virtual COM port shown in device manager



The next step is to open a terminal application and attached it to the Virtual COM port that has just been created. The baud rate should be **115200**.

Some development environments/IDEs have a built-in terminal application that can be used. Sometimes it is better to have a terminal application with more features. For increased flexibility, we recommend using any of the two alternative terminal applications presented in the following sub-sections.

### 2.3.1 Tera Term Terminal Emulation Application

We recommend that you use **Tera Term** which can be downloaded and installed from either of the links below.

<https://tssh2.osdn.jp/index.html.en>  
<http://sourceforge.jp/projects/tssh2/releases/>

Launch *Tera Term*. The first time it launches, it will show you the following dialog. Select the serial option. Assuming the USB cable is connected to the *iMX OEM Carrier Board*, there should be a COM port automatically populated in the list.

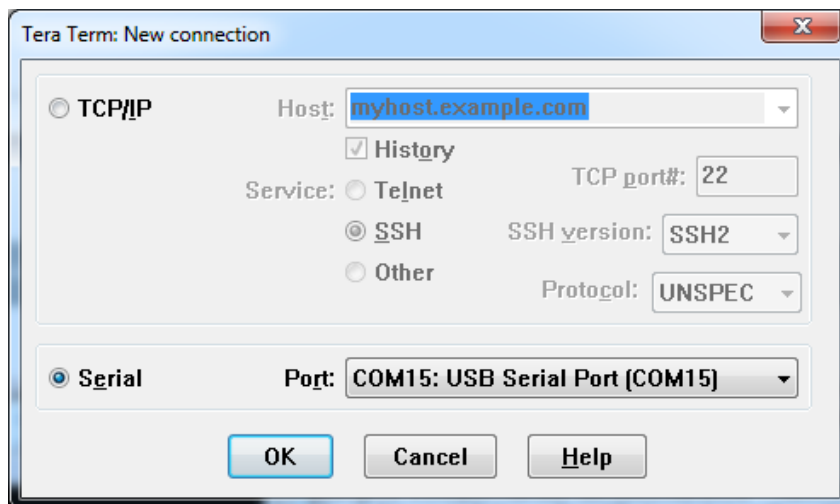

Figure 4 – Tera Term New Connection Window

Configure the serial port settings (using the COM port number identified earlier) to 115200 baud rate, 8 data bits, no parity and 1 stop bit. To do this, go to Setup → Serial Port and change the settings.

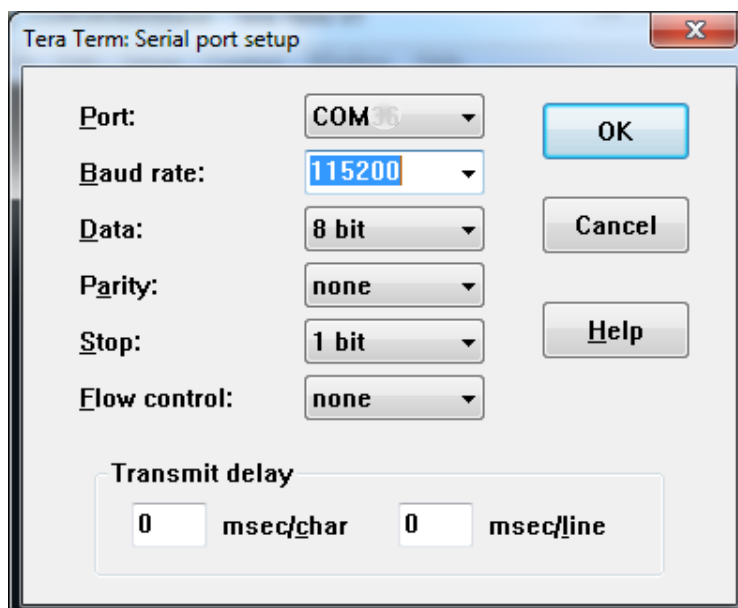

Figure 5 – Tera Term Serial Port Setup

Verify that the connection is open. If connected, *Tera Term* will show something like below in its title bar.

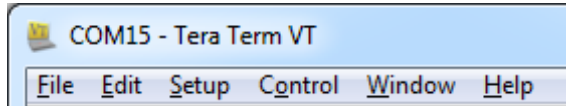

Figure 6 – Tera Term Menu

### 2.3.2 PuTTY terminal emulation application

Alternatively you can use **PuTTY**. It is another commonly used terminal emulation application. PuTTY can be downloaded and installed from the link below.

<http://www.chiark.greenend.org.uk/~sgtatham/putty/download.html>

Launch PuTTY by either double clicking on the \*.exe file you downloaded or from the Start menu, depending on the type of download you selected.

In the window that launches, select the Serial radio button and enter the COM port number that you determined earlier. Also enter the baud rate, in this case 115200.

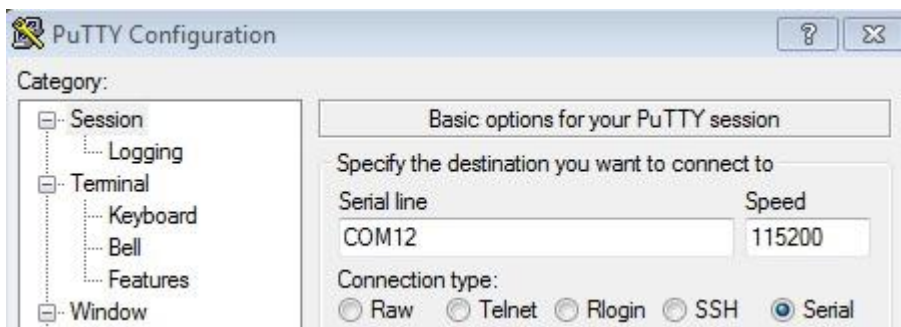

Figure 7 – PuTTY New Session Configuration

Click Open to open the serial connection. Assuming the FTDI cable is connected and you entered the correct COM port, the terminal window will open. If the configuration is not correct, PuTTY will alert you.

## 2.4 Alternative Powering

The board is normally powered from a PC/laptop via the included USB cable (micro-B to A cable) when connected to position 1) in Figure 1 above. This setup will work in most cases. However note that not all PC/laptops can provide the needed current. A powered USB hub can be used in this case or an external power supply.

A separate power supply is always needed in stand-alone situations or when running USB Host application that require powering external USB devices. If USB Host is not used (or used with very low external current consumption), a 5V DC/1 Amp power supply (5W) is all what is needed. If USB Host is used with high external current consumption a 5V DC/2-2.5 Amp power supply (10-12.5W) is needed. A 2.1mm standard power plug is used to interface the board. Center position is the positive terminal.

It is possible to have both the USB cable and external powering connected to the board at the same time but only one of them will be used at any time. Powering selector, J29, selects either +5V DC powering via J1 or USB powering via J22. See Figure 8 below where to locate J29.

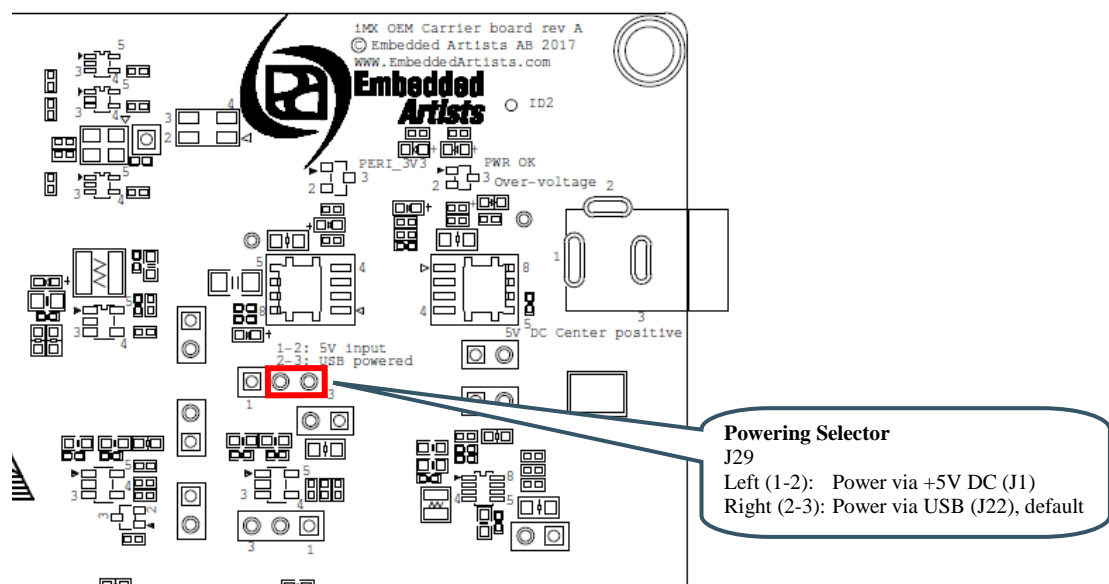

Figure 8 – Location of Powering Selector, J29

## 2.5 ESD Precaution

Please note that the *iMX RT1052 OEM Board* and *iMX OEM Carrier Board* come without any case/box and all components are exposed for finger touches – and therefore extra attention must be paid to ESD (electrostatic discharge) precaution.

***Make it a habit always to first touch the metal surface of one of the USB, SD or Ethernet connectors for a few seconds with both hands before touching any other parts of the boards.*** That way, you will have the same potential as the board and therefore minimize the risk for ESD.

Never touch directly on the *iMX RT1052 OEM Board* and in general as little as possible on the *iMX OEM Carrier Board*. The push-buttons on the *iMX OEM Carrier Board* have grounded shields to minimize the effect of ESD.

**Note that Embedded Artists does not replace boards that have been damaged by ESD.**



## 2.6 General Handling Care

Handle the *iMX RT1052 OEM Board* and *iMX OEM Carrier Board* with care. The boards are not mounted in a protective case/box and are not designed for rough physical handling. Connectors can wear out after excessive use. The *iMX OEM Carrier Board* is designed for prototyping use, and not for integration into an end-product.

For boards with LCD, do not exercise excessive pressure on the LCD glass area. That will damage the display. Also, do not apply pressure on the flex cables connecting the LCD/touch screen. These are relatively sensitive and can be damaged if too much pressure is applied to them.

**Note that Embedded Artists does not replace boards where the LCD has been improperly handled.**

## 2.7 Handling SO-DIMM Boards

See picture below for instructions about how to mount/remove the *OEM Board* in the SODIMM connector of the *iMX OEM Carrier Board*.

To install the *OEM Board*, align it to the socket (1). Push the board gently, and with even force between the board edges, fully into the socket (2). Then push the board down in a rotating move (3) until it snaps into place (4). The *OEM Board* shall lie flat and parallel to the base board.

To remove the *OEM Board*, spread the two arms of the SO-DIMM socket apart slightly. The board will pop up (5). Gently rise the board in a rotating move (6) and then extract the board from the socket (7). Apply even force between board edges when removing so that the board is removed parallel to the locking arms.

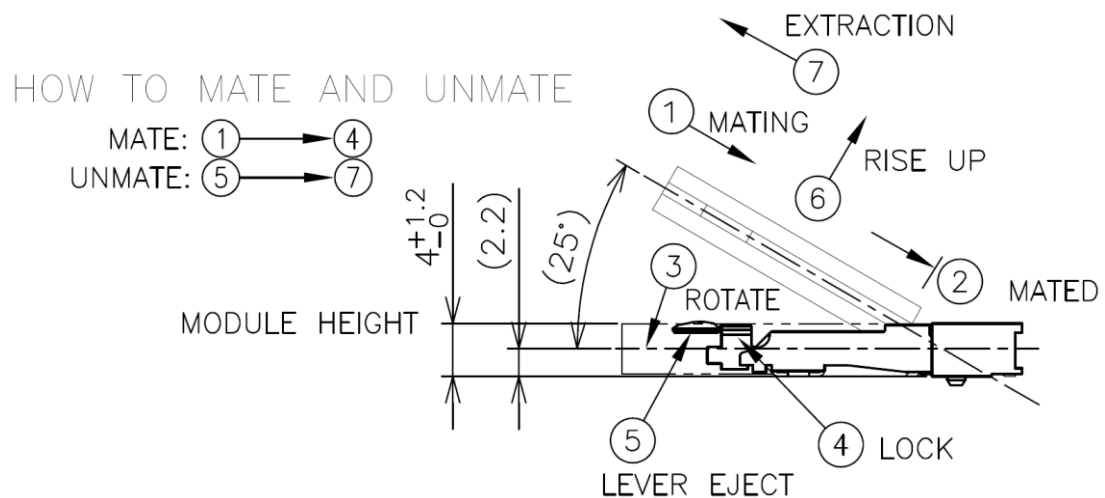

Figure 9 – Instructions how to Mount/Remove the an OEM Board

Do not forget to follow standard ESD precaution routines when mounting/removing the *OEM Board*. Most signals exposed on the 200 edge contact fingers on the SO-DIMM board are unprotected. Maintain the same electrical potential of the *OEM Board* (to be mounted) and the base board. Do not touch the *OEM Board* edge connectors. Handle the *OEM Board* only by the three other edges. Also, do not touch the components on the board.

## 2.8 OTP Fuse Programming

The i.MX RT1052 MCU has on-chip OTP fuses that can be programmed, see NXP documents *IMXRT1050CEC*, *.MX RT1050 Crossover Processors for Consumer Products - Data Sheet* and *IMXRT1050RM*, *i.MX RT1050 Processor Reference Manual* for details. Once programmed, there is no possibility to reprogram them.

*iMX RT1052 OEM Boards* are delivered without any OTP fuse programming. It is completely up to the OEM board user to decide if OTP fuses shall be programmed and in that case, which ones.

**Note that Embedded Artists does not replace iMX RT1052 OEM Boards because of wrong OTP programming. It's the user's responsibility to be absolutely certain before OTP programming and not to program the fuses by accident.**

## 2.9 CE Assessment

The *iMX RT1052 Developers Kit* (consisting of the *iMX RT1052 OEM Board* and *iMX OEM Carrier Board*) is CE marked. See separate *CE Declaration of Conformity* document.

The *iMX RT1052 Developers Kit* is a class A product. In a domestic environment this product may cause radio interference in which case the user may be required to take adequate measures.

EMC emission test has been performed on the *iMX RT1052 Developers Kit*. Standard interfaces like Ethernet, USB, serial have been in use. General expansion connectors where internal signals are made available (for example processor pins) have been left unconnected. Connecting other devices to the product via the general expansion connectors may alter EMC emission. It is the user's responsibility to make sure EMC emission limits are not exceeded when connecting other devices to the general expansion connectors of the *iMX RT1052 Developers Kit*.

Due to the nature of the *iMX RT1052 Developers Kit* – an evaluation board not for integration into an end-product – fast transient immunity tests and conducted radio-frequency immunity tests have not been executed. Externally connected cables are assumed to be less than 3 meters. The general expansion connectors where internal signals are made available do not have any other ESD protection than from the chip themselves. Observe ESD precaution.

Note that the *iMX RT1052 OEM board* is classified as a component and is hence not CE marked separately. It can perform different functions in different integrations and it does not have a direct function. It is therefore not in the scope of the CE Directive. An end product, where an *OEM Board* is integration into, is however very likely to need CE marking.

## 2.10 Further Information

The following NXP documents are important reference documents and should be consulted for functional details:

- *IMXRT1050CEC*, *.MX RT1050 Crossover Processors for Consumer Products - Data Sheet*, latest revision
- *IMXRT1050IEC*, *.MX RT1050 Crossover Processors for Industrial Products - Data Sheet*, latest revision
- *IMXRT1050RM*, *i.MX RT1050 Processor Reference Manual*, latest revision
- *IMXRT1050CE*, *Chip Errata for the i.MX RT1050*, latest revision  
**Note:** It is the user's responsibility to make sure all errata published by the manufacturer are taken note of. The manufacturer's advice should be followed.
- AN12094, *Power consumption and measurement of i.MXRT1050*, latest revision

### 3 Demo Application

The *iMX RT1052 Developer's Kit* comes pre-loaded with a demo application. If the demo application is missing or over-written by another application, follow the guidelines for how to download a program in the document *iMX RT1052 Developer's Kit Program Development Guide*. A pre-compiled binary file is available on the support site. It can be downloaded with the Mfgtool application.

The demo application demonstrates some features of the *iMX RT1052 Developer's Kit* (note that early versions of the Demo application might not support all tests/demos - make sure the latest version is downloaded if the demo application shall be used to verify correct operation of the different interfaces):

- A picture is displayed on the LCD.
- The capacitive touch panel (on the LCD) writes small black dots (one pixel in size) whenever a touch event is detected. Detected coordinates are also printed in the console.
- An audible tone is sent to the headphone interface.
- It is possible to Ping the Ethernet interface. The IP address is hard coded to 192.168.6.231. Received ping requests from a pc are printed on the console. After 5 received pings it stops writing received pings.
- USB Host, via the USB Host connector J13. It is possible to insert a Mass-storage Device (MSC), i.e., USB memory stick, that is detected.
- USB Device, via the USB OTG connector J12. When connected to a Windows PC, the USB interface behaves like a mouse and move the cursor in a square patter.
- It is possible to insert a SD memory card that is detected.
- Presses on WAKE and ISP Enable push buttons are detected
- UART and USB-to-UART bridge; a message is printed on the UART. It will look something like this (date and version number will likely be different):

```
*****
*
* Demo Application for the iMX RT1052 Developer's Kit *
* (C) Embedded Artists AB 2017 *
* *
* *
*   Thank you for buying Embedded Artists' *
*   iMX RT1052 Developer's Kit *
* *
*   ... and congratulations on your choice *
*   of microcontroller! *
* *
*****
Version: 1.0, (build December 12 2017)
```

## 4 iMX OEM Carrier Board Design

This chapter contains information about the peripherals and general design of the *iMX OEM Carrier Board* and how to set the different jumpers on the board. The schematic can be downloaded in pdf format from the support page, and is recommended to have printed out while reading this chapter.

Section naming begins with *SPx*, which is short for *Schematic Page x*.

The picture below gives an overview of the *iMX OEM Carrier Board* design.

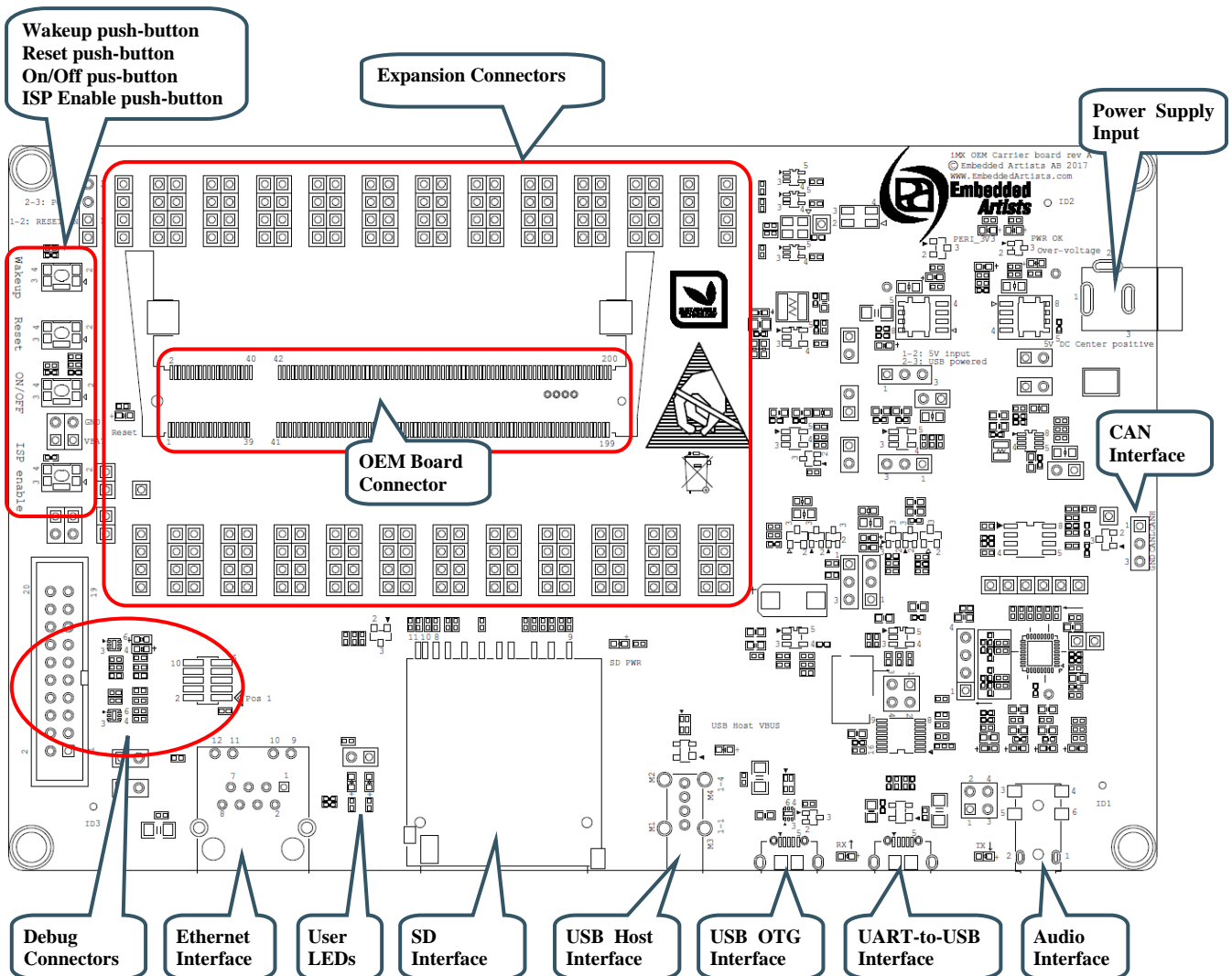

Figure 10 – iMX OEM Carrier Board Overview

### 4.1 Modifications to iMX OEM Carrier Board

The *iMX OEM Carrier Board* has been designed to be flexible. Most options can be controlled via jumpers but some options might need soldering.

**Note that modifications to the board are done at own risk and void all warranties.**

## 4.2 SP2a: Power Supplies

The power supply structure on the *iMX OEM Carrier board* is straight forward. There are two powering sources, selected via J29:

1. +5V DC via power jack (J1). 2.1mm inner diameter, 5.5mm outer diameter, center pin positive. This input has reverse polarity and over-voltage protection.
  - This powering source is always needed in stand-alone situations or when running USB Host application that require powering external USB devices. If USB Host is not used (or used with very low external current consumption), a 5V DC/1 Amp power supply (5W) is all what is needed. If USB Host is used with high external current consumption a 5V DC/2-2.5 Amp power supply (10-12.5W) is needed.
2. USB powering via the UART-to-USB Bridge connector (J22).
  - The board is normally powered from a PC/laptop via the included USB cable (micro-B to A cable) when connected to J22 (position 1) in Figure 1). This setup will work in most cases. However note that not all PC/laptops can provide the needed current. A powered USB hub or an external power supply can be used in this case.

It is possible to have both the USB cable and external powering connected to the board at the same time but only one of them will be used at any time. Powering selector, J29, selects either of the two powering sources. See Figure 12 below where to locate J29.

The picture below is principal schematic of the powering structure of the *iMX OEM Carrier board*.

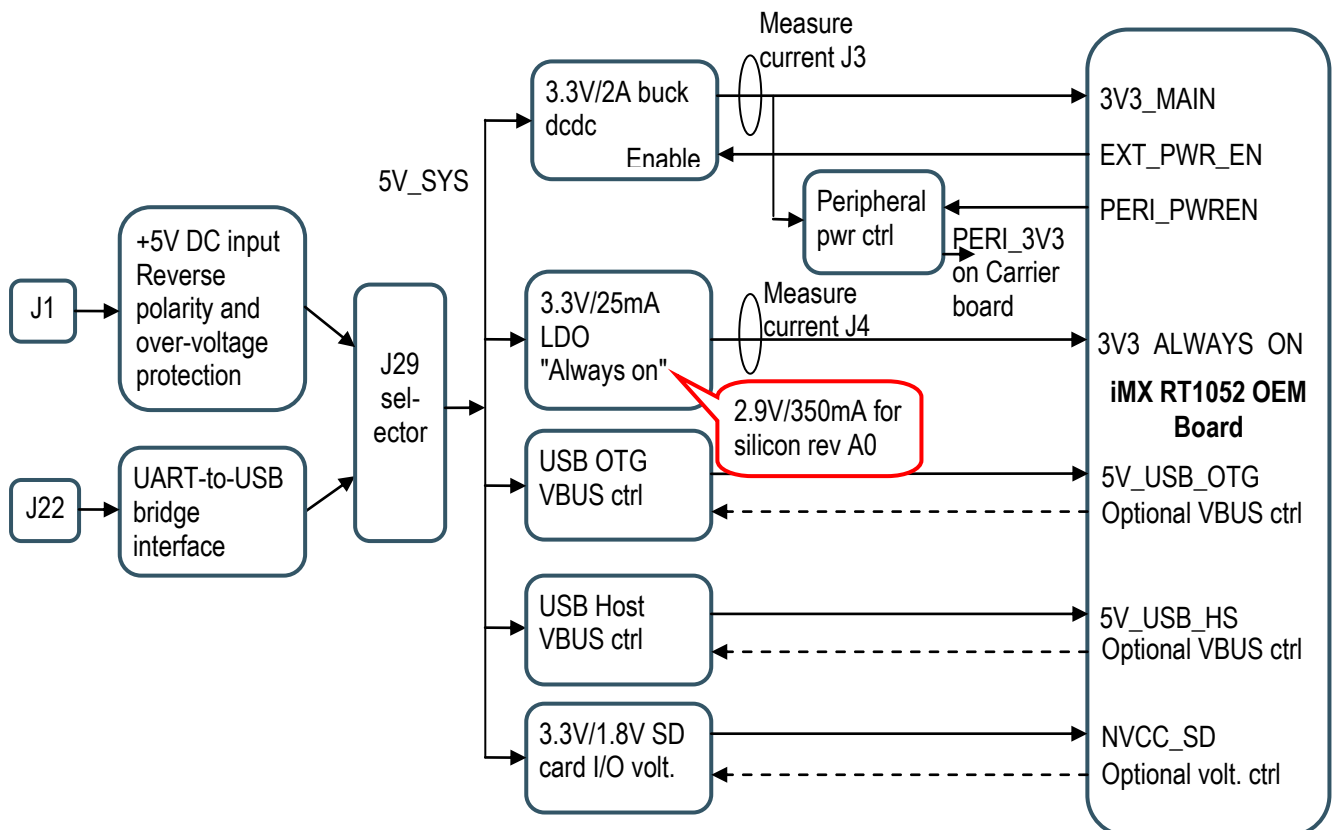

Figure 11 – Principal Powering Schematic



There are two voltage regulators:

- 3.3V/2A that is the main supply voltage for both the *iMX RT1052 OEM board* and the *iMX OEM Carrier board*.  
This is a buck dc/dc regulator to minimize power dissipation. The regulator can be switched on/off by control signal EXT\_PWR\_EN.
- 3.3V/25mA that is the secondary supply voltage that is "always on". It powers the VDD\_SNVS\_IN supply input on the i.MX RT1052. Current consumption is typically very low on this supply. This is a linear regulator.

Note that due to the erratas on i.MX RT1052 rev A0 silicon, the secondary supply voltage is 2.9V instead of 3.3V and it has much higher current rating (350 mA) than normally needed.

The *iMX OEM Carrier board* supports both 2.9 and 3.3V on VIN\_ALWAYS ON. When R25 (2.2Mohm) is mounted the voltage is 2.9V and when R25 is removed the voltage is 3.3V.

The picture below illustrates the location of relevant jumpers and LEDs.

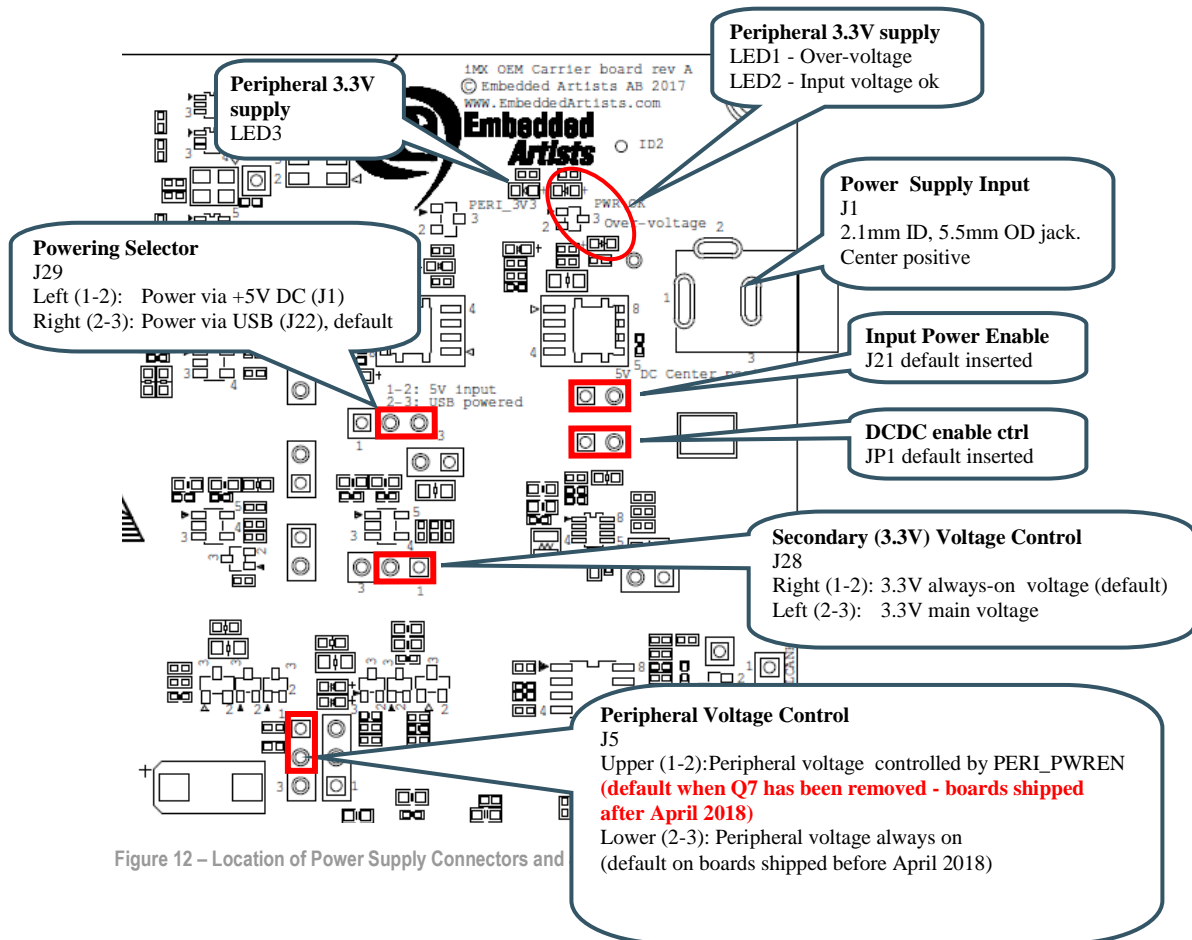

Figure 12 – Location of Power Supply Connectors and

### 4.3 SP2b: Current Measurement

It is possible to measure both the main and secondary supply currents on the *iMX OEM Carrier board*.

- J3 allows measuring the main 3.3V supply by measuring the voltage drop over a 100 milliohm resistor.
- J4 allows measuring the secondary 3.3V supply by measuring the voltage drop over a 500 milliohm resistor.

200 milliampere over a 100/500 milliohm resistor will give a 20/100 mV drop. A current sense series resistor is a trade-off between keeping the sense voltage high enough (in all operating conditions) while keeping the voltage drop low (in the highest current consumption). Insert the short circuit jumpers in J3 and J4, respectively, to remove the effect of the current sense resistors voltage drop.

It is possible to replace the series resistors with more suitable values for your specific application. The arrows indicate the current flow direction.

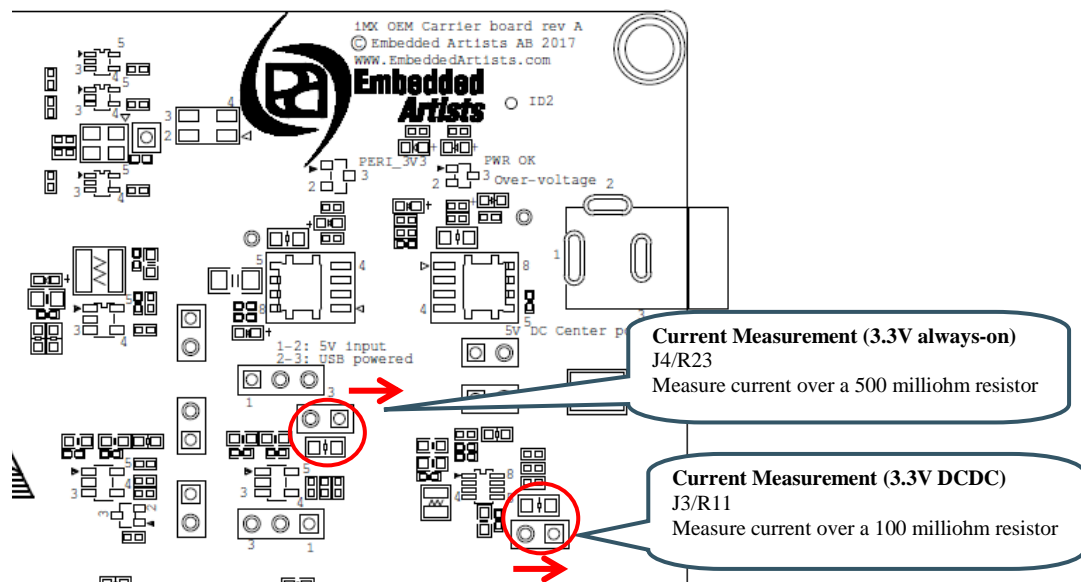

Figure 13 – Location of Current Measurement Connectors J3 and J4

Note that the main 3.3V supply powers both the *iMX RT1052 OEM board* and peripherals on the *iMX OEM Carrier board*, like LCD, SD interface, Audio codec, CAN interface, LEDs, etc. For better discrimination and resolution of current measurement, it is possible to measure currents on the *iMX RT1052 OEM board* also. The following detailed measurements of currents on the *iMX RT1052 OEM board* can be done:

- J1 allows measuring the 3.3V supply to DCDC\_IN by measuring the voltage drop over a 20 milliohm resistor.
- J2 allows measuring the VDD\_SOC\_IN core current by measuring the voltage drop over a 20 milliohm resistor.
- J3 allows measuring the 3.3V supply to VDD\_HIGH\_IN by measuring the voltage drop over a 20 milliohm resistor.
- J4 allows measuring the VBAT current to VDD\_SNVS\_IN by measuring the voltage drop over a 1 ohm resistor.
- J5 allows measuring the 3.3V supply to VDD\_ADC\_3P3 by measuring the voltage drop over a 20 milliohm resistor.

- J6 allows measuring the internal 1.8V supply to the EcoXiP flash by measuring the voltage drop over a 20 milliohm resistor.

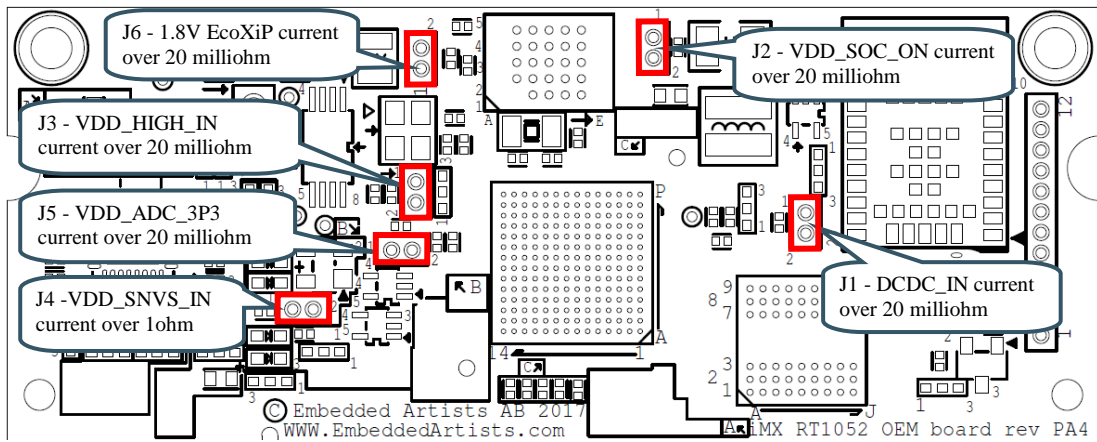

Figure 14 – Location of iMX RT1052 OEM Board Current Measurement Pads

#### 4.4 SP2c: VBAT Powering

The picture below illustrates where the VBAT input connector is (J2) and where the current can be measured over a 1 kohm resistor, J26. The arrow indicates the current flow direction.

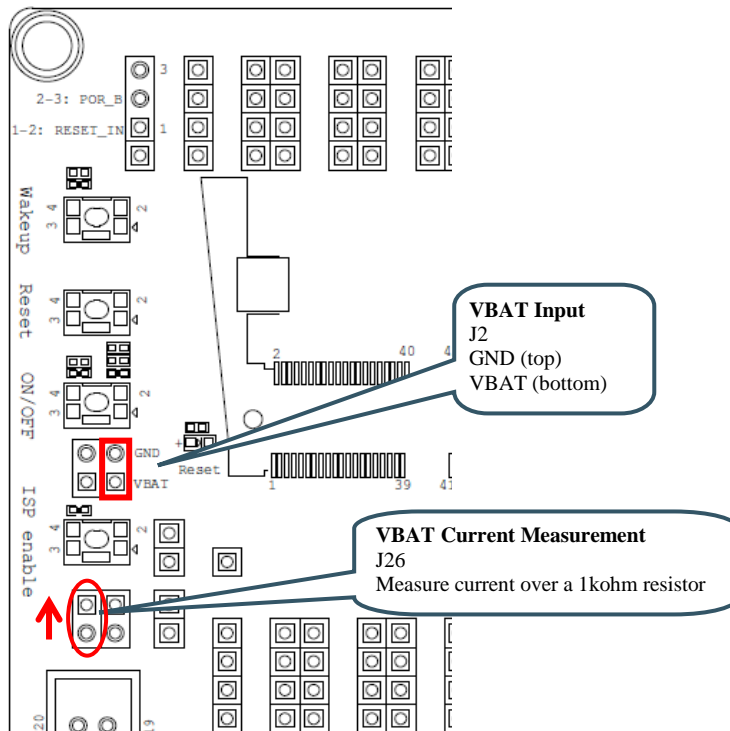

Figure 15 – Location of VBAT Connector and VBAT Current Measurement Pads

### 4.5 SP3-SP4: OEM Board Connector (SODIMM) and Access Pads

The *iMX RT1052 OEM board* connector is a standard DDR2 SO-DIMM socket with 200 positions and 0.6mm pitch. It has 1.8V keying (which is what DDR2 stands for). The JEDEC standard defining the DDR2 SODIMM boards is called JEDEC MO-224.

All relevant OEM board signals are available to access via the pads that are located in a 100 mil grid pattern around the SODIMM connector, J1. The access pads are located close to the SO-DIMM connectors in order to minimize track lengths.

Note that some *iMX OEM Carrier board* circuits may need to be disconnected before used externally. Carefully investigate the need for this before using a signal for external expansion.

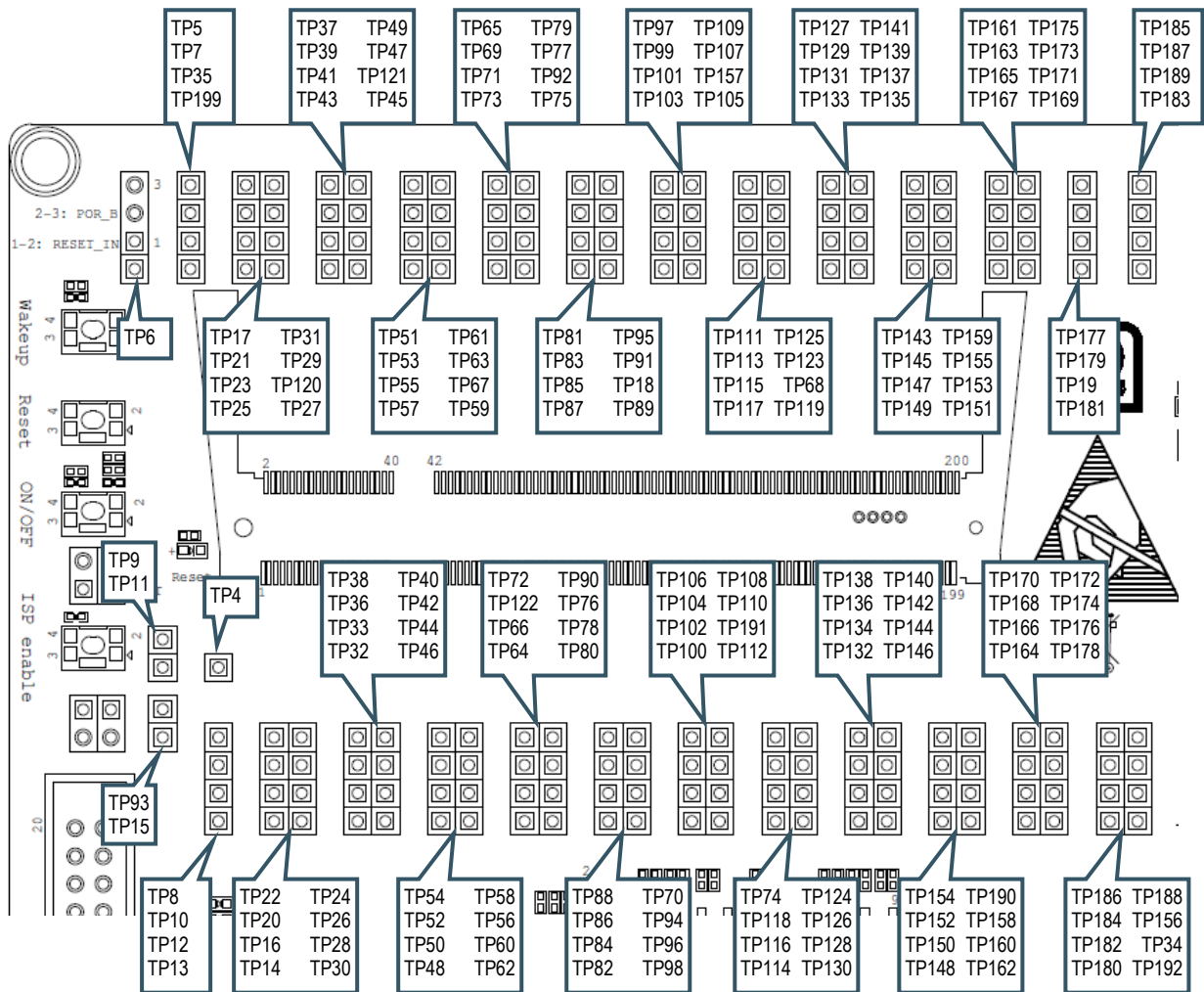

Figure 16 – Location of SODIMM connector, J1

### 4.6 SP5: Push-buttons and LEDs

There are four push-buttons, as presented in the picture below. The reset push-button, SW3, can be configured to control one of two different signals, via JP8.

- Jumper in 1-2 position on JP8, controls signal RESET\_IN, which results in a complete power cycle of main 3.3V power supply. This is the default jumper position.
- Jumper in 2-3 position on JP8, controls signal POR\_B, which results in a so called warm reset of the i.MX RT1052 MCU.

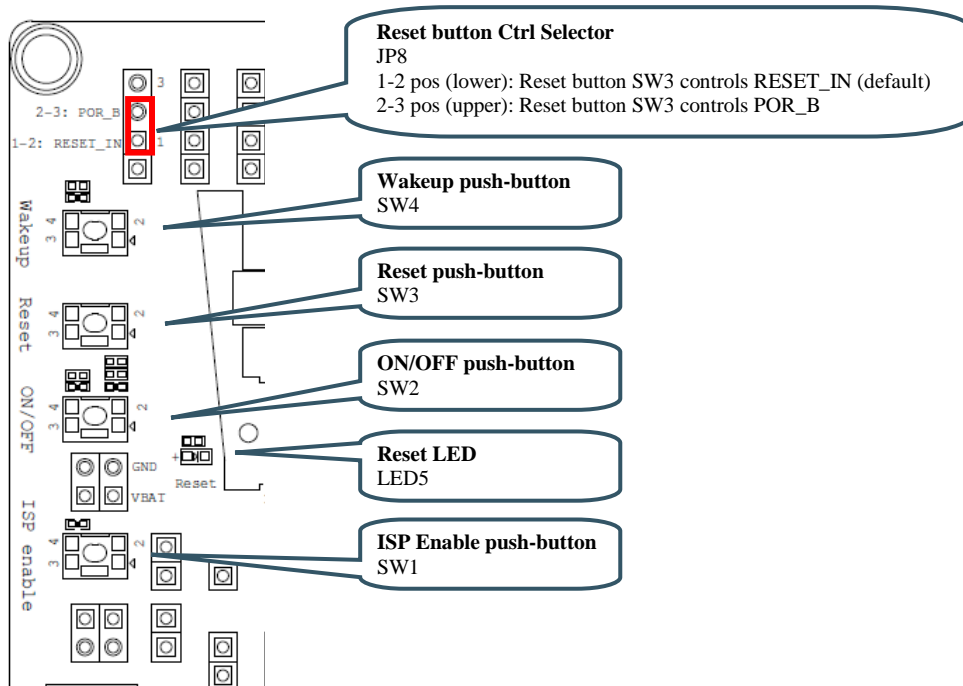

Figure 17 – Location of Push-buttons

There is also jumper to allow a specific signal (GPIO\_B1\_13) to control the watchdog input signal, WDOG\_B. This jumper is inserted by default.

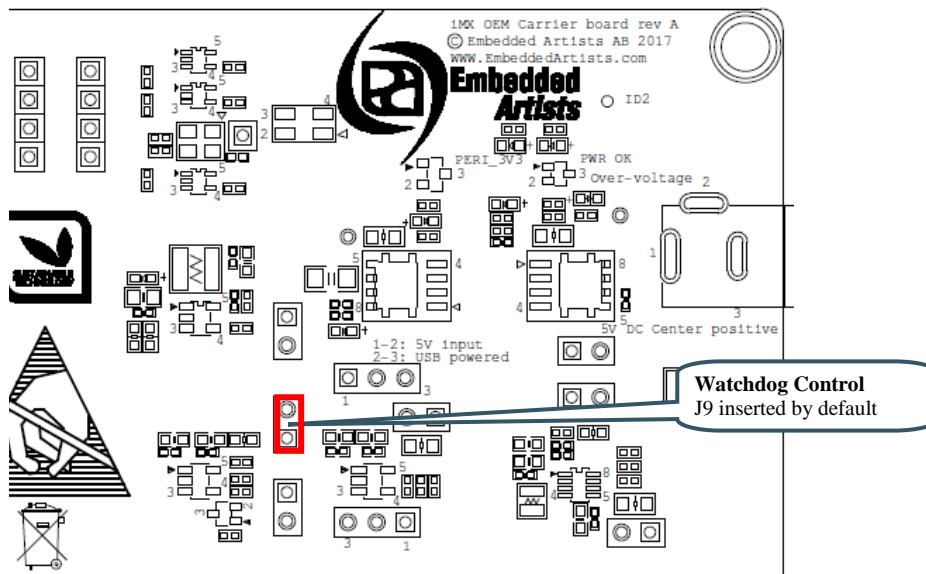

Figure 18 –Location of Watchdog Control Jumper, J9

There are two LEDs that are not connected by default to specific signals. Via jumpers to J8 any signal that is available on the access pads described in section 4.5 can be used to control the LEDs.

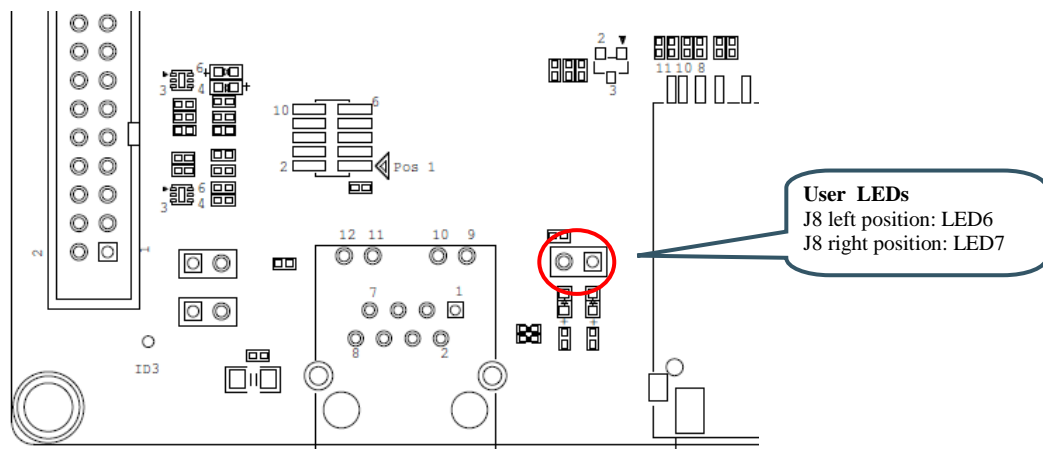

Figure 19 – Location of User LEDs

## 4.7 SP6: Debug Interfaces

There are two debug interface connectors available:

- J10 – this is a Cortex Debug connector. It is a 2x5 pos, 50 mil pitch connector without a shroud. Be careful when inserting the debug probe cable. Position 1 is specifically marked on the PCB silkscreen. It is located in the lower right corner, see Figure 20 below. The connector supports both the SWD and JTAG interfaces.
- J11 – this is an ARM Debug connector. It is a 2x10 pos, 100 mil pitch connector with shroud.

Both connector are defined and supports both the SWD and JTAG type of debug interfaces.

Note that in order to enable the JTAG/SWD interface on the i.MX RT1052, JP5 shall **not** be shorted/inserted.

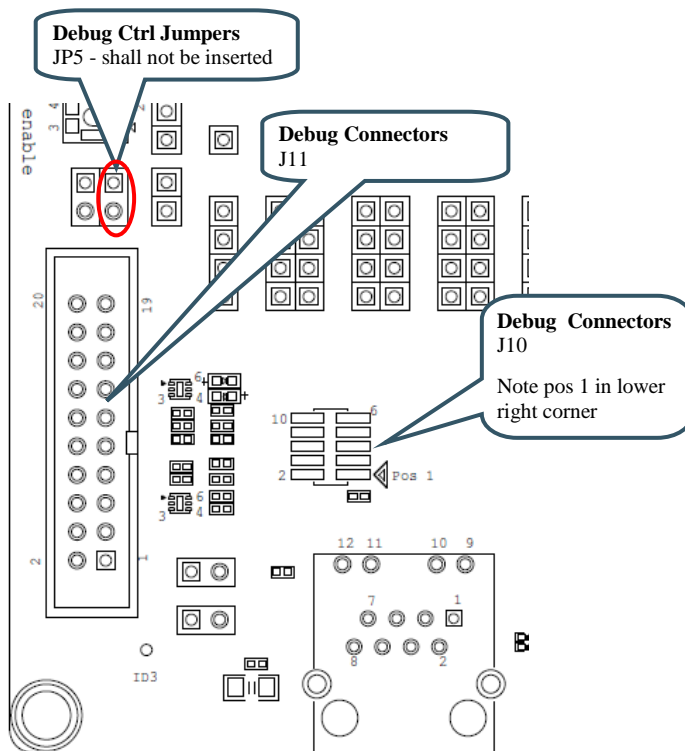

Figure 20 – Debug Interfaces

Note that due to the errata on i.MX RT1052 rev A0 silicon, the debug probe I/O voltage **MUST** follow the i.MX RT1052 I/O voltage.

The debug adapter must not drive any output higher than the Vcc/Vref voltage (and if that voltage is zero, then the debug adapter must not drive any output signal). Vcc/Vref is pin 1 on both J10 and J11.

Make sure the debug probe does not have a fixed output voltage, but rather follow Vcc/Vref. If using LPC-Link2 as debug interface, make sure there is **NO** jumper inserted in JP2.

Note about SWO trace:

Note that the i.MX RT1052 MCU does not connect the SWO trace output signal on JTAG\_TDO, which would be the normal (since JTAG\_TDO connect to the Cortex debug

connector where SWO is defined to be connected). Instead pin GPIO\_B0\_13-BOOT\_CFG2[1]-LCDIF\_D9 carries the SWO output as pin multiplexing alternative 2.

If you need to use SWO trace, the solution is to connect TP15 (JTAG\_TDO) and TP83 (GPIO\_B0\_13-BOOT\_CFG2[1]-LCDIF\_D9) with a wire. See Figure 16 to locate these two access pads.

Also, the SWO pin must be initialized correctly in file: `pin_mux.c`

Add the define below and add the call to `IOMUXC_SetPinMux()` and `IOMUXC_SetPinConfig()` in function `BOARD_InitPins()`, as outlined below.

```
#define IOMUXC_GPIO_B0_13_SWO 0x401F8170U, 0x2U, 0, 0, 0x401F8360U

void BOARD_InitPins(void) {
    ...
    /* GPIO_B0_13 is configured as SWO (ALT2)
       Sw Input On Field: Input Path is determined by functionality */
    IOMUXC_SetPinMux(
        IOMUXC_GPIO_B0_13_SWO,
        0U);

    /* GPIO_B0_13 PAD functional properties :
       Slew Rate Field: Fast Slew Rate
       Drive Strength Field: R0/6
       Speed Field: max(200MHz)
       Open Drain Enable Field: Open Drain Disabled
       Pull / Keep Enable Field: Pull/Keeper Enabled
       Pull / Keep Select Field: Keeper
       Pull Up / Down Config. Field: 100K Ohm Pull Down
       Hyst. Enable Field: Hysteresis Disabled */
    IOMUXC_SetPinConfig(
        IOMUXC_GPIO_B0_13_SWO,
        0x10F1u);
    ...
}
```



## 4.8 SP7: USB Interfaces

The *iMX OEM Carrier board* has two USB interfaces, one USB Host and one USB OTG:

- The USB Host interface has a USB-A connector, J13. By default this interface has VBUS power enable always on. LED8 indicates the presence of +5V VBUS for the interface. This USB interface is connected to i.MX RT1052 USB interface #2.
- The USB OTG interface has a micro-AB connector, J12. By default this interface has VBUS control via the ID-pin. This USB interface is connected to i.MX RT1052 USB interface #1.
  - If no cable is inserted or when a cable with ID pin floating is inserted, VBUS will not be powered on the J12 connector.
  - If a cable with the ID pin grounded is inserted VBUS will be turned on, i.e., powered with 5V. This is the typical situation when connecting a mini-AB to USB-A USB cable, i.e., when wanting the USB OTG interface to behave like a USB Host that can possibly also power an external device via VBUS.

See picture below for locating relevant components..

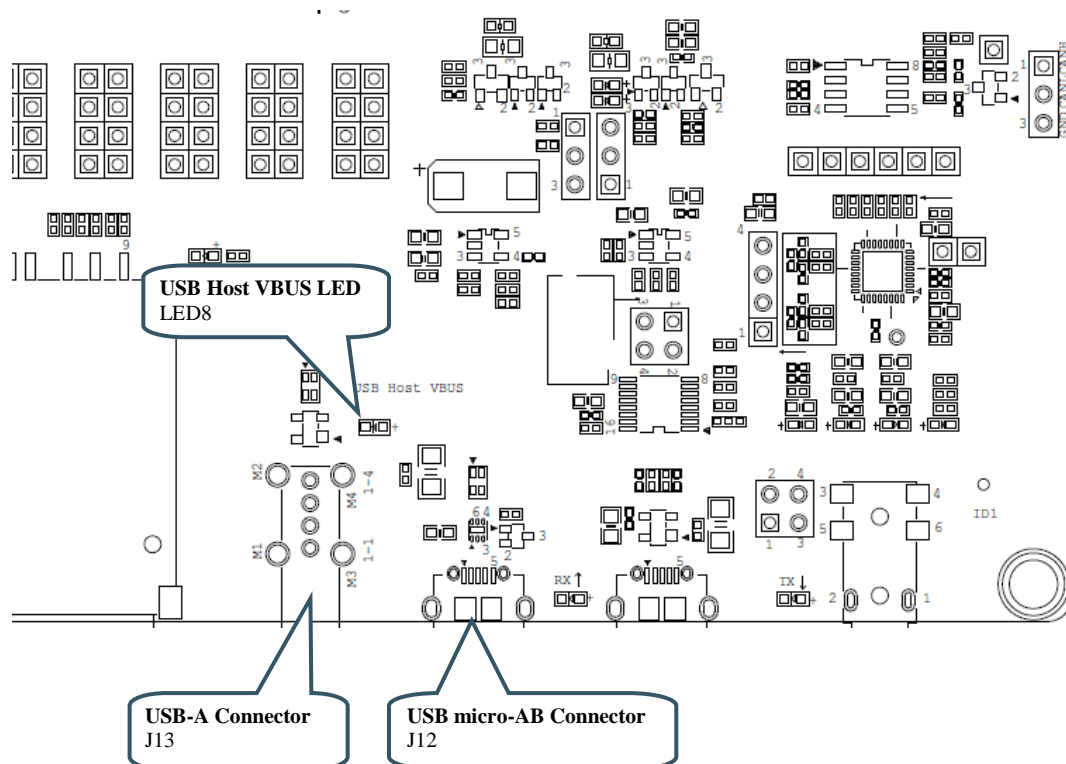

Figure 21 – Location of USB Interfaces

### 4.9 SP8: CAN

There is one CAN interface on the board. It is connected to FLEXCAN2 of the i.MX RT1052. The interface has on-board ESD protection via U9. See picture below for locating relevant components.

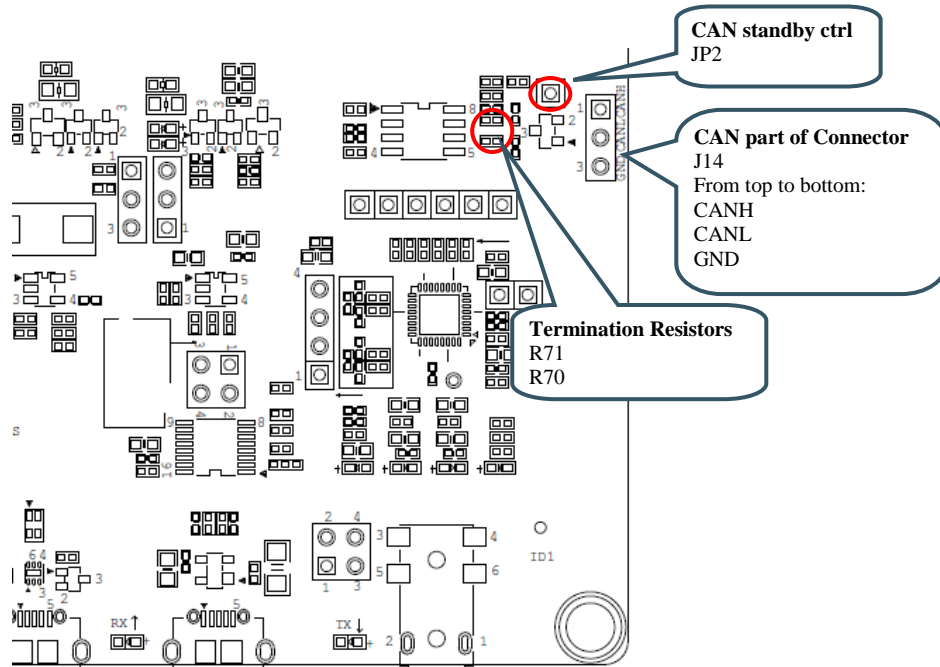

Figure 22 – CAN Interface

#### 4.10 SP9: SD Memory Card Interface

There is a SD memory card interface with SD card connector J15. The associated power switch is controlled by an (option) active high or active low signal. Additionally, signal POR\_B will power cycle the SD memory card. There is visual indication via LED9 that the memory card is powered.

The SD interface I/O voltage can optionally be controlled to be 3.3V or 1.8V. Insert a jumper in J16 to enable this control.

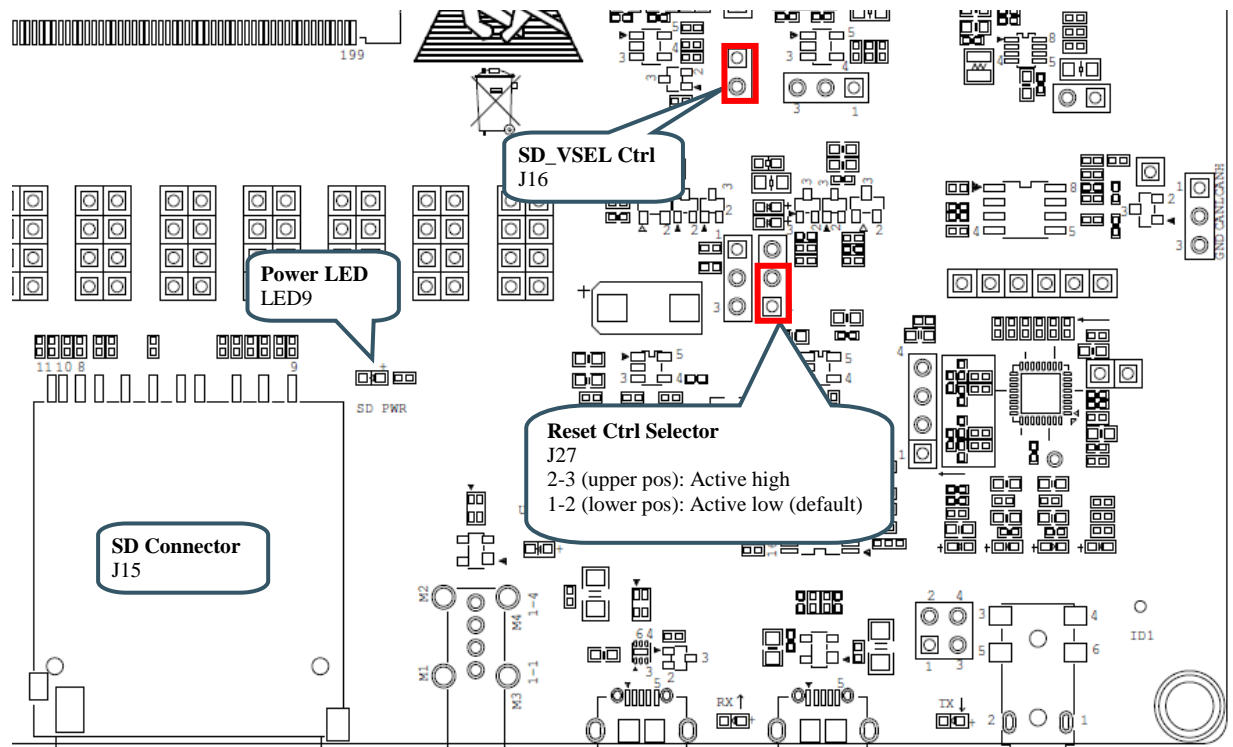

Figure 23 – SD Memory Card Interface

Due to signal integrity of the high-speed signals, three signals are not available per default at the TPx access pads described in section 4.5 . The stubs to the access pads are removed from the tracks by not having R150, R151 and R152 not mounted. The affected signals are:

GPIO\_SD\_B0\_01 - mount R150 to access the signal via TP69  
 GPIO\_SD\_B0\_03 - mount R151 to access the signal via TP73  
 GPIO\_SD\_B0\_05 - mount R152 to access the signal via TP75

R150-R152 can be found on the bottom side, just under the middle of the SODIMM connector and under the LCD. R150-R152 are 0 ohm 0402 resistors.

#### 4.11 SP10: LCD Interface

There is a 4.3 inch LCD with capacitive touch panel and 480x272 pixel resolution that is mounted on the bottom side. The 40 position FPC connector (J18) to the LCD has a relatively common pinning that will match many other LCDs. Since all relevant signals of the parallel RGB interface are available on the connector it can be used as a general display expansion connector - with the help of a small custom adapter board (to the display in mind).

The parallel RGB interface of the i.MX RT1052 is configured to 16-bit color depth (5 bits for red, 6 bits for green and 5 bits for blue).

Communication with the capacitive touch panel controller is done via I2C and two GPIOs, one for reset and one for interrupt.

There is a backlight current generator that is set to 40mA. It can optionally be controlled with a PWM signal to dim the backlight.

#### 4.12 SP11: Ethernet Interface

The board has an Ethernet interface, J20, which is a RJ45 connector with integrated magnetics. See picture below for where to find the location of J20.

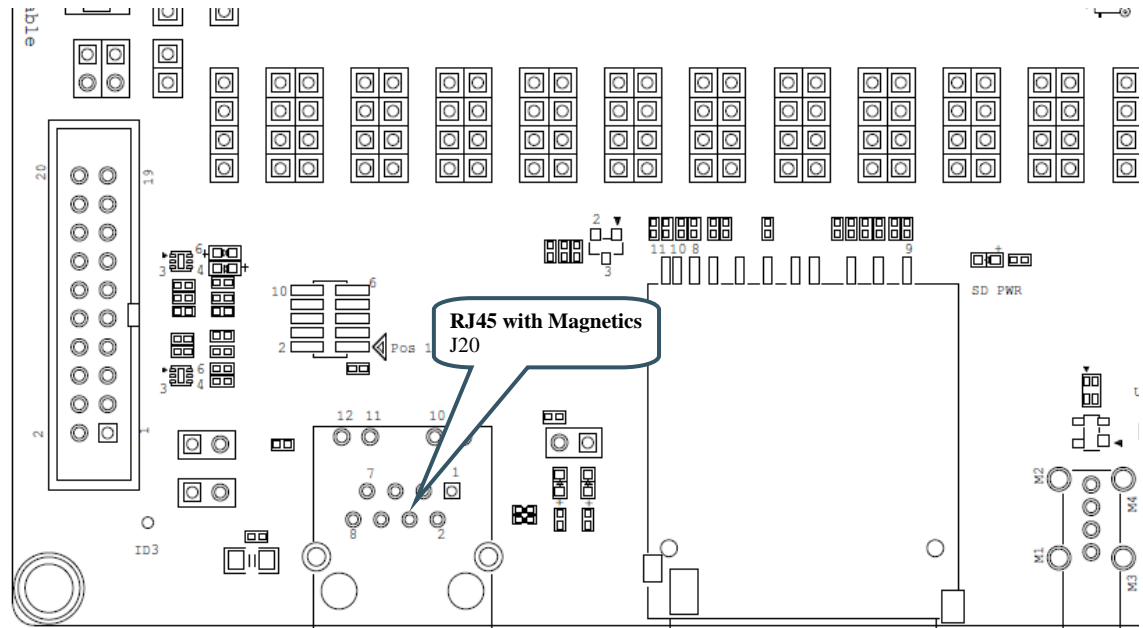

Figure 24 – Location of Ethernet Interface, J20

### 4.13 SP12: UART-to-USB Bridge

The UART-to-USB bridge chip (FT230XS-R from FTDI) on the *iMX OEM Carrier Board* connects to UART channel #1 on the i.MX RT1052. It exist to simplify connection to a PC because serial ports are not so common any more, especially not on laptops. The USB port also offers the possibility to power the board.

It is possible to disconnect the UART-to-USB bridge chip from UART channel #1 via JP3, for example if the UART needs to be connected to another device.

There are two LEDs, transmit from the board (LED11) and receive to the board (LED10), that signal communication activity.

See picture below for locating relevant components.

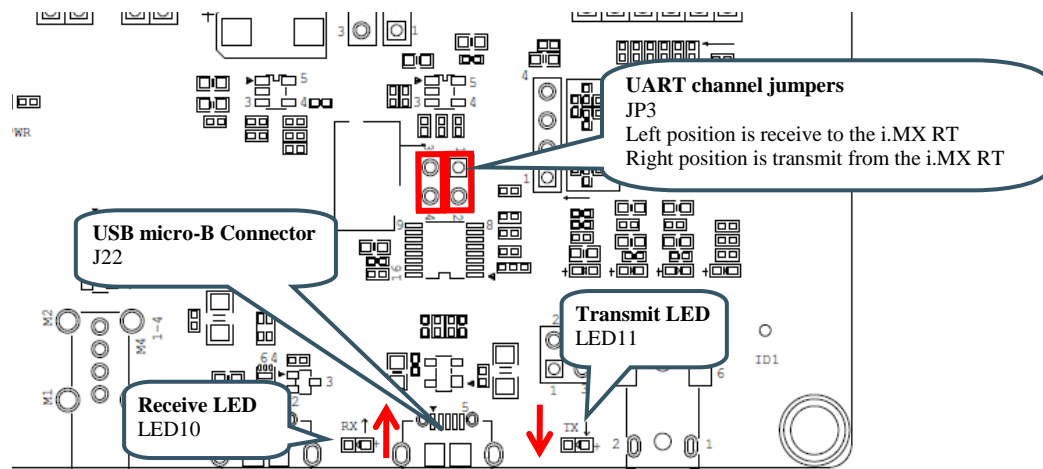

Figure 25 – UART-to-USB Bridge

#### 4.14 SP13: Audio Codec

The board contains an audio codec based on WM8960. The codec is controlled via I2C and audio data is transferred over the SAI bus with the I2S format.

The audio codec provides a mono microphone input, a stereo headphone output and an optional speaker output (via JP4).

The audio interface is via a 3.5 mm audio jack (J23) with four conductors (TRRS) supporting stereo sound and a microphone input. There are two types of signal allocation on the 3.5mm headphone connector. Location of ground and the microphone input signal differs. JP7 makes it possible to msockest

See picture below for locating relevant components.

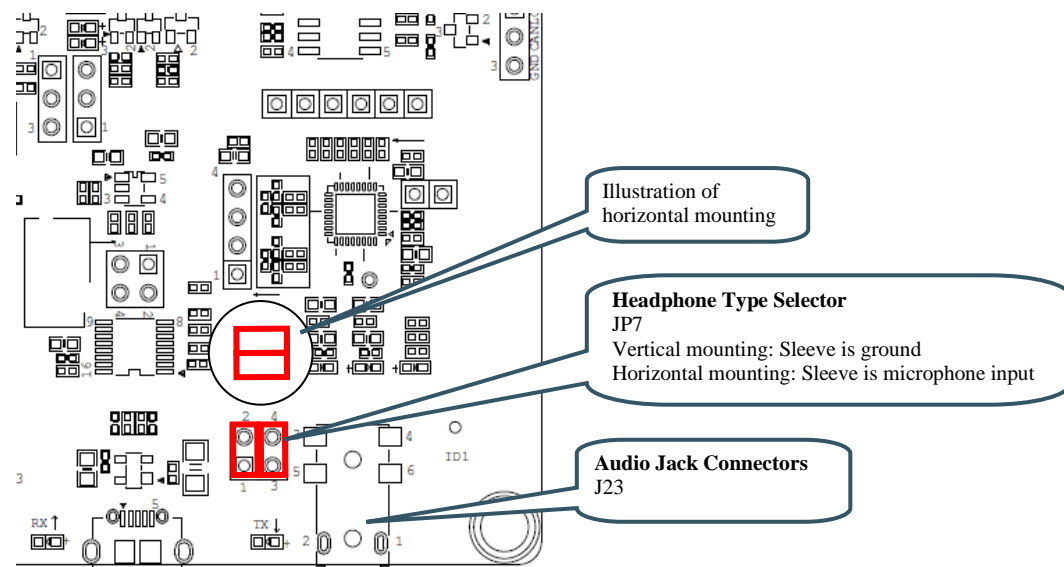

Figure 26 – I2S Audio Codec Interface

### 4.15 Default Jumpers Positions

Figure 27 illustrates the default jumper positions as mounted when the board is delivered from Embedded Artists. Default jumpers are marked with red color.

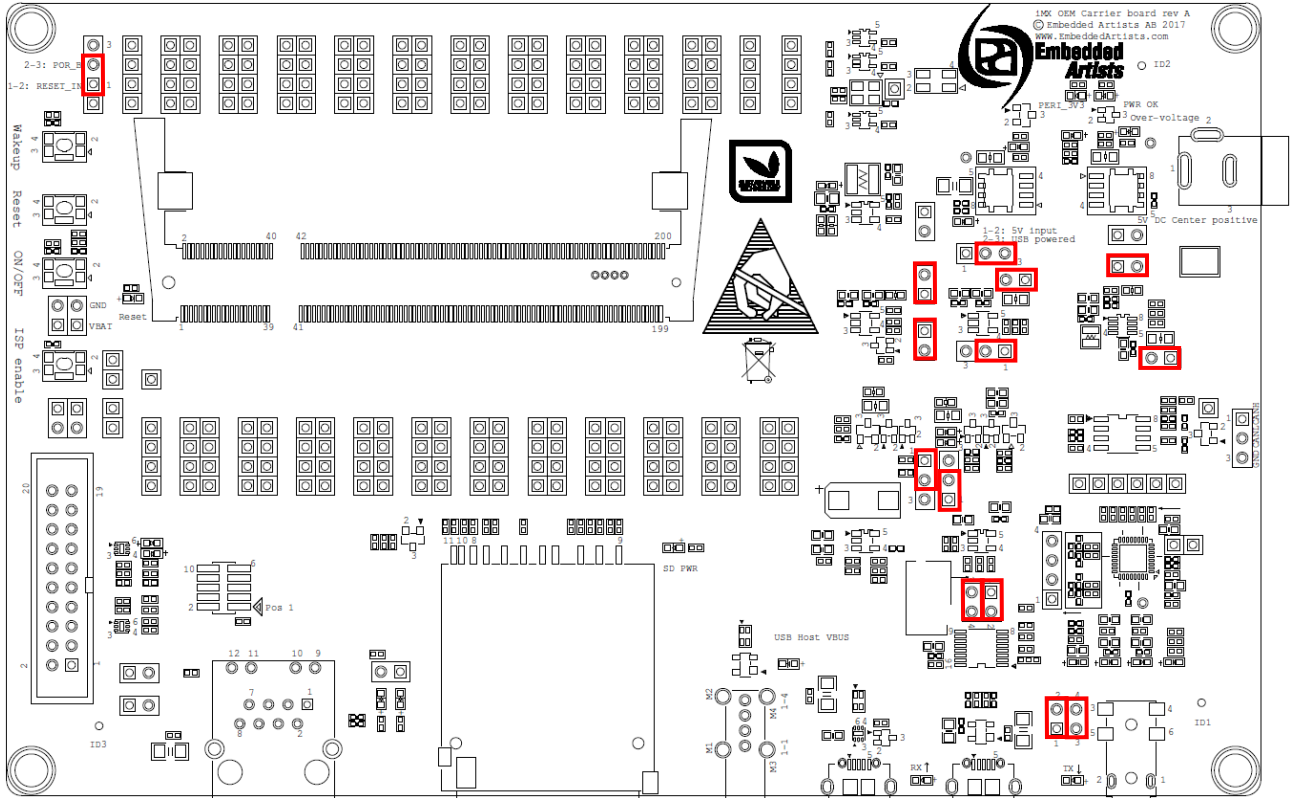

Figure 27 – iMX OEM Base Board Default Jumper Positions

#### 4.16 Usage of CPU Pins

Almost all pins of the i.MX RT1052 MCU are directly available on the SODIMM expansion connector. In a few cases are pins used for dedicated functionality like the Ethernet interface, EcoXiP interface and on-board SDRAM. These pins are not available on the SODIMM expansion connector. The table below lists all pins and their possible restrictions.

Before using a signal, make sure usage does not collide with functions on the *iMX OEM Carrier Board*.

<b><i>iMX OEM Carrier Board</i></b> <b>signal name</b>	<b><i>iMX RT1052 OEM</i></b> <b>Board signal name</b>	<b>Usage</b>
JTAG_DBGGEN-JTAG_MOD	GPIO_AD_B0_08	Signal is pulled low on the iMX OEM Carrier Board.
JTAG_TCK	GPIO_AD_B0_07	Connects to Arm/Cortex debug connectors.
JTAG_TRST	GPIO_AD_B0_11	Connects to Arm/Cortex debug connectors. Also function as interrupt signal from capacitive touch panel controller.
JTAG_TMS	GPIO_AD_B0_06	Connects to Arm/Cortex debug connectors.
JTAG_TDI	GPIO_AD_B0_09	Connects to Arm/Cortex debug connectors.
JTAG_TDO	GPIO_AD_B0_10	Connects to Arm/Cortex debug connectors.
GPIO0-LCDIF_PWREN	GPIO_AD_B0_04	No special usage on <i>iMX OEM Carrier Board</i>
GPIO2-LCDIF_CLK	GPIO_B0_00	Parallel RGB LCD interface - LPC Pixel Clock
GPIO3-LCDIF_VSYNC	GPIO_B0_03	Parallel RGB LCD interface - LPC VSYNC
GPIO4-LCDIF_ENABLE	GPIO_B0_01	Parallel RGB LCD interface - LPC Data Enable
GPIO5-LCDIF_HSYNC	GPIO_B0_02	Parallel RGB LCD interface - LPC HSYNC
GPIO6-LCDIF_D12	GPIO_B1_00	Parallel RGB LCD interface - Red4 bit
GPIO7-LCDIF_D13	GPIO_B1_01	Parallel RGB LCD interface - Red5 bit
GPIO8-LCDIF_D14	GPIO_B1_02	Parallel RGB LCD interface - Red6 bit
GPIO9-LCDIF_D15	GPIO_B1_03	Parallel RGB LCD interface - Red7 bit
USBA-DP/DM	OTG1-DP/DM	Connects to a USB OTG interface
USBB-DP/DM	OTG2-DP/DM	Connects to a USB Host interface
GPIO_B0_15-BOOT_CFG2[3]- LCDIF_D11	GPIO_B0_15	Parallel RGB LCD interface - Red3 bit
GPIO_B0_04-BOOT_CFG1[0]- LCDIF_D0	GPIO_B0_04	Parallel RGB LCD interface - Blue3 bit
GPIO_AD_B0_15- FLEXCAN2_RX	GPIO_AD_B0_15	Connects to RD on CAN transceiver
GPIO_AD_B0_14- FLEXCAN2_TX	GPIO_AD_B0_14	Connects to TD on CAN transceiver
GPIO_AD_B0_12- LPUART1_TX	GPIO_AD_B0_12	Connects to UART-to-USB bridge (U1_TXD).
GPIO_AD_B0_13- LPUART1_RX	GPIO_AD_B0_13	Connects to UART-to-USB bridge (U1_RXD).



GPIO_AD_B1_10-SAI1_RX_SYNC	GPIO_AD_B1_10	No special usage on <i>iMX OEM Carrier Board</i> .
GPIO_AD_B1_11-SAI1_RX_BCLK	GPIO_AD_B1_11	No special usage on <i>iMX OEM Carrier Board</i> .
GPIO_AD_B0_02-USB_OTG1_PWR	GPIO_AD_B0_02	Connects to reset input to capacitive touch panel controller.  Can optionally control USB OTG VBUS power switch.
GPIO_AD_B0_03-USB_OTG1_OC	GPIO_AD_B0_03	Connects to USB OTG interface - Over-current flag
GPIO_AD_B0_01-USB_OTG1_ID	GPIO_AD_B0_01	Connects to USB OTG interface - ID pin
GPIO_AD_B0_00-USB_HOST_OC	GPIO_AD_B0_00	Connects to USB Host interface - Over-current flag
GPIO_AD_B1_08-AUD_INT	GPIO_AD_B1_08	Connects to audio codec interrupt.
GPIO_B1_12-SD_CD	GPIO_B1_12	Connects to SD interface card detect.
GPIO_AD_B1_01-I2C1_SDA	GPIO_AD_B1_01	I2C-SDA, connects to audio codec and capacitive touch panel controller.
GPIO_AD_B1_00-I2C1_SCL	GPIO_AD_B1_00	I2C-SCL, connects to audio codec and capacitive touch panel controller.
GPIO_SD_B0_01-SD1_CLK	GPIO_SD_B0_01	Connects to SD interface - CLK
GPIO_SD_B0_00-SD1_CMD	GPIO_SD_B0_00	Connects to SD interface - CMD
GPIO_AD_B0_05-BOOT_MODE1-FLASH_RST	GPIO_AD_B0_05	Connects to SD interface - power control
GPIO_SD_B0_02-SD1_D0	GPIO_SD_B0_02	Connects to SD interface - Data0
GPIO_SD_B0_03-SD1_D1	GPIO_SD_B0_03	Connects to SD interface - Data1
GPIO_SD_B0_04-SD1_D2	GPIO_SD_B0_04	Connects to SD interface - Data2
GPIO_SD_B0_05-SD1_D3	GPIO_SD_B0_05	Connects to SD interface - Data3
GPIO_B1_15-LCD_BL_CTL-USB_HOST_PWR	GPIO_B1_15	Controls LCD backlight voltage generator.  Can optionally connect to control USB Host VBUS power switch.
GPIO_B1_14-SD_VSEL	GPIO_B1_14	Can optionally (via J16) control 3.3V/1.8V IO supply voltage for the SD interface on the i.MX RT1052.
GPIO_B0_09-BOOT_CFG1[5]-LCDIF_D5	GPIO_B0_09	Parallel RGB LCD interface - Green2 bit
GPIO_B0_10-BOOT_CFG1[6]-LCDIF_D6	GPIO_B0_10	Parallel RGB LCD interface - Green3 bit
GPIO_B0_11-BOOT_CFG1[7]-LCDIF_D7	GPIO_B0_11	Parallel RGB LCD interface - Green4 bit
GPIO_B0_12-BOOT_CFG2[0]-LCDIF_D8	GPIO_B0_12	Parallel RGB LCD interface - Green5 bit

GPIO_B0_13-BOOT_CFG2[1]-LCDIF_D9	GPIO_B0_13	Parallel RGB LCD interface - Green6 bit
GPIO_B0_14-BOOT_CFG2[2]-LCDIF_D10	GPIO_B0_14	Parallel RGB LCD interface - Green7 bit
GPIO_B0_05-BOOT_CFG1[1]-LCDIF_D1	GPIO_B0_05	Parallel RGB LCD interface - Blue4 bit
GPIO_B0_06-BOOT_CFG1[2]-LCDIF_D2	GPIO_B0_06	Parallel RGB LCD interface - Blue5 bit
GPIO_B0_07-BOOT_CFG1[3]-LCDIF_D3	GPIO_B0_07	Parallel RGB LCD interface - Blue6 bit
GPIO_B0_08-BOOT_CFG1[4]-LCDIF_D4	GPIO_B0_08	Parallel RGB LCD interface - Blue7 bit
GPIO_AD_B1_14-SAI1_TX_BCLK	GPIO_AD_B1_14	Connects to audio codec: TX_BCLK
GPIO_AD_B1_13-SAI1_TXD	GPIO_AD_B1_13	Connects to audio codec: TX_DATA
GPIO_AD_B1_15-SAI1_TX_SYNC	GPIO_AD_B1_15	Connects to audio codec: TX_SYNC
GPIO_SD_B1_04-FLEXSPI_CLK_B	GPIO_SD_B1_04	No special usage on <i>iMX OEM Carrier Board</i> .
GPIO_AD_B1_12-SAI1_RXD	GPIO_AD_B1_12	Connects to audio codec: RX_DATA
POR_B	POR_B	No special usage on <i>iMX OEM Carrier Board</i> . Can optionally be controlled by SW3 if JP8 is in 2-3 pos.
ONOFF	ONOFF	Connects to push-button SW2
OTG1_CHD	OTG1_CHD	No special usage on <i>iMX OEM Carrier Board</i> .
WAKEUP	WAKEUP	Connects to push-button SW4
GPIO_AD_B1_09-SAI1_MCLK	GPIO_AD_B1_09	Connects to audio codec: MCLK
PMIC_ON_REQ	PMIC_ON_REQ + Reset generator	No special usage on <i>iMX OEM Carrier Board</i> .
EXT_PWR_EN	PMIC_REQ_ON	Enables the main 3.3V power supply.
PERI_PWREN	PMIC_STBY_REQ	Enables the 3.3V peripheral voltage supply.
GPIO_B1_13-WDOG_B	GPIO_B1_13	Is connected to WDOG_B input via J9.
GPIO_AD_B1_02	GPIO_AD_B1_02	No special usage on <i>iMX OEM Carrier Board</i> .
GPIO_AD_B1_03	GPIO_AD_B1_03	No special usage on <i>iMX OEM Carrier Board</i> .
GPIO_AD_B1_04	GPIO_AD_B1_04	No special usage on <i>iMX OEM Carrier Board</i> .
GPIO_AD_B1_05	GPIO_AD_B1_05	No special usage on <i>iMX OEM Carrier Board</i> .
GPIO_AD_B1_06	GPIO_AD_B1_06	No special usage on <i>iMX OEM Carrier Board</i> .
GPIO_AD_B1_07	GPIO_AD_B1_07	No special usage on <i>iMX OEM Carrier Board</i> .
CCM_CLK1_P/_N	CCM_CLK1_P/_N	No special usage on <i>iMX OEM Carrier Board</i> .

## 4.17 Things to Note

This section lists things to note when using the *iMX RT1052 Developer's Kit*.

### 4.17.1 Errata on i.MX RT1052 silicon rev A0

*iMX RT1052 OEM boards revision A*, and later (typically shipped after April 2018) are built with i.MX RT1052 silicon revision A1 and **are not** affected by the powering erratas referring to below.

*iMX RT1052 OEM boards revision PA4* (typically shipped before April 2018) are built with i.MX RT1052 silicon revision A0 and **are** affected by the powering erratas referring to below.

There are some serious erratas related to powering on i.MX RT1052 rev A0 silicon.

**Extra special care must be observed. Failure to observe the jumpers settings and the other procedures described can result in irreversible damage to the i.MX RT1052.**

Keep all jumpers inserted while the board is powered. Do not change/experiment with other jumper settings. It can result in irreversible damage to the i.MX RT1052 microcontroller.

Note that due to the erratas on i.MX RT1052 rev A0 silicon, the secondary (always-on) supply voltage is 2.9V instead of 3.3V and it has much higher current rating (350 mA) than normally needed. It also starts up before the main 3.3V power supply.

Also note that due to the errata on i.MX RT1052 rev A0 silicon, the debug probe I/O voltage **MUST** follow the i.MX RT1052 I/O voltage.

The debug adapter must not drive any output higher than the Vcc/Vref voltage (and if that voltage is zero, then the debug adapter must not drive any output signal). Vcc/Vref is pin 1 on both J10 and J11.

Make sure the debug probe does not have a fixed output voltage, but rather follow Vcc/Vref. If using LPC-Link2 as debug interface, make sure there is **NO** jumper inserted in JP2.

**If you ever observe that the i.MX RT1052 becomes very hot, immediately remove power to the i.MX RT1052 Developer's Kit and let it cool. Verify that jumper settings are correct before powering up the board again.**

### 4.17.2 Three signals in SD interface not available at TPx access pads

Due to signal integrity of the high-speed signals, three signals are not available per default at the TPx access pads described in section 4.5. The stubs to the access pads are removed from the tracks by not having R150, R151 and R152 not mounted. The affected signals are:

GPIO\_SD\_B0\_01 - mount R150 to access the signal via TP69

GPIO\_SD\_B0\_03 - mount R151 to access the signal via TP73

GPIO\_SD\_B0\_05 - mount R152 to access the signal via TP75

R150-R152 can be found on the bottom side, just under the middle of the SODIMM connector and under the LCD. R150-R152 are 0 ohm 0402 resistors.

## 5 Troubleshooting

This chapter contains information about how to troubleshoot boards that does not seem to operate properly. It is strongly advised to read through the list of tests and actions that can be done before contacting Embedded Artists. The different tests can help determine if there is a problem with the board, or not. For return policy, please read Embedded Artists' General Terms and Conditions document (can be found at <http://www.embeddedartists.com/shop/>).

### 5.1 No SWD/JTAG Connection

Note that JP5 shall not be shorted/inserted. Verify correct orientation when using the Cortex Debug connector (2x5 pos, 50 mil pitch connector).

### 5.2 Powering

The first step is to make sure that powering works properly.

1. Make sure all jumpers are in default position, see section 4.15 for details.
2. Power the board via the micro-AB USB connector, J22, also known as position 1) in Figure 1.
3. Verify that you can measure 5V  $\pm$ 0.3V on the jumper in J29 and that LED2 is on.
4. Verify that you have 2.8V - 3.4V on any of the pins of J4. This is the always-on voltage supply. (Due to the i.MX RT1052 errata on silicon revision rev A0 the voltage is 2.9V nominal on boards delivered before April 2018. It is 3.3V in boards delivered after April 2018.) Verify that the voltage measured over J4 is less than 25 mV.
5. Verify that you have 3.3V  $\pm$ 0.15V on any of the pins of J3. This is the main voltage supply. Also verify that LED3 is on. Verify that the voltage measured over J3 is less than 50 mV.
6. Press the reset push-button, SW3. Verify that LED3 is off while pressing SW3.
7. Press the ON/OFF push-button, SW2, for 5 seconds. Verify that LED3 is turned off after the 5 seconds. Press the button again for a short while and LED3 will turn on again.

### 5.3 Contact with OEM Board MCU

The second step is to make sure it is possible to download an application to the i.MX RT1052 MCU on the *OEM Board* is working. Follow the instructions found in the *iMX RT1052 Developer's Kit Program Development Guide* to download the demo application. This can be used without a debug probe. Alternatively download any of the sample applications via any of the supported IDEs.

This test verifies that the i.MX RT1052 is operating properly.

### 5.4 Using the Demo Application to Verify Correct Operation

The third step is to run the just downloaded demo application. There are many tests that can be performed, one after one, to verify correct operation of individual parts of the *iMX RT1052 OEM Board* as well as the *iMX OEM Carrier Board*. While doing these tests, be sure to not have any interfering circuits connected to the access pads.

## 6 Different Board Versions

The different board versions, silicon versions and MCU top side marking have overlapping and sometimes confusing versions numbers. Therefore, this chapter contains information about different board versions and i.MX RT1052 silicon versions.

<b>iMX RT1052 OEM Board version</b>	<b>i.MX RT1052 Silicon Version</b>	<b>i.MX RT1052 Top Marking</b>
<b>iMX RT1052 OEM Board, rev PA4</b>	<b>A0</b>	<b>PIMXRT1052DVL6A (comm.) PIMXRT1052CVL5A (ind.)</b>
<b>iMX RT1052 OEM Board, rev A1 and A2</b> Rev A1 is a board with SDRAM Rev A2 is a board without SDRAM	<b>A1</b>	<b>MIMXRT1052DVL6B (comm.) MIMXRT1052CVL5B (ind.)</b>

## 7 Disclaimers

Embedded Artists reserves the right to make changes to information published in this document, including, without limitation, specifications and product descriptions, at any time and without notice. This document supersedes and replaces all information supplied prior to the publication hereof.

Customer is responsible for the design and operation of their applications and products using Embedded Artists' products, and Embedded Artists accepts no liability for any assistance with applications or customer product design. It is customer's sole responsibility to determine whether the Embedded Artists' product is suitable and fit for the customer's applications and products planned, as well as for the planned application and use of customer's third party customer(s). Customers should provide appropriate design and operating safeguards to minimize the risks associated with their applications and products. Customer is required to have expertise in electrical engineering and computer engineering for the installation and use of Embedded Artists' products.

Embedded Artists does not accept any liability related to any default, damage, costs or problem which is based on any weakness or default in the customer's applications or products, or the application or use by customer's third party customer(s). Customer is responsible for doing all necessary testing for the customer's applications and products using Embedded Artists' products in order to avoid a default of the applications and the products or of the application or use by customer's third party customer(s). Embedded Artists does not accept any liability in this respect.

Embedded Artists does not accept any liability for errata on individual components. Customer is responsible to make sure all errata published by the manufacturer of each component are taken note of. The manufacturer's advice should be followed.

Embedded Artists does not accept any liability and no warranty is given for any unexpected software behavior due to deficient components.

Customer is required to take note of manufacturer's specification of used components, for example MCU, SDRAM and FLASH. Such specifications, if applicable, contains additional information that must be taken note of for the safe and reliable operation. These documents are stored on Embedded Artists' product support page.

All Embedded Artists' products are sold pursuant to Embedded Artists' terms and conditions of sale: [http://www.embeddedartists.com/sites/default/files/docs/General\\_Terms\\_and\\_Conditions.pdf](http://www.embeddedartists.com/sites/default/files/docs/General_Terms_and_Conditions.pdf)

No license, express or implied, by estoppel or otherwise, to any intellectual property rights is granted under this document. If any part of this document refers to any third party products or services it shall not be deemed a license grant by Embedded Artists for the use of such third party products or services, or any intellectual property contained therein or considered as a warranty covering the use in any manner whatsoever of such third party products or services or any intellectual property contained therein.

UNLESS OTHERWISE SET FORTH IN EMBEDDED ARTISTS' TERMS AND CONDITIONS OF SALE EMBEDDED ARTISTS DISCLAIMS ANY EXPRESS OR IMPLIED WARRANTY WITH RESPECT TO THE USE AND/OR SALE OF EMBEDDED ARTISTS PRODUCTS INCLUDING WITHOUT LIMITATION IMPLIED WARRANTIES OF MERCHANTABILITY, FITNESS FOR A PARTICULAR PURPOSE (AND THEIR EQUIVALENTS UNDER THE LAWS OF ANY JURISDICTION), OR INFRINGEMENT OF ANY PATENT, COPYRIGHT OR OTHER INTELLECTUAL PROPERTY RIGHT.

UNLESS EXPRESSLY APPROVED IN WRITING BY THE CEO OF EMBEDDED ARTISTS, PRODUCTS ARE NOT RECOMMENDED, AUTHORIZED OR WARRANTED FOR USE IN MILITARY, AIR CRAFT, SPACE, NUCLEAR, LIFE SAVING, OR LIFE SUSTAINING APPLICATIONS, NOR IN PRODUCTS OR SYSTEMS WHERE FAILURE OR MALFUNCTION MAY RESULT IN PERSONAL INJURY, DEATH, OR SEVERE PROPERTY OR ENVIRONMENTAL DAMAGE.

Resale of Embedded Artists' products with provisions different from the statements and/or technical features set forth in this document shall immediately void any warranty granted by Embedded Artists

for the Embedded Artists' product or service described herein and shall not create or extend in any manner whatsoever, any liability of Embedded Artists.

This document as well as the item(s) described herein may be subject to export control regulations. Export might require a prior authorization from national authorities.

### 7.1 Definition of Document Status

**Preliminary** – The document is a draft version only. The content is still under internal review and subject to formal approval, which may result in modifications or additions. Embedded Artists does not give any representations or warranties as to the accuracy or completeness of information included herein and shall have no liability for the consequences of use of such information. The document is in this state until the product has passed Embedded Artists product qualification tests.

**Approved** – The information and data provided define the specification of the product as agreed between Embedded Artists and its customer, unless Embedded Artists and customer have explicitly agreed otherwise in writing.



**Стандарт  
Электрон  
Связь**

Мы молодая и активно развивающаяся компания в области поставок электронных компонентов. Мы поставляем электронные компоненты отечественного и импортного производства напрямую от производителей и с крупнейших складов мира.

Благодаря сотрудничеству с мировыми поставщиками мы осуществляем комплексные и плановые поставки широчайшего спектра электронных компонентов.

Собственная эффективная логистика и склад в обеспечивает надежную поставку продукции в точно указанные сроки по всей России.

Мы осуществляем техническую поддержку нашим клиентам и предпродажную проверку качества продукции. На все поставляемые продукты мы предоставляем гарантию .

Осуществляем поставки продукции под контролем ВП МО РФ на предприятия военно-промышленного комплекса России , а также работаем в рамках 275 ФЗ с открытием отдельных счетов в уполномоченном банке. Система менеджмента качества компании соответствует требованиям ГОСТ ISO 9001.

Минимальные сроки поставки, гибкие цены, неограниченный ассортимент и индивидуальный подход к клиентам являются основой для выстраивания долгосрочного и эффективного сотрудничества с предприятиями радиоэлектронной промышленности, предприятиями ВПК и научно-исследовательскими институтами России.

С нами вы становитесь еще успешнее!

**Наши контакты:**

**Телефон:** +7 812 627 14 35

**Электронная почта:** [sales@st-electron.ru](mailto:sales@st-electron.ru)

**Адрес:** 198099, Санкт-Петербург,  
Промышленная ул, дом № 19, литера Н,  
помещение 100-Н Офис 331