

Analog Devices Welcomes Hittite Microwave Corporation

NO CONTENT ON THE ATTACHED DOCUMENT HAS CHANGED



THIS PAGE INTENTIONALLY LEFT BLANK

GaAs MMIC SP4T NON-REFLECTIVE SWITCH, DC - 8 GHz

Typical Applications

The HMC344 is ideal for:

- Telecom Infrastructure
- Microwave Radio & VSAT
- Military & Space
- Test Instrumentation

Features

- Broadband Performance: DC - 8 GHz
- Non-Reflective Topology
- Low Insertion Loss: 1.8 dB @ 6 GHz
- Integrated 2:4 TTL Decoder
- Small Size: 1.08 x 1.05 x 0.10 mm

Functional Diagram

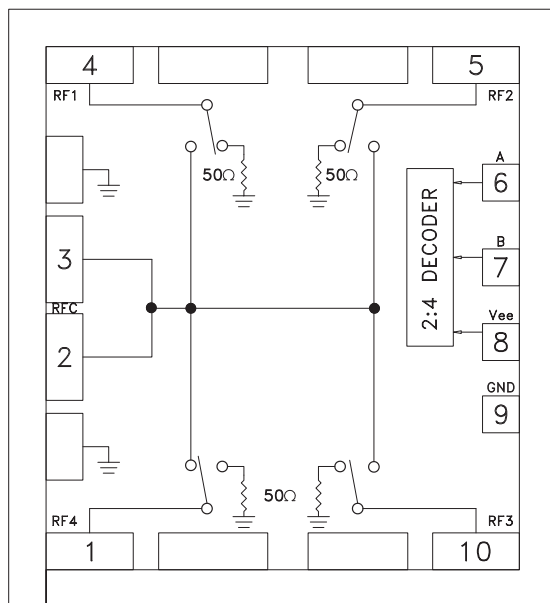

General Description

The HMC344 is a broadband non-reflective GaAs MESFET SP4T switch chip. Covering DC to 8 GHz, this switch offers high isolation, low insertion loss, and a compact form factor. This switch also includes an on board binary decoder circuit which reduces the number of required logic control lines to two. The switch operates using a negative control voltage of 0/-5V, and requires a fixed bias of -5V. All data is tested with the chip in a 50 Ohm test fixture connected via 0.025 mm (1 mil) diameter wire bonds of minimal length 0.31 mm (12 mils). This SP4T switch is also available in SMT packaged form as the HMC344LC3.

Electrical Specifications, $T_A = +25^\circ\text{C}$, With 0/-5V Control, Vee = -5V, 50 Ohm System

Parameter	Frequency	Min.	Typ.	Max.	Units
Insertion Loss	DC - 6.0 GHz		1.8	2.1	dB
	DC - 8.0 GHz		1.9	2.2	dB
Isolation	DC - 2.0 GHz	44	49		dB
	DC - 4.0 GHz	37	42		dB
	DC - 6.0 GHz	34	39		dB
	DC - 8.0 GHz	30	35		dB
Return Loss	"On State"	DC - 2.0 GHz	10	14	dB
		DC - 8.0 GHz	7	10	dB
Return Loss	"Off State"	DC - 8.0 GHz	7	10	dB
Input Power for 1 dB Compression	0.5 - 8.0 GHz	17	21		dBm
Input Third Order Intercept (Two-Tone Input Power = +7 dBm Each Tone)	0.5 - 8.0 GHz	37	40		dBm
Switching Characteristics tRISE, tFALL (10/90% RF) tON, tOFF (50% CTL to 10/90% RF)	DC - 8.0 GHz		35		ns
			150		ns

For price, delivery, and to place orders, please contact Hittite Microwave Corporation:
20 Alpha Road, Chelmsford, MA 01824 Phone: 978-250-3343 Fax: 978-250-3373
Order On-line at www.hittite.com

GaAs MMIC SP4T NON-REFLECTIVE SWITCH, DC - 8 GHz

Insertion Loss vs. Temperature

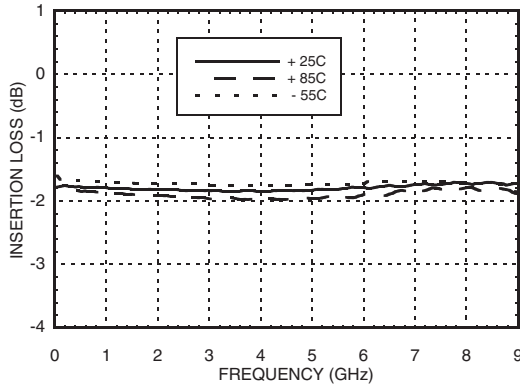

Isolation

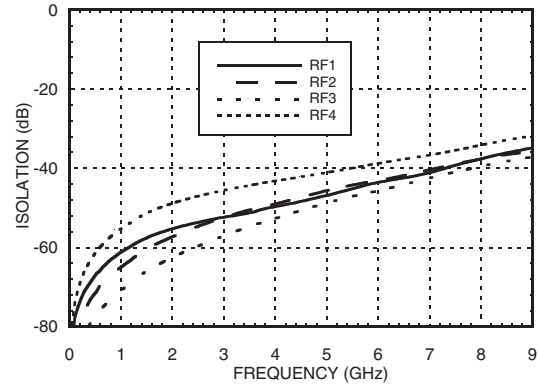

Return Loss

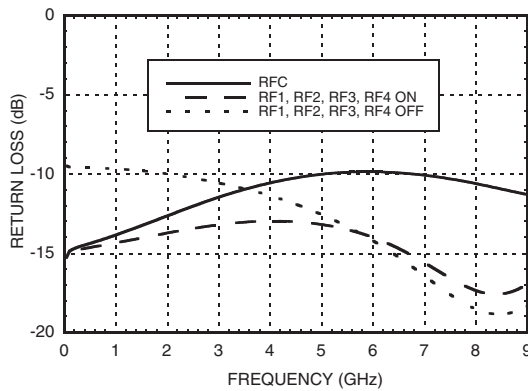

0.1 and 1 dB Input Compression Point

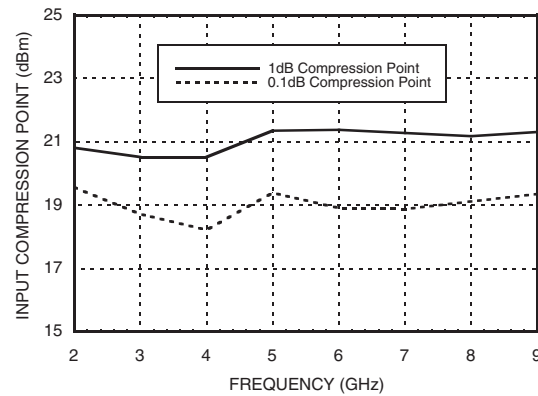

Input Third Order Intercept Point

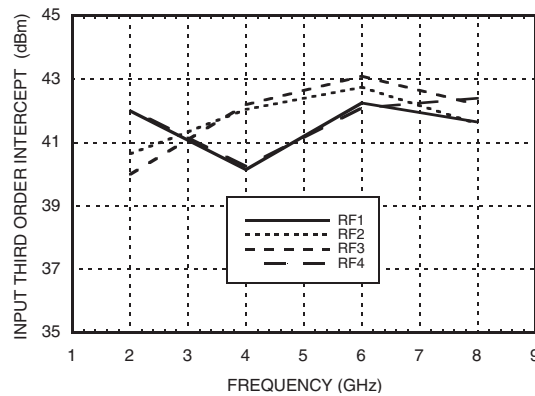

GaAs MMIC SP4T NON-REFLECTIVE SWITCH, DC - 8 GHz

Absolute Maximum Ratings

Bias Voltage Range (Vee)	-7V
Control Voltage Range (A & B)	Vee -0.5V to +1V
Channel Temperature	150 °C
Thermal Resistance (Insertion Loss Path)	143 °C/W
Thermal Resistance (Terminated Path)	1,030 °C/W
Storage Temperature	-65 to +150 °C
Operating Temperature	-55 to +85 °C
Maximum Input Power	+24 dBm
ESD Sensitivity (HBM)	Class 1A

Truth Table

Control Input		Signal Path State
A	B	RF COM to:
High	High	RF1
Low	High	RF2
High	Low	RF3
Low	Low	RF4

Bias Voltage & Current

Vee Range = -5 Vdc ±10%		
Vee (V)	I _{dd} (Typ) (mA)	I _{dd} (Max) (mA)
-5	3	6



ELECTROSTATIC SENSITIVE DEVICE
OBSERVE HANDLING PRECAUTIONS

TTL/CMOS Control Voltages

State	Bias Condition
Low	-3V to 0 Vdc @ 60 uA Typ.
High	-5 to 4.2 Vdc @ 5 uA Typ.

GaAs MMIC SP4T NON-REFLECTIVE SWITCH, DC - 8 GHz

Outline Drawing

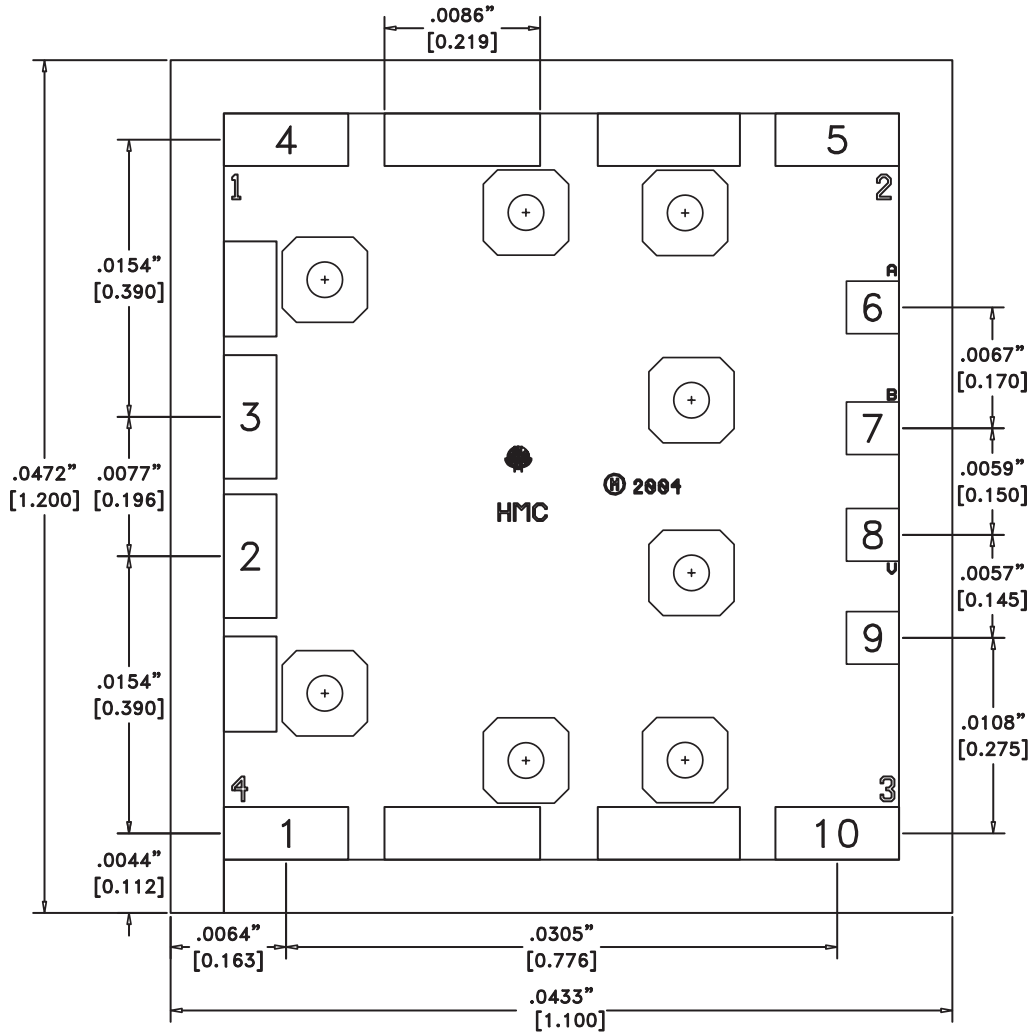

Die Packaging Information [1]

Standard	Alternate
WP-2 (Waffle Pack)	[2]

[1] Refer to the "Packaging Information" section for die packaging dimensions.



[2] For alternate packaging information contact Hittite Microwave Corporation.

NOTES:

1. DIMENSIONS IN INCHES [MILLIMETERS].
2. DIE THICKNESS IS 0.004".
3. TYPICAL BOND PAD IS 0.004" SQUARE.
4. TYPICAL BOND PAD SPACING IS 0.006" CENTER TO CENTER.
5. BOND PAD METALLIZATION: GOLD.
6. BACKSIDE METALLIZATION: GOLD.
7. BACKSIDE METAL IS GROUND.
8. NO CONNECTION REQUIRED FOR UNLABELED BOND PADS.

GaAs MMIC SP4T NON-REFLECTIVE SWITCH, DC - 8 GHz

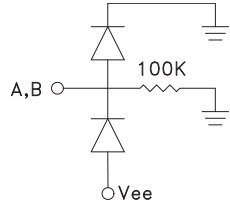
Pad Descriptions

Pad Number	Function	Description	Interface Schematic
1, 2, 3, 4, 5, 10	RF4, RFC, RF1, RF2, RF3	These pads are DC coupled and matched to 50 Ohms. Blocking capacitors are required.	
6	A	See truth table and control voltage table.	
7	B	See truth table and control voltage table.	
8	Vee	Supply Voltage -5.0 Vdc ±10%	
9, Die Bottom	GND	Die bottom and pad must be connected to RF/DC ground.	

TTL Interface Circuit

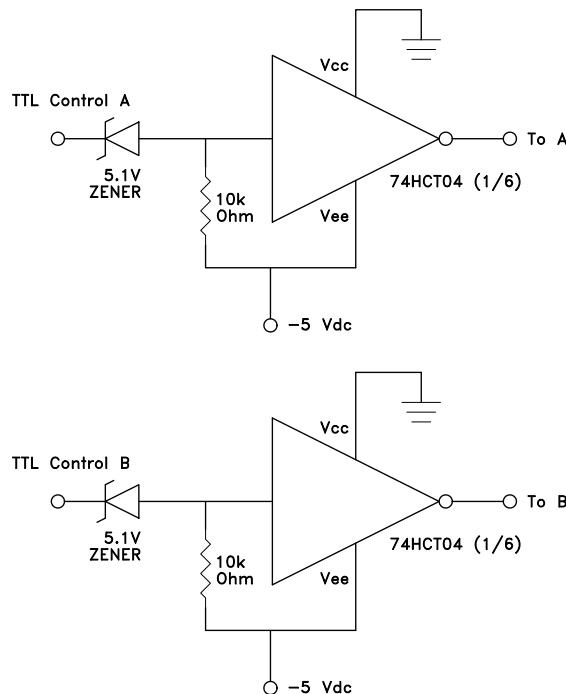

Note:
Control inputs A and B can be driven directly with TTL logic with -5 Volts applied to the HCT logic gates Vee pin and to Vee (pad) of the RF Switch.

GaAs MMIC SP4T NON-REFLECTIVE SWITCH, DC - 8 GHz

Assembly Diagram

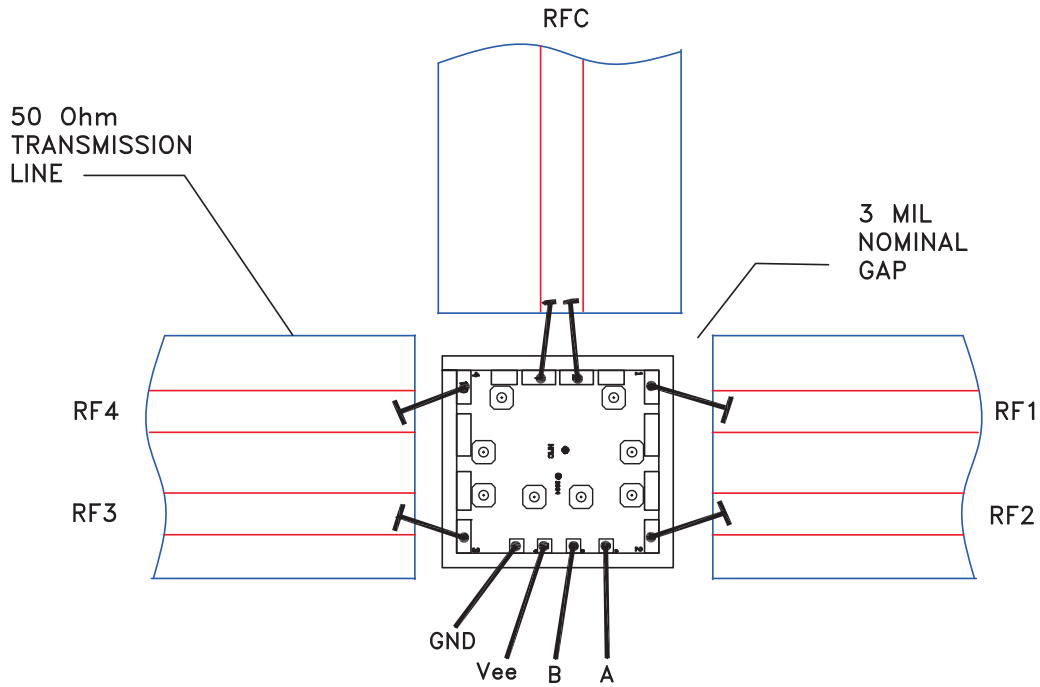



Стандарт Электрон Связь

Мы молодая и активно развивающаяся компания в области поставок электронных компонентов. Мы поставляем электронные компоненты отечественного и импортного производства напрямую от производителей и с крупнейших складов мира.

Благодаря сотрудничеству с мировыми поставщиками мы осуществляем комплексные и плановые поставки широчайшего спектра электронных компонентов.

Собственная эффективная логистика и склад в обеспечивает надежную поставку продукции в точно указанные сроки по всей России.

Мы осуществляем техническую поддержку нашим клиентам и предпродажную проверку качества продукции. На все поставляемые продукты мы предоставляем гарантию .

Осуществляем поставки продукции под контролем ВП МО РФ на предприятия военно-промышленного комплекса России , а также работаем в рамках 275 ФЗ с открытием отдельных счетов в уполномоченном банке. Система менеджмента качества компании соответствует требованиям ГОСТ ISO 9001.

Минимальные сроки поставки, гибкие цены, неограниченный ассортимент и индивидуальный подход к клиентам являются основой для выстраивания долгосрочного и эффективного сотрудничества с предприятиями радиоэлектронной промышленности, предприятиями ВПК и научно-исследовательскими институтами России.

С нами вы становитесь еще успешнее!

Наши контакты:

Телефон: +7 812 627 14 35

Электронная почта: sales@st-electron.ru

Адрес: 198099, Санкт-Петербург,
Промышленная ул, дом № 19, литера Н,
помещение 100-Н Офис 331