



ON Semiconductor®

<http://onsemi.com>

LC709202F

CMOS LSI 1-Cell Li+ (lithium-ion) Battery Monitor IC

Overview

The LC709202F is an IC that measures the remaining power level of 1-cell lithium-ion (Li+) batteries used for a portable equipment etc.

This product is able to reduce a fuel gauge errors by implementing its unique correction technology for measurement value of battery temperature and voltage.

It is possible for this to realize high precision for measurement in battery power measurement IC that does not need a current sensing resistor. ($\pm 3\%$ under certain conditions)

Applications

- Wireless Handsets
- Smartphones/PDA devices
- MP3 players
- digital cameras
- Portable Game Players
- USB-related devices

Features

- Accuracy of remaining battery power level measurement
 - $\pm 3\%$ (at an ambient operating temperature of 0°C to 50°C)
 - Note: The accuracy above is the value of an experiment using the evaluation board.
- Precision $\pm 7.5\text{mV/Cell}$ Voltage Measurement
- A current sensing resistor is unnecessary.
- Alert function
- Interface
 - I²C Interface (up to 400 kHz supported)
- Low power consumption
 - Normal Mode : $15\mu\text{A}$
 - Sleep Mode : $0.1\mu\text{A}$
- Corresponding battery
 - Model to be used depending on the material of the electrode of the battery pack + is different.
 - LC709202F-01: ternary system
 - LC709202F-02: nickelic acid

Package Dimensions

unit : mm (typ)
3318

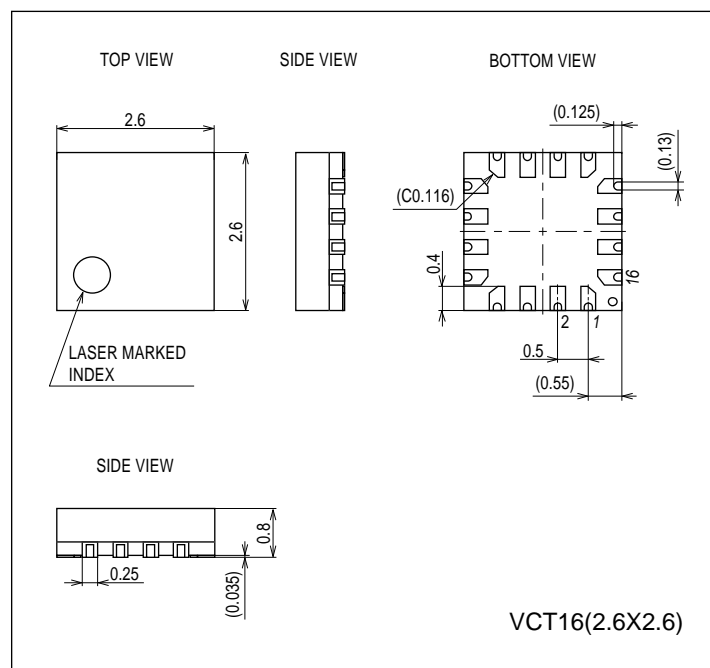

* I²C Bus is a trademark of Philips Corporation.

LC709202F

■ Ports

- I²C communication pin 2 (SDA, SCL)
- Battery temperature reading control pin 1 (TSW)
- Analog voltage input pin for battery temperature 1 (TSENSE)
- External alarm / Interrupt for Low-Battery warning 1 (ALARMB)
- Reset pin 1 (RESB)
- TEST pin 3 (TEST0, TEST1, TEST2)
- Power supply pin 3 (VSS, VDD1, VDD2)

■ Package form

- VCT16 (2.6×2.6) : Lead-free type

Pin Assignment

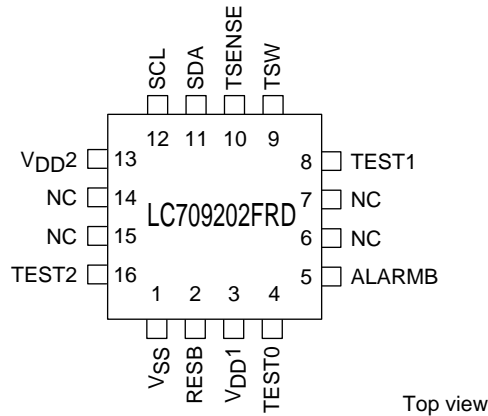

Top view

VCT16 (2.6×2.6) “Lead-free Type”

Pin Function

VCT16	Pin Name	I/O	Description
1	VSS	-	Connect to the - terminal of the battery.
2	RESB	I	Reset pin
3	VDD1	-	Connect to the + terminal of the battery.
4	TEST0	I	Test pin *Connect to VSS.
5	ALARMB	O	Alert indication. An active low output used to indicate specified condition thresholds have been met. *When you do not use an alert function, please connect with VSS.
8	TEST1	O	Set “OPEN”
9	TSW	O	Battery temperature reading control pin *Set high when reading in the temperature, held low at other times.
10	TSENSE	I	Battery temperature analog voltage input pin
11	SDA	I/O	I ² C data pin
12	SCL	I/O	I ² C clock pin
13	VDD2	-	+ power pin for I ² C-Bus communication pin(SDA,SCL)
16	TEST2	O	Set “OPEN”

LC709202F

Block Diagram

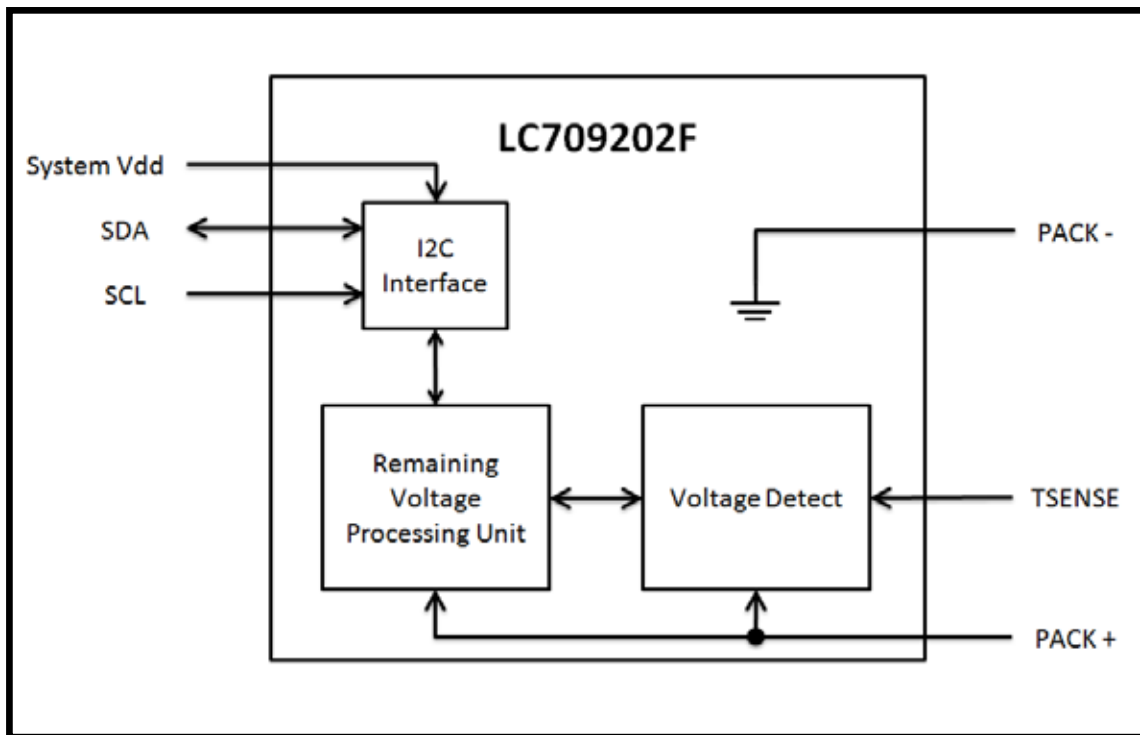

LC709202F

Absolute Maximum Ratings at Ta=25°C, VSS=0V

Parameter	Symbol	Pin/Remarks	Conditions	Specification			Unit	
				VDD[V]	min	typ		max
Maximum supply voltage	VDD max	VDD1, VDD2			-0.3		+6.5	V
Input voltage	VI (1)	RESB, TSENSE			-0.3		VDD1 +0.3	
Output voltage	VO (1)	TSW			-0.3		VDD1 +0.3	
	VO (2)	ALARMB			-0.3			
Input/output voltage	VI/O (1)	SDA, SCL			-0.3		+5.5	
Allowable power dissipation	Pd max	VCT16	Ta=-40 to+85°C				55	mW
Operating ambient temperature	Topr				-40		+85	°C
Storage ambient temperature	Tstg				-55		+125	

Stresses exceeding Maximum Ratings may damage the device. Maximum Ratings are stress ratings only. Functional operation above the Recommended Operating Conditions is not implied. Extended exposure to stresses above the Recommended Operating Conditions may affect device reliability.

Allowable Operating Conditions at Ta= -40 to +85°C, VSS=0V

Parameter	Symbol	Pin/Remarks	Conditions	Specification			unit	
				VDD[V]	min	typ		max
Operating supply voltage	VDD (1)	VDD1			2.5		4.5	V
High level input voltage	VIH (1)	TSENSE		2.5 to 4.5	0.70VDD1		VDD1	
	VIH (2)	RESB		2.5 to 4.5	0.75VDD1		VDD1	
	VIH (3)	SDA, SCL	VDD2=1.6V to 5.5V	2.5 to 4.5	0.70VDD2		VDD2	
Low level input voltage	VIL (1)	TSENSE		2.5 to 4.5	VSS		0.25VDD1	
	VIL (2)	RESB		2.5 to 4.5	VSS		0.25VDD1	
	VIL (3)	SDA, SCL	VDD2=1.6V to 5.5V	2.5 to 4.5	VSS		0.30VDD2	

LC709202F

Electrical Characteristics at Ta= -40 to +85°C, VSS=0V

Parameter	Symbol	Pin/Remarks	Conditions	Specification			Unit	
				V _{DD} [V]	min	typ		max
High level input current	I _{IH} (1)	RESB	V _{IN} =V _{DD1} (including output transistor off leakage current)	2.5 to 4.5			1	μA
	I _{IH} (2)	SDA, SCL	V _{IN} =V _{DD2} V _{DD2} =1.6V to 5.5V (including output transistor off leakage current)	2.5 to 4.5			1	
Low level input current	I _{IL} (1)	RESB	V _{IN} =V _{SS} (including output transistor off leakage current)	2.5 to 4.5	-1			μA
	I _{IL} (2)	SDA, SCL	V _{IN} =V _{SS} V _{DD2} =1.6V to 5.5V (including output transistor off leakage current)	2.5 to 4.5	-1			
High level output voltage	V _{OH} (1)	TSW	I _{OH} =-0.4 mA	3.0 to 4.5	V _{DD} -0.4			V
	V _{OH} (2)		I _{OH} =-0.2 mA	2.5 to 4.5	V _{DD} -0.4			
Low level output voltage	V _{OL} (1)	TSW, ALARMB, SDA, SCL	I _{OL} =3.0 mA	3.0 to 4.5			0.4	V
	V _{OL} (2)		I _{OL} =1.3 mA	2.5 to 4.5			0.4	
Hysteresis voltage	V _{HYS} (1)	RESB		2.5 to 4.5		0.1V _{DD1}		V
	V _{HYS} (2)	SDA, SCL		2.5 to 4.5		0.1V _{DD2}		
Pin capacitance	CP	All pins	Pins other than the pin under test V _{IN} =V _{SS} Ta=25°C	2.5 to 4.5		10		pF
Consumption current (Note 1)	I _{DD} (1)	V _{DD1}	Normal Mode	2.5 to 4.5		15	26	μA
	I _{DD} (2)		Auto Mode	2.5 to 4.5		2 to 15	4 to 26	
	I _{DD} (3)		Sleep Mode	2.5 to 4.5		0.1	5	
Voltage measurement accuracy	V _{ME} (1)	V _{DD1}	Ta= +25°C	3.6	-7.5		+7.5	mV/cell
	V _{ME} (2)		Ta= -20°C to +70°C	2.5 to 4.5	-20		+20	

Note 1: Consumption current is a value in the range of -20°C to +70°C

LC709202F

I²C Slave Characteristics at Ta=-40 to+85°C, VSS=0V

Parameter	Symbol	Pin/Remarks	Conditions	V _{DD} [V]	Specification		unit
					min	max	
Clock frequency	TSCL	SCL		2.5 to 4.5		400	kHz
Bus free time between STOP condition and START condition	TBUF	SCL, SDA	See Fig. 1.		1.3		μs
Hold time (repeated) START condition First clock pulse is generated after this interval	THD:STA	SCL, SDA	See Fig. 1.		0.6		μs
Repeated START condition setup time	TSU:STA	SCL, SDA	See Fig. 1.		0.6		μs
STOP condition setup time	TSU:STO	SCL, SDA	See Fig. 1.		0.6		μs
Data hold time	THD:DAT	SCL, SDA	See Fig. 1.		0	0.9	μs
Data setup time	TSU:DAT	SCL, SDA	See Fig. 1.		100		ns
Clock low period	TLOW	SCL			1.3		μs
Clock high period	THIGH	SCL			0.6		μs
Clock/data fall time	TF	SCL, SDA			20 + 0.1C _B	300	ns
Clock/data rise time	TR	SCL, SDA			20 + 0.1C _B	300	ns

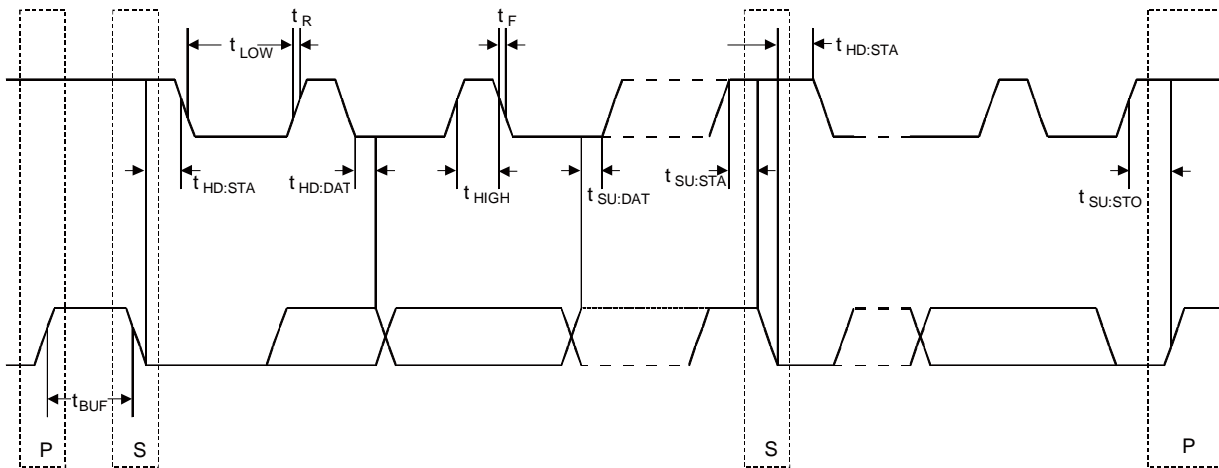

Figure 1 I²C Timing

Discharge Characteristics

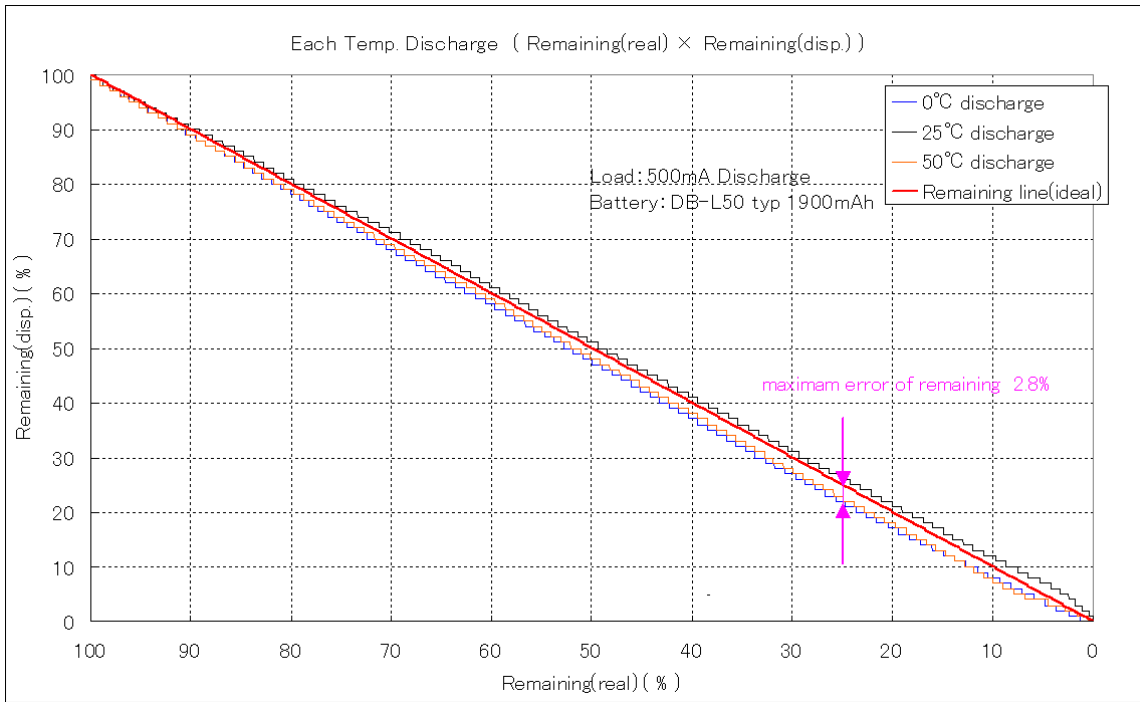

Figure 2 Discharge Characteristics by Temperature Change

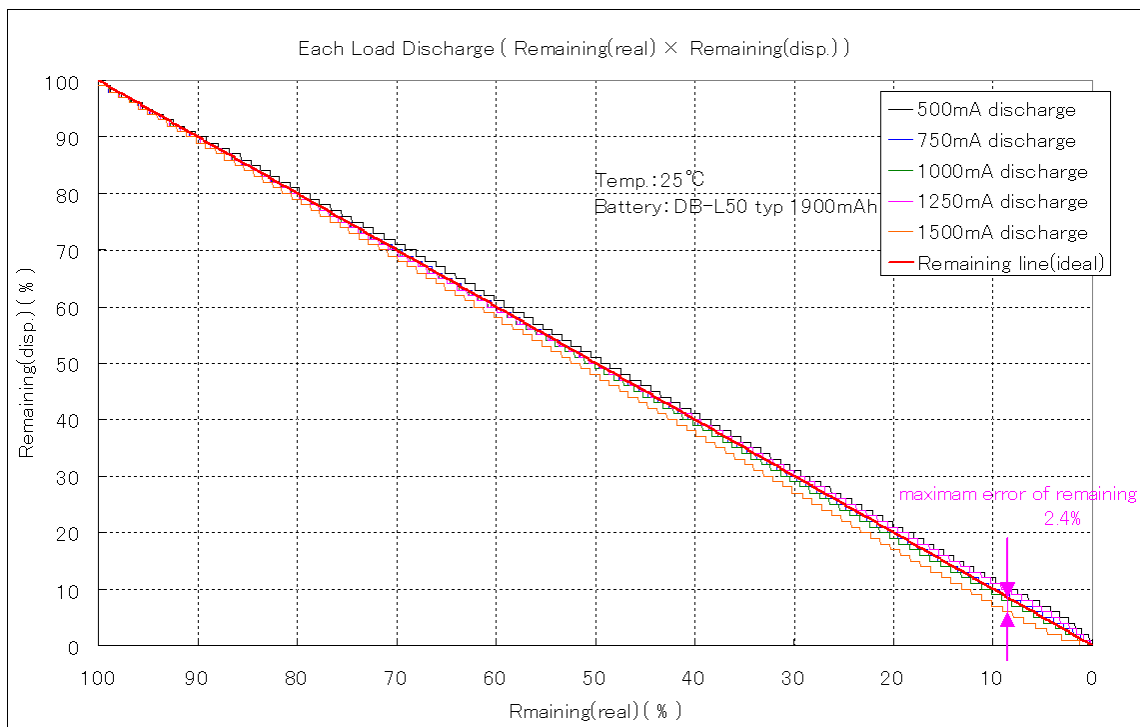

Figure 3 Discharge Characteristics by Load Change

Communication Protocol

Communication protocol type: I²C
 Frequency: 400 kHz
 Address: 0x16

Bus Protocols

- S : Start Condition
- Sr : Repeated Start Condition
- Rd : Read (bit value of 1)
- Wr : Write (bit value of 0)
- A : ACK (bit value of 0)
- N : NACK (bit value of 1)
- P : Stop Condition
- CRC-8 : Slave Address to Last Data (CRC-8-ATM: ex.3778mV: 0x16,0x09,0x17,0xC2,0x0E □ 0x86)
- : Master-to-Slave
- : Slave-to-Master
- ... : Continuation of protocol

Read Word Protocol

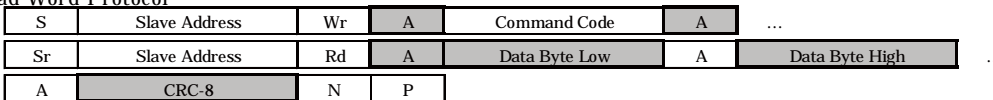

Write Word Protocol

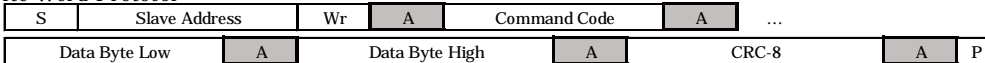

Access	Slave Functions	Command Code	Range	Unit
Read	Cell Temperature	0x08	0 to 65535	0.1°K (0.0°C= 2732)
	Cell Voltage	0x09	0 to 65535	mV
	Current	0x0A	-32768 to 32767	mA
	Adjustment Pack 8	0x0B	0 to 255	Value
	Relative State Of Charge	0x0D	0 to 100	%
	Remaining Capacity	0x0F	0 to 1000	mAh
	Full Charge Capacity	0x10	1000	mAh
	IC Version	0x11	0 to 65535	Version
	Adjustment Thermistor	0x12	0 to 255	Value
	Hot Start ----- Sleep Mode ----- Auto Mode	0x13	bit 0 ----- bit 1 ----- bit 2	disable: 0 or enable: 1
	Alarm Low Battery	0x14	High : 0 to 250 ----- Low : 0 to 100	20mV ----- %
	Adjustment B	0x15	0 to 65535	B
	System Mode	0x16	bit 0to3 : ----- bit 4to7 : data 0 to 6	Normal Mode ----- Sleep Mode ----- Auto Mode ----- Auto deep
	Write	Adjustment Pack 0	0x00	0 to 32767
Adjustment Pack 1		0x01	0 to 32767	Value
Adjustment Pack 2		0x02	0 to 32767	Value
Adjustment Pack 3		0x03	0 to 32767	Value
Adjustment Pack 4		0x04	0 to 32767	Value
Adjustment Pack 5		0x05	0 to 32767	Value
Set Relative State Of Charge		0x08	High : 0xA5 ----- Low : 0 to 100	- ----- %
Adjustment Pack 8			High : 0x5A ----- Low : 0 to 255	- ----- Value
Adjustment Thermistor			High : 0xAA ----- Low : 0 to 255	- ----- Value
Hot Start ----- Sleep Mode ----- Auto Mode			High : ----- Low : 0x55	bit 0 ----- bit 1 ----- bit 2 ----- disable: 0 or enable: 1
Initial Relative State Of Charge		0x09	0xAA55	-
Alarm Low Battery		0x0A	High : 0 to 250 ----- Low : 0 to 100	20mV(activate under) ----- %(activate under)
Adjustment B		0x0B	0 to 65535	B
Cell Temperature		0x0C	2532 to 3332 (I2C Write Mode) ----- 0xAA55 (Thermistor Mode)	0.1°K (0.0°C= 2732) ----- -

LC709202F

Application Circuit Example

Figure 4 Example of an application schematic using LC709202F
(not use temperature detection function)

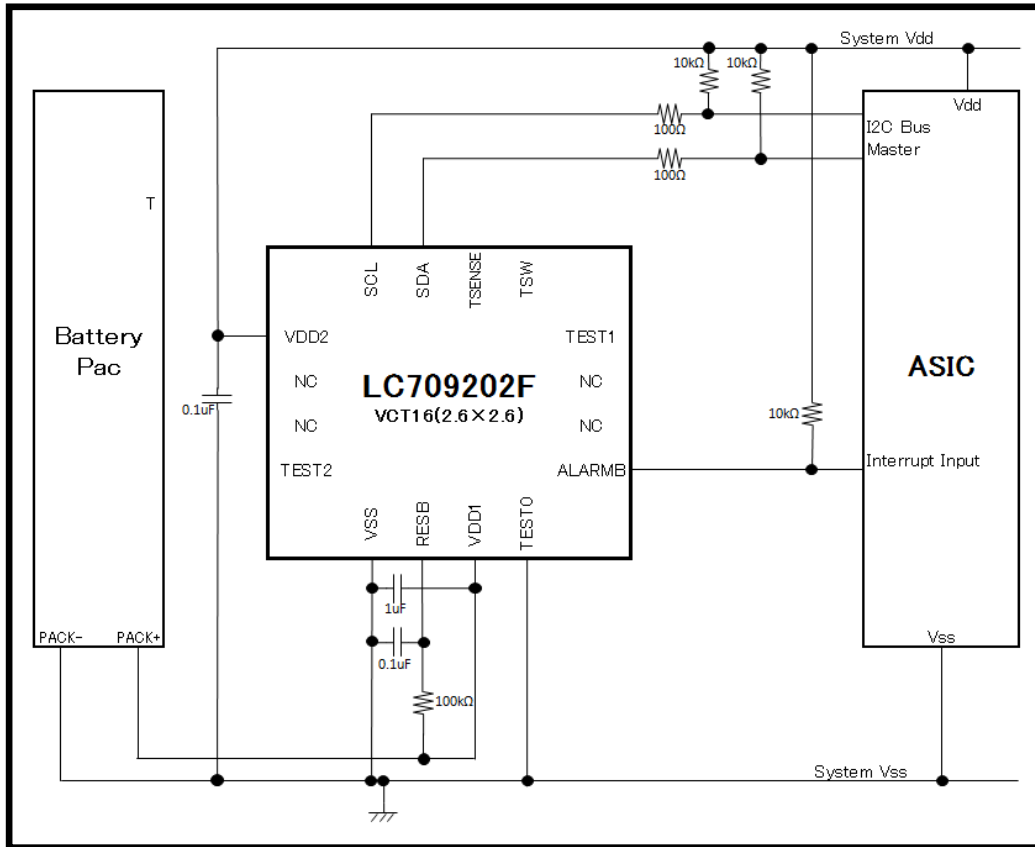
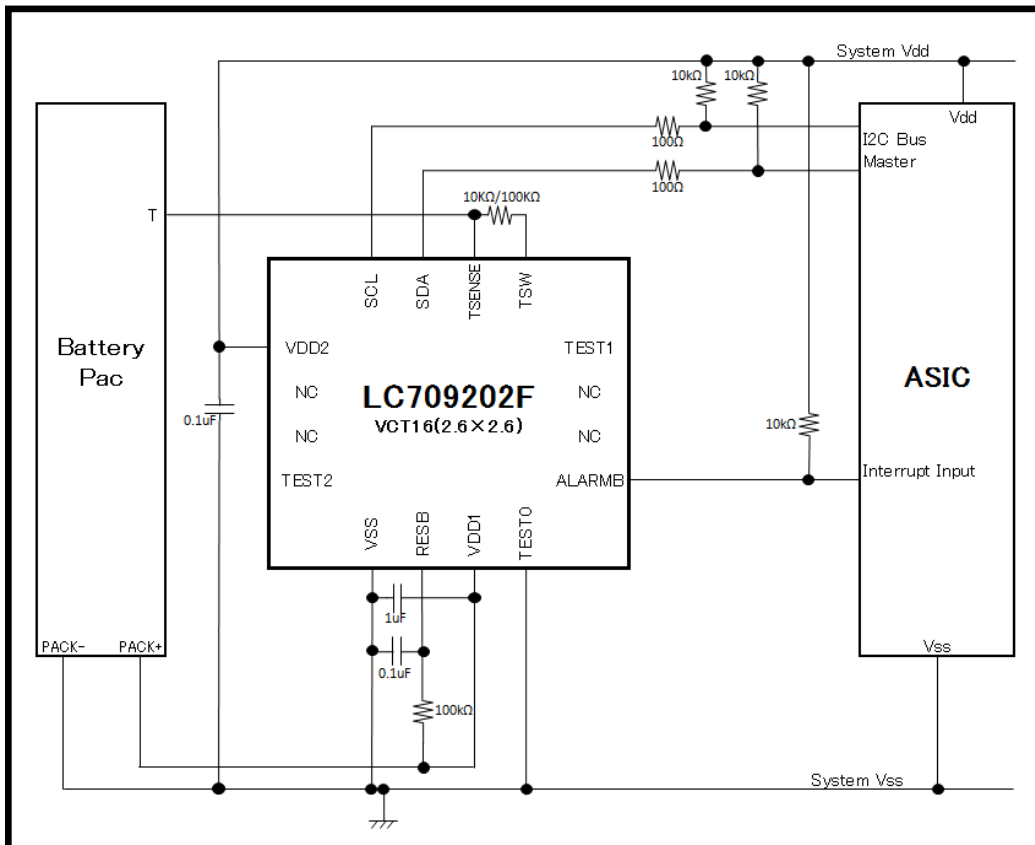

Figure 5 Example of an application schematic using LC709202F
(use temperature detection function)



ON Semiconductor and the ON logo are registered trademarks of Semiconductor Components Industries, LLC (SCILLC). SCILLC owns the rights to a number of patents, trademarks, copyrights, trade secrets, and other intellectual property. A listing of SCILLC's product/patent coverage may be accessed at www.onsemi.com/site/pdf/Patent-Marking.pdf. SCILLC reserves the right to make changes without further notice to any products herein. SCILLC makes no warranty, representation or guarantee regarding the suitability of its products for any particular purpose, nor does SCILLC assume any liability arising out of the application or use of any product or circuit, and specifically disclaims any and all liability, including without limitation special, consequential or incidental damages. "Typical" parameters which may be provided in SCILLC data sheets and/or specifications can and do vary in different applications and actual performance may vary over time. All operating parameters, including "Typicals" must be validated for each customer application by customer's technical experts. SCILLC does not convey any license under its patent rights nor the rights of others. SCILLC products are not designed, intended, or authorized for use as components in systems intended for surgical implant into the body, or other applications intended to support or sustain life, or for any other application in which the failure of the SCILLC product could create a situation where personal injury or death may occur. Should Buyer purchase or use SCILLC products for any such unintended or unauthorized application, Buyer shall indemnify and hold SCILLC and its officers, employees, subsidiaries, affiliates, and distributors harmless against all claims, costs, damages, and expenses, and reasonable attorney fees arising out of, directly or indirectly, any claim of personal injury or death associated with such unintended or unauthorized use, even if such claim alleges that SCILLC was negligent regarding the design or manufacture of the part. SCILLC is an Equal Opportunity/Affirmative Action Employer. This literature is subject to all applicable copyright laws and is not for resale in any manner.



Стандарт Электрон Связь

Мы молодая и активно развивающаяся компания в области поставок электронных компонентов. Мы поставляем электронные компоненты отечественного и импортного производства напрямую от производителей и с крупнейших складов мира.

Благодаря сотрудничеству с мировыми поставщиками мы осуществляем комплексные и плановые поставки широчайшего спектра электронных компонентов.

Собственная эффективная логистика и склад в обеспечивает надежную поставку продукции в точно указанные сроки по всей России.

Мы осуществляем техническую поддержку нашим клиентам и предпродажную проверку качества продукции. На все поставляемые продукты мы предоставляем гарантию .

Осуществляем поставки продукции под контролем ВП МО РФ на предприятия военно-промышленного комплекса России , а также работаем в рамках 275 ФЗ с открытием отдельных счетов в уполномоченном банке. Система менеджмента качества компании соответствует требованиям ГОСТ ISO 9001.

Минимальные сроки поставки, гибкие цены, неограниченный ассортимент и индивидуальный подход к клиентам являются основой для выстраивания долгосрочного и эффективного сотрудничества с предприятиями радиоэлектронной промышленности, предприятиями ВПК и научно-исследовательскими институтами России.

С нами вы становитесь еще успешнее!

Наши контакты:

Телефон: +7 812 627 14 35

Электронная почта: sales@st-electron.ru

Адрес: 198099, Санкт-Петербург,
Промышленная ул, дом № 19, литера Н,
помещение 100-Н Офис 331