

Future Technology Devices International Ltd

Datasheet Chipi-X Cable



Chipi-X is a USB to full-handshake RS232 cable with a male DB9 connector. This cable is available with or without an enclosure.

1 Introduction

The Chipi-X cable is a USB to RS232 level full-handshake UART cable. Chipi-X utilises FTDI's [FT231XS](#) USB to full-handshake UART IC and FT3243S RS232 transceiver IC. A male DB9 (aka DE9) connector provides the connectivity for RS232 communications and a USB-A plug tethered by a 10cm cable to the PCB provides connectivity for USB communications.

All components used are Pb-free (RoHS compliant).

1.1 Features

- Entire USB protocol handled on the FT232XS chip
- FTDI's royalty-free VCP and D2XX drivers eliminate the requirement for USB driver development in most cases
- UART interface support for 7 or 8 data bits, 1 or 2 stop bits and odd / even / mark / space / no parity.
- Fully assisted hardware or X-On / X-Off software handshaking.
- Data transfer rates from 300 baud to 250 kilo-baud at RS232 voltage levels.
- 512 byte receive buffer and 512 byte transmit buffer utilising buffer smoothing technology to allow for high data throughput
- Adjustable receive buffer timeout.
- ESD protection on RS232 I/Os exceeding $\pm 15\text{kV}$ IEC1000-4-2 Air Gap Discharge, $\pm 15\text{kV}$ for Human Body Mode (HBM) and $\pm 8\text{kV}$ IEC1000-4-2 Contact Discharge.
- ESD protection on USB lines exceeding $\pm 2\text{kV}$ for Human Body Mode (HBM), $\pm 200\text{V}$ for Machine Mode (MM) and $\pm 500\text{V}$ for Charged Device Mode (CDM).
- Integrated MTP-ROM for storing USB VID, PID, serial number and product description strings.
- Low operating and USB suspend current.
- Low USB bandwidth consumption.
- USB 2.0 Full Speed compatible.
- -40°C to 85°C extended operating temperature range.
- Latch-up Free



Table of Contents

1	Introduction	1
1.1	Features.....	1
2	Driver Support.....	3
3	Ordering Information	3
4	Functional Description.....	4
4.1	Block Diagram	4
4.2	Electrical Details	4
5	Chipi-X Signals and Pin Out	5
5.1	RS232 Signals	5
5.2	USB Signals.....	5
6	Module Dimensions	6
7	Chipi-X Circuit Schematic	7
8	Internal MTP ROM Configuration	8
9	Contact Information	9
	Appendix A – List of Tables and Figures	10
	Appendix B – Revision History	11

2 Driver Support

Royalty-Free VIRTUAL COM PORT (VCP) DRIVERS for:

- Windows 7 32,64-bit
- Windows Vista
- Windows XP 32,64-bit
- Windows XP Embedded
- Windows CE.NET 4.2 , 5.0 and 6.0
- MAC OS OS-X
- Linux 2.6.32 or later Android

Royalty-Free D2XX Direct Drivers (USB Drivers + DLL S/W Interface):

- Windows 7 32,64-bit
- Windows Vista
- Windows XP 32,64-bit
- Windows XP Embedded
- Windows CE.NET 4.2, 5.0 and 6.0
- MAC OS OS-X
- Linux 2.6.32 or later Android

The drivers listed above are all available to download for free from www.ftdichip.com. Various 3rd Party Drivers are also available for various other operating systems - visit www.ftdichip.com for details.

For driver installation instructions please see:
<http://www.ftdichip.com/Support/Documents/InstallGuides.htm>.

3 Ordering Information

Part Number	Description
Chipi-X	Generic part number, no part assigned to this part number.
CHIPI-X10	USB to RS232 converter with a 10cm cable and an enclosure. FCC and CE approved.
CHIPI-X-NE10	USB to RS232 converter with a 10cm cable and no enclosure .

Table 3.1 – Chipi-X Ordering Information

4 Functional Description

4.1 Block Diagram

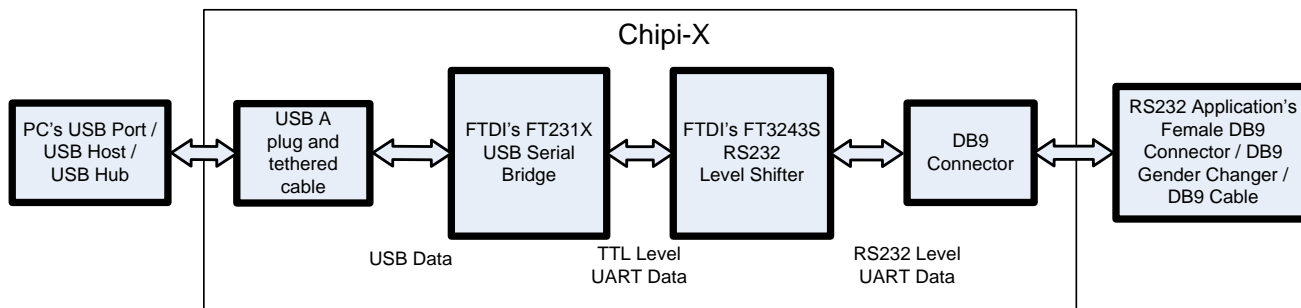

Figure 4.1 – Chipi-X Block Diagram

4.2 Electrical Details

Parameter	Description	Minimum	Typical	Maximum	Units	Conditions
Vtrans	Transmitter output voltage swing	+/- 5	+/- 6.5	+/- 15	V	
Vrec	Receiver input voltage range	-25		+25	V	

Table 4.1 – Chipi-X I/O Characteristics

Description	Conditions	Minimum	Typical	Maximum
ESD HBM	RS-232 Inputs and Outputs		±15 kV	
EN61000-4-2ContactDischarge	RS-232 Inputs and Outputs		±8 kV	
EN61000-4-2AirGapDischarge	RS-232 Inputs and Outputs		±15 kV	

Table 4.2 – Chipi-X ESD Tolerance

5 Chipi-X Signals and Pin Out

5.1 RS232 Signals

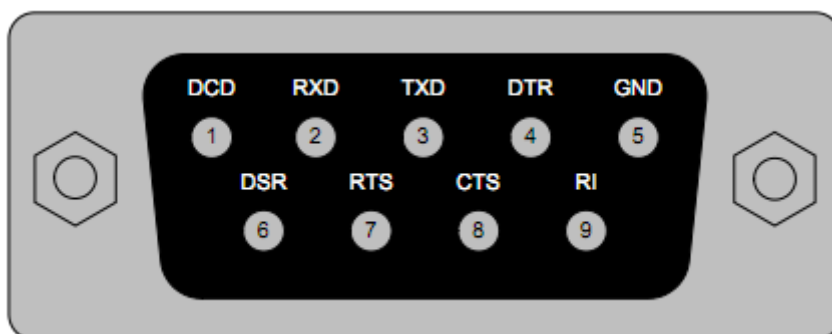

Figure 5.1 – Chipi-X DB9 Pin Out

DB9 pin No.	Name	Type	Description
1	DCD	Input	Data Carrier Detect control input.
2	RXD	Input	Receive Asynchronous Data input.
3	TXD	Output	Transmit Asynchronous Data output.
4	DTR	Output	Handshake signal: Data Terminal Ready control output.
5	GND	Ground	Device ground supply pin
6	DSR	Input	Handshake signal: Data Set Ready control input
7	RTS	Output	Handshake signal: Request To Send Control Output
8	CTS	Input	Handshake signal: Clear to Send Control input
9	RI	Input	Ring Indicator control input. When remote wakeup is enabled in the FT231XS's internal MTP-ROM taking RI# low can be used to resume the PC USB host controller from suspend.

Table 5.1 – Chipi-X RS232 Signals

5.2 USB Signals

Wire Colour.	Name	Type	Description
Red	VBUS	Power	5V power.
White	DM	Signal	USB data.
Green	DP	Signal	USB data.
Black	GND	Ground	Ground.
Black (longer wire)	Shield	Shield	Cable shield

Table 5.2 – Chipi-X USB Lines

6 Module Dimensions

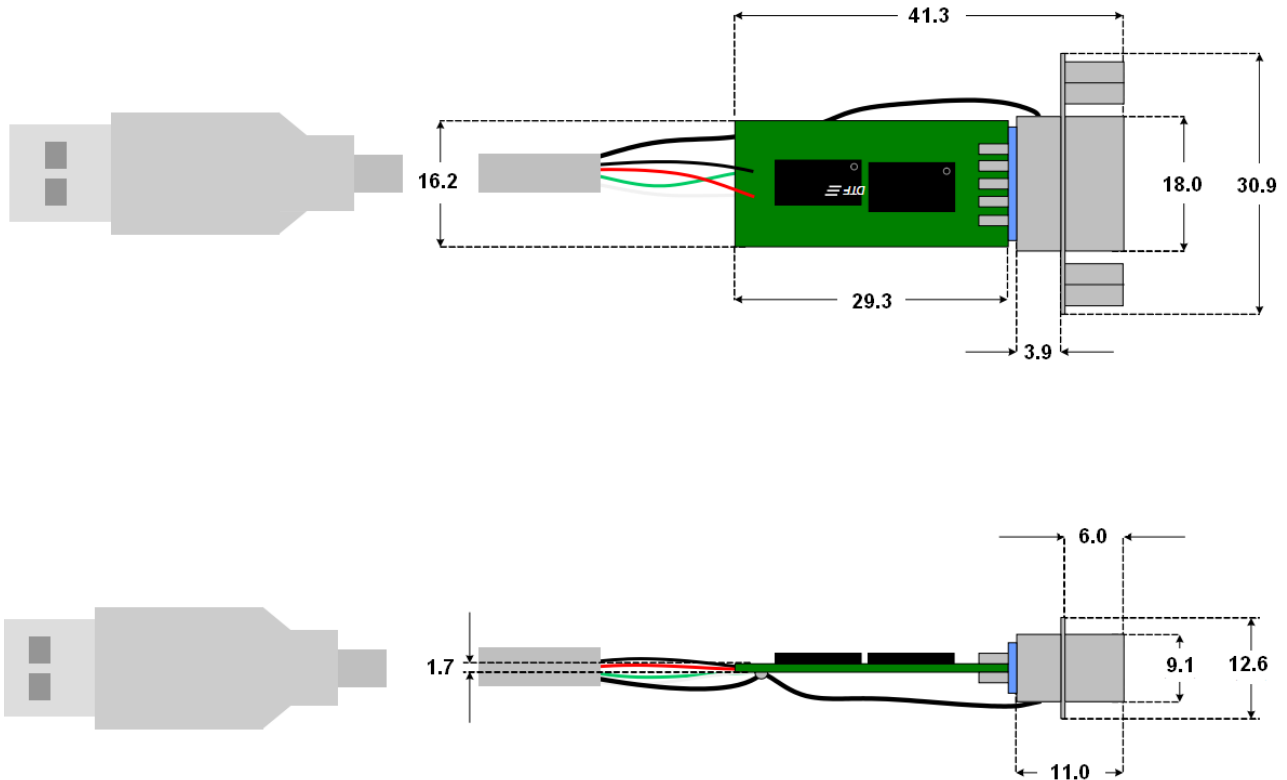

Figure 6.1 – Chipi-X Dimensions

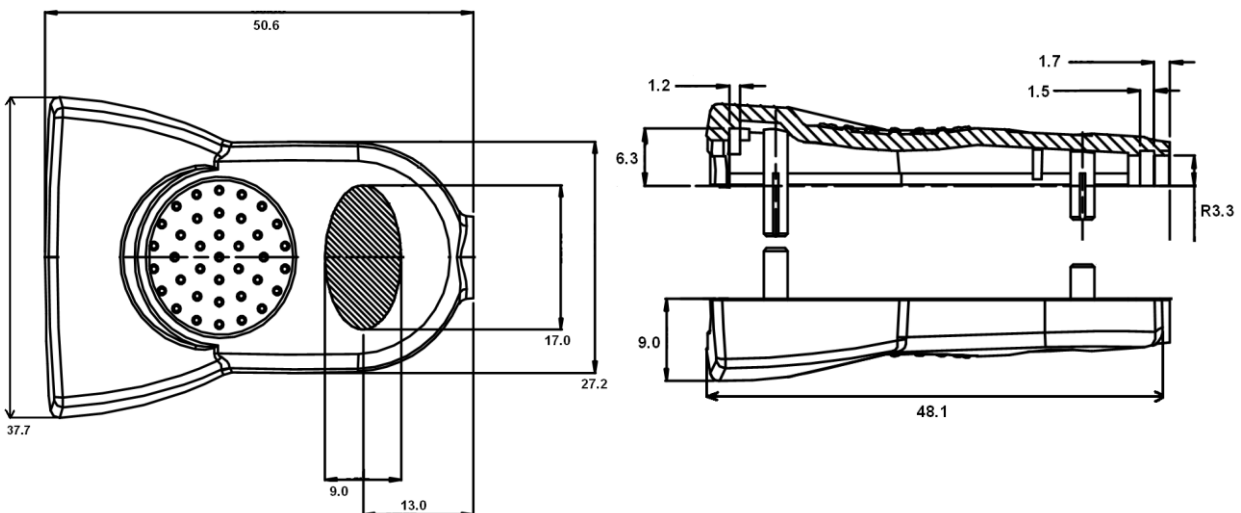

Figure 6.2 – Enclosure Dimensions

All dimensions are given in millimetres.

Chipi-X cables only use lead free components, and are fully compliant with European Union directive 2002/95/EC.

7 Chipi-X Circuit Schematic

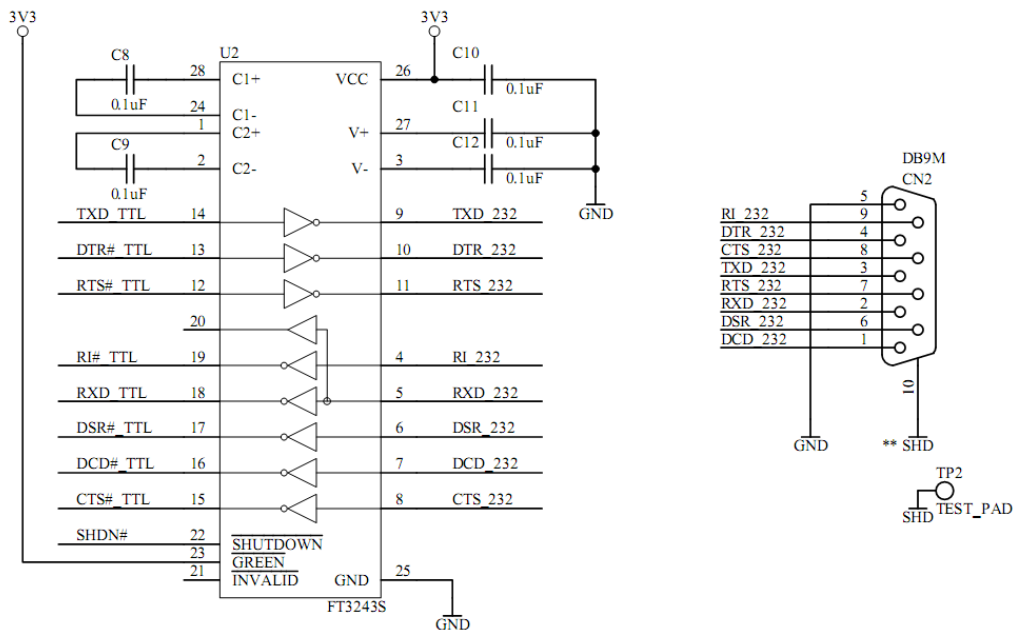
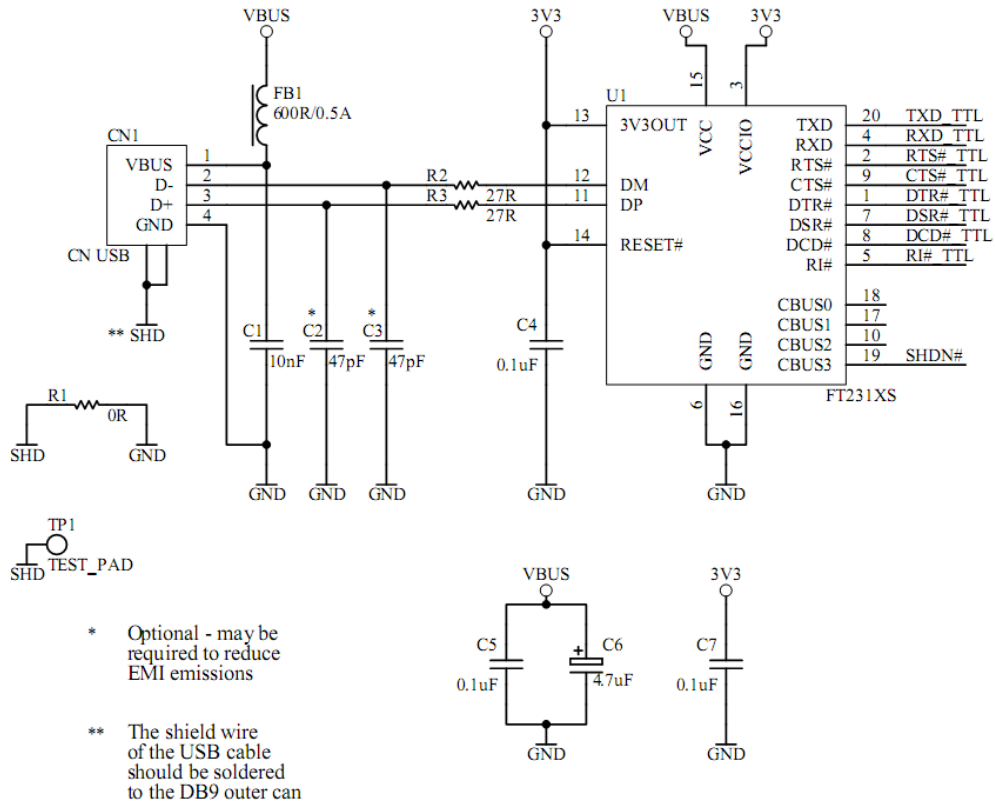

Figure 7.1 – Chipi-X Circuit Schematic

8 Internal MTP ROM Configuration

Following a power-on reset or a USB reset the FT231X will scan its internal MTP ROM and read the USB configuration descriptors stored there. The default values programmed into the internal MTP ROM in the FT231XS used on the Chipi-X are shown in Table 8.1.

Parameter	Value	Notes
USB Vendor ID (VID)	0403h	FTDI default VID (hex)
USB Product UD (PID)	6015h	FTDI default PID (hex)
Serial Number Enabled?	Yes	
Serial Number	See Note	A unique serial number is generated and programmed into the MTP ROM during final test of the UM232R module.
Pull down I/O Pins in USB Suspend	Disabled	Enabling this option will make the device pull down on the UART interface lines when the power is shut off (PWREN# is high).
Manufacturer Name	FTDI	
Product Description	Chipi-X	
Max Bus Power Current	90mA	
Power Source	Bus Powered	
Device Type	FT231X	
USB Version	0200	Returns USB 2.0 device description to the host. Note: The device is a USB 2.0 Full Speed device (12Mb/s) as opposed to a USB 2.0 High Speed device (480Mb/s).
Remote Wake Up	Enabled	Taking RI# low will wake up the USB host controller from suspend.
High Current I/Os	Disabled	Enables the high drive level on the UART and CBUS I/O pins.
Load VCP Driver	Enabled	Makes the device load the VCP driver interface for the device.
CBUS0	Tristate	
CBUS1	Tristate	
CBUS2	Tristate	
CBUS3	SLEEP#	
Invert UART	Disabled	Signal on this pin becomes TXD# if enable.

Table 8.1 – Default Internal MTP ROM Configuration

The internal MTP ROM in the FT231X can be programmed over USB using the utility program FT_PROG. FT_PROG can be downloaded from www.ftdichip.com. Users who do not have their own USB vendor ID but who would like to use a unique Product ID in their design can apply to FTDI for a free block of unique PIDs. Contact [FTDI Support](mailto:support1@ftdichip.com) (support1@ftdichip.com) for this service, also see [TN_100](#) and [TN_101](#).

9 Contact Information

Head Office – Glasgow, UK

Future Technology Devices International Limited
Unit 1, 2 Seaward Place, Centurion Business Park
Glasgow G41 1HH
United Kingdom
Tel: +44 (0) 141 429 2777
Fax: +44 (0) 141 429 2758

E-mail (Sales) sales1@ftdichip.com
E-mail (Support) support1@ftdichip.com
E-mail (General Enquiries) admin1@ftdichip.com

Branch Office – Hillsboro, Oregon, USA

Future Technology Devices International Limited (USA)
7235 NW Evergreen Parkway, Suite 600
Hillsboro, OR 97123-5803
USA
Tel: +1 (503) 547 0988
Fax: +1 (503) 547 0987

E-Mail (Sales) us.sales@ftdichip.com
E-Mail (Support) us.support@ftdichip.com
E-Mail (General Enquiries) us.admin@ftdichip.com

Branch Office – Taipei, Taiwan

Future Technology Devices International Limited (Taiwan)
2F, No. 516, Sec. 1, NeiHu Road
Taipei 114
Taiwan, R.O.C.
Tel: +886 (0) 2 8791 3570
Fax: +886 (0) 2 8791 3576

E-mail (Sales) tw.sales1@ftdichip.com
E-mail (Support) tw.support1@ftdichip.com
E-mail (General Enquiries) tw.admin1@ftdichip.com

Branch Office – Shanghai, China

Future Technology Devices International Limited (China)
Room 408, 317 Xianxia Road,
Shanghai, 200051
China
Tel: +86 21 62351596
Fax: +86 21 62351595

E-mail (Sales) cn.sales@ftdichip.com
E-mail (Support) cn.support@ftdichip.com
E-mail (General Enquiries) cn.admin@ftdichip.com

Web Site

<http://ftdichip.com>

Distributor and Sales Representatives

Please visit the Sales Network page of the [FTDI Web site](#) for the contact details of our distributor(s) and sales representative(s) in your country.

System and equipment manufacturers and designers are responsible to ensure that their systems, and any Future Technology Devices International Ltd (FTDI) devices incorporated in their systems, meet all applicable safety, regulatory and system-level performance requirements. All application-related information in this document (including application descriptions, suggested FTDI devices and other materials) is provided for reference only. While FTDI has taken care to assure it is accurate, this information is subject to customer confirmation, and FTDI disclaims all liability for system designs and for any applications assistance provided by FTDI. Use of FTDI devices in life support and/or safety applications is entirely at the user's risk, and the user agrees to defend, indemnify and hold harmless FTDI from any and all damages, claims, suits or expense resulting from such use. This document is subject to change without notice. No freedom to use patents or other intellectual property rights is implied by the publication of this document. Neither the whole nor any part of the information contained in, or the product described in this document, may be adapted or reproduced in any material or electronic form without the prior written consent of the copyright holder. Future Technology Devices International Ltd, Unit 1, 2 Seaward Place, Centurion Business Park, Glasgow G41 1HH, United Kingdom. Scotland Registered Company Number: SC136640

Appendix A – List of Tables and Figures

List of Figures

Figure 4.1 – Chipi-X Block Diagram.....	4
Figure 5.1 – Chipi-X DB9 Pin Out.....	5
Figure 6.1 – Chipi-X Dimensions.....	6
Figure 6.2 – Enclosure Dimensions.....	6
Figure 7.1 – Chipi-X Circuit Schematic.....	7

List of Tables

Table 3.1 – Chipi-X Ordering Information.....	3
Table 4.1 – Chipi-X I/O Characteristics.....	4
Table 4.2 – Chipi-X ESD Tolerance.....	4
Table 5.1 – Chipi-X RS232 Signals.....	5
Table 5.2 – Chipi-X USB Lines.....	5
Table 8.1 – Default Internal MTP ROM Configuration.....	8

Appendix B – Revision History

Document Title: DS_CHIPI-X
Document Reference No.: FT_000634
Clearance No.: FTDI# 288
Product Page: <http://www.ftdichip.com/FT-X.htm>
Document Feedback: [Send Feedback](#)

Version 1.0 Initial Datasheet Released 14/03/12



Стандарт Электрон Связь

Мы молодая и активно развивающаяся компания в области поставок электронных компонентов. Мы поставляем электронные компоненты отечественного и импортного производства напрямую от производителей и с крупнейших складов мира.

Благодаря сотрудничеству с мировыми поставщиками мы осуществляем комплексные и плановые поставки широчайшего спектра электронных компонентов.

Собственная эффективная логистика и склад в обеспечивает надежную поставку продукции в точно указанные сроки по всей России.

Мы осуществляем техническую поддержку нашим клиентам и предпродажную проверку качества продукции. На все поставляемые продукты мы предоставляем гарантию .

Осуществляем поставки продукции под контролем ВП МО РФ на предприятия военно-промышленного комплекса России , а также работаем в рамках 275 ФЗ с открытием отдельных счетов в уполномоченном банке. Система менеджмента качества компании соответствует требованиям ГОСТ ISO 9001.

Минимальные сроки поставки, гибкие цены, неограниченный ассортимент и индивидуальный подход к клиентам являются основой для выстраивания долгосрочного и эффективного сотрудничества с предприятиями радиоэлектронной промышленности, предприятиями ВПК и научно-исследовательскими институтами России.

С нами вы становитесь еще успешнее!

Наши контакты:

Телефон: +7 812 627 14 35

Электронная почта: sales@st-electron.ru

Адрес: 198099, Санкт-Петербург,
Промышленная ул, дом № 19, литера Н,
помещение 100-Н Офис 331