

USB 2.0 High-Speed 4-Port Hub Controller

PRODUCT FEATURES

Datasheet

General Description

The SMSC 4-Port Hub is low power, OEM configurable, MTT (multi transaction translator) hub controller IC with 4 downstream ports for embedded USB solutions. The 4-port hub is fully compliant with the USB 2.0 Specification and will attach to an upstream port as a Full-Speed Hub or as a Full-/High-Speed Hub. The 4-Port Hub supports Low-Speed, Full-Speed, and High-Speed (if operating as a High-Speed Hub) downstream devices on all of the enabled downstream ports.

General Features

- Hub Controller IC with 4 downstream ports
- High-performance multiple transaction translator MultiTRAK™ Technology Provides one transaction translator per port
- Enhanced OEM configuration options available through either a single serial i2C EEPROM, or SMBus Slave Port
- 36-pin (6x6mm) and 48-Pin (7x7mm) QFN lead-free, RoHS compliant packages
- Footprint compatible with USB2513 and USB2512 (36-pin QFN) to provide designers with flexibility regarding the quantity of USB expansion ports utilized without redesign

Hardware Features

- Low power operation
- Full Power Management with individual or ganged power control of each downstream port
- On-chip Power On Reset (POR)
- Internal 1.8V Voltage Regulator
- Fully integrated USB termination and Pull-up/Pull-down resistors
- On Board 24MHz Crystal Driver, Resonator or External 24/48MHz clock input
- USB host/device speed indicator. Per-port 3-color LED drivers that indicate the speed of USB host and device connection - hi-speed (480 Mbps), full-speed (12 Mbps), low-speed (1.5 Mbps) (48-pin QFN)
- Enhanced EMI rejection and ESD protection performance

OEM Selectable Features

- Customize Vendor ID, Product ID, and Device ID
- Select whether the hub is part of a compound device (When any downstream port is permanently hardwired to a USB peripheral device, the hub is part of a compound device)

- Flexible port mapping and disable sequence. Ports can be disabled/reordered in any order to support multiple product SKUs. Hub will automatically reorder the remaining ports to match the Host controller's numbering scheme
- Programmable USB differential-pair pin location
- Ease PCB layout by aligning USB signal lines directly to connectors
- Programmable USB signal drive strength. Recover USB signal integrity due to compromised system environment using 4-level driving strength resolution
- Select the presence of a permanently hardwired USB peripheral device on a port by port basis
- Configure the delay time for filtering the over-current sense inputs
- Configure the delay time for turning on downstream port power
- Configure the polarity of downstream port power control signals
- Indicate the maximum current that the 4-port hub consumes from the USB upstream port
- Indicate the maximum current required for the hub controller
- Supports Custom String Descriptor up to 31 characters in length for:
 - Product String
 - Manufacturer String
 - Serial Number String
- Pin Selectable Options for Default Configuration
 - Select Downstream Ports as Non-Removable Ports
 - Select Downstream Ports as Disabled Ports
 - Select Downstream Port Power Control and Over-Current Detection on a Ganged or Individual Basis
 - Select Downstream Port Power Control Polarity
 - Select USB Signal Drive Strength
 - Select USB Differential Pair Pin location
 - Select on-chip or off-chip voltage regulator mode

Applications

- LCD monitors and TVs
- Multi-function USB peripherals
- PC mother boards
- Set-top boxes, DVD players, DVR/PVR
- Printers and scanners
- PC media drive bay
- Portable hub boxes
- Mobile PC docking
- Embedded systems

ORDER NUMBERS:**USB2514-AEZG FOR 36 PIN, QFN LEAD-FREE ROHS COMPLIANT PACKAGE****USB2514-HZH FOR 48 PIN, QFN LEAD-FREE ROHS COMPLIANT PACKAGE**

80 ARKAY DRIVE, HAUPPAUGE, NY 11788 (631) 435-6000, FAX (631) 273-3123

Copyright © 2007 SMSC or its subsidiaries. All rights reserved.

Circuit diagrams and other information relating to SMSC products are included as a means of illustrating typical applications. Consequently, complete information sufficient for construction purposes is not necessarily given. Although the information has been checked and is believed to be accurate, no responsibility is assumed for inaccuracies. SMSC reserves the right to make changes to specifications and product descriptions at any time without notice. Contact your local SMSC sales office to obtain the latest specifications before placing your product order. The provision of this information does not convey to the purchaser of the described semiconductor devices any licenses under any patent rights or other intellectual property rights of SMSC or others. All sales are expressly conditional on your agreement to the terms and conditions of the most recently dated version of SMSC's standard Terms of Sale Agreement dated before the date of your order (the "Terms of Sale Agreement"). The product may contain design defects or errors known as anomalies which may cause the product's functions to deviate from published specifications. Anomaly sheets are available upon request. SMSC products are not designed, intended, authorized or warranted for use in any life support or other application where product failure could cause or contribute to personal injury or severe property damage. Any and all such uses without prior written approval of an Officer of SMSC and further testing and/or modification will be fully at the risk of the customer. Copies of this document or other SMSC literature, as well as the Terms of Sale Agreement, may be obtained by visiting SMSC's website at <http://www.smisc.com>. SMSC is a registered trademark of Standard Microsystems Corporation ("SMSC"). Product names and company names are the trademarks of their respective holders.

SMSC DISCLAIMS AND EXCLUDES ANY AND ALL WARRANTIES, INCLUDING WITHOUT LIMITATION ANY AND ALL IMPLIED WARRANTIES OF MERCHANTABILITY, FITNESS FOR A PARTICULAR PURPOSE, TITLE, AND AGAINST INFRINGEMENT AND THE LIKE, AND ANY AND ALL WARRANTIES ARISING FROM ANY COURSE OF DEALING OR USAGE OF TRADE. IN NO EVENT SHALL SMSC BE LIABLE FOR ANY DIRECT, INCIDENTAL, INDIRECT, SPECIAL, PUNITIVE, OR CONSEQUENTIAL DAMAGES; OR FOR LOST DATA, PROFITS, SAVINGS OR REVENUES OF ANY KIND; REGARDLESS OF THE FORM OF ACTION, WHETHER BASED ON CONTRACT; TORT; NEGLIGENCE OF SMSC OR OTHERS; STRICT LIABILITY; BREACH OF WARRANTY; OR OTHERWISE; WHETHER OR NOT ANY REMEDY OF BUYER IS HELD TO HAVE FAILED OF ITS ESSENTIAL PURPOSE, AND WHETHER OR NOT SMSC HAS BEEN ADVISED OF THE POSSIBILITY OF SUCH DAMAGES.

Table of Contents

Chapter 1	Pin Configuration	6
Chapter 2	Block Diagram	8
Chapter 3	Pin Descriptions	9
3.1	PIN Descriptions	9
3.2	Buffer Type Descriptions	16
Chapter 4	Configuration Options	18
4.1	4-Port Hub	18
4.1.1	Hub Configuration Options	18
4.1.2	VBus Detect	18
4.2	36 QFN and 48 QFN Feature Differences	18
4.3	EEPROM Interface	19
4.3.1	Internal Register Set (Common to EEPROM and SMBus)	19
4.3.2	I2C EEPROM	34
4.3.3	In-Circuit EEPROM Programming	34
4.4	SMBus Slave Interface	35
4.4.1	Bus Protocols	35
4.4.2	Invalid Protocol Response Behavior	36
4.4.3	General Call Address Response	36
4.4.4	Slave Device Time-Out	36
4.4.5	Stretching the SCLK Signal	36
4.4.6	SMBus Timing	36
4.4.7	Bus Reset Sequence	37
4.4.8	SMBus Alert Response Address	37
4.5	Default Configuration Option:	37
4.6	Default Strapping Options:	37
4.7	Reset	38
4.7.1	Internal POR Hardware Reset	38
4.7.2	External Hardware RESET_N	38
4.7.3	USB Bus Reset	41
Chapter 5	DC Parameters	43
5.1	Maximum Guaranteed Ratings	43
5.2	Recommended Operating Conditions	43
Chapter 6	AC Specifications	47
6.1	Oscillator/Clock	47
6.1.1	SMBus Interface:	47
6.1.2	I2C EEPROM:	47
6.1.3	USB 2.0	47
Chapter 7	Package Outlines	48

List of Figures

Figure 1.1	USB2514 36-Pin QFN	6
Figure 1.2	USB2514 48-Pin QFN	7
Figure 2.1	USB2514 Block Diagram	8
Figure 4.1	Block Write	35
Figure 4.2	Block Read	36
Figure 4.3	LED Strapping Option	38
Figure 4.4	Reset_N Timing for Default/Strap Option Mode	39
Figure 4.5	Reset_N Timing for EEPROM Mode	40
Figure 4.6	Reset_N Timing for SMBus Mode	41
Figure 6.1	Typical Crystal Circuit	47
Figure 6.2	Formula to find value of C1 and C2	47
Figure 7.1	36-Pin QFN, 6x6mm Body, 0.5mm Pitch	48
Figure 7.2	48-Pin QFN, 7x7mm Body, 0.5mm Pitch	49



Datasheet

List of Tables

Table 3.1	USB2514 Pin Descriptions	9
Table 3.2	SMBus or EEPROM Interface Behavior	15
Table 3.3	USB2514 Power, Ground, No Connect	16
Table 3.4	USB2514 Buffer Type Descriptions	16
Table 4.1	36 QFN and 48 QFN Feature Differences	18
Table 4.2	Internal Default, EEPROM and SMBus Register Memory Map	19
Table 4.3	Port Remap Register for Ports 1 & 2	32
Table 4.4	Port Remap Register for Ports 3 & 4	33
Table 4.5	Reset_N Timing for Default/Strap Option Mode	39
Table 4.6	Reset_N Timing for EEPROM Mode	40
Table 4.7	Reset_N Timing for SMBus Mode	41
Table 5.1	DC Electrical Characteristics	44
Table 5.2	Pin Capacitance	46

Chapter 1 Pin Configuration

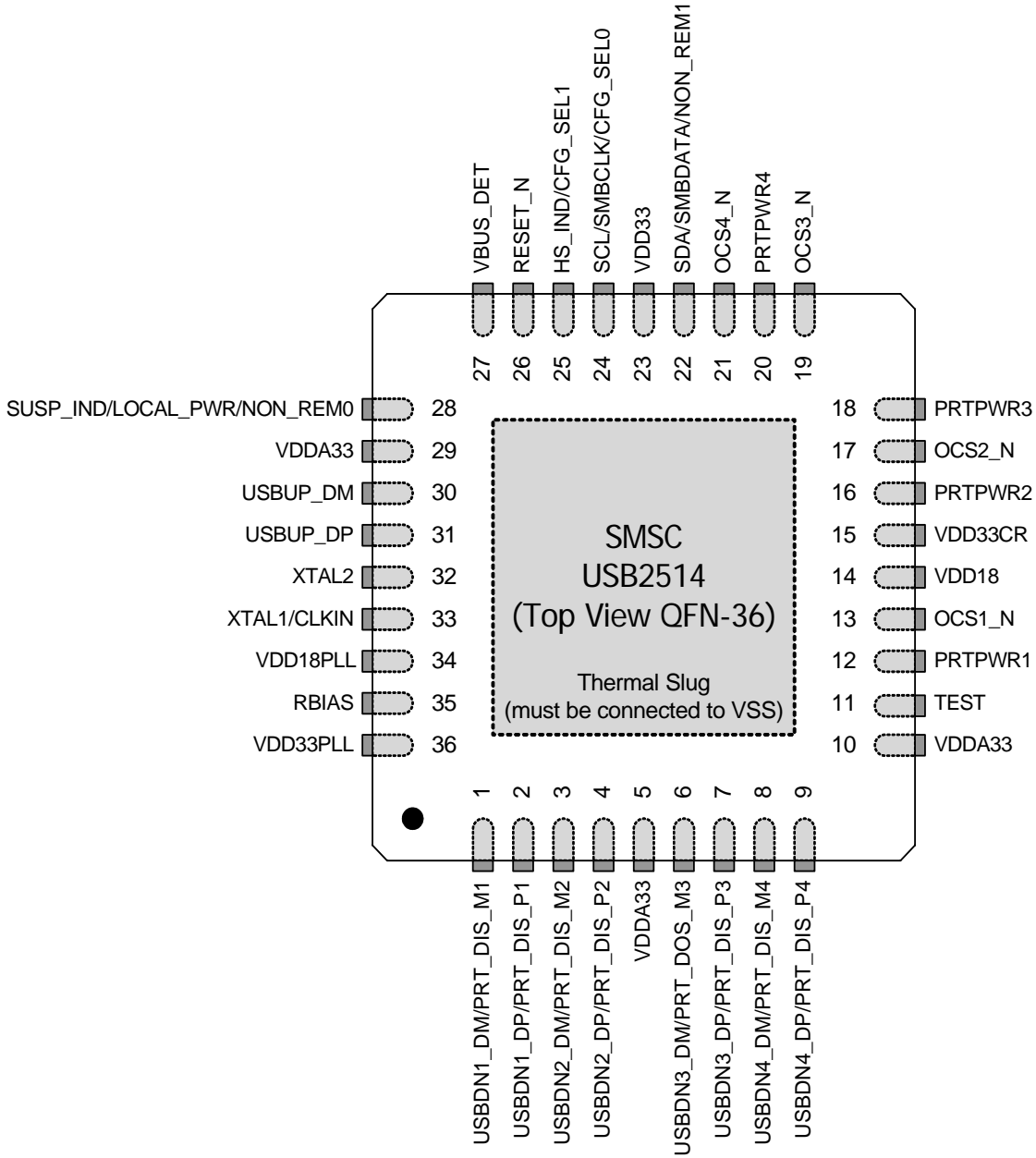

 Indicates pins on the bottom of the device.

Figure 1.1 USB2514 36-Pin QFN



 Indicates pins on the bottom of the device.

Figure 1.2 USB2514 48-Pin QFN

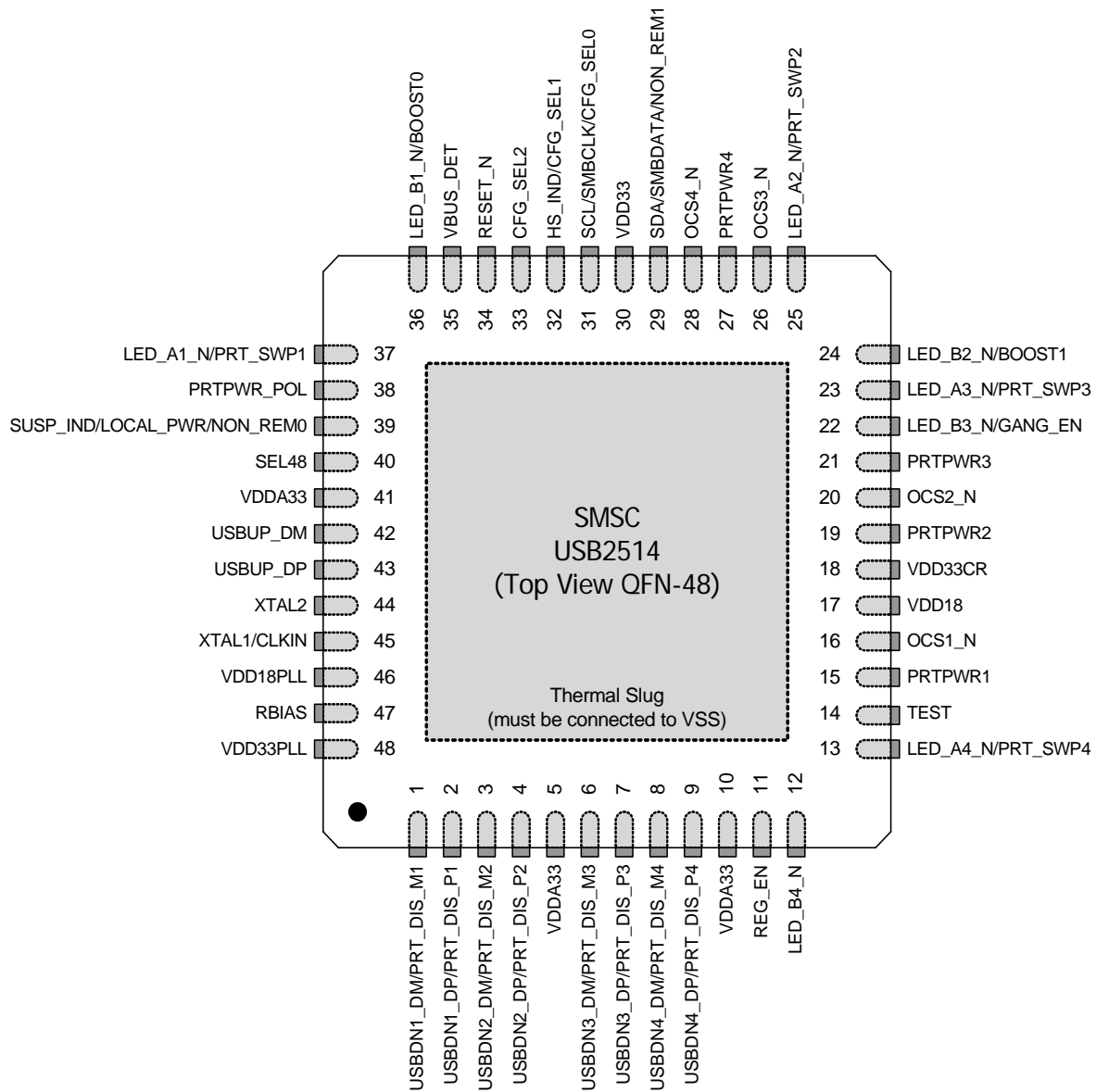
Chapter 2 Block Diagram

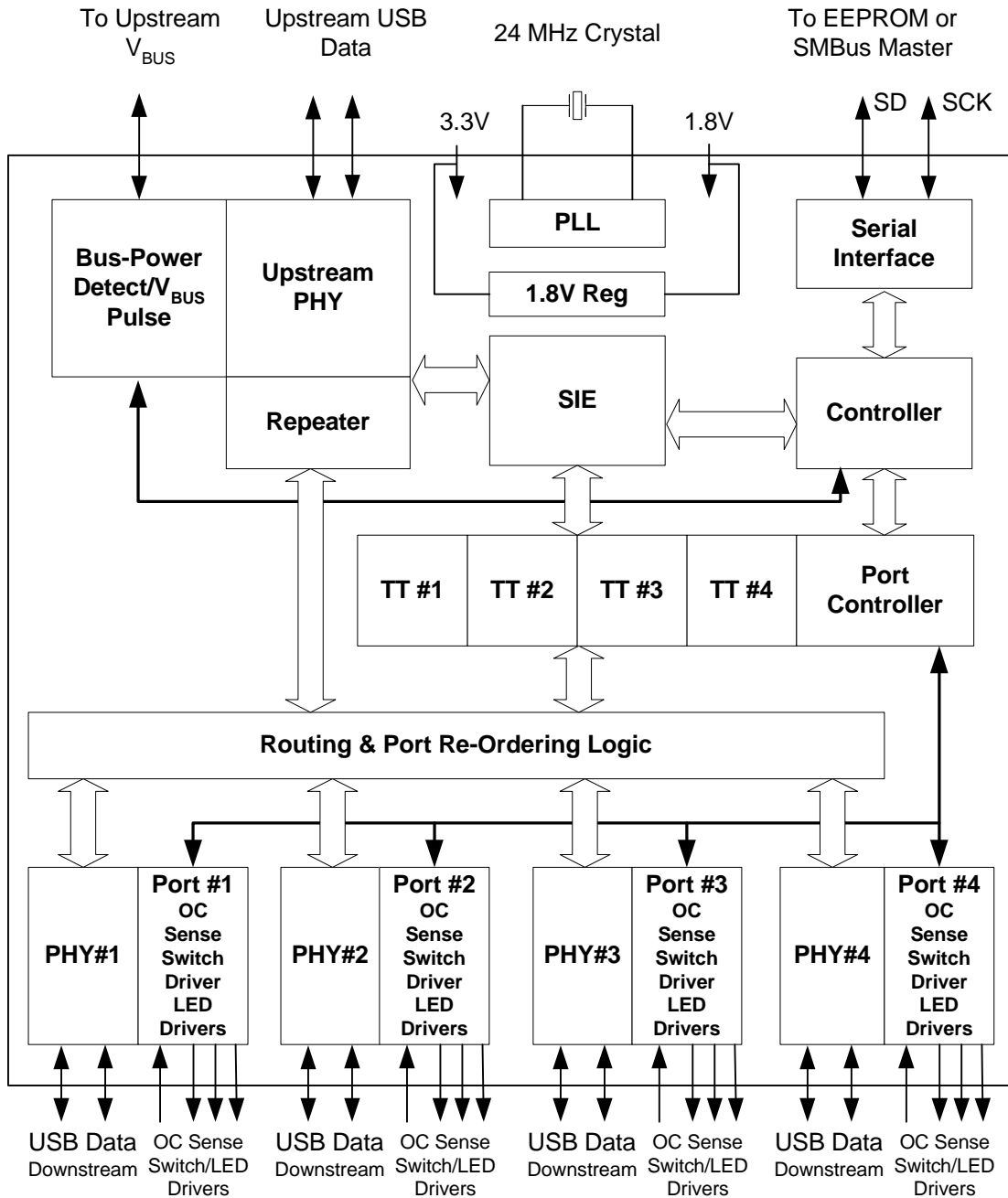

Figure 2.1 USB2514 Block Diagram

Chapter 3 Pin Descriptions

3.1 PIN Descriptions

This section provides a detailed description of each signal. The signals are arranged in functional groups according to their associated interface.

The “N” symbol in the signal name indicates that the active, or asserted, state occurs when the signal is at a low voltage level. When “N” is not present before the signal name, the signal is asserted when at the high voltage level.

The terms assertion and negation are used exclusively. This is done to avoid confusion when working with a mixture of “active low” and “active high” signals. The term assert, or assertion, indicates that a signal is active, independent of whether that level is represented by a high or low voltage. The term negate, or negation, indicates that a signal is inactive.

Table 3.1 USB2514 Pin Descriptions

SYMBOL	36 QFN	48 QFN	BUFFER TYPE	DESCRIPTION
UPSTREAM USB INTERFACES				
USBUP_DP USBUP_DM	31 30	43 42	IO-U	USB Bus Data These pins connect to the upstream USB bus data signals (Host port, or upstream hub).
VBUS_DET	27	35	I/O12	Detect Upstream VBUS Power Detects state of Upstream VBUS power. The SMSC Hub monitors VBUS_DET to determine when to assert the internal D+ pull-up resistor (signaling a connect event). When designing a detachable hub, this pin must be connected to the VBUS power pin of the USB port that is upstream of the hub. For self-powered applications with a permanently attached host, this pin must be connected to 3.3V (typically VDD33).
DOWNSTREAM 4-PORT USB 2.0 INTERFACE				
USBDN_DP[4:1]/ PRT_DIS_P[4:1] &	9 7 4 2	9 7 4 2	IO-U	High-Speed USB Data & Port Disable Strap Option These pins connect to the downstream USB peripheral devices attached to the hub's port.
USBDN_DM[4:1]/ PRT_DIS_M[4:1]	8 6 3 1	8 6 3 1		Downstream Port Disable Strap option: If this strap is enabled by package and configuration settings (see Table 3.2), this pin will be sampled at RESET_N negation to determine if the port is disabled. Both USB data pins for the corresponding port must be tied to the VDDA33 to disable the associated downstream port.
P RTPWR[4:1]	20 18 16 12	27 21 19 15	O12	USB Power Enable Enables power to USB peripheral devices downstream. The active signal level of the P RTPWR[4:1] pins is determined by the Power Polarity Strapping function of the P RTPWR_POL pin.

Table 3.1 USB2514 Pin Descriptions (continued)

SYMBOL	36 QFN	48 QFN	BUFFER TYPE	DESCRIPTION
LED_A[4:1]_N/ PRT_SWP[4:1]	n/a	13 23 25 37	I/O12	<p>Port LED Indicators & Port Swap strapping option</p> <p>Indicator LED for ports 1-4. Will be active low when LED support is enabled via EEPROM or SMBus.</p> <p>If this strap is enabled by package and configuration settings (see Table 3.2), this pin will be sampled at RESET_N negation to determine the electrical connection polarity of the downstream USB Port pins (USB_DP and USB_DM).</p> <p>Also, the active state of the LED will be determined as follows:</p> <p>'0' = Port Polarity is normal, and the LED is active high.</p> <p>'1' = Port Polarity (for USB_DP and USB_DM) is swapped, and the LED is active low.</p>
LED_B4_N	n/a	12	I/O12	<p>Enhanced Port 4 LED</p> <p>Enhanced Indicator LED for port 4. Will be active low when LED support is enabled via EEPROM or SMBus.</p>
LED_B3_N/ GANG_EN	n/a	22	I/O12	<p>Enhanced Port 3 LED & Gang Power and Overcurrent Strap Option</p> <p>Enhanced Indicator LED for port 3. Will be active low when LED support is enabled via EEPROM or SMBus.</p> <p>GANG_EN: Selects between Gang or Individual Port power and Over Current sensing.</p> <p>If this strap is enabled by package and configuration settings (see Table 3.2), this pin will be sampled at RESET_N negation to determine the mode as follows:</p> <p>'0' = Individual sensing & switching, and LED_B3_N is active high.</p> <p>'1' = Ganged sensing & switching, and LED_B3_N is active low.</p>
LED_B[2:1]_N/ BOOST[1:0]	n/a	24 36	I/O12	<p>Enhanced Port [2:1] LED & Phy Boost strapping option</p> <p>Enhanced Indicator LED for ports 1 & 2. Will be active low when LED support is enabled via EEPROM or SMBus.</p>

Table 3.1 USB2514 Pin Descriptions (continued)

SYMBOL	36 QFN	48 QFN	BUFFER TYPE	DESCRIPTION
				<p>BOOST[1:0], If this strap is enabled by package and configuration settings (see Table 3.2), this pin will be sampled at RESET_N negation to determine if all PHY ports (upstream and downstream) operate at a normal or boosted electrical level. Also, the active state of the LEDs will be determined as follows:</p> <p>See for BOOST values: Section 4.3.1.26, "Register F6h: Boost_Up" and Section 4.3.1.27, "Register F8h: Boost_4:0".</p> <p>BOOST[1:0] = BOOST_IOUT[1:0]</p> <p>BOOST[1:0] = '00', LED_B2_N is active high, LED_B1_N is active high.</p> <p>BOOST[1:0] = '01', LED_B2_N is active high, LED_B1_N is active low.</p> <p>BOOST[1:0] = '10', LED_B2_N is active low, LED_B1_N is active high.</p> <p>BOOST[1:0] = '11', LED_B2_N is active low, LED_B1_N is active low.</p>
P RTPWR_POL	n/a	38	IPU	<p>Port Power Polarity strapping</p> <p>Port Power Polarity strapping determination for the active signal polarity of the [4:1]P RTPWR pins.</p> <p>While RESET_N is asserted, the logic state of this pin will (through the use of internal combinatorial logic) determine the active state of the [4:1]P RTPWR pins in order to ensure that downstream port power is not inadvertently enabled to inactive ports during a hardware reset.</p> <p>When RESET_N is negated, the logic value will be latched internally, and will retain the active signal polarity for the P RTPWR[4:1] pins.</p> <p>'1' = P RTPWR[4:1]_P/N pins have an active 'high' polarity '0' = P RTPWR[4:1]_P/N pins have an active 'low' polarity</p> <p>Warning: Active Low port power controllers may glitch the downstream port power when system power is first applied. Care should be taken when designing with active low components!</p> <p>Note: If P RTPWR_POL is not an available pin on the package, the hub will support active high power controllers only!</p>
OCS[4:1]_N	21 19 17 13	28 26 20 16	IPU	<p>Over Current Sense</p> <p>Input from external current monitor indicating an over-current condition. {Note: Contains internal pull-up to 3.3V supply}</p>

Table 3.1 USB2514 Pin Descriptions (continued)

SYMBOL	36 QFN	48 QFN	BUFFER TYPE	DESCRIPTION
RBIAS	35	47	I-R	USB Transceiver Bias A 12.0kΩ (+/- 1%) resistor is attached from ground to this pin to set the transceiver's internal bias settings.
SERIAL PORT INTERFACE				
SDA/ SMBDATA/ NON_REM1	22	29	I/OSD12	Serial Data / SMB Data & Port Non Removable Strap Option NON_REM1: Non removable port strap option. If this strap is enabled by package and configuration settings (see Table 3.2), this pin will be sampled (in conjunction with LOCAL_PWR/SUSP_IND/NON_REM0) at RESET_N negation to determine if imports [4:1] contain permanently attached (non-removable) devices: NON_REM[1:0] = '00', All ports are removable, NON_REM[1:0] = '01', Port 1 is nonremovable, NON_REM[1:0] = '10', Ports 1 & 2 are non-removable, NON_REM[1:0] = '11', Ports 1, 2 & 3 are non-removable
SCL/ SMBCLK/ CFG_SEL0	24	31	I/OSD12	Serial Clock (SCL) SMBus Clock (SMBCLK) Configuration Select_SEL0: The logic state of this multifunction pin is internally latched on the rising edge of RESET_N (RESET_N negation), and will determine the hub configuration method as described in Table 3.2 , " SMBus or EEPROM Interface Behavior ".
HS_IND/ CFG_SEL1	25	32	I/O12	High-Speed Upstream port indicator & Configuration Programming Select HS_IND: High Speed Indicator for upstream port connection speed. The active state of the LED will be determined as follows: CFG_SEL1 = '0', HS_IND is active high, CFG_SEL1 = '1', HS_IND is active low, 'Asserted' = Hub is connected at HS 'Negated' = Hub is connected at FS CFG_SEL1: The logic state of this pin is internally latched on the rising edge of RESET_N (RESET_N negation), and will determine the hub configuration method as described in Table 3.2 , " SMBus or EEPROM Interface Behavior ".

Table 3.1 USB2514 Pin Descriptions (continued)

SYMBOL	36 QFN	48 QFN	BUFFER TYPE	DESCRIPTION
CFG_SEL2	n/a	33	I	<p>Configuration Programming Select</p> <p>Note: This pin is not available in all packages; it is held to a logic '0' when not available</p> <p>The logic state of this pin is internally latched on the rising edge of RESET_N (RESET_N negation), and will determine the hub configuration method as described in Table 3.2, "SMBus or EEPROM Interface Behavior"</p>
MISC				
XTAL1/ CLKIN	33	45	ICLKx	<p>Crystal Input/External Clock Input</p> <p>24MHz crystal or external clock input. This pin connects to either one terminal of the crystal or to an external 24/48MHz clock when a crystal is not used.</p> <p>Note: 48MHz only available in 48 QFN.</p>
XTAL2	32	44	OCLKx	<p>Crystal Output</p> <p>24MHz Crystal This is the other terminal of the crystal, or pulled high when an external clock source is used to drive XTAL1/CLKIN. This output must not be used to drive any external circuitry other than the crystal circuit.</p>
RESET_N	26	34	IS	<p>RESET Input</p> <p>The system can reset the chip by driving this input low. The minimum active low pulse is 1 us.</p> <p>When the RESET_N pin is pulled to VDD33, the internal POR (Power on Reset) is enabled and no external reset circuitry is required. The internal POR holds the internal logic in reset until the power supplies are stable.</p>

Table 3.1 USB2514 Pin Descriptions (continued)

SYMBOL	36 QFN	48 QFN	BUFFER TYPE	DESCRIPTION
SUSP_IND/ LOCAL_PWR/ NON_REM0	28	39	I/O	<p>Active/Suspend status LED or Local-Power & Non Removable Strap Option</p> <p>Suspend Indicator: Indicates USB state of the hub. 'negated' = Unconfigured, or configured and in USB Suspend 'asserted' = Hub is configured, and is active (i.e., not in suspend)</p> <p>Local Power: Detects availability of local self-power source. Low = Self/local power source is NOT available (i.e., Hub gets all power from Upstream USB VBus). High = Self/local power source is available.</p> <p>NON_REM0 Strap Option: If this strap is enabled by package and configuration settings (see Table 3.2), this pin will be sampled (in conjunction with NON_REM1) at RESET_N negation to determine if ports [4:1] contain permanently attached (non-removable) devices. Also, the active state of the LED will be determined as follows:</p> <p>NON_REM[1:0] = '00', All ports are removable, and the LED is active high</p> <p>NON_REM[1:0] = '01', Port 1 is nonremovable, and the LED is active low</p> <p>NON_REM[1:0] = '10', Ports 1 & 2 are non-removable, and the LED is active high</p> <p>NON_REM[1:0] = '11', Ports 1, 2 & 3 are non-removable, and the LED is active low</p>
TEST	11	14	IPD	<p>TEST pin</p> <p>XNOR continuity tests all signal pins on the hub, please contact your SMSC representative for a detailed description of how this test mode is enabled and utilized.</p>
SEL48	n/a	40	I	<p>Select 48 MHz clock input</p> <p>48MHz external clock input select. When the hub is clocked from an external clock source, this pin selects either 24MHz or 48MHz mode.</p> <p>'0' = 24MHz '1' = 48MHz</p>
REG_EN	n/a	11	IPU	<p>Regulator Enable</p> <p>REG_EN: This pin is internally pulled up to enable the internal 1.8V regulators, and this pin should be treated as a no-connect. In order to disable the regulators, this pin will need to be externally connected to ground. When the internal regulator is enabled, the 1.8V power pins must be left unconnected, except for the required bypass capacitors.</p>

Table 3.2 SMBus or EEPROM Interface Behavior

	CFG_SEL2	CFG_SEL1	CFG_SEL0	SMBUS OR EEPROM INTERFACE BEHAVIOR
36-Pin QFN	N/A	0	0	Internal Default Configuration <ul style="list-style-type: none"> ■ Strap Options Enabled ■ Port Indicators Not Supported
48-Pin QFN	0	0	0	
36-Pin QFN	N/A	0	1	Configured as an SMBus slave for external download of user-defined descriptors. <ul style="list-style-type: none"> ■ SMBus slave address 58 (0101100x) ■ Strap Options Disabled ■ All Settings Controlled by Registers
48-Pin QFN	0	0	1	
36-Pin QFN	N/A	1	0	Internal Default Configuration <ul style="list-style-type: none"> ■ Strap Options Enabled ■ Bus Power Operation ■ LED Mode = USB
48-Pin QFN	0	1	0	
36-Pin QFN	N/A	1	1	2-Wire I2C EEPROMS are supported. <ul style="list-style-type: none"> ■ Strap Options Disabled ■ All Settings Controlled by Registers
48-Pin QFN	0	1	1	
48-Pin QFN	1	0	0	Internal Default Configuration <ul style="list-style-type: none"> ■ Strap Options Disabled ■ Dynamic Power Switching Enabled
48-Pin QFN	1	0	1	Internal Default Configuration <ul style="list-style-type: none"> ■ Strap Options Disabled ■ Dynamic Power Switching Enabled ■ LED Mode = USB
48-Pin QFN	1	1	0	Internal Default Configuration <ul style="list-style-type: none"> ■ Strap Options Disabled
48-Pin QFN	1	1	1	Internal Default Configuration <ul style="list-style-type: none"> ■ Strap Options Disabled ■ LED Mode = USB ■ Ganged Power Switching ■ Ganged Over-Current Sensing

Notes:
 Denotes 48-Pin QFN

 Denotes 36-Pin QFN

Table 3.3 USB2514 Power, Ground, No Connect

PACKAGE SYMBOL	36 QFN	48 QFN	FUNCTION
VDD18	14	17	VDD Core +1.8V core power. If the internal regulator is enabled, then this pin must have a 1.0 μ F (or greater) \pm 20% (ESR <0.1 Ω) capacitor to VSS.
VDD33PLL	36	48	VDD 3.3 PLL Regulator Reference +3.3V power supply for the PLL. If the internal PLL 1.8V regulator is enabled, then this pin acts as the regulator input.
VDDPLL18	34	46	VDD PLL +1.8V Filtered analog power for internal PLL. If the internal regulator is enabled, then this pin must have a 1.0 μ F (or greater) \pm 20% (ESR <0.1 Ω) capacitor to VSS.
VDDA33	5 10 29	5 10 41	VDD Analog I/O +3.3V Filtered analog PHY power, shared between adjacent ports.
VDD33/VDD33CR	23 15	30 18	VDDIO/VDD 3.3 Core Regulator Reference +3.3V power supply for the Digital I/O If the internal core regulator is enabled, then VDD33CR acts as the regulator input.
VSS	n/a	n/a	VSS Ground

3.2 Buffer Type Descriptions

Table 3.4 USB2514 Buffer Type Descriptions

BUFFER	DESCRIPTION
I	Input.
IPD	Input with internal weak pull-down resistor.
IPU	Input with internal weak pull-up resistor.
IS	Input with Schmitt trigger.
O12	Output 12mA.
OD12	Open drain... 12mA sink.
I/O12	Input/Output buffer with 12mA sink and 12mA source.

Table 3.4 USB2514 Buffer Type Descriptions (continued)

BUFFER	DESCRIPTION
I/OSD12	Open drain...12mA sink with Schmitt trigger, and must meet I2C-Bus Specification Version 2.1 requirements.
ICLKx	XTAL clock input.
OCLKx	XTAL clock output.
I-R	RBIAS.
I/O-U	Analog Input/Output Defined in USB specification.
AIO	Analog Input/Output.

Chapter 4 Configuration Options

4.1 4-Port Hub

SMSC's USB 2.0 4-Port Hub is fully specification compliant to the Universal Serial Bus Specification Revision 2.0 April 27, 2000 (12/7/2000 and 5/28/2002 Errata). Please reference Chapter 10 (Hub Specification) for general details regarding Hub operation and functionality.

For performance reasons, the 4-Port Hub provides 1 Transaction Translator (TT) per port (defined as Multi-TT configuration), divided into 4 non-periodic buffers per TT.

4.1.1 Hub Configuration Options

The SMSC Hub supports a large number of features (some are mutually exclusive), and must be configured in order to correctly function when attached to a USB host controller. There are three principal ways to configure the hub: SMBus, EEPROM, or by internal default settings (with or without pin strapping option over-rides). In all cases, the configuration method will be determined by the CFG_SEL2, CFG_SEL1 and CFG_SEL0 pins immediately after RESET_N negation.

4.1.1.1 Power Switching Polarity

The selection of active state "polarity" for the PRTPWR pins is made by a strapping option only (the PRTPWR_POL pin).

Note: If PRTPWR_POL is not an available pin on the package, the hub will support active high power controllers only!

4.1.2 VBus Detect

According to Section 7.2.1 of the USB 2.0 Specification, a downstream port can never provide power to its D+ or D- pull-up resistors unless the upstream port's VBUS is in the asserted (powered) state. The VBUS_DET pin on the Hub monitors the state of the upstream VBUS signal and will not pull-up the D+ resistor if VBUS is not active. If VBUS goes from an active to an inactive state (Not Powered), Hub will remove power from the D+ pull-up resistor within 10 seconds.

4.2 36 QFN and 48 QFN Feature Differences

Table 4.1 36 QFN and 48 QFN Feature Differences

36 QFN	48 QFN	FEATURE
N/A	Available	48MHz clock input mode
N/A	Available	External 1.8V regulators
N/A	Available	Port LED Indicators
N/A	Available	Port Swap Strapping Options
Available	N/A	Only Active High Port Power Control is supported in 36 QFN package
Available	N/A	Boost Default Level is used; see Table 4.2, "Internal Default, EEPROM and SMBus Register Memory Map"

Datasheet

4.3 EEPROM Interface

The SMSC Hub can be configured via a 2-wire (I2C) EEPROM (256x8). (Please see [Table 3.1](#) for specific details on how to enable configuration via an I2C EEPROM).

The Internal state-machine will (when configured for EEPROM support) read the external EEPROM for configuration data. The hub will then “attach” to the upstream USB host.

Note: The Hub does not have the capacity to write, or “Program,” an external EEPROM. The Hub only has the capability to read external EEPROMs. The external eeprom will be read (even if it is blank or non-populated), and the hub will be “configured” with the values that are read.

Please see Internal Register Set (Common to EEPROM and SMBus) for a list of data fields available.

4.3.1 Internal Register Set (Common to EEPROM and SMBus)

Table 4.2 Internal Default, EEPROM and SMBus Register Memory Map

REG ADDR	R/W	REGISTER NAME	ABBR	INTERNAL DEFAULT ROM	SMBUS AND EEPROM POR VALUES
00h	R/W	VID LSB	VIDL	24h	0x00
01h	R/W	VID MSB	VIDM	04h	0x00
02h	R/W	PID LSB	PIDL	14h	0x00
03h	R/W	PID MSB	PIDM	25h	0x00
04h	R/W	DID LSB	DIDL	00h	0x00
05h	R/W	DID MSB	DIDM	00h	0x00
06h	R/W	Config Data Byte 1	CFG1	9Bh	0x00
07h	R/W	Config Data Byte 2	CFG2	10h	0x00
08h	R/W	Config Data Byte 3	CFG3	00h	0x00
09h	R/W	Non-Removable Devices	NRD	00h	0x00
0Ah	R/W	Port Disable (Self)	PDS	00h	0x00
0Bh	R/W	Port Disable (Bus)	PDB	00h	0x00
0Ch	R/W	Max Power (Self)	MAXPS	01h	0x00
0Dh	R/W	Max Power (Bus)	MAXPB	64h	0x00
0Eh	R/W	Hub Controller Max Current (Self)	HCMCS	01h	0x00
0Fh	R/W	Hub Controller Max Current (Bus)	HCMCB	64h	0x00
10h	R/W	Power-on Time	PWRT	32h	0x00
11h	R/W	LANG_ID_H	LANGIDH	00h	0x00
12h	R/W	LANG_ID_L	LANGIDL	00h	0x00
13h	R/W	MFR_STR_LEN	MFRSL	00h	0x00
14h	R/W	PRD_STR_LEN	PRDSL	00h	0x00

Table 4.2 Internal Default, EEPROM and SMBus Register Memory Map (continued)

REG ADDR	R/W	REGISTER NAME	ABBR	INTERNAL DEFAULT ROM	SMBUS AND EEPROM POR VALUES
15h	R/W	SER_STR_LEN	SERSL	00h	0x00
16h-53h	R/W	MFR_STR	MANSTR	00h	0x00
54h-91h	R/W	PROD_STR	PRDSTR	00h	0x00
92h-Cfh	R/W	SER_STR	SERSTR	00h	0x00
D0h-F5h	R/W	Reserved	N/A	01h	0x00
F6h	R/W	Boost_Up	BOOSTUP	00h	0x00
F7h	R/W	Reserved	N/A	00h	0x00
F8h	R/W	Boost_4:0	BOOST40	00h	0x00
F9h	R/W	Reserved	N/A	00h	0x00
FAh	R/W	Port Swap	PRTSP	00h	0x00
FBh	R/W	Port Remap 12	PRTR12	00h	0x00
FCh	R/W	Port Remap 34	PRTR34	00h	0x00
FDh-FEh	R/W	Reserved	N/A	00h	0x00
FFh	R/W	Status/Command Note: SMBus register only	STCD	00h	0x00

4.3.1.1 Register 00h: Vendor ID (LSB)

BIT NUMBER	BIT NAME	DESCRIPTION
7:0	VID_LSB	Least Significant Byte of the Vendor ID. This is a 16-bit value that uniquely identifies the Vendor of the user device (assigned by USB-Interface Forum). This field is set by the OEM using either the SMBus or EEPROM interface options.

4.3.1.2 Register 01h: Vendor ID (MSB)

BIT NUMBER	BIT NAME	DESCRIPTION
7:0	VID_MSB	Most Significant Byte of the Vendor ID. This is a 16-bit value that uniquely identifies the Vendor of the user device (assigned by USB-Interface Forum). This field is set by the OEM using either the SMBus or EEPROM interface options.

Datasheet

4.3.1.3 Register 02h: Product ID (LSB)

BIT NUMBER	BIT NAME	DESCRIPTION
7:0	PID_LSB	Least Significant Byte of the Product ID. This is a 16-bit value that the Vendor can assign that uniquely identifies this particular product (assigned by OEM). This field is set by the OEM using either the SMBus or EEPROM interface options.

4.3.1.4 Register 03h: Product ID (MSB)

BIT NUMBER	BIT NAME	DESCRIPTION
7:0	PID_MSB	Most Significant Byte of the Product ID. This is a 16-bit value that the Vendor can assign that uniquely identifies this particular product (assigned by OEM). This field is set by the OEM using either the SMBus or EEPROM interface options.

4.3.1.5 Register 04h: Device ID (LSB)

BIT NUMBER	BIT NAME	DESCRIPTION
7:0	DID_LSB	Least Significant Byte of the Device ID. This is a 16-bit device release number in BCD format (assigned by OEM). This field is set by the OEM using either the SMBus or EEPROM interface options.

4.3.1.6 Register 05h: Device ID (MSB)

BIT NUMBER	BIT NAME	DESCRIPTION
7:0	DID_MSB	Most Significant Byte of the Device ID. This is a 16-bit device release number in BCD format (assigned by OEM). This field is set by the OEM using either the SMBus or EEPROM interface options.

4.3.1.7 Register 06h: CONFIG_BYTE_1

BIT NUMBER	BIT NAME	DESCRIPTION
7	SELF_BUS_PWR	<p>Self or Bus Power: Selects between Self- and Bus-Powered operation.</p> <p>The Hub is either Self-Powered (draws less than 2mA of upstream bus power) or Bus-Powered (limited to a 100mA maximum of upstream power prior to being configured by the host controller). When configured as a Bus-Powered device, the SMSC Hub consumes less than 100mA of current prior to being configured. After configuration, the Bus-Powered SMSC Hub (along with all associated hub circuitry, any embedded devices if part of a compound device, and 100mA per externally available downstream port) must consume no more than 500mA of upstream VBUS current. The current consumption is system dependent, and the OEM must ensure that the USB 2.0 specifications are not violated. When configured as a Self-Powered device, <1mA of upstream VBUS current is consumed and all ports are available, with each port being capable of sourcing 500mA of current. This field is set by the OEM using either the SMBus or EEPROM interface options. Please see the description under Dynamic Power for the self/bus power functionality when dynamic power switching is enabled.</p> <p>0 = Bus-Powered operation 1 = Self-Powered operation</p> <p>Note: If Dynamic Power Switching is enabled, this bit is ignored and the LOCAL_PWR pin is used to determine if the hub is operating from self or bus power.</p>
6	Reserved	Reserved
5	HS_DISABLE	<p>High Speed Disable: Disables the capability to attach as either a High/Full-speed device, and forces attachment as Full-speed only (i.e. no High-Speed support).</p> <p>0 = High-/Full-Speed 1 = Full-Speed-Only (High-Speed disabled!)</p>
4	MTT_ENABLE	<p>Multi-TT enable: Enables one transaction translator per port operation.</p> <p>Selects between a mode where only one transaction translator is available for all ports (Single-TT), or each port gets a dedicated transaction translator (Multi-TT) {Note: The host may force Single-TT mode only}.</p> <p>0 = single TT for all ports 1 = one TT per port (multiple TT's supported)</p>
3	EOP_DISABLE	<p>EOP Disable: Disables EOP generation of EOF1 when in Full-Speed mode. During FS operation only, this permits the Hub to send EOP if no downstream traffic is detected at EOF1. See Section 11.3.1 of the USB 2.0 Specification for additional details. Note: generation of an EOP at the EOF1 point may prevent a Host controller (operating in FS mode) from placing the USB bus in suspend.</p> <p>0 = EOP generation is normal 1 = EOP generation is disabled</p>
2:1	CURRENT_SNS	<p>Over Current Sense: Selects current sensing on a port-by-port basis, all ports ganged, or none (only for bus-powered hubs). The ability to support current sensing on a port or ganged basis is hardware implementation dependent.</p> <p>00 = Ganged sensing (all ports together) 01 = Individual port-by-port 1x = Over current sensing not supported (must only be used with Bus-Powered configurations!)</p>

Datasheet

BIT NUMBER	BIT NAME	DESCRIPTION
0	PORT_PWR	<p>Port Power Switching: Enables power switching on all ports simultaneously (ganged), or port power is individually switched on and off on a port- by-port basis (individual). The ability to support power enabling on a port or ganged basis is hardware implementation dependent.</p> <p>0 = Ganged switching (all ports together) 1 = Individual port-by-port switching</p>

4.3.1.8 Register 07h: Configuration Data Byte 2

BIT NUMBER	BIT NAME	DESCRIPTION
7	DYNAMIC	<p>Dynamic Power Enable: Controls the ability of the Hub to automatically change from Self-Powered operation to Bus-Powered operation if the local power source is removed or is unavailable (and from Bus-Powered to Self-Powered if the local power source is restored). {Note: If the local power source is available, the Hub will always switch to Self-Powered operation.}</p> <p>When Dynamic Power switching is enabled, the Hub detects the availability of a local power source by monitoring the external LOCAL_PWR pin. If the Hub detects a change in power source availability, the Hub immediately disconnects and removes power from all downstream devices and disconnects the upstream port. The Hub will then re-attach to the upstream port as either a Bus-Powered Hub (if local-power is unavailable) or a Self-Powered Hub (if local power is available).</p> <p>0 = No Dynamic auto-switching 1 = Dynamic Auto-switching capable</p>
6	Reserved	Reserved
5:4	OC_TIMER	<p>OverCurrent Timer: Over Current Timer delay.</p> <p>00 = 0.1ms 01 = 4ms 10 = 8ms 11 = 16ms</p>
3	COMPOUND	<p>Compound Device: Allows the OEM to indicate that the Hub is part of a compound (see the USB Specification for definition) device. The applicable port(s) must also be defined as having a "Non-Removable Device".</p> <p>Note: When configured via strapping options, declaring a port as non-removable automatically causes the hub controller to report that it is part of a compound device.</p> <p>0 = No 1 = Yes, Hub is part of a compound device</p>
2:0	Reserved	Reserved

4.3.1.9 Register 08h: Configuration Data Byte 3

BIT NUMBER	BIT NAME	DESCRIPTION
7:4	Reserved	Reserved
3	PRTMAP_EN	<p>Port Re-mapping enable: Selects the method used by the hub to assign port numbers and disable ports.</p> <p>'0' = Standard Mode '1' = Port Re-map mode</p>
2:1	LED_MODE	<p>LED Mode Selection: The LED_A[4:1]_N and LED_B[4:1]_N pins support several different modes of operation.</p> <p>'00' = USB Mode '01' = Speed Indication Mode '10' = Same as '00', USB Mode '11' = Same as '00', USB Mode</p> <p>Warning: Do not enable an LED mode that requires LED pins that are not available in the specific package being used in the implementation!</p> <p>Note: The Hub will only report that it supports LED's to the host when USB mode is selected. All other modes will be reported as No LED Support.</p>
0	STRING_EN	<p>Enables String Descriptor Support</p> <p>'0' = String Support Disabled '1' = String Support Enabled</p>

4.3.1.10 Register 09h: Non-Removable Device

BIT NUMBER	BIT NAME	DESCRIPTION
7:0	NR_DEVICE	<p>Non-Removable Device: Indicates which port(s) include non-removable devices. '0' = port is removable, '1' = port is non-removable.</p> <p>Informs the Host if one of the active ports has a permanent device that is undetachable from the Hub. (Note: The device must provide its own descriptor data.)</p> <p>When using the internal default option, the NON_REM[1:0] pins will designate the appropriate ports as being non-removable.</p> <p>Bit 7= Reserved Bit 6= Reserved Bit 5= Reserved Bit 4= 1; Port 4 non-removable Bit 3= 1; Port 3 non-removable Bit 2= 1; Port 2 non-removable Bit 1= 1; Port 1 non-removable Bit 0 is Reserved, always = '0'</p>

Datasheet

4.3.1.11 Register 0Ah: Port Disable For Self Powered Operation

BIT NUMBER	BIT NAME	DESCRIPTION
7:0	PORT_DIS_SP	<p>Port Disable Self-Powered: Disables 1 or more contiguous ports. '0' = port is available, '1' = port is disabled.</p> <p>During Self-Powered operation when remapping mode is disabled (PRTMAP_EN=0'), this selects the ports which will be permanently disabled, and are not available to be enabled or enumerated by a Host Controller. The ports can be disabled in any order, the internal logic will automatically report the correct number of enabled ports to the USB Host, and will reorder the active ports in order to ensure proper function.</p> <p>Bit 7= Reserved Bit 6= Reserved Bit 5= Reserved Bit 4= 1; Port 4 is disabled Bit 3= 1; Port 3 is disabled Bit 2= 1; Port 2 is disabled Bit 1= 1; Port 1 is disabled Bit 0 is Reserved, always = '0'</p>

4.3.1.12 Register 0Bh: Port Disable For Bus Powered Operation

BIT NUMBER	BIT NAME	DESCRIPTION
7:0	PORT_DIS_BP	<p>Port Disable Bus-Powered: Disables 1 or more contiguous ports. '0' = port is available, '1' = port is disabled.</p> <p>During Self-Powered operation when remapping mode is disabled (PRTMAP_EN=0'), this selects the ports which will be permanently disabled, and are not available to be enabled or enumerated by a Host Controller. The ports can be disabled in any order, the internal logic will automatically report the correct number of enabled ports to the USB Host, and will reorder the active ports in order to ensure proper function.</p> <p>When using the internal default option, the PRT_DIS[1:0] pins will disable the appropriate ports.</p> <p>Bit 7= Reserved Bit 6= Reserved Bit 5= Reserved Bit 4= 1; Port 4 is disabled Bit 3= 1; Port 3 is disabled Bit 2= 1; Port 2 is disabled Bit 1= 1; Port 1 is disabled Bit 0 is Reserved, always = '0'</p>

4.3.1.13 Register 0Ch: Max Power For Self Powered Operation

BIT NUMBER	BIT NAME	DESCRIPTION
7:0	MAX_PWR_SP	<p>Max Power Self_Powered: Value in 2mA increments that the Hub consumes from an upstream port (VBUS) when operating as a self-powered hub. This value includes the hub silicon along with the combined power consumption (from VBUS) of all associated circuitry on the board. This value also includes the power consumption of a permanently attached peripheral if the hub is configured as a compound device, and the embedded peripheral reports 0mA in its descriptors.</p> <p>Note: The USB 2.0 Specification does not permit this value to exceed 100mA</p>

4.3.1.14 Register 0Dh: Max Power For Bus Powered Operation

BIT NUMBER	BIT NAME	DESCRIPTION
7:0	MAX_PWR_BP	<p>Max Power Bus_Powered: Value in 2mA increments that the Hub consumes from an upstream port (VBUS) when operating as a bus-powered hub. This value includes the hub silicon along with the combined power consumption (from VBUS) of all associated circuitry on the board. This value also includes the power consumption of a permanently attached peripheral if the hub is configured as a compound device, and the embedded peripheral reports 0mA in its descriptors.</p>

4.3.1.15 Register 0Eh: Hub Controller Max Current For Self Powered Operation

BIT NUMBER	BIT NAME	DESCRIPTION
7:0	HC_MAX_C_SP	<p>Hub Controller Max Current Self-Powered: Value in 2mA increments that the Hub consumes from an upstream port (VBUS) when operating as a self-powered hub. This value includes the hub silicon along with the combined power consumption (from VBUS) of all associated circuitry on the board. This value does NOT include the power consumption of a permanently attached peripheral if the hub is configured as a compound device.</p> <p>Note: The USB 2.0 Specification does not permit this value to exceed 100mA</p> <p>A value of 50 (decimal) indicates 100mA, which is the default value.</p>

Datasheet

4.3.1.16 Register 0Fh: Hub Controller Max Current For Bus Powered Operation

BIT NUMBER	BIT NAME	DESCRIPTION
7:0	HC_MAX_C_BP	Hub Controller Max Current Bus-Powered: Value in 2mA increments that the Hub consumes from an upstream port (VBUS) when operating as a bus-powered hub. This value will include the hub silicon along with the combined power consumption (from VBUS) of all associated circuitry on the board. This value will NOT include the power consumption of a permanently attached peripheral if the hub is configured as a compound device. A value of 50 (decimal) would indicate 100mA, which is the default value.

4.3.1.17 Register 10h: Power-On Time

BIT NUMBER	BIT NAME	DESCRIPTION
7:0	POWER_ON_TIME	Power On Time: The length of time that it takes (in 2 ms intervals) from the time the host initiated power-on sequence begins on a port until power is good on that port.

4.3.1.18 Register 11h: Language ID High

BIT NUMBER	BIT NAME	DESCRIPTION
7:0	LANG_ID_H	USB LANGUAGE ID (Upper 8 bits of a 16 bit ID field)

4.3.1.19 Register 12h: Language ID Low

BIT NUMBER	BIT NAME	DESCRIPTION
7:0	LANG_ID_L	USB LANGUAGE ID (Lower 8 bits of a 16 bit ID field)

4.3.1.20 Register 13h: Manufacturer String Length

BIT NUMBER	BIT NAME	DESCRIPTION
7:0	MFR_STR_LEN	Manufacturer String Length Maximum string length is 31 characters

4.3.1.21 Register 14h: Product String Length

BIT NUMBER	BIT NAME	DESCRIPTION
7:0	PRD_STR_LEN	Product String Length Maximum string length is 31 characters

4.3.1.22 Register 15h: Serial String Length

BIT NUMBER	BIT NAME	DESCRIPTION
7:0	SER_STR_LEN	Serial String Length Maximum string length is 31 characters

4.3.1.23 Register 16h-53h: Manufacturer String

BIT NUMBER	BIT NAME	DESCRIPTION
7:0	MFR_STR	Manufacturer String, UNICODE UTF-16LE per USB 2.0 Specification Maximum string length is 31 characters (62 bytes) Note: The String consists of individual 16 Bit UNICODE UTF-16LE characters. The Characters will be stored starting with the LSB at the least significant address and the MSB at the next 8-bit location (subsequent characters must be stored in sequential contiguous address in the same LSB, MSB manner). Some EEPROM programmers may transpose the MSB and LSB, thus reversing the Byte order. Please pay careful attention to the Byte ordering or your selected programming tools.

4.3.1.24 Register 54h-91h: Product String

BIT NUMBER	BIT NAME	DESCRIPTION
7:0	PRD_STR	Product String, UNICODE UTF-16LE per USB 2.0 Specification Maximum string length is 31 characters (62 bytes) Note: The String consists of individual 16 Bit UNICODE UTF-16LE characters. The Characters will be stored starting with the LSB at the least significant address and the MSB at the next 8-bit location (subsequent characters must be stored in sequential contiguous address in the same LSB, MSB manner). Some EEPROM programmers may transpose the MSB and LSB, thus reversing the Byte order. Please pay careful attention to the Byte ordering or your selected programming tools.

Datasheet

4.3.1.25 Register 92h-CFh: Serial String

BIT NUMBER	BIT NAME	DESCRIPTION
7:0	SER_STR	<p>Serial String, UNICODE UTF16LE per USB 2.0 Specification</p> <p>Maximum string length is 31 characters (62 bytes)</p> <p>Note: The String consists of individual 16 Bit UNICODE UTF-16LE characters. The Characters will be stored starting with the LSB at the least significant address and the MSB at the next 8-bit location (subsequent characters must be stored in sequential contiguous address in the same LSB, MSB manner). Some EEPROM programmers may transpose the MSB and LSB, thus reversing the Byte order. Please pay careful attention to the Byte ordering or your selected programming tools.</p>

4.3.1.26 Register F6h: Boost_Up

BIT NUMBER	BIT NAME	DESCRIPTION
7:2	Reserved	Reserved
1:0	BOOST_IOUT	<p>Upstream USB electrical signaling drive strength Boost Bit for Upstream Port.</p> <p>'00' = Normal electrical drive strength = No boost '01' = Elevated electrical drive strength = Low (approximately 4% boost) '10' = Elevated electrical drive strength = Medium (approximately 8% boost) '11' = Elevated electrical drive strength = High (approximately 12% boost)</p> <p>Note: "Boost" could result in non-USB Compliant parameters (one example would be Test J/K levels), the OEM should use a '00' value unless specific implementation issues require additional signal boosting to correct for degraded USB signalling levels.</p>

4.3.1.27 Register F8h: Boost_4:0

BIT NUMBER	BIT NAME	DESCRIPTION
7:6	BOOST_IOUT_4	Upstream USB electrical signaling drive strength Boost Bit for Downstream Port '4'. '00' = Normal electrical drive strength = No boost '01' = Elevated electrical drive strength = Low (approximately 4% boost) '10' = Elevated electrical drive strength = Medium (approximately 8% boost) '11' = Elevated electrical drive strength = High (approximately 12% boost) Note: "Boost" could result in non-USB Compliant parameters (one example would be Test J/K levels), the OEM should use a '00' value unless specific implementation issues require additional signal boosting to correct for degraded USB signalling levels.
5:4	BOOST_IOUT_3	Upstream USB electrical signaling drive strength Boost Bit for Downstream Port '3'. '00' = Normal electrical drive strength = No boost '01' = Elevated electrical drive strength = Low (approximately 4% boost) '10' = Elevated electrical drive strength = Medium (approximately 8% boost) '11' = Elevated electrical drive strength = High (approximately 12% boost) Note: "Boost" could result in non-USB Compliant parameters (one example would be Test J/K levels), the OEM should use a '00' value unless specific implementation issues require additional signal boosting to correct for degraded USB signalling levels.
3:2	BOOST_IOUT_2	Upstream USB electrical signaling drive strength Boost Bit for Downstream Port '2'. '00' = Normal electrical drive strength = No boost '01' = Elevated electrical drive strength = Low (approximately 4% boost) '10' = Elevated electrical drive strength = Medium (approximately 8% boost) '11' = Elevated electrical drive strength = High (approximately 12% boost) Note: "Boost" could result in non-USB Compliant parameters (one example would be Test J/K levels), the OEM should use a '00' value unless specific implementation issues require additional signal boosting to correct for degraded USB signalling levels.
1:0	BOOST_IOUT_1	Upstream USB electrical signaling drive strength Boost Bit for Downstream Port '1'. '00' = Normal electrical drive strength = No boost '01' = Elevated electrical drive strength = Low (approximately 4% boost) '10' = Elevated electrical drive strength = Medium (approximately 8% boost) '11' = Elevated electrical drive strength = High (approximately 12% boost) Note: "Boost" could result in non-USB Compliant parameters (one example would be Test J/K levels), the OEM should use a '00' value unless specific implementation issues require additional signal boosting to correct for degraded USB signalling levels.

Datasheet

4.3.1.28 Register FAh: Port Swap

BIT NUMBER	BIT NAME	DESCRIPTION
7:0	PRTSP	<p>Port Swap: Swaps the Upstream and Downstream USB DP and DM Pins for ease of board routing to devices and connectors.</p> <p>'0' = USB D+ functionality is associated with the DP pin and D- functionality is associated with the DM pin.</p> <p>'1' = USB D+ functionality is associated with the DM pin and D- functionality is associated with the DP pin.</p> <p>Bit 7= Reserved Bit 6= Reserved Bit 5= Reserved Bit 4= '1'; Port 4 DP/DM is Swapped. Bit 3= '1'; Port 3 DP/DM is Swapped. Bit 2= '1'; Port 2 DP/DM is Swapped. Bit 1= '1'; Port 1 DP/DM is Swapped. Bit 0= '1'; Upstream Port DP/DM is Swapped</p>

4.3.1.29 Register FBh: Port Remap 12

BIT NUMBER	BIT NAME	DESCRIPTION
------------	----------	-------------

7:0	PRTR12	<p>Port remap register for ports 1 & 2.</p> <p>When a hub is enumerated by a USB Host Controller, the hub is only permitted to report how many ports it has; the hub is not permitted to select a numerical range or assignment. The Host Controller will number the downstream ports of the hub starting with the number '1', up to the number of ports that the hub reported having.</p> <p>The host's port number is referred to as "Logical Port Number" and the physical port on the hub is the "Physical Port Number". When remapping mode is enabled (see PRTMAP_EN in Register 08h: Configuration Data Byte 3) the hub's downstream port numbers can be remapped to different logical port numbers (assigned by the host).</p> <p>Note: The OEM must ensure that Contiguous Logical Port Numbers are used, starting from #1 up to the maximum number of enabled ports; this ensures that the hub's ports are numbered in accordance with the way a Host will communicate with the ports.</p>
Table 4.3 Port Remap Register for Ports 1 & 2		
Bit [7:4]	'0000'	Physical Port 2 is Disabled
	'0001'	Physical Port 2 is mapped to Logical Port 1
	'0010'	Physical Port 2 is mapped to Logical Port 2
	'0011'	Physical Port 2 is mapped to Logical Port 3
	'0100'	Physical Port 2 is mapped to Logical Port 4
	'0101' to '1111'	Illegal; Do Not Use
Bit [3:0]	'0000'	Physical Port 1 is Disabled
	'0001'	Physical Port 1 is mapped to Logical Port 1
	'0010'	Physical Port 1 is mapped to Logical Port 2
	'0011'	Physical Port 1 is mapped to Logical Port 3
	'0100'	Physical Port 1 is mapped to Logical Port 4
	'0101' to '1111'	Illegal; Do Not Use

4.3.1.30 Register FCh: Port Remap 34

BIT NUMBER	BIT NAME	DESCRIPTION
------------	----------	-------------

Datasheet

7:0	PRTR34	<p>Port remap register for ports 3 & 4.</p> <p>When a hub is enumerated by a USB Host Controller, the hub is only permitted to report how many ports it has; the hub is not permitted to select a numerical range or assignment. The Host Controller will number the downstream ports of the hub starting with the number '1', up to the number of ports that the hub reported having.</p> <p>The host's port number is referred to as "Logical Port Number" and the physical port on the hub is the "Physical Port Number". When remapping mode is enabled (see PRTMAP_EN in Register 08h: Configuration Data Byte 3) the hub's downstream port numbers can be remapped to different logical port numbers (assigned by the host).</p> <p>Note: The OEM must ensure that Contiguous Logical Port Numbers are used, starting from #1 up to the maximum number of enabled ports; this ensures that the hub's ports are numbered in accordance with the way a Host will communicate with the ports.</p> <p style="text-align: center;">Table 4.4 Port Remap Register for Ports 3 & 4</p> <table border="1" data-bbox="587 760 1429 1512"> <tr> <td data-bbox="587 760 787 1113" rowspan="6">Bit [7:4]</td> <td data-bbox="787 760 889 808">'0000'</td> <td data-bbox="889 760 1429 808">Physical Port 4 is Disabled</td> </tr> <tr> <td data-bbox="787 808 889 856">'0001'</td> <td data-bbox="889 808 1429 856">Physical Port 4 is mapped to Logical Port 1</td> </tr> <tr> <td data-bbox="787 856 889 905">'0010'</td> <td data-bbox="889 856 1429 905">Physical Port 4 is mapped to Logical Port 2</td> </tr> <tr> <td data-bbox="787 905 889 953">'0011'</td> <td data-bbox="889 905 1429 953">Physical Port 4 is mapped to Logical Port 3</td> </tr> <tr> <td data-bbox="787 953 889 1001">'0100'</td> <td data-bbox="889 953 1429 1001">Physical Port 4 is mapped to Logical Port 4</td> </tr> <tr> <td data-bbox="787 1001 889 1113">'0101' to '1111'</td> <td data-bbox="889 1001 1429 1113">Illegal; Do Not Use</td> </tr> <tr> <td data-bbox="587 1113 787 1512" rowspan="6">Bit [3:0]</td> <td data-bbox="787 1113 889 1161">'0000'</td> <td data-bbox="889 1113 1429 1161">Physical Port 3 is Disabled</td> </tr> <tr> <td data-bbox="787 1161 889 1209">'0001'</td> <td data-bbox="889 1161 1429 1209">Physical Port 3 is mapped to Logical Port 1</td> </tr> <tr> <td data-bbox="787 1209 889 1257">'0010'</td> <td data-bbox="889 1209 1429 1257">Physical Port 3 is mapped to Logical Port 2</td> </tr> <tr> <td data-bbox="787 1257 889 1306">'0011'</td> <td data-bbox="889 1257 1429 1306">Physical Port 3 is mapped to Logical Port 3</td> </tr> <tr> <td data-bbox="787 1306 889 1354">'0100'</td> <td data-bbox="889 1306 1429 1354">Physical Port 3 is mapped to Logical Port 4</td> </tr> <tr> <td data-bbox="787 1354 889 1512">'0101' to '1111'</td> <td data-bbox="889 1354 1429 1512">Illegal; Do Not Use</td> </tr> </table>	Bit [7:4]	'0000'	Physical Port 4 is Disabled	'0001'	Physical Port 4 is mapped to Logical Port 1	'0010'	Physical Port 4 is mapped to Logical Port 2	'0011'	Physical Port 4 is mapped to Logical Port 3	'0100'	Physical Port 4 is mapped to Logical Port 4	'0101' to '1111'	Illegal; Do Not Use	Bit [3:0]	'0000'	Physical Port 3 is Disabled	'0001'	Physical Port 3 is mapped to Logical Port 1	'0010'	Physical Port 3 is mapped to Logical Port 2	'0011'	Physical Port 3 is mapped to Logical Port 3	'0100'	Physical Port 3 is mapped to Logical Port 4	'0101' to '1111'	Illegal; Do Not Use
Bit [7:4]	'0000'	Physical Port 4 is Disabled																										
	'0001'	Physical Port 4 is mapped to Logical Port 1																										
	'0010'	Physical Port 4 is mapped to Logical Port 2																										
	'0011'	Physical Port 4 is mapped to Logical Port 3																										
	'0100'	Physical Port 4 is mapped to Logical Port 4																										
	'0101' to '1111'	Illegal; Do Not Use																										
Bit [3:0]	'0000'	Physical Port 3 is Disabled																										
	'0001'	Physical Port 3 is mapped to Logical Port 1																										
	'0010'	Physical Port 3 is mapped to Logical Port 2																										
	'0011'	Physical Port 3 is mapped to Logical Port 3																										
	'0100'	Physical Port 3 is mapped to Logical Port 4																										
	'0101' to '1111'	Illegal; Do Not Use																										

4.3.1.31 Register FFh: Status/Command

BIT NUMBER	BIT NAME	DESCRIPTION
7:3	Reserved	Reserved
2	INTF_PW_DN	SMBus Interface Power Down '0' = Interface is active '1' = Interface power down after ACK has completed
1	RESET	Reset the SMBus Interface and internal memory back to RESET_N assertion default settings. '0' = Normal Run/Idle State '1' = Force a reset of registers to their default state
0	USB_ATTACH	USB Attach (and write protect) '0' = SMBus slave interface is active '1' = Hub will signal a USB attach event to an upstream device, and the internal memory (address range 00h-FEh) is "write-protected" to prevent unintentional data corruption.

4.3.2 I2C EEPROM

The I2C EEPROM interface implements a subset of the I2C Master Specification (Please refer to the Philips Semiconductor Standard I2C-Bus Specification for details on I2C bus protocols). The Hub's I2C EEPROM interface is designed to attach to a single "dedicated" I2C EEPROM, and it conforms to the Standard-mode I2C Specification (100kbit/s transfer rate and 7-bit addressing) for protocol and electrical compatibility.

Note: Extensions to the I2C Specification are not supported.

The Hub acts as the master and generates the serial clock SCL, controls the bus access (determines which device acts as the transmitter and which device acts as the receiver), and generates the START and STOP conditions.

4.3.2.1 Implementation Characteristics

The Hub will only access an EEPROM using the Sequential Read Protocol.

4.3.2.2 Pull-Up Resistor

The Circuit board designer is required to place external pull-up resistors (10KΩ recommended) on the SDA/SMBDATA & SCL/SMBCLK/CFG_SELO lines (per SMBus 1.0 Specification, and EEPROM manufacturer guidelines) to Vcc in order to assure proper operation.

4.3.2.3 I2C EEPROM Slave Address

Slave address is 1010000.

Note: 10-bit addressing is NOT supported.

4.3.3 In-Circuit EEPROM Programming

The EEPROM can be programmed via ATE by pulling RESET_N low (which tri-states the Hub's EEPROM interface and allows an external source to program the EEPROM).

4.4 SMBus Slave Interface

Instead of loading User-Defined Descriptor data from an external EEPROM, the SMSC Hub can be configured to receive a code load from an external processor via an SMBus interface. The SMBus interface shares the same pins as the EEPROM interface; if CFG_SEL1 & CFG_SEL0 activates the SMBus interface, external EEPROM support is no longer available (and the user-defined descriptor data must be downloaded via the SMBus). Due to system issues, the SMSC Hub waits indefinitely for the SMBus code load to complete and only “appears” as a newly connected device on USB after the code load is complete.

The Hub’s SMBus implementation is a subset of the SMBus interface to the host. The device is a *slave-only* SMBus device. The implementation in the device is a subset of SMBus since it only supports two protocols.

The Write Block and Read Block protocols are the only valid SMBus protocols for the Hub. The Hub responds to other protocols as described in [Section 4.4.2, "Invalid Protocol Response Behavior," on page 36](#). Reference the System Management Bus Specification, Rev 1.0.

The SMBus interface is used to read and write the registers in the device. The register set is shown in [Section 4.3.1, "Internal Register Set \(Common to EEPROM and SMBus\)," on page 19](#).

4.4.1 Bus Protocols

Typical Write Block and Read Block protocols are shown below. Register accesses are performed using 7-bit slave addressing, an 8-bit register address field, and an 8-bit data field. The shading indicates the Hub driving data on the SMBDATA line; otherwise, host data is on the SDA/SMBDATA line.

The slave address is the unique SMBus Interface Address for the Hub that identifies it on SMBus. The register address field is the internal address of the register to be accessed. The register data field is the data that the host is attempting to write to the register or the contents of the register that the host is attempting to read.

Note: Data bytes are transferred MSB first (msb first).

4.4.1.1 Block Read/Write

The Block Write begins with a slave address and a write condition. After the command code, the host issues a byte count which describes how many more bytes will follow in the message. If a slave had 20 bytes to send, the first byte would be the number 20 (14h), followed by the 20 bytes of data. The byte count may not be 0. A Block Read or Write is allowed to transfer a maximum of 32 data bytes.

Note: For the following SMBus tables:

Denotes Master-to-Slave Denotes Slave-to-Master

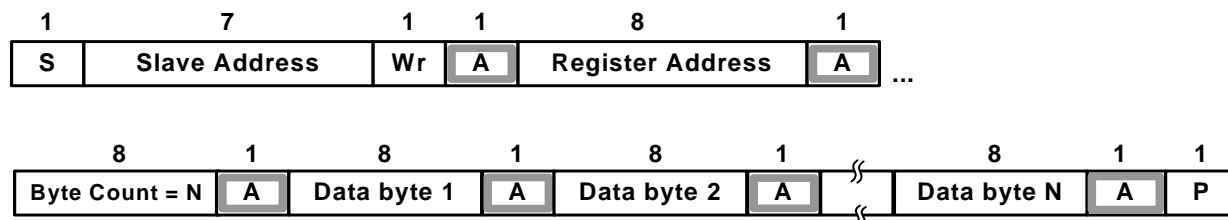

Block Write

Figure 4.1 Block Write

Block Read

A Block Read differs from a block write in that the repeated start condition exists to satisfy the I2C specification's requirement for a change in the transfer direction.

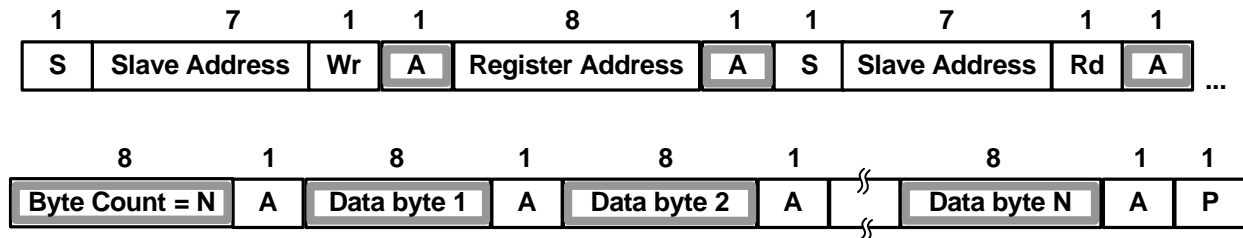
Block Read
Figure 4.2 Block Read

4.4.2 Invalid Protocol Response Behavior

Registers that are accessed with an invalid protocol are not updated. A register is only updated following a valid protocol. The only valid protocols are Write Block and Read Block, which are described above.

The Hub only responds to the hardware selected Slave Address.

Attempting to communicate with the Hub over SMBus with an invalid slave address or invalid protocol results in no response, and the SMBus Slave Interface returns to the idle state.

The only valid registers that are accessible by the SMBus slave address are the registers defined in the Registers Section. See [Section 4.4.3](#) for the response to undefined registers.

4.4.3 General Call Address Response

The Hub does not respond to a general call address of 0000_000b.

4.4.4 Slave Device Time-Out

According to the SMBus Specification, V1.0 devices in a transfer can abort the transfer in progress and release the bus when any single clock low interval exceeds 25ms ($T_{\text{TIMEOUT, MIN}}$). Devices that have detected this condition must reset their communication and be able to receive a new START condition no later than 35ms ($T_{\text{TIMEOUT, MAX}}$).

Note: Some simple devices do not contain a clock low drive circuit; this simple kind of device typically resets its communications port after a start or stop condition. The Slave Device Time-Out must be implemented.

4.4.5 Stretching the SCLK Signal

The Hub supports stretching of the SCLK by other devices on the SMBus. The Hub does not stretch the SCLK.

4.4.6 SMBus Timing

The SMBus Slave Interface complies with the SMBus AC Timing Specification. See the SMBus timing in the "Timing Diagram" section.

Datasheet

4.4.7 Bus Reset Sequence

The SMBus Slave Interface resets and returns to the idle state upon a START field followed immediately by a STOP field.

4.4.8 SMBus Alert Response Address

The SMBALERT# signal is not supported by the Hub.

4.4.8.1 Undefined Registers

The registers shown in [Table 4.2](#) are the defined registers in the Hub. Reads to undefined registers return 00h. Writes to undefined registers have no effect and do not return an error.

4.4.8.2 Reserved Registers

Unless otherwise instructed, only a '0' may be written to all reserved registers or bits.

4.5 Default Configuration Option:

The SMSC Hub can be configured via its internal default configuration. (please see [Section 4.3.1, "Internal Register Set \(Common to EEPROM and SMBus\)"](#) for specific details on how to enable default configuration.)

Please refer to [Table 4.2](#) for the internal default values that are loaded when this option is selected.

4.6 Default Strapping Options:

The USB2514 can be configured via a combination of internal default values and pin strap options. Please see [Table 3.1](#) and [Table 3.2](#) for specific details on how to enable the default/pin-strap configuration option.

The strapping option pins only cover a limited sub-set of the configuration options. The internal default values will be used for the bits & registers that are not controlled by a strapping option pin. Please refer to [Table 4.2](#) for the internal default values that are loaded when this option is selected.

The Amber and Green LED pins are sampled after RESET_N negation, and the logic values are used to configure the hub if the internal default configuration mode is selected. The implementation shown below (see [Figure 4.3](#)) shows a recommended passive scheme. When a pin is configured with a "Strap High" configuration, the LED functions with active low signalling, and the PAD will "sink" the current from the external supply. When a pin is configured with a "Strap Low" configuration, the LED functions with active high signalling, and the PAD will "source" the current to the external LED.

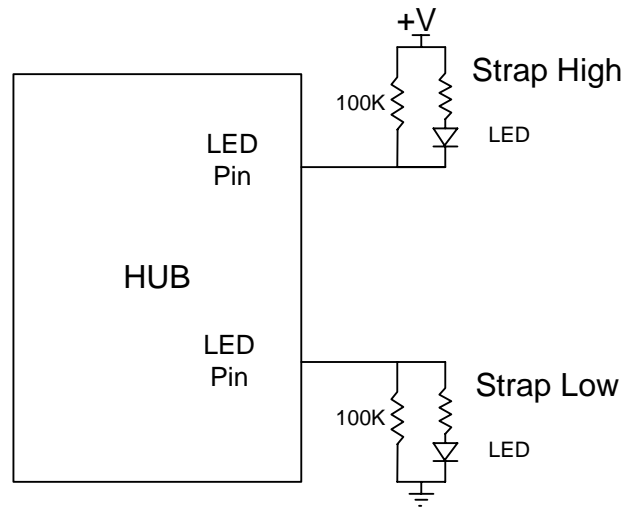
Figure 4.3 LED Strapping Option

4.7 Reset

There are two different resets that the Hub experiences. One is a hardware reset (either from the internal POR reset circuit or via the RESET_N pin) and the second is a USB Bus Reset.

4.7.1 Internal POR Hardware Reset

All reset timing parameters are guaranteed by design.

4.7.2 External Hardware RESET_N

A valid hardware reset is defined as assertion of RESET_N for a minimum of 1 μ s after all power supplies are within operating range. While reset is asserted, the Hub (and its associated external circuitry) consumes less than 500 μ A of current from the upstream USB power source.

Assertion of RESET_N (external pin) causes the following:

1. All downstream ports are disabled, and PRTPOWER power to downstream devices is removed.
2. The PHYs are disabled, and the differential pairs will be in a high-impedance state.
3. All transactions immediately terminate; no states are saved.
4. All internal registers return to the default state (in most cases, 00(h)).
5. The external crystal oscillator is halted.
6. The PLL is halted.
7. LED indicators are disabled.

The Hub is "operational" 500 μ s after RESET_N is negated.

Once operational, the Hub immediately reads OEM-specific data from the external EEPROM (if the SMBus option is not disabled).

Datasheet

4.7.2.1 RESET_N for Strapping Option Configuration

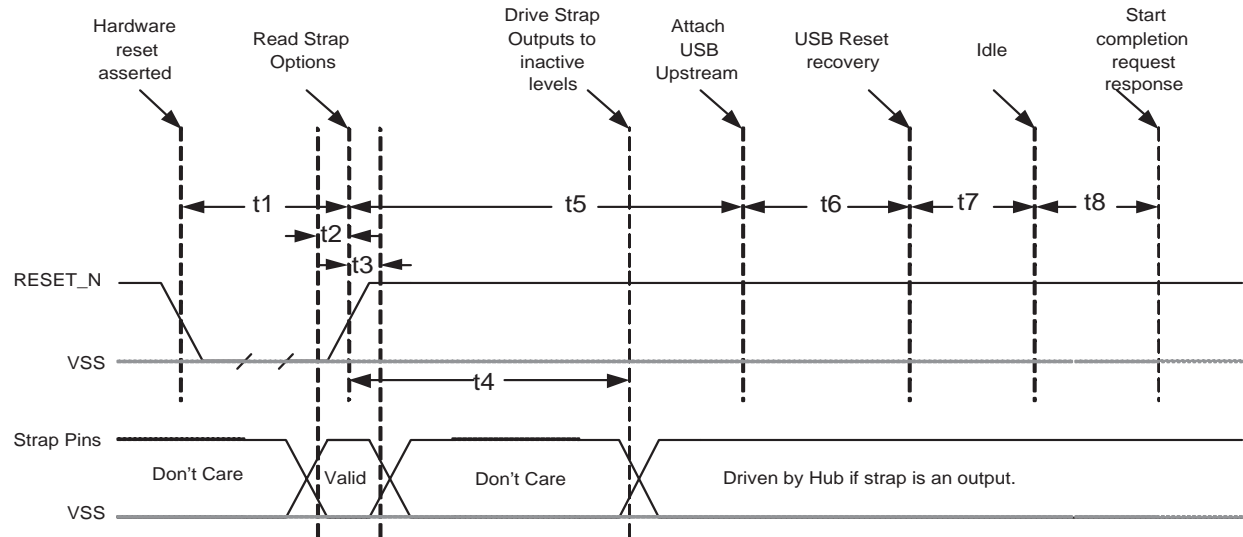

Figure 4.4 Reset_N Timing for Default/Strap Option Mode

Table 4.5 Reset_N Timing for Default/Strap Option Mode

NAME	DESCRIPTION	MIN	TYP	MAX	UNITS
t1	RESET_N Asserted.	1			μsec
t2	Strap Setup Time	16.7			nsec
t3	Strap Hold Time.	16.7		1400	nsec
t4	hub outputs driven to inactive logic states		1.5	2	μsec
t5	USB Attach (See Note).			100	msec
t6	Host acknowledges attach and signals USB Reset.	100			msec
t7	USB Idle.		undefined		msec
t8	Completion time for requests (with or without data stage).			5	msec

Notes:

- When in Bus-Powered mode, the Hub and its associated circuitry must not consume more than 100mA from the upstream USB power source during t1+t5.
- All Power Supplies must have reached the operating levels mandated in [Chapter 5, DC Parameters](#), prior to (or coincident with) the assertion of RESET_N.

4.7.2.2 RESET_N for EEPROM Configuration

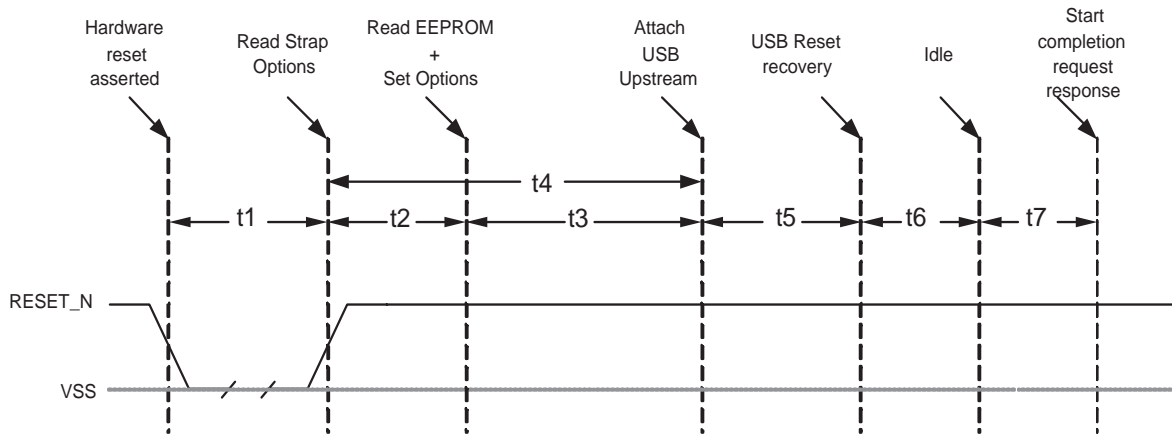

Figure 4.5 Reset_N Timing for EEPROM Mode

Table 4.6 Reset_N Timing for EEPROM Mode

NAME	DESCRIPTION	MIN	TYP	MAX	UNITS
t1	RESET_N Asserted.	1			μsec
t2	Hub Recovery/Stabilization.			500	μsec
t3	EEPROM Read / Hub Config.		2.0	99.5	msec
t4	USB Attach (See Note).			100	msec
t5	Host acknowledges attach and signals USB Reset.	100			msec
t6	USB Idle.		undefined		msec
t7	Completion time for requests (with or without data stage).			5	msec

Notes:

- When in Bus-Powered mode, the Hub and its associated circuitry must not consume more than 100mA from the upstream USB power source during t4+t5+t6+t7.
- All Power Supplies must have reached the operating levels mandated in [Chapter 5, DC Parameters](#), prior to (or coincident with) the assertion of RESET_N.

4.7.2.3 RESET_N for SMBus Slave Configuration

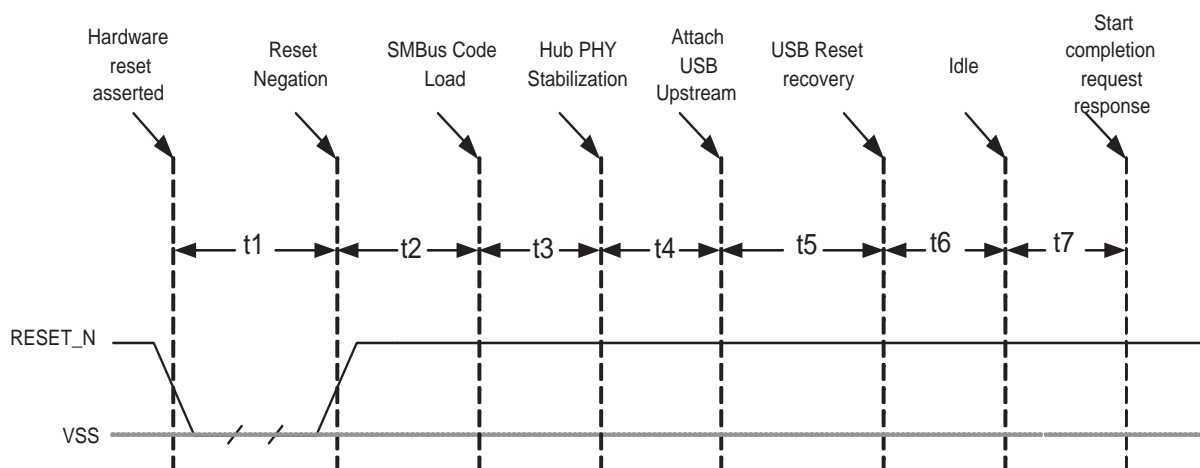

Figure 4.6 Reset_N Timing for SMBus Mode

Table 4.7 Reset_N Timing for SMBus Mode

NAME	DESCRIPTION	MIN	TYP	MAX	UNITS
t1	RESET_N Asserted.	1			μsec
t2	Hub Recovery/Stabilization.			500	μsec
t3	SMBus Code Load (See Note).		250	300	msec
t4	Hub Configuration and USB Attach.			100	msec
t5	Host acknowledges attach and signals USB Reset.	100			msec
t6	USB Idle.		Undefined		msec
t7	Completion time for requests (with or without data stage).			5	msec

Notes:

- For Bus-Powered configurations, the 99.5ms (MAX) is required, and the Hub and its associated circuitry must not consume more than 100mA from the upstream USB power source during t2+t3+t4+t5+t6+t7. For Self-Powered configurations, t3 MAX is not applicable and the time to load the configuration is determined by the external SMBus host.
- All Power Supplies must have reached the operating levels mandated in [Chapter 5, DC Parameters](#), prior to (or coincident with) the assertion of RESET_N.

4.7.3 USB Bus Reset

In response to the upstream port signaling a reset to the Hub, the Hub does the following:

Note: The Hub does not propagate the upstream USB reset to downstream devices.

- Sets default address to 0.
- Sets configuration to: Unconfigured.
- Negates PRTPOWER[4:1] to all downstream ports.
- Clears all TT buffers.

5. Moves device from suspended to active (if suspended).
6. Complies with Section 11.10 of the USB 2.0 Specification for behavior after completion of the reset sequence.

The Host then configures the Hub and the Hub's downstream port devices in accordance with the USB Specification.

Chapter 5 DC Parameters

5.1 Maximum Guaranteed Ratings

PARAMETER	SYMBOL	MIN	MAX	UNITS	COMMENTS
Storage Temperature	T_A	-55	150	°C	
Lead Temperature			325	°C	Soldering < 10 seconds
1.8V supply voltage	$V_{DDA18PLL}$, V_{DD18}		2.5	V	
3.3V supply voltage	V_{DDA33} , $V_{DD33PLL}$, V_{DD33} , V_{DD33CR}		4.6	V	
Voltage on any I/O pin		-0.5	5.5	V	
Voltage on XTAL1		-0.5	4.0	V	
Voltage on XTAL2		-0.5	3.6	V	

Note: Stresses above the specified parameters could cause permanent damage to the device. This is a stress rating only and functional operation of the device at any condition above those indicated in the operation sections of this specification is not implied. When powering this device from laboratory or system power supplies, it is important that the Absolute Maximum Ratings not be exceeded or device failure can result. Some power supplies exhibit voltage spikes on their outputs when the AC power is switched on or off. In addition, voltage transients on the AC power line may appear on the DC output. When this possibility exists, it is suggested that a clamp circuit be used.

5.2 Recommended Operating Conditions

PARAMETER	SYMBOL	MIN	MAX	UNITS	COMMENTS
Operating Temperature	T_A	0	70	°C	
1.8V supply voltage	$V_{DDA18PLL}$, V_{DD18}	1.62	1.98	V	
3.3V supply voltage	V_{DDA33} , $V_{DDA33PLL}$, V_{DD33} , V_{DD33CR}	3.0	3.6	V	
Voltage on any I/O pin		-0.3	5.5	V	If any 3.3V supply voltage drops below 3.0V, then the MAX becomes: (3.3V supply voltage) + 0.5

PARAMETER	SYMBOL	MIN	MAX	UNITS	COMMENTS
Voltage on XTAL1		-0.3	V_{DDA33}	V	
Voltage on XTAL2		-0.3	V_{DD18}	V	

Table 5.1 DC Electrical Characteristics

PARAMETER	SYMBOL	MIN	TYP	MAX	UNITS	COMMENTS
I, IS Type Input Buffer						
Low Input Level	V_{ILI}			0.8	V	TTL Levels
High Input Level	V_{IHI}	2.0			V	
Input Leakage	I_{IL}	-10		+10	uA	$V_{IN} = 0$ to V_{DD33}
Hysteresis ('IS' Only)	V_{HYSI}	250		350	mV	
Input Buffer with Pull-Up (IPU)						
Low Input Level	V_{ILI}			0.8	V	TTL Levels
High Input Level	V_{IHI}	2.0			V	
Low Input Leakage	I_{ILL}	+35		+90	uA	$V_{IN} = 0$
High Input Leakage	I_{IHL}	-10		+10	uA	$V_{IN} = V_{DD33}$
Input Buffer with Pull-Down (IPD)						
Low Input Level	V_{ILI}			0.8	V	TTL Levels
High Input Level	V_{IHI}	2.0			V	
Low Input Leakage	I_{ILL}	+10		-10	uA	$V_{IN} = 0$
High Input Leakage	I_{IHL}	-35		-90	uA	$V_{IN} = V_{DD33}$
ICLK Input Buffer						
Low Input Level	V_{ILCK}			0.5	V	
High Input Level	V_{IHCK}	1.4			V	
Input Leakage	I_{IL}	-10		+10	uA	$V_{IN} = 0$ to V_{DD33}
O12, I/O12 & I/OSD12 Type Buffer						
Low Output Level	V_{OL}			0.4	V	$I_{OL} = 12\text{mA}$ @ $V_{DD33} = 3.3\text{V}$
High Output Level	V_{OH}	2.4			V	$I_{OH} = -12\text{mA}$ @ $V_{DD33} = 3.3\text{V}$
Output Leakage	I_{OL}	-10		+10	uA	$V_{IN} = 0$ to V_{DD33}
Hysteresis ('SD' pad only)	V_{HYSC}	250		350	mV	(Note 5.1)

Table 5.1 DC Electrical Characteristics (continued)

PARAMETER	SYMBOL	MIN	TYP	MAX	UNITS	COMMENTS
IO-U (Note 5.2)						
Supply Current Unconfigured						
High-Speed Host	$I_{CCINTHS}$		95	105	mA	
Full-Speed Host	$I_{CCINTFS}$		80	90	mA	
Supply Current Configured (High-Speed Host)						All supplies combined
1 Port HS, 1 Port LS/FS	I_{HCH1C1}		150	170	mA	
2 Ports @ LS/FS	I_{HCC2}		150	160	mA	
2 Ports @ HS	I_{HCH2}		160	275	mA	
3 Ports @ HS	I_{HCH3}		170	290	mA	
4 Ports @ HS	I_{HCH4}		175	305	mA	
Supply Current Configured (Full-Speed Host)						All supplies combined
1 Port	I_{FCC1}		140	150	mA	
2 Ports	I_{FCC2}		140	150	mA	
3 Ports	I_{FCC3}		140	150	mA	
4 Ports	I_{FCC4}		140	150	mA	
Supply Current Suspend	I_{CSBY}		310	420	μ A	All supplies combined
Supply Current Reset	I_{CRST}		100	275	μ A	All supplies combined

Note 5.1 Output leakage is measured with the current pins in high impedance.

Note 5.2 See USB 2.0 Specification for USB DC electrical characteristics.

CAPACITANCE $T_A = 25^\circ\text{C}$; $f_c = 1\text{MHz}$; $V_{DD18}, V_{DDPLL} = 1.8\text{V}$

Table 5.2 Pin Capacitance

PARAMETER	SYMBOL	LIMITS			UNIT	TEST CONDITION
		MIN	TYP	MAX		
Clock Input Capacitance	C_{XTAL}			2	pF	All pins except USB pins (and pins under test tied to AC ground)
Input Capacitance	C_{IN}			10	pF	
Output Capacitance	C_{OUT}			20	pF	

Chapter 6 AC Specifications

6.1 Oscillator/Clock

Crystal: Parallel Resonant, Fundamental Mode, 24 MHz \pm 350ppm.

External Clock: 50% Duty cycle \pm 10%, 24/48 MHz \pm 350ppm, Jitter < 100ps rms.

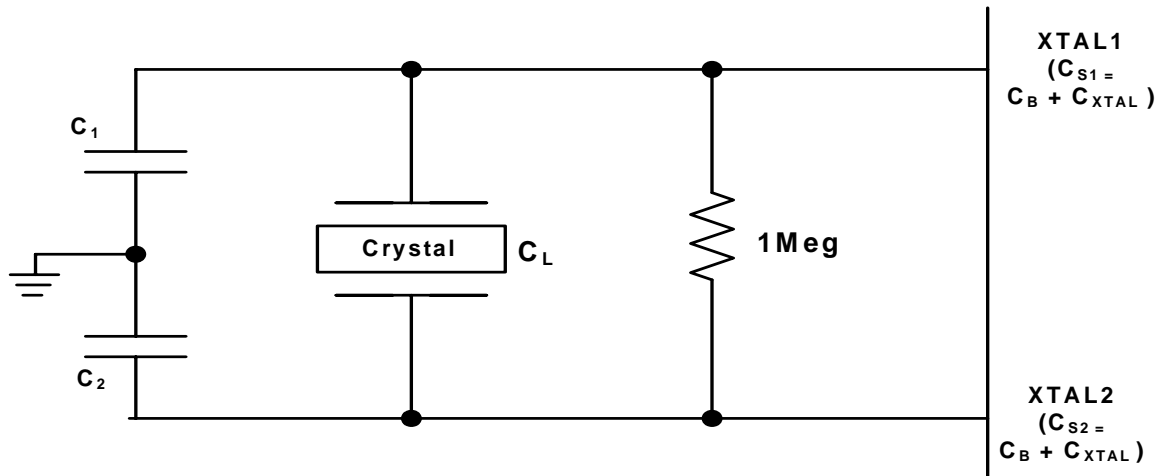

Figure 6.1 Typical Crystal Circuit

Note: C_B equals total board/trace capacitance.

$$\frac{(C_1 + C_{S1}) \times (C_2 + C_{S2})}{(C_1 + C_{S1} + C_2 + C_{S2})} = C_L$$

Figure 6.2 Formula to find value of C_1 and C_2

6.1.1 SMBus Interface:

The SMSC Hub conforms to all voltage, power, and timing characteristics and specifications as set forth in the SMBus 1.0 Specification for Slave-Only devices (except as noted in [Section 4.4, "SMBus Slave Interface"](#)).

6.1.2 I2C EEPROM:

Frequency is fixed at 58.6KHz \pm 20%.

6.1.3 USB 2.0

The SMSC Hub conforms to all voltage, power, and timing characteristics and specifications as set forth in the USB 2.0 Specification. Please refer to the USB 2.0 Specification for more information.

Chapter 7 Package Outlines

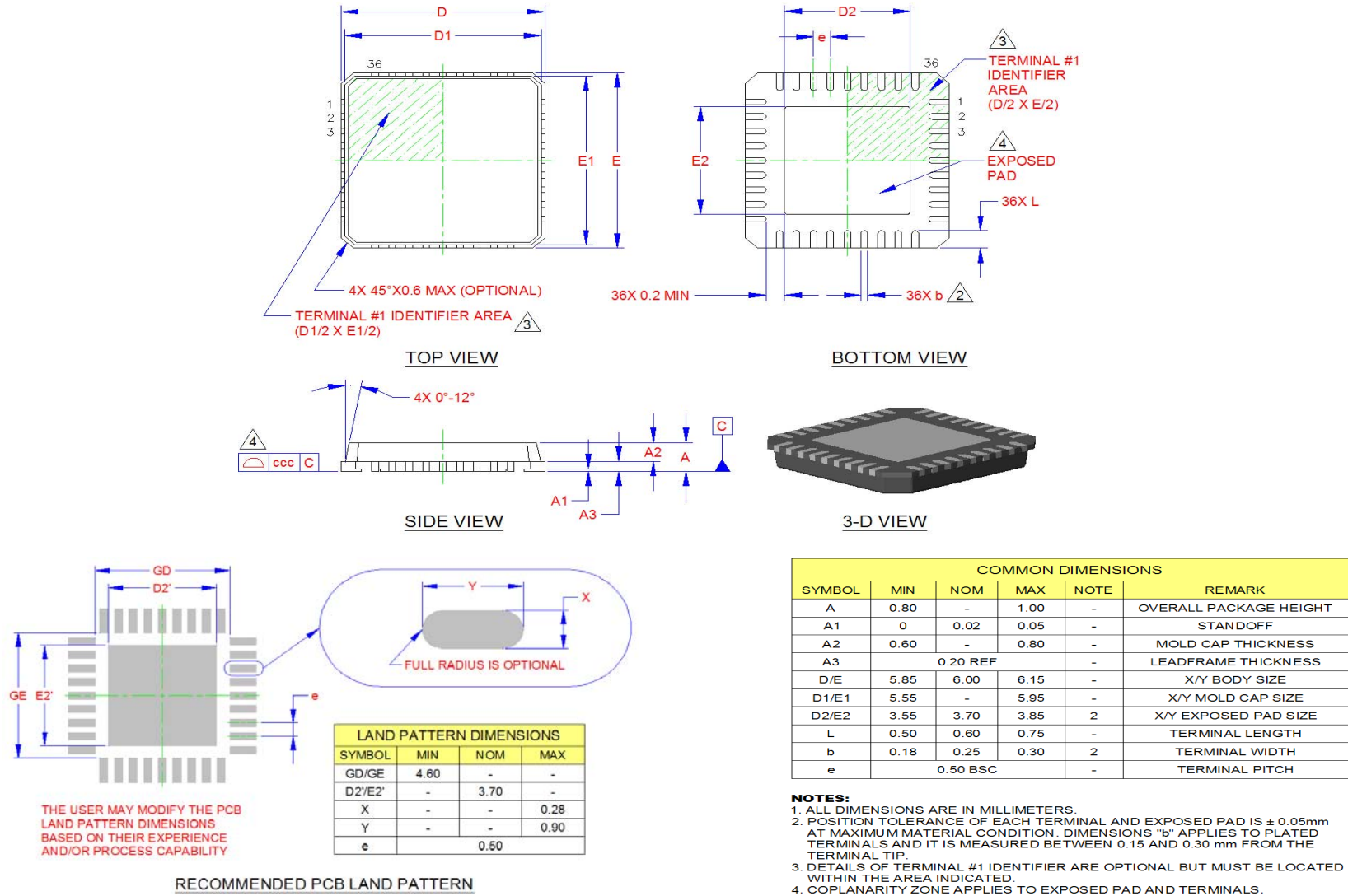

Figure 7.1 36-Pin QFN, 6x6mm Body, 0.5mm Pitch

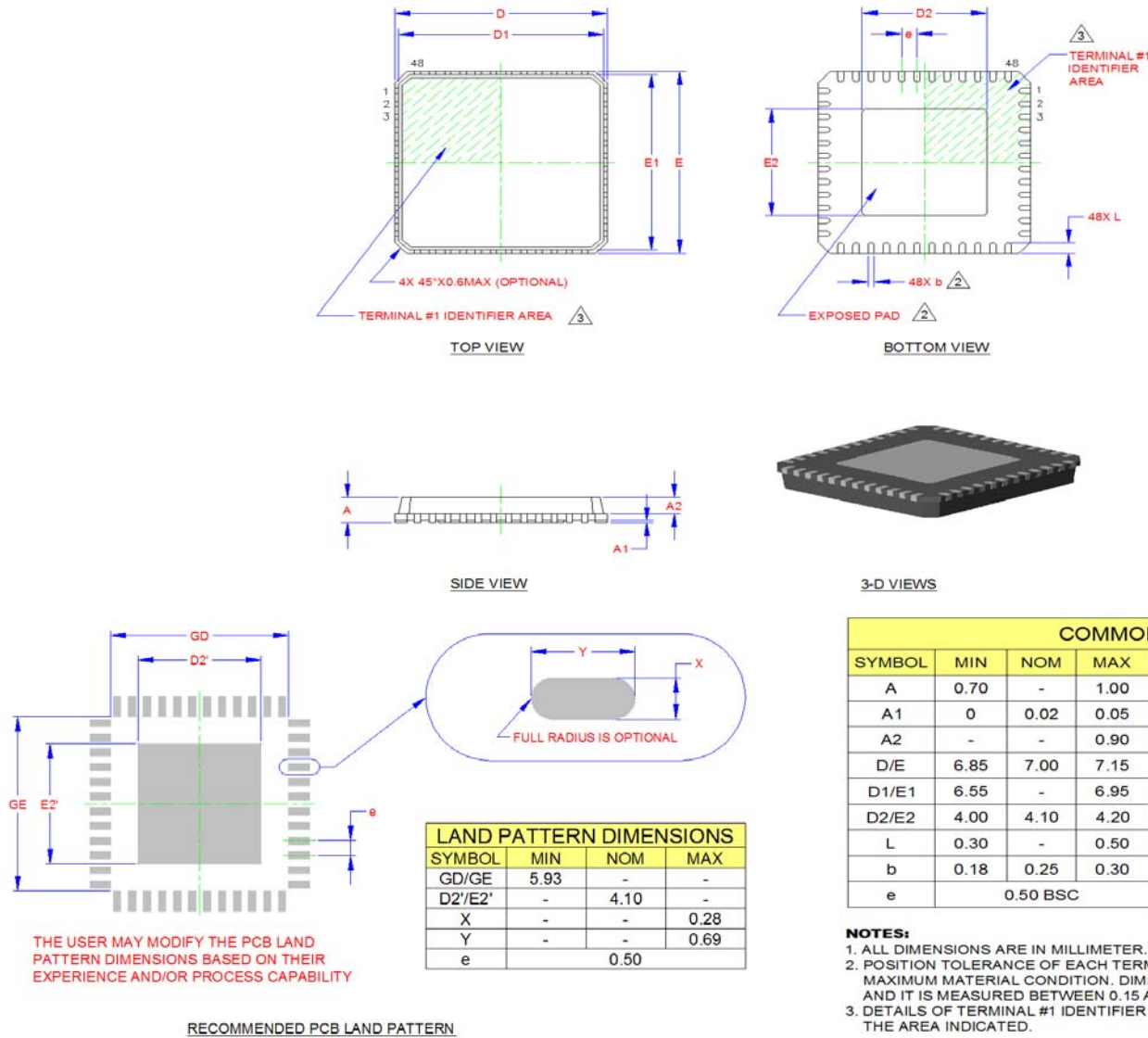

Figure 7.2 48-Pin QFN, 7x7mm Body, 0.5mm Pitch

Mouser Electronics

Authorized Distributor

Click to View Pricing, Inventory, Delivery & Lifecycle Information:

[Microchip:](#)

[USB2514-HZH](#) [USB2514I-AEZG](#) [USB2514I-HZH](#) [USB2514-AEZG-TR](#)



Стандарт Электрон Связь

Мы молодая и активно развивающаяся компания в области поставок электронных компонентов. Мы поставляем электронные компоненты отечественного и импортного производства напрямую от производителей и с крупнейших складов мира.

Благодаря сотрудничеству с мировыми поставщиками мы осуществляем комплексные и плановые поставки широчайшего спектра электронных компонентов.

Собственная эффективная логистика и склад в обеспечивает надежную поставку продукции в точно указанные сроки по всей России.

Мы осуществляем техническую поддержку нашим клиентам и предпродажную проверку качества продукции. На все поставляемые продукты мы предоставляем гарантию .

Осуществляем поставки продукции под контролем ВП МО РФ на предприятия военно-промышленного комплекса России , а также работаем в рамках 275 ФЗ с открытием отдельных счетов в уполномоченном банке. Система менеджмента качества компании соответствует требованиям ГОСТ ISO 9001.

Минимальные сроки поставки, гибкие цены, неограниченный ассортимент и индивидуальный подход к клиентам являются основой для выстраивания долгосрочного и эффективного сотрудничества с предприятиями радиоэлектронной промышленности, предприятиями ВПК и научно-исследовательскими институтами России.

С нами вы становитесь еще успешнее!

Наши контакты:

Телефон: +7 812 627 14 35

Электронная почта: sales@st-electron.ru

Адрес: 198099, Санкт-Петербург,
Промышленная ул, дом № 19, литера Н,
помещение 100-Н Офис 331