

# RF Power LDMOS Transistors

## High Ruggedness N-Channel Enhancement-Mode Lateral MOSFETs

Designed for mobile two-way radio applications with frequencies from 764 to 941 MHz. The high gain, ruggedness and broadband performance of these devices make them ideal for large-signal, common source amplifier applications in mobile radio equipment.

### Narrowband Performance (13.6 Vdc, I<sub>DQ</sub> = 500 mA, T<sub>A</sub> = 25°C, CW)

Frequency (MHz)	G <sub>ps</sub> (dB)	η <sub>D</sub> (%)	P <sub>1dB</sub> (W)
764	18.0	74.1	32
870	17.2	71.0	31
941	15.7	68.1	31

### 800 MHz Broadband Performance (13.6 Vdc, I<sub>DQ</sub> = 100 mA, T<sub>A</sub> = 25°C, CW)

Frequency (MHz)	G <sub>ps</sub> (dB)	η <sub>D</sub> (%)	P <sub>1dB</sub> (W)
760	15.7	62.0	44
820	15.7	63.0	37
870	15.5	61.0	36

### Load Mismatch/Ruggedness

Frequency (MHz)	Signal Type	VSWR	P <sub>in</sub> (W)	Test Voltage	Result
870 (1)	CW	>65:1 at all Phase Angles	1.2 (3 dB Overdrive)	17	No Device Degradation
870 (2)			2.0 (3 dB Overdrive)		

1. Measured in 870 MHz narrowband test circuit.
2. Measured in 760-870 MHz broadband reference circuit.

### Features

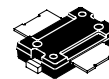
- Characterized for Operation from 764 to 941 MHz
- Unmatched Input and Output Allowing Wide Frequency Range Utilization
- Integrated ESD Protection
- Integrated Stability Enhancements
- Wideband — Full Power Across the Band (764–870 MHz)
- 225°C Capable Plastic Package
- Exceptional Thermal Performance
- High Linearity for: TETRA, SSB, LTE
- Cost-effective Over-molded Plastic Packaging
- In Tape and Reel. R1 Suffix = 500 Units, 24 mm Tape Width, 13 inch Reel.

### Typical Applications

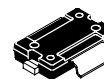
- Output Stage 800 MHz Trunking Band Mobile Radio
- Output Stage 900 MHz Trunking Band Mobile Radio

**AFT09MS031NR1**  
**AFT09MS031GNR1**

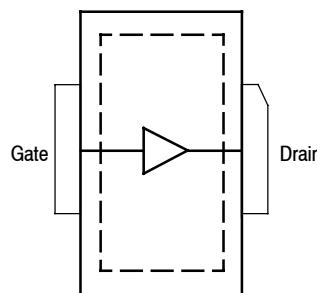
**764-941 MHz, 31 W, 13.6 V**  
**WIDEBAND**  
**RF POWER LDMOS TRANSISTORS**



**TO-270-2**  
**PLASTIC**  
**AFT09MS031NR1**



**TO-270-2 GULL**  
**PLASTIC**  
**AFT09MS031GNR1**



(Top View)

Note: The backside of the package is the source terminal for the transistor.

**Figure 1. Pin Connections**

**Table 1. Maximum Ratings**

Rating	Symbol	Value	Unit
Drain-Source Voltage	$V_{DSS}$	-0.5, +40	Vdc
Gate-Source Voltage	$V_{GS}$	-6.0, +12	Vdc
Operating Voltage	$V_{DD}$	17, +0	Vdc
Storage Temperature Range	$T_{stg}$	-65 to +150	°C
Case Operating Temperature Range	$T_C$	-40 to +150	°C
Operating Junction Temperature Range (1,2)	$T_J$	-40 to +225	°C
Total Device Dissipation @ $T_C = 25^\circ\text{C}$ Derate above 25°C	$P_D$	317 1.59	W W/°C

**Table 2. Thermal Characteristics**

Characteristic	Symbol	Value (2,3)	Unit
Thermal Resistance, Junction to Case Case Temperature 81°C, 31 W CW, 13.6 Vdc, $I_{DQ} = 500$ mA, 870 MHz	$R_{\theta JC}$	0.63	°C/W

**Table 3. ESD Protection Characteristics**

Test Methodology	Class
Human Body Model (per JESD22-A114)	2, passes 2500 V
Machine Model (per EIA/JESD22-A115)	A, passes 100 V
Charge Device Model (per JESD22-C101)	IV, passes 1200 V

**Table 4. Moisture Sensitivity Level**

Test Methodology	Rating	Package Peak Temperature	Unit
Per JESD22-A113, IPC/JEDEC J-STD-020	3	260	°C

**Table 5. Electrical Characteristics** ( $T_A = 25^\circ\text{C}$  unless otherwise noted)

Characteristic	Symbol	Min	Typ	Max	Unit
<b>Off Characteristics</b>					
Zero Gate Voltage Drain Leakage Current ( $V_{DS} = 40$ Vdc, $V_{GS} = 0$ Vdc)	$I_{DSS}$	—	—	2	$\mu\text{Adc}$
Zero Gate Voltage Drain Leakage Current ( $V_{DS} = 13.6$ Vdc, $V_{GS} = 0$ Vdc)	$I_{DSS}$	—	—	1	$\mu\text{Adc}$
Gate-Source Leakage Current ( $V_{GS} = 5$ Vdc, $V_{DS} = 0$ Vdc)	$I_{GSS}$	—	—	600	nAdc
<b>On Characteristics</b>					
Gate Threshold Voltage ( $V_{DS} = 10$ Vdc, $I_D = 115$ $\mu\text{Adc}$ )	$V_{GS(th)}$	1.6	2.1	2.6	Vdc
Drain-Source On-Voltage ( $V_{GS} = 10$ Vdc, $I_D = 1.2$ Adc)	$V_{DS(on)}$	—	0.1	—	Vdc
Forward Transconductance ( $V_{GS} = 10$ Vdc, $I_D = 10$ Adc)	$g_{fs}$	—	7.8	—	S

1. Continuous use at maximum temperature will affect MTTF.
2. MTTF calculator available at <http://www.freescale.com/rf>. Select Software & Tools/Development Tools/Calculators to access MTTF calculators by product.
3. Refer to AN1955, *Thermal Measurement Methodology of RF Power Amplifiers*. Go to <http://www.freescale.com/rf>. Select Documentation/Application Notes - AN1955.

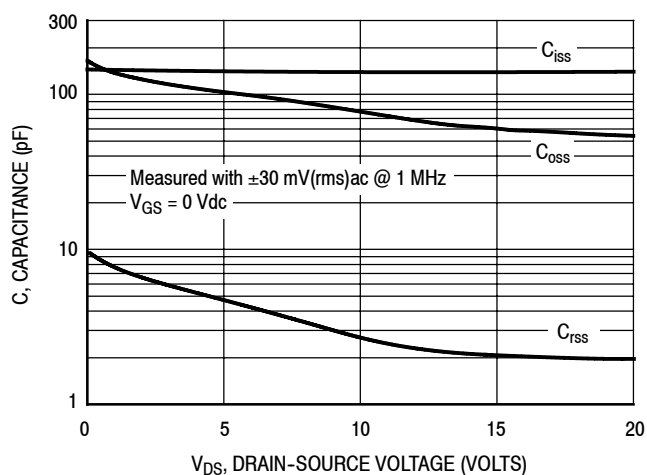
(continued)

**Table 5. Electrical Characteristics** ( $T_A = 25^\circ\text{C}$  unless otherwise noted) (continued)

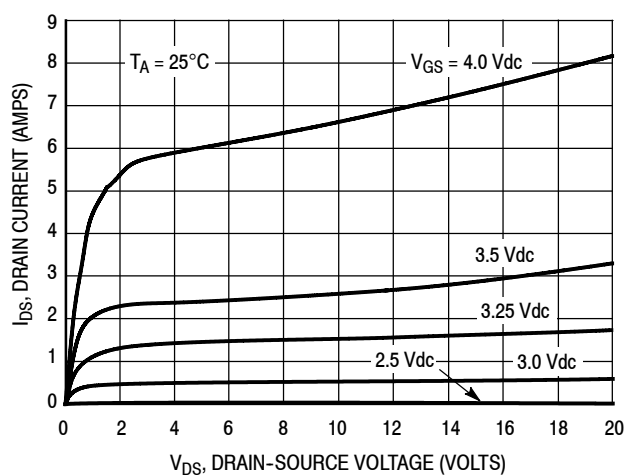
Characteristic	Symbol	Min	Typ	Max	Unit
<b>Dynamic Characteristics</b>					
Reverse Transfer Capacitance ( $V_{DS} = 13.6\text{ Vdc} \pm 30\text{ mV(rms)ac}$ @ 1 MHz, $V_{GS} = 0\text{ Vdc}$ )	$C_{rss}$	—	2.1	—	pF
Output Capacitance ( $V_{DS} = 13.6\text{ Vdc} \pm 30\text{ mV(rms)ac}$ @ 1 MHz, $V_{GS} = 0\text{ Vdc}$ )	$C_{oss}$	—	63	—	pF
Input Capacitance ( $V_{DS} = 13.6\text{ Vdc}$ , $V_{GS} = 0\text{ Vdc} \pm 30\text{ mV(rms)ac}$ @ 1 MHz)	$C_{iss}$	—	140	—	pF
<b>Functional Tests</b> <sup>(1)</sup> (In Freescale Narrowband Test Fixture, 50 ohm system) $V_{DD} = 13.6\text{ Vdc}$ , $I_{DQ} = 500\text{ mA}$ , $P_{out} = 31\text{ W}$ , $f = 870\text{ MHz}$					
Common-Source Amplifier Power Gain	$G_{ps}$	16.0	17.2	18.5	dB
Drain Efficiency	$\eta_D$	68.0	71.0	—	%
<b>Load Mismatch/Ruggedness</b> (In Freescale Test Fixture, 50 ohm system, $I_{DQ} = 500\text{ mA}$ )					
Frequency (MHz)	Signal Type	VSWR	$P_{in}$ (W)	Test Voltage, $V_{DD}$	Result
870	CW	>65:1 at all Phase Angles	1.2 (3 dB Overdrive)	17	No Device Degradation

1. Measurement made with device in straight lead configuration before any lead forming operation is applied. Lead forming is used for gull wing (GN) parts.

### TYPICAL CHARACTERISTICS

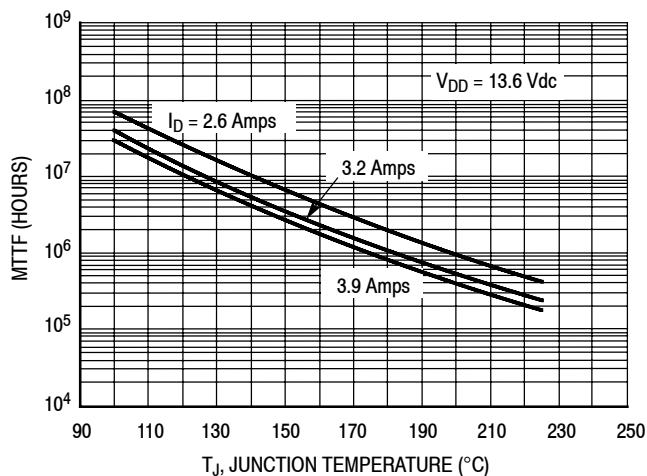


**Figure 2. Capacitance versus Drain-Source Voltage**



**Note:** Measured with both sides of the transistor tied together.

**Figure 3. Drain Current versus Drain-Source Voltage**

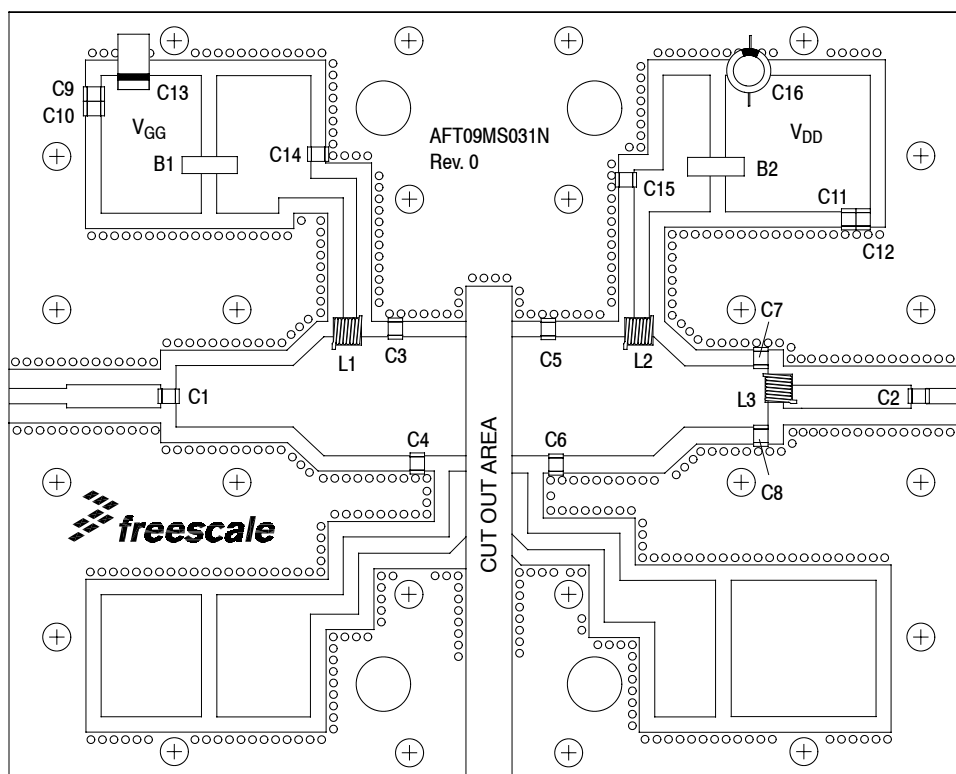


**Note:** MTTF value represents the total cumulative operating time under indicated test conditions.

MTTF calculator available at <http://www.freescale.com/rf>. Select Software & Tools/Development Tools/Calculators to access MTTF calculators by product.

**Figure 4. MTTF versus Junction Temperature - CW**

## 870 MHz NARROWBAND PRODUCTION TEST FIXTURE



**Figure 5. AFT09MS031NR1 Narrowband Test Circuit Component Layout — 870 MHz**

**Table 6. AFT09MS031NR1 Narrowband Test Circuit Component Designations and Values — 870 MHz**

Part	Description	Part Number	Manufacturer
B1, B2	RF Beads, Long	2743021447	Fair-Rite
C1	3.9 pF Chip Capacitor	ATC100B3R9CT500XT	ATC
C2, C14, C15	56 pF Chip Capacitors	ATC100B560CT500XT	ATC
C3, C4, C5, C6	10 pF Chip Capacitors	ATC100B100JT500XT	ATC
C7, C8	3.6 pF Chip Capacitors	ATC100B3R6CT500XT	ATC
C9	2.5 $\mu$ F Chip Capacitor	GRM31CR71H225KA88L	Murata
C10, C11	0.1 $\mu$ F Chip Capacitors	C1206C104K1RAC-TU	Kemet
C12	10,000 pF Chip Capacitor	ATC200B103KT50XT	ATC
C13	22 $\mu$ F, 25 V Tantalum Capacitor	TPSD226M025R0200	AVX
C16	330 $\mu$ F, 35 V Electrolytic Capacitor	MCGPR35V337M10X16-RH	Multicomp
L1	8.0 nH Inductor	A03TKLC	Coilcraft
L2	18.5 nH Inductor	A05TKLC	Coilcraft
L3	5.0 nH Inductor	A02TKLC	Coilcraft
PCB	0.030", $\epsilon_r = 3.5$	RO4350B	Rogers

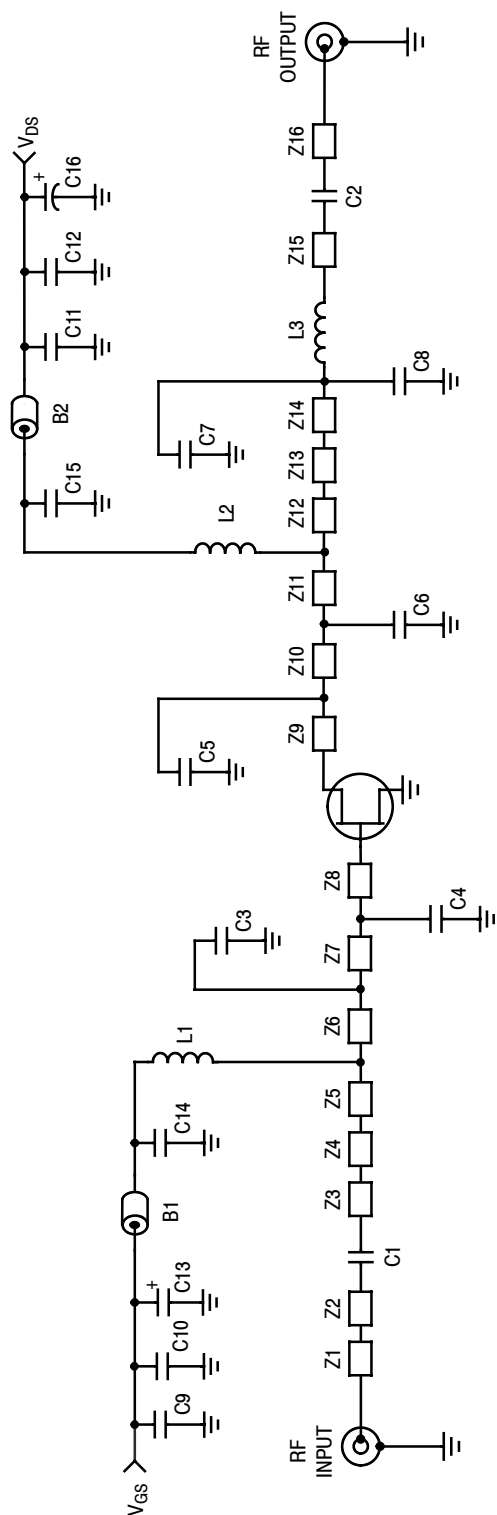
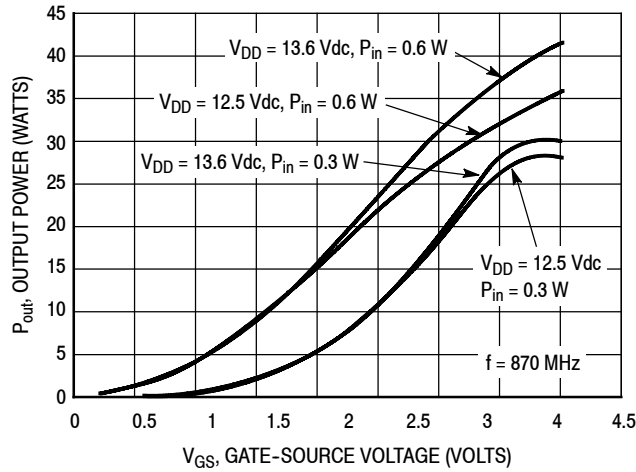


Figure 6. AFT09MS031NR1 Narrowband Test Circuit Schematic — 870 MHz

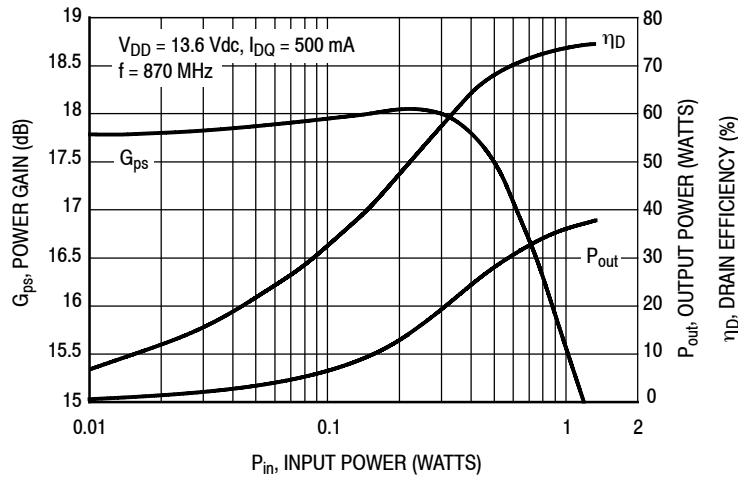
Table 7. AFT09MS031NR1 Narrowband Test Circuit Microstrips — 870 MHz

Microstrip	Description
Z1	0.280" x 0.080" Microstrip
Z2	0.490" x 0.120" Microstrip
Z3	0.610" x 0.320" Microstrip
Z4	0.320" x 0.155" x 0.620" Microstrip Taper
Z5	0.139" x 0.620" Microstrip
Z6	0.225" x 0.620" Microstrip
Z7	0.121" x 0.620" Microstrip
Z8	0.254" x 0.620" Microstrip
Z9	0.190" x 0.080" Microstrip
Z10	0.040" x 0.080" Microstrip
Z11	0.454" x 0.520" Microstrip
Z12	0.054" x 0.520" Microstrip
Z13	0.620" x 0.420" x 0.620" Microstrip Taper
Z14	0.433" x 0.420" Microstrip
Z15	0.665" x 0.420" Microstrip
Z16	0.200" x 0.420" Microstrip

### TYPICAL CHARACTERISTICS — 870 MHz



**Figure 7. CW Output Power versus Gate-Source Voltage**



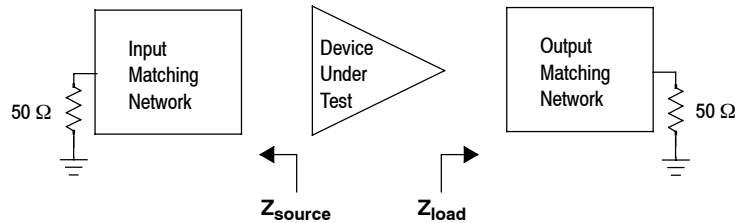
**Figure 8. Power Gain, CW Output Power and Drain Efficiency versus Input Power**

$V_{DD} = 13.6 \text{ Vdc}$ ,  $I_{DQ} = 500 \text{ mA}$ ,  $P_{out} = 31 \text{ W Avg.}$

f MHz	$Z_{source}$ Ω	$Z_{load}$ Ω
870	$0.28 - j0.71$	$0.98 - j0.52$

$Z_{source}$  = Test circuit impedance as measured from gate to ground.

$Z_{load}$  = Test circuit impedance as measured from drain to ground.



**Figure 9. Narrowband Series Equivalent Source and Load Impedance — 870 MHz**

## 760-870 MHz BROADBAND REFERENCE CIRCUIT

**Table 8. 760-870 MHz Broadband Performance** (In Freescale Reference Circuit, 50 ohm system)  
 $V_{DD} = 13.6$  Volts,  $I_{DQ} = 100$  mA,  $T_A = 25^\circ\text{C}$ , CW

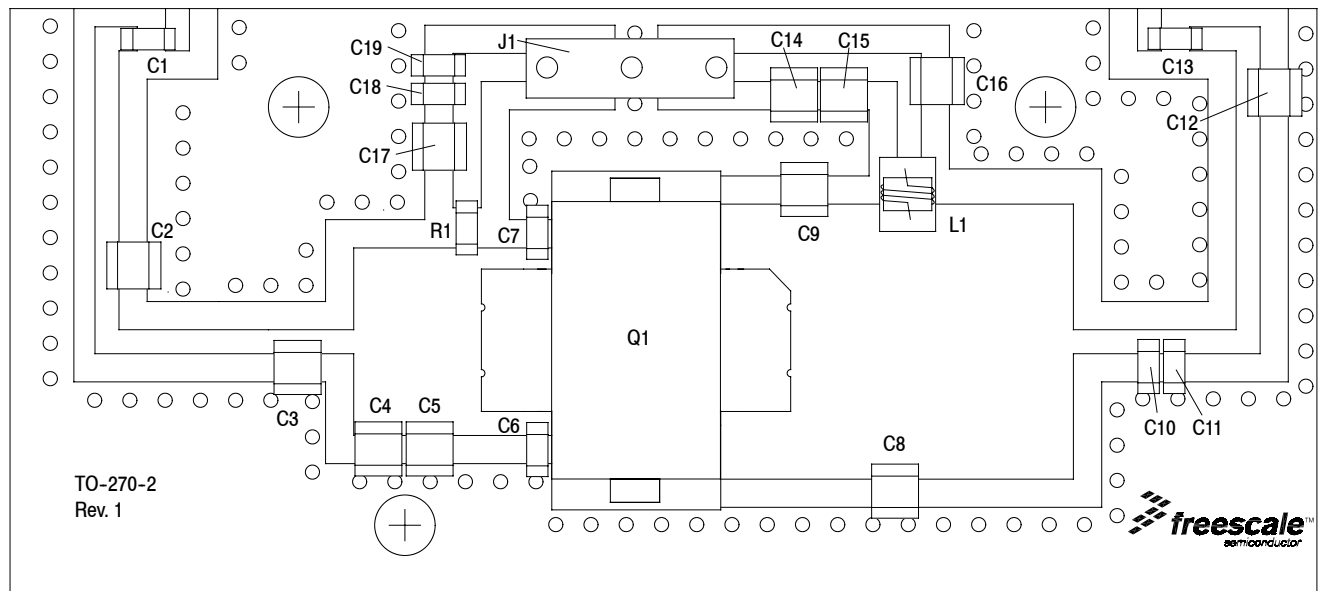
Frequency (MHz)	$G_{ps}$ (dB)	$\eta_D$ (%)	P1dB (W)
760	15.7	62.0	44
820	15.7	63.0	37
870	15.5	61.0	36

**Table 9. Load Mismatch/Ruggedness** (In Freescale Reference Circuit)

Frequency (MHz)	Signal Type	VSWR	$P_{in}$ (W)	Test Voltage, $V_{DD}$	Result
870	CW	>65:1 at all Phase Angles	2.0 (3 dB Overdrive)	17	No Device Degradation



## 760-870 MHz BROADBAND REFERENCE CIRCUIT



**Figure 10. AFT09MS031NR1 Broadband Reference Circuit Component Layout — 760-870 MHz**

**Table 10. AFT09MS031NR1 Broadband Reference Circuit Component Designations and Values — 760-870 MHz**

Part	Description	Part Number	Manufacturer
C1, C10, C11, C12	5.6 pF Chip Capacitors	ATC600F5R6BT250XT	ATC
C2	6.8 pF Chip Capacitor	ATC600F6R8BT250XT	ATC
C3	8.2 pF Chip Capacitor	ATC600F8R2BT250XT	ATC
C4	12 pF Chip Capacitor	ATC600F120JT250XT	ATC
C5	10 pF Chip Capacitor	ATC600F100JT250XT	ATC
C6, C7	30 pF Chip Capacitors	ATC600F300JT250XT	ATC
C8, C9	22 pF Chip Capacitors	ATC600F220JT250XT	ATC
C13, C16, C17	240 pF Chip Capacitors	ATC600F241JT250XT	ATC
C14, C19	10 $\mu$ F Chip Capacitors	GRM31CR61H106KA12L	Murata
C15, C18	1 $\mu$ F Chip Capacitors	GRM21BR71H105KA12L	Murata
J1	3 Pin Connector	AMP-9-146305-0	TE Connectivity
L1	6.9 nH Inductor	0807SQ6N9	Coilcraft
Q1	RF Power LDMOS Transistor	AFT09MS031NR1	Freescale
R1	62 $\Omega$ Chip Resistor	RG2012N-620-B-T1	Susumu
PCB	0.020", $\epsilon_r = 4.8$	S1000-2	Shengyi

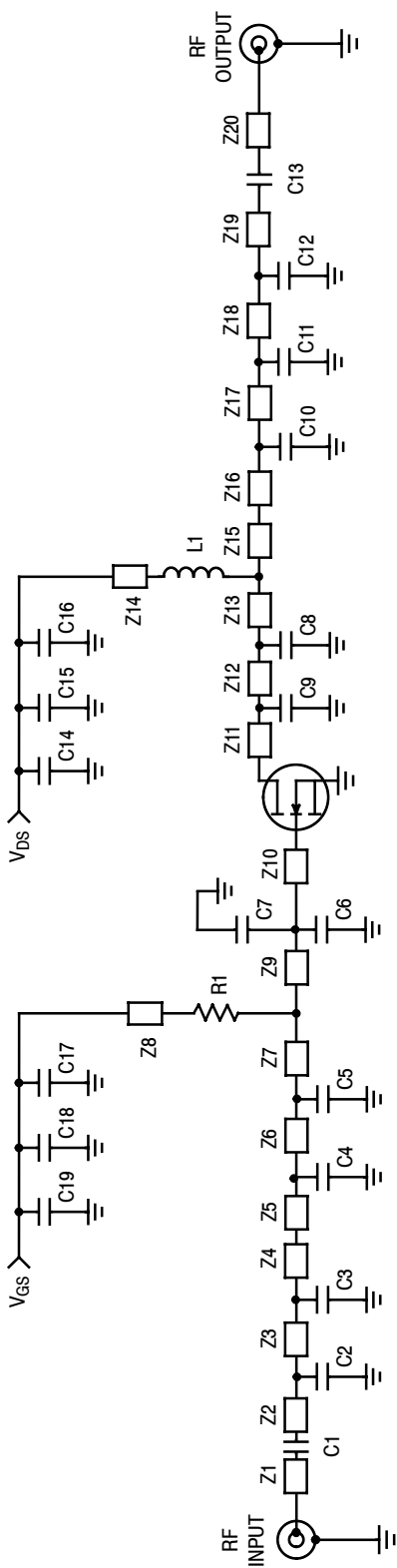


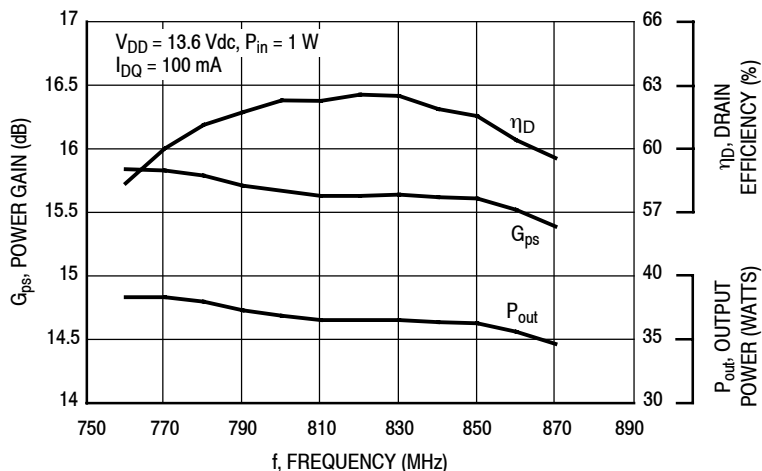
Figure 11. AFT09MS031NR1 Broadband Reference Circuit Schematic — 760-870 MHz

Table 11. AFT09MS031NR1 Broadband Reference Circuit Microstrips — 760-870 MHz

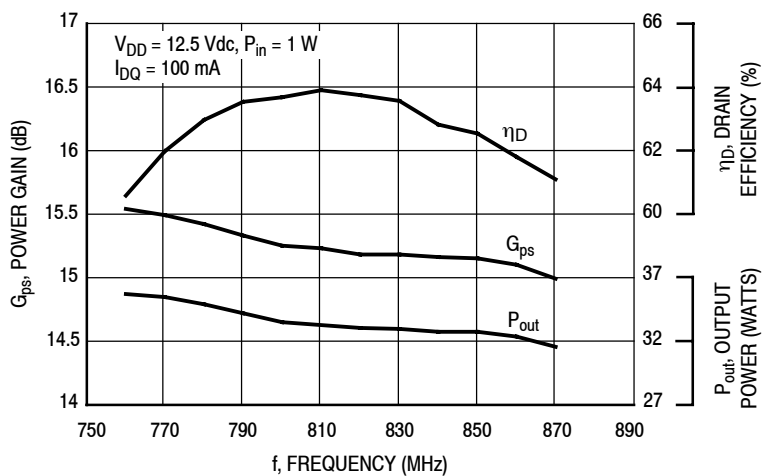
Microstrip	Description	Microstrip	Description
Z1, Z20	0.034" x 0.060" Microstrip	Z11, Z12	0.390" x 0.120" Microstrip
Z2*	0.034" x 0.380" Microstrip	Z13	0.390" x 0.080" Microstrip
Z3*	0.034" x 0.215" Microstrip	Z14	0.034" x 0.100" Microstrip
Z4	0.034" x 0.054" Microstrip	Z15	0.390" x 0.200" Microstrip
Z5, Z6	0.266" x 0.025" Microstrip	Z16	0.034" x 0.110" Microstrip
Z7, Z9	0.266" x 0.080" Microstrip	Z17	0.034" x 0.010" Microstrip
Z8	0.034" x 0.050" Microstrip	Z18*	0.034" x 0.190" Microstrip
Z10	0.266" x 0.015" Microstrip	Z19*	0.034" x 0.110" Microstrip

\* Line length includes microstrip bends

## TYPICAL CHARACTERISTICS — 760-860 MHz BROADBAND REFERENCE CIRCUIT

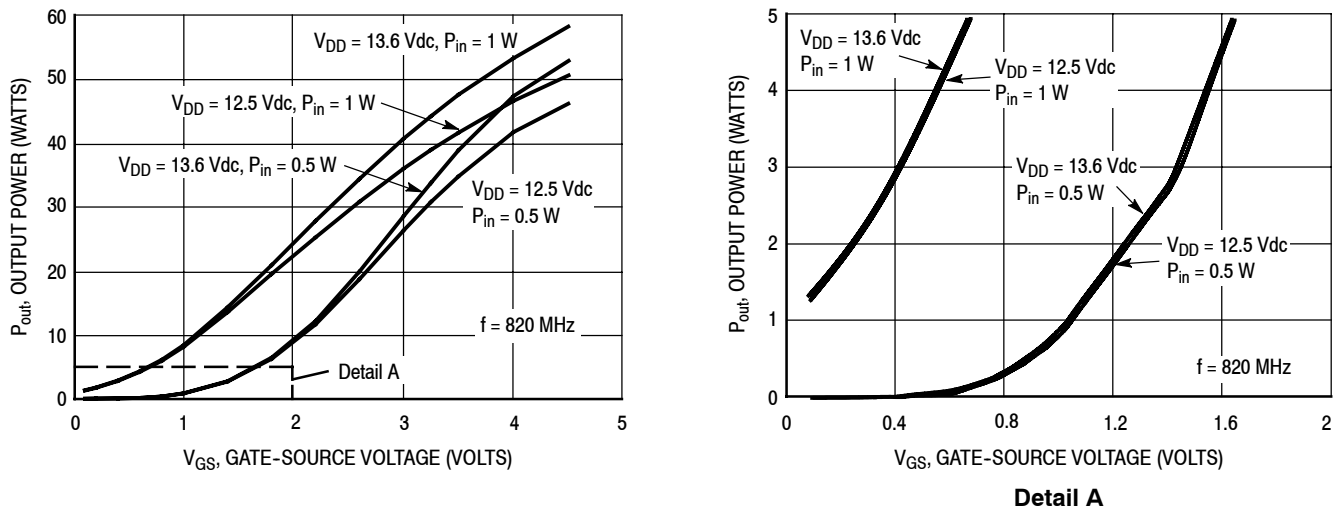


**Figure 12. Power Gain, CW Output Power and Drain Efficiency versus Frequency at a Constant Input Power**

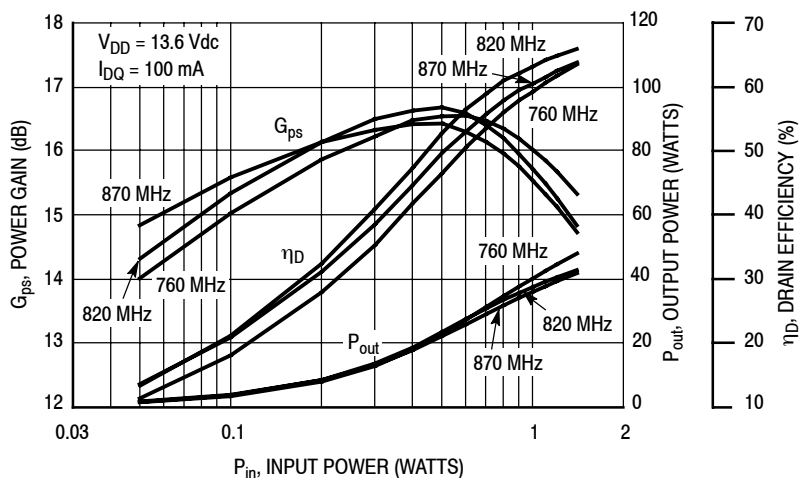


**Figure 13. Power Gain, CW Output Power and Drain Efficiency versus Frequency at a Constant Input Power**

### TYPICAL CHARACTERISTICS — 760-870 MHz BROADBAND REFERENCE CIRCUIT

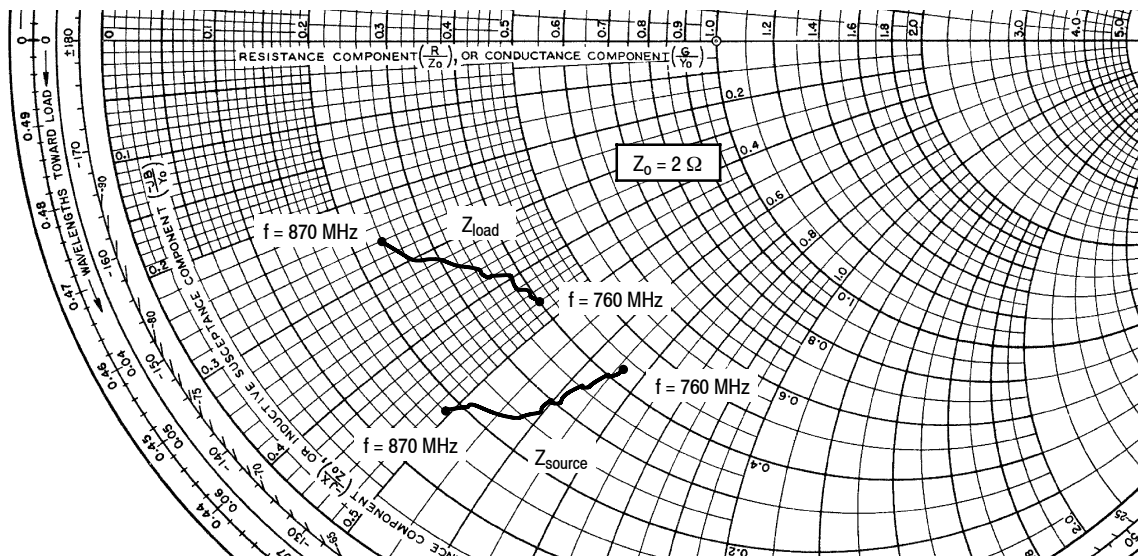


**Figure 14. CW Output Power versus Gate-Source Voltage**



**Figure 15. Power Gain, CW Output Power and Drain Efficiency versus Input Power and Frequency**

### 760-870 MHz BROADBAND REFERENCE CIRCUIT



$V_{DD} = 13.6 \text{ Vdc}$ ,  $I_{DQ} = 100 \text{ mA}$ ,  $P_{out} = 31 \text{ W Avg.}$

f MHz	$Z_{source}$ $\Omega$	$Z_{load}$ $\Omega$
760	$0.85 - j1.31$	$0.80 - j0.92$
770	$0.80 - j1.30$	$0.78 - j0.88$
780	$0.75 - j1.28$	$0.78 - j0.85$
790	$0.69 - j1.26$	$0.76 - j0.81$
800	$0.65 - j1.24$	$0.76 - j0.78$
810	$0.59 - j1.21$	$0.72 - j0.75$
820	$0.55 - j1.18$	$0.70 - j0.73$
830	$0.51 - j1.15$	$0.67 - j0.70$
840	$0.46 - j1.11$	$0.62 - j0.66$
850	$0.42 - j1.01$	$0.57 - j0.62$
860	$0.39 - j1.02$	$0.52 - j0.57$
870	$0.36 - j0.97$	$0.48 - j0.52$

$Z_{source}$  = Test circuit impedance as measured from gate to ground.

$Z_{load}$  = Test circuit impedance as measured from drain to ground.

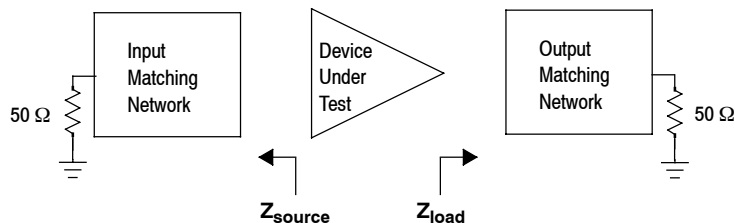
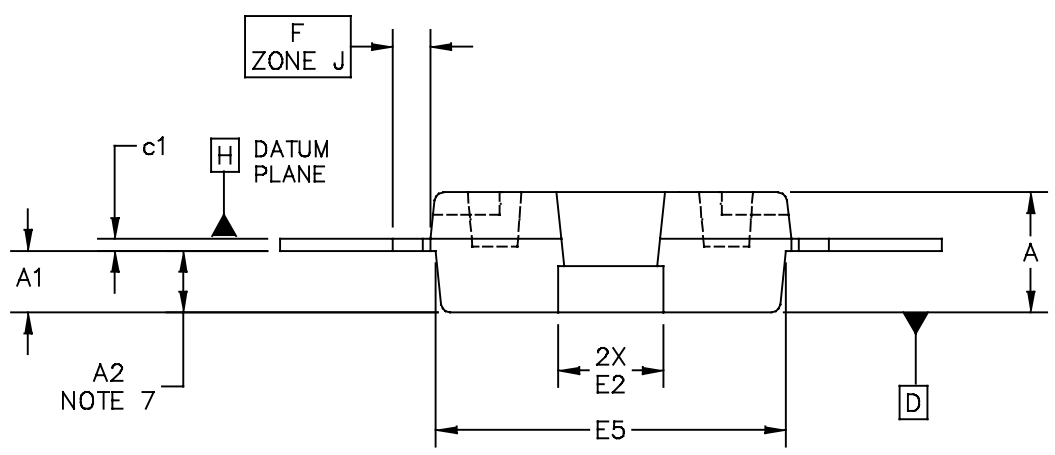
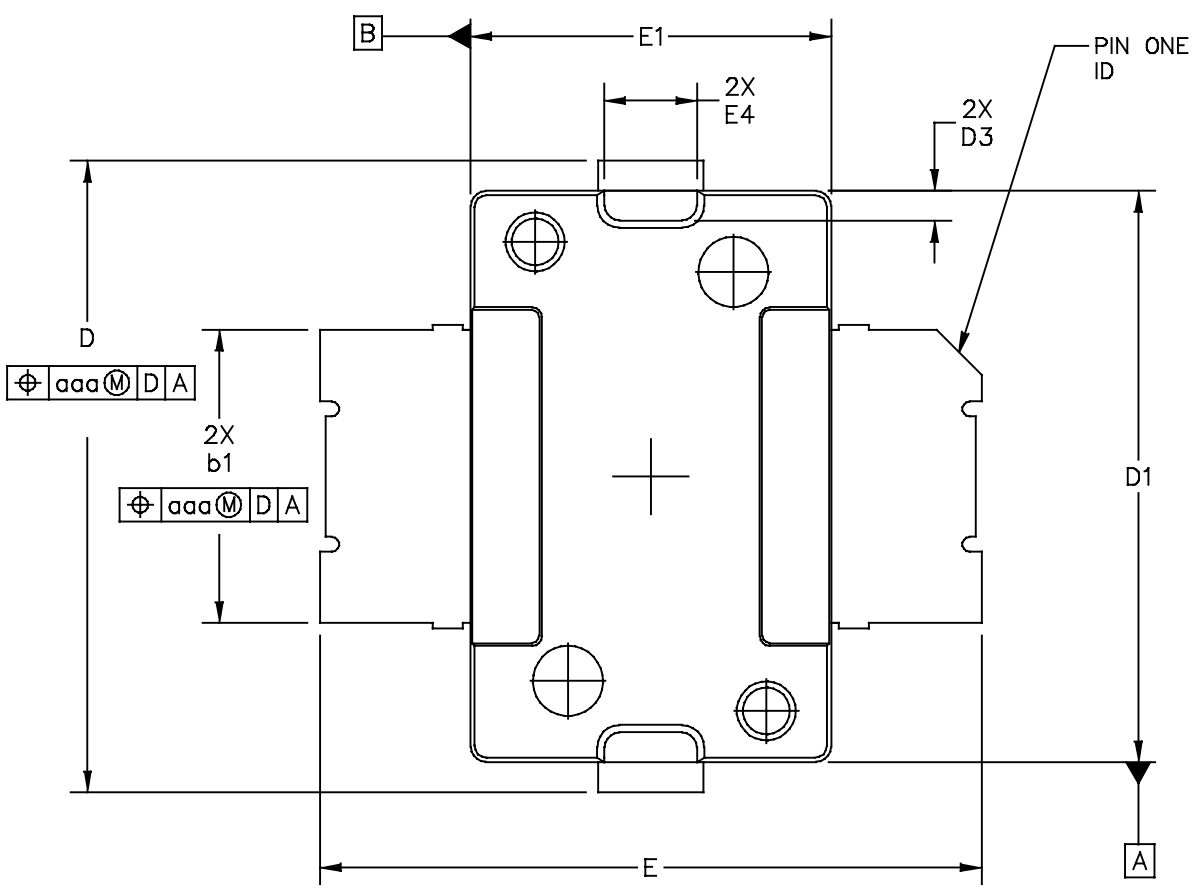
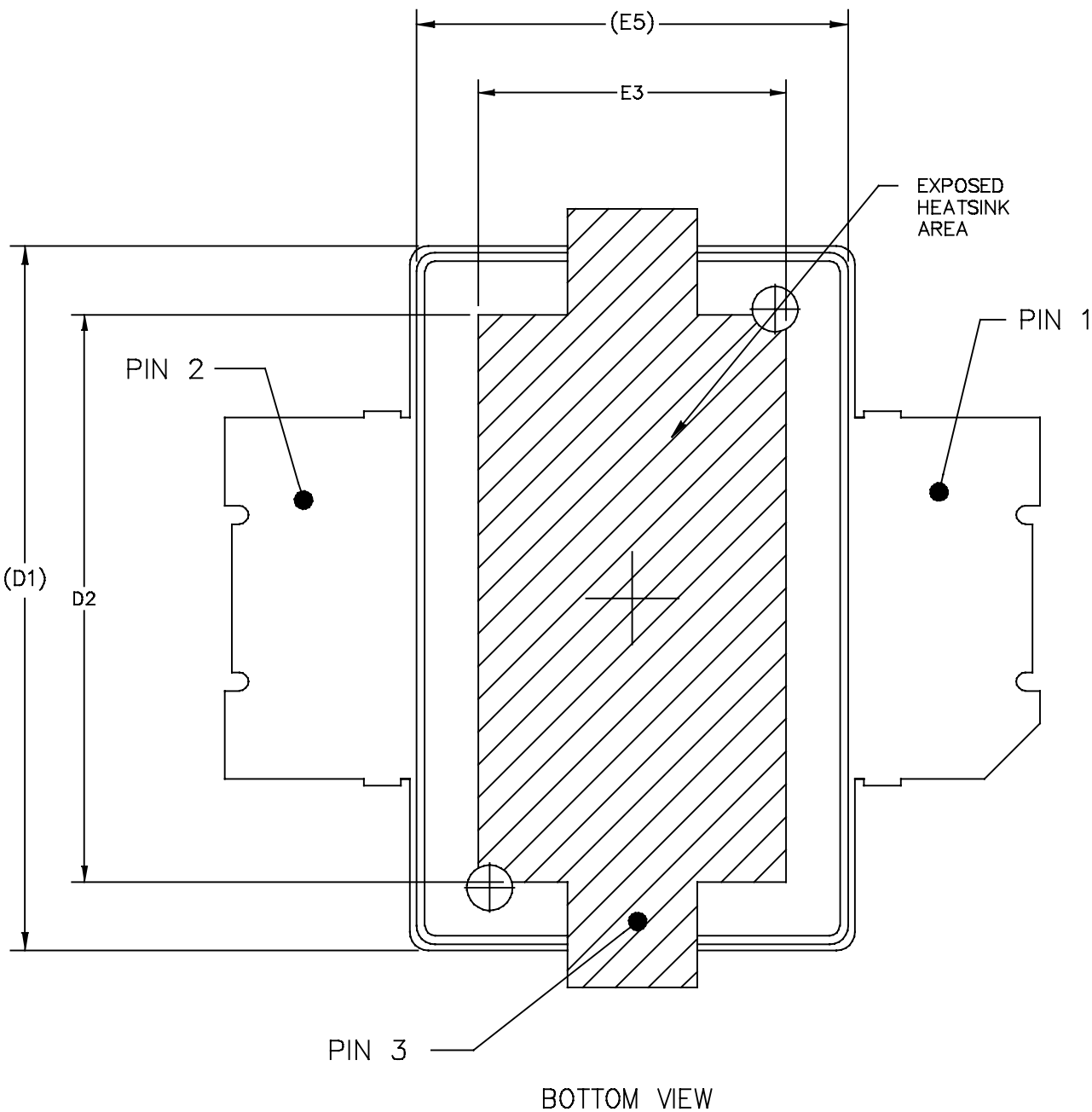


Figure 14. Broadband Series Equivalent Source and Load Impedance — 760-870 MHz

**PACKAGE DIMENSIONS**



© FREESCALE SEMICONDUCTOR, INC. ALL RIGHTS RESERVED.	MECHANICAL OUTLINE	PRINT VERSION NOT TO SCALE	
TITLE: <b>TO-270 SURFACE MOUNT</b>	DOCUMENT NO: 98ASH98117A	REV: K	
	CASE NUMBER: 1265-09	29 JUN 2007	
	STANDARD: JEDEC TO-270 AA		



© FREESCALE SEMICONDUCTOR, INC. ALL RIGHTS RESERVED.	MECHANICAL OUTLINE	PRINT VERSION NOT TO SCALE	
TITLE: <div style="text-align: center; padding: 5px;">           TO-270            SURFACE MOUNT         </div>	DOCUMENT NO: 98ASH98117A	REV: K	
	CASE NUMBER: 1265-09	29 JUN 2007	
	STANDARD: JEDEC TO-270 AA		

NOTES:

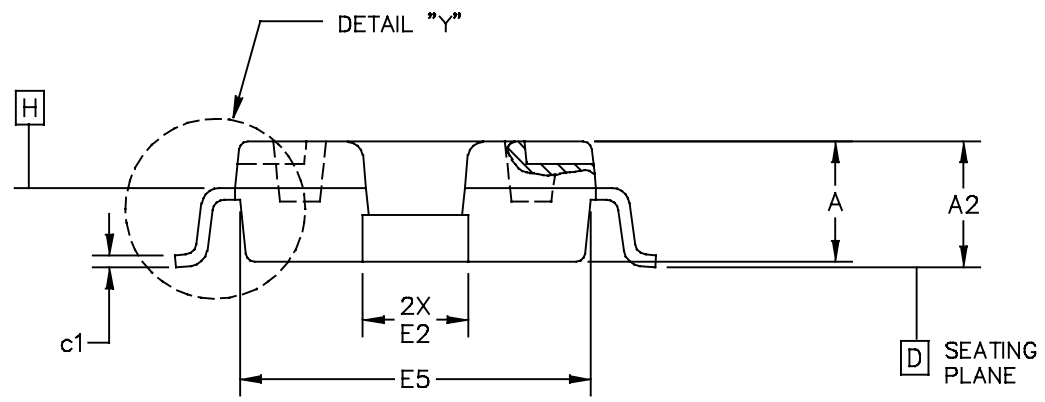
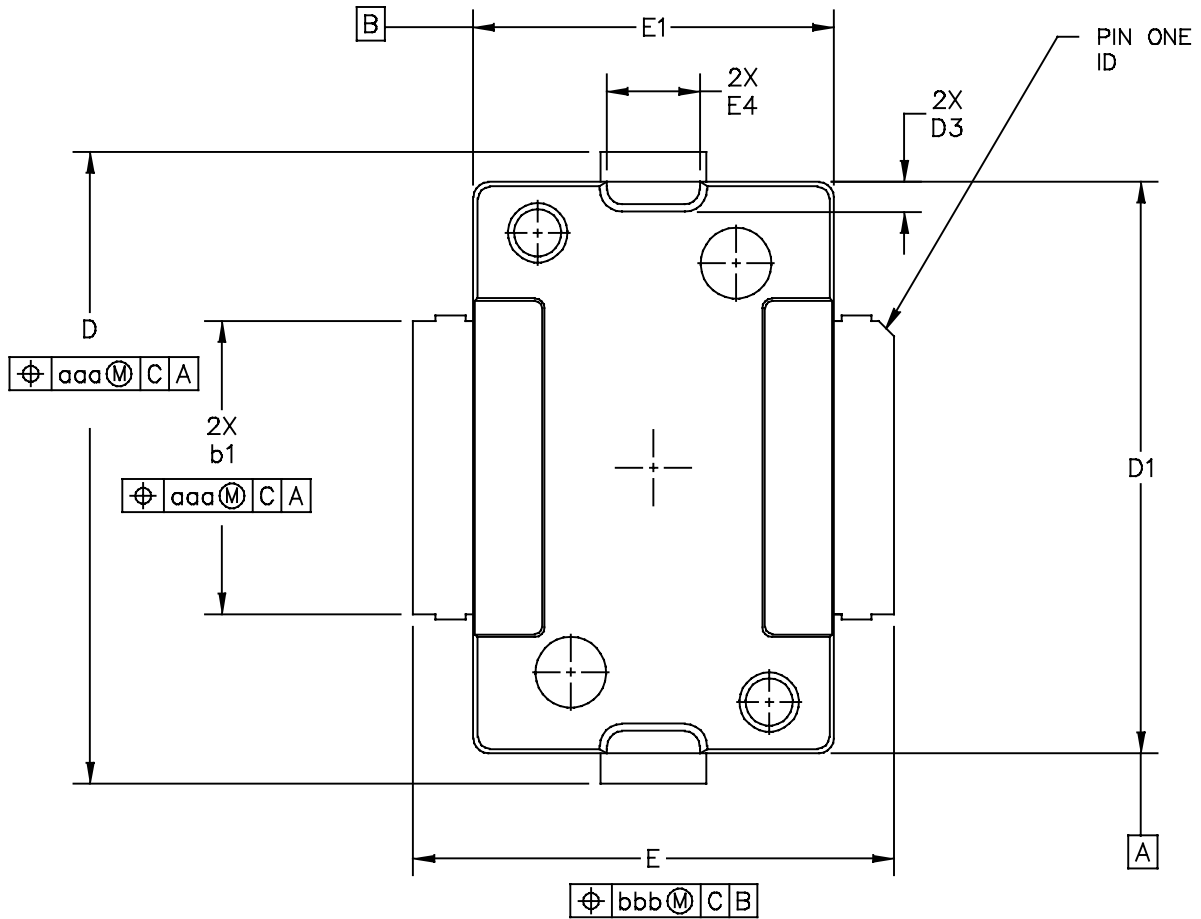
1. CONTROLLING DIMENSION: INCH
2. INTERPRET DIMENSIONS AND TOLERANCES PER ASME Y14.5M-1994.
3. DATUM PLANE -H- IS LOCATED AT TOP OF LEAD AND IS COINCIDENT WITH THE LEAD WHERE THE LEAD EXITS THE PLASTIC BODY AT THE TOP OF THE PARTING LINE.
4. DIMENSIONS "D1" AND "E1" DO NOT INCLUDE MOLD PROTRUSION. ALLOWABLE PROTRUSION IS .006 PER SIDE. DIMENSIONS "D1" AND "E1" DO INCLUDE MOLD MISMATCH AND ARE DETERMINED AT DATUM PLANE -H-.
5. DIMENSION "b1" DOES NOT INCLUDE DAMBAR PROTRUSION. ALLOWABLE DAMBAR PROTRUSION SHALL BE .005 TOTAL IN EXCESS OF THE "b1" DIMENSION AT MAXIMUM MATERIAL CONDITION.
6. DATUMS -A- AND -B- TO BE DETERMINED AT DATUM PLANE -H-.
7. DIMENSION "A2" APPLIES WITHIN ZONE "J" ONLY.
8. DIMENSIONS "D" AND "E2" DO NOT INCLUDE MOLD PROTRUSION. OVERALL LENGTH INCLUDING MOLD PROTRUSION SHOULD NOT EXCEED 0.430 INCH FOR DIMENSION "D" AND 0.080 INCH FOR DIMENSION "E2". DIMENSIONS "D" AND "E2" DO INCLUDE MOLD MISMATCH AND ARE DETERMINED AT DATUM PLANE -D-.

STYLE 1:  
 PIN 1 - DRAIN  
 PIN 2 - GATE  
 PIN 3 - SOURCE

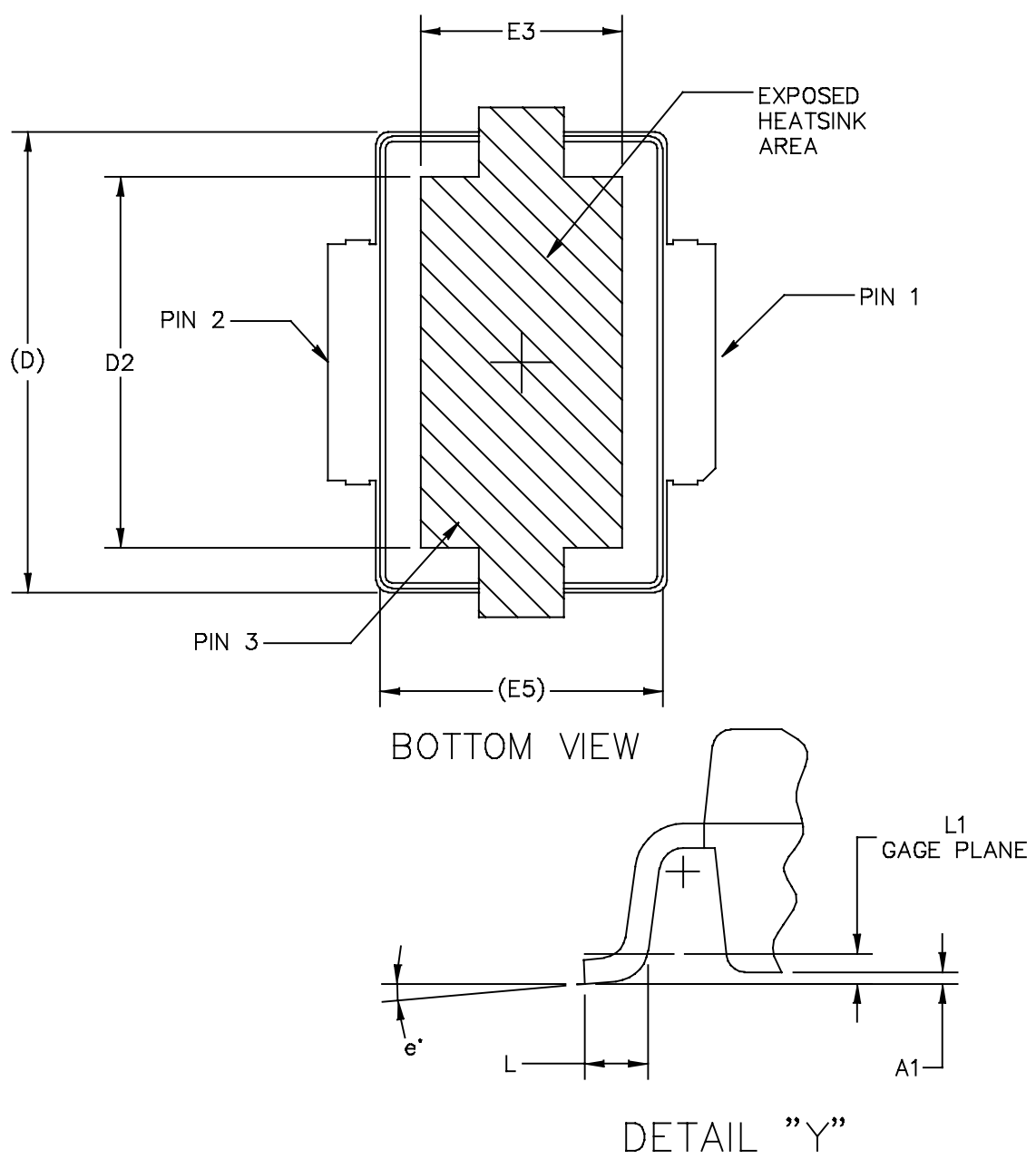
DIM	INCH		MILLIMETER		DIM	INCH		MILLIMETER	
	MIN	MAX	MIN	MAX		MIN	MAX	MIN	MAX
A	.078	.082	1.98	2.08	F	.025 BSC		0.64 BSC	
A1	.039	.043	0.99	1.09	b1	.193	.199	4.90	5.06
A2	.040	.042	1.02	1.07	c1	.007	.011	0.18	0.28
D	.416	.424	10.57	10.77	aaa	.004		0.10	
D1	.378	.382	9.60	9.70					
D2	.290	----	7.37	----					
D3	.016	.024	0.41	0.61					
E	.436	.444	11.07	11.28					
E1	.238	.242	6.04	6.15					
E2	.066	.074	1.68	1.88					
E3	.150	----	3.81	----					
E4	.058	.066	1.47	1.68					
E5	.231	.235	5.87	5.97					

© FREESCALE SEMICONDUCTOR, INC. ALL RIGHTS RESERVED.		MECHANICAL OUTLINE		PRINT VERSION NOT TO SCALE	
TITLE:  TO-270 SURFACE MOUNT			DOCUMENT NO: 98ASH98117A		REV: K
			CASE NUMBER: 1265-09		29 JUN 2007
			STANDARD: JEDEC TO-270 AA		





© FREESCALE SEMICONDUCTOR, INC. ALL RIGHTS RESERVED.		MECHANICAL OUTLINE	PRINT VERSION NOT TO SCALE
TITLE: TO-270 GULL WING		DOCUMENT NO: 98ASA99301D	REV: C
		CASE NUMBER: 1265A-03	02 JUL 2007
		STANDARD: JEDEC TO-270 BA	



© FREESCALE SEMICONDUCTOR, INC. ALL RIGHTS RESERVED.	MECHANICAL OUTLINE	PRINT VERSION NOT TO SCALE	
TITLE:  TO-270 GULL WING	DOCUMENT NO: 98ASA99301D	REV: C	
	CASE NUMBER: 1265A-03	02 JUL 2007	
	STANDARD: JEDEC TO-270 BA		

NOTES:

1. CONTROLLING DIMENSION: INCH
2. INTERPRET DIMENSIONS AND TOLERANCES PER ASME Y14.5M-1994.
3. DATUM PLANE -H- IS LOCATED AT TOP OF LEAD AND IS COINCIDENT WITH THE LEAD WHERE THE LEAD EXITS THE PLASTIC BODY AT THE TOP OF THE PARTING LINE.
4. DIMENSIONS "D1" AND "E1" DO NOT INCLUDE MOLD PROTRUSION. ALLOWABLE PROTRUSION IS .006 PER SIDE. DIMENSIONS "D1 AND "E1" DO INCLUDE MOLD MISMATCH AND ARE DETERMINED AT DATUM PLANE -H-.
5. DIMENSION b1 DOES NOT INCLUDE DAMBAR PROTRUSION. ALLOWABLE DAMBAR PROTRUSION SHALL BE .005 TOTAL IN EXCESS OF THE b1 DIMENSION AT MAXIMUM MATERIAL CONDITION.
6. DATUMS -A- AND -B- TO BE DETERMINED AT DATUM PLANE -H-.
7. DIMENSIONS "D" AND "E2" DO NOT INCLUDE MOLD PROTRUSION. ALLOWABLE PROTRUSION IS .003 PER SIDE. DIMENSIONS "D AND "E2" DO INCLUDE MOLD MISMATCH AND ARE DETERMINED AT DATUM PLANE -D-.

STYLE 1:

- PIN 1 - DRAIN
- PIN 2 - GATE
- PIN 3 - SOURCE

DIM	INCH		MILLIMETER		DIM	INCH		MILLIMETER	
	MIN	MAX	MIN	MAX		MIN	MAX	MIN	MAX
A	.078	.082	1.98	2.08	L	.018	.024	0.46	0.61
A1	.001	.004	0.02	0.10	L1	.01 BSC		0.25 BSC	
A2	.077	.088	1.96	2.24	b1	.193	.199	4.90	5.06
D	.416	.424	10.57	10.77	c1	.007	.011	0.18	0.28
D1	.378	.382	9.60	9.70	e	2'	8'	2'	8'
D2	.290	-	7.37	-	aaa	.004		0.10	
D3	.016	.024	0.41	0.61					
E	.316	.324	8.03	8.23					
E1	.238	.242	6.04	6.15					
E2	.066	.074	1.68	1.88					
E3	.150	-	3.81	-					
E4	.058	.066	1.47	1.68					
E5	.231	.235	5.87	5.97					
© FREESCALE SEMICONDUCTOR, INC. ALL RIGHTS RESERVED.			MECHANICAL OUTLINE			PRINT VERSION NOT TO SCALE			
TITLE:  TO-270 GULL WING					DOCUMENT NO: 98ASA99301D			REV: C	
					CASE NUMBER: 1265A-03			02 JUL 2007	
					STANDARD: JEDEC TO-270 BA				

## PRODUCT DOCUMENTATION, SOFTWARE AND TOOLS

Refer to the following documents, software and tools to aid your design process.

### Application Notes

- AN1907: Solder Reflow Attach Method for High Power RF Devices in Over-Molded Plastic Packages
- AN1955: Thermal Measurement Methodology of RF Power Amplifiers
- AN3263: Bolt Down Mounting Method for High Power RF Transistors and RFICs in Over-Molded Plastic Packages
- AN3789: Clamping of High Power RF Transistors and RFICs in Over-Molded Plastic Packages

### Engineering Bulletins

- EB212: Using Data Sheet Impedances for RF LDMOS Devices

### Software

- Electromigration MTTF Calculator
- RF High Power Model
- .s2p File

### Development Tools

- Printed Circuit Boards

For Software and Tools, do a Part Number search at <http://www.freescale.com>, and select the “Part Number” link. Go to the Software & Tools tab on the part’s Product Summary page to download the respective tool.

## REVISION HISTORY

The following table summarizes revisions to this document.

Revision	Date	Description
0	May 2012	<ul style="list-style-type: none"> <li>• Initial Release of Data Sheet</li> </ul>
1	Aug. 2012	<ul style="list-style-type: none"> <li>• Load Mismatch/Ruggedness tables: changed output power to input power to clarify the conditions used during test, p. 1, 8</li> <li>• Fig. 10, Broadband Reference Circuit Component Layout — 760-870 MHz: added C18 and C19; replaced L1 with R1 and L2 with L1, p. 9</li> <li>• Table 10, Broadband Reference Circuit Component Designations and Values — 760-870 MHz: changed C14 description from 0.10 <math>\mu</math>F to 10 <math>\mu</math>F and part number from GRM21BR71H104KA01B to GRM31CR61H106KA12L; changed C15 description from 0.01 <math>\mu</math>F to 1 <math>\mu</math>F and part number from GRM21BR72A103KA01B to GRM21BR71H105KA12L; changed C17 description from 22 pF to 240 pF and part number from ATC100A220JT150XT to ATC600F241JT250XT; added C18 and C19; replaced L1 with R1 and L2 with L1, p. 9</li> <li>• Fig. 11, Broadband Reference Circuit Schematic — 760-870 MHz: added C18 and C19; replaced L1 with R1 and L2 with L1, p. 10</li> </ul> <p>Modifications to Fig. 10, Table 10 and Fig. 11 will improve stability of the test circuit and improve performance under a modulated signal, p. 9, 10</p>

### ***How to Reach Us:***

**Home Page:**  
[freescale.com](http://freescale.com)

**Web Support:**  
[freescale.com/support](http://freescale.com/support)

Information in this document is provided solely to enable system and software implementers to use Freescale products. There are no express or implied copyright licenses granted hereunder to design or fabricate any integrated circuits based on the information in this document.

Freescale reserves the right to make changes without further notice to any products herein. Freescale makes no warranty, representation, or guarantee regarding the suitability of its products for any particular purpose, nor does Freescale assume any liability arising out of the application or use of any product or circuit, and specifically disclaims any and all liability, including without limitation consequential or incidental damages. "Typical" parameters that may be provided in Freescale data sheets and/or specifications can and do vary in different applications, and actual performance may vary over time. All operating parameters, including "typicals," must be validated for each customer application by customer's technical experts. Freescale does not convey any license under its patent rights nor the rights of others. Freescale sells products pursuant to standard terms and conditions of sale, which can be found at the following address: [freescale.com/SalesTermsandConditions](http://freescale.com/SalesTermsandConditions).

Freescale, the Freescale logo, AltiVec, C-5, CodeTest, CodeWarrior, ColdFire, C-Ware, Energy Efficient Solutions logo, Kinetis, mobileGT, PowerQUICC, Processor Expert, QorIQ, Qorivva, StarCore, Symphony, and VortiQa are trademarks of Freescale Semiconductor, Inc., Reg. U.S. Pat. & Tm. Off. Airfast, BeeKit, BeeStack, ColdFire+, CoreNet, Flexis, MagniV, MXC, Platform in a Package, QorIQ Converge, QUICC Engine, Ready Play, SafeAssure, SMARTMOS, TurboLink, Vybrid, and Xtrinsic are trademarks of Freescale Semiconductor, Inc. All other product or service names are the property of their respective owners.

© 2012 Freescale Semiconductor, Inc.



## Стандарт Электрон Связь

Мы молодая и активно развивающаяся компания в области поставок электронных компонентов. Мы поставляем электронные компоненты отечественного и импортного производства напрямую от производителей и с крупнейших складов мира.

Благодаря сотрудничеству с мировыми поставщиками мы осуществляем комплексные и плановые поставки широчайшего спектра электронных компонентов.

Собственная эффективная логистика и склад в обеспечивает надежную поставку продукции в точно указанные сроки по всей России.

Мы осуществляем техническую поддержку нашим клиентам и предпродажную проверку качества продукции. На все поставляемые продукты мы предоставляем гарантию .

Осуществляем поставки продукции под контролем ВП МО РФ на предприятия военно-промышленного комплекса России , а также работаем в рамках 275 ФЗ с открытием отдельных счетов в уполномоченном банке. Система менеджмента качества компании соответствует требованиям ГОСТ ISO 9001.

Минимальные сроки поставки, гибкие цены, неограниченный ассортимент и индивидуальный подход к клиентам являются основой для выстраивания долгосрочного и эффективного сотрудничества с предприятиями радиоэлектронной промышленности, предприятиями ВПК и научно-исследовательскими институтами России.

С нами вы становитесь еще успешнее!

### Наши контакты:

**Телефон:** +7 812 627 14 35

**Электронная почта:** [sales@st-electron.ru](mailto:sales@st-electron.ru)

**Адрес:** 198099, Санкт-Петербург,  
Промышленная ул, дом № 19, литера Н,  
помещение 100-Н Офис 331