

DATA SHEET

SKY13550-667LF: 0.4 to 3.8 GHz DP8T (SP4T/SP4T) Main/Receive Diversity Switch with MIPI RFFE Interface for Carrier Aggregation

Applications

- 3G/4G multimode cellular handsets (UMTS and CDMA2000)
- Carrier aggregation diversity

Features

- Broadband frequency range: 0.4 to 3.8 GHz
- Single, positive DC power supply (2.5 to 4.8 V)
- Excellent Band 13 2nd harmonic performance
- Excellent Band 17 3rd harmonic performance
- Integrated, programmable MIPI interface using separate registers for ANT_A and ANT_B bands
- Dual antenna ports can be connected externally to a diplexer
- Small QFN (14-pin, 1.6 x 2.0 x 0.55 mm) package (MSL1, 260 °C per JEDEC J-STD-020)



Skyworks Green™ products are compliant with all applicable legislation and are halogen-free. For additional information, refer to *Skyworks Definition of Green™*, document number SQ04-0074.

Description

The SKY13550-667LF is a dual single-pole, four-throw (2xSP4T) Mobile Industry Processor Interface (MIPI) controlled antenna switch designed specifically for receive diversity in carrier aggregation applications.

The 2xSP4T switch is optimized for broadband performance. Using advanced switching technologies, the SKY13550-667LF maintains low insertion loss and high isolation for all switching paths. The high linearity performance and low insertion loss achieved by the SKY13550-667LF makes it an ideal choice for carrier aggregation applications. The switch also exhibits excellent second/third order intermodulation distortion (IMD2/IMD3) performance.

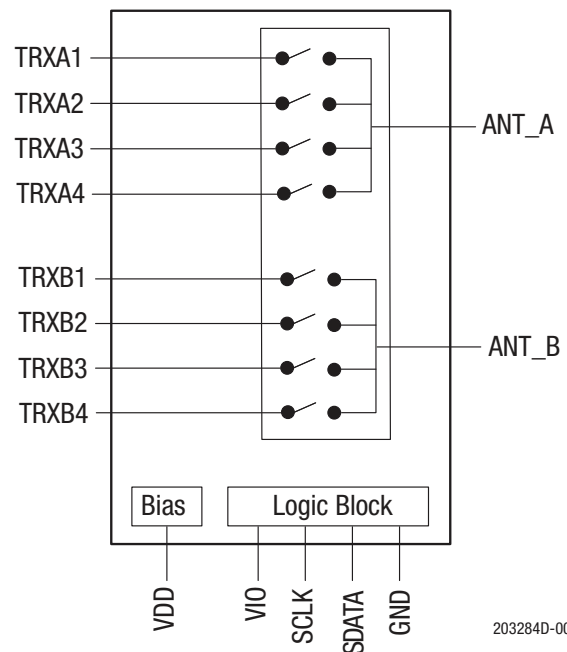

Figure 1. SKY13550-667LF Block Diagram

Switching is controlled by an integrated MIPI decoder. The two switches can be configured independently. There are separate registers for each SP4T. No external DC blocking capacitors are required on the RF paths as long as no DC voltage is applied to those paths.

The SKY13550-667LF is manufactured in a compact, 1.6 x 2.0 x 0.55 mm, 14-pin surface-mount Quad Flat No-Lead (QFN) package.

A functional block diagram is shown in Figure 1. The pin configuration and package are shown in Figure 2. Signal pin assignments and functional pin descriptions are provided in Table 1.

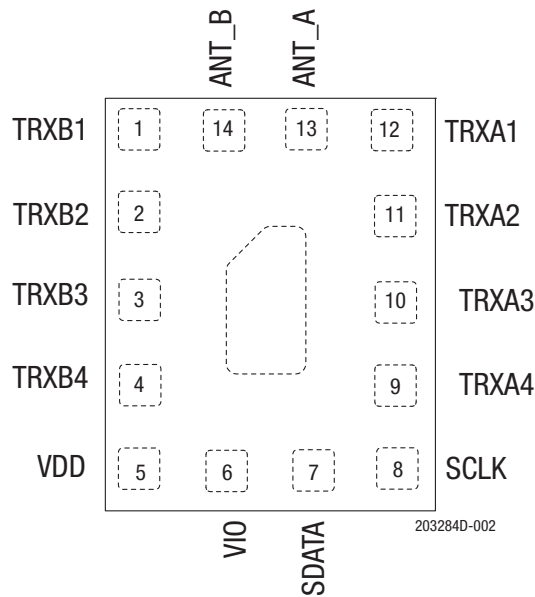

Figure 2. SKY13550-667LF Pinout (Top View)

Table 1. SKY13550-667LF Signal Descriptions¹

Pin	Name	Description	Pin	Name	Description
1	TRXB1	ANT_B transmit/receive arm 1	8	SCLK	Clock
2	TRXB2	ANT_B transmit/receive arm 2	9	TRXA4	ANT_A transmit/receive arm 4
3	TRXB3	ANT_B transmit/receive arm 3	10	TRXA3	ANT_A transmit/receive arm 3
4	TRXB4	ANT_B transmit/receive arm 4	11	TRXA2	ANT_A transmit/receive arm 2
5	VDD	DC supply voltage	12	TRXA1	ANT_A transmit/receive arm 1
6	VIO	MIPI interface DC voltage	13	ANT_A	Antenna A port
7	SDATA	Data	14	ANT_B	Antenna B port

¹ Bottom ground paddles must be connected to ground.

Electrical and Mechanical Specifications

The absolute maximum ratings of the SKY13550-667LF are provided in Table 2. Electrical specifications are provided in Tables 3 and 4.

IMD2 and IMD3 test conditions for various frequencies are listed in Tables 5 and 6, respectively.

Figure 3 illustrates the test setup used to measure intermodulation products. This industry standardized test is used to simulate the WCDMA linearity of the antenna switch. A +20 dBm Continuous Wave (CW) signal, f_{FUND} , is sequentially applied to the TRX ports, while a -15 dBm CW blocker signal, f_{BLK} , is applied to the ANT port.

The resulting third order intermodulation distortion (IMD3), f_{RX} , is measured over all phases of f_{FUND} . The SKY13550-667LF exhibits exceptional performance for all RF ports.

Table 7 describes the register content and programming read/write sequences. Refer to the *MIPI Alliance Specification for RF Front-End Control Interface (RFFE)*, v1.10 (26 July 2011) for additional information on MIPI programming sequences and MIPI bus specifications.

Figure 4 provides the timing diagram for register write commands. Figure 5 provides the timing diagram for register read commands.

Register descriptions and programming information is provided in Table 8. Tables 9 and 10 provide the Register_0 and Register_1 logic, respectively.

Table 2. SKY13550-667LF Absolute Maximum Ratings¹

Parameter	Symbol	Minimum	Maximum	Units
Supply voltage	VDD	2.5	5.0	V
Digital control signal	VIO		2	V
SCLK port voltage	SCLK		VIO	V
SDATA port voltage	SDATA		VIO	V
LTE input power	PIN		+31	dBm
Storage temperature	TSTG	-55	+150	°C
Operating temperature	TOP	-30	+90	°C

¹ Exposure to maximum rating conditions for extended periods may reduce device reliability. There is no damage to device with only one parameter set at the limit and all other parameters set at or below their nominal value. Exceeding any of the limits listed here may result in permanent damage to the device.

CAUTION: Although this device is designed to be as robust as possible, electrostatic discharge (ESD) can damage this device. This device must be protected at all times from ESD. Static charges may easily produce potentials of several kilovolts on the human body or equipment, which can discharge without detection. Industry-standard ESD precautions should be used at all times.

Table 3. SKY13550-667LF RF Electrical Specifications¹ (1 of 2)
(V_{DD} = 2.85 V, T_{OP} = +25 °C, Characteristic Impedance [Z₀] = 50 Ω, Unless Otherwise Noted)

Parameter	Symbol	Test Condition	Min	Typical	Max	Units	
Operating frequency	f		0.4		3.8	GHz	
Insertion loss	IL	ANT_A to any TRXA port, ANT_B to any TRXB port:					
		400 to 824 MHz		0.35	0.55	dB	
		824 to 960 MHz		0.4	0.6	dB	
		1427 to 1511 MHz		0.5	0.7	dB	
		1710 to 2170 MHz		0.65	0.8	dB	
		2170 to 2690 MHz		0.8	0.95	dB	
		3400 to 3800 MHz		1.4	1.6	dB	
Isolation	Iso	ANT_A to any OFF TRXA port, ANT_B to any OFF TRXB port:					
		Up to 787 MHz	33	36		dB	
		Up to 960 MHz	32	34		dB	
		Up to 1511 MHz	25	29		dB	
		Up to 1990 MHz	24	27		dB	
		Up to 2170 MHz	23	26		dB	
		Up to 2690 MHz	21	23		dB	
		Up to 3800 MHz	17	19		dB	
		ANT_A to any TRxB port, ANT_B to any TRxA port:					
		Up to 704 MHz	41	43		dB	
		Up to 960 MHz	39	41		dB	
		Up to 1511 MHz	35	37		dB	
		Up to 1990 MHz	33	35		dB	
		Up to 2170 MHz	32	34		dB	
		Up to 2690 MHz	30	32		dB	
		Up to 3800 MHz	25	27		dB	
		ANT_A to ANT_B:					
		400 to 960 GHz	32	34		dB	
1427 to 1511 MHz	28	30		dB			
1710 to 1980 GHz	26	28		dB			
1980 to 2690 MHz	23	25		dB			
3400 to 3800 GHz	20	22		dB			

Table 3. SKY13550-667LF RF Electrical Specifications¹ (2 of 2)
(V_{DD} = 2.85 V, T_{OP} = +25 °C, Characteristic Impedance [Z₀] = 50 Ω, Unless Otherwise Noted)

Parameter	Symbol	Test Condition	Min	Typical	Max	Units
ON state match	VSWR	400 to 2170 MHz		1.2:1	1.5:1	
Second order intermodulation distortion	IMD2	See Table 5		-110	-105	dBm
Third order intermodulation distortion	IMD3	See Table 6		-110	-105	dBm
Low band 2 nd and 3 rd harmonic	2fo, 3fo	Any TRX port, P _{IN} = +25 dBm, f = 900 MHz		-70	-65	dBm
Low band 2 nd and 3 rd harmonic	2fo, 3fo	Any TRX port, P _{IN} = +25 dBm, f ₀ = 900 MHz, VSWR = 5:1		-65	-60	dBm
Mid band 2 nd and 3 rd harmonic	2fo, 3fo	Any TRXA and any TRXB port, P _{IN} = +26 dBm, f ₁ = 1462 MHz, f ₂ = 1910 MHz		-70	-65	dBm
Mid band 2 nd and 3 rd harmonic	2fo, 3fo	Any TRXA and any TRXB port, P _{IN} = +26 dBm, f ₁ = 1462 MHz, f ₂ = 1910 MHz, VSWR = 5:1		-63	-60	dBm
High band 2 nd and 3 rd harmonic	2fo, 3fo	Any TRXA and any TRXB port, P _{IN} = +25 dBm, f ₀ = 2690 MHz		-70	-65	dBm
High band 2 nd and 3 rd harmonic	2fo, 3fo	Any TRXA and any TRXB port, P _{IN} = +25 dBm, f ₀ = 2690 MHz, VSWR = 5:1		-62	-60	dBm
Band 13 2 nd harmonic	2fo	Any TRX port, P _{IN} = +25 dBm, f ₀ = 777 to 787 MHz		-81		dBm
Band 17 3 rd harmonic	3fo	Any TRX port, P _{IN} = +25 dBm, f = 707 MHz		-80		dBm
Turn-on time	t _{ON}	From application of V _{DD} and V _{IO} , or transition from low power mode		4	10	μs
Wake-up time	t _w	From isolation state		2	5	μs
Switching speed	t _s	Any state to any other state		2	5	μs

¹ Performance is guaranteed only under the conditions listed in this table.

Table 4. SKY13550-667LF DC Electrical Specifications¹
 (V_{DD} = 2.85 V, V_{IO} = 1.8 V, T_{OP} = +25 °C, Characteristic Impedance [Z₀] = 50 Ω, Unless Otherwise Noted)

Parameter	Symbol	Test Condition	Min	Typical	Max	Units
Supply voltage	V _{DD}		2.50	2.85	4.8	V
Supply current, active mode	I _{DD}			50	100	μA
Interface supply voltage level	V _{IO}		1.65	1.80	1.95	V
Digital data and clock signals: High Low	SDATA, SCLK		0.8 × V _{IO} 0		V _{IO} 0.2 × V _{IO}	V V
Interface supply current	I _{vio}			5	50	μA

¹ Performance is guaranteed only under the conditions listed in this table.

Table 5. IMD2 Test Conditions

Band	Transmit Frequency (MHz)	Transmit Power (dBm)	Frequency Blocker, Low (MHz)	Frequency Blocker, High (MHz)	Power Blocker (dBm)	Receive Frequency (MHz)
1	1950.0	+20	190	4090	-15	2140.0
2	1880.0		80	3840		1960.0
4	1732.0		400	3864		2132.0
5	836.5		45	1718		881.5
7	2535.0		120	5190		2655.0
8	897.0		45	1839		942.0
11/21	1452.0			2952		1500

Table 6. IMD3 Test Conditions

Band	Transmit Frequency (MHz)	Transmit Power (dBm)	Frequency Blocker (MHz)	Power Blocker (dBm)	Receive Frequency (MHz)
1	1950.0	+20	1760.0	-15	2140.0
2	1880.0		1800.0		1960.0
4	1732.0		1332.0		2132.0
5	836.5		791.5		881.5
7	2535.0		2415.0		2655.0
8	897.0		852.0		942.0
11/21	1452		1404		1500

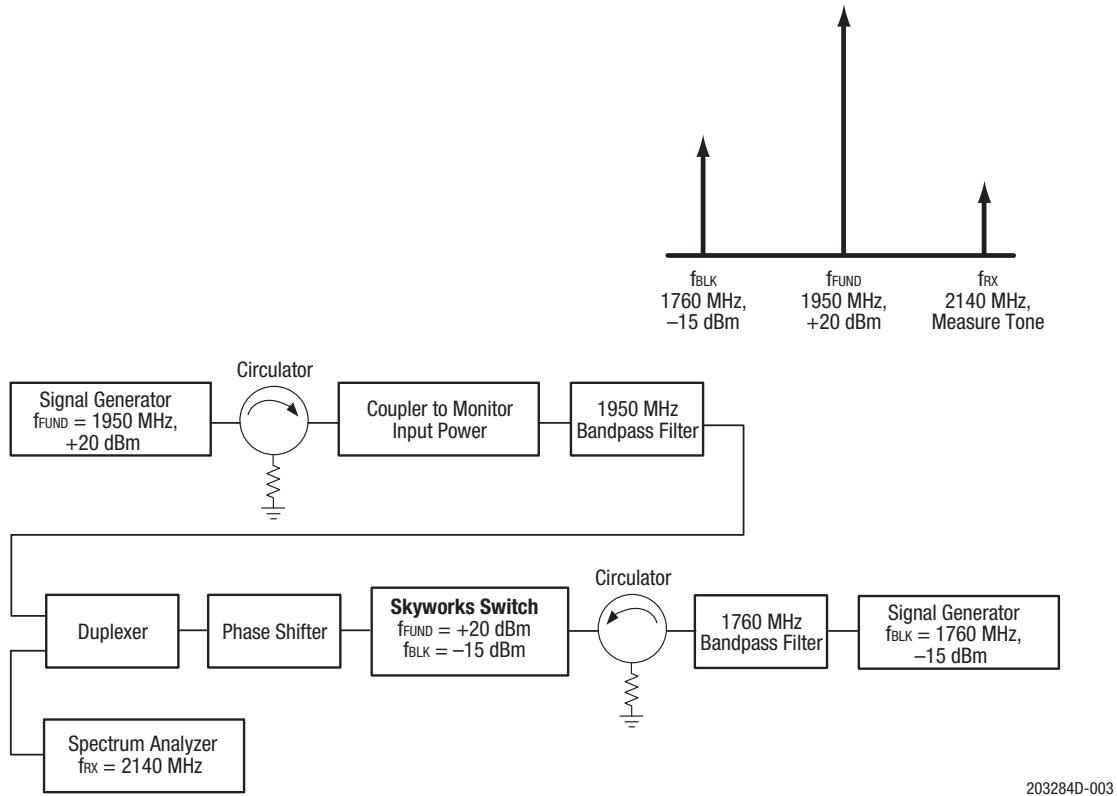

203284D-003

Figure 3. Typical Third Order Intermodulation Test Setup

Table 7. Command Sequence Bit Definitions

Type	SSC	C11-C8	C7	C6-C5	C4	C3-C0	Parity Bits	BPC	Extended Operation					
									DA7(1)-DA0(1)	Parity Bits	BPC	DA7(n)-DA0(n)	Parity Bits	BPC
Reg_0 Write, Short Command	Y	SA[3:0]	1b	Data[6:5]	Data[4]	Data[3:0]	Y	Y	-	-	-	-	-	-
Reg_0 Write, Long Command	Y	SA[3:0]	0	10b	Addr[4]	Addr[3:0]	Y	-	Data[7:0]	-	-	-	Y	Y
Reg_1 Write	Y	SA[3:0]	0	10b	Addr[4]	Addr[3:0]	Y	-	Data[7:0]	-	-	-	Y	Y
Reg Read	Y	SA[3:0]	0	11b	Addr[4]	Addr[3:0]	Y	Y	Data[7:0]	-	-	-	Y	Y

Legend:

SSC = Sequence start command
C = Command frame bits

DA = Data/address frame bits
BPC = Bus park cycle

BC = Byte count (number of consecutive addresses)

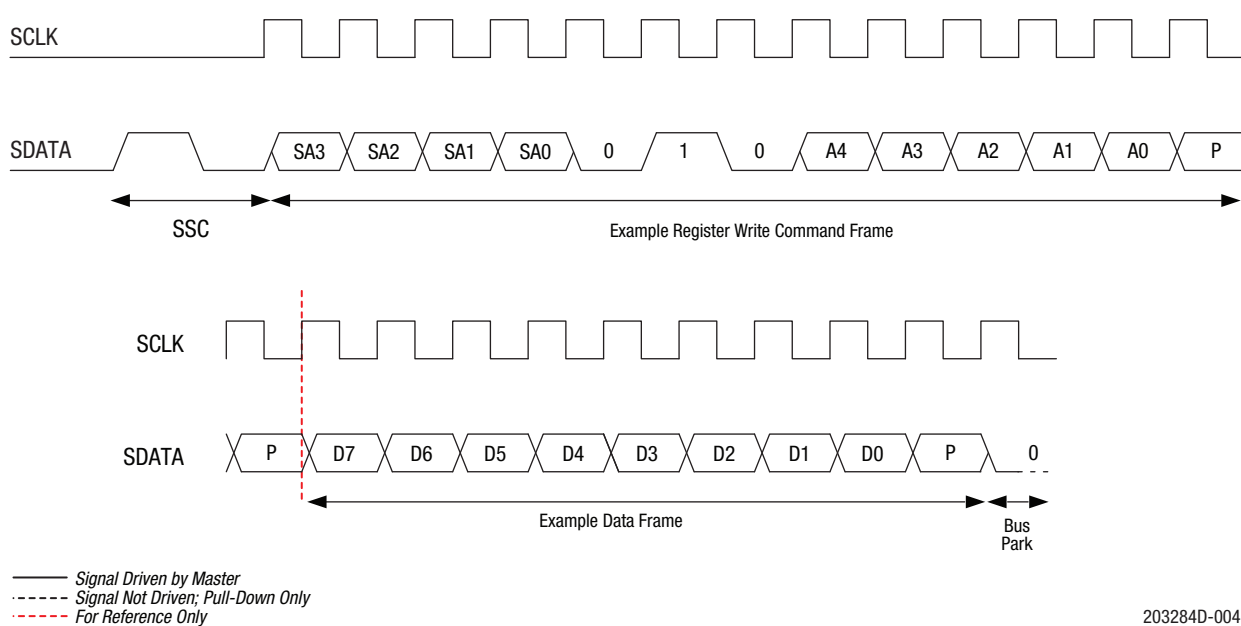

Figure 4. Register Write Command Timing Diagram

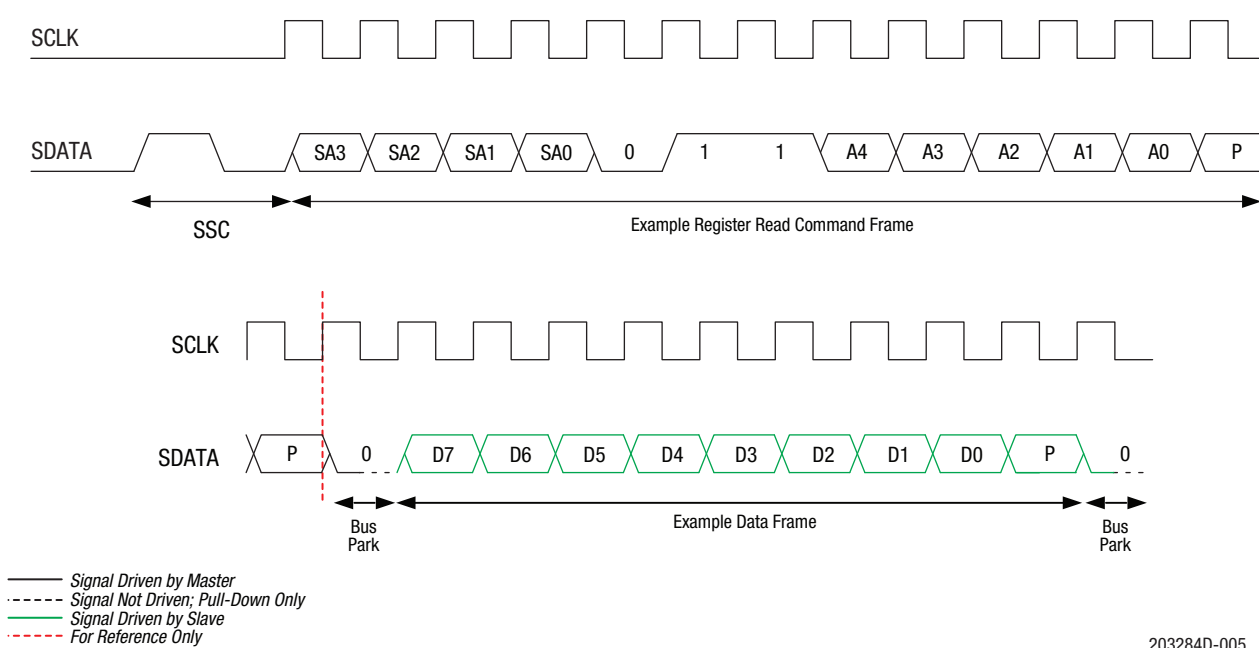

Figure 5. Register Read Command Timing Diagram

Table 8. Register Description and Programming¹

Register		Parameter	Description	Default (Binary)
Name	Address (Hex)			
Register_0	0000	MODE_CTRL	Bits[6:0]: See Table 10 for logic	0000000
Register_1	0001	MODE_CTRL	Bits[7:0]: See Table 11 for logic	00000000
PM_TRIG (Note 1)	001C	PWR_MODE	Bits[7:6]: 00 = Normal operation (active) 01 = Default settings (startup) 10 = Low power (low power) 11 = Reserved	00
		Trigger_Mask_2	Bit[5]: If this bit is set, trigger 2 is disabled. When all triggers are disabled, if writing to a register that is associated with trigger 2, the data goes directly to the destination register.	0
		Trigger_Mask_1	Bit[4]: If this bit is set, trigger 1 is disabled. When all triggers are disabled, if writing to a register that is associated with trigger 1, the data goes directly to the destination register.	0
		Trigger_Mask_0	Bit[3]: If this bit is set, trigger 0 is disabled. When all triggers are disabled, if writing to a register that is associated with trigger 0, the data goes directly to the destination register.	0
		Trigger_2	Bit[2]: If this bit is set, data is loaded into the trigger 2 registers.	0
		Trigger_1	Bit[1]: If this bit is set, data is loaded into the trigger 1 registers.	0
		Trigger_0	Bit[0]: If this bit is set, data is loaded into the trigger 0 registers.	0
PRODUCT_ID	001D	PRODUCT_ID	Bits[7:0]: This is a read-only register. However, during the programming of the Unique Slave Identifier (USID), a write command sequence is performed on this register but the value is not changed.	11010011
MANUFACTURER_ID	001E	MANUFACTURER_ID	Bits[7:0]: Read-only register	10100101
MAN_USID	001F	Reserved	Bits[7:6]: Reserved	00
		MANUFACTURER_ID	Bits[5:4]: Read-only register	01
		USID	Bits[3:0]: Programmable USID. A write to these bits programs the USID.	1010

¹ Unlike the complete independence between triggers 0, 1, and 2, and also between the associated trigger masks 0, 1, and 2, respectively, as described in the MIPI RFFE Specification, this device uses additional interactions between the provided trigger functions.

The delayed application of updated data to all triggerable registers in this device may be accomplished using any of the three triggers (0, 1, or 2), provided that the particular trigger used is not currently masked off. If multiple triggers are enabled, any or all of those are sufficient to cause the data to be transferred from shadow registers to destination registers for all triggerable registers in the device.

It is also necessary to disable all three triggers (i.e., set all three trigger masks) to ensure that data written to any triggerable register will immediately be written to the destination register at the conclusion of the RFFE command sequence where the data is written.

Table 9. Register_0 Truth Table (ANT_B)

ON State	Register 0 Bits							
	D7	D6	D5	D4	D3	D2	D1	D0
All isolation				0	0	0	0	0
TRXB1				0	0	0	0	1
TRXB2				0	0	0	1	0
TRXB3			μ	0	0	0	1	1
TRXB4				0	0	1	0	0
Isolation				0	0	1	0	1
Isolation				0	0	1	1	0
Isolation				0	0	1	1	1
TRXB4				0	1	0	0	0
TRXB3				0	1	0	0	1
TRXB2				0	1	0	1	0
TRXB1				0	1	0	1	1
TRXB4				0	1	1	0	0
TRXB3				0	1	1	0	1
TRXB2				0	1	1	1	0
TRXB1				0	1	1	1	1
TRXB4+3				1	0	0	0	0
TRXB4+2				1	0	0	0	1
TRXB4+1				1	0	0	1	0
TRXB3+2				1	0	0	1	1
TRXB3+1				1	0	1	0	0
TRXB2+1				1	0	1	0	1
All isolation				1	0	1	1	0
All isolation				1	0	1	1	1
All isolation				1	1	0	0	0
All isolation				1	1	0	0	1
All isolation				1	1	0	1	0
All isolation				1	1	0	1	1
All isolation				1	1	1	0	0
All isolation				1	1	1	0	1
All isolation				1	1	1	1	0
All isolation				1	1	1	1	1

Table 10. Register_1 Truth Table (ANT_A)

Mode	Register 1 Bits							
	D7	D6	D5	D4	D3	D2	D1	D0
All isolation				0	0	0	0	0
TRXA1				0	0	0	0	1
TRXA2				0	0	0	1	0
TRXA3				0	0	0	1	1
TRXA4				0	0	1	0	0
Isolation				0	0	1	0	1
Isolation				0	0	1	1	0
Isolation				0	0	1	1	1
TRXA4				0	1	0	0	0
TRXA3				0	1	0	0	1
TRXA2				0	1	0	1	0
TRXA1				0	1	0	1	1
TRXA4				0	1	1	0	0
TRXA3				0	1	1	0	1
TRXA2				0	1	1	1	0
TRXA1				0	1	1	1	1
TRXA4+3				1	0	0	0	0
TRXA4+2				1	0	0	0	1
TRXA4+1				1	0	0	1	0
TRXA3+2				1	0	0	1	1
TRXA3+1				1	0	1	0	0
TRXA2+1				1	0	1	0	1
All isolation				1	0	1	1	0
All isolation				1	0	1	1	1
All isolation				1	1	0	0	0
All isolation				1	1	0	0	1
All isolation				1	1	0	1	0
All isolation				1	1	0	1	1
All isolation				1	1	1	0	0
All isolation				1	1	1	0	1
All isolation				1	1	1	1	0
All isolation				1	1	1	1	1

Evaluation Board Description

The SKY13550-667LF Evaluation Board is used to test the performance of the SKY13550-667LF DP8T Switch. An Evaluation Board schematic diagram is provided in Figure 6. A recommended ESD protection circuit diagram is provided in Figure 7. An assembly drawing for the Evaluation Board is shown in Figure 8.

Package Dimensions

The PCB layout footprint for the SKY13550-667LF is provided in Figure 9. Typical part markings are shown in Figure 10. Package dimensions are shown in Figure 11, and tape and reel dimensions are provided in Figure 12.

Package and Handling Information

Instructions on the shipping container label regarding exposure to moisture after the container seal is broken must be followed. Otherwise, problems related to moisture absorption may occur when the part is subjected to high temperature during solder assembly.

The SKY13550-667LF is rated to Moisture Sensitivity Level 1 (MSL1) at 260 °C. It can be used for lead or lead-free soldering. For additional information, refer to the Skyworks Application Note, *Solder Reflow Information*, document number 200164.

Care must be taken when attaching this product, whether it is done manually or in a production solder reflow environment. Production quantities of this product are shipped in a standard tape and reel format.

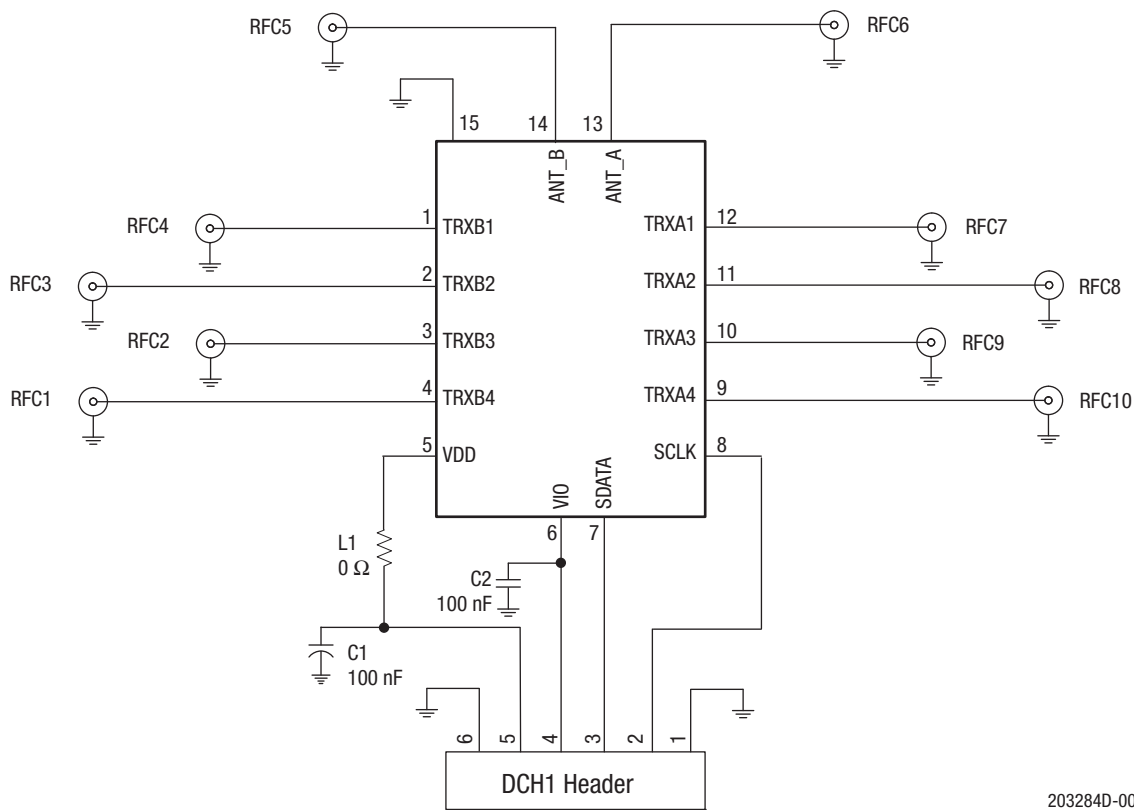

203284D-006

Figure 6. SKY13550-667LF Evaluation Board Schematic

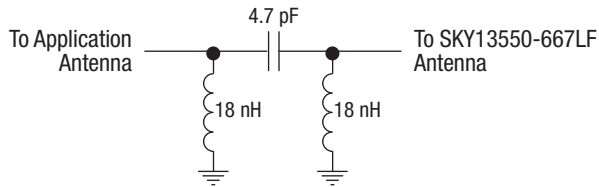

ESD Circuit 1

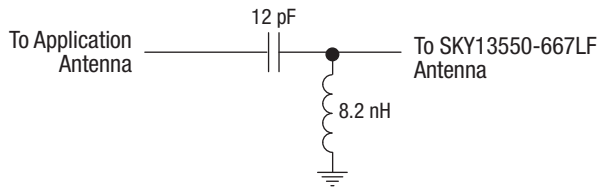

ESD Circuit 2

203284D-007

Figure 7. SKY13550-667LF Recommended ESD Protection Circuits

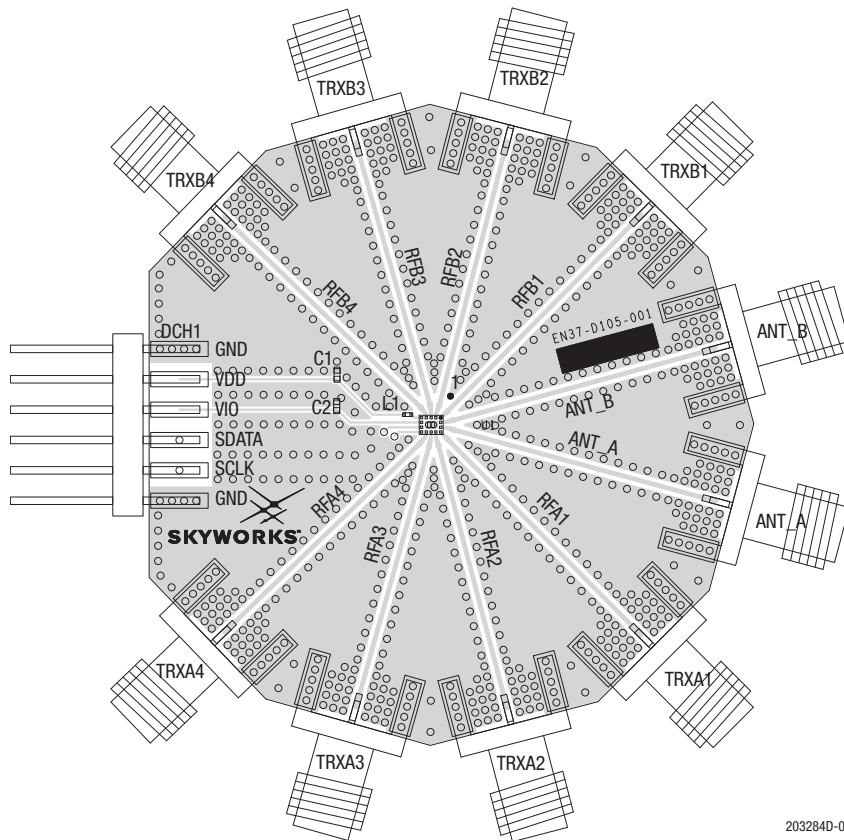

203284D-008

Figure 8. SKY13550-667LF Evaluation Board Assembly Diagram

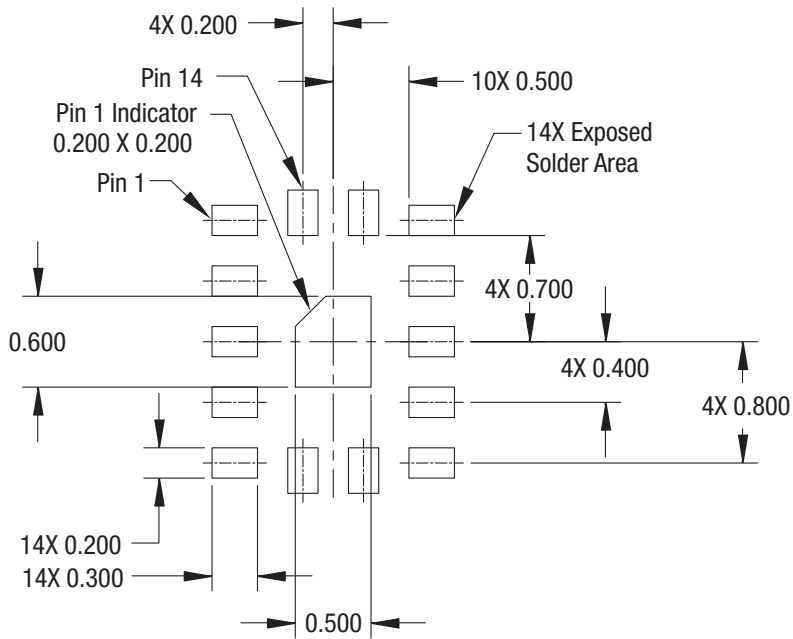

Dimensions are in millimeters

203284D-009

Figure 9. SKY13550-667LF PCB Layout Footprint (Top View)

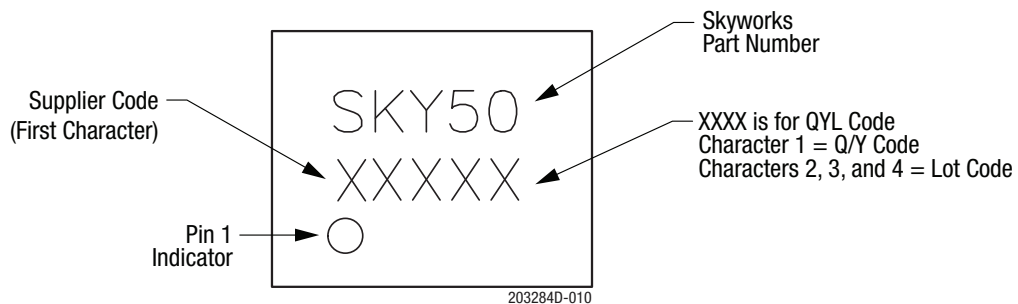

203284D-010

Figure 10. Typical Part Markings (Top View)

DATA SHEET • SKY13550-667LF: DP8T RECEIVE MAIN/DIVERSITY SWITCH FOR CARRIER AGGREGATION

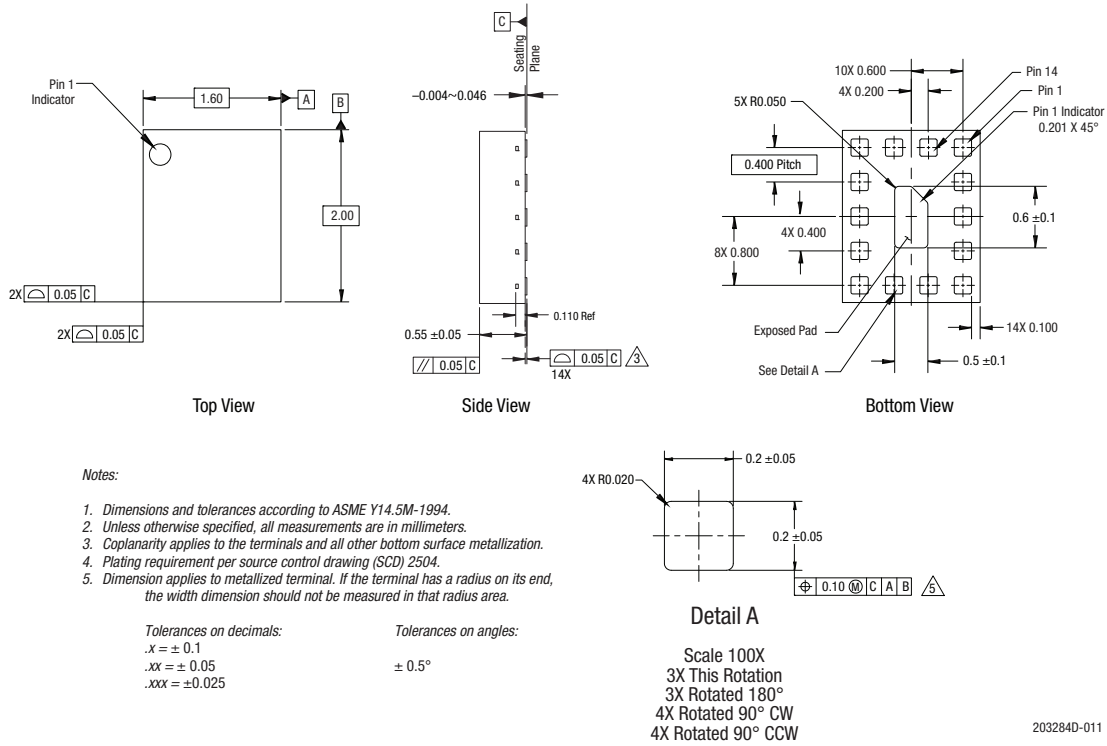

Figure 11. SKY13550-667LF Package Dimensions

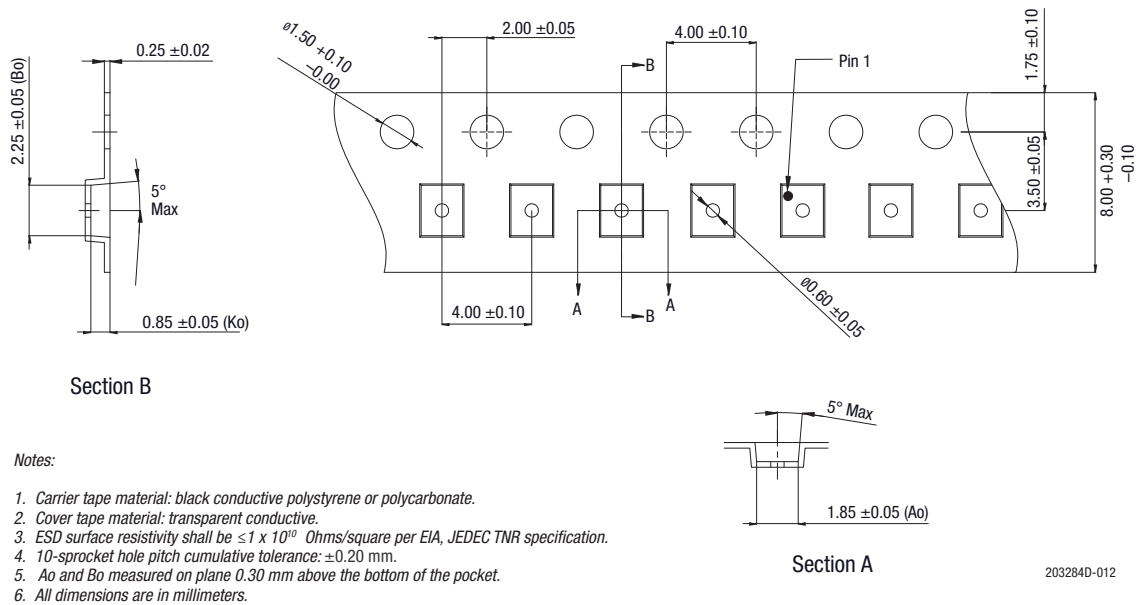

Figure 12. SKY13550-667LF Tape and Reel Dimensions

Ordering Information

Model Name	Manufacturing Part Number	Evaluation Board Part Number
SKY13550-667LF: 0.4 to 3.8 GHz DP8T Switch	SKY13550-667LF	SKY13550-667LF-EVB

Copyright © 2014-2016 Skyworks Solutions, Inc. All Rights Reserved.

Information in this document is provided in connection with Skyworks Solutions, Inc. (“Skyworks”) products or services. These materials, including the information contained herein, are provided by Skyworks as a service to its customers and may be used for informational purposes only by the customer. Skyworks assumes no responsibility for errors or omissions in these materials or the information contained herein. Skyworks may change its documentation, products, services, specifications or product descriptions at any time, without notice. Skyworks makes no commitment to update the materials or information and shall have no responsibility whatsoever for conflicts, incompatibilities, or other difficulties arising from any future changes.

No license, whether express, implied, by estoppel or otherwise, is granted to any intellectual property rights by this document. Skyworks assumes no liability for any materials, products or information provided hereunder, including the sale, distribution, reproduction or use of Skyworks products, information or materials, except as may be provided in Skyworks Terms and Conditions of Sale.

THE MATERIALS, PRODUCTS AND INFORMATION ARE PROVIDED “AS IS” WITHOUT WARRANTY OF ANY KIND, WHETHER EXPRESS, IMPLIED, STATUTORY, OR OTHERWISE, INCLUDING FITNESS FOR A PARTICULAR PURPOSE OR USE, MERCHANTABILITY, PERFORMANCE, QUALITY OR NON-INFRINGEMENT OF ANY INTELLECTUAL PROPERTY RIGHT; ALL SUCH WARRANTIES ARE HEREBY EXPRESSLY DISCLAIMED. SKYWORKS DOES NOT WARRANT THE ACCURACY OR COMPLETENESS OF THE INFORMATION, TEXT, GRAPHICS OR OTHER ITEMS CONTAINED WITHIN THESE MATERIALS. SKYWORKS SHALL NOT BE LIABLE FOR ANY DAMAGES, INCLUDING BUT NOT LIMITED TO ANY SPECIAL, INDIRECT, INCIDENTAL, STATUTORY, OR CONSEQUENTIAL DAMAGES, INCLUDING WITHOUT LIMITATION, LOST REVENUES OR LOST PROFITS THAT MAY RESULT FROM THE USE OF THE MATERIALS OR INFORMATION, WHETHER OR NOT THE RECIPIENT OF MATERIALS HAS BEEN ADVISED OF THE POSSIBILITY OF SUCH DAMAGE.

Skyworks products are not intended for use in medical, lifesaving or life-sustaining applications, or other equipment in which the failure of the Skyworks products could lead to personal injury, death, physical or environmental damage. Skyworks customers using or selling Skyworks products for use in such applications do so at their own risk and agree to fully indemnify Skyworks for any damages resulting from such improper use or sale.

Customers are responsible for their products and applications using Skyworks products, which may deviate from published specifications as a result of design defects, errors, or operation of products outside of published parameters or design specifications. Customers should include design and operating safeguards to minimize these and other risks. Skyworks assumes no liability for applications assistance, customer product design, or damage to any equipment resulting from the use of Skyworks products outside of stated published specifications or parameters.

Skyworks and the Skyworks symbol are trademarks or registered trademarks of Skyworks Solutions, Inc., in the United States and other countries. Third-party brands and names are for identification purposes only, and are the property of their respective owners. Additional information, including relevant terms and conditions, posted at www.skyworksinc.com, are incorporated by reference.



Стандарт Электрон Связь

Мы молодая и активно развивающаяся компания в области поставок электронных компонентов. Мы поставляем электронные компоненты отечественного и импортного производства напрямую от производителей и с крупнейших складов мира.

Благодаря сотрудничеству с мировыми поставщиками мы осуществляем комплексные и плановые поставки широчайшего спектра электронных компонентов.

Собственная эффективная логистика и склад в обеспечивает надежную поставку продукции в точно указанные сроки по всей России.

Мы осуществляем техническую поддержку нашим клиентам и предпродажную проверку качества продукции. На все поставляемые продукты мы предоставляем гарантию .

Осуществляем поставки продукции под контролем ВП МО РФ на предприятия военно-промышленного комплекса России , а также работаем в рамках 275 ФЗ с открытием отдельных счетов в уполномоченном банке. Система менеджмента качества компании соответствует требованиям ГОСТ ISO 9001.

Минимальные сроки поставки, гибкие цены, неограниченный ассортимент и индивидуальный подход к клиентам являются основой для выстраивания долгосрочного и эффективного сотрудничества с предприятиями радиоэлектронной промышленности, предприятиями ВПК и научно-исследовательскими институтами России.

С нами вы становитесь еще успешнее!

Наши контакты:

Телефон: +7 812 627 14 35

Электронная почта: sales@st-electron.ru

Адрес: 198099, Санкт-Петербург,
Промышленная ул, дом № 19, литера Н,
помещение 100-Н Офис 331