

DATA SHEET

SKY13492-21: 0.7 to 2.7 GHz SP16T MIPI® Antenna Switch Module

Applications

- 2G/3G/4G multimode cellular handsets (LTE, UMTS, CDMA2000, EDGE, GSM, TDD-LTE, TD-SCDMA)
- Embedded data cards

Features

- Dedicated Band 7 TRX ports: 0.90 dB insertion loss @ 2.7 GHz
- High isolation and linearity
- Broadband frequency range: 0.7 to 2.7 GHz
- Fourteen linear TRX ports
- Integrated low- and high-band GSM harmonic filters
- External MIPI select pin to enable multiple trigger controls
- Small MCM (24-pin, 2.5 x 3.3 x 0.8 mm) package (MSL3, 260 °C per JEDEC J-STD-020)



Skyworks Green™ products are compliant with all applicable legislation and are halogen-free. For additional information, refer to *Skyworks Definition of Green™*, document number SQ04-0074.

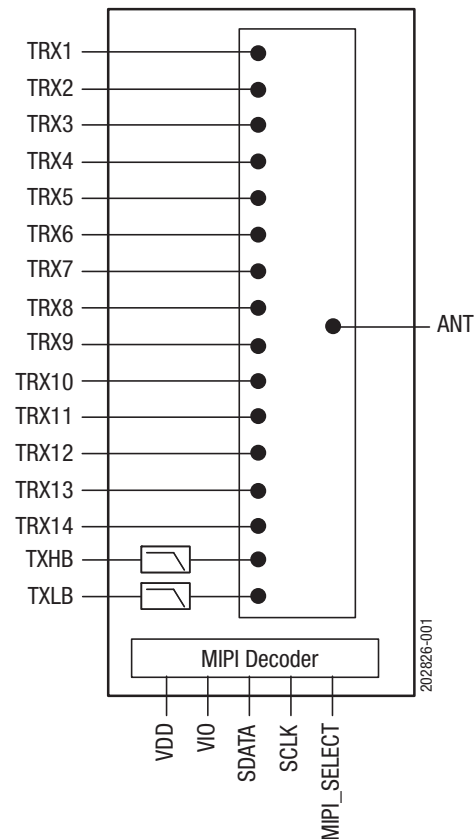

Figure 1. SKY13492-21 Block Diagram

Description

The SKY13492-21 is a single-pole, sixteen-throw (SP16T) antenna switch with an integrated Mobile Industry Processor Interface (MIPI) controller. Using an advanced switching technology, the SKY13492-21 maintains low insertion and high isolation, which makes it an ideal choice for UMTS, CDMA2000, EDGE, GSM, and LTE applications.

The design features two dedicated GSM transmit ports and three dedicated ultra low-loss TRX ports. The switch also has an excellent triple beat ratio and second/third order intermodulation distortion (IMD2/IMD3) performance.

Switching is controlled by the MIPI decoder. There is an external MIPI select pin that enables how the switch responds to power

mode triggers. When this pin is grounded, the switch responds to any of the power mode triggers. When this pin is left open, the switch responds to individual power mode triggers. No external DC blocking capacitors are required on the RF paths as long as no DC voltage is applied.

The SKY13492-21 is manufactured in a compact, 2.5 x 3.3 x 0.8 mm, 24-pin surface mount Multi-Chip Module (MCM) package.

A functional block diagram is shown in Figure 1. The pin configuration and package are shown in Figure 2. Signal pin assignments and functional pin descriptions are provided in Table 1.

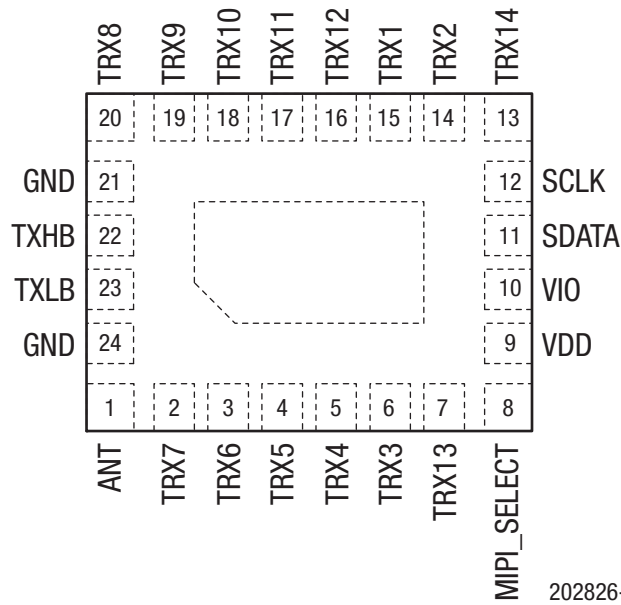

Figure 2. SKY13492-21 Pinout (Top View)

202826-002

Table 1. SKY13492-21 Signal Descriptions¹ (1 of 2)

Pin	Name	Description	Pin	Name	Description
1	ANT	Antenna port	8	MIP1_SELECT	MIPI interface select. When this pin is grounded, the switch responds to any of the power mode triggers. When this pin is left open, the switch is RFFE MIPI compliant and responds to individual power mode triggers.
2	TRX7	3G WCDMA transmit/receive port 7. This pin is either connected directly to or disconnected from pin 1, depending on the applied control data.	9	VDD	DC power supply
3	TRX6	3G WCDMA transmit/receive port 6. This pin is either connected directly to or disconnected from pin 1, depending on the applied control data.	10	VIO	MIPI decoder enable/reference voltage
4	TRX5	3G WCDMA transmit/receive port 5. This pin is either connected directly to or disconnected from pin 1, depending on the applied control data.	11	SDATA	Data input/output
5	TRX4	3G WCDMA transmit/receive port 4. This pin is either connected directly to or disconnected from pin 1, depending on the applied control data.	12	SCLK	Clock signal
6	TRX3	Ultra low-loss 3G WCDMA transmit/receive port 3. This pin is either connected directly to or disconnected from pin 1, depending on the applied control data.	13	TRX14	3G WCDMA transmit/receive port 14. This pin is either connected directly to or disconnected from pin 1, depending on the applied control data.
7	TRX13	3G WCDMA transmit/receive port 13. This pin is either connected directly to or disconnected from pin 1, depending on the applied control data.	14	TRX2	Ultra low-loss 3G WCDMA transmit/receive port 2. This pin is either connected directly to or disconnected from pin 1, depending on the applied control data.

Table 1. SKY13492-21 Signal Descriptions¹ (2 of 2)

Pin	Name	Description	Pin	Name	Description
15	TRX1	Ultra low-loss 3G WCDMA transmit/receive port 1. This pin is either connected directly to or disconnected from pin 1, depending on the applied control data.	20	TRX8	3G WCDMA transmit/receive port 8. This pin is either connected directly to or disconnected from pin 1, depending on the applied control data.
16	TRX12	3G WCDMA transmit/receive port 12. This pin is either connected directly to or disconnected from pin 1, depending on the applied control data.	21	GND	Ground
17	TRX11	3G WCDMA transmit/receive port 11. This pin is either connected directly to or disconnected from pin 1, depending on the applied control data.	22	TXHB	GSM transmit high band. This pin is either connected directly to or disconnected from pin 1, depending on the applied control data.
18	TRX10	3G WCDMA transmit/receive port 10. This pin is either connected directly to or disconnected from pin 1, depending on the applied control data.	23	TXLB	GSM transmit low band. This pin is either connected directly to or disconnected from pin 1, depending on the applied control data.
19	TRX9	3G WCDMA transmit/receive port 9. This pin is either connected directly to or disconnected from pin 1, depending on the applied control data.	24	GND	Ground

¹ Bottom ground paddles must be connected to ground.

Electrical and Mechanical Specifications

The absolute maximum ratings of the SKY13492-21 are provided in Table 2. Electrical specifications are provided in Tables 3 and 4. IMD2 and IMD3 test conditions for various frequencies are listed in Tables 5 and 6, respectively.

Triple beat ratio (TBR) test conditions for bands 2 and 5 are listed in Table 7.

Figure 3 shows a timing diagram. Figure 4 illustrates the test setup used to measure intermodulation products. This industry standardized test is used to simulate the WCDMA Band 1 linearity of the antenna switch. A +20 dBm continuous wave (CW) signal, f_{FUND} , is sequentially applied to the TRX1 through TRX14 ports, while a -15 dBm CW blocker signal, f_{BLK} , is applied to the ANT port.

The resulting third order intermodulation distortion (IMD3), f_{RX} , is measured over all phases of f_{FUND} . The SKY13492-21 exhibits exceptional performance for all TRXx ports.

Table 8 shows the isolation matrix for "On" to "Off" arms. Table 9 shows the isolation matrix for "Ant" to "Off" arms. Table 10 provides the matrix of insertion loss and return loss information. Table 11 describes the register content and programming read/write sequences. Refer to the *MIPI Alliance Specification for RF Front-End Control Interface (RFFE)*, v1.10 (26 July 2011) for additional information on MIPI programming sequences and MIPI bus specifications.

Figures 5 and 6 provide the timing diagrams for register write commands and read commands, respectively.

Table 12 provides the Register_0 logic. Table 13 describes the register parameters and bit values.

Table 2. SKY13492-21 Absolute Maximum Ratings¹

Parameter	Symbol	Minimum	Maximum	Units
Supply voltage	VDD	2.5	6.0	V
MIPI decoder enable/reference voltage	VIO		2	V
Clock signal voltage	SCLK		VIO	V
Data signal voltage	SDATA		VIO	V
RF input power: LTX pin HTX pin All TRXx pins ²	PIN		+36 +34 +31	dBm dBm dBm
Storage temperature	TSTG	-55	+150	°C
Operating temperature	TOP	-30	+90	°C

¹ Exposure to maximum rating conditions for extended periods may reduce device reliability. There is no damage to device with only one parameter set at the limit and all other parameters set at or below their nominal value. Exceeding any of the limits listed here may result in permanent damage to the device.

² RF input power for TRXx pins is evaluated with 25% duty cycle rectangular pulse wave.

ESD HANDLING: *Although this device is designed to be as robust as possible, electrostatic discharge (ESD) can damage this device. This device must be protected at all times from ESD when handling or transporting. Static charges may easily produce potentials of several kilovolts on the human body or equipment, which can discharge without detection. Industry-standard ESD handling precautions should be used at all times.*

Table 3. SKY13492-21 DC Electrical Specifications¹

(VDD = 2.85 V, TOP = +25 °C, Characteristic Impedance [Zo] = 50 Ω, Unless Otherwise Noted)

Parameter	Symbol	Test Condition	Min	Typical	Max	Units
Supply voltage	VDD		2.50	2.85	6.00	V
Supply current, active mode	IDD			45	85	μA
Interface supply voltage	VIO		1.65	1.80	1.95	V
Interface signal: High Low	SDATA		0.8 × VIO		0.2 × VIO	V V
Control current: High Low				1 1	5 5	μA μA

¹ Performance is guaranteed only under the conditions listed in this table.

Table 4. SKY13492-21 RF Electrical Specifications¹ (1 of 2)
(V_{DD} = 2.85 V, T_{OP} = +25 °C, Characteristic Impedance [Z₀] = 50 Ω, Unless Otherwise Noted)

Parameter	Symbol	Test Condition	Min	Typical	Max	Units
Operating frequency	f		0.7		2.7	GHz
Insertion loss	IL	TXLB, 824 to 915 MHz		1.35	1.50	dB
		TXHB, 1710 to 1910 MHz		1.25	1.40	dB
		TRX1 to TRX14 ports (except TRX7): 700 to 824 MHz		0.55	0.80	dB
		824 to 960 MHz		0.65	0.90	dB
		1710 to 1990 MHz		0.80	0.95	dB
		TRX4 to TRX14 ports (except TRX7): 2110 to 2170 MHz		0.90	1.05	dB
		2300 to 2690 MHz		0.90	1.15	dB
		TRX1/2/3 ports: 2110 to 2170 MHz		0.80	1.00	dB
		2300 to 2690 MHz		0.90	1.10	dB
		TRX7 port: 824 to 960 MHz		0.70	0.90	dB
1710 to 1990 MHz		0.90	1.05	dB		
2110 to 2170 MHz		1.15	1.25	dB		
2300 to 2690 MHz		1.15	1.25	dB		
GSM LB TX: 2f0 attenuation 3f0 attenuation 4f0 attenuation	H2LB	2f0 attenuation 1830 MHz	22	24		dB
	H3LB	3f0 attenuation 2745 MHz	23	27		dB
	H4LB	4f0 attenuation 3660 MHz	30	35		dB
GSM HB TX: 2f0 attenuation 3f0 attenuation	H2HB	2f0 attenuation 3820 MHz	20	22		dB
	H3HB	3f0 attenuation 5730 MHz	17	19		dB
Isolation (TRXx to any off TRXx port [non-adjacent ports]) (See Table 8 for full matrix)	Iso	824 to 1910 MHz	25	28		dB
		1910 to 2690 MHz	20	23		dB
Isolation (TRXx to any off TRXx port [adjacent ports]) (See Table 8 for full matrix)	Iso	824 to 1910 MHz	20	23		dB
		1910 to 2690 MHz	17	20		dB
On state match	Return Loss	0.7 to 2.7 GHz	14	18		dB
GSM harmonics: High band	2fo, 3fo	PIN = +33 dBm, 50 Ω		-51	-48	dBm
		PIN = +33 dBm, 3:1 VSWR		-36		dBm
Low band	2fo, 3fo	PIN = +35 dBm, 50 Ω		-60	-55	dBm
		PIN = +35 dBm, 3:1 VSWR		-36		dBm
TRXx harmonics	2fo, 3fo	PIN = +25 dBm, 50 Ω, f = 704 to 2700 MHz		-63	-59	dBm
		PIN = +25 dBm, 5:1 VSWR, f = 704 to 2700 MHz			-40	dBm

Table 4. SKY13492-21 RF Electrical Specifications¹ (2 of 2)
(V_{DD} = 2.85 V, T_{OP} = +25 °C, Characteristic Impedance [Z₀] = 50 Ω, Unless Otherwise Noted)

Parameter	Symbol	Test Condition	Min	Typical	Max	Units
TRX1 through TRX14, band 13 2 nd harmonics	2fo	PIN = +25 dBm, f = 787 MHz			-78	dBm
Second order intermodulation distortion	IMD2	See test conditions in Table 5		-104	-102	dBm
Third order intermodulation distortion	IMD3	See test conditions in Table 6		-110	-105	dBm
Triple beat ratio: 650 to 900 MHz 1710 to 2155 MHz	TBR	See test conditions in Table 7	+81 +81			dBc dBc
Turn-on time (see Figure 3)	ton	From application of V _{DD} and V _{IO}			20	μs
Switching speed (see Figure 3)	ts	Port to port		2	5	μs

¹ Performance is guaranteed only under the conditions listed in this table.

Table 5. IMD2 Test Conditions

Band	Transmit Frequency (MHz)	Transmit Power (dBm)	Frequency Blocker, Low (MHz)	Frequency Blocker, High (MHz)	Power Blocker (dBm)	Receive Frequency (MHz)
1	1950.0	+20	190	4090	-15	2140.0
2	1880.0		80	3840		1960.0
4	1732.0		400	3864		2132.0
5	836.5		45	1718		881.5
7	2535.0		120	5187		2655.0
8	897.0		45	1839		942.0

Table 6. IMD3 Test Conditions

Band	Transmit Frequency (MHz)	Transmit Power (dBm)	Frequency Blocker (MHz)	Power Blocker (dBm)	Receive Frequency (MHz)
1	1950.0	+20	1760.0	-15	2140.0
2	1880.0		1800.0		1960.0
4	1732.0		1332.0		2132.0
5	836.5		791.5		881.5
7	2535.0		2415.0		2655.0
8	897.0		852.0		942.0

Table 7. Triple Beat Ratio Test Conditions

Band	Transmit Frequency 1 (MHz)	Transmit Power 1 (dBm)	Transmit Frequency 2 (MHz)	Transmit Power 2 (dBm)	Frequency Blocker @ ANT (MHz)	Power Blocker (dBm)	TBR Product Frequency (MHz)
2	1880.0	+21.5	1881.0	+21.5	1960.0	-30	1960.0 ± 1
5	836.5		837.5		881.5		881.5 ± 1

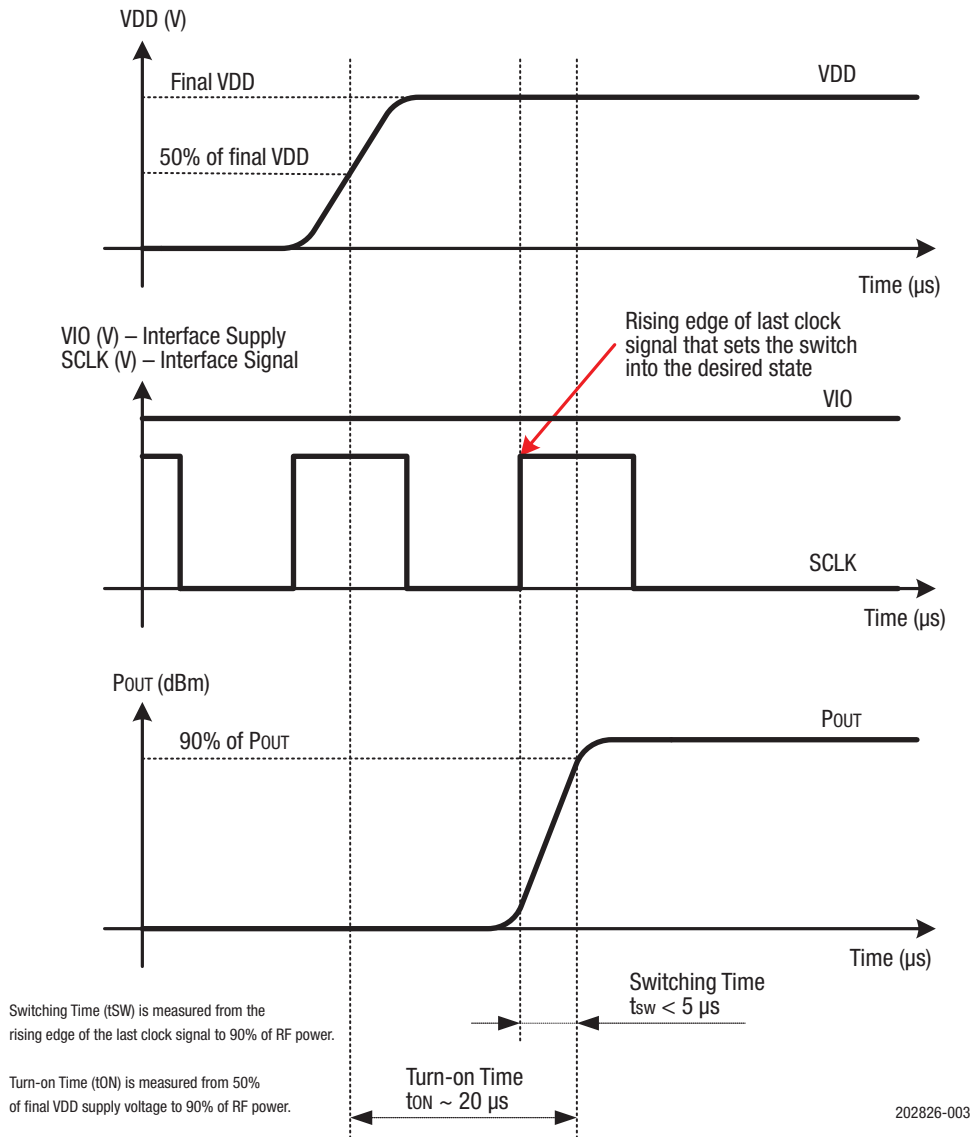

Figure 3. SKY13492-21. Timing Diagram

Table 8. SKY13492-21: Isolation Matrix: Isolation “On” Arms to “Off” Arms (1 of 2)

“On” Arms	Freq (MHz)	Isolation (dB)															
		LTX	HTX	TRX1	TRX2	TRX3	TRX4	TRX5	TRX6	TRX7	TRX8	TRX9	TRX10	TRX11	TRX12	TRX13	TRX14
LTX	915		-31	-52	-51	-46	-42	-45	-45	-41	-46	-49	-51	-51	-52	-55	-54
LTX	1910		-26	-51	-52	-43	-42	-47	-43	-37	-37	-41	-44	-45	-49	-53	-46
LTX	2690		-16	-47	-48	-42	-41	-42	-39	-34	-33	-37	-40	-41	-44	-48	-44
HTX	915	-33		-48	-46	-53	-53	-53	-51	-46	-37	-41	-44	-57	-53	-50	-52
HTX	1910	-23		-42	-38	-45	-45	-45	-43	-37	-32	-36	-38	-47	-53	-42	-43
HTX	2690	-17		-49	-40	-49	-49	-49	-48	-47	-33	-38	-41	-33	-39	-52	-47
TRX1	915	-35	-50		-29	-52	-54	-55	-53	-49	-54	-49	-46	-43	-34	-39	-50
TRX1	1910	-34	-33		-22	-42	-43	-43	-42	-38	-42	-41	-39	-36	-27	-31	-41
TRX1	2690	-28	-30		-19	-38	-39	-38	-38	-34	-37	-37	-35	-32	-24	-27	-37
TRX2	915	-35	-55	-37		-51	-53	-54	-53	-49	-55	-51	-49	-48	-40	-36	-48
TRX2	1910	-34	-34	-29		-41	-43	-42	-42	-37	-43	-42	-41	-39	-32	-28	-39
TRX2	2690	-28	-31	-26		-37	-38	-38	-37	-34	-37	-38	-37	-35	-28	-24	-36
TRX3	915	-33	-54	-55	-52		-29	-37	-42	-45	-57	-58	-59	-58	-57	-48	-36
TRX3	1910	-31	-35	-47	-44		-23	-31	-35	-34	-44	-46	-48	-46	-47	-39	-29
TRX3	2690	-27	-32	-42	-39		-20	-28	-32	-31	-38	-41	-43	-41	-41	-35	-25
TRX4	915	-32	-51	-55	-52	-34		-29	-38	-43	-57	-58	-59	-57	-56	-49	-39
TRX4	1910	-31	-35	-46	-43	-28		-23	-31	-33	-44	-46	-47	-45	-46	-40	-32
TRX4	2690	-27	-32	-41	-38	-25		-20	-28	-29	-38	-41	-43	-40	-41	-35	-28
TRX5	915	-33	-48	-54	-52	-41	-34		-29	-36	-56	-57	-57	-55	-55	-50	-46
TRX5	1910	-32	-35	-45	-42	-35	-27		-22	-28	-44	-46	-47	-45	-45	-40	-38
TRX5	2690	-28	-33	-41	-38	-32	-25		-19	-24	-38	-41	-42	-40	-41	-36	-35
TRX6	915	-34	-46	-53	-51	-45	-41	-33		-30	-55	-56	-55	-54	-54	-50	-48
TRX6	1910	-35	-35	-44	-42	-38	-34	-26		-23	-43	-45	-46	-43	-44	-40	-40
TRX6	2690	-30	-34	-40	-37	-34	-31	-23		-19	-37	-40	-41	-39	-40	-36	-36
TRX7	915	-35	-44	-52	-51	-47	-45	-39	-36		-53	-54	-54	-52	-52	-51	-49
TRX7	1910	-39	-36	-43	-41	-39	-37	-31	-29		-41	-44	-44	-42	-43	-40	-40
TRX7	2690	-31	-36	-39	-36	-35	-33	-27	-25		-36	-39	-40	-38	-39	-35	-36
TRX8	915	-34	-42	-46	-47	-54	-55	-56	-54	-49		-30	-35	-38	-43	-50	-52
TRX8	1910	-46	-35	-39	-39	-44	-44	-44	-43	-37		-23	-28	-31	-37	-40	-42
TRX8	2690	-32	-34	-36	-35	-39	-39	-40	-39	-34		-20	-25	-27	-34	-36	-38
TRX9	915	-34	-45	-44	-46	-54	-56	-56	-53	-49	-38		-28	-35	-41	-50	-52
TRX9	1910	-40	-37	-38	-38	-44	-44	-44	-43	-38	-30		-22	-28	-35	-40	-43
TRX9	2690	-32	-44	-34	-34	-39	-40	-40	-39	-34	-26		-19	-25	-32	-36	-38
TRX10	915	-34	-46	-42	-45	-54	-56	-55	-53	-49	-40	-33		-29	-37	-49	-52
TRX10	1910	-37	-35	-36	-37	-44	-44	-44	-43	-38	-32	-27		-23	-32	-40	-42
TRX10	2690	-31	-34	-33	-33	-39	-40	-39	-39	-34	-28	-24		-20	-29	-36	-38

Table 8. SKY13492-21: Isolation Matrix: Isolation “On” Arms to “Off” Arms (2 of 2)

“On” Arms	Freq (MHz)	Isolation (dB)															
		LTX	HTX	TRX1	TRX2	TRX3	TRX4	TRX5	TRX6	TRX7	TRX8	TRX9	TRX10	TRX11	TRX12	TRX13	TRX14
TRX11	915	-34	-47	-38	-42	-54	-55	-55	-53	-49	-43	-39	-34		-30	-48	-52
TRX11	1910	-35	-33	-32	-35	-44	-44	-44	-43	-38	-34	-32	-28		-24	-39	-42
TRX11	2690	-30	-30	-29	-32	-39	-39	-39	-38	-34	-30	-28	-25		-21	-36	-38
TRX12	915	-34	-48	-29	-35	-53	-55	-55	-54	-49	-52	-46	-42	-36		-40	-51
TRX12	1910	-35	-33	-23	-27	-43	-44	-44	-43	-38	-41	-39	-36	-29		-31	-41
TRX12	2690	-29	-30	-19	-24	-39	-39	-39	-38	-34	-36	-35	-33	-26		-27	-38
TRX13	915	-48	-72	-58	-54	-31	-37	-44	-49	-53	-65	-65	-64	-63	-61		-46
TRX13	1910	-47	-63	-55	-51	-28	-33	-40	-46	-50	-63	-62	-61	-60	-58		-38
TRX13	2690	-45	-54	-55	-53	-27	-31	-38	-44	-48	-60	-60	-59	-59	-57		-34
TRX14	915	-61	-61	-33	-17	-53	-57	-60	-63	-65	-59	-56	-51	-44	-39	-46	
TRX14	1910	-56	-47	-29	-13	-51	-54	-58	-61	-64	-57	-53	-48	-41	-36	-39	
TRX14	2690	-52	-44	-27	-10	-48	-52	-56	-60	-63	-56	-52	-47	-39	-34	-34	

Table 9. SKY13492-21 Isolation Matrix: Isolation “Ant” to “Off” Arms (1 of 2)
(V_{DD} = 2.85 V, T_{OP} = +25 °C, Characteristic Impedance [Z₀] = 50 Ω, Unless Otherwise Noted)

“On” Arms	Freq (MHz)	Isolation (dB)															
		LTX	HTX	TRX1	TRX2	TRX3	TRX4	TRX5	TRX6	TRX7	TRX8	TRX9	TRX10	TRX11	TRX12	TRX13	TRX14
LTX	915		-33	-48	-48	-40	-38	-40	-39	-34	-42	-44	-46	-47	-48	-43	-47
LTX	1910		-45	-54	-54	-45	-41	-35	-35	-32	-44	-46	-49	-51	-53	-48	-51
LTX	2690		-38	-45	-42	-43	-39	-34	-34	-32	-43	-44	-45	-44	-44	-45	-42
HTX	915	-40		-50	-49	-46	-45	-43	-42	-38	-42	-47	-49	-43	-46	-48	-47
HTX	1910	-24		-42	-40	-39	-38	-36	-35	-32	-32	-37	-38	-36	-39	-40	-39
HTX	2690	-21		-39	-36	-36	-34	-33	-32	-31	-29	-34	-35	-36	-39	-38	-36
TRX1	915	-38	-35		-36	-48	-45	-44	-44	-39	-46	-51	-54	-51	-44	-50	-40
TRX1	1910	-34	-31		-30	-41	-39	-38	-37	-33	-39	-42	-43	-39	-32	-42	-30
TRX1	2690	-28	-32		-25	-38	-36	-36	-35	-30	-35	-38	-39	-35	-28	-39	-25
TRX2	915	-38	-34	-43		-48	-46	-45	-44	-39	-46	-50	-53	-50	-45	-52	-42
TRX2	1910	-34	-30	-32		-41	-39	-39	-38	-33	-39	-42	-43	-39	-35	-43	-31
TRX2	2690	-29	-34	-28		-38	-36	-36	-35	-29	-35	-38	-40	-35	-31	-39	-26
TRX3	915	-36	-36	-49	-49		-35	-43	-48	-41	-45	-47	-47	-47	-47	-44	-52
TRX3	1910	-32	-32	-41	-38		-29	-36	-37	-32	-38	-41	-41	-40	-40	-31	-40
TRX3	2690	-27	-36	-38	-35		-24	-31	-32	-28	-35	-38	-38	-36	-37	-27	-37
TRX4	915	-36	-37	-49	-49	-45		-33	-43	-41	-45	-47	-47	-47	-48	-46	-51
TRX4	1910	-31	-33	-41	-39	-33		-28	-35	-32	-38	-41	-41	-40	-41	-34	-40
TRX4	2690	-27	-37	-38	-36	-28		-24	-30	-28	-35	-38	-38	-36	-37	-30	-36
TRX5	915	-38	-37	-50	-49	-50	-42		-35	-40	-45	-47	-48	-48	-49	-52	-51
TRX5	1910	-32	-33	-42	-40	-39	-33		-29	-30	-38	-41	-41	-40	-41	-41	-40
TRX5	2690	-27	-40	-39	-36	-35	-29		-24	-26	-35	-37	-38	-37	-38	-36	-36

Table 9. SKY13492-21 Isolation Matrix: Isolation "Ant" to "Off" Arms (2 of 2)
 (V_{DD} = 2.85 V, T_{OP} = +25 °C, Characteristic Impedance [Z₀] = 50 Ω, Unless Otherwise Noted)

"On" Arms	Freq (MHz)	Isolation (dB)															
		LTX	HTX	TRX1	TRX2	TRX3	TRX4	TRX5	TRX6	TRX7	TRX8	TRX9	TRX10	TRX11	TRX12	TRX13	TRX14
TRX6	915	-40	-38	-50	-49	-52	-50	-44		-37	-46	-48	-48	-48	-50	-51	-51
TRX6	1910	-34	-34	-42	-40	-41	-39	-32		-28	-39	-41	-41	-41	-42	-41	-40
TRX6	2690	-28	-43	-39	-36	-37	-34	-28		-22	-35	-37	-38	-37	-38	-37	-36
TRX7	915	-43	-39	-51	-50	-51	-51	-45	-42		-47	-49	-49	-49	-50	-51	-50
TRX7	1910	-37	-34	-42	-40	-41	-39	-34	-31		-39	-41	-42	-41	-42	-41	-40
TRX7	2690	-29	-45	-38	-36	-36	-35	-30	-27		-34	-37	-38	-37	-38	-36	-35
TRX8	915	-40	-33	-57	-53	-47	-45	-43	-43	-39		-36	-45	-49	-54	-49	-50
TRX8	1910	-37	-28	-45	-42	-40	-38	-37	-36	-32		-31	-37	-37	-44	-41	-39
TRX8	2690	-28	-27	-40	-37	-36	-35	-34	-33	-30		-26	-31	-31	-39	-37	-35
TRX9	915	-39	-35	-55	-53	-47	-45	-43	-43	-39	-41		-34	-45	-49	-49	-50
TRX9	1910	-36	-32	-45	-42	-40	-38	-37	-36	-32	-31		-29	-36	-42	-41	-39
TRX9	2690	-29	-37	-39	-37	-37	-35	-34	-34	-30	-26		-24	-31	-37	-37	-35
TRX10	915	-39	-36	-50	-53	-47	-45	-43	-43	-39	-43	-45		-35	-43	-49	-50
TRX10	1910	-35	-32	-43	-42	-40	-38	-37	-36	-32	-33	-33		-30	-38	-41	-39
TRX10	2690	-29	-41	-38	-38	-37	-35	-34	-34	-30	-29	-29		-26	-34	-38	-34
TRX11	915	-38	-35	-43	-50	-47	-45	-43	-43	-39	-42	-47	-46		-34	-49	-49
TRX11	1910	-35	-32	-38	-42	-40	-38	-37	-37	-32	-33	-36	-35		-29	-41	-39
TRX11	2690	-29	-36	-34	-37	-37	-35	-34	-34	-30	-29	-32	-30		-25	-38	-34
TRX12	915	-38	-35	-35	-45	-47	-45	-44	-43	-39	-47	-53	-51	-44		-49	-41
TRX12	1910	-34	-32	-30	-34	-40	-38	-38	-37	-33	-39	-42	-42	-35		-42	-31
TRX12	2690	-28	-32	-25	-29	-37	-36	-35	-35	-30	-35	-38	-37	-31		-38	-26
TRX13	915	-37	-33	-46	-44	-50	-46	-45	-44	-39	-46	-49	-51	-49	-44		-49
TRX13	1910	-34	-29	-36	-33	-42	-39	-39	-38	-33	-39	-41	-42	-39	-35		-42
TRX13	2690	-29	-33	-31	-28	-38	-36	-35	-34	-29	-35	-38	-39	-35	-30		-38
TRX14	915	-37	-36	-49	-49	-35	-45	-49	-48	-40	-45	-47	-47	-46	-47	-41	
TRX14	1910	-33	-32	-40	-37	-29	-35	-39	-38	-32	-38	-41	-41	-39	-40	-31	
TRX14	2690	-28	-35	-37	-34	-24	-29	-34	-33	-28	-35	-38	-38	-36	-37	-26	

Table 10. SKY13492-21: Insertion loss and Return loss Matrix (1 of 2)
(V_{DD} = 2.85 V, T_{OP}=+25 °C, Characteristic Impedance [Z₀]=50 Ω, Unless Otherwise Noted)

ON_Throw	freq_MHz	IL	RL_Pole	RL_Throw
TXLB	915	-1.4	-13.7	-15.2
TXLB	1910	-23.6	-1.5	-0.2
TXLB	2690	-25.2	-2.2	-0.6
TXHB	915	-0.8	-30.3	-19.1
TXHB	1910	-1.3	-16.7	-17.0
TXHB	2690	-9.2	-3.3	-1.6
TRX1	915	-0.6	-24.3	-22.2
TRX1	1910	-0.7	-20.7	-23.4
TRX1	2690	-0.9	-22.3	-16.8
TRX2	915	-0.6	-22.3	-20.7
TRX2	1910	-0.7	-23.3	-26.9
TRX2	2690	-0.9	-20.5	-16.4
TRX3	915	-0.6	-22.2	-21.1
TRX3	1910	-0.7	-22.6	-24.8
TRX3	2690	-0.9	-22.4	-17.1
TRX4	915	-0.6	-23.3	-22.7
TRX4	1910	-0.7	-20.3	-22.4
TRX4	2690	-0.9	-26.7	-18.7
TRX5	915	-0.6	-26.7	-26.1
TRX5	1910	-0.7	-17.8	-20.1
TRX5	2690	-0.8	-33.9	-22.2
TRX6	915	-0.6	-26.8	-27.5
TRX6	1910	-0.7	-16.0	-17.7
TRX6	2690	-0.9	-22.6	-22.4
TRX7	915	-0.6	-27.3	-26.9
TRX7	1910	-0.8	-13.9	-15.3
TRX7	2690	-1.0	-15.6	-17.0
TRX8	915	-0.6	-27.1	-24.0
TRX8	1910	-0.7	-17.5	-20.0
TRX8	2690	-0.9	-32.8	-22.4
TRX9	915	-0.6	-27.3	-24.3
TRX9	1910	-0.7	-17.3	-19.2
TRX9	2690	-0.9	-30.1	-21.3
TRX10	915	-0.6	-26.8	-24.6
TRX10	1910	-0.7	-17.6	-19.8
TRX10	2690	-0.9	-26.0	-19.8

Table 10. SKY13492-21: Insertion loss and Return loss Matrix (2 of 2)
(V_{DD} = 2.85 V, T_{OP}=+25 °C, Characteristic Impedance [Z₀]=50 Ω, Unless Otherwise Noted)

ON_Throw	freq_MHz	IL	RL_Pole	RL_Throw
TRX11	915	-0.6	-26.7	-24.5
TRX11	1910	-0.7	-18.5	-21.1
TRX11	2690	-0.9	-28.1	-20.4
TRX12	915	-0.6	-24.9	-23.2
TRX12	1910	-0.7	-19.8	-22.6
TRX12	2690	-0.9	-24.4	-18.2
TRX13	915	-0.6	-20.7	-21.0
TRX13	1910	-0.7	-24.4	-26.3
TRX13	2690	-0.9	-19.9	-16.7
TRX14	915	-0.6	-20.5	-20.1
TRX14	1910	-0.7	-24.9	-31.5
TRX14	2690	-0.9	-20.0	-17.2

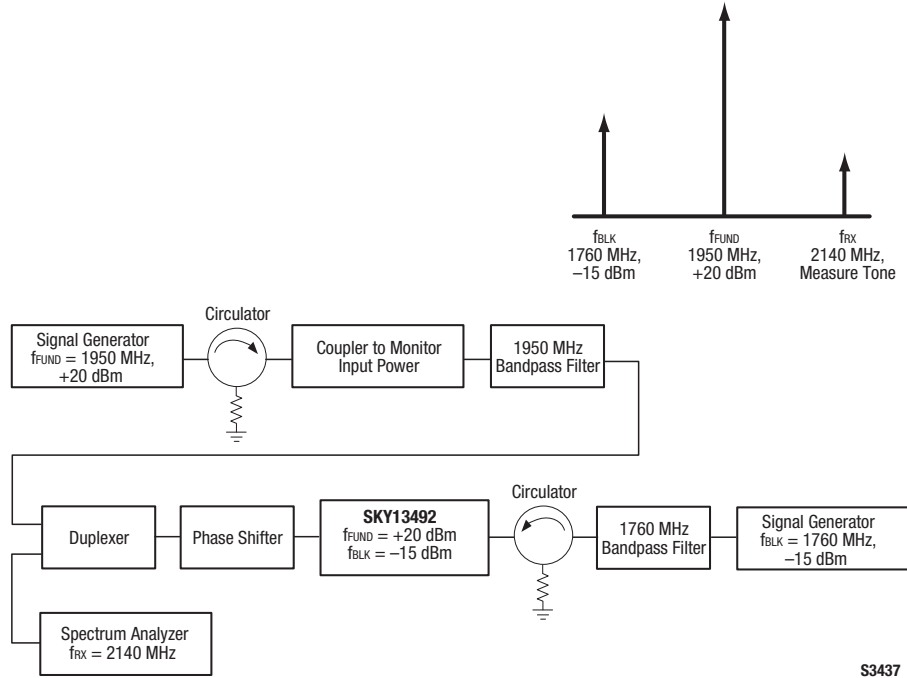

Figure 4. Third Order Intermodulation Test Setup

Table 11. Command Sequence Bit Definitions

Type	SSC	C11–C8	C7	C6–C5	C4	C3–C0	Parity Bits	BPC	Extended Operation					
									DA7(1)–DA0(1)	Parity Bits	BPC	DA7(n)–DA0(n)	Parity Bits	BPC
Reg0 Write	Y	SA[3:0]	1	Data[6:5]	Data[4]	Data[3:0]	Y	Y	–	–	–	–	–	–
Reg Write	Y	SA[3:0]	0	10	Addr[4]	Addr[3:0]	Y	–	Data[7:0]	–	–	–	Y	Y
Reg Read	Y	SA[3:0]	0	11	Addr[4]	Addr[3:0]	Y	Y	Data[7:0]	–	–	–	Y	Y

Legend:

SSC = Sequence start command DA = Data/address frame bits BC = Byte count (# of consecutive addresses)
 C = Command frame bits BPC = Bus park cycle

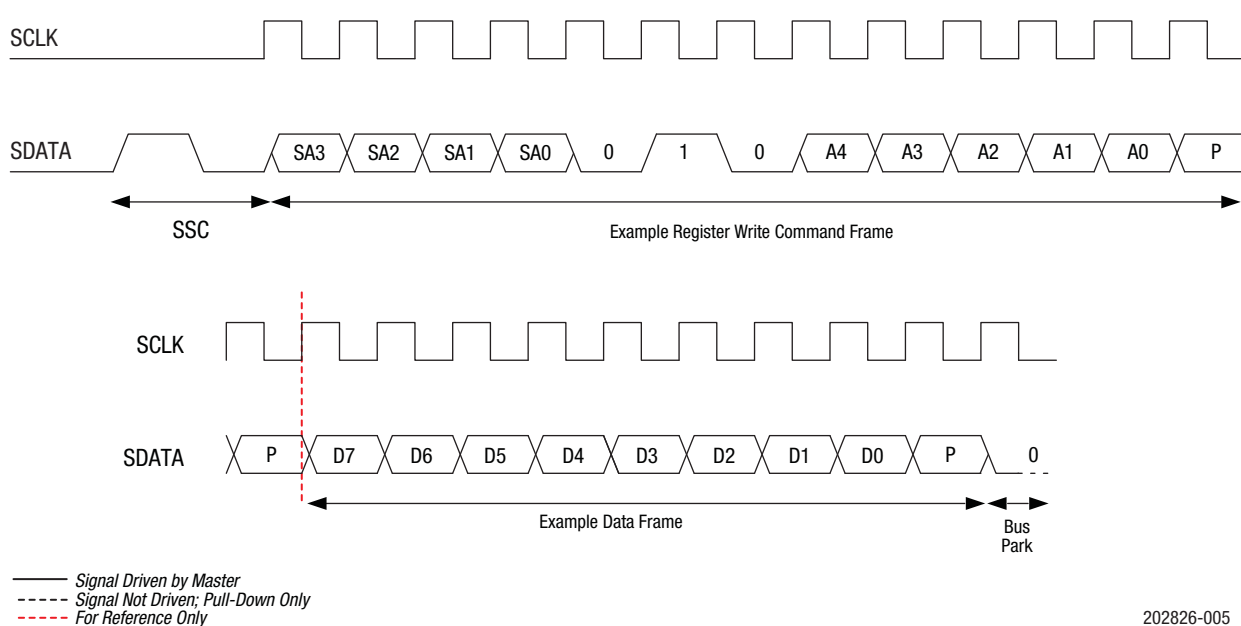

Figure 5. Register Write Command Timing Diagram

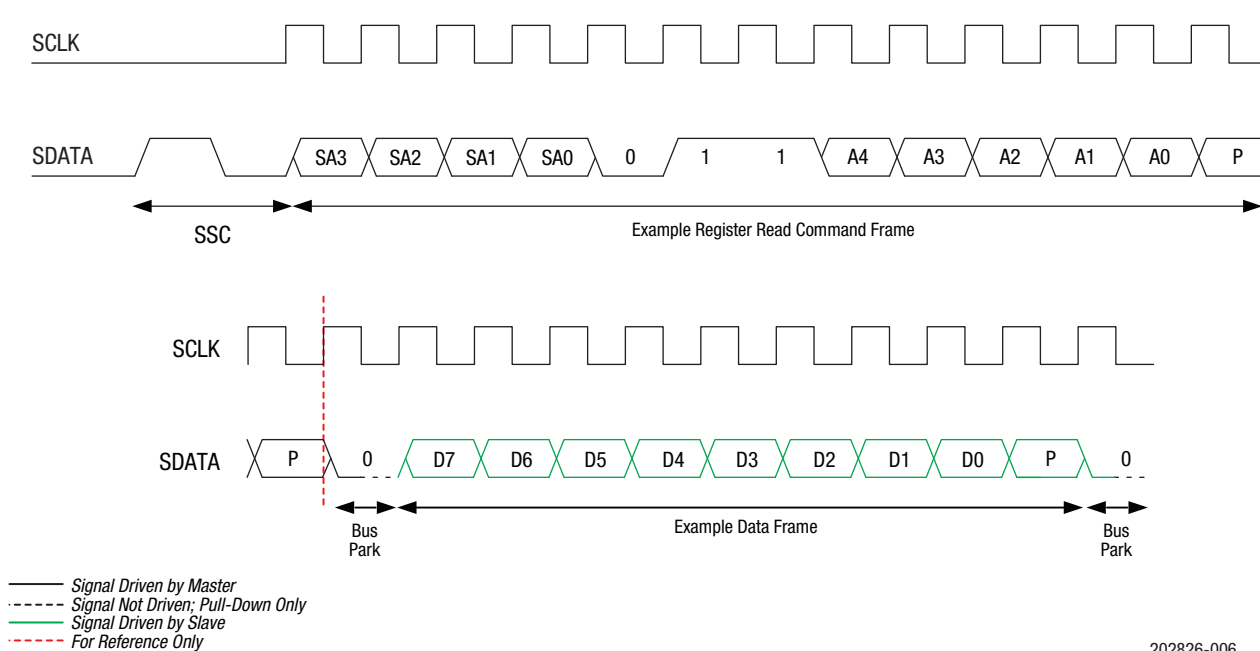

Figure 6. Register Read Command Timing Diagram

Table 12. Register_0 Truth Table

Antenna Path	Register_0 Bits							
	Bit[7]	Bit[6]	Bit[5]	Bit[4]	Bit[3]	Bit[2]	Bit[1]	Bit[0]
Sleep mode (standby)	X	0	0	0	0	0	0	0
2G transmit low band	X	0	0	0	1	0	1	0
2G transmit high band	X	0	0	0	1	0	0	0
TRX1	X	0	0	0	0	1	0	0
TRX2	X	0	0	0	0	1	0	1
TRX3	X	0	0	0	0	1	1	0
TRX4	X	0	0	0	0	1	1	1
TRX5	X	0	0	0	1	0	0	1
TRX6	X	0	0	0	1	0	1	1
TRX7	X	0	0	0	1	1	0	0
TRX8	X	0	0	0	0	0	0	1
TRX9	X	0	0	0	0	0	1	0
TRX10	X	0	0	0	0	0	1	1
TRX11	X	0	0	0	1	1	0	1
TRX12	X	0	0	0	1	1	1	0
TRX13	X	0	0	1	0	0	0	0
TRX14	X	0	0	1	0	0	0	1
Isolation mode (warm-up)	X	1	1	1	1	1	1	1

Table 13. Register Description and Programming (1 of 2)

Register		Parameter	Description	Default (Binary)
Name	Address (Hex)			
Register_0	0000	MODE_CTRL	Bits[7:0]: Switch control. See Table 8 for logic	–
RFFE_STATUS	001A	SOFTWARE RESET	Bit[7]: Resets all data to default values except for USID, GSID, or the contents of the PM_TRIG Register. 0 = Normal operation 1 = Software reset	0
		COMMAND_FRAME_PARITY_ERR	Bit[6]: Command sequence received with parity error – discard command.	0
		COMMAND_LENGTH_ERR	Bit[5]: Command length error.	0
		ADDRESS_FRAME_PARITY_ERR	Bit[4]: Address frame parity error = 1.	0
		DATA_FRAME_PARITY_ERR	Bit[3]: Data frame with parity error.	0
		READ_UNUSED_REG	Bit[2]: Read command to an invalid address.	0
		WRITE_UNUSED_REG	Bit[1]: Write command to an invalid address.	0
		BID_GID_ERR	Bit[0]: Read command with a BROADCAST_ID (refer to the <i>MIPI Alliance Specification</i>) or GSID.	0
GROUP_SID	001B	Reserved	Bits[7:4]: Reserved	0000
		GSID	Bits[3:0]: Group slave ID	0000

Table 13. Register Description and Programming (2 of 2)

Register		Parameter	Description	Default (Binary)
Name	Address (Hex)			
PM_TRIG ¹	001C	PWR_MODE	Bits[7:6]: 00 = Normal operation (active) 01 = Default settings (startup) 10 = Low power (low power) 11 = Reserved	01
		Trigger_Mask_2	Bit[5]: If this bit is set, trigger 2 is disabled. When all triggers are disabled, if writing to a register that is associated with trigger 2, the data goes directly to the destination register.	0
		Trigger_Mask_1	Bit[4]: If this bit is set, trigger 1 is disabled. When all triggers are disabled, if writing to a register that is associated with trigger 1, the data goes directly to the destination register.	0
		Trigger_Mask_0	Bit[3]: If this bit is set, trigger 0 is disabled. When all triggers are disabled, if writing to a register that is associated with trigger 0, the data goes directly to the destination register.	0
		Trigger_2	Bit[2]: If this bit is set, data is loaded into the trigger 2 registers.	0
		Trigger_1	Bit[1]: If this bit is set, data is loaded into the trigger 1 registers (unsupported).	0
		Trigger_0	Bit[0]: If this bit is set, data is loaded into the trigger 0 registers (unsupported).	0
PRODUCT_ID	001D	PRODUCT_ID	Bits[7:0]: This is a read-only register. However, during the programming of the Unique Slave Identifier (USID), a write command sequence is performed on this register but the value is not changed.	01011101
MANUFACTURER_ID	001E	MANUFACTURER_ID	Bits[7:0]: Read-only register	10100101
MAN_USID	001F	Reserved	Bits[7:6]: Reserved	00
		MANUFACTURER_ID	Bits[5:4]: Read-only register	01
		USID	Bits[3:0]: Programmable USID. A write to these bits programs the USID.	1011

¹ Unlike the complete independence between triggers 0, 1, and 2, and also between the associated trigger masks 0, 1, and 2, respectively (as described in the MIPI RFFE Specification), when pin 7 is grounded, this device uses additional interactions between the provided trigger functions.

The delayed application of updated data to all triggerable registers in this device may be accomplished using any of the three triggers (0, 1, or 2), provided that the particular trigger used is not currently masked off. If multiple triggers are enabled, any or all of those are sufficient to cause the data to be transferred from shadow registers to destination registers for all triggerable registers in the device.

It is also necessary to disable all three triggers (i.e., set all three trigger masks) to ensure that data written to any triggerable register will immediately be written to the destination register at the conclusion of the RFFE command sequence where the data is written.

Evaluation Board Description

The SKY13492-21 Evaluation Board is used to test the performance of the SKY13492-21 SP16T Switch. An Evaluation Board schematic diagram is provided in Figure 7. A recommended ESD protection circuit diagram is provided in Figure 8. An assembly drawing for the Evaluation Board is shown in Figure 9.

Package Dimensions

The PCB layout footprint for the SKY13492-21 is provided in Figure 10. Typical part markings are shown in Figure 11. Package dimensions are shown in Figure 12, and tape and reel dimensions are provided in Figure 13.

Package and Handling Information

Since the device package is sensitive to moisture absorption, it is baked and vacuum packed before shipping. Instructions on the shipping container label regarding exposure to moisture after the container seal is broken must be followed. Otherwise, problems related to moisture absorption may occur when the part is subjected to high temperature during solder assembly.

The SKY13492-21 is rated to Moisture Sensitivity Level 3 (MSL3) at 260 °C. It can be used for lead or lead-free soldering. For additional information, refer to the Skyworks Application Note, *PCB Design and SMT Assembly/Rework Guidelines for MCM-L Packages*, document number 101752.

Care must be taken when attaching this product, whether it is done manually or in a production solder reflow environment. Production quantities of this product are shipped in a standard tape and reel format.

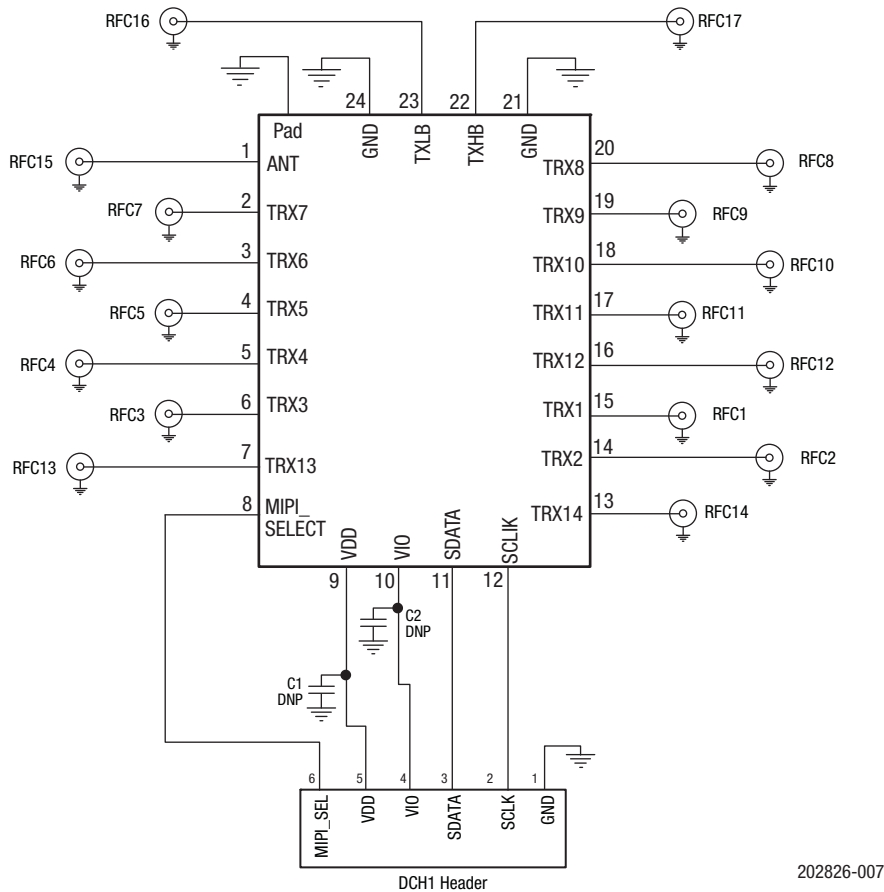
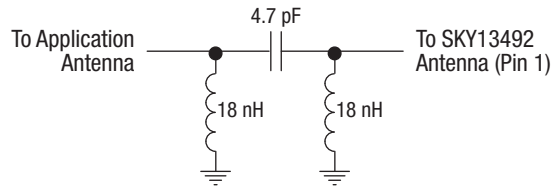
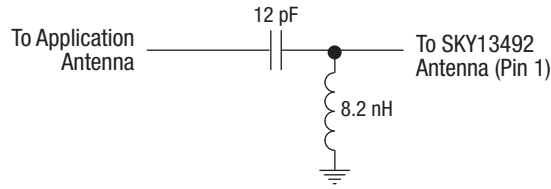

Figure 7. SKY13492-21 Evaluation Board Schematic



ESD Circuit 1



ESD Circuit 2

202826-008

Figure 8. SKY13492-21 Recommended ESD Protection Circuits

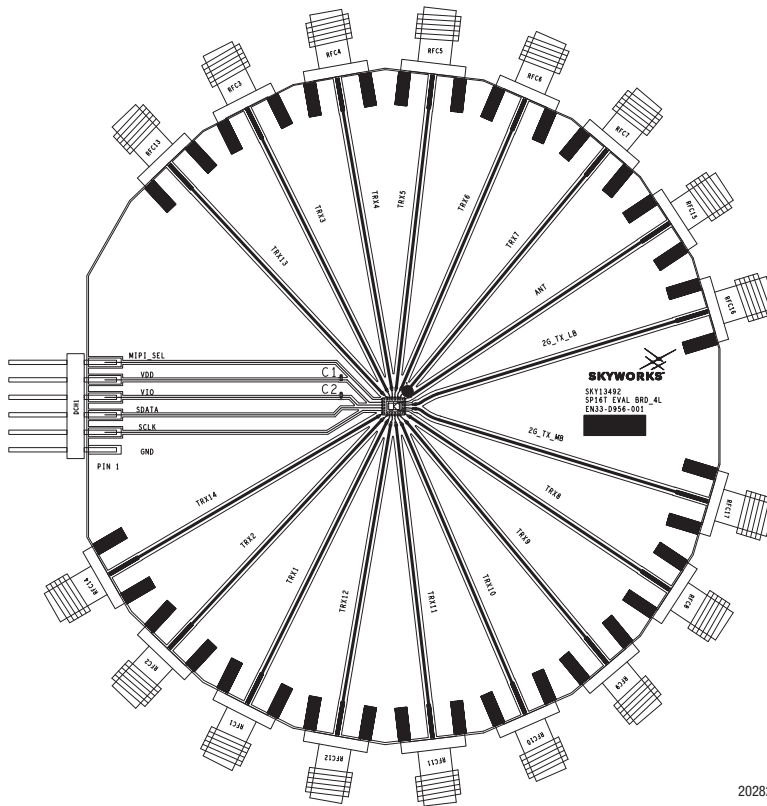
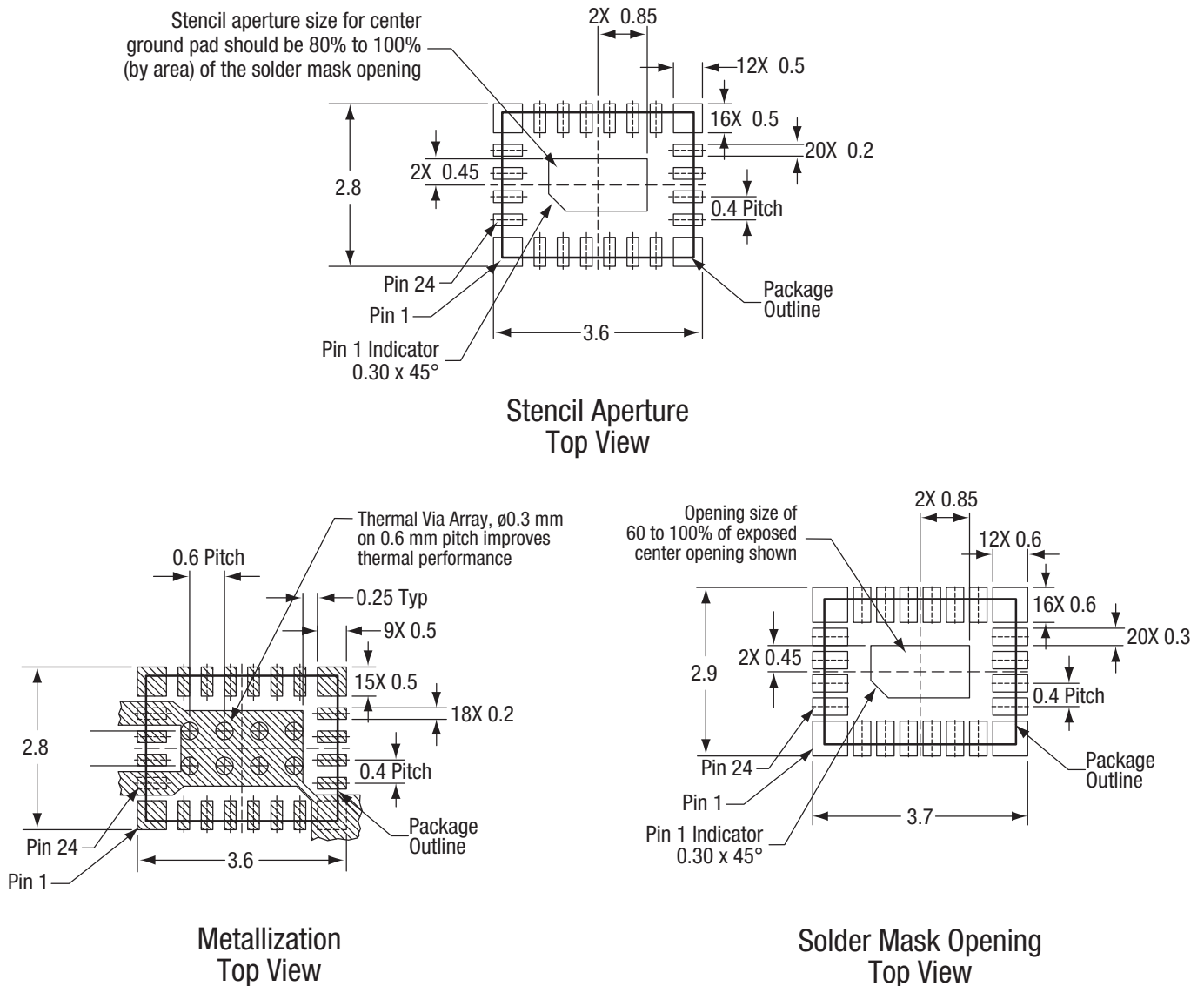

Figure 9. SKY13492-21 Evaluation Board Assembly Diagram



Notes:

1. All dimensions are in millimeters.
2. Thermal vias should be resin filled and capped according to IPC-4761, Type VII vias. Recommended Cu thickness is 30 to 35 μm .

202826-010

Figure 10. SKY13492-21 PCB Layout Footprint (Top View)

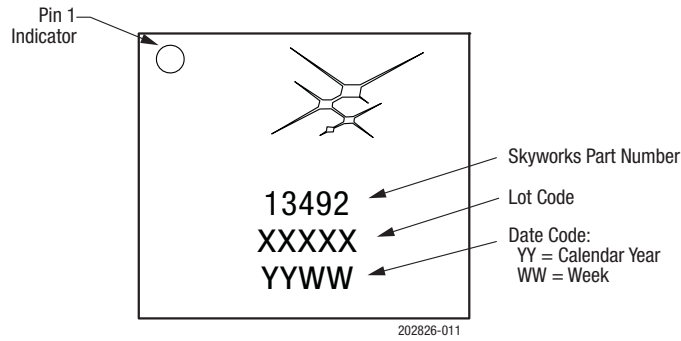
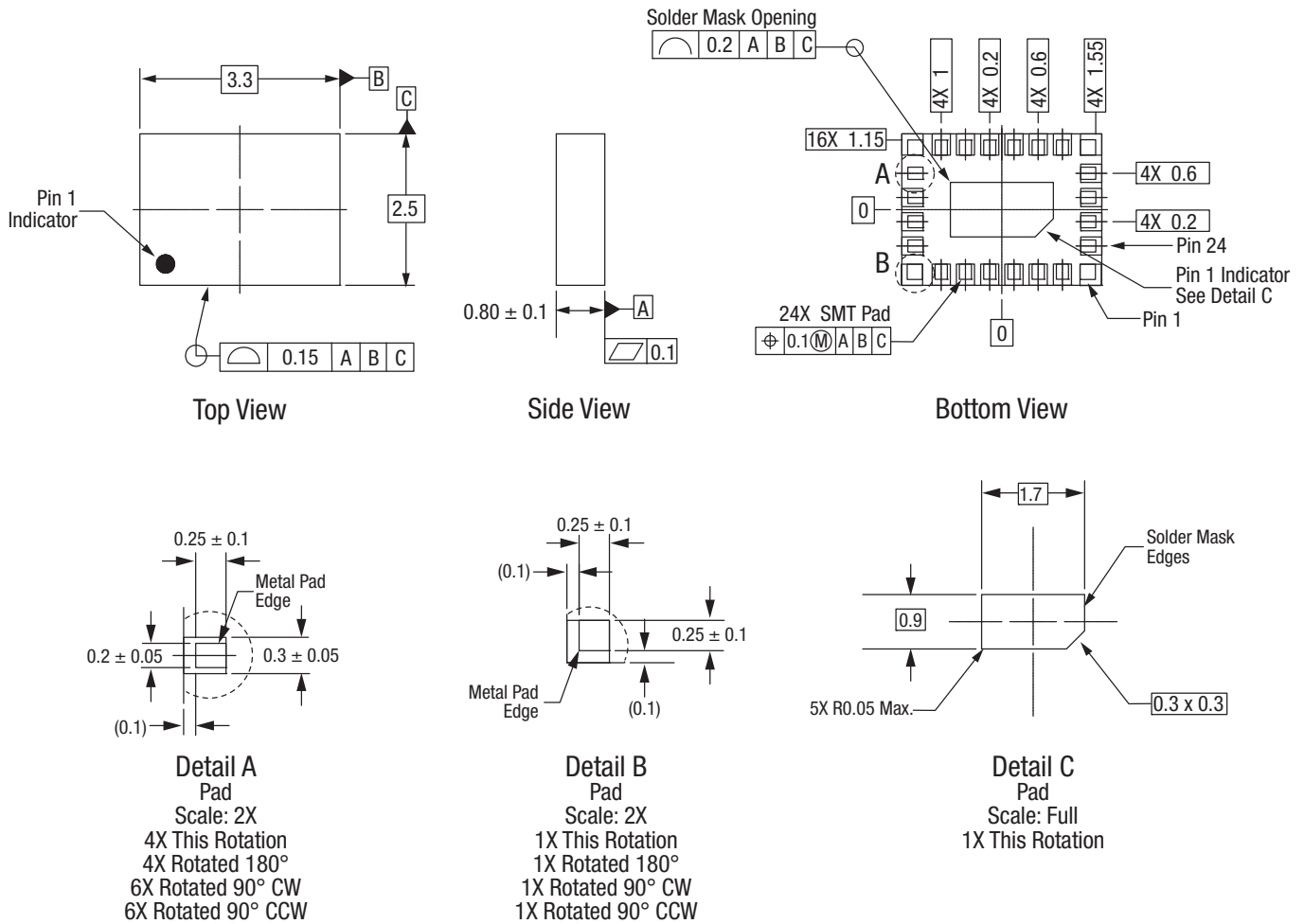

Figure 11. Typical Part Markings (Top View)



Notes:

1. All measurements are in millimeters.
2. Dimensions and tolerances according to ASME Y14.5M-1994.

202826-012

Figure 12. SKY13492-21 Package Dimensions

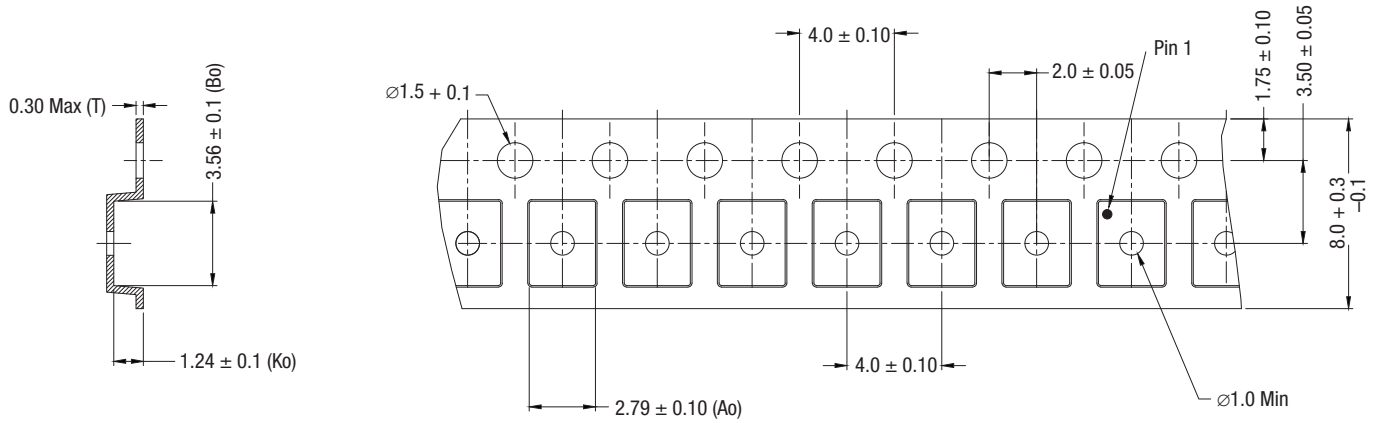

Notes:

1. Carrier tape must meet all requirements of Skyworks GP01-D233 procurement spec for tape and reel shipping.
2. Carrier tape: black conductive polycarbonate or polystyrene.
3. Cover tape material: transparent conductive.
4. ESD-surface resistivity shall be $\leq 1 \times 10^{10} \Omega/\text{square}$ per EIA, JEDEC TNR Specification.
5. 10-sprocket hole pitch cumulative tolerance: ± 0.20 mm.
6. All dimensions are in millimeters.

User Feed
Direction →

202826-013

Figure 13. SKY13492-21 Tape and Reel Dimensions

Ordering Information

Model Name	Manufacturing Part Number	Evaluation Board Part Number
SKY13492-21: 0.7 to 2.7 GHz SP16T Antenna Switch with MIPI Interface	SKY13492-21	SKY13492-21-EVB

Copyright © 2013-2016 Skyworks Solutions, Inc. All Rights Reserved.

Information in this document is provided in connection with Skyworks Solutions, Inc. (“Skyworks”) products or services. These materials, including the information contained herein, are provided by Skyworks as a service to its customers and may be used for informational purposes only by the customer. Skyworks assumes no responsibility for errors or omissions in these materials or the information contained herein. Skyworks may change its documentation, products, services, specifications or product descriptions at any time, without notice. Skyworks makes no commitment to update the materials or information and shall have no responsibility whatsoever for conflicts, incompatibilities, or other difficulties arising from any future changes.

No license, whether express, implied, by estoppel or otherwise, is granted to any intellectual property rights by this document. Skyworks assumes no liability for any materials, products or information provided hereunder, including the sale, distribution, reproduction or use of Skyworks products, information or materials, except as may be provided in Skyworks Terms and Conditions of Sale.

THE MATERIALS, PRODUCTS AND INFORMATION ARE PROVIDED “AS IS” WITHOUT WARRANTY OF ANY KIND, WHETHER EXPRESS, IMPLIED, STATUTORY, OR OTHERWISE, INCLUDING FITNESS FOR A PARTICULAR PURPOSE OR USE, MERCHANTABILITY, PERFORMANCE, QUALITY OR NON-INFRINGEMENT OF ANY INTELLECTUAL PROPERTY RIGHT; ALL SUCH WARRANTIES ARE HEREBY EXPRESSLY DISCLAIMED. SKYWORKS DOES NOT WARRANT THE ACCURACY OR COMPLETENESS OF THE INFORMATION, TEXT, GRAPHICS OR OTHER ITEMS CONTAINED WITHIN THESE MATERIALS. SKYWORKS SHALL NOT BE LIABLE FOR ANY DAMAGES, INCLUDING BUT NOT LIMITED TO ANY SPECIAL, INDIRECT, INCIDENTAL, STATUTORY, OR CONSEQUENTIAL DAMAGES, INCLUDING WITHOUT LIMITATION, LOST REVENUES OR LOST PROFITS THAT MAY RESULT FROM THE USE OF THE MATERIALS OR INFORMATION, WHETHER OR NOT THE RECIPIENT OF MATERIALS HAS BEEN ADVISED OF THE POSSIBILITY OF SUCH DAMAGE.

Skyworks products are not intended for use in medical, lifesaving or life-sustaining applications, or other equipment in which the failure of the Skyworks products could lead to personal injury, death, physical or environmental damage. Skyworks customers using or selling Skyworks products for use in such applications do so at their own risk and agree to fully indemnify Skyworks for any damages resulting from such improper use or sale.

Customers are responsible for their products and applications using Skyworks products, which may deviate from published specifications as a result of design defects, errors, or operation of products outside of published parameters or design specifications. Customers should include design and operating safeguards to minimize these and other risks. Skyworks assumes no liability for applications assistance, customer product design, or damage to any equipment resulting from the use of Skyworks products outside of stated published specifications or parameters.

Skyworks and the Skyworks symbol are trademarks or registered trademarks of Skyworks Solutions, Inc., in the United States and other countries. Third-party brands and names are for identification purposes only, and are the property of their respective owners. Additional information, including relevant terms and conditions, posted at www.skyworksinc.com, are incorporated by reference.



**Стандарт
Электрон
Связь**

Мы молодая и активно развивающаяся компания в области поставок электронных компонентов. Мы поставляем электронные компоненты отечественного и импортного производства напрямую от производителей и с крупнейших складов мира.

Благодаря сотрудничеству с мировыми поставщиками мы осуществляем комплексные и плановые поставки широчайшего спектра электронных компонентов.

Собственная эффективная логистика и склад в обеспечивает надежную поставку продукции в точно указанные сроки по всей России.

Мы осуществляем техническую поддержку нашим клиентам и предпродажную проверку качества продукции. На все поставляемые продукты мы предоставляем гарантию .

Осуществляем поставки продукции под контролем ВП МО РФ на предприятия военно-промышленного комплекса России , а также работаем в рамках 275 ФЗ с открытием отдельных счетов в уполномоченном банке. Система менеджмента качества компании соответствует требованиям ГОСТ ISO 9001.

Минимальные сроки поставки, гибкие цены, неограниченный ассортимент и индивидуальный подход к клиентам являются основой для выстраивания долгосрочного и эффективного сотрудничества с предприятиями радиоэлектронной промышленности, предприятиями ВПК и научно-исследовательскими институтами России.

С нами вы становитесь еще успешнее!

Наши контакты:

Телефон: +7 812 627 14 35

Электронная почта: sales@st-electron.ru

Адрес: 198099, Санкт-Петербург,
Промышленная ул, дом № 19, литера Н,
помещение 100-Н Офис 331