

PXAC243502FV

High Power RF LDMOS Field Effect Transistor 350 W, 28 V, 2300 – 2400 MHz

Description

The PXAC243502FV LDMOS FET is a 350-watt LDMOS FET designed for use in power amplifier applications in the 2300 MHz to 2400 MHz frequency band. Features include an asymmetric design with high gain and a thermally-enhanced package with earless flange. Manufactured with Wolfspeed's advanced LDMOS process, this device provides excellent thermal performance and superior reliability.

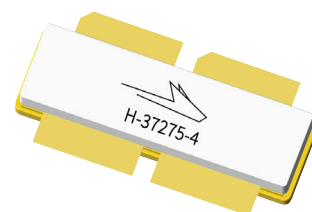

PXAC243502FV
Package H-37275-4

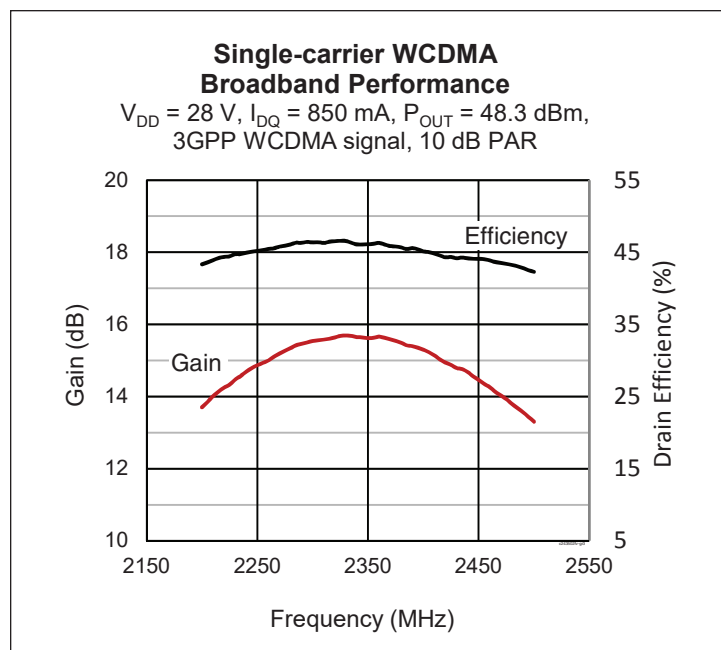

Features

- Asymmetric design
 - Main: 150 W P_{1dB}
 - Peak: 200 W P_{1dB}
- Broadband internal matching
- CW performance at 2350 MHz, 28 V
 - Output power = 250 W P_{1dB}
 - Efficiency = 46%
 - Gain = 16 dB
- Integrated ESD protection
- Human Body Model Class 2 (per ANSI/ESDA/ JEDEC JS-001)
- Low thermal resistance
- Pb-free and RoHS-compliant

RF Characteristics

Single-carrier WCDMA Specifications (tested in Wolfspeed production test fixture in Doherty configuration)

$V_{DD} = 28\text{ V}$, $V_{GS(peak)} = 1.0\text{ V}$, $I_{DQ} = 850\text{ mA}$, $P_{OUT} = 68\text{ W avg}$, $f = 2400\text{ MHz}$
3GPP WCDMA signal, 3.84 MHz channel bandwidth, 10 dB peak/average @ 0.01% CCDF

Characteristic	Symbol	Min	Typ	Max	Unit
Gain	G_{ps}	14.0	15.0	—	dB
Drain Efficiency	η_D	42	45	—	%
Adjacent Channel Power Ratio	ACPR	—	-32	-26	dBc

All published data at $T_{CASE} = 25^\circ\text{C}$ unless otherwise indicated

ESD: Electrostatic discharge sensitive device—observe handling precautions!

DC Characteristics

Characteristic	Conditions	Symbol	Min	Typ	Max	Unit
Drain-Source Breakdown Voltage	$V_{GS} = 0\text{ V}$, $I_{DS} = 10\text{ mA}$	$V_{(BR)DSS}$	65	—	—	V
Drain Leakage Current	$V_{DS} = 28\text{ V}$, $V_{GS} = 0\text{ V}$	I_{DSS}	—	—	1	μA
	$V_{DS} = 63\text{ V}$, $V_{GS} = 0\text{ V}$	I_{DSS}	—	—	10	μA
Gate Leakage Current	$V_{GS} = 10\text{ V}$, $V_{DS} = 0\text{ V}$	I_{GSS}	—	—	1	μA
On-State Resistance	main $V_{GS} = 10\text{ V}$, $V_{DS} = 0.1\text{ V}$	$R_{DS(on)}$	—	0.088	—	Ω
	peak $V_{GS} = 10\text{ V}$, $V_{DS} = 0.1\text{ V}$	$R_{DS(on)}$	—	0.088	—	Ω
Operating Gate Voltage	main $V_{DS} = 28\text{ V}$, $I_{DQ} = 850\text{ mA}$	V_{GS}	2.3	2.6	3.0	V
	peak $V_{DS} = 28\text{ V}$, $I_{DQ} = 0\text{ mA}$	V_{GS}	0.8	1.2	1.6	V

Maximum Ratings

Parameter	Symbol	Value	Unit
Drain-Source Voltage	V_{DSS}	65	V
Gate-Source Voltage	V_{GS}	-6 to +10	V
Operating Voltage	V_{DD}	0 to +32	V
Junction Temperature	T_J	225	$^{\circ}\text{C}$
Storage Temperature Range	T_{STG}	-65 to +150	$^{\circ}\text{C}$
Thermal Resistance ($T_{CASE} = 70^{\circ}\text{C}$, 250 W CW)	$R_{\theta JC}$	0.22	$^{\circ}\text{C/W}$

Ordering Information

Type and Version	Order Code	Package and Description	Shipping
PXAC243502FV V1 R0	PXAC243502FV-V1-R0	H-37275-4	Tape & Reel, 50 pcs
PXAC243502FV V1 R250	PXAC243502FV-V1-R250	H-37275-4	Tape & Reel, 250 pcs

Typical RF Performance (data taken in production test fixture)

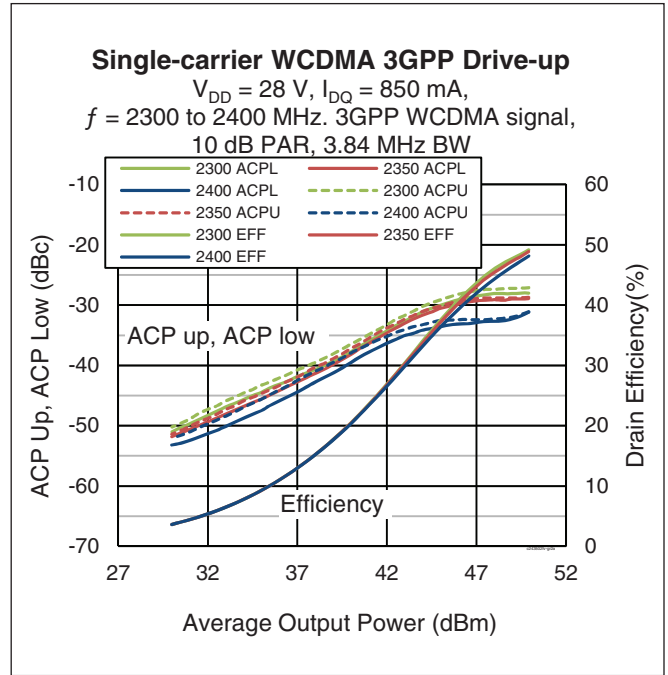
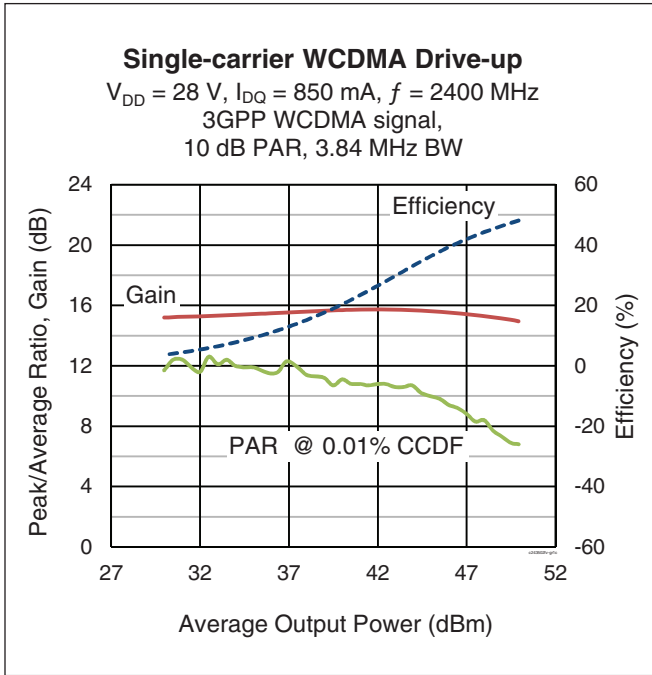
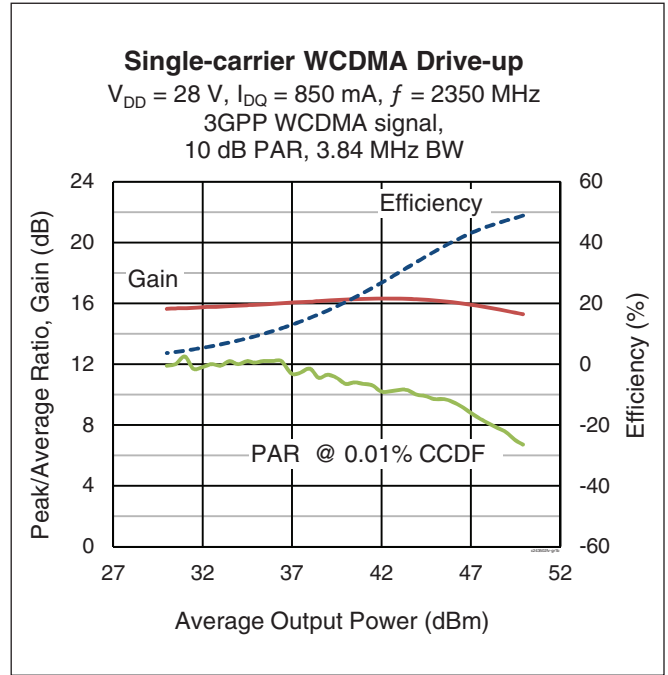
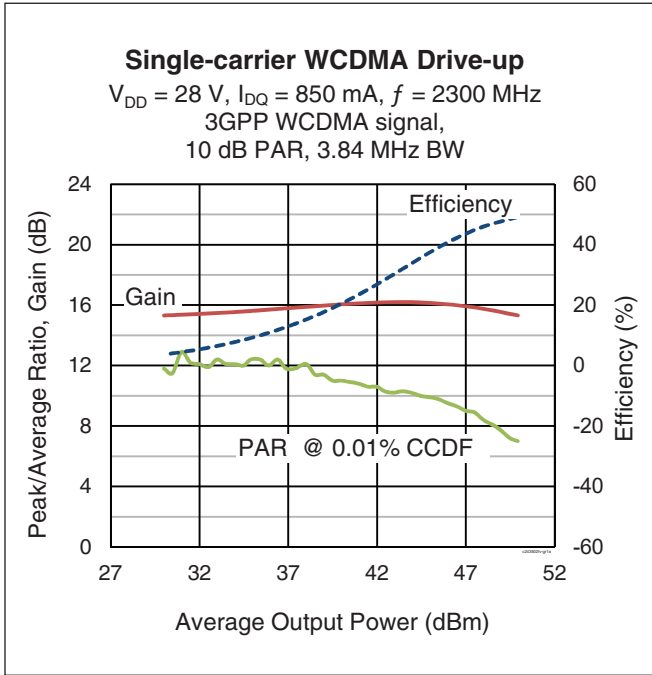



Typical RF Performance (cont.)

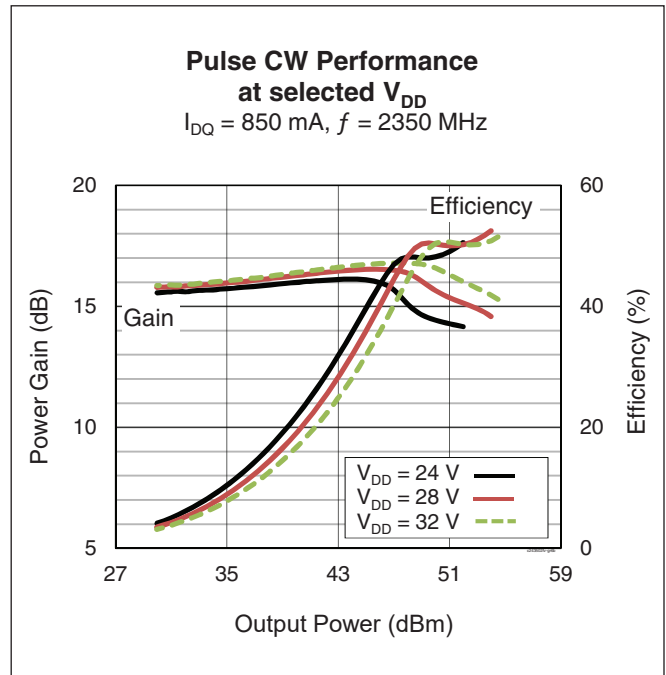
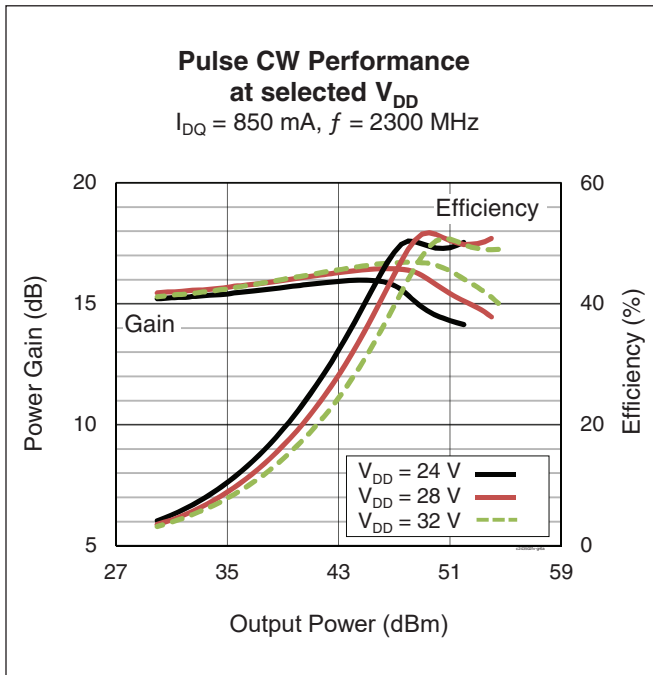
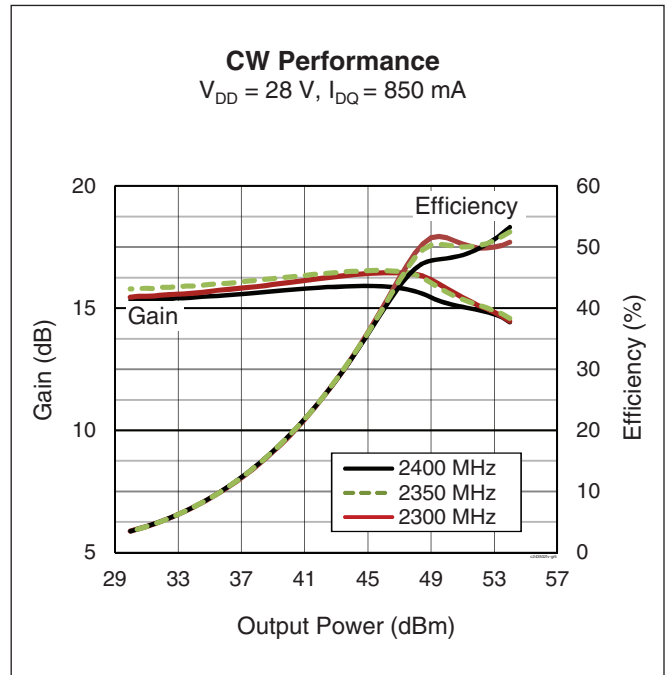
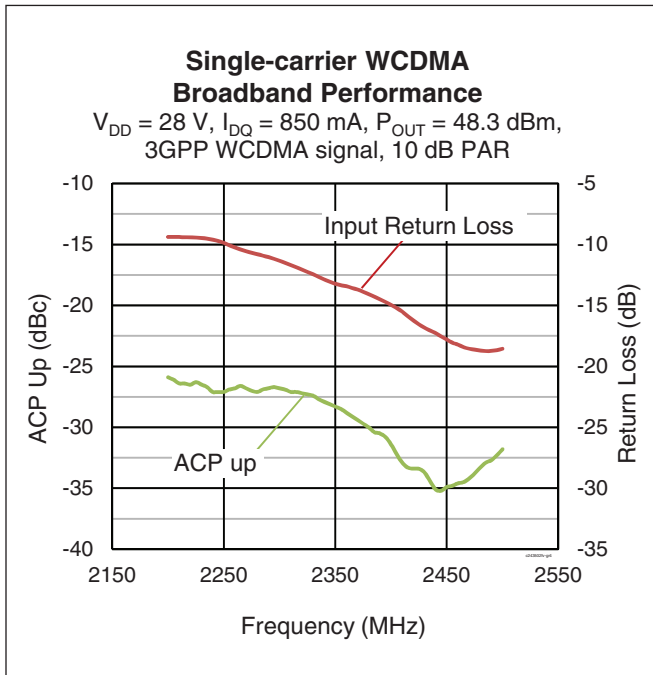

Typical RF Performance (cont.)

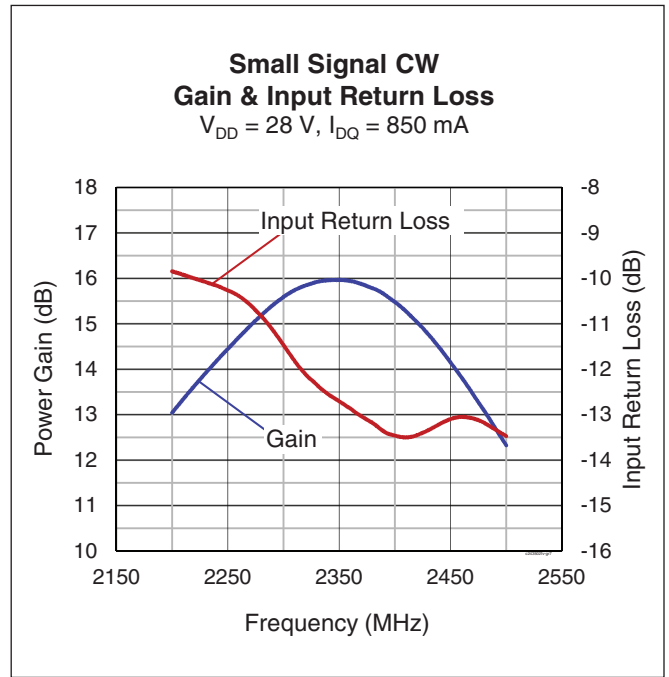
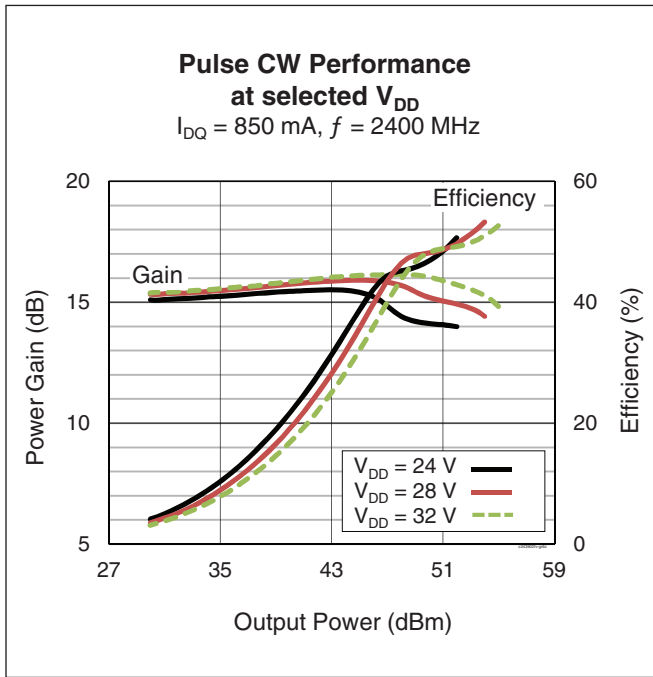

See next page for Load Pull Performance

Load Pull Performance

Main Side – Pulsed CW signal: 160 μ sec, 10% duty cycle; $V_{DD} = 28$ V, $I_{DQ} = 850$ mA

Class AB		P _{1dB}									
		Max Output Power					Max PAE				
Freq [MHz]	Z _s [Ω]	Z _l [Ω]	Gain [dB]	P _{OUT} [dBm]	P _{OUT} [W]	PAE [%]	Z _l [Ω]	Gain [dB]	P _{OUT} [dBm]	P _{OUT} [W]	PAE [%]
2300	6.82 – j9.56	1.28 – j3.64	16.16	52.39	173.38	49.67	2.37 – j2.28	18.79	50.39	109.47	59.01
2350	8.29 – j9.42	1.25 – j3.62	16.44	52.20	165.96	49.05	1.97 – j2.50	18.63	50.66	116.49	57.37
2400	10.06 – j7.29	1.30 – j3.61	16.46	51.82	152.05	45.61	1.99 – j2.24	18.90	50.15	103.49	54.87

Peak Side – Pulsed CW signal: 160 μ sec, 10% duty cycle; $V_{DD} = 28$ V, $I_{DQ} = 1350$ mA

Class AB		P _{1dB}									
		Max Output Power					Max PAE				
Freq [MHz]	Z _s [Ω]	Z _l [Ω]	Gain [dB]	P _{OUT} [dBm]	P _{OUT} [W]	PAE [%]	Z _l [Ω]	Gain [dB]	P _{OUT} [dBm]	P _{OUT} [W]	PAE [%]
2300	3.27 – j6.01	2.09 – j3.76	17.42	53.03	200.91	48.19	1.43 – j2.25	19.79	51.17	130.98	55.51
2350	4.08 – j6.00	2.03 – j3.86	17.54	52.77	189.23	45.76	1.33 – j2.63	19.82	51.31	135.33	53.60
2400	5.14 – j6.25	1.90 – j3.64	18.08	52.61	182.39	45.91	1.49 – j2.71	20.01	51.45	139.57	51.41

Peak Side – Pulsed CW signal: 160 μ sec, 10% duty cycle; $V_{DD} = 28$ V, $V_{GS(peak)} = 1.5$ V

Class C		P _{1dB}									
		Max Output Power					Max PAE				
Freq [MHz]	Z _s [Ω]	Z _l [Ω]	Gain [dB]	P _{OUT} [dBm]	P _{OUT} [W]	PAE [%]	Z _l [Ω]	Gain [dB]	P _{OUT} [dBm]	P _{OUT} [W]	PAE [%]
2300	3.27 – j6.01	1.67 – j4.02	12.90	53.71	234.96	50.13	1.42 – j2.66	14.27	52.51	178.28	59.99
2350	4.08 – j6.00	1.62 – j4.07	13.16	53.57	227.51	50.21	1.37 – j2.69	14.53	51.75	149.62	58.18
2400	5.14 – j6.25	1.96 – j4.15	13.39	53.43	220.29	48.66	1.47 – j2.71	14.74	51.79	150.83	56.64

Reference Circuit, 2300 to 2400 MHz

DUT	PXAC243502FV V1
Test Fixture Part No.	LTA/PXAC243502FV V1
PCB	Rogers 4350, 0.508 mm [.020"] thick, 2 oz. copper, $\epsilon_r = 3.66$
Find Gerber files for this reference fixture on the Wolfspeed Web site at (http://www.wolfspeed.com/RF)	

Reference Circuit (cont.)

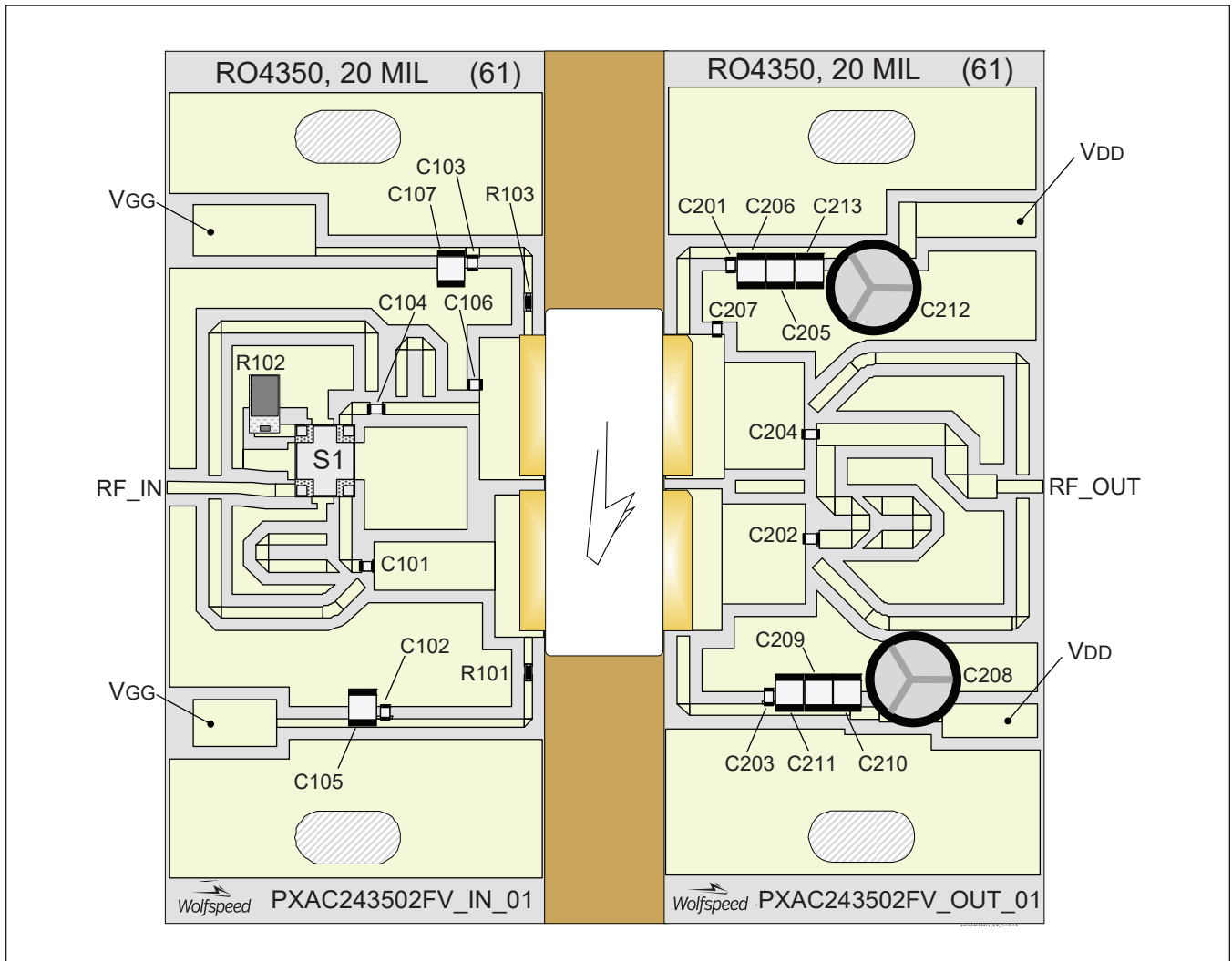

Reference circuit assembly diagram (not to scale)

Component Information

Component	Description	Manufacturer	Part Number
Input			
C101, C102, C103, C104	Capacitor, 15 pF	ATC	ATC600F150JT250XT
C105, C107	Capacitor, 10 μF	Taiyo Yuden	UMK325C7106MM-T
C106	Capacitor, 0.5 pF	ATC	ATC600F0R5BT250XT
R101, R103	Chip resistor, 10 ohms	Panasonic Electronic Components	ERJ-3GEYJ100V
R102	Chip resistor, 50 ohms	Anaren	C16A50Z4
S1	Hybrid coupler	Anaren	X3C25P1-02S

(table cont. next page)



Reference Circuit (cont.)

Component Information (cont.)

Component	Description	Manufacturer	Part Number
Output			
C201, C203	Capacitor, 15 pF	ATC	ATC600F150JT250XT
C207	Capacitor, 0.8 pF	ATC	ATC600F0R8BT250XT
C204	Capacitor, 3 pF	ATC	ATC600F3R0BT250XT
C202	Capacitor, 3.9 pF	ATC	ATC600F3R9BT250XT
C205, C206, C209, C210, C211, C213	Capacitor, 10 μF	Taiyo Yuden	UMK325C7106MM-T
C212, C208	Capacitor, 220 μF	Panasonic Electronic Components	EEE-FP1V221AP

Pinout Diagram (top view)

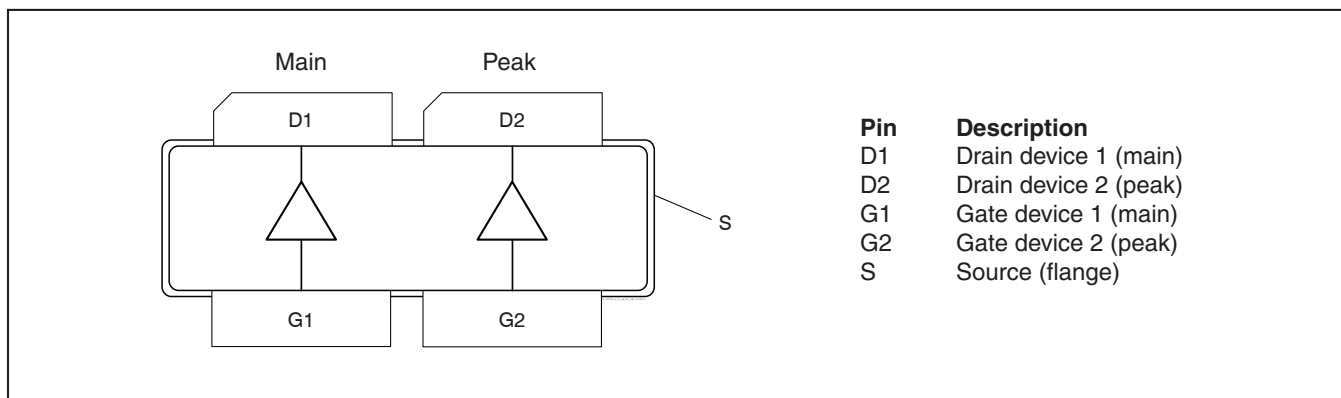

Package Outline Specifications

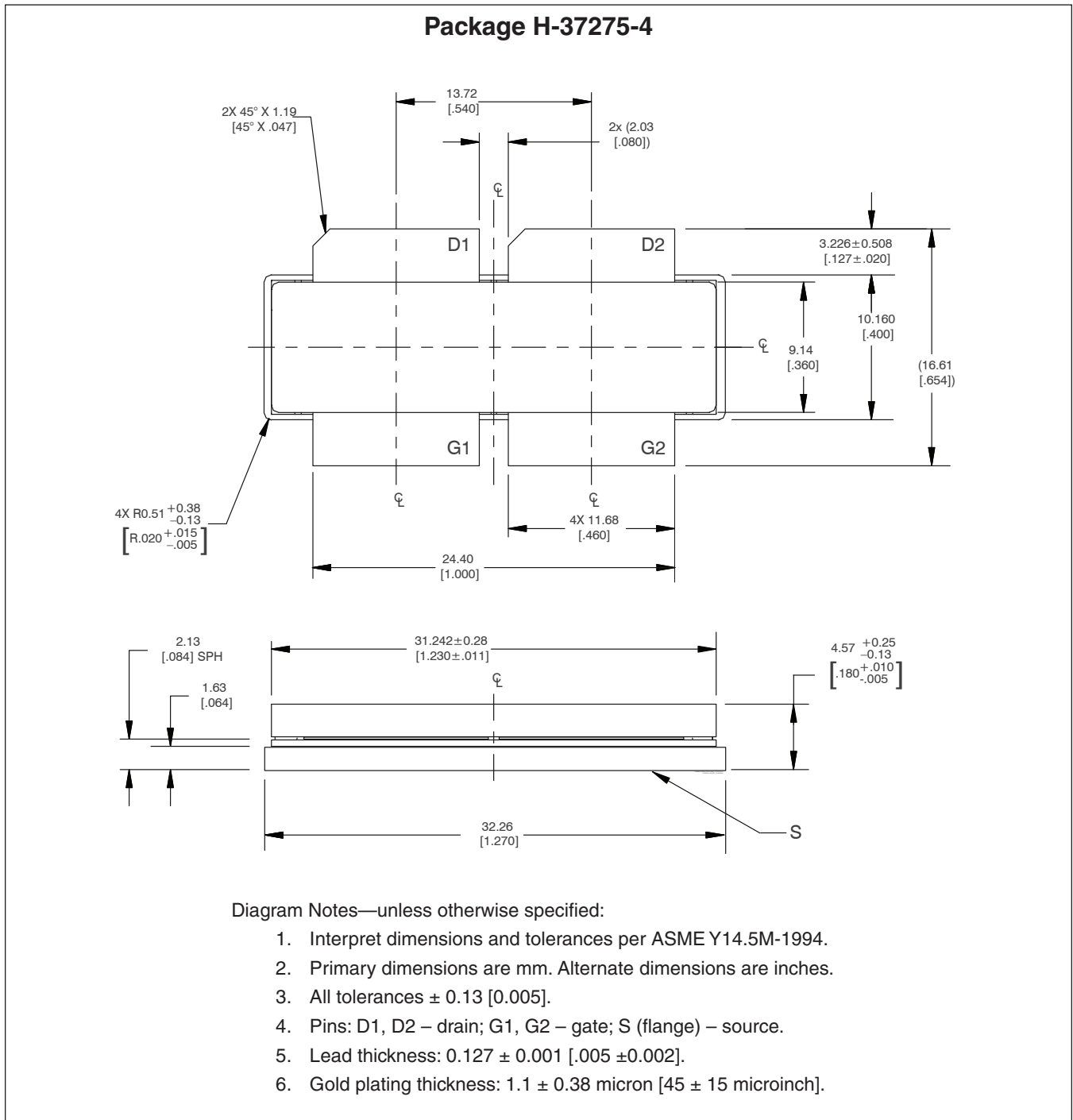

Revision History

Revision	Date	Data Sheet Type	Page	Subjects (major changes since last revision)
01	2013-03-05	Advance	All	Proposed specification for new product development.
02	2014-12-24	Producton	All	Includes released-product specifications, including performance graphs and load pull data.
03	2015-01-16	Production	6 – 8	Include reference circuit information.
03.1	2015-04-13	Production	1, 2	Update RF and DC tables. Removed 1C WCDMA performance from Features, added HBM rating. Updated ordering table.
03.2	2016-06-22	Production	2	Updated ordering information.
04	2018-07-03	Production	All	Converted to Wolfspeed Data Sheet.

For more information, please contact:

4600 Silicon Drive
 Durham, North Carolina, USA 27703
www.wolfspeed.com/RF

Sales Contact
RFSales@wolfspeed.com

RF Product Marketing Contact
RFMarketing@wolfspeed.com
 919.407.7816

Notes

Disclaimer

Specifications are subject to change without notice. Cree, Inc. believes the information contained within this data sheet to be accurate and reliable. However, no responsibility is assumed by Cree for any infringement of patents or other rights of third parties which may result from its use. No license is granted by implication or otherwise under any patent or patent rights of Cree. Cree makes no warranty, representation or guarantee regarding the suitability of its products for any particular purpose. “Typical” parameters are the average values expected by Cree in large quantities and are provided for information purposes only. These values can and do vary in different applications and actual performance can vary over time. All operating parameters should be validated by customer’s technical experts for each application. Cree products are not designed, intended or authorized for use as components in applications intended for surgical implant into the body or to support or sustain life, in applications in which the failure of the Cree product could result in personal injury or death or in applications for planning, construction, maintenance or direct operation of a nuclear facility.



Стандарт Электрон Связь

Мы молодая и активно развивающаяся компания в области поставок электронных компонентов. Мы поставляем электронные компоненты отечественного и импортного производства напрямую от производителей и с крупнейших складов мира.

Благодаря сотрудничеству с мировыми поставщиками мы осуществляем комплексные и плановые поставки широчайшего спектра электронных компонентов.

Собственная эффективная логистика и склад в обеспечивает надежную поставку продукции в точно указанные сроки по всей России.

Мы осуществляем техническую поддержку нашим клиентам и предпродажную проверку качества продукции. На все поставляемые продукты мы предоставляем гарантию .

Осуществляем поставки продукции под контролем ВП МО РФ на предприятия военно-промышленного комплекса России , а также работаем в рамках 275 ФЗ с открытием отдельных счетов в уполномоченном банке. Система менеджмента качества компании соответствует требованиям ГОСТ ISO 9001.

Минимальные сроки поставки, гибкие цены, неограниченный ассортимент и индивидуальный подход к клиентам являются основой для выстраивания долгосрочного и эффективного сотрудничества с предприятиями радиоэлектронной промышленности, предприятиями ВПК и научно-исследовательскими институтами России.

С нами вы становитесь еще успешнее!

Наши контакты:

Телефон: +7 812 627 14 35

Электронная почта: sales@st-electron.ru

Адрес: 198099, Санкт-Петербург,
Промышленная ул, дом № 19, литера Н,
помещение 100-Н Офис 331