

PORTABLE CONSUMER CODEC LOW-POWER, HIGH-FIDELITY INTEGRATED CODEC

ACS422x67

The ACS422x67 is a low-power, high-fidelity integrated CODEC targeted at portable applications such as tablet computers, personal navigation devices, portable projectors and speaker docks. In addition to a high-fidelity low-power CODEC, the device integrates a stereo DDX™ Class D speaker amplifier and a true cap-less headphone amplifier. Beyond high-fidelity for portable systems, the device offers an enriched “audio presence” through built-in audio processing capability.

TARGET APPLICATIONS

- Tablet Computers
- Portable Navigation Devices
- Personal Media Players
- Portable Projectors
- Speaker Docks

FEATURES

- **High fidelity 24-bit stereo CODEC**
 - DAC 102dB SNR; THD+N better than -82dB
 - ADC 90dB SNR, THD + N better than -80dB
- **Built in audio controls and processing**
 - 3D stereo enhancement
 - Dual (cascaded) stereo 6-band parametric equalizers
 - Programmable Compressor/Limiter/Expander
 - Psychoacoustic Bass and Treble enhancement processing
- **Filterless Stereo DDX™ Class D Speaker Driver**

 - 3W/channel (4Ω), 10% THD+N typical
 - 1W/channel (8Ω) or 2W/channel (4Ω), 0.05% THD+N typical
 - Tri-state DDX™ Class D achieves low EMI and high efficiency
 - >80% efficiency at 1W
 - Spread spectrum support for reduced EMI output power mode
 - Anti-Pop circuitry
- **On-chip true cap-less headphone driver**
 - 35 mW output power (16Ω)
 - Charge-pump allows true ground centered outputs
 - SNR of 102dB
- **I2S data interface**
- **Microphone/line-in interface**
 - Analog microphone or line-in inputs
 - Digital microphone (ACS422D67)
 - Automatic level control
- **On-chip low-jitter PLL for audio timing**
- **Supports an external MCLK or XTAL**
 - Optimized for frequencies of 11.2896MHz or 12.288MHz
- **Buffered reference frequency output**
- **Low power with built in power management**
 - 1.7 V CODEC supports 1Vrms
 - Very low standby and no-signal power consumption
 - 1.8V digital / 1.7V analog supply for low power
- **2-wire (I²C compatible) control interface**
- **6x6 mm TLA package and 7x7 mm QFN package**

TABLE OF CONTENTS

1. OVERVIEW 8

 1.1. Block Diagrams 8

 1.2. Audio Outputs 8

 1.3. Audio Inputs 9

2. POWER MANAGEMENT 10

 2.1. Control Registers 10

 2.2. Stopping the Master Clock 11

3. OUTPUT AUDIO PROCESSING 12

 3.1. DC Removal 12

 3.2. Volume Control 13

 3.3. Digital DAC Volume Control 14

 3.4. Parametric Equalizer 14

 3.4.1. Prescaler & Equalizer Filter 14

 3.4.2. EQ Registers 15

 3.4.3. Equalizer, Bass, Treble Coefficient & Equalizer Prescaler RAM 16

 3.5. Gain and Dynamic Range Control 20

 3.6. Limiter 20

 3.7. Compressor 21

 3.7.1. Configuration 22

 3.7.2. Controlling parameters 22

 3.7.3. Overview 23

 3.7.4. Limiter/Compressor Registers 25

 3.7.5. Expander Registers 27

 3.8. Output Effects 28

 3.9. Stereo Depth (3-D) Enhancement 28

 3.10. Psychoacoustic Bass Enhancement 29

 3.11. Psychoacoustic Treble Enhancement 29

 3.12. Mute and De-Emphasis 29

 3.13. Mono Operation and Phase Inversion 29

 3.13.1. DAC Control Register 30

 3.14. Analog Outputs 31

 3.14.1. Headphone Output 31

 3.14.2. Speaker Outputs 32

 3.14.3. DDX™ Class D Audio Processing 32

 3.15. Other Output Capabilities 37

 3.15.1. Audio Output Control 38

 3.15.2. Headphone Switch 38

 3.15.3. Headphone Operation 39

 3.15.4. EQ Operation 39

 3.16. Thermal Shutdown 40

 3.16.1. Algorithm description: 40

 3.16.2. Thermal Trip Points. 40

 3.16.3. Instant Cut Mode 41

 3.16.4. Short Circuit Protection 42

 3.16.5. Thermal Shutdown Registers 42

4. INPUT AUDIO PROCESSING 45

 4.1. Analog Inputs 45

 4.1.1. Input Registers 46

 4.2. Mono Mixing and Output Configuration 46

 4.2.1. ADC Registers 47

 4.3. Microphone Bias 48

 4.3.1. Microphone Bias Control Register 48

 4.4. Programmable Gain Control 48

 4.4.1. Input PGA Software Control Register. 49

 4.5. ADC Digital Filter 49

 4.5.1. ADC Signal Path Control Register 50

 4.5.2. ADC High Pass Filter Enable modes 50

| | |
|---|-----------|
| 4.6. Digital ADC Volume Control | 50 |
| 4.6.1. ADC Digital Registers | 51 |
| 4.7. Automatic Level Control (ALC) | 51 |
| 4.7.1. ALC Operation | 51 |
| 4.7.2. ALC Registers | 53 |
| 4.7.3. Peak Limiter | 54 |
| 4.7.4. Input Threshold | 54 |
| 4.8. Digital Microphone Support | 54 |
| 4.8.1. DMIC Register | 57 |
| 5. DIGITAL AUDIO AND CONTROL INTERFACES | 58 |
| 5.1. Data Interface | 58 |
| 5.2. Master and Slave Mode Operation | 58 |
| 5.3. Audio Data Formats | 59 |
| 5.4. Left Justified Audio Interface | 59 |
| 5.5. Right Justified Audio Interface (assuming n-bit word length) | 59 |
| 5.6. I2S Format Audio Interface | 60 |
| 5.7. Data Interface Registers | 60 |
| 5.7.1. Audio Data Format Control Register | 60 |
| 5.7.2. Audio Interface Output Tri-state | 61 |
| 5.7.3. Audio Interface Bit Clock and LR Clock configuration | 61 |
| 5.7.4. Bit Clock and LR Clock Mode Selection | 62 |
| 5.7.5. ADC Output Pin State | 63 |
| 5.7.6. Audio Interface Control 3 Register | 63 |
| 5.8. Bit Clock Mode | 63 |
| 5.9. Control Interface | 64 |
| 5.9.1. Register Write Cycle | 64 |
| 5.9.2. Multiple Write Cycle | 65 |
| 5.9.3. Register Read Cycle | 65 |
| 5.9.4. Multiple Read Cycle | 66 |
| 5.9.5. Device Addressing and Identification | 66 |
| 6. AUDIO CLOCK GENERATION | 68 |
| 6.1. Internal Clock Generation | 68 |
| 6.1.1. Audio Master Clock (ACLK) | 68 |
| 6.1.2. External MCLK or XTAL | 68 |
| 6.1.3. REF Out | 68 |
| 6.2. ACLK Clocking and Sample Rates | 68 |
| 6.3. DAC/ADC Modulator Rate Control | 71 |
| 7. CHARACTERISTICS | 72 |
| 7.1. Electrical Specifications | 72 |
| 7.1.1. Absolute Maximum Ratings | 72 |
| 7.1.2. Recommended Operating Conditions | 72 |
| 7.2. Device Characteristics | 73 |
| 7.3. PLL Electrical Characteristics | 75 |
| 8. REGISTER MAP | 76 |
| 9. PIN INFORMATION | 78 |
| 9.1. ACS422A67 QFN Pin Diagram | 78 |
| 9.2. ACS422D67 QFN Pin Diagram | 79 |
| 9.3. ACS422A67TAG Pin Diagram | 80 |
| 9.4. ACS422D67 Pin Diagram | 81 |
| 9.5. Pin Tables | 82 |
| 9.5.1. Power Pins | 82 |
| 9.5.2. Reference Pins | 82 |
| 9.5.3. Analog Input Pins | 83 |
| 9.5.4. Analog Output Pins | 83 |
| 9.5.5. Data and Control Pins | 83 |
| 9.5.6. Clock Pins | 84 |
| 10. PACKAGE INFORMATION | 85 |
| 10.1. TAG/TLA Package Drawing | 85 |
| 10.2. TAG/TLA Package Drawing | 86 |

ACS422x67

LOW-POWER, HIGH-FIDELITY, INTEGRATED CODEC

| | |
|---|-----------|
| 10.3. Pb Free Process- Package Classification Reflow Temperatures | 86 |
| 11. APPLICATION INFORMATION | 87 |
| 12. ORDERING INFORMATION | 87 |
| 13. DISCLAIMER | 87 |
| 14. DOCUMENT REVISION HISTORY | 88 |

LIST OF FIGURES

Figure 1. Block Diagram 8

Figure 2. Output Audio Processing 12

Figure 3. Prescaler & EQ Filters 15

Figure 4. DAC Coefficient RAM Write Sequence 17

Figure 5. DAC Coefficient RAM Read Sequence 18

Figure 6. Gain Compressor, Output vs Input 21

Figure 7. Compressor block diagram 23

Figure 8. 3-D Channel Inversion 28

Figure 9. Constant Output Power Error 34

Figure 10. Constant Output Power nominal and high/low 34

Figure 11. Input Audio Processing 45

Figure 12. Mic Bias 48

Figure 13. ADC Filter Data path 49

Figure 14. ALC Operation 51

Figure 15. Single Digital Microphone (data is ported to both left and right channels) 56

Figure 16. Stereo Digital Microphone Configuration 57

Figure 17. Master mode 58

Figure 18. Slave mode 58

Figure 19. Left Justified Audio Interface (assuming n-bit word length) 59

Figure 20. Right Justified Audio Interface (assuming n-bit word length) 59

Figure 21. I2S Justified Audio Interface (assuming n-bit word length) 60

Figure 22. Bit Clock mode 64

Figure 23. 2-Wire Serial Control Interface 65

Figure 24. Multiple Write Cycle 65

Figure 25. Read Cycle 66

Figure 26. Multiple Read Cycle 66

Figure 27. ACS422A67 Pinout 78

Figure 28. ACS422D67 Pinout 79

Figure 29. ACS422A67 Pinout 80

Figure 30. ACS422D67 Pinout 81

Figure 31. Package Outline 85

Figure 32. Package Outline 86

LIST OF TABLES

Table 1. Power Management Register 1 10

Table 2. Power Management Register 2 10

Table 3. Power Management Register1 -- Master Clock Disable 11

Table 4. DC_COEF_SEL Register 12

Table 6. Volume Update Control Register 13

Table 5. CONFIG0 Register 13

Table 7. Gain Control Register 14

Table 8. DAC Volume Control Registers 14

Table 9. CONFIG1 Register 15

Table 10. DACCRAM Read/Write Registers 16

Table 11. DACCRAM Address Register 16

Table 12. DACCRAM Status Register 16

Table 13. DACCRAM EQ Addresses 19

Table 14. DACCRAM Bass/Treble Addresses 19

Table 15. CLECTL Register 25

Table 16. MUGAIN Register 25

Table 17. COMPTH Register 25

Table 18. CMPRAT Register 25

Table 19. CATKTCL Register 25

Table 20. CATKTCH Register 26

Table 21. CRELTCL Register 26

Table 22. CRELTCH Register 26

Table 23. LIMTH Register 26

Table 24. LIMITGT Register 26

Table 25. LATKTCL Register 26

Table 26. LATKTCH Register 26

Table 27. LRELTCL Register 26

Table 28. LRELTCH Register 27

Table 29. EXPTH Register 27

Table 30. EXPRAT Register 27

Table 31. XATKTCL Register 27

Table 32. XATKTCH Register 27

Table 33. XRELTCL Register 27

Table 34. XRELTCH Register 27

Table 35. FX Control Register 28

Table 36. CNVRTR1 Register 30

Table 37. HPVOL L/R Registers 31

Table 38. SPKVOL L/R Registers 32

Table 39. Constant Output Power 1 Register 35

Table 40. Constant Output Power 2 Register 35

Table 41. Constant Output Power 3 Register 36

Table 42. CONFIG0 Register 36

Table 43. PWM0 Register 36

Table 44. PWM1 Register 37

Table 45. PWM2 Register 37

Table 46. PWM3 Register 37

Table 47. Power Management 2 Register 38

Table 48. Additional Control Register 39

Table 49. Headphone Operation 39

Table 50. EQ Operation 39

Table 51. Additional Control Register 42

Table 52. THERMTS Register 43

Table 53. THERMTSPKR1 Register 44

Table 54. THERMTSPKR2 Register 44

Table 55. Input Software Control Register 46

Table 56. INMODE Register 47

Table 57. CNVRTR0 Register 47

Table 58. AIC2 Register 47

ACS422x67

LOW-POWER, HIGH-FIDELITY, INTEGRATED CODEC

| | |
|---|----|
| Table 59. Power Management 1 Register - Mic Bias Enable | 48 |
| Table 60. INVOL L&R Registers | 49 |
| Table 61. CNVRTR0 Register | 50 |
| Table 62. ADC HPF Enable | 50 |
| Table 63. L/R ADC Digital Volume Registers | 51 |
| Table 64. ALC Control Registers | 53 |
| Table 65. NGATE Register | 54 |
| Table 66. DMIC Clock | 55 |
| Table 67. Valid Digital Mic Configurations | 56 |
| Table 68. DMICCTL Register | 57 |
| Table 69. AIC1 Register | 60 |
| Table 70. AIC2 Register | 61 |
| Table 71. Bit Clock and LR Clock Mode Selection | 62 |
| Table 72. ADC Data Output pin state | 63 |
| Table 73. AIC3 Register | 63 |
| Table 74. Master Mode BCLK Frequency Control Register | 64 |
| Table 75. DEVADRI Register | 66 |
| Table 76. DEVID H&L Registers | 67 |
| Table 77. REVID Register | 67 |
| Table 78. RESET Register | 67 |
| Table 79. ADCSR Register | 69 |
| Table 80. DACSR Register | 69 |
| Table 81. ACLK and Sample Rates | 70 |
| Table 82. CONFIG0 Register | 71 |
| Table 83. SDM Rates | 71 |
| Table 84. Electrical Specification: Maximum Ratings | 72 |
| Table 85. Recommended Operating Conditions | 72 |
| Table 86. Device Characteristics | 73 |
| Table 87. PLL Section DC Characteristics | 75 |
| Table 88. Register Map | 76 |
| Table 89. Power Pins | 82 |
| Table 90. Reference Pins | 82 |
| Table 91. Analog Input Pins | 83 |
| Table 92. Analog Output Pins | 83 |
| Table 93. Data and Control Pins | 83 |
| Table 94. Clock Pins | 84 |
| Table 95. Reflow Temperatures | 86 |

ACS422x67

LOW-POWER, HIGH-FIDELITY, INTEGRATED CODEC

1. OVERVIEW

1.1. Block Diagrams

The ACS422x67 is an advanced low power codec with integrated amplifiers and timing generators. To support the design of audio subsystems in a portable device, the ACS422x67 features an intelligent codec architecture with advanced audio processing algorithms, integrated with a true cap-less headphone amplifier, 1W/channel (8Ω) or 2W/channel (4Ω) filterless DDX™ stereo class D amplifier, and microphone interface with programmable gain.

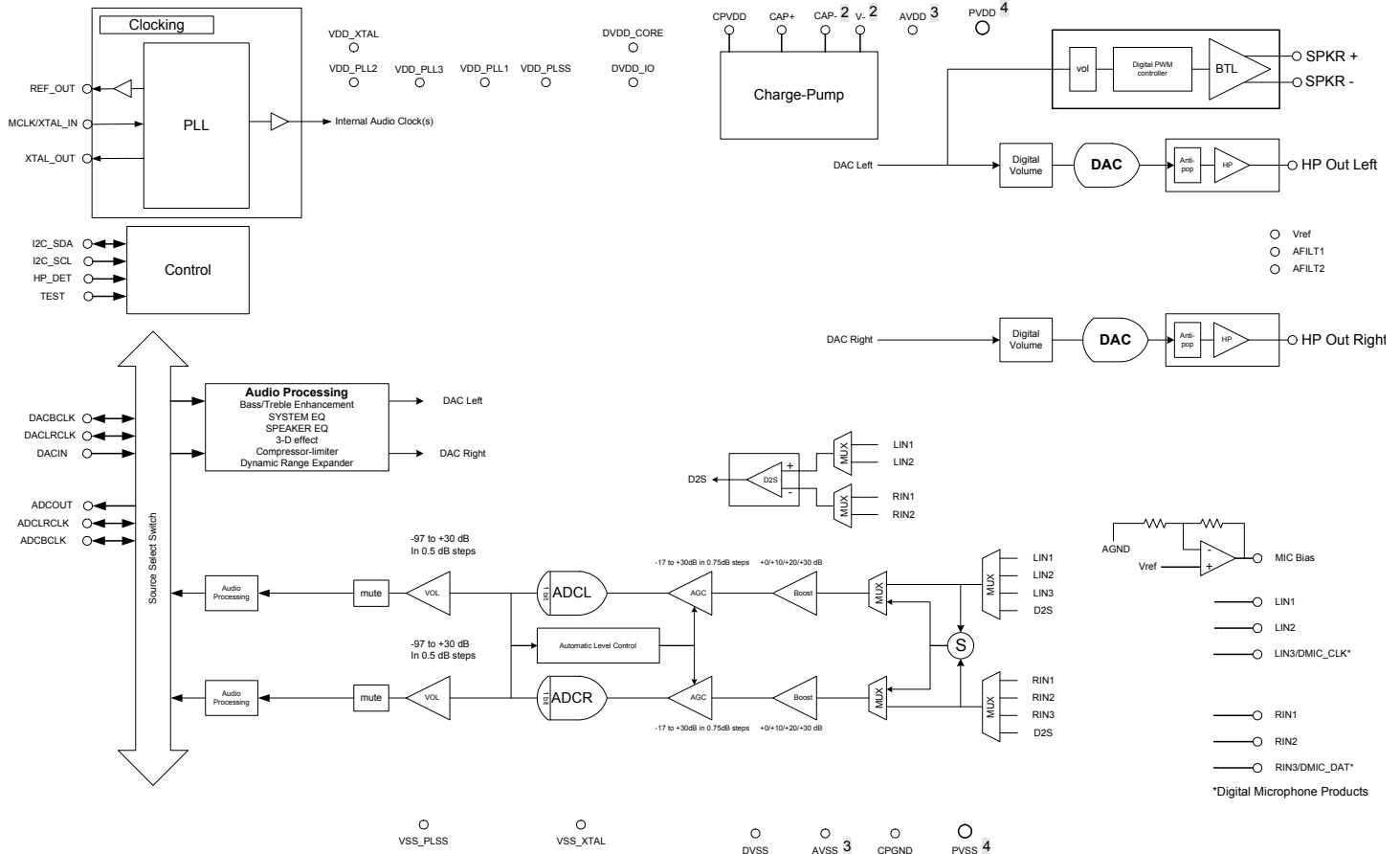

Figure 1. Block Diagram

1.2. Audio Outputs

The ACS422x67 provides multiple outputs for analog sound. Audio outputs include:

- A 1W/channel (8Ω) or 2W/channel (4Ω) **filterless DDX™ Class D amplifier**. This amplifier is capable of driving the speakers typically found in portable equipment, providing high fidelity, high efficiency, and excellent sound quality.
- A **line-out/capless stereo headphone port** with ground referenced outputs, capable of driving headphones without requiring an external DC blocking capacitor.

Each endpoint features independent volume controls, including a soft-mute capability which can slowly ramp up or down the volume changes to avoid unwanted audio artifacts.

The ACS422x67 output signal paths consist of digital filters, DACs and output drivers. The digital filters and DACs are enabled when the ACS422x67 is in 'playback only' or 'record and playback' mode. The output drivers can be separately enabled by individual control bits.

ACS422x67

LOW-POWER, HIGH-FIDELITY, INTEGRATED CODEC

The digital filter and audio processing block processes the data to provide volume control and numerous sound enhancement algorithms. Two high performance sigma-delta audio DACs convert the digital data into analog.

The digital audio data is converted to oversampled bit streams using 24-bit digital interpolation filters, which then enters sigma-delta DACs, and become converted to high quality analog audio signals.

To enhance the sound available from the small, low-power speakers typically found in a portable device, the ACS422x67 provides numerous audio enhancement capabilities. The ACS422x67 features dual, independent, programmable left/right 6-band equalization, allowing the system designer to provide an advanced system equalizer to accommodate the specific speakers and enclosure design. A compressor/limiter features programmable attack and release thresholds, enabling the system designer to attenuate loud noise excursions to avoid speaker artifacts, thus allowing the underlying content to be played at a louder volume without distortion. For compressed audio, a programmable expander is available to help restore the dynamic range of the original content. A stereo depth enhancement algorithm allows common left/right content (e.g. dialog) to be attenuated separately from other content, providing a perceived depth separation between background and foreground audio. Psychoacoustic bass and treble enhancement algorithms achieve a rich, full tone even from originally compressed content, and even with speakers generally unable to play low-frequency sounds.

1.3. Audio Inputs

On the analog input side, the device features multiple line-in/microphone inputs, which can be used for analog microphone, or line-in inputs. In addition, digital microphones are also supported. The device provides input gain control, separate volume controls, automatic leveling capability, and programmable microphone boost to smooth input recording. A programmable silence “floor” or “threshold” can be set to minimize background noise.

2. POWER MANAGEMENT

2.1. Control Registers

The ACS422x67 has control registers to enable system software to control which functions are active. To minimize power consumption, unused functions should be disabled. To avoid audio artifacts, it is important to enable or disable functions in the correct order.

| Register Address | Bit | Label | Type | Default | Description |
|----------------------------|-----|--------|------|---------|---|
| 0x1A Power Management 1 | 7 | BSTL | RW | 0 | Analog in Boost Left 0 = Power down, 1 = Power up |
| | 6 | BSTR | RW | 0 | Analog in Boost Right 0 = Power down, 1 = Power up |
| | 5 | PGAL | RW | 0 | Analog in PGA Left 0 = Power down, 1 = Power up |
| | 4 | PGAR | RW | 0 | Analog in PGA Right 0 = Power down, 1 = Power up |
| | 3 | ADCL | RW | 0 | ADC Left 0 = Power down, 1 = Power up |
| | 2 | ADCR | RW | 0 | ADC Right 0 = Power down, 1 = Power up |
| | 1 | MICB | RW | 0 | MICBIAS 0 = Power down, 1 = Power up |
| | 0 | DIGENB | RW | 0 | Master clock disable 0: master clock enabled, 1: master clock disabled |

Table 1. Power Management Register 1

| Register Address | Bit | Label | Type | Default | Description |
|----------------------------|-----|--------|------|---------|--|
| 0x1B Power Management 2 | 7 | D2S | RW | 0 | Analog in D2S AMP 0 = Power down, 1 = Power up |
| | 6 | HPL | RW | 0 | LHP Output Buffer + DAC 0 = Power down, 1 = Power up |
| | 5 | HPR | RW | 0 | RHP Output Buffer + DAC 0 = Power down, 1 = Power up |
| | 4 | SPKL | RW | 0 | LSPK Output Buffer 0 = Power down, 1 = Power up |
| | 3 | SPKR | RW | 0 | RSPK Output Buffer 0 = Power down, 1 = Power up |
| | 2 | INSELL | RW | 0 | Analog in Select Mux Left 0 = Power down, 1 = Power up |
| | 1 | INSELR | RW | 0 | Analog in Select Mux Right 0 = Power down, 1 = Power up |
| | 0 | VREF | RW | 0 | VREF (necessary for all other functions) 0 = Power down, 1 = Power up |

Table 2. Power Management Register 2

2.2. Stopping the Master Clock

In order to minimize digital core power consumption, the master clock may be stopped in Standby and OFF modes by setting the DIGENB bit (R25, bit 0).

| Register Address | Bit | Label | Type | Default | Description |
|----------------------------|-----|--------|------|---------|---|
| 0x1A Power Management 1 | 0 | DIGENB | RW | 0 | Master clock disable 0 = master clock enabled, 1 = master clock disabled |

Table 3. Power Management Register1 -- Master Clock Disable

Note: Before DIGENB can be set, the control bits ADCL, ADCR, HPL, HPR, SPKL, and SPKR must be set to zero and a waiting time of 100ms must be observed to allow port ramping/gain fading to complete. Any failure to follow this procedure may cause pops or, if less than 1mS, may prevent the DACs and ADCs from re-starting correctly.

3. OUTPUT AUDIO PROCESSING

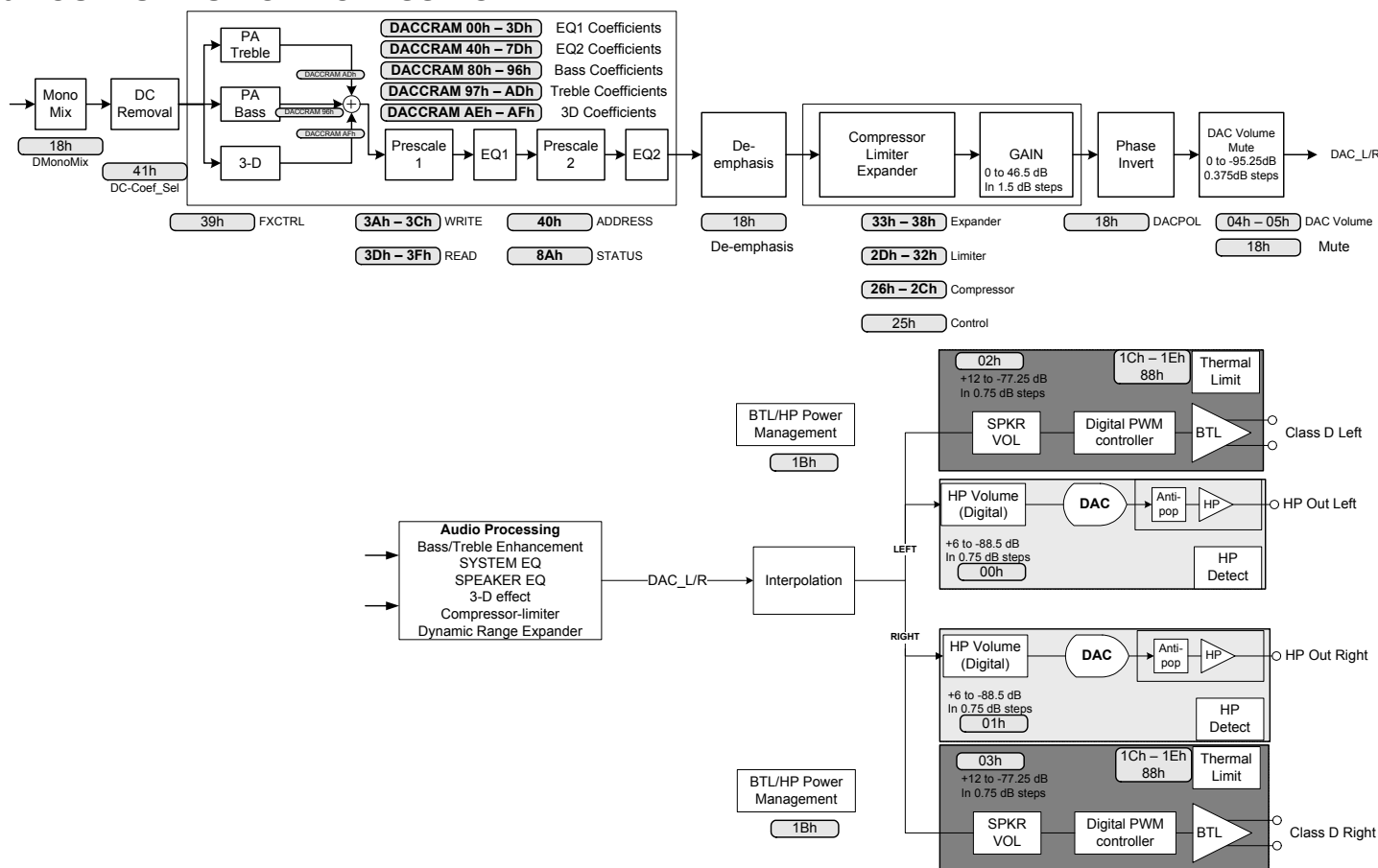

Figure 3. Output Audio Processing

3.1. DC Removal

Before processing, a DC removal filter removes the DC component from the incoming audio data. The DC removal filter is programmable.

| Register Address | Bit | Label | Type | Default | Description |
|----------------------|-----|-------|------|---------|---|
| R65 (41h) DCOFSEL | 7:3 | - | R | 0 | Reserved for future use. |
| | 2:0 | - | RW | 5 | 0: dc_coef = 24'h100000; //2 ⁻³ = 0.125 1: dc_coef = 24'h040000; 2: dc_coef = 24'h010000; 3: dc_coef = 24'h004000; 4: dc_coef = 24'h001000; 5: dc_coef = 24'h000400; 6: dc_coef = 24'h000100; //2 ⁻¹⁵ = 0.00030517 7: dc_coef = 24'h000040; //2 ⁻¹⁷ |

Table 4. DC_COEF_SEL Register

| Register Address | Bit | Label | Type | Default | Description |
|----------------------|-----|-----------|------|---------|---|
| R31 (1Fh) CONFIG0 | 7:6 | ASDM[1:0] | RW | 10h | ADC Modulator Rate |
| | 5:4 | DSDM[1:0] | RW | 10h | DAC Modulator Rate |
| | 3:2 | RSVD | R | 0h | Reserved for future use. |
| | 1 | dc_bypass | RW | 0 | 1 = bypass DC removal filter (WARNING DC content can damage speakers) |
| | 0 | RSVD | R | 0 | Reserved |

Table 5. CONFIG0 Register

3.2. Volume Control

The signal volume can be controlled digitally, across a gain and attenuation range of -95.25dB to 0dB (0.375dB steps). The level of attenuation is specified by an eight-bit code, 'DACVOL_x', where 'x' is L, or R. The value "00000000" indicates mute; other values select the number of 0.375dB steps above -95.625dB for the volume level.

The Volume Update bits control the updating of volume control data; when a bit is written as '0', the Left Volume control associated with that bit is updated whenever the left volume register is written and the Right Volume control is updated when ever the right volume register is written. When a bit is written as '1', the left volume data is placed into an internal holding register when the left volume register is written and both the left and right volumes are updated when the right volume register is written. This enables a simultaneous left and right volume update

| Register Address | Bit | Label | Type | Default | Description |
|--------------------|-----|---------|------|---------|--|
| R10 (0Ah) VUCTL | 7 | ADCFade | RW | 1 | 1 = volume fades between old/new value 0 = volume/mute changes immediately |
| | 6 | DACFade | RW | 1 | 1 = volume fades between old/new value 0 = volume/mute changes immediately |
| | 5 | RSVD | R | 0 | Reserved for future use. |
| | 4 | INVOLU | RW | 0 | 0 = Left input volume updated immediately 1 = Left input volume held until right input volume register written. |
| | 3 | ADCVOLU | RW | 0 | 0 = Left ADC volume updated immediately 1 = Left ADC volume held until right ADC volume register written. |
| | 2 | DACVOLU | RW | 0 | 0 = Left DAC volume updated immediately 1 = Left DAC volume held until right DAC volume register written. |
| | 1 | SPKVOLU | RW | 0 | 0 = Left speaker volume updated immediately 1 = Left speaker volume held until right speaker volume register written. |
| | 0 | HPVOLU | RW | 0 | 0 = Left headphone volume updated immediately 1 = Left headphone volume held until right headphone volume register written. |

Table 6. Volume Update Control Register

The output path may be muted automatically when a long string of zero data is received. The length of zeros is programmable and a detection flag indicates when a stream of zero data has been detected.

| Register Address | Bit | Label | Type | Default | Description |
|--|-----|--------------|------|---------|---|
| R33 (21h) Gain Control (GAINCTL) | 7 | zerodet_flag | R | 0 | 1 = zero detect length exceeded. |
| | 6 | RSVD | R | 0 | Reserved for future use. |
| | 5:4 | zerodetlen | RW | 2 | Enable mute if input consecutive zeros exceeds this length. 0 = 512, 1 = 1k, 2 = 2k, 3 = 4k samples |
| | 3 | RSVD | R | 0 | Reserved for future use. |
| | 2 | auto_mute | RW | 1 | 1 = auto mute if detect long string of zeros on input |
| | 1 | RSVD | R | 0 | Reserved for future use. |
| | 0 | RSVD | R | 0 | Reserved for future use. |
| | 7 | zerodet_flag | R | 0 | 1 = zero detect length exceeded. |

Table 7. Gain Control Register

3.3. Digital DAC Volume Control

The signal volume can be controlled digitally, across a gain and attenuation range of -95.25dB to 0dB (0.375dB steps). The level of attenuation is specified by an eight-bit code, 'DACVOL_x', where 'x' is L, or R. The value "00000000" indicates mute; other values select the number of 0.375dB steps above -95.625dB for the volume level.

| Register Address | Bit | Label | Type | Default | Description |
|---|-----|-------------------|------|-------------|---|
| R4 (04h) Left DAC Volume Control | 7:0 | DACVOL_L [7:0] | RW | FF (0dB) | Left DAC Volume Level 0000 0000 = Digital Mute 0000 0001 = -95.25dB 0000 0010 = -94.875dB ... 0.375dB steps up to 1111 1111 = 0dB Note: If DACVOLUME is set, this setting will take effect after the next write to the Right Input Volume register. |
| R5 (05h) Right DAC Volume Control | 7:0 | DACVOL_R [7:0] | RW | FF (0dB) | Right DAC Digital Volume Level 0000 0000 = Digital Mute 0000 0001 = -95.25dB 0000 0010 = -94.875dB ... 0.375dB steps up to 1111 1111 = 0dB |

Table 8. DAC Volume Control Registers

3.4. Parametric Equalizer

The ACS422x67 has a dual 6-band digital parametric equalizer to enable fine tuning of the audio response and preferences for a given system. Each EQ may be enabled or disabled independently. Typically one EQ will be used for speaker compensation and disabled when only headphones are in use while the other EQ is used to alter the audio to make it more pleasing to the listener. This function operates on the digital audio data before it is converted back to analog by the audio DACs.

3.4.1. Prescaler & Equalizer Filter

The Equalizer Filter consists of a Prescaler and 6 IIR Filters. The Prescaler allows the input to be attenuated prior to the EQ filters in case the EQ filters introduce gain, and would thus clip if not prescaled.

TSI provides a tool to enable an audio designer to determine appropriate coefficients for the equalizer filters. The filters enable the implementation of a parametric equalizer with selectable frequency bands, gain, and filter characteristics (high, low, or bandpass).

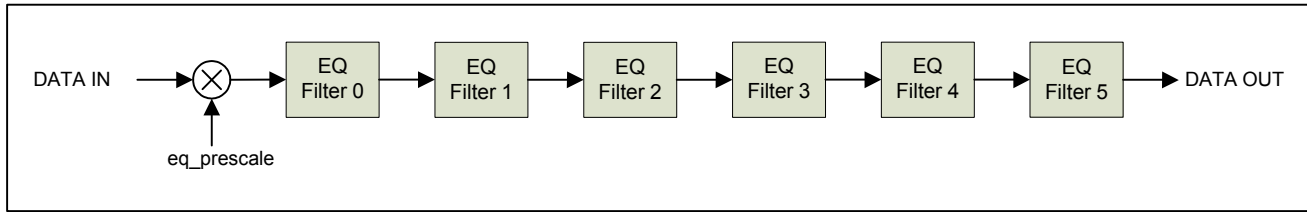

Figure 4. Prescaler & EQ Filters

3.4.2. EQ Registers

- EQ Filter Enable Register

| Register Address | Bit | Label | Type | Default | Description |
|----------------------|-----|-------------|------|---------|---|
| R32 (20h) CONFIG1 | 7 | EQ2_EN | R/W | 0 | EQ bank 2 enable 0 = second EQ bypassed, 1 = second EQ enabled |
| | 6:4 | EQ2_BE[2:0] | R/W | 0 | EQ2 band enable. When the EQ is enabled the following EQ stages are executed. 0 - Prescale only 1 - Prescale and Filter Band 0 ... 6 - Prescale and Filter Bands 0 to 5 7 - RESERVED |
| | 3 | EQ1_EN | R/W | 0 | EQ bank 1 enable 0 = first EQ bypassed, 1 = first EQ enabled |
| | 2:0 | EQ1_BE[2:0] | R/W | 0 | EQ1 band enable. When the EQ is enabled the following EQ stages are executed. 0 - Prescale only 1 - Prescale and Filter Band 0 ... 6 - Prescale and Filter Bands 0 to 5 7 - RESERVED |

Table 9. CONFIG1 Register

- DACCRAM Read Data (0x3D–LO, 0x3E–MID, 0x3F–HI), DACCRAM Write Data (0x3A–LO, 0x3B–MID, 0x3C–HI) Registers**
These two 24-bit registers provide the 24-bit data holding registers used when doing indirect writes/reads to the DAC

ACS422x67

LOW-POWER, HIGH-FIDELITY, INTEGRATED CODEC

Coefficient RAM.

| Register Address | Bit | Label | Type | Default | Description |
|--------------------------------|-----|----------------|------|---------|---|
| R58 (3Ah) DACCRAM_WRITE_LO | 7:0 | DACCRWD[7:0] | R/W | 0 | Low byte of a 24-bit data register, contains the values to be written to the DACCRAM. The address written will have been specified by the DACCRAM Address fields. |
| R59 (3Bh) DACCRAM_WRITE_MID | 7:0 | DACCRWD[15:8] | R/W | 0 | Middle byte of a 24-bit data register, contains the values to be written to the DACCRAM. The address written will have been specified by the DACCRAM Address fields. |
| R60 (3Ch) DACCRAM_WRITE_HI | 7:0 | DACCRWD[23:16] | R/W | 0 | High byte of a 24-bit data register, contains the values to be written to the DACCRAM. The address written will have been specified by the DACCRAM Address fields. |
| R61 (3Dh) DACCRAM_READ_LO | 7:0 | DACCRRD[7:0] | R | 0 | Low byte of a 24-bit data register, contains the contents of the most recent DACCRAM address read from the RAM. The address read will have been specified by the DACCRAM Address fields. |
| R62 (3Eh) DACCRAM_READ_MID | 7:0 | DACCRRD[15:8] | R | 0 | Middle byte of a 24-bit data register, contains the contents of the most recent DACCRAM address read from the RAM. The address read will have been specified by the DACCRAM Address fields. |
| R63 (3Fh) DACCRAM_READ_HI | 7:0 | DACCRRD[23:16] | R | 0 | High byte of a 24-bit data register, contains the contents of the most recent DACCRAM address read from the RAM. The address read will have been specified by the DACCRAM Address fields. |

Table 10. DACCRAM Read/Write Registers

- **DACCRAM Address Register**

This 7-bit register provides the address to the internal RAM when doing indirect writes/reads to the DAC Coefficient RAM.

| Register Address | Bit | Label | Type | Default | Description |
|------------------------|-----|----------|------|---------|--|
| R64 (40h) DACCRADDR | 7:0 | DACCRADD | R/W | 0 | Contains the address (between 0 and 255) of the DACCRAM to be accessed by a read or write. This is not a byte address--it is the address of the 24-bit data item to be accessed from the DACCRAM. This address is automatically incremented after writing to DACCRAM_WRITE_HI or reading from DACCRAM_READ_HI (and the 24 bit data from the next RAM location is fetched.) |

Table 11. DACCRAM Address Register

- **DACCRAM STATUS Register**

This control register provides the write/read enable when doing indirect writes/reads to the DAC Coefficient RAM.

| Register Address | Bit | Label | Type | Default | Description |
|-------------------------|-----|--------------|------|---------|---|
| R138 (8Ah) DACCRSTAT | 7 | DACCRAM_Busy | R | 0 | 1 = read/write to DACCRAM in progress, cleared by HW when done. |
| | 6:0 | RSVD | R | 0 | Reserved |

Table 12. DACCRAM Status Register

3.4.3. Equalizer, Bass, Treble Coefficient & Equalizer Prescaler RAM

The DAC Coefficient RAM is a single port 161x24 synchronous RAM. It is programmed indirectly through the Control Bus in the following manner:

1. Write target address to DACCRAM_ADDR register.
2. Write D7:0 to the DACCRAM_WRITE_LO register
3. Write D15:8 to the DACCRAM_WRITE_MID register
4. Write D23:16 to the DACCRAM_WRITE_HI register
5. On successful receipt of the DACCRAM_WRITE_HI data, the part will automatically start a write cycle. The DACCRAM_Busy bit will be set high to indicate that a write is in progress.
6. On completion of the internal write cycle, the DACCRAM_Busy bit will be 0 (when operating the control interface at high speeds - TBD - software must poll this bit to ensure the write cycle is complete before starting another write cycle.)
7. The bus cycle may be terminated by the host or steps 2-6 may be repeated for writes to consecutive EQ RAM locations.

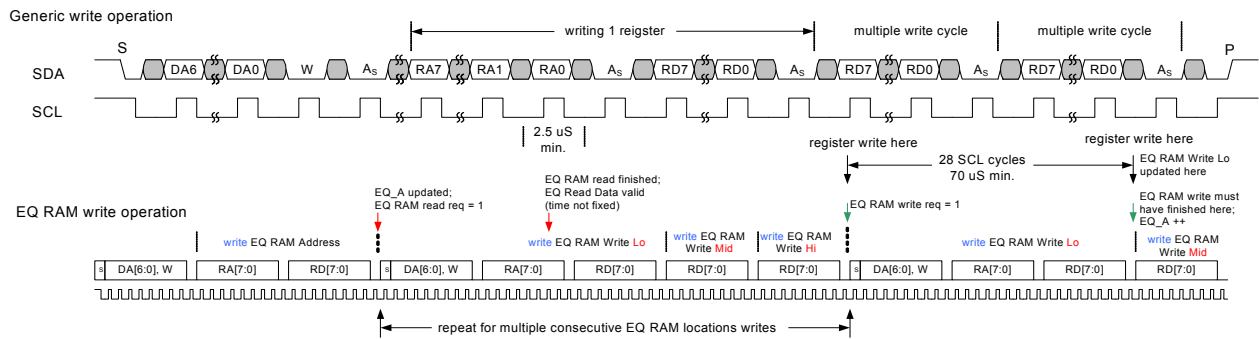

Figure 5. DAC Coefficient RAM Write Sequence

Reading back a value from the DACCRAM is done in this manner:

1. Write target address to DACCRAM_ADDR register.(EQ data is pre-fetched for read even if we don't use it)
2. Start (or repeat start) a write cycle to DACCRAM_READ_LO and after the second byte (register address) is acknowledged, go to step 3. (Do not complete the write cycle.)
3. Signal a repeat start and indicate a read operation
4. Read D7:0 (register address incremented after ack by host)
5. Read D15:8 (register address incremented after ack by host)
6. Read D23:16 (register address incremented and next EQ location pre-fetched after ack by host)
7. The host stops the bus cycle

To repeat a read cycle for consecutive EQ RAM locations:

1. Start (or repeat start instead of stopping the bus cycle in step 7) a write cycle indicating DACCRAM_RD_LO as the target address.
2. After the second byte is acknowledged, signal a repeated start.
3. Indicate a read operation
4. Read the DACCRAM_READ_LO register as described in step 4
5. Read the DACCRAM_READ_MID register as described in step 5
6. Read the DACCRAM_READ_HI register as described in step 6

7. Repeat steps 8-13 as desired

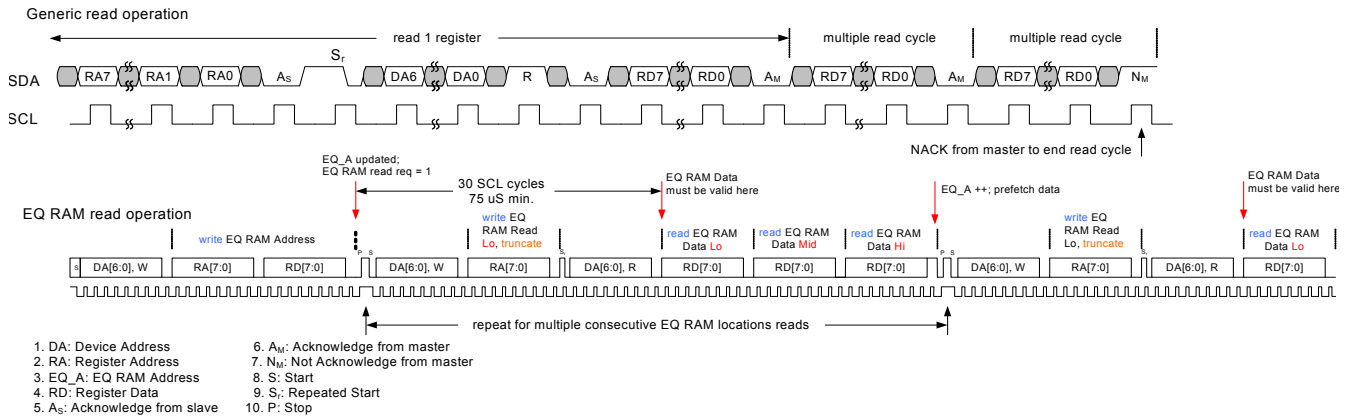

Figure 6. DAC Coefficient RAM Read Sequence

• DACCRAM EQ Addresses

| EQ 0 | | | | EQ1 | | | |
|------|------------------------|------|------------------------|------|------------------------|------|------------------------|
| Addr | Channel 0 Coefficients | Addr | Channel 1 Coefficients | Addr | Channel 0 Coefficients | Addr | Channel 1 Coefficients |
| 0x00 | EQ_COEF_0F0_B0 | 0x20 | EQ_COEF_1F0_B0 | 0x40 | EQ_COEF_2F0_B0 | 0x60 | EQ_COEF_3F0_B0 |
| 0x01 | EQ_COEF_0F0_B1 | 0x21 | EQ_COEF_1F0_B1 | 0x41 | EQ_COEF_2F0_B1 | 0x61 | EQ_COEF_3F0_B1 |
| 0x02 | EQ_COEF_0F0_B2 | 0x22 | EQ_COEF_1F0_B2 | 0x42 | EQ_COEF_2F0_B2 | 0x62 | EQ_COEF_3F0_B2 |
| 0x03 | EQ_COEF_0F0_A1 | 0x23 | EQ_COEF_1F0_A1 | 0x43 | EQ_COEF_2F0_A1 | 0x63 | EQ_COEF_3F0_A1 |
| 0x04 | EQ_COEF_0F0_A2 | 0x24 | EQ_COEF_1F0_A2 | 0x44 | EQ_COEF_2F0_A2 | 0x64 | EQ_COEF_3F0_A2 |
| 0x05 | EQ_COEF_0F1_B0 | 0x25 | EQ_COEF_1F1_B0 | 0x45 | EQ_COEF_2F1_B0 | 0x65 | EQ_COEF_3F1_B0 |
| 0x06 | EQ_COEF_0F1_B1 | 0x26 | EQ_COEF_1F1_B1 | 0x46 | EQ_COEF_2F1_B1 | 0x66 | EQ_COEF_3F1_B1 |
| 0x07 | EQ_COEF_0F1_B2 | 0x27 | EQ_COEF_1F1_B2 | 0x47 | EQ_COEF_2F1_B2 | 0x67 | EQ_COEF_3F1_B2 |
| 0x08 | EQ_COEF_0F1_A1 | 0x28 | EQ_COEF_1F1_A1 | 0x48 | EQ_COEF_2F1_A1 | 0x68 | EQ_COEF_3F1_A1 |
| 0x09 | EQ_COEF_0F1_A2 | 0x29 | EQ_COEF_1F1_A2 | 0x49 | EQ_COEF_2F1_A2 | 0x69 | EQ_COEF_3F1_A2 |
| 0x0A | EQ_COEF_0F2_B0 | 0x2A | EQ_COEF_1F2_B0 | 0x4A | EQ_COEF_2F2_B0 | 0x6A | EQ_COEF_3F2_B0 |
| 0x0B | EQ_COEF_0F2_B1 | 0x2B | EQ_COEF_1F2_B1 | 0x4B | EQ_COEF_2F2_B1 | 0x6B | EQ_COEF_3F2_B1 |
| 0x0C | EQ_COEF_0F2_B2 | 0x2C | EQ_COEF_1F2_B2 | 0x4C | EQ_COEF_2F2_B2 | 0x6C | EQ_COEF_3F2_B2 |
| 0x0D | EQ_COEF_0F2_A1 | 0x2D | EQ_COEF_1F2_A1 | 0x4D | EQ_COEF_2F2_A1 | 0x6D | EQ_COEF_3F2_A1 |
| 0x0E | EQ_COEF_0F2_A2 | 0x2E | EQ_COEF_1F2_A2 | 0x4E | EQ_COEF_2F2_A2 | 0x6E | EQ_COEF_3F2_A2 |
| 0x0F | EQ_COEF_0F3_B0 | 0x2F | EQ_COEF_1F3_B0 | 0x4F | EQ_COEF_2F3_B0 | 0x6F | EQ_COEF_3F3_B0 |
| 0x10 | EQ_COEF_0F3_B1 | 0x30 | EQ_COEF_1F3_B1 | 0x50 | EQ_COEF_2F3_B1 | 0x70 | EQ_COEF_3F3_B1 |
| 0x11 | EQ_COEF_0F3_B2 | 0x31 | EQ_COEF_1F3_B2 | 0x51 | EQ_COEF_2F3_B2 | 0x71 | EQ_COEF_3F3_B2 |
| 0x12 | EQ_COEF_0F3_A1 | 0x32 | EQ_COEF_1F3_A1 | 0x52 | EQ_COEF_2F3_A1 | 0x72 | EQ_COEF_3F3_A1 |

ACS422x67

LOW-POWER, HIGH-FIDELITY, INTEGRATED CODEC

| EQ 0 | | | | EQ1 | | | |
|------|------------------------|------|------------------------|------|------------------------|------|------------------------|
| Addr | Channel 0 Coefficients | Addr | Channel 1 Coefficients | Addr | Channel 0 Coefficients | Addr | Channel 1 Coefficients |
| 0x13 | EQ_COEF_0F3_A2 | 0x33 | EQ_COEF_1F3_A2 | 0x53 | EQ_COEF_2F3_A2 | 0x73 | EQ_COEF_3F3_A2 |
| 0x14 | EQ_COEF_0F4_B0 | 0x34 | EQ_COEF_1F4_B0 | 0x54 | EQ_COEF_2F4_B0 | 0x74 | EQ_COEF_3F4_B0 |
| 0x15 | EQ_COEF_0F4_B1 | 0x35 | EQ_COEF_1F4_B1 | 0x55 | EQ_COEF_2F4_B1 | 0x75 | EQ_COEF_3F4_B1 |
| 0x16 | EQ_COEF_0F4_B2 | 0x36 | EQ_COEF_1F4_B2 | 0x56 | EQ_COEF_2F4_B2 | 0x76 | EQ_COEF_3F4_B2 |
| 0x17 | EQ_COEF_0F4_A1 | 0x37 | EQ_COEF_1F4_A1 | 0x57 | EQ_COEF_2F4_A1 | 0x77 | EQ_COEF_3F4_A1 |
| 0x18 | EQ_COEF_0F4_A2 | 0x38 | EQ_COEF_1F4_A2 | 0x58 | EQ_COEF_2F4_A2 | 0x78 | EQ_COEF_3F4_A2 |
| 0x19 | EQ_COEF_0F5_B0 | 0x39 | EQ_COEF_1F5_B0 | 0x59 | EQ_COEF_2F5_B0 | 0x79 | EQ_COEF_3F5_B0 |
| 0x1A | EQ_COEF_0F5_B1 | 0x3A | EQ_COEF_1F5_B1 | 0x5A | EQ_COEF_2F5_B1 | 0x7A | EQ_COEF_3F5_B1 |
| 0x1B | EQ_COEF_0F5_B2 | 0x3B | EQ_COEF_1F5_B2 | 0x5B | EQ_COEF_2F5_B2 | 0x7B | EQ_COEF_3F5_B2 |
| 0x1C | EQ_COEF_0F5_A1 | 0x3C | EQ_COEF_1F5_A1 | 0x5C | EQ_COEF_2F5_A1 | 0x7C | EQ_COEF_3F5_A1 |
| 0x1D | EQ_COEF_0F5_A2 | 0x3D | EQ_COEF_1F5_A2 | 0x5D | EQ_COEF_2F5_A2 | 0x7D | EQ_COEF_3F5_A2 |
| 0x1E | - | 0x3E | - | 0x5E | - | 0x7E | - |
| 0x1F | EQ_PRESCALE0 | 0x3F | EQ_PRESCALE1 | 0x5F | EQ_PRESCALE2 | 0x7F | EQ_PRESCALE3 |

Table 13. DACCRAM EQ Addresses

- DACCRAM Bass/Treble Addresses**

| Addr | Bass Coefficients ¹ | Addr | Treble Coefficients | Addr | 3D Coefficients |
|------|--------------------------------|------|---------------------|------|-----------------|
| 0x80 | BASS_COEF_EXT1_B0 | 0x97 | TREB_COEF_EXT1_B0 | 0xAE | 3D_COEF |
| 0x81 | BASS_COEF_EXT1_B1 | 0x98 | TREB_COEF_EXT1_B1 | 0xAF | 3D_MIX |
| 0x82 | BASS_COEF_EXT1_B2 | 0x99 | TREB_COEF_EXT1_B2 | | |
| 0x83 | BASS_COEF_EXT1_A1 | 0x9A | TREB_COEF_EXT1_A1 | | |
| 0x84 | BASS_COEF_EXT1_A2 | 0x9B | TREB_COEF_EXT1_A2 | | |
| 0x85 | BASS_COEF_EXT2_B0 | 0x9C | TREB_COEF_EXT2_B0 | | |
| 0x86 | BASS_COEF_EXT2_B1 | 0x9D | TREB_COEF_EXT2_B1 | | |
| 0x87 | BASS_COEF_EXT2_B2 | 0x9E | TREB_COEF_EXT2_B2 | | |
| 0x88 | BASS_COEF_EXT2_A1 | 0x9F | TREB_COEF_EXT2_A1 | | |
| 0x89 | BASS_COEF_EXT2_A2 | 0xA0 | TREB_COEF_EXT2_A2 | | |
| 0x8A | BASS_COEF_NLF_M1 ² | 0xA1 | TREB_COEF_NLF_M1 | | |
| 0x8B | BASS_COEF_NLF_M2 | 0xA2 | TREB_COEF_NLF_M2 | | |
| 0x8C | BASS_COEF_LMT_B0 | 0xA3 | TREB_COEF_LMT_B0 | | |
| 0x8D | BASS_COEF_LMT_B1 | 0xA4 | TREB_COEF_LMT_B1 | | |

Table 14. DACCRAM Bass/Treble Addresses

ACS422x67

LOW-POWER, HIGH-FIDELITY, INTEGRATED CODEC

| Addr | Bass Coefficients ¹ | Addr | Treble Coefficients | Addr | 3D Coefficients |
|------|--------------------------------|------|---------------------|------|-----------------|
| 0x8E | BASS_COEF_LMT_B2 | 0xA5 | TREB_COEF_LMT_B2 | | |
| 0x8F | BASS_COEF_LMT_A1 | 0xA6 | TREB_COEF_LMT_A1 | | |
| 0x90 | BASS_COEF_LMT_A2 | 0xA7 | TREB_COEF_LMT_A2 | | |
| 0x91 | BASS_COEF_CTO_B0 | 0xA8 | TREB_COEF_CTO_B0 | | |
| 0x92 | BASS_COEF_CTO_B1 | 0xA9 | TREB_COEF_CTO_B1 | | |
| 0x93 | BASS_COEF_CTO_B2 | 0xAA | TREB_COEF_CTO_B2 | | |
| 0x94 | BASS_COEF_CTO_A1 | 0xAB | TREB_COEF_CTO_A1 | | |
| 0x95 | BASS_COEF_CTO_A2 | 0xAC | TREB_COEF_CTO_A2 | | |
| 0x96 | BASS_MIX | 0xAD | TREB_MIX | | |

Table 14. DACCRAM Bass/Treble Addresses

1. All B0 coefficients are set to unity (400000h) by default. All others, including M1 and M2, are 0 by default.
2. NLF coefficients (M1, M2) have a range defined as +/-8, with 1 sign bit, 3 integer bits, and 20 fraction bits. So, unity for these values is 100000h. This is as opposed to the rest of the coefficient RAM, which has a range defined as +/-2, with 1 sign bit, 1 integer bit, and 22 fraction bits.

3.5. Gain and Dynamic Range Control

The gain for a given channel is controlled by the DACVOL registers. The range of gain supported is from -95.625db to 0db in 0.375db steps.

If the result of the gain multiply step would result in overflow of the 24-bit output word width, the output is saturated at the max positive or negative value.

In addition to simple gain control, the ACS422x67 also provides sophisticated dynamic range control. The dynamic range control processing element implements limiting, dynamic range compression, and dynamic range expansion functions.

3.6. Limiter

The Limiter function will limit the output of the DSP module to the Class-D and DAC modules. If the signal is greater than 0dB it will saturate at 0dB as the final processing step within the DSP module.

There are times when the user may intentionally want the output Limiter to perform this saturation, for example +6dB of gain applied within the DSP gain control and then limited to 0dB when output to the Class-D module would result in a clipped signal driving the speaker output. This clipped signal would obviously contribute to increased distortion on the speaker output which from the user listening perception it would “sound louder”.

At other times, the system implementor may wish to protect speakers from overheating or provide hearing protection by intentionally limiting the output level before full scale is reached. A limit threshold, independent of the compressor threshold is provided for this purpose. It is expected that the limit threshold is set to a higher level than the compressor threshold.

3.7. Compressor

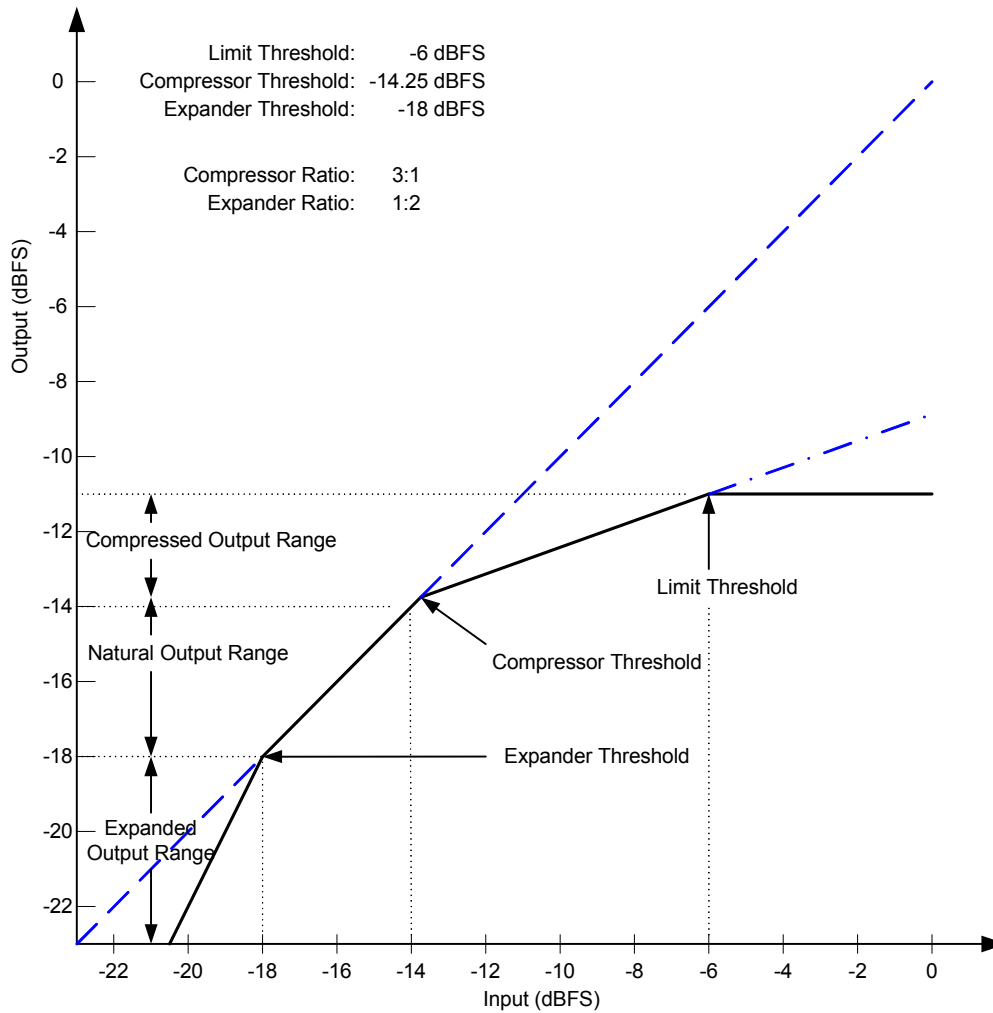

Figure 7. Gain Compressor, Output vs Input

The traditional compressor algorithm provides two functions simultaneously (depending on signal level). For higher level signals, it can provide a compression function to reduce the signal level. For lower level signals, it can provide an expansion function for either increasing dynamic range or noise gating.

The compressor monitors the signal level and, if the signal is higher than a threshold, will reduce the gain by a programmed ratio to restrict the dynamic range. Limiting is an extreme example of the compressor where, as the input signal level is increased, the gain is decreased to maintain a specific output level.

In addition to limiting the bandwidth of the compressed audio, it is common for compressed audio to also compress the dynamic range of the audio. The expansion function in the ACS422x67 can help restore the original dynamics to the audio.

The expander is a close relative of the compressor. Rather than using signal dependent gain to restrict the dynamic range, the expander uses signal dependent gain to expand the dynamic range. Thus if a signal level is below a particular threshold, the expander will reduce the gain even further to extend the dynamic range of the material.

3.7.1. Configuration

This compressor limiter provides the following configurable parameters.

- Compressor
 - Threshold – The threshold above which the compressor will reduce the dynamic range of the audio in the compression region.
 - Ratio – The ratio between the input dynamic range and the output dynamic range. For example, a ratio of 3 will reduce an input dynamic range of 9db to 3db.
 - Attack Time – The amount of time that changes in gain are smoothed over during the attack phase of the compressor.
 - Release Time – The amount of time that changes in gain are smoothed over during the release phase of the compressor.
 - Makeup gain – Used to increase the overall level of the compressed audio.
- Limiter
 - Threshold – The threshold above which the limiter will reduce the dynamic range of the audio in the compression region.
 - Target – The limit of the output level (typically set to the same as threshold).
 - Attack Time – The amount of time that changes in gain are smoothed over during the attack phase of the limiter.
 - Release Time – The amount of time that changes in gain are smoothed over during the release phase of the limiter.
- Expander
 - Threshold – The threshold below which the expander will increase the dynamic range of the audio.
 - Ratio – The ratio between the input dynamic range and the output dynamic range of the audio in the expansion range. For example a ratio of 3 will take an input dynamic range of 9db and expand it to 27db.
 - Attack Time – The amount of time that changes in gain are smoothed over during the attack phase of the expander
 - Release Time - The amount of time that changes in gain are smoothed over during the release phase of the expander.
- Two level detection algorithms
 - RMS – Use an RMS measurement for the level.
 - Peak – Use a peak measurement for the level.

3.7.2. Controlling parameters

In order to control this processing, there are a number of configurable parameters. The parameters and their ranges are:

- Compressor/limiter
 - Threshold – -40db to 0db relative to full scale.
 - Ratio – 1 to 20
 - Attack Time – typically 0 to 500ms
 - Release Time – typically 25ms to 2 seconds
 - Makeup gain – 0 to 40db

- Expander
 - Threshold – -30 to -60 dB
 - Ratio – 1 to 6
 - Attack Time – same as above
 - Release Time – same as above.
- Two level detection algorithms
 - RMS
 - Peak

3.7.3. Overview

A basic block diagram of the compressor is shown below:

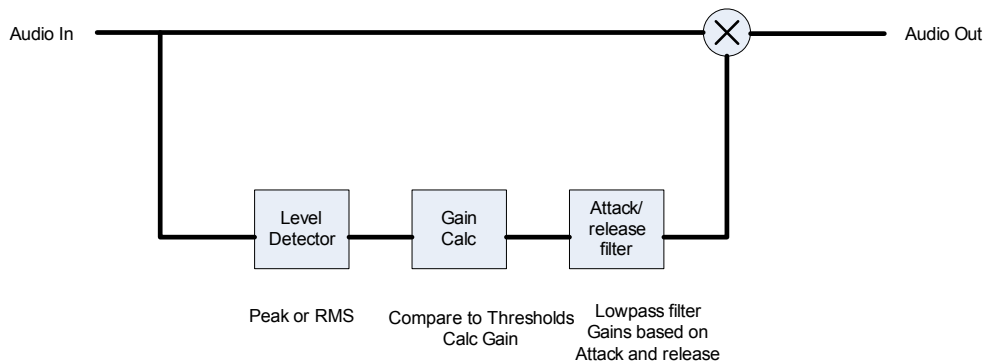

Figure 8. Compressor block diagram

As this diagram shows, there are 3 primary components of the compressor.

1. **Level Detector:** The level detector, oddly enough, detects the level of the incoming signal. Since the comp/limiter is designed to work on blocks of signals, the level detector will either find the peak value of the block of samples to be processed or the rms level of the samples within a block.
2. **Gain Calculation:** The gain calculation block is responsible for taking the output of the level detector and calculating a target gain based on that level and the compressor and expander thresholds. The compressor recalculates the target gain value every block, typically every 10ms.
 - The gain calculation operates in 3 regions:
 - Linear region – If the level is higher than the expander threshold and lower than the compression threshold, then the gain is 1.0
 - Compression region – When the level is higher than the compressor threshold, then the comp/limiter is in the compression region. The gain is a function of the compressor ratio and the signal level.
 - Expansion region – When the signal is lower than the expansion threshold, the comp/limiter is in the expansion region. In this region, the gain is a function of the signal level and the expansion ratio.
 - Compression region gain calculation: In the compression region, the gain calculation is:

$$\text{Atten}(\text{in db}) = (1 - 1/\text{ratio}) (\text{threshold}(\text{in db}) - \text{level}(\text{in db}));$$
 - For example,
 - Ratio = 4:1 compression
 - Threshold = -16db
 - Level = -4 db

The required attenuation is: 9db or a gain coefficient of 0.1259.

Translating this calculation from log space to linear yields the formula:

$$\text{Gain} = (\text{level}/\text{threshold})^{1/\text{ratio}} * (\text{threshold}/\text{level})$$

- Expansion region gain calculation: In the expansion region, the attenuation calculation is:

$$\text{Atten}(\text{in db}) = (1 - \text{ratio}) (\text{threshold} - \text{level});$$

- For example,
 - Ratio = 3:1
 - Threshold = -40db
 - Level = -44 db

The resulting attenuation required is 8db or a gain value of 0.1585.

The linear equation for calculating the gain is:

$$\text{Gain} = (\text{level}/\text{threshold})^{\text{ratio}} * (\text{threshold}/\text{level})$$

- State Transitions: In addition to calculating the new gain for the compressor, the gain calculation block will also select the filter coefficient for the attack/release filter. The rules for selecting the coefficient are as follows:

In the compression region:

- If the gain calculated is less than the last gain calculated (more compression is being applied), then the filter coefficient is the compressor attack.
- If the gain calculated is more than the last gain calculated (less compression), the filter coefficient is the compressor release.
- In the expansion region:
- If the calculated gain is less than the last gain calculated (closing expander, the filter coefficient is the expander attack.
- If the calculated gain is more than the last gain calculated, the filter coefficient is the expander release.

In the linear region:

- Modify gain until a gain of 1.0 is obtained.
- If the last non-linear state was compression, use the compressor release.
- If the last non-linear state was expansion, use the expander attack.

3. **Attack/Release filter:** In order to prevent objectionable artifacts, the gain is smoothly ramped from the current value to the new value calculated by the gain calculation block. In the PC-based comp/limiter, this is achieved using a simple tracking lowpass filter to smooth out the abrupt transitions. The calculation (using the coefficient (coeff) selected by the gain block) is:

$$\text{Filtered_gain} = \text{coeff} * \text{last_filtered_gain} + (1.0 - \text{coeff}) * \text{target_gain};$$

This creates a exponential ramp from the current gain value to the new value.

3.7.4. Limiter/Compressor Registers

- **General compressor/limiter/expander control**

| Register Address | Bit | Label | Type | Default | Description |
|---------------------|-----|-----------|------|---------|--|
| R37 (25h) CLECTL | 7:5 | RSVD | R | 0h | Reserved |
| | 4 | Lvl_Mode | RW | 0 | CLE Level Detection Mode 0 = Average 1 = Peak |
| | 3 | WindowSel | RW | 0 | Window width selection for level detection: 0 = equivalent of 512 samples of selected Base Rate (~10-16ms) 1 = equivalent of 64 samples of selected Base Rate (~1.3-2ms) |
| | 2 | Exp_en | RW | 0 | 1 = enable expander |
| | 1 | Limit_en | RW | 0 | 1 = enable limiter |
| | 0 | Comp_en | RW | 0 | 1 = enable compressor |

Table 15. CLECTL Register

- **Compressor/Limiter/Expander make-up gain**

| Register Address | Bit | Label | Type | Default | Description |
|---------------------|-----|-------------|------|---------|----------------------------|
| R38 (26h) MUGAIN | 7:5 | RSVD | R | 0h | Reserved |
| | 4:0 | CLEMUG[4:0] | RW | 0h | 0dB..46.5dB in 1.5dB steps |

Table 16. MUGAIN Register

- **Compressor Threshold**

| Register Address | Bit | Label | Type | Default | Description |
|---------------------|-----|-------------|------|---------|--|
| R39 (27h) COMPTh | 7:0 | COMPTh[7:0] | RW | 00h | FFh..00h = 0dB..95.625dB in 0.375dB steps. |

Table 17. COMPTh Register

- **Compressor ratio register**

| Register Address | Bit | Label | Type | Default | Description |
|---------------------|-----|-------------|------|---------|--|
| R40 (28h) CMPRAT | 7:5 | RSVD | R | 000 | Reserved |
| | 4:0 | CMPRAT[4:0] | RW | 00h | Compressor Ratio 00h = Reserved 01h = 1.5:1 02h..14h = 2:1..20:1 15h..1Fh = Reserved |

Table 18. CMPRAT Register

- **Compressor Attack Time Constant Register (Low)**

| Register Address | Bit | Label | Type | Default | Description |
|----------------------|-----|--------------|------|---------|--|
| R41 (29h) CATKTCL | 7:0 | CATKTCL[7:0] | RW | 00h | Low byte of the time constant used to ramp to a new gain value during a compressor attack phase. |

Table 19. CATKTCL Register

• **Compressor Attack Time Constant Register (High)**

| Register Address | Bit | Label | Type | Default | Description |
|----------------------|-----|--------------|------|---------|---|
| R42 (2Ah) CATKTCH | 7:0 | CATKTC[15:8] | RW | 00h | High byte of the time constant used to ramp to a new gain value during a compressor attack phase. |

Table 20. CATKTCH Register

• **Compressor Release Time Constant Register (Low)**

| Register Address | Bit | Label | Type | Default | Description |
|----------------------|-----|-------------|------|---------|---|
| R43 (2Bh) CRELTCL | 7:0 | CRELTC[7:0] | RW | 00h | Low byte of the time constant used to ramp to a new gain value during a compressor release phase. |

Table 21. CRELTCL Register

• **Compressor Release Time Constant Register (High)**

| Register Address | Bit | Label | Type | Default | Description |
|----------------------|-----|--------------|------|---------|--|
| R44 (2Ch) CRELTCH | 7:0 | CRELTC[15:8] | RW | 00h | High byte of the time constant used to ramp to a new gain value during a compressor release phase. |

Table 22. CRELTCH Register

• **Limiter Threshold Register**

| Register Address | Bit | Label | Type | Default | Description |
|--------------------|-----|------------|------|---------|--|
| R45 (2Dh) LIMTH | 7:0 | LIMTH[7:0] | RW | 00h | FFh..00h = 0dB..95.625dB in 0.375dB steps. |

Table 23. LIMTH Register

• **Limiter Target Register**

| Register Address | Bit | Label | Type | Default | Description |
|---------------------|-----|-------------|------|---------|--|
| R46 (2Eh) LIMTGT | 7:0 | LIMTGT[7:0] | RW | 00h | FFh..00h = 0dB..95.625dB in 0.375dB steps. |

Table 24. LIMTGT Register

• **Limiter Attack Time Constant Register (Low)**

| Register Address | Bit | Label | Type | Default | Description |
|----------------------|-----|-------------|------|---------|---|
| R47 (2Fh) LATKTCL | 7:0 | LATKTC[7:0] | RW | 00h | Low byte of the time constant used to ramp to a new gain value during a limiter attack phase. |

Table 25. LATKTCL Register

• **Limiter Attack Time Constant Register (High)**

| Register Address | Bit | Label | Type | Default | Description |
|----------------------|-----|--------------|------|---------|--|
| R48 (30h) LATKTCH | 7:0 | LATKTC[15:8] | RW | 00h | High byte of the time constant used to ramp to a new gain value during a limiter attack phase. |

Table 26. LATKTCH Register

• **Limiter Release Time Constant Register (Low)**

| Register Address | Bit | Label | Type | Default | Description |
|----------------------|-----|-------------|------|---------|--|
| R49 (31h) LRELTCL | 7:0 | LRELTC[7:0] | RW | 00h | Low byte of the time constant used to ramp to a new gain value during a limiter release phase. |

Table 27. LRELTCL Register

• **Limiter Release Time Constant Register (High)**

| Register Address | Bit | Label | Type | Default | Description |
|----------------------|-----|---------------|------|---------|---|
| R50 (32h) LRELTCH | 7:0 | LRELTCH[15:8] | RW | 00h | High byte of the time constant used to ramp to a new gain value during a limiter release phase. |

Table 28. LRELTCH Register

3.7.5. Expander Registers

• **Expander Threshold Register**

| Register Address | Bit | Label | Type | Default | Description |
|--------------------|-----|------------|------|---------|--|
| R51 (33h) EXPTH | 7:0 | EXPTH[7:0] | RW | 00h | Expander threshold: 0..95.625dB in 0.375dB steps |

Table 29. EXPTH Register

• **Expander Ratio Register**

| Register Address | Bit | Label | Type | Default | Description |
|---------------------|-----|-------------|------|---------|--|
| R52 (34h) EXPRAT | 7:3 | RSVD | R | 00h | Reserved |
| | | EXPRAT[2:0] | RW | 000 | Expander Ratio 0h..1h = Reserved 2h..7h = 1:2..1:7 |

Table 30. EXPRAT Register

• **Expander Attack Time Constant Register (Low)**

| Register Address | Bit | Label | Type | Default | Description |
|----------------------|-----|--------------|------|---------|---|
| R53 (35h) XATKTCL | 7:0 | XATKTCL[7:0] | RW | 00h | Low byte of the time constant used to ramp to a new gain value during an expander attack phase. |

Table 31. XATKTCL Register

• **Expander Attack Time Constant Register (High)**

| Register Address | Bit | Label | Type | Default | Description |
|----------------------|-----|---------------|------|---------|--|
| R54 (36h) XATKTCH | 7:0 | XATKTCH[15:8] | RW | 00h | High byte of the time constant used to ramp to a new gain value during an expander attack phase. |

Table 32. XATKTCH Register

• **Expander Release Time Constant Register (Low)**

| Register Address | Bit | Label | Type | Default | Description |
|----------------------|-----|--------------|------|---------|--|
| R55 (37h) XRELTCL | 7:0 | XRELTCL[7:0] | RW | 0 | Low byte of the time constant used to ramp to a new gain value during an expander release phase. |

Table 33. XRELTCL Register

• **Expander Release Time Constant Register (High)**

| Register Address | Bit | Label | Type | Default | Description |
|----------------------|-----|---------------|------|---------|---|
| R56 (38h) XRELTCH | 7:0 | XRELTCH[15:8] | RW | 0 | High byte of the time constant used to ramp to a new gain value during an expander release phase. |

Table 34. XRELTCH Register

3.8. Output Effects

The ACS422x67 offers Bass enhancement, Treble enhancement, Stereo Depth enhancement. The output effects processing is outlined in the following sections.

| Register Address | Bit | Label | Type | Default | Description |
|--------------------|-----|---------|------|---------|--|
| R57 (39h) FXCTL | 7:5 | RSVD | R | 000 | Reserved |
| | 4 | 3DEN | RW | 0 | 3D Enhancement Enable 0 = Disabled 1 = Enabled |
| | 3 | TEEN | RW | 0 | Treble Enhancement Enable 0 = Disabled 1 = Enabled |
| | 2 | TNLFBYP | RW | 0 | Treble Non-linear Function Bypass: 0 = Enabled 1 = Bypassed |
| | 1 | BEEN | RW | 0 | Bass Enhancement Enable 0 = Disabled 1 = Enabled |
| | 0 | BNLFBYP | RW | 0 | Bass Non-linear Function Bypass: 0 = Enabled 1 = Bypassed |

Table 35. FX Control Register

3.9. Stereo Depth (3-D) Enhancement

The ACS422x67 has a digital depth enhancement option to artificially increase the separation between the left and right channels, by enabling the attenuation of the content common to both channels. The amount of attenuation is programmable within a range. The input is prescaled (fixed) before summation to prevent saturation.

The 3-D enhancement algorithm is a tried and true algorithm that uses two principles.

1. If the material common to the two channels is removed, then the speakers will sound more 3-D.
2. If the material for the opposite channel is presented to the current channel inverted, it will tend to cancel any material from the opposite channel on the current ear. For example, if the material from the right is presented to the left ear inverted, it will cancel some of the material from the right ear that is leaking into the right ear.

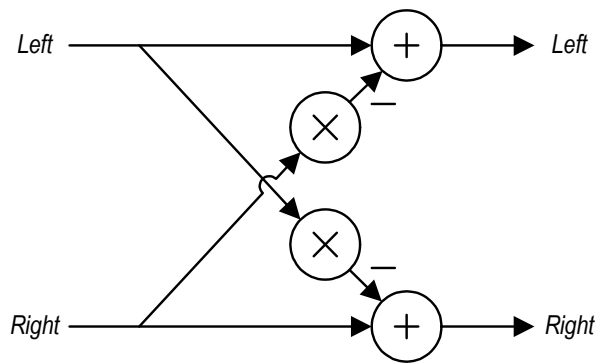

Figure 9. 3-D Channel Inversion

Note: 3D_Mix specifies the amount of the common signal that is subtracted from the left and right channels. This number is a fractional amount between 0 and 1. For proper operation, this value is typically negative.

3.10. Psychoacoustic Bass Enhancement

One of the primary audio quality issues with small speaker systems is their inability to reproduce significant amounts of energy in the bass region (below 200Hz). While there is no magic mechanism to make a speaker reproduce frequencies that it is not capable of, there are mechanisms for fooling the ear into thinking that the bass material is being heard.

The psychoacoustic bass processor relies on a psychoacoustic principle called “missing fundamental”. If the human ear hears a proper series of harmonics for a particular bass note, the listener will hear the fundamental of that series, even if it is not present.

3.11. Psychoacoustic Treble Enhancement

One of the mechanisms used to limit the bit rate for compressed audio is to first remove high frequency information before compression. When these files like low bit rate MP3 are decompressed, this can lead to dull sounding audio. The TSI treble enhancement replaces these lost high frequencies.

The psychoacoustic treble processor relies on a psychoacoustic principle called “missing fundamental”. If the human ear hears a proper series of harmonics for a particular treble note, the listener will hear the fundamental of that series, even if it is not present.

3.12. Mute and De-Emphasis

The ACS422x67 has a Soft Mute function, which is used to gradually attenuate the digital signal volume to zero. The gain returns to its previous setting if the soft mute is removed. At startup, the codec is muted by default; to enable audio play, the mute bit must be cleared to 0.

After the equalization filters, de-emphasis may be performed on the audio data to compensate for pre-emphasis that may be included in the audio stream. De-emphasis filtering is only available for 48kHz, 44.1kHz, and 32kHz sample rates.

3.13. Mono Operation and Phase Inversion

Normal stereo operation converts left and right channel digital audio data to analog in separate DACs. However, it is also possible to have the same signal (left or right) appear on both analog output channels by disabling one channel; alternately, there is a mono-mix mode that mixes the two channels digitally before converting to analog using only one DAC. In this mode, the other DAC is switched off, and the resulting mixed stream signal can appear on both analog output channels. The DAC output defaults to non-inverted. Setting DACPOLL and DACPOLR bits will invert the DAC output phase on the left and right channels.

3.13.1. DAC Control Register

| Register Address | Bit | Label | Type | Default | Description |
|----------------------|-----|-------------------|------|---------|---|
| R24 (18h) CNVRTR1 | 7 | DACPOLR | RW | 0 | Invert DAC Right signal |
| | 6 | DACPOLL | RW | 0 | Invert DAC Left signal |
| | 5:4 | DMONOMIX [1:0] | RW | 00 | DAC mono mix 00: stereo 01: mono ((L/2)+(R/2)) into DACL, '0' into DACR 10: mono ((L/2)+(R/2)) into DACR, '0' into DACL 11: mono ((L/2)+(R/2)) into DACL and DACR |
| | 3 | DACMU | RW | 1 | Digital Soft Mute 1 = mute 0 = no mute (signal active) |
| | 2 | DEEMP | RW | 0 | De-emphasis Enable 1 = De-emphasis Enabled 0 = No De-emphasis |
| | 1:0 | RSVD | R | 00 | Reserved |

Table 36. CNVRTR1 Register

3.14. Analog Outputs

3.14.1. Headphone Output

The HPOut pins can drive a 16Ω or 32Ω headphone or alternately drive a line output. The signal volume of the headphone amplifier can be independently adjusted under software control by writing to HPVOL_L and HPVOL_R. Setting the volume to 0000000 will mute the output driver; the output remains at ground, so that no click noise is produced when muting or un-muting.

Gains above 0dB run the risk of clipping large signals.

To minimize artifacts such as clicks and zipper noise, the headphone and BTL outputs feature a volume fade function that smoothly changes volume from the current value to the target value.

3.14.1.1. Headphone Volume Control Registers

| Register Address | Bit | Label | Type | Default | Description |
|--------------------|-----|------------------|------|------------------|---|
| R2 (00h) HPVOLL | 7 | RSVD | R | 0 | Reserved |
| | 6:0 | HPVOL_L [6:0] | RW | 1110111 (0dB) | Left Headphone Volume 1111111 = +6dB 1111110 = +5.25dB ... 1110111 = 0dB ... 0000001 = -88.5dB 0000000 = Analog mute Note: If HPVOLU is set, this setting will take effect after the next write to the Right Input Volume register. |
| R3 (01h) HPVOLR | 7 | RSVD | R | 0 | Reserved |
| | 6:0 | HPVOL_R [6:0] | RW | 1110111 | Right Headphone Volume 1111111 = +6dB 1111110 = +5.25dB ... 1110111 = 0dB ... 0000001 = -88.5dB 0000000 = Analog mute |

Table 37. HPVOL L/R Registers

3.14.2. Speaker Outputs

The LSPKOut (L+, L-) and RSPKOut (R+, R-) pins are controlled similarly, but independently of, the headphone output pins. They are intended to drive an 8 ohm or 4 ohm speaker pair.

3.14.2.1. Speaker Volume Control Registers

| Register Address | Bit | Label | Type | Default | Description |
|--------------------|-----|-------------------|------|------------------|---|
| R2 (2h) SPKVOLL | 7 | RSVD | R | 0 | Reserved |
| | 6:0 | SPKVOL_L [6:0] | RW | 1101111 (0dB) | Left Speaker Volume 1111111 = +12dB 1111110 = +11.25dB ... 1101111 = 0dB ... 0001000 to 0000001 = -77.25dB 0000000 = Mute Note: If SPKVOLU is set, this setting will take effect after the next write to the Right Input Volume register. |
| R3 (3h) SPKVOLR | 7 | RSVD | R | 0 | Reserved |
| | 6:0 | SPKVOL_R [6:0] | RW | 1101111 (0dB) | Right Speaker Volume 1111111 = +12dB 1111110 = +11.25dB ... 1101111 = 0dB ... 0001000 to 0000001 = -77.25dB 0000000 = Mute |

Table 38. SPKVOL L/R Registers

3.14.3. DDX™ Class D Audio Processing

The DDX™ Class D PWM Controller performs the following signal processing:

- Feedback filters are applied to shape any noise. The filters move noise from audible frequencies to frequencies above the audio range.
- The PWM block converts the data streams to tri-state PWM signals and sends them to the power stages.
- Finally, the Class-D controller block adjusts the output volume to provide constant output power across supply voltage.

The power stages boost the signals to higher levels, sufficient to drive speakers at a comfortable listening level.

3.14.3.1. Constant Output Power Mode

In normal operation the BTL amplifier is rated at 0.5W (full scale digital with 6dB BTL gain) into an 8 ohm load at 3.6V but will vary from about 0.38W to about 1.2W across a 3.1V to 5.5V supply range. However, when constant output power mode is enabled, the full scale output is held constant from 3.1V to 5.5V.

The BTL amplifier in ACS422x67 will continuously adjust to power supply changes to ensure that the full scale output power remains constant. This is not an automatic level control. Rather, this function prevents sudden volume changes when switching between battery and line power. Please note,

when in this mode the amplifier efficiency may be reduced and decreases with higher supply voltages and lower target values.

A simple 5-bit ADC is used to monitor PVDD. As PVDD raises or lowers, the analog circuit will send a 5-bit code to the digital section that will average and then calculate a gain adjustment. The BTL audio signal will be multiplied by this gain value (in addition to the user volume controls).

The user will select a target value for the circuit. The constant output function will calculate a gain adjustment that will provide approximately the same full scale output voltage as provided when PVDD causes the same code value. So, if the target is 9 then a PVDD voltage of about 3.7V would generate a code value of 9 and a full scale output power of about 630mW into 8 ohms. If PVDD should rise to 4V, generating a code of 13, then the constant output power circuit would reduce the gain by 0.75dB (4 codes * 0.1875dB) to keep the full scale output at the target level.

The circuit may be configured to add gain, attenuation, or both to maintain the full-scale output level. If the needed adjustment falls outside of the range of the circuit (only attenuation is enabled and gain is needed, for example) then the circuit will apply as much correction as it is able. Through the use of gain, attenuation, and target values, different behaviors may be implemented:

- Attenuation only, target set to mimic a low supply voltage - Constant output level across battery state with constant quality (THD/SNR)
- Attenuation only, target set to mimic a moderate supply voltage - Output limiting to an approximate power level. Level will decrease at lower supply voltages but won't increase beyond a specific point.
- Gain only, target at or near max - Output will remain relatively constant but distortion will increase as PVDD is lowered. This mimics the behavior of common class-AB amplifiers.
- Gain and attenuation - Output remains at a level below the maximum possible at the highest supply voltage and above the theoretical full scale at minimum supply. Full scale PCM input clips when the supply voltage is low but won't become too loud when the supply voltage is high.

In addition to maintaining a constant output level, PVDD may be monitored for a large, sudden, change. If the High Delta function is enabled and PVDD changes more than 4 code steps since the last cycle, the output will be rapidly reduced then gradually increased to the target level.

When using this circuit, please take note of the following:

- The full scale output power may be limited by the supply voltage.
- Full scale output power is affected by other gain controls in the output path including the EQ and compressor/limiter.
- The Constant Output Power function is intended to help maintain a constant output level, not an exact output level. The output level for a specific target may vary part to part. If limiting is required for safety or other reasons, be conservative and set the target well below the maximum allowable level.
- Noise on the PVDD supply may cause erratic behavior. Use the recommended supply decoupling caps and verify that the power supply can support the peak currents demanded by a class-D amplifier.

Constant Output Power error (dB) relative to a target of 8 for an ideal part and the output error if left uncorrected across a 3.1 to 5.5V supply range.

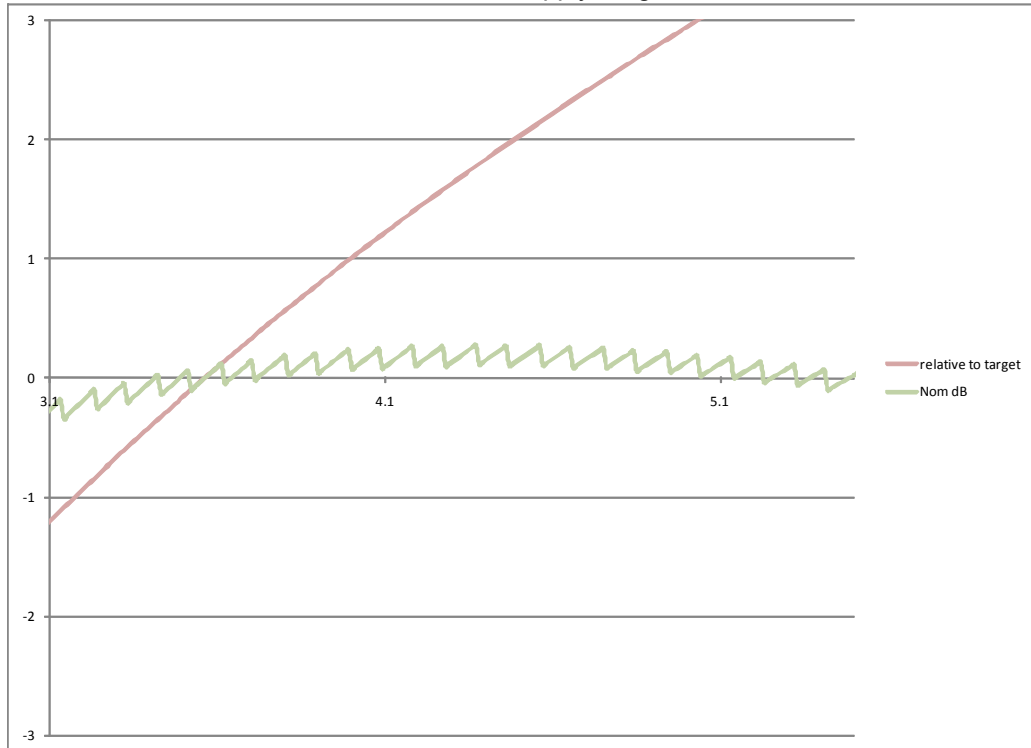

Figure 10. Constant Output Power Error

Constant Output Power for nominal and high/low reference across a 3.1 to 5.5V supply range. (Uncorrected power shown for reference) A target of 8 roughly corresponds to 0.5W at 3.6V into 8 ohms.

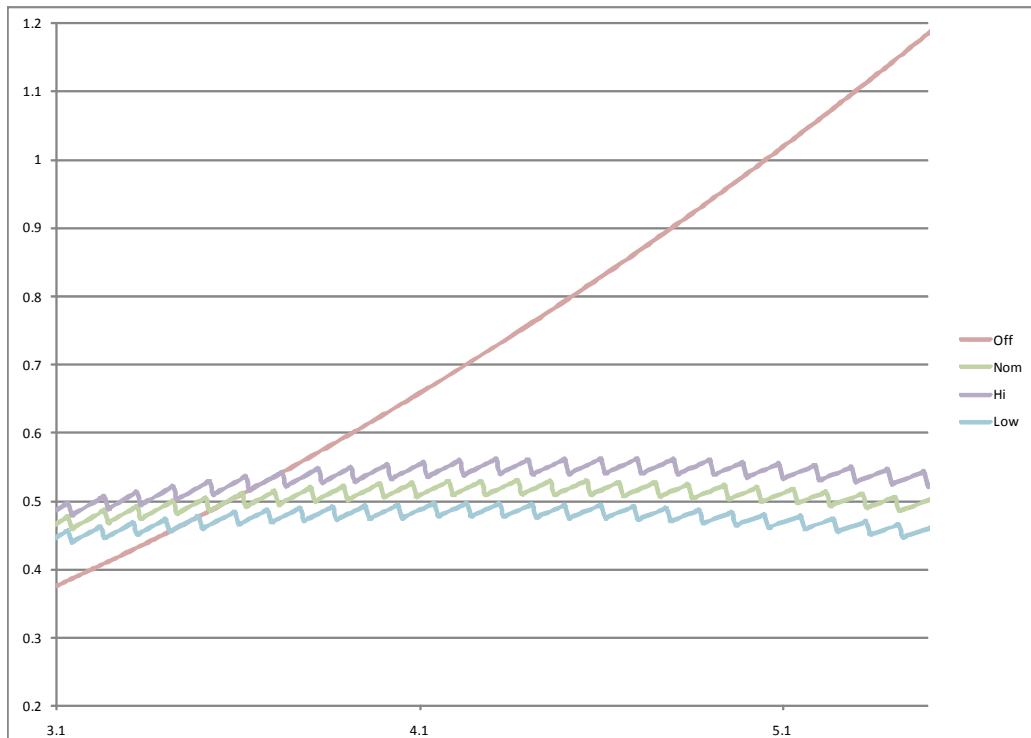

Figure 11. Constant Output Power nominal and high/low

3.14.3.2. Under Voltage Lock Out

When the PVDD supply becomes low, the BTL amplifier may be disabled to help prevent undesirable amplifier operation (overheat) or system level problems (battery under-voltage.)

The same circuit that monitors the PVDD supply to help maintain a constant output power is used to monitor the PVDD supply for a critical under-voltage situation. If the sense circuit consistently returns a 0 code then the PVDD supply is less than the minimum required for proper operation. To prevent accidental shutdown due to a noisy supply at the minimum operating range, the output of the PVDD sense circuit will be averaged for at least 200ms.

3.14.3.3. Registers

• Constant Output Power 1

| Register Address | Bit | Label | Type | Default | Description |
|--------------------------------------|-----|----------------|------|---------|--|
| R34 (22h) Constant Output Power 1 | 7 | COPAtten | RW | 0 | 1 = Constant Output Power function will use attenuate the BTL output if the PVDD sense circuit returns a code higher than the target value. |
| | 6 | COPGain | RW | 0 | 1 = Constant Output Power function will use attenuate the BTL output if the PVDD sense circuit returns a code higher than the target value. |
| | 5 | HDeltaEn | RW | 0 | 1 = If the PVDD code value has changed more than 4 counts since the last gain adjustment, the output will be reduced rapidly then slowly returned to the target level. |
| | 4:0 | COPTarget[4:0] | RW | 8h | 5-bit target for the Constant Output Power function. |

Table 39. Constant Output Power 1 Register

• Constant Output Power 2

| Register Address | Bit | Label | Type | Default | Description |
|--------------------------------------|-----|----------------|------|---------|--|
| R35 (23h) Constant Output Power 2 | 7 | RSVD | R | 0 | Reserved |
| | 6 | RSVD | R | 0 | Reserved |
| | 5:3 | AvgLength[2:0] | RW | 000 | Number of sense cycles to average: 000 = 1 001 = 2 010 = 4 011 = 8 100 = 16 101 = 32 110 = 64 111 = 128 |
| | 2:0 | MonRate[2:0] | RW | 100 | Rate the PVDD supply is monitored: 000 = 0.0625ms 001 = 0.125ms 010 = 0.25ms 011 = 0.5ms 100 = 1ms 101 = 2ms 110 = 4ms 111 = 8ms |

Table 40. Constant Output Power 2 Register

• Constant Output Power 3

| Register Address | Bit | Label | Type | Default | Description |
|---------------------------------------|-----|-----------|------|---------|--|
| R137 (89h) Constant Output Power 3 | 7 | HighDelta | R | 0 | 1 = A high delta situation has been detected (positive code change > 4) and the constant output power function is adjusting. |
| | 6 | RSVD | R | 0 | 1 = Constant Output Power function will use attenuate the BTL output if the PVDD sense circuit returns a code higher than the target value. |
| | 5:0 | COPAdj | R | 0h | Amount that the Constant Output Power function is adjusting the signal gain. Value is 2s compliment with each step equal to 0.1875dB. The approximate range is +/- 6dB |

Table 41. Constant Output Power 3 Register

• Configuration Register

| Register Address | Bit | Label | Type | Default | Description |
|----------------------|-----|-----------|------|---------|---|
| R31 (1Fh) CONFIG0 | 7:6 | ASDM[1:0] | RW | 10h | ADC Modulator Rate |
| | 5:4 | DSDM[1:0] | RW | 10h | DAC Modulator Rate |
| | 3:2 | RSVD | R | 0h | Reserved for future use. |
| | 1 | dc_bypass | RW | 0 | 1 = bypass DC removal filter (WARNING DC content can damage speakers) |
| | 0 | RSVD | R | 0 | Reserved |

Table 42. CONFIG0 Register

• PWM Control 0 Register

| Register Address | Bit | Label | Type | Default | Description |
|-------------------|-----|---------------|------|---------|--|
| R66 (42h) PWM0 | 7:5 | SCTO | RW | 11 | Class-D Short Circuit Detect Time-out 00 = 10uS 01 = 100uS 10 = 500uS 11 = 100mS |
| | 5 | UVLO | RW | 1 | Under Voltage Lock Out 1 = BTL output disabled if PVDD sense circuit returns code 0 |
| | 4 | roundup | RW | 1 | 1 = roundup, 0 = truncate for quantizer |
| | 3 | bfclr | RW | 0 | 1 = disable binomial filter |
| | 2 | fourthorder | RW | 1 | 1 = 4th order binomial filter; 0 = 3rd order |
| | 1 | add3_sel | RW | 0 | 1 = 24-bit Noise Shaper output (pre-quantizer) 0 = 8/9/10-bit quantizer output |
| | 0 | quantizer_sel | RW | 0 | |

Table 43. PWM0 Register

• PWM Control 1 Register

| Register Address | Bit | Label | Type | Default | Description |
|-------------------|-----|--------------|------|---------|---|
| R67 (43h) PWM1 | 7 | RSVD | R | 0 | Reserved |
| | 6:2 | dithpos[4:0] | RW | 0 | Dither position, where dither inserted after NS. 0,1,2 = dither bits 2:0 4 = dither bits 3:1 5 = dither bits 4:1 19 = dither bits 19:17 |
| | 1 | dith_range | RW | 0 | 1 = dither -1 to +1, 0 = -3 to +3 |
| | 0 | dithclr | RW | 0 | 1 = disable dither |

Table 44. PWM1 Register

• PWM Control 2 Register

| Register Address | Bit | Label | Type | Default | Description |
|-------------------|-----|-------------|------|---------|--|
| R68 (44h) PWM2 | 7:2 | dvalue[5:0] | RW | 18h | dvalue constant field |
| | 1 | pwm_outflip | RW | 0 | 1 = swap pwm a/b output pair for all channels The control lines to the power stage are swapped inverting the output signal. |
| | 0 | pwm_outmode | RW | 1 | 1 = tristate, 0 = binary |

Table 45. PWM2 Register

• PWM Control 3 Register

| Register Address | Bit | Label | Type | Default | Description |
|-------------------|-----|--------------|------|---------|---|
| R69 (45h) PWM3 | 7:6 | outctrl[1:0] | RW | 00 | pwm output muxing 0 = normal 1 = swap 0/1 2 = ch0 on both 3 = ch1 on both |
| | 5:0 | cvalue[5:0] | RW | 0Ah | tristate constant field, must be even and not 0 |

Table 46. PWM3 Register

3.15. Other Output Capabilities

Each audio analog output can be separately enabled. Disabling outputs serves to reduce power consumption, and is the default state of the device.

3.15.1. Audio Output Control

See Power management section. The output enable bits are also power management bits and the outputs will be turned off when disabled.

| Register Address | Bit | Label | Type | Default | Description |
|--------------------------------------|-----|---------|------|---------|-------------------------------|
| R27 (1Bh) Power Management (2) | 7 | D2S | RW | 0 | Analog in D2S AMP Enable |
| | 6 | HPOutL | RW | 0 | Left Headphone Output Enable |
| | 5 | HPOutR | RW | 0 | Right Headphone Output Enable |
| | 4 | SPKOutL | RW | 0 | Left Speaker Output Enable |
| | 3 | SPKOutR | RW | 0 | Right Speaker Output Enable |
| | 2 | RSVD | RW | 0 | |
| | 1 | RSVD | RW | 0 | |
| | 0 | VREF | RW | 1 | Voltage reference |

Note: A value of "1" indicates the output is enabled; a value of '0' disables the output.

Table 47. Power Management 2 Register

3.15.2. Headphone Switch

The HPDETECT pin is used to detect connection of a headphone. When headphone insertion is detected, the codec can automatically disable the speaker outputs and enable the headphone outputs. Control bits determine the meaning and polarity of the input.

In addition to enabling and disabling outputs, the EQ may also be controlled using the HP_DET pin. The 2 EQ filters may be configured so that one EQ is active when the Headphone output is active and the other EQ is active when the Speaker output is active (independent HP and Speaker EQ). One EQ may be enabled only when the Speaker is active and the other EQ may be on when either of the outputs are active (Speaker compensation and USER EQ) or other combinations are possible. Note that the EQ coefficients must be programmed and the EQs must be enabled using their control registers. The HP_DET logic can only disable the EQ filters.

3.15.2.1. Headphone Switch Register

| Register Address | Bit | Label | Type | Default | Description |
|--|-----|------------|------|---------|---|
| R29 (1Ch) Additional Control (CTL) | 7 | HPSWEN | RW | 0 | Headphone Switch Enable 0: Headphone switch disabled 1: Headphone switch enabled |
| | 6 | HPSWPOL | RW | 0 | Headphone Switch Polarity 0: HPDETECT high = headphone 1: HPDETECT high = speaker |
| | 5:4 | EQ2SW[1:0] | RW | 00 | EQ2 behavior due to speaker/headphone output state |
| | 3:2 | EQ1SW[1:0] | RW | 00 | EQ1 behavior due to speaker/headphone output state |
| | 1 | TSDEN | RW | 0 | Thermal Shutdown Enable (See section 7.9) 0: thermal shutdown disabled 1: thermal shutdown enabled |
| | 0 | TOEN | RW | 0 | Zero Cross Time-out Enable 0: Time-out Disabled 1: Time-out Enabled - volumes updated if no zero cross event has occurred before time-out |

Table 48. Additional Control Register

3.15.3. Headphone Operation

| HPSWEN | HPSWPOL | HP_DET Pin state | HPOut ¹ | SPKOut ² | Headphone Enabled | Speaker Enabled |
|--------|---------|---------------------|--------------------|---------------------|----------------------|--------------------|
| 0 | X | X | 0 | 0 | no | no |
| 0 | X | X | 0 | 1 | no | yes |
| 0 | X | X | 1 | 0 | yes | no |
| 0 | X | X | 1 | 1 | yes | yes |
| 1 | 0 | 0 | X | 0 | no | no |
| 1 | 0 | 0 | X | 1 | no | yes |
| 1 | 0 | 1 | 0 | X | no | no |
| 1 | 0 | 1 | 1 | X | yes | no |
| 1 | 1 | 0 | 0 | X | no | no |
| 1 | 1 | 0 | 1 | X | yes | no |
| 1 | 1 | 1 | X | 0 | no | no |
| 1 | 1 | 1 | X | 1 | no | yes |

Table 49. Headphone Operation

- 1.HPOut = Logical OR of the HPL and HPR enable (power state) bits
- 2.SPKOut = Logical OR of the SPKL and SPKR enable (power state) bits

3.15.4. EQ Operation

| EQnSW1 | EQnSW0 | EQ Behavior ¹ |
|--------|--------|---|
| 0 | 0 | EQ is not disabled due to Headphone/Speaker logic |
| 0 | 1 | EQ is disabled when Headphone output is active |
| 1 | 0 | EQ is disabled when Speaker output is active |
| 1 | 1 | EQ is disabled when Headphone AND Speaker output are active |

Table 50. EQ Operation

- 1.EQ must be enabled. EQ behavior is dependent on HP_DET and Output power state programming.

3.16. Thermal Shutdown

To avoid overpowering and overheating the codec when the amplifier outputs are driving large currents, the ACS422x67 incorporates a thermal protection circuit. If enabled, and the device temperature reaches approximately 150°C, the speaker and headphone amplifier outputs will be disabled. Once the device cools, the outputs will be automatically re-enabled.

3.16.1. Algorithm description:

There are 2 trip points, “high” and “low”. High indicates a critical overheat requiring a reduction in volume to avoid damage to the part. Low is set for a slightly lower temperature point, indicating that the current level is safe but that increased volume would result in a critical overheat condition.

Normally, the overheat bits are polled every 8ms but may be polled at 4ms, 8ms, 16ms, or 32ms by adjusting the Poll value. Reductions in volume will be allowed to happen at the Poll rate. Increases in volume are programmable to happen every 1, 2, 4, or 8 Poll cycles and in steps of 0.75dB to 6dB. This allows a full scale volume increase in a range of 10s of milliseconds to 10s of seconds.

When both overheat bits are 0, the volume is allowed to increment by the IncStep size, unless the volume has already reached the maximum value allowed. Any subsequent increment will be held off until the programmed number of polling cycles have occurred.

When the low overheat bit is 1 and the high overheat bit is 0, this indicates that the volume is currently at a safe point but the temperature is higher than desired and incrementing the volume may cause severe overheating. The volume is held at the current value.

When the high overheat bit is 1, damage could occur, so the volume setting will be immediately reduced by the Decrement Step value. As the overheat bits are re-polled, this volume reduction will continue until the high overheat bit drops to 0 or the volume value reaches the minimum setting. If the high overheat bit remains 1 even at the minimum setting, then the mute control bit will be asserted. If the high overheat bit persists even after mute, then the BTL amp will be powered down.

3.16.2. Thermal Trip Points.

The high and low trip points can be adjusted to suit the needs of a particular system implementation. There is a “shift” value (TripShift) which sets the low trip point, and there is a “split” value (TripSplit) that sets how many degrees above the low trip point the high trip point is.

By default:

TripShift = 2 (140 degrees C)
TripSplit = 0 (15 degrees C)

Therefore:

High Trip Point = 155°C.
Low Trip Point = 140°C.

3.16.3. Instant Cut Mode

This mode can be used to make our algorithm react faster to reduce thermal output but will cause more pronounced volume changes. If enabled:

- Only the high overheat is used, the low overheat is ignored.
- Whenever polled, if the high overheat is 1, then the volume setting will immediately be set to 0h.
- Conversely, if the high overheat is 0, the volume setting will immediately be set to the MaxVol value.
- Both volume clear and volume set events occur at the polling rate.

During this mode, the algorithm still possesses the ability to mute and then power down the BTL amp if the high overheat continues to be 1.

This mode is disabled by default.

3.16.4. Short Circuit Protection

To avoid damage to the outputs if a short circuit condition should occur, both the headphone and BTL amplifiers implement short circuit protection circuits. The headphone output amplifier will detect the load current and limit its output if in an over current state. The BTL amplifier will sense a short to PVDD, ground, or between its +/- outputs and disable its output if a short is detected. After a brief time, the amplifier will turn on again. If a short circuit condition is still present, the amplifier will disable itself again.

3.16.5. Thermal Shutdown Registers

The thermal shutdown circuit is enabled using the Additional Control Register, see Table 51.

3.16.5.1. Headphone Switch Register

| Register Address | Bit | Label | Type | Default | Description |
|--|-----|------------|------|---------|---|
| R29 (1Ch) Additional Control (CTL) | 7 | HPSWEN | RW | 0 | Headphone Switch Enable 0: Headphone switch disabled 1: Headphone switch enabled |
| | 6 | HPSWPOL | RW | 0 | Headphone Switch Polarity 0: HPDETECT high = headphone 1: HPDETECT high = speaker |
| | 5:4 | EQ2SW[1:0] | RW | 00 | EQ2 behavior due to speaker/headphone output state |
| | 3:2 | EQ1SW[1:0] | RW | 00 | EQ1 behavior due to speaker/headphone output state |
| | 1 | TSDEN | RW | 0 | Thermal Shutdown Enable (See section 7.9) 0: thermal shutdown disabled 1: thermal shutdown enabled |
| | 0 | TOEN | RW | 0 | Zero Cross Time-out Enable 0: Time-out Disabled 1: Time-out Enabled - volumes updated if no zero cross event has occurred before time-out |

Table 51. Additional Control Register

3.16.5.2. Temp Sensor Control/Status Register

| Register Address | Bit | Label | Type | Default | Description |
|---|-----|----------------|------|---------|--|
| R29 (1Dh) Temp Sensor Control/Status (THERMTS) | 7 | TripHighStat | R | 0 | Temp sensor high trip point status 0 = Normal Operation 1 = Over Temp Condition |
| | 6 | TripLowStat | R | 0 | Temp sensor low trip point status 0 = Normal Operation 1 = Over Temp Condition |
| | 5:4 | TripSplit[1:0] | RW | 0h | Temp sensor "split" setting. Determines how many degrees above the low trip point the high trip is set: 0h = 15 Degrees C 1h = 30 Degrees C 2h = 45 Degrees C 3h = 60 Degrees C. |
| | 3:2 | TripShift[1:0] | RW | 2h | Temp sensor "shift" setting. Determines the low trip temperature: 0h = 110 Degrees C 1h = 125 Degrees C 2h = 140 Degrees C 3h = 155 Degrees C. |
| | 1:0 | Poll[1:0] | RW | 1h | Temp sensor polling interval 0h = 4ms 1h = 8ms 2h = 16ms 3h = 32ms |

Table 52. THERMTS Register

3.16.5.3. Temp Sensor Status Register

| Register Address | Bit | Label | Type | Default | Description |
|---|-----|---------------|------|---------|--|
| R30 (1Eh) Speaker Thermal Algorithm Control (THERMSPKR1) | 7 | ForcePwd | RW | 1 | Force powerdown enable for the speaker thermal algorithm: 0 = Speaker will remain powered up even if the temp sensor continues to report an overheat condition at minimum volume (mute) 1 = Speaker will be powered down if the temp sensor reports an overheat at the minimum volume (mute) |
| | 6 | InstCutMode | RW | 0 | Instant Cut Mode 0 = Both temp sensor status bits used to smoothly adjust the volume. 1 = Only the high temp sensor status bit will be used to set the volume. volume will be set to the full volume or mute (IncStep and DecStep are ignored.) |
| | 5:4 | IncRatio[1:0] | RW | 0h | Increment interval ratio. Determines the ratio between the speaker volume increment interval and the speaker volume decrement interval (increment rate is equal to or slower than decrement rate): 0h = 1:1 1h = 2:1 2h = 4:1 3h = 8:1 |
| | 3:2 | IncStep[1:0] | RW | 0h | Increment step size for the speaker thermal control algorithm (occurs at the temp sensor polling rate X the increment interval ratio.) 0h = 0.75dB 1h = 1.5dB 2h = 3.0dB 3h = 6.0dB |
| | 1:0 | DecStep[1:0] | RW | 1h | Decrement step size for the speaker thermal control algorithm (occurs at the temp sensor polling rate.) 0h = 3dB 1h = 6dB 2h = 12dB 3h = 24dB |

Table 53. THERMTSPKR1 Register

| Register Address | Bit | Label | Type | Default | Description |
|---|-----|----------------|------|---------|--|
| R136 (88h) Speaker Thermal Algorithm Status (THERMSPKR2) | 7 | ForcePwdStatus | R | 0 | 0: Speaker not powered down due to thermal algorithm 1: Speaker has been powered down because overtemp condition was present even though the speaker was muted. |
| | 6:0 | VolStatus[6:0] | R | 08 | Current speaker volume value. If no overheat is being reported by the temperature sensor, this value should be equal to the greater of the left or right speaker volume setting. |

Table 54. THERMTSPKR2 Register

4. INPUT AUDIO PROCESSING

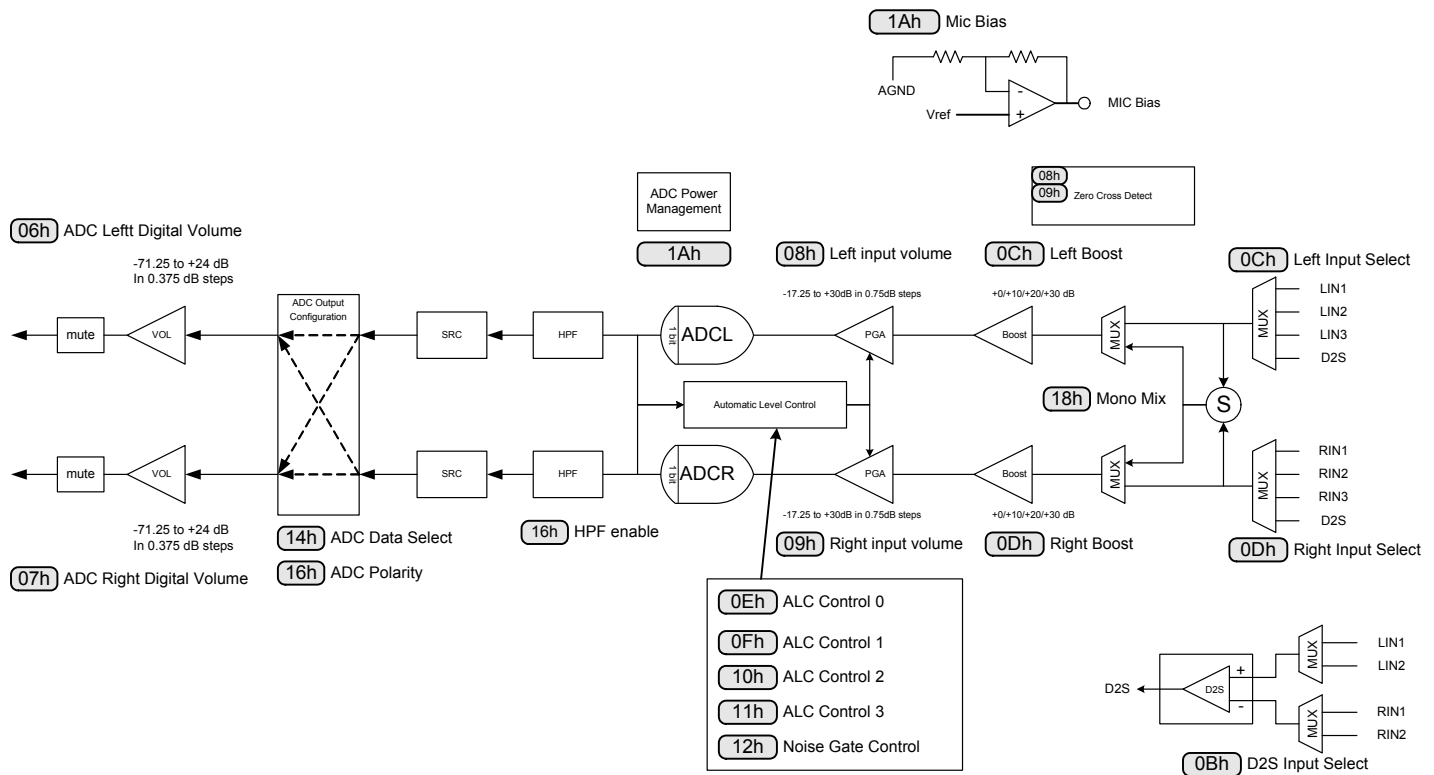

Figure 12. Input Audio Processing

4.1. Analog Inputs

The ACS422x67 provides multiple high impedance, low capacitance AC-coupled analog inputs with an input signal path to the stereo ADCs. Prior to the ADC, there is a multiplexor that allows the system to select which input is in use. Following the mux, there is a programmable gain amplifier and also an optional microphone gain boost. The gain of the PGA can be controlled either by the system, or by the on-chip level control function. The stereo record path can also operate with the two channels mixed to mono either in the analog or digital domains.

Signal inputs are biased internally to AVSS but AC coupling capacitors are required when connecting microphones (due to the 2.5V microphone bias) or when offsets would cause unacceptable “zipper noise” or pops when changing PGA or boost gain settings. To avoid audio artifacts, the line inputs are kept biased to analog ground when they are muted or the device is placed into standby mode.

4.1.1. Input Registers

| Register Address | Bit | Label | Type | Default | Description |
|---|-----|----------|------|---------|---|
| R12 (0Ch) ADC Signal Path Control Left (INSELL) | 7:6 | INSEL_L | RW | 00 | Left Channel Input Select 00 = LINPUT1 01 = LINPUT2 10 = LINPUT3 11 = D2S |
| | 5:4 | MICBST_L | RW | 00 | Left Channel Microphone Gain Boost 00 = Boost off (bypassed) 01 = 10dB boost 10 = 20dB boost 11 = 30dB boost |
| | 3:0 | RSVD | R | 0000 | Reserved |
| R13 (0Dh) ADC Signal Path Control Right (INSELR) | 7:6 | INSEL_R | RW | 00 | Right Channel Input Select 00 = RINPUT1 01 = RINPUT2 10 = RINPUT3 11 = D2S |
| | 5:4 | MICBST_R | RW | 00 | Right Channel Microphone Gain Boost 00 = Boost off (bypassed) 01 = 10dB boost 10 = 20dB boost 11 = 30dB boost |
| | 3:0 | RSVD | R | 0000 | Reserved |

Table 55. Input Software Control Register

4.2. Mono Mixing and Output Configuration

The stereo ADC can operate as a stereo or mono device, or the two channels can be mixed to mono. Mixing can occur either in the input path (analog, before ADC) or after the ADC. MONOMIX determines whether to mix to mono, and where.

For analog mono mix, either the left or right channel ADC can be used for the audio stream. The other ADC may be powered off to conserve power. A differential input amplifier may be selected as a mono source to either ADC input. This D2S amplifier can select either Input 1 or Input 2 using the DS bit.

The system also has the flexibility to select the data output. ADCDSEL configures the interface, assigning the source of the left and right ADC independently.

4.2.1. ADC Registers

4.2.1.1. ADC D2S Input Mode Register

| Register Address | Bit | Label | Type | Default | Description |
|---|-----|-------|------|---------|---|
| R11 (0Bh) ADC Input mode (INMODE) | 7:1 | RSVD | R | 0h | Reserved |
| | 0 | DS | RW | 0 | Differential Input Select 0: LIN1 - RIN1 1: LIN2 - RIN2 |

Table 56. INMODE Register

4.2.1.2. ADC Mono, Filter and Inversion Register

| Register Address | Bit | Label | Type | Default | Description |
|---------------------------------------|-----|-------------------|------|---------|--|
| R22 (16h) ADC Control (CNVRTR0) | 7 | ADCPOLR | RW | 0 | ADC Right Channel Polarity 0 = normal 1 = inverted |
| | 6 | ADCPOLL | RW | 0 | ADC Left Channel Polarity 0 = normal 1 = inverted |
| | 5:4 | AMONOMIX [1:0] | RW | 00 | ADC mono mix 00: Stereo 01: Analog Mono Mix (using left ADC) 10: Analog Mono Mix (using right ADC) 11: Digital Mono Mix (ADCL/2 + ADCR/2 on both Left and Right ADC outputs) |
| | 3 | ADCMU | RW | 1 | 1 = Mute ADC |
| | 2 | HPOR | RW | 0 | High Pass Offset Result 0 = discard offset when HPF disabled 1 = store and use last calculated offset when HPF disabled |
| | 1 | ADCHPDR | RW | 0 | ADC High Pass Filter Disable (Right) |
| | 0 | ADCHPDL | RW | 0 | ADC High Pass Filter Disable (Left) |

Table 57. CNVRTR0 Register

4.2.1.3. ADC Data Output Configuration Register

| Register Address | Bit | Label | Type | Default | Description |
|---|-----|--------------|------|---------|--|
| R20 (14h) Audio Interface Control 2 (AIC2) | 7:6 | DACDSEL[1:0] | RW | 00 | 00: left DAC = left I2S data; right DAC = right I2S data 01: left DAC = left I2S data; right DAC = left I2S data 10: left DAC = right I2S data; right DAC = right I2S data 11: left DAC = right I2S data; right DAC = left I2S data |
| | 5:4 | ADCSEL[1:0] | RW | 00 | 00: left I2S data = left ADC; right I2S data = right ADC 01: left I2S data = left ADC; right I2S data = left ADC 10: left I2S data = right ADC; right I2S data = right ADC 11: left I2S data = right ADC; right I2S data = left ADC |
| | 3 | TRI | RW | 0 | Interface Tri-state (See Section 9.2.4) |
| | 2:0 | BLRCM | RW | 0 | Bitclock and LRClock mode (See Section 9.2.4) |

Table 58. AIC2 Register

4.3. Microphone Bias

The MICBIAS output is used to bias electric type microphones. It provides a low noise reference voltage used for an external resistor biasing network. The MICB control bit is used to enable the output.

The MICBIAS can source up to 3mA of current; therefore, the external resistors must be large enough to conform to this limit.

4.3.1. Microphone Bias Control Register

| Register Address | Bit | Label | Type | Default | Description |
|--------------------------------------|-----|-------|------|---------|---|
| R26 (1Ah) Power Management (1) | 1 | MICB | RW | 0 | Microphone Bias Enable 0 = OFF (high impedance output) 1 = ON |

Table 59. Power Management 1 Register - Mic Bias Enable

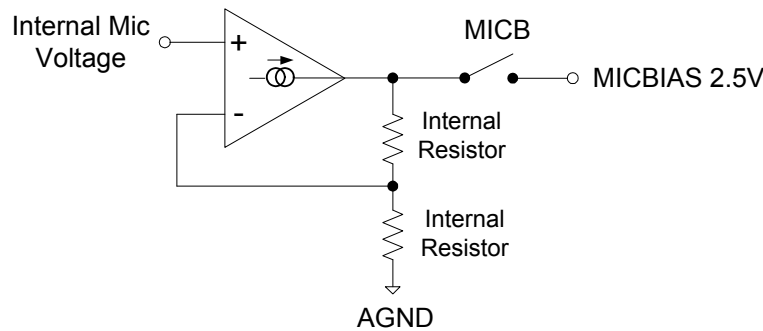

Figure 13. Mic Bias

4.4. Programmable Gain Control

The Programmable Gain Amplifier (PGA) enables the input signal level to be matched to the ADC input range. Amplifier gain is adjustable across the range +30dB to -17.25dB (using 0.75dB steps). The PGA can be controlled directly by the system software using the Input Volume Control registers (INVOLL and INVOLR), or alternately the Automatic Level Control (ALC) function can automatically control the gain. If the ALC function is used, writing to the Input Volume Control registers has no effect.

Left and right input gains are independently adjustable. By controlling the update bit (INVOLU), the left and right gain settings can be simultaneously updated. To eliminate zipper noise, LZCEN and RZCEN bits enable a zero-cross detector to insure changes only occur when the signal is at zero. A time-out for zero-cross is also provided, using TOEN in register R29 (1Dh).

Software can also mute the inputs in the analog domain.

4.4.1. Input PGA Software Control Register.

| Register Address | Bit | Label | Type | Default | Description |
|--|-----|------------------|------|-----------------|---|
| R8 (08h) Left Input Volume (INVOLL) | 7 | RSVD | RW | 0 | |
| | 6 | IZCL | RW | 0 | Left Channel Zero Cross Detector 1 = Change gain on zero cross only 0 = Change gain immediately Note: If INVOLU is set, this setting will take effect after the next write to the Right Input Volume register. |
| | 5:0 | INVOL_L [5:0] | RW | 010111 (0dB) | Left Channel Input Volume Control 111111 = +30dB 111110 = +29.25dB .. 0.75dB steps down to 000000 = -17.25dB Note: If INVOLU is set, this setting will take effect after the next write to the Right Input Volume register. |
| R9 (09h) Right Input Volume (INVOLR) | 7 | RSVD | RW | 0 | |
| | 6 | IZCR | RW | 0 | Right Channel Zero Cross Detector 1 = Change gain on zero cross only 0 = Change gain immediately |
| | 5:0 | INVOL_R [5:0] | RW | 010111 (0dB) | Right Channel Input Volume Control 111111 = +30dB 111110 = +29.25dB .. 0.75dB steps down to 000000 = -17.25dB |
| R28 (1Ch) Additional Control (CTL) | 0 | TOEN | RW | 0 | Zero Cross Time-out Enable 0: Time-out Disabled 1: Time-out Enabled - volumes updated if no zero cross event has occurred before time-out |

Table 60. INVOL L&R Registers

4.5. ADC Digital Filter

To provide the correct sampling frequency on the digital audio outputs, ADC filters perform true 24-bit signal processing and convert the raw multi-bit oversampled data from the ADC using the digital filter path illustrated below.

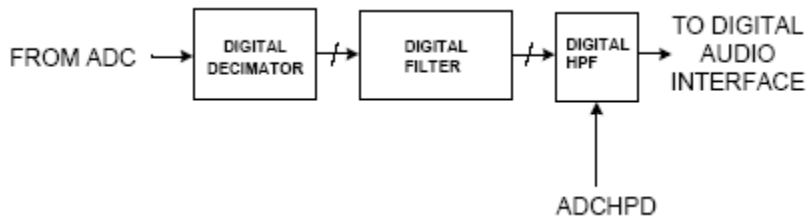

Figure 14. ADC Filter Data path

The ADC digital filters contain a software-selectable digital high pass filter. When the high-pass filter is enabled, the dc offset is continuously calculated and subtracted from the input signal. The HPOR bit enables the last calculated DC offset value to be stored when the high-pass filter is disabled; this value will then continue to be subtracted from the input signal. To provide support for calibration, the stored and subtracted value will not change unless the high-pass filter is enabled even if the DC value is changed. The high pass filter may be enabled separately for each of the left and right channels.

The output data format can be programmed by the system. This allows stereo or mono recording streams at both inputs. Software can change the polarity of the output signal.

4.5.1. ADC Signal Path Control Register

| Register Address | Bit | Label | Type | Default | Description |
|--------------------------------------|-----|-------------------|------|---------|---|
| R22 (16h) ADC Control (CNRTR0) | 7 | ADCPOLR | RW | 0 | 0 = Right polarity not inverted 1 = Right polarity inverted |
| | 6 | ADCPOLL | RW | 0 | 0 = Left polarity not inverted 1 = Left polarity inverted |
| | 5:4 | AMONOMIX [1:0] | RW | 00 | ADC mono mix 00: Stereo 01: Analog Mono Mix (using left ADC) 10: Analog Mono Mix (using right ADC) 11: Digital Mono Mix |
| | 3 | ADCMU | RW | 1 | 1 = Mute ADC |
| | 2 | HPOR | RW | 0 | High Pass Offset Result 0 = discard offset when HPF disabled 1 = store and use last calculated offset when HPF disabled |
| | 1 | ADCHPDR | RW | 0 | ADC High Pass Filter Disable (Right) |
| | 0 | ADCHPDL | RW | 0 | ADC High Pass Filter Disable (Right) |

Table 61. CNVRTR0 Register

4.5.2. ADC High Pass Filter Enable modes

| ADCHPDR | ADCHPDL | High Pass Mode |
|---------|---------|---|
| 0 | 0 | High-pass filter enabled on left and right channels |
| 0 | 1 | High-pass filter disabled on left channel, enabled on right channel |
| 1 | 0 | High-pass filter enabled on left channel, disabled on right channel |
| 1 | 1 | High-pass filter disabled on left and right channels |

Table 62. ADC HPF Enable

4.6. Digital ADC Volume Control

The ADC volume can be controlled digitally, across a gain and attenuation range of -71.25dB to +24dB (0.375dB steps). The level of attenuation is specified by an eight-bit code 'ADCVOL_x', where 'x' is L, or R. The value "00000000" indicates mute; other values describe the number of 0.375dB steps above -71.25dB.

The ADCVOLUME bit controls the updating of digital volume control data. When ADCVOLUME is written as '0', the ADC digital volume is immediately updated with the ADCVOL_L data when the Left ADC Digital Volume register is written. When ADCVOLUME is set to '1', the ADCVOL_L data is held in an internal holding register until the Right ADC Digital Volume Register is written.

4.6.1. ADC Digital Registers

| Register Address | Bit | Label | Type | Default | Description |
|---|-----|-------------------|------|-------------------|--|
| R6 (06h) Left ADC Digital Volume | 7:0 | ADCVOL_L [7:0] | RW | 10111111 (0dB) | Left ADC Digital Volume Control 0000 0000 = Digital Mute 0000 0001 = -71.25dB 0000 0010 = -70.875dB ... 0.375dB steps up to 1111 1111 = +24dB Note: If ADCVOLU is set, this setting will take effect after the next write to the Right Input Volume register. |
| R7 (07h) Right ADC Digital Volume | 7:0 | ADCVOL_R [7:0] | RW | 10111111 (0dB) | Right ADC Digital Volume Control 0000 0000 = Digital Mute 0000 0001 = -71.25dB 0000 0010 = -70.875dB ... 0.375dB steps up to 1111 1111 = +24dB |

Table 63. L/R ADC Digital Volume Registers

4.7. Automatic Level Control (ALC)

The ACS422x67 has an automatic level control to achieve recording volume across a range of input signal levels. The device uses a digital peak detector to monitor and adjusts the PGA gain to provide a signal level at the ADC input. A range of adjustment between -6dB and -28.5dB (relative to ADC full scale) can be selected. The device provides programmable attack, hold, and decay times to smooth adjustments. The level control also features a peak limiter to prevent clipping when the ADC input exceeds a threshold. Note that if the ALC is enabled, the input volume controls are ignored.

4.7.1. ALC Operation

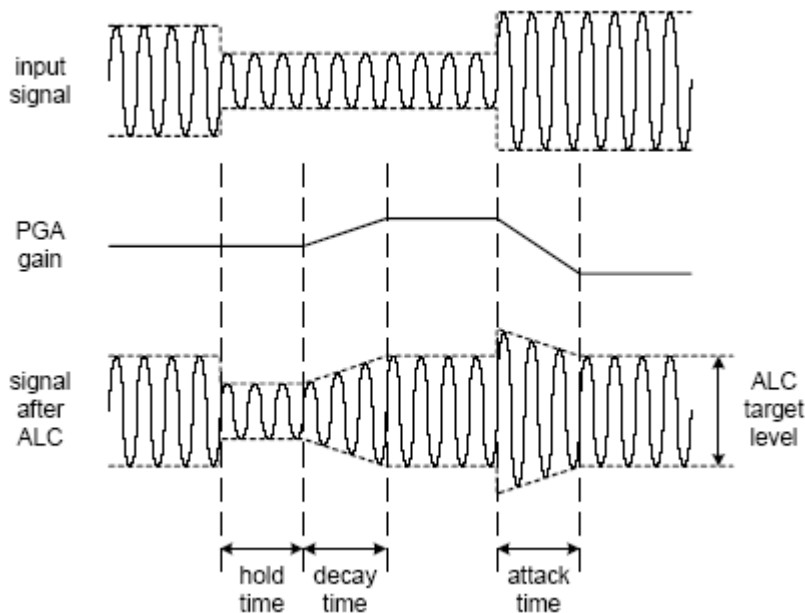

Figure 15. ALC Operation

When ALC is enabled, the recording volume target can be programmed between -6dB and -28.5dB (relative to ADC full scale). The ALC will attempt to keep the ADC input level to within +/-0.5dB of the target level. An upper limit for the PGA gain can also be imposed, using the MAXGAIN control bits.

Hold time specifies the delay between detecting a peak level being below target, and the PGA gain beginning to ramp up. It is specified as $2^n \cdot 2.67\text{mS}$, enabling a range between 0mS and over 40s.; ramp-down begins immediately if the signal level is above the target.

Decay (Gain Ramp-Up) Time is the time that it takes for the PGA to ramp up across 90% of its range. The time is $2^n \cdot 24\text{mS}$. The time required for the recording level to return to its target value therefore depends on the decay time and on the gain adjustment required.

Attack (Gain Ramp-Down) Time is the time that it takes for the PGA to ramp down across 90% of its range. Time is specified as $2^n \cdot 24\text{mS}$. The time required for the recording level to return to its target value depends on both the attack time and on the gain adjustment required.

When operating in stereo, the peak detector takes the maximum of left and right channel peak values, and both PGAs use the same gain setting, to preserve the stereo image. If the ALC function is only enabled on one channel, only one PGA is controlled by the ALC mechanism, and the other channel runs independently using the PGA gain set through the control registers.

If one ADC channel is unused, the peak detector will ignore that channel.

The ALC function can operate when the two ADC outputs are mixed to mono in the digital domain or in the analog domain.

4.7.2. ALC Registers

| Register Address | Bit | Label | Type | Default | Description |
|----------------------------|-----|---------------|------|--------------|--|
| R14 (0Eh) ALC Control 0 | 7:3 | RSVD | R | 00000 | Reserved |
| | 2 | ALC MODE | RW | 0 | 0: ALC Mode 1: Limiter mode |
| | 1:0 | ALCSEL [1:0] | RW | 00 (OFF) | ALC function select 00 = ALC off (PGA gain set by register) 01 = Right channel only 10 = Left channel only 11 = Stereo (PGA registers unused) Note: ensure that LINVOL and RINVOL settings (reg. 0 and 1) are the same before entering this mode. |
| R15 (0Fh) ALC Control 1 | 7 | RSVD | R | 0 | Reserved |
| | 6:4 | MAXGAIN [2:0] | RW | 111 (+30dB) | Set Maximum Gain of PGA 111: +30dB 110: +24dB ...(-6dB steps) 001: -6dB 000: -12dB |
| | 3:0 | ALCL [3:0] | RW | 1011 (-12dB) | ALC target – sets signal level at ADC input 0000 = -28.5dB fs 0001 = -27.0dB fs ... (1.5dB steps) 1110 = -7.5dB fs 1111 = -6dB fs |
| R16 (10h) ALC Control 2 | 7 | RSVD | RW | 0 | |
| | 6:4 | MINGAIN | RW | 000 | Sets the minimum gain of the PGA 000 = -17.25db 001 = -11.25 ... 110 = +18.75dB 111 = +24.75db where each value represents a 6dB step. |
| | 3:0 | HLD [3:0] | RW | 0000 (0ms) | ALC hold time before gain is increased. 0000 = 0ms 0001 = 2.67ms 0010 = 5.33ms ... (time doubles with every step) 1111 = 43.691s |
| R17 (11h) ALC Control 3 | 7:4 | DCY [3:0] | RW | 0011 (192ms) | ALC decay (gain ramp-up) time 0000 = 24ms 0001 = 48ms 0010 = 96ms ... (time doubles with every step) 1010 or higher = 24.58s |
| | 3:0 | ATK [3:0] | RW | 0010 (24ms) | ALC attack (gain ramp-down) time 0000 = 6ms 0001 = 12ms 0010 = 24ms ... (time doubles with every step) 1010 or higher = 6.14s |

Table 64. ALC Control Registers

4.7.3. Peak Limiter

To prevent clipping, the ALC circuit also includes a limiter function. If the ADC input signal exceeds 87.5% of full scale (-1.16dB), the PGA gain is ramped down at the maximum attack rate, until the signal level falls below 87.5% of full scale. This function is automatically enabled whenever the ALC is enabled.

4.7.4. Input Threshold

To avoid hissing during quiet periods, the ACS422x67 has an input threshold noise gate function that compares the signal level at the inputs to a noise gate threshold. Below the threshold, the programmable gain can be held, or the ADC output can be muted. The threshold can be adjusted in increments of 1.5dB.

The noise gate activates when the signal-level at the input pin is less than the Noise Gate Threshold (NGTH) setting.

The ADC output can be muted. Alternatively, the PGA gain can be held.

The threshold is adjusted in 1.5dB steps. The noise gate only works in conjunction with the ALC, and always operates on the same channel(s) as the ALC.

4.7.4.1. Noise Gate Control Register

| Register Address | Bit | Label | Type | Default | Description |
|---|-----|---------------|------|---------|---|
| R12 (12h) Noise Gate Control (NGATE) | 7:3 | NGTH [4:0] | RW | 00000 | Noise gate threshold (compared to ADC full-scale range) 00000 -76.5dBfs 00001 -75dBfs ... 1.5 dB steps 11110 -31.5dBfs 11111 -30dBfs |
| | 2:1 | NGG [1:0] | RW | 00 | Noise gate type X0 = PGA gain held 01 = mute ADC output 11 = reserved (do not use this setting) |
| | 0 | NGAT | RW | 0 | Noise gate function enable 1 = enable 0 = disable |

Table 65. NGATE Register

4.8. Digital Microphone Support

Line Input 3 may be an analog line (mic) or digital microphone input depending on the part option.

The digital microphone interface permits connection of a digital microphone(s) to the CODEC via the DMIC_DAT, and DMIC_CLK 2-pin interface. DMIC_DAT is an input that carries individual channels of digital microphone data to the ADC. In the event that a single microphone is used, the data is ported to both ADC channels. This mode is selected using a control bit and the left time slot is copied to the ADC left and right inputs.

The DMIC_CLK output is synchronous to the internal master (DSP) clock and is adjustable in 4 steps. Each step provides a clock that is a multiple of the chosen ADC base rate and modulator rate. The default frequency is 320/3 times the ADC base rate for 32KHz, and 80 times the base rate for 44.1KHz and 48KHz base rates.

| SDM Rate | DMRate [1:0] | Base Rate | DSPCLK | DMIC_CLK divisor | DMIC_CLK |
|----------|--------------|------------|------------|------------------|--------------|
| Full | 00 | 32 KHz | 40.960 MHz | 12 | 3.413333 MHz |
| | | 44.1 KHz | 56.448 MHz | 16 | 3.528 MHz |
| | | 48 KHz | 61.440 MHz | 16 | 3.84 MHz |
| | 01 | 32 KHz | 40.960 MHz | 16 | 2.56 Mhz |
| | | 44.1 KHz | 56.448 MHz | 20 | 2.8224 MHz |
| | | 48 KHz | 61.440 MHz | 20 | 3.072 MHz |
| | 10 | 32 KHz | 40.960 MHz | 20 | 2.048 Mhz |
| | | 44.1 KHz | 56.448 MHz | 24 | 2.352 MHz |
| | | 48 KHz | 61.440 MHz | 24 | 2.56 MHz |
| 11 | 32 KHz | 40.960 MHz | 24 | 1.706667 Mhz | |
| | 44.1 KHz | 56.448 MHz | 32 | 1.764 MHz | |
| | 48 KHz | 61.440 MHz | 32 | 1.92 MHz | |
| Half | 00 | 32 KHz | 40.960 MHz | 16 | 2.56 MHz |
| | | 44.1 KHz | 56.448 MHz | 16 | 3.528 MHz |
| | | 48 KHz | 61.440 MHz | 16 | 3.84 MHz |
| | 01 | 32 KHz | 40.960 MHz | 24 | 1.706667 MHz |
| | | 44.1 KHz | 56.448 MHz | 24 | 2.352 MHz |
| | | 48 KHz | 61.440 MHz | 24 | 2.56 MHz |
| | 10 | 32 KHz | 40.960 MHz | 32 | 1.28 MHz |
| | | 44.1 KHz | 56.448 MHz | 32 | 1.764 MHz |
| | | 48 KHz | 61.440 MHz | 32 | 1.92 MHz |
| 11 | 32 KHz | 40.960 MHz | 40 | 1.024 MHz | |
| | 44.1 KHz | 56.448 MHz | 40 | 1.4112 MHz | |
| | 48 KHz | 61.440 MHz | 40 | 1.536 MHz | |

Table 66. DMIC Clock

The two DMIC data inputs are shown connected to the ADCs through the same multiplexors as the analog ports. Although the internal implementation is different between the analog ports and the digital microphones, the functionality is the same. In most cases, the default values for the DMIC clock rate and data sample phase will be appropriate and an audio driver will be able to configure and use the digital microphones exactly like an analog microphone.

If the ADC path is powered down, the DMIC_CLK output will be driven low to place the DMIC element into a low power state. (Many digital microphones will enter a low power state if the clock input is held at a DC level or toggled at a slow rate.)

ACS422x67
LOW-POWER, HIGH-FIDELITY, INTEGRATED CODEC

The codec supports the following digital microphone configurations:

| Digital Mics | Data Sample | Notes |
|--------------|-------------|--|
| 0 | N/A | No Digital Microphones |
| 1 | Single Edge | When using a microphone that supports multiplexed operation (2-mics can share a common data line), configure the microphone for "Left" and select mono operation. "Left" D-mic data is used for ADC left and right channels. |
| 2 | Double Edge | External logic required to support sampling on a single Digital Mic pin channel on rising edge and second Digital Mic right channel on falling edge of DMIC_CLK for those digital microphones that don't support alternative clock edge (multiplexed output) capability. |

Table 67. Valid Digital Mic Configurations

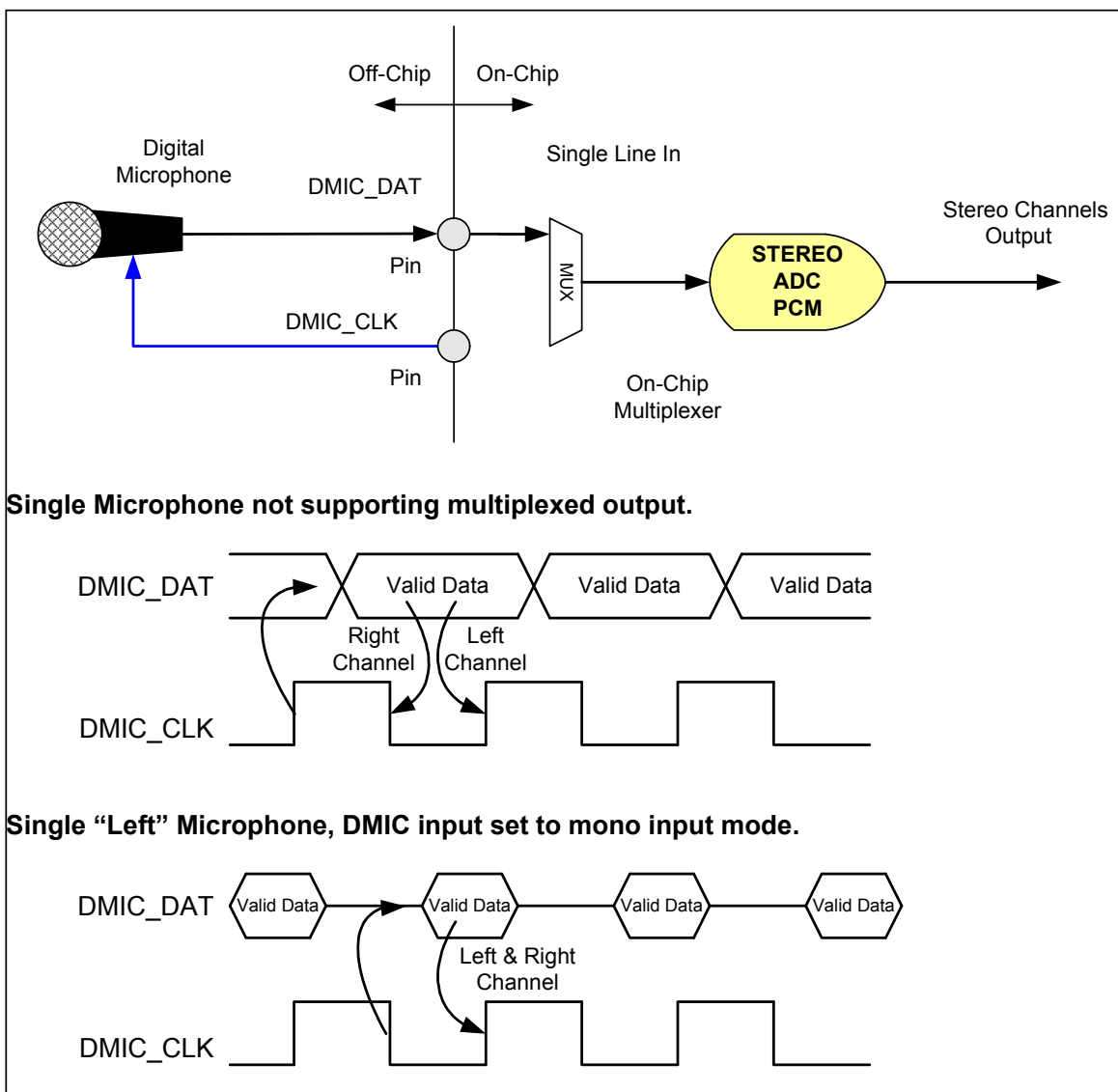

Figure 16. Single Digital Microphone (data is ported to both left and right channels)

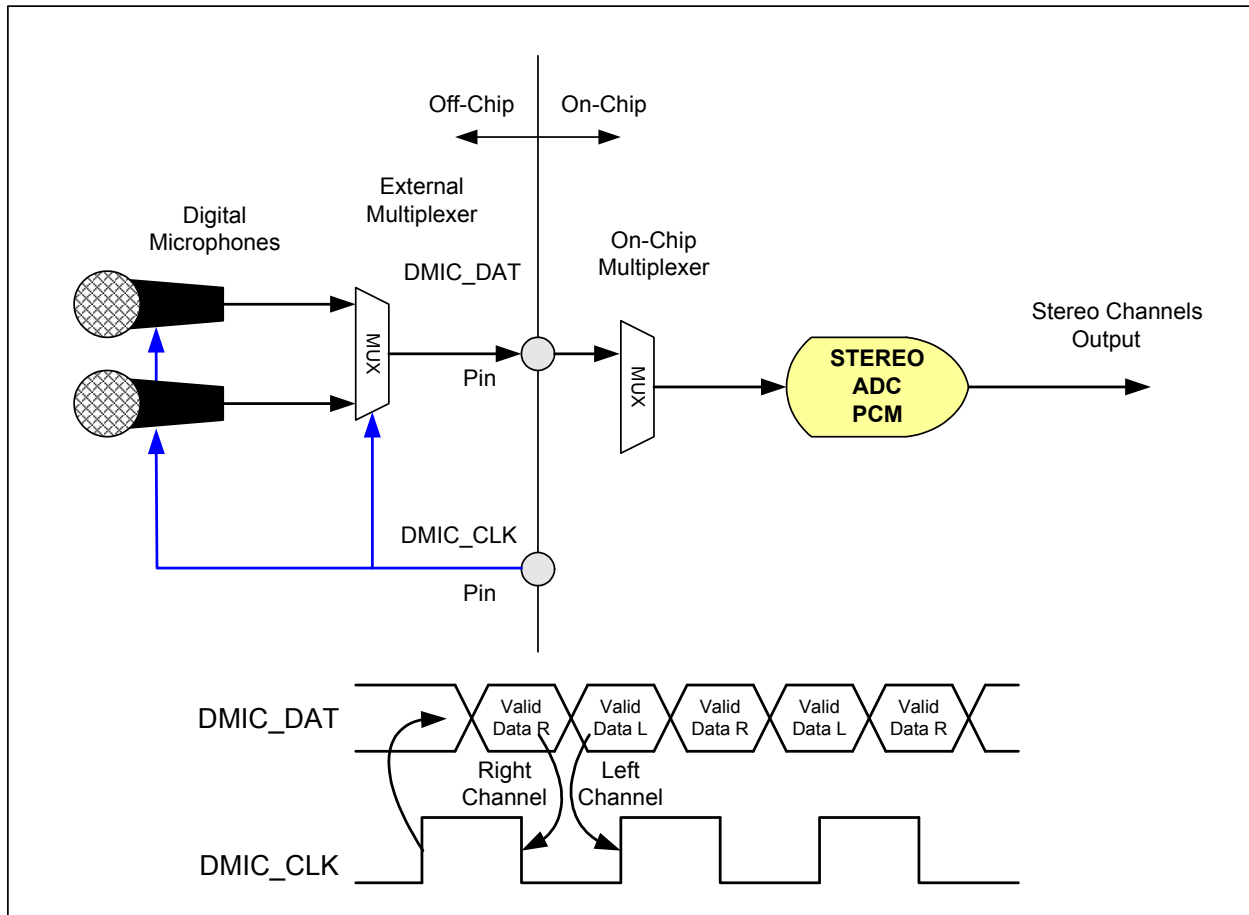

Figure 17. Stereo Digital Microphone Configuration

4.8.1. DMIC Register

| Register Address | Bit | Label | Type | Default | Description |
|---|-----|-------------|------|---------|--|
| R36 (24h) D-Mic Control (DMICCTL) | 7 | DMicEn | RW | 0 | Digital Microphone Enable 0 = DMIC interface is disabled (DMIC_CLK low, DMIC muted) 1 = DMIC interface is enabled |
| | 6:5 | RSVD | R | 00 | Reserved |
| | 4 | DMono | RW | 0 | 0 = stereo operation, 1 = mono operation (left channel duplicated on right) |
| | 3:2 | DMPAdj[1:0] | RW | 00 | Selects when the D-Mic data is latched relative to the DMIC_CLK. 00 = Left data rising edge / right data falling edge 01 = Left data center of high / right data center of low 10 = Left data falling edge / right data rising edge 11 = Left data center of low / right data center of high |
| | 1:0 | DMRate[1:0] | RW | 00 | Selects the DMIC clock rate: See table in text |

Table 68. DMICCTL Register

5. DIGITAL AUDIO AND CONTROL INTERFACES

5.1. Data Interface

For digital audio data, the ACS422x67 uses five pins to input and output digital audio data.

- ADCDOUT: ADC data output
- ADCLRCK: ADC data alignment clock
- ADCBCLK: Bit clock, for synchronization
- DACDIN: DAC data input
- DACLRCK: DAC data alignment clock
- DACBCLK: Bit clock, for synchronization

The clock signals ADCBCLK, ADCLRCK, DACBCLK, and DACLRCK are outputs when the ACS422x67 operates as a master; they are inputs when it is a slave. Three different data formats are supported:

- Left justified
- Right justified
- I²S

All of these modes are MSB first.

5.2. Master and Slave Mode Operation

The ACS422x67 can be used as either a master or slave device, selected by the MS Bit. When operating as a master, the ACS422x67 generates ADCBCLK, ADCLRCLK, DACBCLK and DACLRCLK and controls sequencing of the data transfer the data pins. In slave mode, the ACS422x67 provides data aligned to clocks it receives.

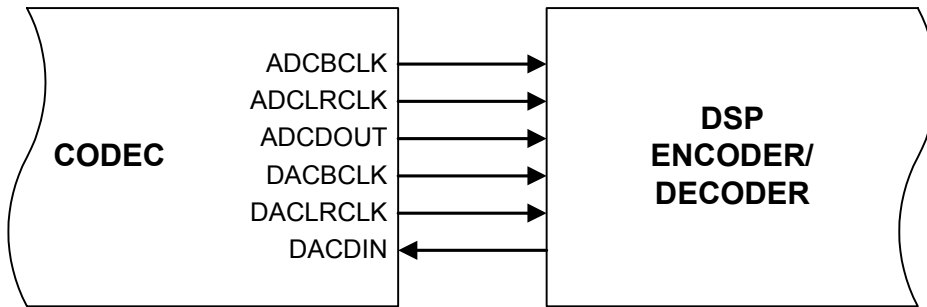

Figure 17. Master mode

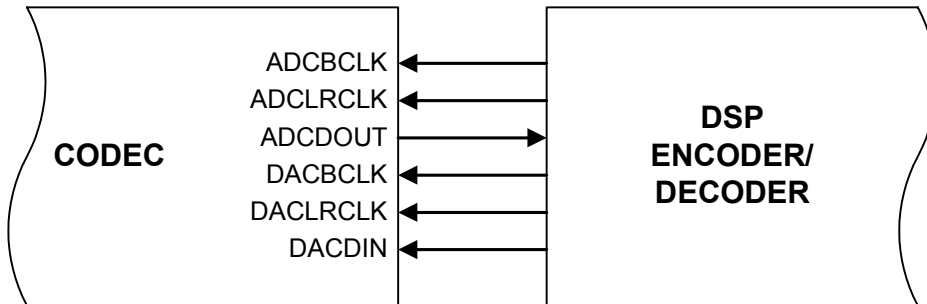

Figure 18. Slave mode

5.3. Audio Data Formats

The ACS422x67 supports 3 common audio interface formats and programmable clocking that provides broad compatibility with DSPs, Consumer Audio and Video SOCs, FPGAs, handset chipsets, and many other products.

In all modes, depending on word length, BCLK frequency and sample rate, there may be unused BCLK cycles before each LRCLK transition. If the converter word length is smaller than the number of clocks per sample in the frame then the DAC will ignore (truncate) the extra bits while the ADC will zero pad the output data. If the converter word length chosen is larger than the number of clocks available per sample in the frame, the ADC data will be truncated to fit the frame and the DAC data will be zero padded.

5.4. Left Justified Audio Interface

In Left Justified mode, the MSB is available on the first rising edge of BCLK following a LRCLK transition. The other bits are then transmitted in order. The LRCLK signal is high when left channel data is present and low when right channel data is present.

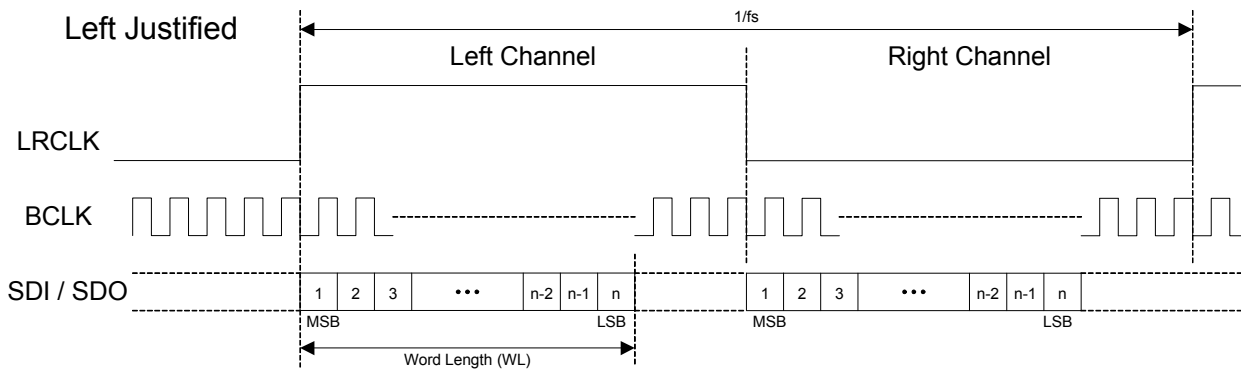

Figure 19. Left Justified Audio Interface (assuming n-bit word length)

5.5. Right Justified Audio Interface (assuming n-bit word length)

In Right Justified mode, the LSB is available on the last rising edge of BCLK before a LRCLK transition. All other bits are transmitted in order. The LRCLK signal is high when left channel data is present and low when right channel data is present.

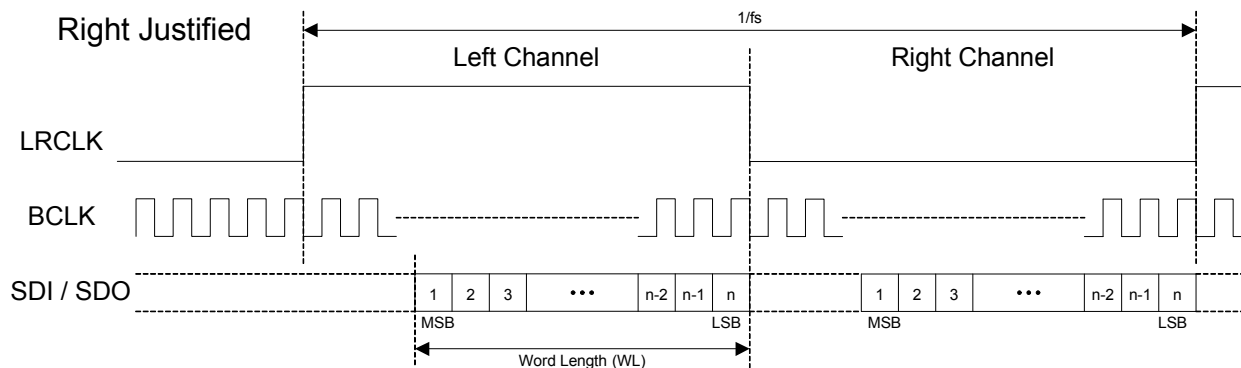

Figure 20. Right Justified Audio Interface (assuming n-bit word length)

5.6. I²S Format Audio Interface

In I²S mode, the MSB is available on the second rising edge of BCLK following a LRCLK transition. The other bits up to the LSB are then transmitted in order.

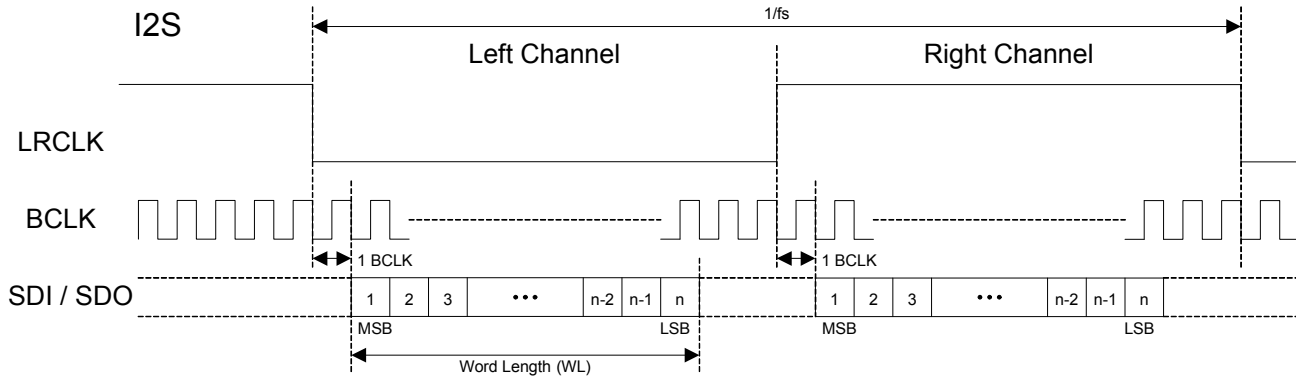

Figure 21. I²S Justified Audio Interface (assuming n-bit word length)

5.7. Data Interface Registers

5.7.1. Audio Data Format Control Register

| Register Address | Bit | Label | Type | Default | Description |
|--|-----|-------------|------|---------|--|
| R19 (13h) Digital Audio Interface Format (AIC1) | 7 | RSVD | R | 0 | Reserved |
| | 6 | BCLKINV | RW | 0 | BCLK invert bit (for master and slave modes) 0 = BCLK not inverted 1 = BCLK inverted |
| | 5 | MS | RW | 0 | Master / Slave Mode Control 1 = Enable Master Mode 0 = Enable Slave Mode |
| | 4 | LRP | RW | 0 | Right, left and I ² S modes – LRCLK polarity 1 = invert LRCLK polarity 0 = normal LRCLK polarity |
| | 3:2 | WL[1:0] | RW | 10 | Audio Data Word Length 11 = 32 bits 10 = 24 bits 01 = 20 bits 00 = 16 bits |
| | 1:0 | FORMAT[1:0] | RW | 10 | Audio Data Format Select 11 = Reserved 10 = I ² S Format 01 = Left justified 00 = Right justified |

Table 69. AIC1 Register

5.7.2. Audio Interface Output Tri-state

TRI is used to tri-state the ADCDOUT, ADCLRCK, DACLRCK, ADCBCLK, and DACBCLK pins. In Slave mode (MASTER=0) only ADCDOUT will be tri-stated since the other pins are configured as inputs. The Tri-stated pins are pulled low with an internal pull-down resistor unless that resistor is disabled.

| Register Address | Bit | Label | Type | Default | Description |
|---|-----|--------------|------|---------|---|
| R20 (14h) Audio Interface Control 2 (AIC2) | 7:6 | DACDSEL[1:0] | RW | 00 | 00: left DAC = left I2S data; right DAC = right I2S data 01: left DAC = left I2S data; right DAC = left I2S data 10: left DAC = right I2S data; right DAC = right I2S data 11: left DAC = right I2S data; right DAC = left I2S data |
| | 5:4 | ADCSEL[1:0] | RW | 00 | 00: left I2S data = left ADC; right I2S data = right ADC 01: left I2S data = left ADC; right I2S data = left ADC 10: left I2S data = right ADC; right I2S data = right ADC 11: left I2S data = right ADC; right I2S data = left ADC |
| | 3 | TRI | RW | 0 | Tri-states ADCDOUT, ADCLRCLK, DACLRCLK, ADCBCLK, and DACBCLK pins. 0 = ADCDOUT is an output, ADCLRCK, DACLRCLK, ADCBCLK, and DACBCLK are inputs (slave mode) or outputs (master mode) 1 = ADCDOUT, ADCLRCK, DACLRCLK, ADCBCLK, and DACBCLK are high impedance |
| | 2:0 | BLRCM[2:0] | RW | 000 | Bitclock and LRclock mode. See Table Below |

Table 70. AIC2 Register

5.7.3. Audio Interface Bit Clock and LR Clock configuration

Although the DAC and ADC interfaces implement separate Bit Clock and LR Clock pins, it is also possible to share one or both of the clocks.

the following restrictions must be observed when the BCLK from one path (DAC or ADC) is combined with the LRCLK from the other path (ADC or DAC) as described by the Bit Clock and LR Clock Mode Selection table below:

1. Both the DAC and ADC must be programmed for the same sample rate
2. Both the DAC and ADC must be programmed for the same number of clocks per frame
3. When in slave mode, the DAC and ADC data must be aligned relative to the provided BCLK and LRCLK (this is guaranteed in master mode)
4. The DAC and ADC must be powered down when changing the BLRCM mode
5. If sharing the BCLK from one path (DAC or ADC) and the LRCLK from the other path (ADC or DAC), shut down both the DAC and ADC before programming the sample rate and clocks per frame for either. (Again, both must match.)

5.7.4. Bit Clock and LR Clock Mode Selection

| MS | BLRCM [2:0] | MODE ¹ | DAC BCLK | ADC BCLK | DAC LRCLK | ADC LRCLK |
|----|-------------|---|---|---|---|---|
| 0 | 000 | Independent | Input for playback path | input for record path | Input for playback path | input for record path |
| 0 | 001 | Independent | Input for playback path | input for record path | Input for playback path | input for record path |
| 0 | 010 | Shared BCLK (DAC) | Input for playback and record | unused | Input for playback path | input for record path |
| 0 | 011 | Shared BCLK & LRCLK (DAC) | Input for playback and record | unused | Input for playback and record | unused |
| 0 | 100 | Shared BCLK (DAC) & LRCLK (ADC) | Input for playback and record | unused | unused | Input for playback and record |
| 0 | 101 | Shared BCLK (ADC) | unused | Input for playback and record | Input for playback path | input for record path |
| 0 | 110 | Shared BCLK (ADC) & LRCLK (DAC) | unused | Input for playback and record | Input for playback and record | unused |
| 0 | 111 | Shared BCLK & LRCLK (ADC) | unused | Input for playback and record | unused | Input for playback and record |
| 1 | 000 | Independent (off if converter off) | Output for playback path (off when DACs off) ² | Output for record path (Off when ADC off) ³ | Output for playback path (off when DACs off) | Output for record path (off when ADCs off) |
| 1 | 001 | Independent (off if all converters off) | Output for playback path (off when DACs and ADCs off) | Output for record path (off when DACs and ADCs off) | Output for playback path (off when DACs and ADCs off) | Output for record path (off when DACs and ADCs off) |
| 1 | 010 | Shared BCLK (DAC) | Output for playback and record (stays on if either DAC or ADC on) | unused (off) | Output for playback path (Off if DAC is off) | Output for record path (off when ADCs off) |
| 1 | 011 | Shared BCLK & LRCLK (DAC) | Output for playback and record (stays on if either DAC or ADC on) | unused (off) | Output for playback and record (stays on if either DAC or ADC on) | unused (off) |
| 1 | 100 | Shared BCLK(DAC)& LRCLK(ADC) | Output for playback and record (stays on if either DAC or ADC on) | unused (off) | unused (off) | Output for playback and record (stays on if either DAC or ADC on) |
| 1 | 101 | Shared BCLK (ADC) | unused (off) | Output for playback and record (stays on if either DAC or ADC on) | Output for playback path (Off if DAC is off) | Output for record path (off when ADCs off) |
| 1 | 110 | Shared BCLK(ADC)& LRCLK(DAC) | unused (off) | Output for playback and record (stays on if either DAC or ADC on) | Output for playback and record (stays on if either DAC or ADC on) | unused (off) |
| 1 | 111 | Shared BCLK & LRCLK(ADC) | unused (off) | Output for playback and record (stays on if either DAC or ADC on) | unused (off) | Output for playback and record (stays on if either DAC or ADC on) |

Table 71. Bit Clock and LR Clock Mode Selection

1. When sharing both the BCLK and LRCLK between the DAC and ADC interfaces, both the DAC and ADC must be programmed for the same rate, the same number of clocks per frame, and data must be aligned the same with respect to LRCLK. Disable all converters before changing modes.
2. DAC (playback path) is off when HPL, HPR, SPKL, and SPKR power states are off.

3.ADC (record path) is off when ADCL, and ADCR power states are off (PGA, D2S, Boost power states are not considered.)

5.7.5. ADC Output Pin State

| Tri-state (TRI) | Record Path Power State | ADC Data Out Pull-down (ADOPDD) | ADC Data Out State |
|-----------------|-------------------------|---------------------------------|--------------------|
| 0 | Off | 0 | Off, pulled-low |
| | Off | 1 | Off, floating |
| | On | NA | Active |
| 1 | NA | 0 | Off, pulled-low |
| | NA | 1 | Off, floating |

Table 72. ADC Data Output pin state

5.7.6. Audio Interface Control 3 Register

| Register Address | Bit | Label | Type | Default | Description |
|---|-----|--------|------|---------|--|
| R21 (15h) Audio Interface Control 3 (AIC3) | 7:6 | RSVD | R | 0 | Reserved |
| | 5 | ADOPDD | RW | 0 | ADCDOU Pull-Down Disable 0 = Pull-Down active when tri-stated or the ADC path is powered down. 1 = Pull-Down always disabled |
| | 4 | ALRPDD | RW | 0 | ADCLRCLK Pull-Down Disable 0 = Pull-Down active when configured as input 1 = Pull-Down always disabled |
| | 3 | ABCPDD | RW | 0 | ADCBCLK Pull-Down Disable 0 = Pull-Down active when configured as input 1 = Pull-Down always disabled |
| | 2 | DDIPDD | RW | 0 | DACDIN Pull-Down Disable 0 = Pull-Down active 1 = Pull-Down always disabled |
| | 1 | DLRPDD | RW | 0 | DACLRCLK Pull-Down Disable 0 = Pull-Down active when configured as input 1 = Pull-Down always disabled |
| | 0 | DBCPDD | RW | 0 | DACBCLK Pull-Down Disable 0 = Pull-Down active when configured as input 1 = Pull-Down always disabled |

Table 73. AIC3 Register

5.8. Bit Clock Mode

The default master mode bit clock generator automatically produces a bit clock frequency based on the sample rate and word length. When enabled by setting the appropriate BCM bits, the bit clock mode (BCM) function overrides the default master mode bit clock generator to produce the bit clock frequency shown below: Note that selecting a word length of 24-bits in Auto mode generates 64 clocks per frame (64fs)

| Register Address | Bit | Label | Type | Default | Description |
|--|-----|------------------------|------|---------|---|
| R23/R25 (17h/19h) ADC/DAC Sample Rate Control | 7:6 | ABCM[1:0] DBCM[1:0] | RW | 00 | BCLK Frequency 00 = Auto 01 = 32 x fs 10 = 40 x fs 11 = 64 x fs |

Table 74. Master Mode BCLK Frequency Control Register

The BCM mode bit clock generator produces 16, 20, or 32 bit cycles per sample.

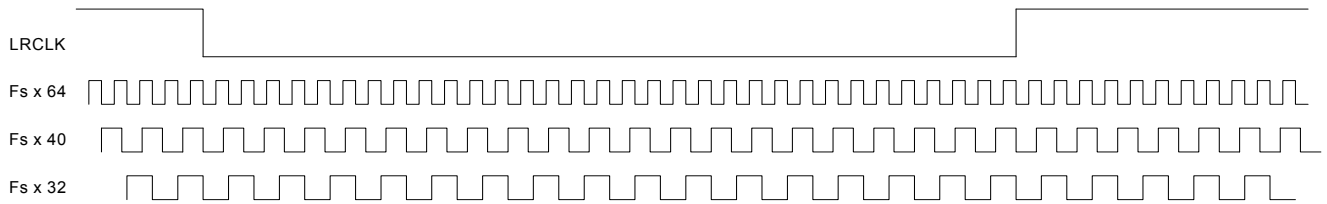

Figure 22. Bit Clock mode

Note: The clock cycles are evenly distributed throughout the frame (true multiple of LRCLK not a gated clock.)

5.9. Control Interface

The registers are accessed through a serial control interface using a multi-word protocol comprised of 8-bit words. The first 8 bits provide the device address and Read/Write flag. In a write cycle, the next 8 bits provide the register address; all subsequent words contain the data, corresponding to the 8 bits in each control register. The control interface operates using a standard 2-wire interface, as a slave device only.

5.9.1. Register Write Cycle

The controller indicates the start of data transfer with a high to low transition on SDA while SCL remains high, signalling that a device address and data will follow. All devices on the 2-wire bus respond to the start condition and shift in the next eight bits on SDIN (7-bit address + Read/Write bit, MSB first). If the device address received matches the address of the ACS422x67 and the R/W bit is '0', indicating a write, then the ACS422x67 responds by pulling SDA low on the next clock pulse (ACK); otherwise, the ACS422x67 returns to the idle condition to wait for a new start condition and valid address.

Once the ACS422x67 has acknowledged a correct device address, the controller sends the ACS422x67 register address. The ACS422x67 acknowledges the register address by pulling SDA low for one clock pulse (ACK). The controller then sends a byte of data (B7 to B0), and the ACS422x67 acknowledges again by pulling SDA low.

When there is a low to high transition on SDA while SCL is high, the transfer is complete. After receiving a complete address and data sequence the ACS422x67 returns to the idle state. If a start or stop condition is detected out of sequence, the device returns to the idle condition.

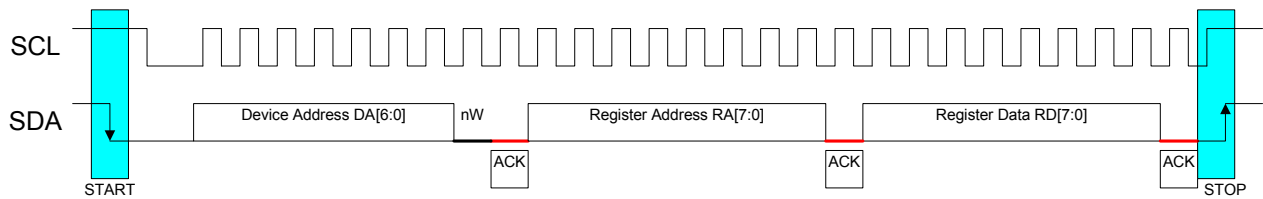

Figure 23. 2-Wire Serial Control Interface

The ACS422x67 has device address D2.

5.9.2. Multiple Write Cycle

The controller may write more than one register within a single write cycle. To write additional registers, the controller will not generate a stop or start (repeated start) command after receiving the acknowledge for the second byte of information (register address and data). Instead the controller will continue to send bytes of data. After each byte of data is received, the register address is incremented.

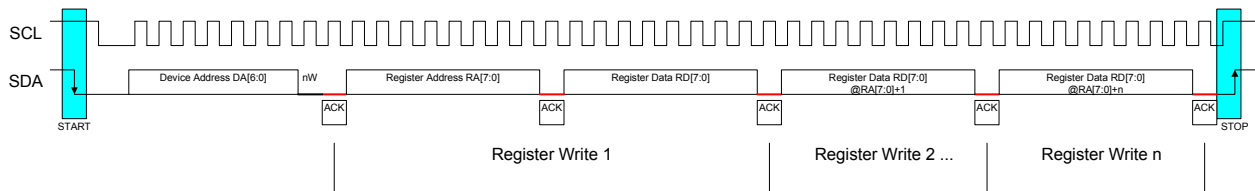

Figure 24. Multiple Write Cycle

5.9.3. Register Read Cycle

The controller indicates the start of data transfer with a high to low transition on SDA while SCL remains high, signalling that a device address and data will follow. If the device address received matches the address of the ACS422x67 and the R/W bit is '0', indicating a write, then the ACS422x67 responds by pulling SDA low on the next clock pulse (ACK); otherwise, the ACS422x67 returns to the idle condition to wait for a new start condition and valid address.

Once the ACS422x67 has acknowledged a correct address, the controller sends a restart command (high to low transition on SDA while SCL remains high). The controller then re-sends the devices address with the R/W bit set to '1' to indicate a read cycle. The ACS422x67 acknowledges by pulling SDA low for one clock pulse. The controller then receives a byte of register data (B7 to B0).

For a single byte transfer, the host controller will not acknowledge (high on data line) the data byte and generate a low to high transition on SDA while SCL is high, completing the transfer. If a start or stop condition is detected out of sequence, the device returns to the idle condition.

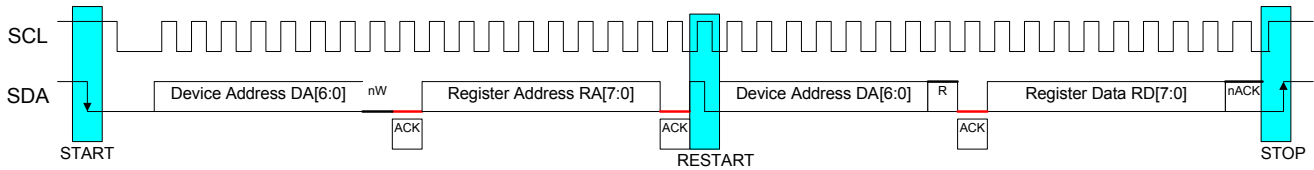

Figure 25. Read Cycle

The ACS422x67 has device address D2.

5.9.4. Multiple Read Cycle

The controller may read more than one register within a single read cycle. To read additional registers, the controller will not generate a stop or start (repeated start) command after sending the acknowledge for the byte of data. Instead the controller will continue to provide clocks and acknowledge after each byte of received data. The codec will automatically increment the internal register address after each register has had its data successfully read (ACK from host) but will not increment the register address if the data is not received correctly by the host (nACK from host) or if the bus cycle is terminated unexpectedly (however the EQ/Filter address will be incremented even if the register address is not incremented when performing EQ/Filter RAM reads). By automatically incrementing the internal register address after each byte is read, all the internal registers of the codec may be read in a single read cycle.

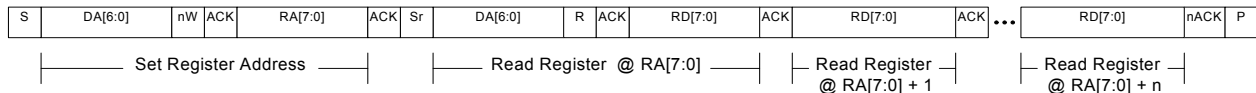

Figure 26. Multiple Read Cycle

5.9.5. Device Addressing and Identification

The ACS422x67 has a default slave address of D2. However, it is sometimes necessary to use a different address. The ACS422x67 has a device address register for this purpose. The part itself has an 8-bit Identification register and an 8-bit revision register that provide device specific information for software. In addition, an 8-bit programmable subsystem ID register can allow firmware to provide a descriptive code to higher level software such as an operating system driver or application software.

5.9.5.1. Device Registers

- Device Address Register**

| Register Address | Bit | Label | Type | Default | Description |
|----------------------|-----|-----------|------|---------|---|
| R124 (7Ch) DEVADR | 7:1 | ADDR[7:1] | RW | 1101001 | 7-bit slave address |
| | 0 | RSVD | R | 0 | Not used - this bit is the R/nW bit in the 2-wire protocol. |

Table 75. DEVADR Register

ACS422x67

LOW-POWER, HIGH-FIDELITY, INTEGRATED CODEC

- **Device Identification Registers**

| Register Address | Bit | Label | Type | Default | Description |
|----------------------|-----|-----------|------|---------|--|
| R126 (7Eh) DEVIDH | 7:0 | DID[15:8] | R | xxh | 16-bit device identification number. The ACS422x67 has programmable clocking that will drive different device IDs for each configuration. Contact TSI. |
| R125 (7Dh) DEVIDL | 7:0 | DID[7:0] | R | xxh | |

Table 76. DEVID H&L Registers

- **Device Revision Register**

| Register Address | Bit | Label | Type | Default | Description |
|---------------------|-----|----------|------|---------|---|
| R127 (7Fh) REVID | 7:4 | MAJ[3:0] | R | xh | 4-bit major revision number. Contact TSI. |
| | 3:0 | MNR[3:0] | R | xh | 4-bit minor revision number. Contact TSI. |

Table 77. REVID Register

Note: Contact TSI for device and revision information.

5.9.5.2. Register Reset

The ACS422x67 registers may be reset to their default values using the reset register. Writing a special, non-zero value to this register causes all other registers to assume their default states. Device status bits will not necessarily change their values depending on the state of the device.

| Register Address | Bit | Label | Type | Default | Description |
|---------------------|-----|------------|------|---------|---|
| R128 (80h) RESET | 7:0 | Reset[7:0] | RW | 00h | Reset register Writing a value of 85h will cause registers to assume their default values. Reading this register returns 00h |

Table 78. RESET Register

6. AUDIO CLOCK GENERATION

6.1. Internal Clock Generation

6.1.1. *Audio Master Clock (ACLK)*

In addition to providing external clocks, the PLL block will also provide two clocks for the audio portion of the device. They are

- 122.880 MHz (2560 x 48 KHz)
- 112.896 (2560 x 44.1 KHz)

6.1.2. *External MCLK or XTAL*

The ACS422x67 is designed to use an external clock or crystal (MCLK and XTAL) whose frequency is 11.2896MHz when playing 44.1KHz audio or 12.288MHz when playing 48KHz audio. Other frequencies are acceptable, but please contact your TSI support representative for assistance in ensuring compatibility. A crystal or active MCLK is required when power is applied for proper operation. MCLK/XTAL is required for I2S communication.

6.1.3. *REF Out*

The Ref Out is a buffered copy of MCLK/XTAL. It can also be set to 1/2 the input clock with setting in register R98 (62h).

6.2. ACLK Clocking and Sample Rates

The ACS422x67 utilizes internal PLLs to generate the audio master clocks (ACLK) at 56.448MHz (22.5792MHz *2.5) and 61.44MHz (24.576 *2.5). It then generates audio sample rates directly from the audio master clocks. The ADC and DAC do not need to run at the same sample rate unless they are sharing BCLK and LRCLK pins. Disable the appropriate converters before programming the mode or rate, especially if the DAC and ADC are programmed to share the same BCLK and LRCLK. After changing rate, a delay of up to 5mS may be needed for the part to properly lock PLLs,

ACS422x67

LOW-POWER, HIGH-FIDELITY, INTEGRATED CODEC

flush filters, etc.

| Register Address | Bit | Label | Type | Default | Description |
|--|-----|-----------|------|---------|---|
| R23 (17h) ADC Sample Rate Control (ADCSR) | 7:6 | ABCM[1:0] | RW | 00 | ADC Bit Clock Mode (for data interface ADCBCLK generation in master mode) 00 = Auto 01 = 32x fs 10 = 40x fs 11 = 64x fs |
| | 5 | RSVD | R | 0 | Reserved |
| | 4:3 | ABR[1:0] | RW | 10 | ADC Base Rate 00 = 32KHz 01 = 44.1KHz 10 = 48KHz 11 = Reserved |
| | 2:0 | ABM[2:0] | RW | 010 | ADC Base Rate Multiplier 000 = 0.25x 001 = 0.50x 010 = 1x 011 = 2x 100-111 = Reserved |

Table 79. ADCSR Register

| Register Address | Bit | Label | Type | Default | Description |
|--|-----|-----------|------|---------|---|
| R25 (19h) DAC Sample Rate Control (DACSR) | 7:6 | DBCM[1:0] | RW | 00 | DAC Bit Clock Mode (for data interface DACBCLK generation in master mode) 00 = Auto 01 = 32x fs 10 = 40x fs 11 = 64x fs |
| | 5 | RSVD | R | 0 | Reserved |
| | 4:3 | DBR[1:0] | RW | 10 | DAC Base Rate 00 = 32KHz 01 = 44.1KHz 10 = 48KHz 11 = Reserved |
| | 2:0 | DBM[2:0] | RW | 010 | DAC Base Rate Multiplier 000 = 0.25x 001 = 0.50x 010 = 1x 011 = 2x 100-111 = Reserved |

Table 80. DACSR Register

The clocking of the ACS422x67 is controlled using the BR[1:0] and BM[2:0] control bits. Each value of BR[1:0] + BM[2:0] selects one combination of ACLK division ratios and hence one combination of sample rates

ACS422x67

LOW-POWER, HIGH-FIDELITY, INTEGRATED CODEC

The BR[1:0] and BM[2:0] bits must be set to configure the appropriate ADC and DAC sample rates in both master and slave mode.

| BR [1:0] | BM [2:0] | ACLK | SAMPLE RATE |
|----------|----------|-----------|------------------------|
| 00 | 000 | 40.96 MHz | 8 kHz (ACLK/5120) |
| | 001 | | 16 kHz (ACLK/2560) |
| | 010 | | 32 kHz (ACLK/1280) |
| | 011 | | Reserved |
| | 100-111 | | Reserved |
| 01 | 000 | 56.448MHz | 11.025 kHz (ACLK/5120) |
| | 001 | | 22.05 kHz (ACLK/2560) |
| | 010 | | 44.1 kHz (ACLK/1280) |
| | 011 | | 88.2 kHz (ACLK/640) |
| | 100-111 | | Reserved |
| 10 | 000 | 61.44 MHz | 12 kHz (ACLK/5120) |
| | 001 | | 24 kHz (ACLK/2560) |
| | 010 | | 48 kHz (ACLK/1280) |
| | 011 | | 96 kHz (ACLK/640) |
| | 100-111 | | Reserved |
| 11 | 000-111 | - | Reserved |

Table 81. ACLK and Sample Rates

6.3. DAC/ADC Modulator Rate Control

The power consumption and audio quality may be adjusted by changing the converter modulator rate. By default the DAC and ADC Sigma-Delta modulators run at a high rate for the best audio quality. The modulator rates for the converters may be forced to run at half their nominal rate to conserve power. A third option allows the modulator rate to automatically drop to half rate when low sampling rates are chosen (1/2 or 1/4 the base rate.) The DACs and ADCs are independently controlled.

| Register Address | Bit | Label | Type | Default | Description |
|----------------------|-----|-------------|------|---------|--|
| R31 (1Fh) CONFIG0 | 7:6 | ASDM[1:0] | RW | 10h | ADC Modulator Rate 00 = Reserved 01 = Half 10 = Full 11 = Auto |
| | 5:4 | DSDM[1:0] | RW | 10h | DAC Modulator Rate 00 = Reserved 01 = Half 10 = Full 11 = Auto |
| | 3:2 | RSVD | R | 0h | Reserved for future use. |
| | 1 | dc_bypass | RW | 0 | 1 = bypass DC removal filter (WARNING DC content can damage speakers) |
| | 0 | sd_force_on | R | 0 | 1 = supply detect forced on. 0 = supply detect on when needed (COP, UVLO enabled). |

Table 82. CONFIG0 Register

| DSDM[1:0] ASDM[1:0] | BM [2:0] | Modulator Rate |
|------------------------|------------|----------------|
| 00 | NA | Reserved |
| 01 | 000 (1/4x) | Half |
| | 001 (1/2x) | |
| | 010 (1x) | |
| | 011 (2x) | |
| 10 | 000 (1/4x) | Full |
| | 001 (1/2x) | |
| | 010 (1x) | |
| | 011 (2x) | |
| 11 | 000 (1/4x) | Auto (Half) |
| | 001 (1/2x) | Auto (Half) |
| | 010 (1x) | Auto (Full) |
| | 011 (2x) | Auto (Full) |

Table 83. SDM Rates

7. CHARACTERISTICS

7.1. Electrical Specifications

7.1.1. Absolute Maximum Ratings

Stresses above the ratings listed below can cause permanent damage to the ACS422x67. These ratings, which are standard values for TSI commercially rated parts, are stress ratings only. Functional operation of the device at these or any other conditions above those indicated in the operational sections of the specifications is not implied. Exposure to absolute maximum rating conditions for extended periods can affect product reliability. Electrical parameters are guaranteed only over the recommended operating temperature range.

| Item | Maximum Rating |
|---------------------------------------|--------------------------|
| Voltage on any pin relative to Ground | Vss - 0.3V TO Vdd + 0.3V |
| Operating Temperature | 0 °C TO 70 °C |
| Storage Temperature | -55 °C TO +125 °C |
| Soldering Temperature | 260 °C |
| MICBias Output Current | 3mA |
| Amplifier Maximum Supply Voltage | 6 Volts = PVDD |
| Audio Maximum Supply Voltage | 3 Volts = AVDD/CPVDD |
| Digital I/O Maximum Supply Voltage | 3.6 Volts = DVDD_IO |
| Digital Core Maximum Supply Voltage | 2.0 Volts = DVDD |

Table 84. Electrical Specification: Maximum Ratings

7.1.2. Recommended Operating Conditions

| Parameter | | Min. | Typ. | Max. | Units |
|-------------------------------|-------------------|------|------|------|-------|
| Power Supplies | DVDD_Core | 1.4 | | 2.0 | V |
| | DVDD_IO | 1.4 | | 3.5 | |
| | AVDD/CPVDD | 1.7 | | 2.0 | |
| | PVDD | 3.0 | | 5.5 | V |
| Ambient Operating Temperature | Analog - 5 V | 0 | 25 | 70 | °C |
| Case Temperature | T _{case} | | | 90 | °C |

Table 85. Recommended Operating Conditions

ESD: The ACS422x67 is an ESD (electrostatic discharge) sensitive device. The human body and test equipment can accumulate and discharge electrostatic charges up to 4000 Volts without detection. Even though the ACS422x67 implements internal ESD protection circuitry, proper ESD precautions should be followed to avoid damaging the functionality or performance.

7.2. Device Characteristics

(T_{ambient} = 25 °C, DVDD_CORE=DVDD_IO=AVDD=1.9V, PVDD=3.6V, 997Hz signal, fs=48KHz, Input Gain=0dB, 24-bit audio)

| Parameter | Symbol | Test Conditions | Min | Typ | Max | Unit |
|---|-------------------|---|-----|-------------|-----|-------------|
| Analog Inputs (L_{IN1}, L_{IN2}, L_{IN3}, R_{IN1}, R_{IN2}, R_{IN3}) | | | | | | |
| Full Scale Input Voltage | V _{FSIV} | L/R _{IN1,2,3} Single Ended | | 0.5 -6 | | Vrms dBV |
| | | L/R _{IN1,2,3} Differential Mic | | 0.5 -6 | | Vrms dBV |
| Input Impedance | | | | 50 | | Kohm |
| Input Capacitance | | | | 10 | | pF |
| Analog Input Boost Amplifier | | | | | | |
| Programmable Gain Min | | | | 0.0 | | dB |
| Programmable Gain Max | | | | 30.0 | | dB |
| Programmable Gain Step Size | | | | 10.0 | | dB |
| Analog Input PGA | | | | | | |
| Programmable Gain Min | | | | -17.25 | | dB |
| Programmable Gain Max | | | | 30.0 | | dB |
| Programmable Gain Step Size | | Guaranteed Monotonic | | 0.75 | | dB |
| Digital Volume Control Amplifier | | | | | | |
| Programmable Gain Min | | | | -97 | | dB |
| Programmable Gain Max | | | | 30.0 | | dB |
| Programmable Gain Step Size | | Guaranteed Monotonic | | 0.5 | | dB |
| Mute Attenuation | | | | -999 | | dB |
| Analog Inputs (L_{IN1}/R_{IN1}, L_{IN2}/R_{IN2} Differential) to ADC | | | | | | |
| Signal To Noise Ratio | SNR | A-weighted 20-20KHz | | 90 | | dB |
| Total Harmonic Distortion + Noise | THD+N | -1dBFS input | | -80 0.01 | | dB % |
| Analog Inputs (L_{IN1}, L_{IN2}, L_{IN3}, R_{IN1}, R_{IN2}, R_{IN3} Single Ended) to ADC | | | | | | |
| Signal To Noise Ratio | SNR | A-weighted 20-20KHz | | 90 | | dB |
| Total Harmonic Distortion + Noise | THD+N | -1dBFS input | | -80 0.01 | | dB % |
| ADC channel Separation | | 997Hz full scale signal | | 70 | | dB |
| Channel Matching | | 997Hz signal | | | 2 | % |
| DAC to Line-Out (HPL, HPR with 10K / 50pF load) | | | | | | |
| Signal to Noise Ratio ¹ | SNR | A-weighted | | 102 | | dB |
| Total Harmonic Distortion +Noise ² | THD+N | 997Hz full scale signal | | -84 | | dB |
| Channel Separation | | 997Hz full scale signal | | 70 | | dB |
| Mute attenuation | | | | -999 | | dB |
| Headphone Outputs (HPL, HPR) | | | | | | |
| Full Scale Output Level | V _{FSOV} | RL = 10Kohm | | 1.0 | | Vrms |
| | | RL = 16ohm | | 0.75 | | Vrms |
| Output Power | P _O | 997Hz full scale signal, RL = 16ohm | | 35 | | mW (ave) |
| Signal to Noise Ratio | SNR | A-weighted, RL = 16ohm | | 102 | | dB |

Table 86. Device Characteristics

ACS422x67

LOW-POWER, HIGH-FIDELITY, INTEGRATED CODEC

| Parameter | Symbol | Test Conditions | Min | Typ | Max | Unit |
|---|-----------------------------------|---|---------------------|-----------------|-----------------|------------------|
| Total Harmonic Distortion +Noise | THD+N | R _L = 16ohms, -3dBFS | | -76 | | dB |
| | | R _L = 32ohms, -3dBFS | | -78 | | dB |
| Speaker Outputs (L+, L-, R+, R- with 8ohms bridge-tied load) | | | | | | |
| Full Scale Output Level | V _{F_{SOV}} | PVDD=5V PVDD=3.6V | | 3.0 2.1 | | V _{rms} |
| Output Power | P _O | 997Hz full scale signal, output power mode disabled PVDD=5V, 8ohm PVDD=3.6V, 8ohm | 1 0.5 | | | W(ave) |
| | | PVDD = 5V, 4 ohm DIDD = 3.6V, 4 ohm | 2 1 | | | W(ave) |
| Signal to Noise Ratio | SNR | A-weighted | | 90 | | dB |
| Total Harmonic Distortion + Noise | THD+N | 5V/8ohms/0.5W | | 0.05 | | % |
| Speaker Supply Leakage Current | I _{PVDD} | | | 1 | | uA |
| Efficiency | h | PVDD=3.6V RL=8,P _O = 0.5W | | 87 | | % |
| | | PVDD=5V RL=8,P _O = 1W | | 87 | | |
| | | PVDD=3.6V RL=4,P _O = 1W | | 83 | | |
| | | PVDD=5V RL=4,P _O = 2W | | 83 | | |
| Analog Voltage Reference Levels | | | | | | |
| Charge Pump Output | V- | | -5% | -AVDD +100mV | +5% | V |
| Microphone Bias | | | | | | |
| Bias Voltage | V _{MICBIAS} | | - | 2.5 | - | V |
| BIAS current Source | | | | | 3 | mA |
| Power Supply Rejection Ratio | PSRR _{MICBIAS} | 3.3V<PVDD<5.25V | | 80 | | dB |
| | | 3.0V<PVDD<3.3V | | 40 | | dB |
| Digital Input/Output | | | | | | |
| ADC/DAC BCLK input rate | F _{max} | | | 30 | | MHz |
| I2S BCLK/LRCLK ratio | | | 32 | | 1022 | clocks/ frame |
| Input High Level | V _{IH} | | 0.7x DVDD_ IO | | | V |
| Input LOW Level | V _{IL} | | | | 0.3x DVDD_IO | V |
| Output High Level | V _{OH} | I _{OH} =-1mA | 0.9x DVDD_IO | | | V |
| Output LOW Level | V _{OL} | I _{OL} =1mA | | 0.1xDVDD_IO | | V |
| Input Capacitance | | | | 5 | | pF |
| Input Leakage | | | -0.9 | | 0.9 | uA |
| Internal Pull-Up Resistor | R _{PU} / R _{PU} | All Digital I/O pins with pull-up or pull-down | | 50 | | kΩ |
| ESD / Latchup | | | | | | |
| IEC1000-4-2 | | | 1 | | | Level |
| JESD22-A114-B | | | 2 | | | Class |
| JESD22-C101 | | | 4 | | | Class |

Table 86. Device Characteristics

ACS422x67

LOW-POWER, HIGH-FIDELITY, INTEGRATED CODEC

1. Ratio of Full Scale signal to idle channel noise output is measured "A weighted" over a 20 Hz to a 20 kHz bandwidth. (AES17-1991 Idle Channel Noise or EIAJ CP-307 Signal-to-noise Ratio).
2. THD+N ratio as defined in AES17 and outlined in AES6id, non-weighted, swept over 20 Hz to 20 kHz bandwidth.

7.3. PLL Electrical Characteristics

Unless stated otherwise, DVDD_Core=1.8V -0.1V/+0.2V, Ambient Temp -10C to +80C

| Parameter | Symbol | Test Conditions | Min | Typ | Max | Unit |
|-----------------------------|-----------------------------|-------------------------|-------------------|--------|---------------|------|
| Operating Voltage | DVDD_CORE | | 1.7 | 1.8 | 2.0 | V |
| Supply Current | I _{DVDD_CORE(PLL)} | No Load, VDD=1.9V | | 3 | 15 | mA |
| Input High Level | V _{IH} | | 0.7x DVDD_CORE | | | V |
| Input LOW Level | V _{IL} | | | | 0.3xDVDD_CORE | V |
| Input Capacitance | C _{IN} | | | 5 | | pF |
| Load Capacitance, X1 and X2 | C _L | | | 5 | | pF |
| Internal Pull-Down Resistor | R _{PD} | All clock outputs | 75 | 250 | | kΩ |
| Output High Level | V _{OH} | I _{OH} =-2mA | 0.8x DVDD_CORE | | | V |
| Output LOW Level | V _{OL} | I _{OL} =2mA | | | 0.2xDVDD_CORE | V |
| Input Frequency | f _{IN} | | 2 | 12.288 | 100 | MHz |
| Output Rise Time | t _{OR} | 20% to 80% ¹ | 1.1 | 2.2 | 3.3 | ns |
| Output Fall Time | t _{OF} | 80% to 20% ¹ | 1.1 | 2.2 | 3.3 | ns |
| Output Impedance | R _O | VO=VDD/2 | 33 | 46 | 68 | Ω |

Table 87. PLL Section DC Characteristics

1. Measured with a 5pF load.

8. REGISTER MAP

| Register (D15:9) | Name | Remarks | Bit[7] | Bit[6] | Bit[5] | Bit[4] | Bit[3] | Bit[2] | Bit[1] | Bit[0] | Default | |
|------------------|------------|------------------------------------|--------------|--------------|----------------|----------------|----------------|------------|---------------|-------------|---------|-----|
| R0 (00h) | HPVOLL | Left HP volume | | | | | | | HPVOL_L[6:0] | | | 77h |
| R1 (01h) | HPVOLR | Right HP volume | | | | | | | HPVOL_R[6:0] | | | 77h |
| R2 (02h) | SPKVOLL | SPKR Left volume | | | | | | | SPKVOL_L[6:0] | | | 6Fh |
| R3 (03h) | SPKVOLR | SPKR Right volume | | | | | | | SPKVOL_R[6:0] | | | 6Fh |
| R4 (04h) | DACVOLL | Left DAC volume | | | | | | | DACVOL_L[7:0] | | | FFh |
| R5 (05h) | DACVOLR | Right DAC volume | | | | | | | DACVOL_R[7:0] | | | FFh |
| R6 (06h) | ADCVOLL | Left ADC volume | | | | | | | ADCVOL_L[7:0] | | | BFh |
| R7 (07h) | ADCVOLR | Right ADC volume | | | | | | | ADCVOL_R[7:0] | | | BFh |
| R8 (08h) | INVOLL | Left Input volume | | IZCL | INVOL_L | | | | | | | 17h |
| R9 (09h) | INVOLR | Right Input volume | | IZCR | INVOL_R | | | | | | | 17h |
| R10 (0Ah) | VUCTL | Volume Update Control | ADCFade | DACFade | | INVOLU | ADCVOLU | DACVOLU | SPKVOLU | HPVOLU | C0h | |
| R11 (0Bh) | INMODE | ADC input mode | | | | | | | | DS | 00h | |
| R12 (0Ch) | INSELL | ADCL signal path | INSEL_L[1:0] | | MICBST_L[1:0] | | | | | | 00h | |
| R13 (0Dh) | INSELR | ADCR signal path | INSEL_R[1:0] | | MICBST_R[1:0] | | | | | | 00h | |
| R14 (0Eh) | ALC0 | ALC0 | | | | | | ALC MODE | ALCSEL[1:0] | | 00h | |
| R15 (0Fh) | ALC1 | ALC1 | | MAXGAIN[2:0] | | | ALCL[3:0] | | | | 7Bh | |
| R16 (10h) | ALC2 | ALC2 | | MINGAIN[2:0] | | | HLD[3:0] | | | | 00h | |
| R17 (11h) | ALC3 | ALC3 | | DCY[3:0] | | | ATK[3:0] | | | | 32h | |
| R18 (12h) | NGATE | Noise Gate | NGTH[4:0] | | | | | NGG[1:0] | | NGAT | | 00h |
| R19 (13h) | AIC1 | Audio Interface 1 | | BCLKINV | MS | LRP | WL[1:0] | | FORMAT[1:0] | | 0Ah | |
| R20 (14h) | AIC2 | Audio Interface 2 | DACDSEL[1:0] | | ADCDSEL[1:0] | | TRI | BLRCM[2:0] | | | 00h | |
| R21 (15h) | AIC3 | Audio Interface 3 | | | ADOPDD | ALRPDD | ABCPDD | DDIPDD | DLRPDD | DBCDD | 00h | |
| R22 (16h) | CNVTR0 | ADC Control | ADCPOLR | ADCPOLL | AMONOMIX[1:0] | | ADCMU | HPOR | ADCHPDR | ADCHPDL | 08h | |
| R23 (17h) | ADCSR | ADC Sample rate | ABCM[1:0] | | | ABR[1:0] | | ABM[2:0] | | | 12h | |
| R24 (18h) | CNVTR1 | DAC Control | DACPOLR | DACPOLL | DMONOMIX[1:0] | | DACMU | DEEMPH | | | 08h | |
| R25 (19h) | DACSR | DAC Sample rate | DBCM[1:0] | | | DBR[1:0] | | DBM[2:0] | | | 12h | |
| R26 (1Ah) | PWRM1 | Pwr Mgmt (1) | BSTL | BSTR | PGAL | PGAR | ADCL | ADCR | MICB | DIGENB | 00h | |
| R27 (1Bh) | PWRM2 | Pwr Mgmt (2) | D2S | HPL | HPR | SPKL | SPKR | | | VREF | 00h | |
| R28 (1Ch) | CTL | Additional control | HPSWEN | HPSWPOL | EQ2SW1 | EQ2SW0 | EQ1SW1 | EQ1SW0 | TSDEN | TOEN | 00h | |
| R29 (1Dh) | THERMTS | Temp Sensor Control | TripHighStat | TripLowStat | TripSplit[1:0] | | TripShift[1:0] | | Poll[1:0] | | 09h | |
| R30 (1Eh) | THERMSPKR1 | Speaker Thermal Algorithm Control | ForcePwD | InstCutMod e | IncRatio[1:0] | | IncStep[1:0] | | DecStep[1:0] | | 81h | |
| R31 (1Fh) | CONFIG0 | CONFIG0 | ASDM1 | ASDM0 | DSDM1 | DSDM0 | | | dc_bypass | sd_force_on | A0h | |
| R32 (20h) | CONFIG1 | CONFIG1 | EQ2_EN | EQ2_BE2 | EQ2_BE1 | EQ2_BE0 | EQ1_EN | EQ1_BE2 | EQ1_BE1 | EQ1_BE0 | 00h | |
| R33 (21h) | GAINCTL | Gain Control | zerodet_flag | zerodetlen1 | | zerodetlen0 | | auto_mute | | | | 24h |
| R34 (22h) | COP1 | Constant Output Power1 | COPAtten | COPGain | HDeltaEn | COPTarget[4:0] | | | | | 08h | |
| R35 (23h) | COP2 | Constant Output Power2 | | HDCOMP MODE | AvgLength[3:0] | | | | MonRate[1:0] | | 02h | |
| R36 (24h) | DMICCTL | D-Mic Control | DMicEn | | | DMono | DMPHAdj1 | DMPHAdj0 | DMRate1 | DMRate0 | 00h | |
| R37 (25h) | CLECTL | CMPLMCTL | | | Lv_Mode | WindowSel | Exp_En | Limit_En | Comp_En | | 00h | |
| R38 (26h) | MUGAIN | CLEMakeUpGain | | | CLEMUG4 | CLEMUG3 | CLEMUG2 | CLEMUG1 | CLEMUG0 | | 00h | |
| R39 (27h) | COMPTh | Compressor Threshold | COMPTh7 | COMPTh6 | COMPTh5 | COMPTh4 | COMPTh3 | COMPTh2 | COMPTh1 | COMPTh0 | 00h | |
| R40 (28h) | CMPRAT | Compressor Ratio | | | CMPRAT4 | CMPRAT3 | CMPRAT2 | CMPRAT1 | CMPRAT0 | | 00h | |
| R41 (29h) | CATKCTL | Comp Attack time const Low | CATKTC7 | CATKTC6 | CATKTC5 | CATKTC4 | CATKTC3 | CATKTC2 | CATKTC1 | CATKTC0 | 00h | |
| R42(2Ah) | CATKCH | Comp Attack time const High | CATKTC15 | CATKTC14 | CATKTC13 | CATKTC12 | CATKTC11 | CATKTC10 | CATKTC9 | CATKTC8 | 00h | |
| R43 (2Bh) | CRELTCL | Comp release time const Low | CRELTC7 | CRELTC6 | CRELTC5 | CRELTC4 | CRELTC3 | CRELTC2 | CRELTC1 | CRELTC0 | 00h | |
| R44 (2Ch) | CRELTCH | Comp release time const High | CRELTC15 | CRELTC14 | CRELTC13 | CRELTC12 | CRELTC11 | CRELTC10 | CRELTC9 | CRELTC8 | 00h | |
| R45 (2Dh) | LIMTH | Limiter Threshold | LIMTH7 | LIMTH6 | LIMTH5 | LIMTH4 | LIMTH3 | LIMTH2 | LIMTH1 | LIMTH0 | 00h | |
| R46 (2Eh) | LIMTGT | Limiter Target | LIMTGT7 | LIMTGT6 | LIMTGT5 | LIMTGT4 | LIMTGT3 | LIMTGT2 | LIMTGT1 | LIMTGT0 | 00h | |
| R47 (2Fh) | LATKCTL | Limiter Attack time constant Low | LATKTC7 | LATKTC6 | LATKTC5 | LATKTC4 | LATKTC3 | LATKTC2 | LATKTC1 | LATKTC0 | 00h | |
| R48 (30h) | LATKCH | Limiter Attack time constant High | LATKTC15 | LATKTC14 | LATKTC13 | LATKTC12 | LATKTC11 | LATKTC10 | LATKTC9 | LATKTC8 | 00h | |
| R49 (31h) | LRELTCL | Limiter Release time constant Low | LRELTC7 | LRELTC6 | LRELTC5 | LRELTC4 | LRELTC3 | LRELTC2 | LRELTC1 | LRELTC0 | 00h | |
| R50 (32h) | LRELTCH | Limiter Release time constant High | LRELTC15 | LRELTC14 | LRELTC13 | LRELTC12 | LRELTC11 | LRELTC10 | LRELTC9 | LRELTC8 | 00h | |
| R51 (33h) | EXPTH | Expander Threshold | EXPTH7 | EXPTH6 | EXPTH5 | EXPTH4 | EXPTH3 | EXPTH2 | EXPTH1 | EXPTH0 | 00h | |

Table 88. Register Map

ACS422x67

LOW-POWER, HIGH-FIDELITY, INTEGRATED CODEC

| Register (D15:9) | Name | Remarks | Bit[7] | Bit[6] | Bit[5] | Bit[4] | Bit[3] | Bit[2] | Bit[1] | Bit[0] | Default |
|-----------------------|------------|-------------------------------------|---|----------------|-----------|-----------|-----------|------------------|----------|----------|------------------|
| R52 (34h) | EXPRAT | Expander Ratio | | | | | | EXPRAT2 | EXPRAT1 | EXPRAT0 | 00h |
| R53 (35h) | XATKTCL | Expander Attack time constant Low | XATKTCL7 | XATKTCL6 | XATKTCL5 | XATKTCL4 | XATKTCL3 | XATKTCL2 | XATKTCL1 | XATKTCL0 | 00h |
| R54 (36h) | XATKTCH | Expander Attack time constant High | XATKTCL15 | XATKTCL14 | XATKTCL13 | XATKTCL12 | XATKTCL11 | XATKTCL10 | XATKTCL9 | XATKTCL8 | 00h |
| R55 (37h) | XRELTC | Expander Release time constant Low | XRELTC7 | XRELTC6 | XRELTC5 | XRELTC4 | XRELTC3 | XRELTC2 | XRELTC1 | XRELTC0 | 00h |
| R56 (38h) | XRELTC | Expander Release time constant High | XRELTC15 | XRELTC14 | XRELTC13 | XRELTC12 | XRELTC11 | XRELTC10 | XRELTC9 | XRELTC8 | 00h |
| R57 (39h) | FXCTL | Effects Control | | | | 3DEN | TEEN | TNLFBYP | BEEN | BNLFBYP | 00h |
| R58 (3Ah) | DACCRWRL | DACCRAM_WRITE_LO | DACCRWD[7:0] | | | | | | | | 00h |
| R59 (3Bh) | DACCRWRM | DACCRAM_WRITE_MID | DACCRWD[15:8] | | | | | | | | 00h |
| R60 (3Ch) | DACCRWRH | DACCRAM_WRITE_HI | DACCRWD[23:16] | | | | | | | | 00h |
| R61 (3Dh) | DACCRDL | DACCRAM_READ_LO | DACCRRD[7:0] | | | | | | | | 00h |
| R62 (3Eh) | DACCRDM | DACCRAM_READ_MID | DACCRRD[15:8] | | | | | | | | 00h |
| R63 (3Fh) | DACCRDH | DACCRAM_READ_HI | DACCRRD[23:16] | | | | | | | | 00h |
| R64 (40h) | DACCRADDR | DACCRAM_ADDR | DACCRADD[7:0] | | | | | | | | 00h |
| R65 (41h) | DCOFSEL | DC_COEF_SEL | | | | | | dc_coef_sel[2:0] | | | 05h |
| R66-123 | RSVD | | RSVD | | | | | | | | NA |
| R124(7Ch) | DEVADR | I2C Device Address | ADDR7 | ADDR6 | ADDR5 | ADDR4 | ADDR3 | ADDR2 | ADDR1 | ADDR0 | D2h |
| R125(7Dh) | DEVIDL | Device IDLow | DID7 | DID6 | DID5 | DID4 | DID3 | DID2 | DID1 | DID0 | xxh ¹ |
| R126(7Eh) | DEVIDH | Device ID High | DID15 | DID14 | DID13 | DID12 | DID11 | DID10 | DID9 | DID8 | xxh ¹ |
| R127(7Fh) | REVID | Device Revision | MAJ3 | MAJ2 | MAJ1 | MAJ0 | MNR3 | MNR2 | MNR1 | MNR0 | xxh ² |
| R128(80h) | RESET | Reset | Writing 0x85 to this register resets all registers to their default state | | | | | | | | 00h |
| R129-R135 (81h - 87h) | Reserved | | RSVD | | | | | | | | NA |
| R136(88h) | THERMSPKR2 | Speaker Thermal Algorithm Status | ForcePwd Status | VolStatus[6:0] | | | | | | | 08h |
| R137-R255 (88h-FFh) | Reserved | | RSVD | | | | | | | | NA |

Table 88. Register Map

1. Please see the DEVID Register.
2. For device revision information, please contact TSI.

Note:

- Registers not described in this map should be considered “reserved”.
- Numerous portions of the register map are compatible with popular codecs from other vendors.

9. PIN INFORMATION

9.1. ACS422A67 QFN Pin Diagram

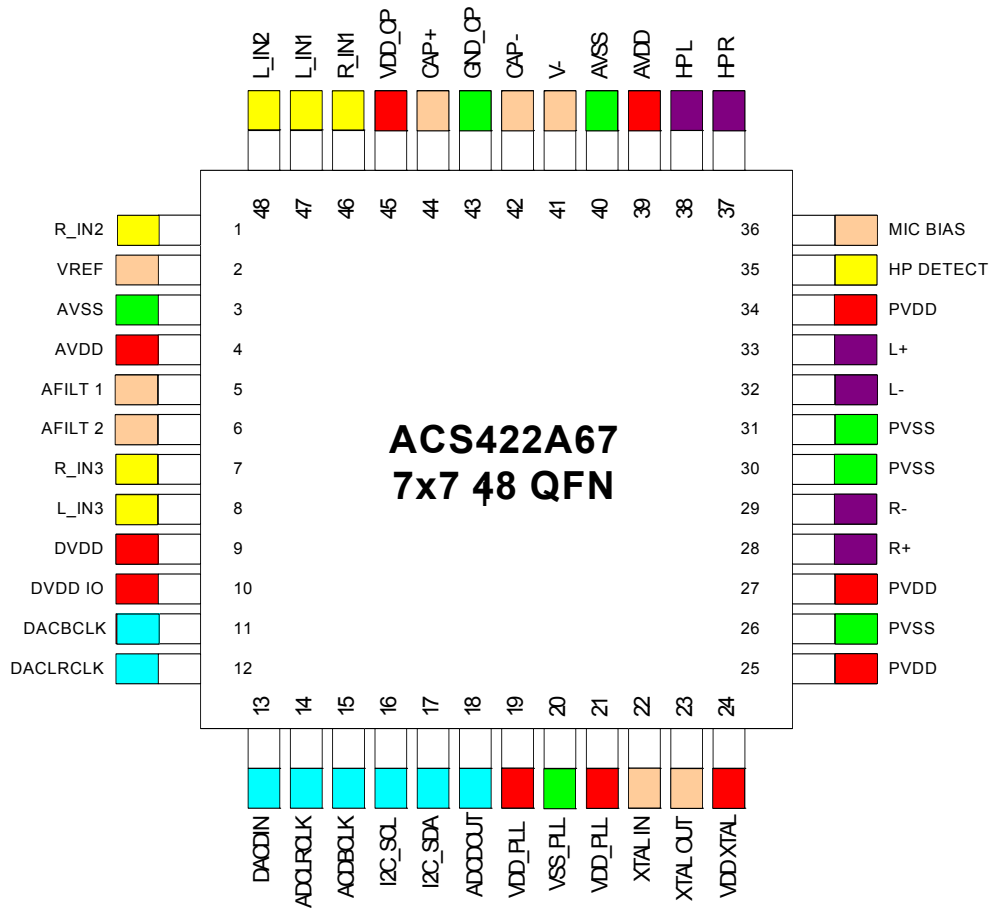

Figure 27. ACS422A67 Pinout

9.2. ACS422D67 QFN Pin Diagram

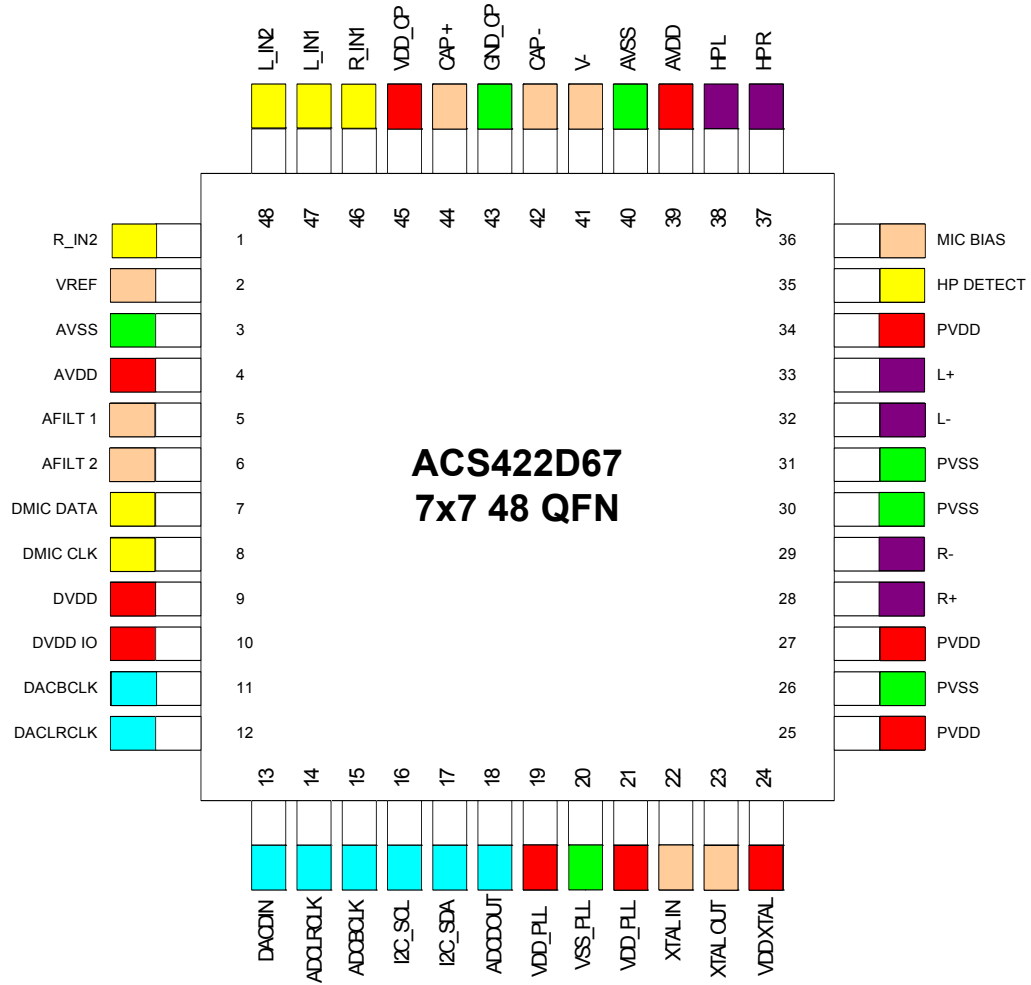

Figure 28. ACS422D67 Pinout

9.3. ACS422A67TAG Pin Diagram

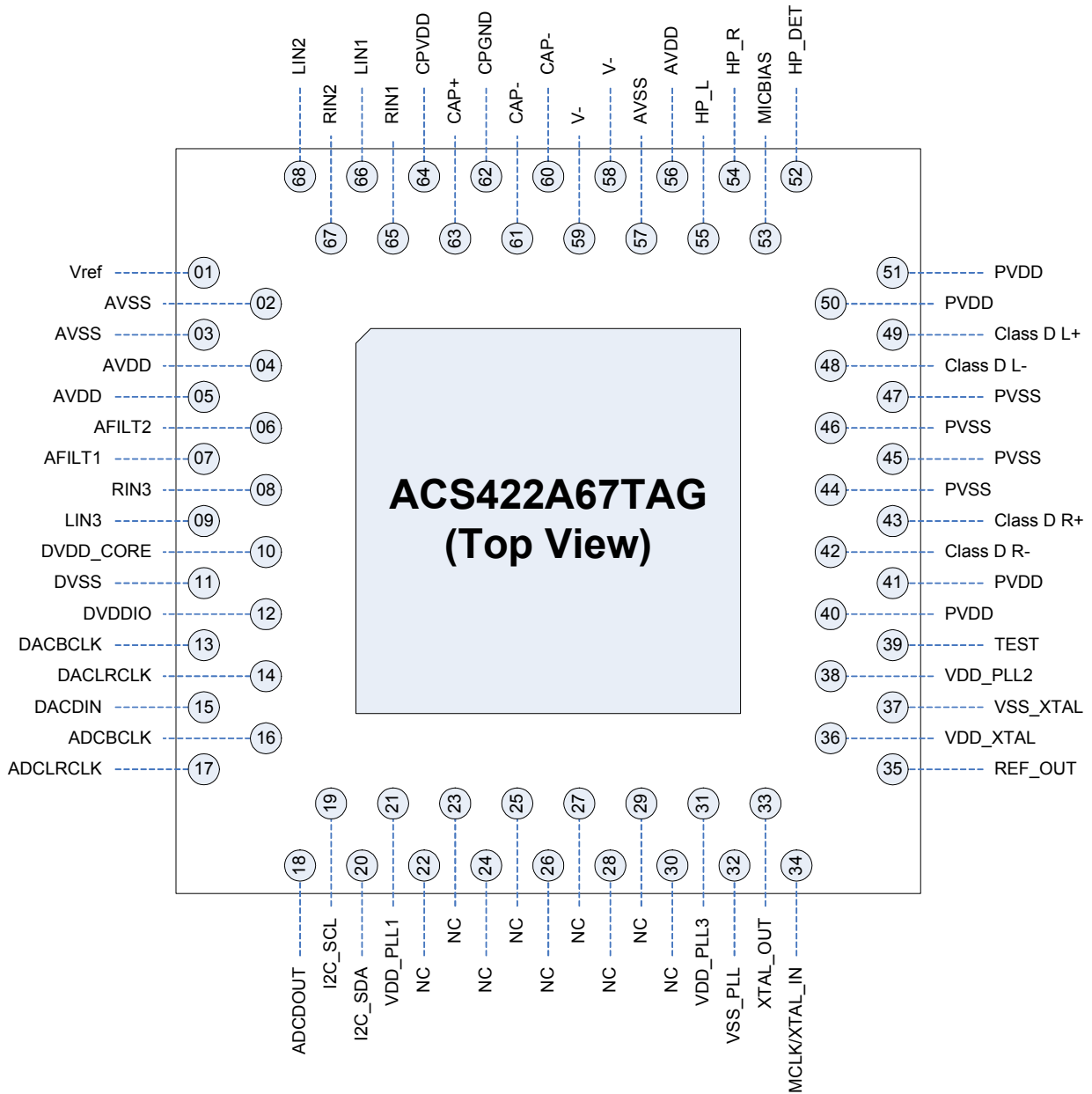

Figure 29. ACS422A67 Pinout

9.4. ACS422D67 Pin Diagram

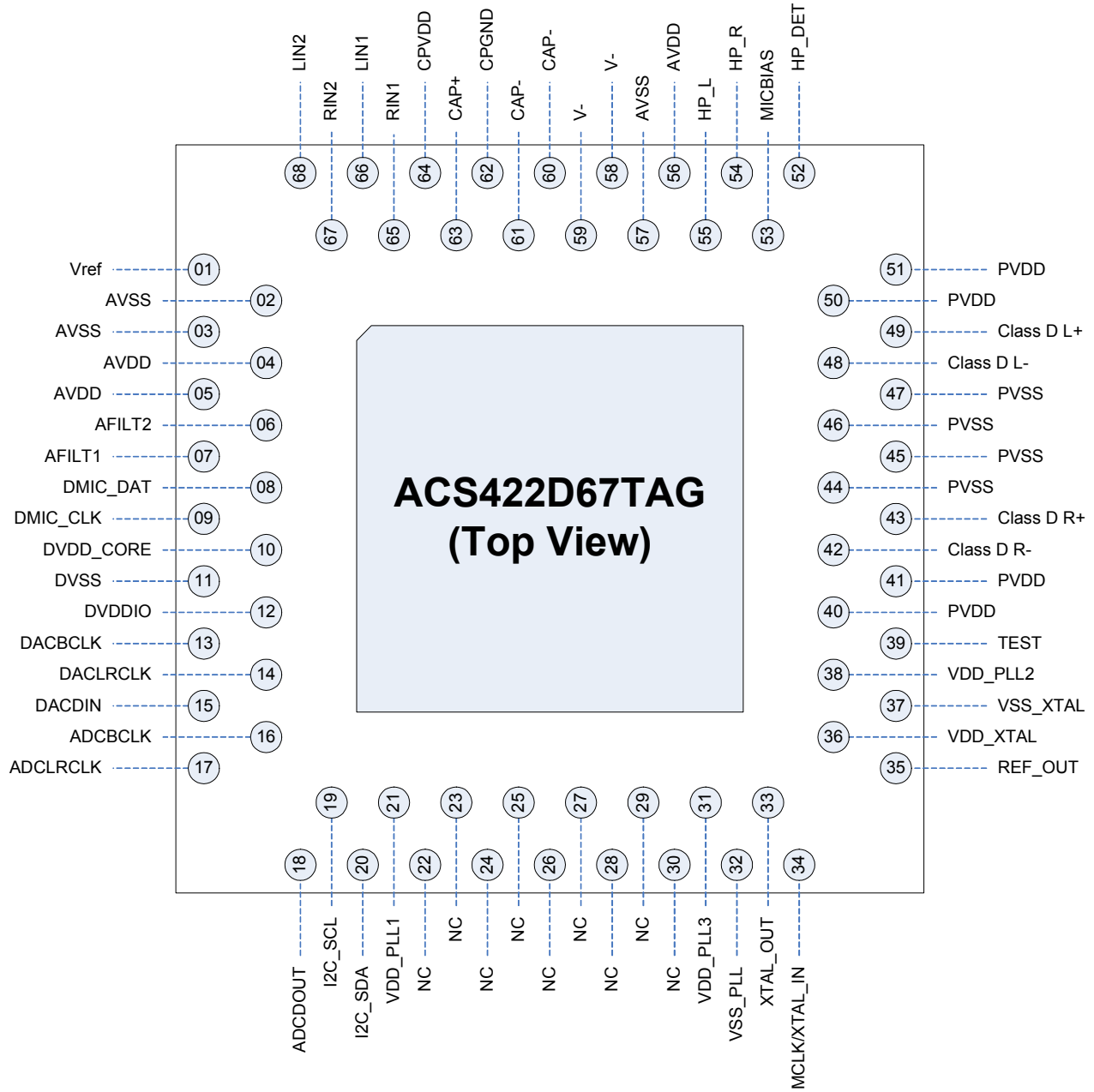

Figure 30. ACS422D67 Pinout

9.5. TLA Pin Tables

9.5.1. Power Pins

| Pin Name | Pin Function | I/O | Internal Pull-up Pull-down | TLA Pin location | QFN Pin location |
|-----------|--|------------|----------------------------|------------------|------------------|
| PVDD | BTL supply | I(Power) | None | 40, 41, 50,51 | 25,27,34 |
| PVSS | BTL supply | I(Power) | None | 44, 45, 46, 47 | 26,30,31 |
| DVDD_Core | DSP and other core logic+clocks | I(Power) | None | 10 | 9 |
| DVDDIO | Interface (I ² S, I ² C, GPIO) | I(Power) | None | 12 | 10 |
| DVSS | Digital return | I(Power) | None | 11 | DAP |
| AVDD | Analog core supply | I(Power) | None | 4, 5, 56 | 4,39 |
| AVSS | Analog return | I(Power) | None | 2, 3, 57 | 3,40 |
| CPVDD | Charge pump supply | I(Power) | None | 64 | 45 |
| CAP+ | Flying cap | I/O(Power) | None | 63 | 44 |
| CAP- | Flying cap | I/O(Power) | None | 60, 61 | 42 |
| V- | Negative Analog supply (Bypass cap) | O(Power) | None | 58, 59 | 41 |
| CPGND | Charge pump group | I(Power) | None | 62 | 43 |
| VDD_PLL1 | PLL supply | I(Power) | None | 21 | 19 |
| VDD_PLL3 | PLL supply | I(Power) | None | 31 | 21 |
| VDD_PLL2 | PLL supply | I(Power) | None | 38 | - |
| VDD_XTAL | Oscillator supply | I(Power) | None | 36 | 24 |
| VSS_PLL | PLL return | I(Power) | None | 32 | 20 |
| VSS_XTAL | Oscillator return | I(Power) | None | 37 | - |

Table 89. Power Pins

Total Pins: 30

9.5.2. Reference Pins

| Pin Name | Pin Function | I/O | Internal Pull-up Pull-down | TLA Pin location | QFN Pin location |
|----------|-----------------------------|-----------|----------------------------|------------------|------------------|
| MICBIAS | 2.5V 1.5 mA microphone bias | O(Analog) | None | 53 | 36 |
| AFILT1 | ADC input filter cap | I(Analog) | None | 7 | 5 |
| AFILT2 | ADC input filter cap | I(Analog) | None | 6 | 6 |
| Vref | VREF reference pin (bypass) | I(Analog) | None | 1 | 2 |

Table 90. Reference Pins

Total Pins: 4

ACS422x67

LOW-POWER, HIGH-FIDELITY, INTEGRATED CODEC

9.5.3. Analog Input Pins

| Pin Name | Pin Function | I/O | Internal Pull-up Pull-down | TLA Pin location | QFN Pin location |
|------------------|--|-----------|-------------------------------|---------------------|---------------------|
| LIN1 | Left Input #1 | I(Analog) | None | 66 | 47 |
| RIN1 | Right Input #1 | I(Analog) | None | 65 | 46 |
| LIN2 | Left Input #2 | I(Analog) | None | 68 | 48 |
| RIN2 | Right Input #2 | I(Analog) | None | 67 | 1 |
| LIN3 DMIC_CLK | Left Input #3 for ACS422ATAG Digital Mic Clock for ACS422DTAG | I(Analog) | None | 9 | 8 |
| RIN3 DMIC_DAT | Right Input #3 for ACS422ATAG Digital Mic Data for ACS422DTAG | I(Analog) | None | 8 | 7 |

Table 91. Analog Input Pins

Total Pins: 6

9.5.4. Analog Output Pins

| Pin Name | Pin Function | I/O | Internal Pull-up Pull-down | TLA Pin location | QFN Pin location |
|------------|---------------------------|-----------|-------------------------------|---------------------|---------------------|
| HP_L | Headphone output | O(Analog) | None | 55 | 38 |
| HP_R | Headphone output | O(Analog) | None | 54 | 37 |
| Class D L+ | BTL Left positive output | O(Analog) | None | 49 | 33 |
| Class D L- | BTL Left negative output | O(Analog) | None | 48 | 32 |
| Class D R+ | BTL Right positive output | O(Analog) | None | 43 | 28 |
| Class D R- | BTL Right negative output | O(Analog) | None | 42 | 29 |

Table 92. Analog Output Pins

Total Pins: 6

9.5.5. Data and Control Pins

| Pin Name | Pin Function | I/O | Internal Pull-up Pull-down | TLA Pin location | QFN Pin location |
|----------|------------------------------------|--------------|-------------------------------|---------------------|---------------------|
| ADCBCLK | ADC I ² S shift clock | I/O(Digital) | Pull-Down | 16 | 15 |
| ADCLRCLK | ADC I ² S framing clock | I/O(Digital) | Pull-Down | 17 | 14 |
| ADCDOUT | ADC I ² S output data | O(Digital) | Pull-Down | 18 | 18 |
| DACBCLK | DAC I ² S shift clock | I/O(Digital) | Pull-Down | 13 | 11 |
| DACLRCLK | DAC I ² S framing clock | I/O(Digital) | Pull-Down | 14 | 12 |
| DACDIN | DAC I ² S input data | I(Digital) | Pull-Down | 15 | 13 |
| I2C_SCL | SCL I ² C shift clock | I(Digital) | Pull-Up | 19 | 16 |
| I2C_SDA | SDA I ² C shift data | I(Digital) | Pull-Up | 20 | 17 |
| HP_DET | Headphone jack detection | I(Digital) | Pull-Up | 52 | 35 |
| TEST | Reserved test pin | I(Analog) | None | 39 | - |

Table 93. Data and Control Pins

Total Pins: 10

ACS422x67

LOW-POWER, HIGH-FIDELITY, INTEGRATED CODEC

9.5.6. Clock Pins

| Pin Name | Pin Function | I/O | Internal Pull-up Pull-down | TLA Pin location | QFN Pin location |
|--------------|-------------------------------|------------|-------------------------------|---------------------|---------------------|
| MCLK/XTAL_IN | Master Clock or Crystal input | I(XTAL) | None | 34 | 22 |
| XTAL_OUT | Crystal output | O(XTAL) | None | 33 | 23 |
| REF_OUT | Buffered crystal clock output | O(Digital) | Pull-Down | 35 | NC |
| NC | No Connect | NC | NC | 22-30 | - |

Table 94. Clock Pins

Total Pins: 12

10. PACKAGE INFORMATION

10.1. QFN Package Drawing

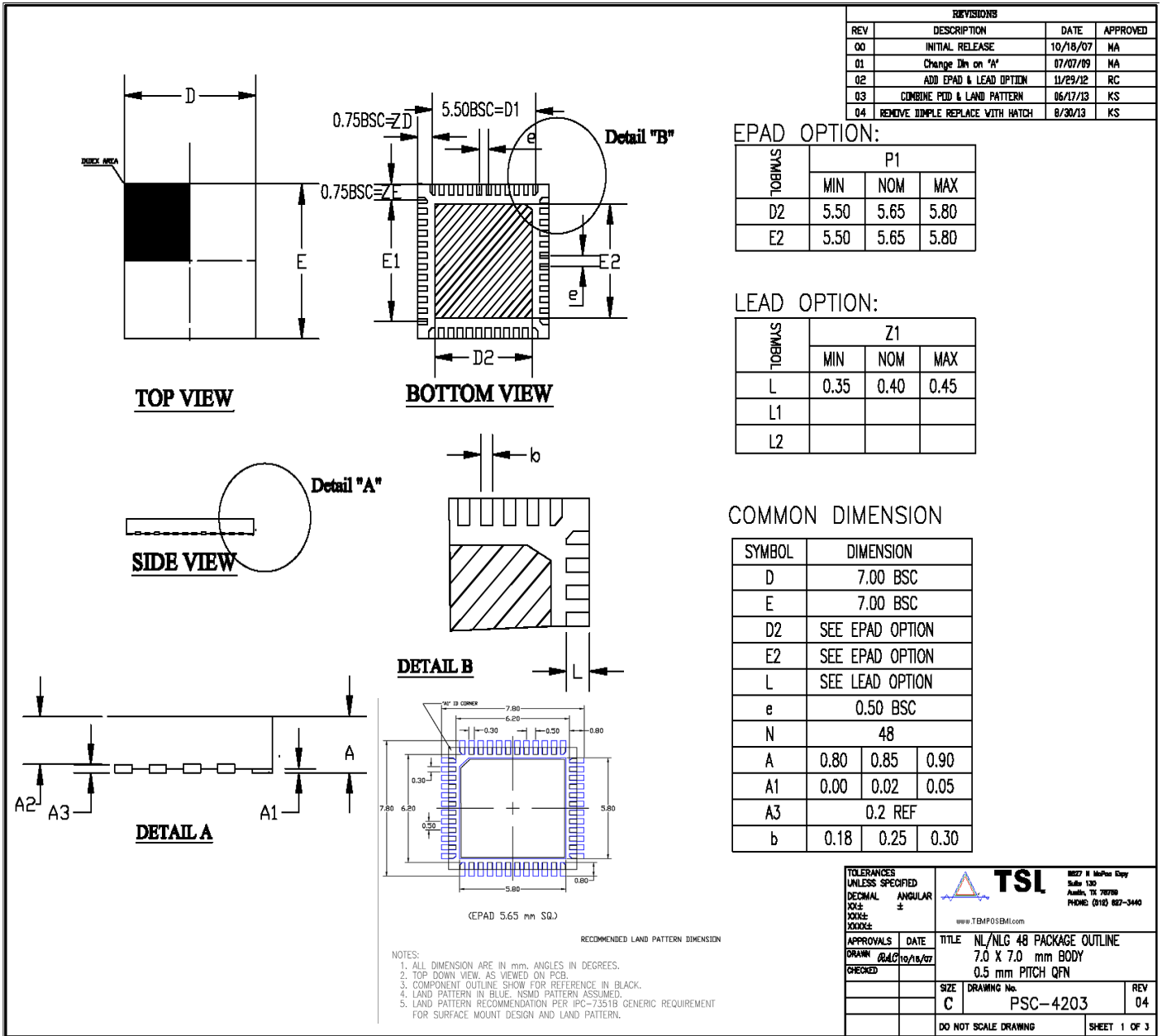
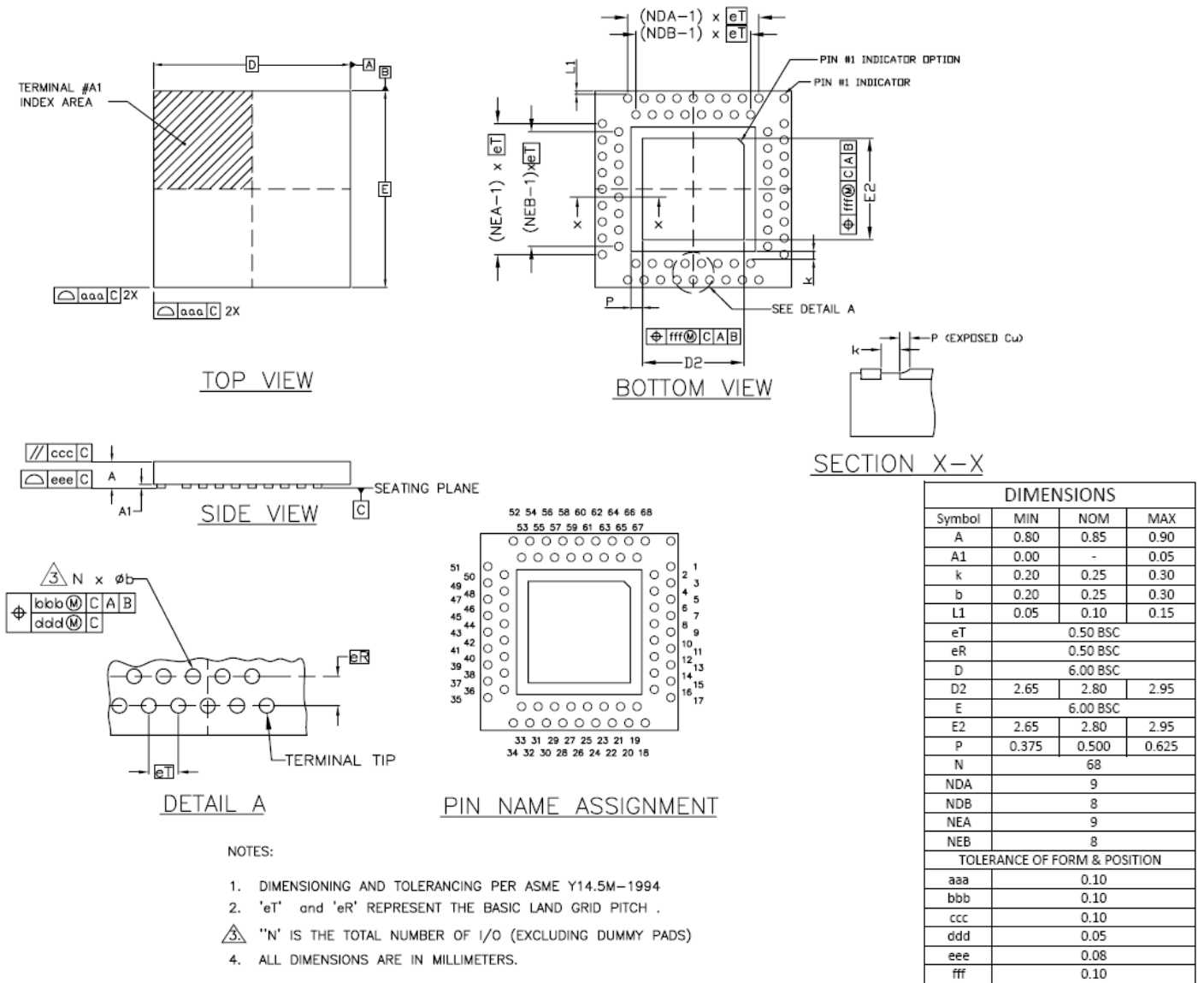

Figure 34. Package Outline

10.2. TAG/TLA Package Drawing



NOTES:

1. DIMENSIONING AND TOLERANCING PER ASME Y14.5M-1994
2. 'eT' and 'eR' REPRESENT THE BASIC LAND GRID PITCH .
3. "N" IS THE TOTAL NUMBER OF I/O (EXCLUDING DUMMY PADS)
4. ALL DIMENSIONS ARE IN MILLIMETERS.

Note: To create a thermal pad size follow "D2" and "E2" value. Ignore "P" and "k"

Figure 35. Package Outline

10.3. Pb Free Process- Package Classification Reflow Temperatures

| Package Thickness | Volume mm ³ <350 | Volume mm ³ 350 - 2000 | Volume mm ³ >2000 |
|-------------------|-----------------------------|-----------------------------------|------------------------------|
| <1.6mm | 260 + 0 °C* | 260 + 0 °C* | 260 + 0 °C* |
| 1.6mm - 2.5mm | 260 + 0 °C* | 250 + 0 °C* | 245 + 0 °C* |
| > or = 2.5mm | 250 + 0 °C* | 245 + 0 °C* | 245 + 0 °C* |

*Tolerance: The device manufacturer/supplier shall assure process compatibility up to and including the stated classification temperature (this means Peak reflow temperature +0 °C. For example 260 °C+0 °C) at the rated MSL level.

Table 101. Reflow Temperatures

Note: TSI's package thicknesses are <2.5mm and <350 mm³, so 260 applies in every case.

ACS422x67

LOW-POWER, HIGH-FIDELITY, INTEGRATED CODEC

11. APPLICATION INFORMATION

For application information, please see reference designs and application notes available on www.temposemi.com.

12. ORDERING INFORMATION

| | |
|-----------------|---------------------------------|
| ACS422A67TAGyyX | TLA package, Analog Microphone |
| ACS422D67TAGyyX | TLA package, Digital Microphone |
| ACS422A67NLGyyX | QFN package, Analog Microphone |
| ACS422D67NLGyyX | QFN package, Digital Microphone |

yy = silicon revision, contact TSI for current part number.

13. DISCLAIMER

While the information presented herein has been checked for both accuracy and reliability, manufacturer assumes no responsibility for either its use or for the infringement of any patents or other rights of third parties, which would result from its use. No other circuits, patents, or licenses are implied. This product is intended for use in normal commercial applications. Any other applications, such as those requiring extended temperature range, high reliability, or other extraordinary environmental requirements, are not recommended without additional processing by manufacturer. Manufacturer reserves the right to change any circuitry or specifications without notice. Manufacturer does not authorize or warrant any product for use in life support devices or critical medical instruments.

ACS422x67

LOW-POWER, HIGH-FIDELITY, INTEGRATED CODEC

14. DOCUMENT REVISION HISTORY

| Revision | Date | Description of Change |
|----------|----------------|--|
| 1.0 | October 2011 | initial release |
| 1.1 | January 2012 | Corrected the I/O type for the Analog output pins. Corrected the pin location in Analog output pin table for the BTL outputs. |
| 1.2 | September 2012 | Clarifications to MCLK/XTAL and REFOUT rate. Updated PLL Electrical characteristics. |
| 1.3 | October 2012 | Corrected HP_L and HP_R pin location in pin table to match the pin diagram. |
| 1.4 | November 2012 | Removed typical and low power consumption tables from electricals section, since these metrics are driven by software settings and are system specific, the typicals listed were not representative of what can be expected of the device. |
| 1.5 | August 2013 | Updated Recommended Operating Condition Max for PVDD from 5.25V to 5.5V. |
| 1.6 | October 2014 | Released in TSI format |
| 1.7 | July 2015 | Additional package option |



www.temposemi.com
8627 N. MoPac Expwy Suite 130
Austin, Texas 78759

DISCLAIMER Tempo Semiconductor, Inc. (TSI) and its subsidiaries reserve the right to modify the products and/or specifications described herein at any time and at TSI's sole discretion. All information in this document, including descriptions of product features and performance, is subject to change without notice. Performance specifications and the operating parameters of the described products are determined in the independent state and are not guaranteed to perform the same way when installed in customer products. The information contained herein is provided without representation or warranty of any kind, whether express or implied, including, but not limited to, the suitability of TSI's products for any particular purpose, an implied warranty of merchantability, or non-infringement of the intellectual property rights of others. This document is presented only as a guide and does not convey any license under intellectual property rights of TSI or any third parties.

TSI's products are not intended for use in life support systems or similar devices where the failure or malfunction of an TSI product can be reasonably expected to significantly affect the health or safety of users. Anyone using an TSI product in such a manner does so at their own risk, absent an express, written agreement by TSI.

Tempo Semiconductor, TSI and the TSI logo are registered trademarks of TSI. Other trademarks and service marks used herein, including protected names, logos and designs, are the property of TSI or their respective third party owners.

Copyright 2014. All rights reserved.



**Стандарт
Электрон
Связь**

Мы молодая и активно развивающаяся компания в области поставок электронных компонентов. Мы поставляем электронные компоненты отечественного и импортного производства напрямую от производителей и с крупнейших складов мира.

Благодаря сотрудничеству с мировыми поставщиками мы осуществляем комплексные и плановые поставки широчайшего спектра электронных компонентов.

Собственная эффективная логистика и склад в обеспечивает надежную поставку продукции в точно указанные сроки по всей России.

Мы осуществляем техническую поддержку нашим клиентам и предпродажную проверку качества продукции. На все поставляемые продукты мы предоставляем гарантию .

Осуществляем поставки продукции под контролем ВП МО РФ на предприятия военно-промышленного комплекса России , а также работаем в рамках 275 ФЗ с открытием отдельных счетов в уполномоченном банке. Система менеджмента качества компании соответствует требованиям ГОСТ ISO 9001.

Минимальные сроки поставки, гибкие цены, неограниченный ассортимент и индивидуальный подход к клиентам являются основой для выстраивания долгосрочного и эффективного сотрудничества с предприятиями радиоэлектронной промышленности, предприятиями ВПК и научно-исследовательскими институтами России.

С нами вы становитесь еще успешнее!

Наши контакты:

Телефон: +7 812 627 14 35

Электронная почта: sales@st-electron.ru

Адрес: 198099, Санкт-Петербург,
Промышленная ул, дом № 19, литера Н,
помещение 100-Н Офис 331