

Click [here](#) for production status of specific part numbers.

MAX31342

Low-Current, Real-Time Clock with I²C Interface

General Description

The MAX31342 low-current, real-time clock (RTC) is a time-keeping device that provides an extremely low time-keeping current, permitting longer life from a power supply. The MAX31342 supports 6pF high-ESR crystals, which broaden the pool of usable crystals for the devices. This device is accessed through an I²C serial interface. An integrated power-on reset function ensures deterministic default register status upon power-up.

Other features include two time-of-day alarms, interrupt outputs, a programmable square-wave output, and a serial bus timeout mechanism. The clock/calendar provides seconds, minutes, hours, day, date, month, and year information. The date at the end of the month is automatically adjusted for months with fewer than 31 days, including corrections for leap year. The clock operates in 24-hour mode. The MAX31342 also includes an input for synchronization. When a reference clock (e.g., 32kHz, 50Hz/60Hz Power Line, GPS 1PPS) is present at the CLKIN pin and the enable external clock input bit (ECLK) is set to 1, the MAX31342 RTC is frequency-locked to the external clock and the clock accuracy is determined by the external source.

The device is available in lead(Pb)-free/RoHS-compliant, 8-pin wafer-level package (WLP) 1mm x 2mm package with 0.5mm pitch. The device supports the -40°C to +85°C extended temperature range.

Applications

- Medical
- Wearables
- Point-of-Sale (POS)
- Telematics
- Portable Instruments
- Portable Audio
- Power Meters

Benefits and Features

- Increases Battery Life
 - 150nA Timekeeping Current
 - Wide Range of External Crystals with $C_L = 6\text{pF}$ and ESR up to 100k Ω for Minimal Current Draw
- Provides Flexible Configurability
 - Programmable Square Wave Output for Clock Monitoring
- Saves Board Space
 - Integrated Load Capacitors for Crystal Oscillator
 - 1mm x 2mm, 8-Bump WLP with 0.5mm Pitch
- Value Add Features for Ease of Use
 - +1.6V to +3.6V Operating Voltage Range
 - Countdown Timer with Repeat Function
- Integrated Protection
 - Power-On Reset for Default Configuration
 - Lockup-Free Operation with Bus Timeout

[Ordering Information](#) appears at end of data sheet.

Typical Operating Circuit

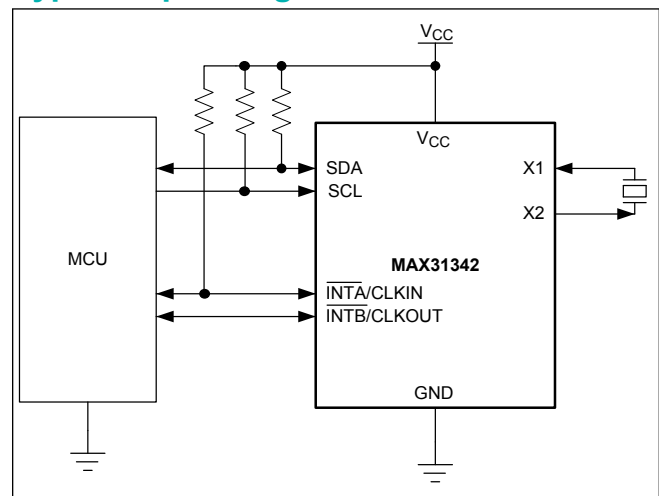

Absolute Maximum Ratings

Voltage Range on Any Pin Relative to Ground	-0.3V to +6V	Soldering Temperature	See the IPC/JEDEC J-STD-020A Specification
Operating Temperature Range	-40°C to +85°C		
Junction Temperature	+150°C		
Storage Temperature Range	-55°C to +150°C		

Stresses beyond those listed under "Absolute Maximum Ratings" may cause permanent damage to the device. These are stress ratings only, and functional operation of the device at these or any other conditions beyond those indicated in the operational sections of the specifications is not implied. Exposure to absolute maximum rating conditions for extended periods may affect device reliability.

Package Information

8 WLP

Package Code	W80D1-1
Outline Number	21-100291
Land Pattern Number	Refer to Application Note 1891
Thermal Resistance, Four-Layer Board:	
Junction-to-Ambient (θ_{JA})	49°C/W
Junction-to-Case Thermal Resistance (θ_{JC})	N/A

For the latest package outline information and land patterns (footprints), go to www.maximintegrated.com/packages. Note that a "+", "#", or "-" in the package code indicates RoHS status only. Package drawings may show a different suffix character, but the drawing pertains to the package regardless of RoHS status.

Package thermal resistances were obtained using the method described in JEDEC specification JESD51-7, using a four-layer board. For detailed information on package thermal considerations, refer to www.maximintegrated.com/thermal-tutorial.

Electrical Characteristics

(V_{CC} = +1.6V to +3.6V, typical values at V_{CC} = +3.0V, unless otherwise noted. Limits are 100% tested at T_A = +25°C, unless otherwise noted. Limits over the operating temperature range, and relevant supply voltage range, are guaranteed by design and characterization (Note 1).)

PARAMETER	SYMBOL	CONDITIONS	MIN	TYP	MAX	UNITS
DC CHARACTERISTICS						
Operating Voltage Range	V _{CC}	Full operation (Note 2)	1.6		3.6	V
Minimum Timekeeping Voltage	V _{CC} TMIN	T _A = +25°C (Note 2) (Note 3)		1		V
Timekeeping Current: CLKIN = GND or CLKIN = V _{CC} (Note 3)	I _{CC} T	V _{CC} = +1.6V		130	300	nA
		V _{CC} = +3.0V		150	330	
Maximum Supply Voltage Rise Slew Rate	T _{VCCR}			3		V/μs
Data Retention Current (Oscillator Stopped and I ² C Inactive)	I _{BATDR}	T _A = +25°C		6		nA
ESD Protection (All Pins)		Human Body Model (HBM)		±2.5		kV
LOGIC INPUTS and OUTPUTS						
Logic 1 Input	V _{IH}	(Note 2)	0.7 x V _{CC}		V _{CC} + 0.3	V
Logic 0 Input	V _{IL}	(Note 2)	-0.3		+0.3 x V _{CC}	V
Input Leakage (SCL, CLKIN/INTA)	I _{IL}	Input clock enabled	-0.1		+0.1	μA
Output Leakage (CLKIN/INTA, CLKOUT/INTB)	I _O	Input clock disabled	-1.0		+1.0	μA
Output Logic 1 V _{OH} = +1.0V (CLKOUT/INTB)	I _{OH}	V _{CC} ≥ 1.6V	-1.0			mA
Output Logic 0, V _{OL} = +0.4V (SDA, CLKIN/INTA, CLKOUT/INTB)	I _{OL}	V _{CC} ≥ 1.6V	2.0			mA
I²C INTERFACE						
SCL Clock Frequency	f _{SCL}	(Note 4) (Note 10)	10		400	kHz
Bus Free Time Between a STOP and START Condition	t _{BUF}		1.3			μs
Hold Time (Repeated) START Condition	t _{HD:STA}	(Note 5)	0.6			μs
Low Period of SCL Clock	t _{LOW}		1.3			μs
High Period of SCL Clock	t _{HIGH}		0.6			μs
Data Hold Time	t _{HD:DAT}	(Note 6) (Note 7)	0		0.9	μs

Electrical Characteristics (continued)

($V_{CC} = +1.6V$ to $+3.6V$, typical values at $V_{CC} = +3.0V$, unless otherwise noted. Limits are 100% tested at $T_A = +25^{\circ}C$, unless otherwise noted. Limits over the operating temperature range, and relevant supply voltage range, are guaranteed by design and characterization (Note 1).)

PARAMETER	SYMBOL	CONDITIONS	MIN	TYP	MAX	UNITS
Data Setup Time	$t_{SU:DAT}$	$V_{CC} = 3V$. (Note 8)	100			ns
Setup Time for a Repeated, START Condition	$t_{SU:STA}$		0.6			μs
Minimum Rise Time of Both SDA and SCL Signals	t_R	(Note 9)		20 + 0.1 C_B		ns
Maximum Rise Time of Both SDA and SCL Signals	t_R			300		ns
Minimum Fall Time for Both SDA and SCL Signals	t_F	(Note 9)		20 + 0.1 C_B		ns
Maximum Fall Time for Both SDA and SCL Signals	t_F			300		ns
Setup Time for STOP Condition	$t_{SU:STO}$		0.6			μs
Maximum Capacitive Load for Each Bus Line	C_B	(Note 9)		400		pF
I/O Capacitance	$C_{I/O}$			10		pF
SCL Spike Suppression	t_{SP}			30		ns
Oscillator Stop Flag (OSF) Delay	t_{OSF}	(Note 11)		35	100	ms
Timeout Interval	$t_{TIMEOUT}$	(Note 12)	25		35	ms

Note 1: Limits at $-40^{\circ}C$ and $85^{\circ}C$ are guaranteed by design; not production tested.

Note 2: Voltage referenced to ground.

Note 3: Specified with I²C bus inactive. Oscillator operational.

Note 4: The minimum SCL clock frequency is limited by the bus timeout feature, which resets the serial bus interface if SCL is held low for $t_{TIMEOUT}$.

Note 5: After this period, the first clock pulse is generated.

Note 6: A device must internally provide a hold time of at least 300ns for the SDA signal (referred to the V_{IHMIN} of the SCL signal) to bridge the undefined region of the falling edge of SCL.

Note 7: The maximum $t_{HD:DAT}$ need only be met if the device does not stretch the low period (t_{LOW}) of the SCL signal.

Note 8: A fast-mode device can be used in a standard-mode system, but the requirement $t_{SU:DAT} \geq 250ns$ must then be met. This is automatically the case if the device does not stretch the low period of the SCL signal. If such a device does stretch the low period of the SCL signal, it must output the next data bit to the SDA line $t_{RMAX} + t_{SU:DAT} = 1000 + 250 = 1250ns$ before the SCL line is released.

Note 9: C_B is the total capacitance of one bus line, including all connected devices, in pF.

Note 10: Guaranteed by design; not 100% production tested.

Note 11: The parameter t_{OSF} is the period of time the oscillator must be stopped for the OSF flag to be set over the voltage range of $2.4V \leq V_{CC} \leq V_{CCMAX}$.

Note 12: The MAX31342 can detect the SCL clock low signal longer than the $t_{TIMEOUT}$. When this occurs, the device I²C interface is in reset state. Once the device detects a START condition where SCL is held low shorter than $t_{TIMEOUT}$, it exits out of reset and SDA output is released. The oscillator must be running for this function to work.

Electrical Characteristics—Crystal Parameters

(V_{CC} = +1.6V to +3.6V, typical values at V_{CC} = +3.0V, AIN threshold voltage at V_{TH1} = 1.4V, unless otherwise noted. Limits are 100% tested at T_A = +25°C. Note 1.)

PARAMETER	SYMBOL	CONDITIONS	MIN	TYP	MAX	UNITS
Nominal Frequency	f _O	Recommended value for external crystal		32.768		kHz
Maximum Series Resistance	ESR	Recommended value for external crystal		100		kΩ
Load Capacitance	C _L			6		pF

Typical Operating Characteristics

(V_{CC} = 3.0V; T_A = +25°C, unless noted otherwise.)

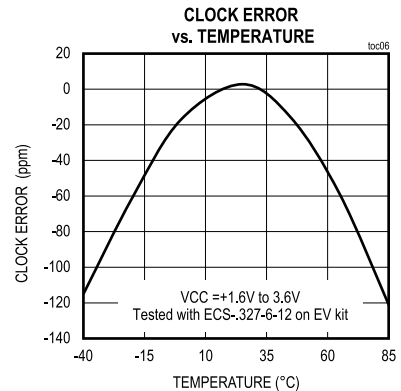
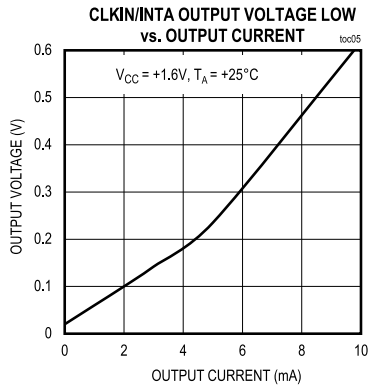
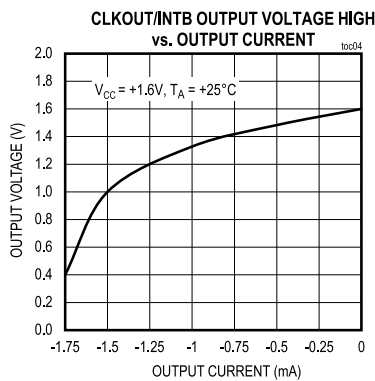
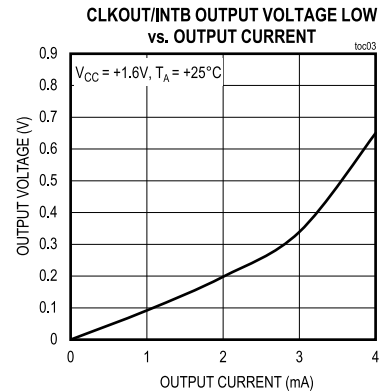
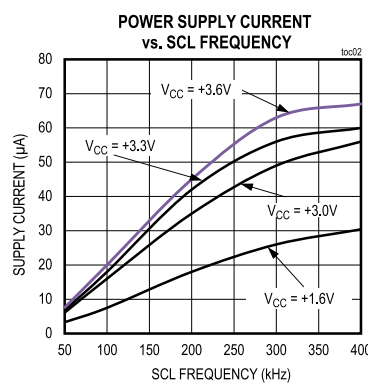
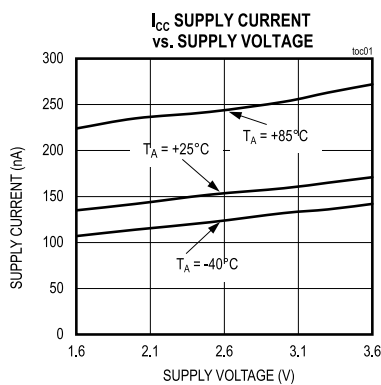

Pin Configuration

8 WLP

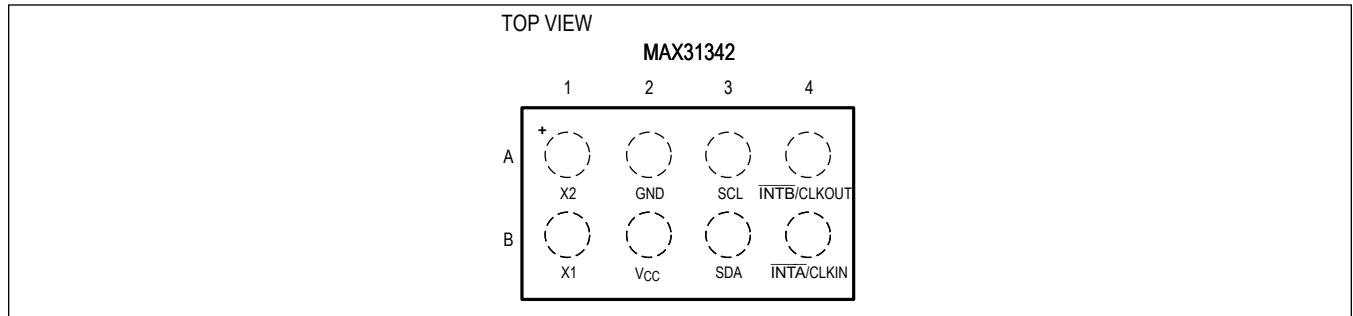

Pin Description

PIN	NAME	FUNCTION
A1	X2	Second Crystal Input for an External 32.768kHz Crystal with 6pF Load Capacitance.
A2	GND	Ground
A3	SCL	Serial-Clock Input. SCL is used to synchronize data movement on the serial interface. The SCL pin is open-drain and requires an external pullup resistor.
A4	INTB/CLKOUT	Square-Wave Clock or Active-Low Interrupt Output. This pin is used to output a programmable square wave or an alarm interrupt signal. This is a CMOS push-pull output and does not require an external pullup resistor. If not used, this pin can be left unconnected. See Table 1 for details.
B1	X1	First Crystal Input for an External 32.768kHz Crystal with 6pF Load Capacitance.
B2	V _{CC}	Supply Voltage
B3	SDA	Serial-Data Input/Output. SDA is the input/output pin for the I ² C serial interface. The SDA pin is open-drain and requires an external pullup resistor.
B4	INTA/CLKIN	Clock Input/Active-Low Interrupt Output. This I/O pin is used to output an alarm interrupt or accept an external clock input to drive the RTC counter. In the output mode, this is an open-drain and requires an external pullup resistor. If not used, connect this pin to ground. See Table 1 for details.

Functional Diagram

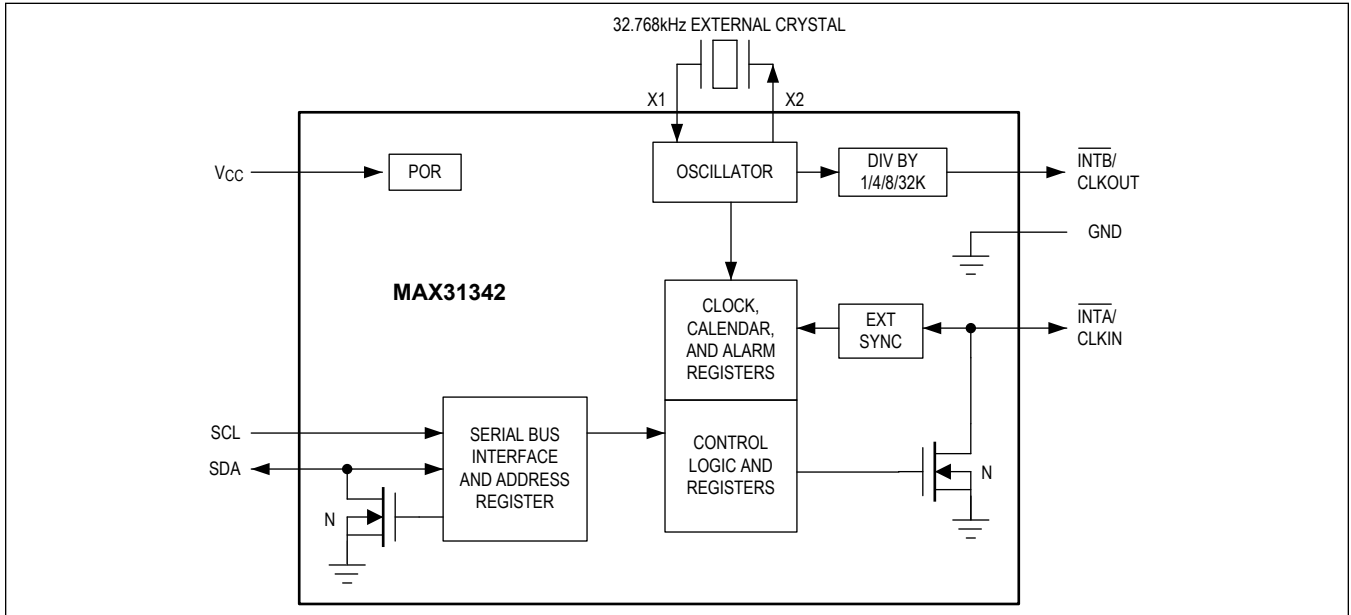

Detailed Description

Introduction

The MAX31342 low-current RTC are timekeeping devices that consume an extremely low timekeeping current, permitting longer battery life. The clock/calendar provides seconds, minutes, hours, day, date, month, and year information. The date at the end of the month is automatically adjusted for each month with fewer than 31 days, including corrections for leap year through 2199. The clock operates in 24-hour mode.

The MAX31342 is accessed through an I²C serial interface. An integrated power-on reset function ensures deterministic default register status upon power-up. However, a soft reset command should be issued after a brownout or a short blackout to properly reset the MAX31342. Other features include two time-of-day alarms, two interrupts, a programmable square-wave output, and a bus timeout mechanism that resets the I²C bus if it remains inactive for a minimum of t_{TIMEOUT} .

The MAX31342 uses an external 32.768kHz crystal. The oscillator circuit does not require any external resistors or capacitors to operate. The device supports a high-ESR crystal, which broadens the pool of usable crystals for the device. The MAX31342 uses a 6pF crystal, which decreases oscillator current draw. The MAX31342 also accepts an external clock reference for synchronization. The external clock can be a 32.768kHz, 50Hz, 60Hz, or 1Hz source. When the enable oscillator bit (OSCONZ) is a 0, the MAX31342 uses the oscillator for timekeeping. If the enable external clock input bit (ECLK) is set to 1, the time base derived from the oscillator is compared to the 1Hz signal that is derived from the CLKIN signal. The conditioned signal drives the RTC time and date counters. When the external clock is lost or when the frequency differs more than $\pm 0.8\%$ from the crystal frequency, the LOS flag is asserted.

The time and calendar information is obtained by reading the appropriate register bytes after the Rd_RTC bit is set. The Register Map shows the RTC registers. The time and calendar data are set or initialized by writing the appropriate register bytes followed by a SET_RTC bit of Config_reg2 register transition from 0 to 1. The contents of the time and calendar registers are in the binary-coded decimal (BCD) format. The device runs in 24-hour mode. The century bit (bit 7 of the Month register) is toggled when the Years register overflows from 99 to 00. The day-of-week register increments at midnight. Values that correspond to the day of week are user-defined but must be sequential (i.e., if 1 equals Sunday, then 2 equals Monday, and so on). Illogical time and date entries result in undefined operation. When reading or writing the time and date registers, secondary buffers are used to prevent errors when the internal registers update. When reading the time and date registers, the secondary buffers are synchronized to the internal registers on any I²C START and when the register pointer rolls over to zero. The time information is read from these secondary registers, while the clock continues to run. This eliminates the need to reread the registers in case the main registers update during a read.

The MAX31342 is available in lead (Pb)-free/RoHS-compliant, 8-bump WLP with 0.5mm pitch, and supports the -40°C to $+85^{\circ}\text{C}$ extended temperature range.

I²C Interface

Address and data are transferred serially through an I²C serial interface. The I²C interface is guaranteed to operate when V_{CC} is between 1.6V and 3.6V. The I²C interface is accessible whenever V_{CC} is at a valid level. To prevent invalid device operation, the I²C interface should not be accessed when V_{CC} is below 1.6V. The slave address is defined as the 7 most significant bits (MSBs) sent by the master after a START condition. The address is 0xD2 (left justified with LSB set to 0). The eighth bit is used to define a write or read operation.

If a microcontroller connected to the MAX31342 resets during I²C communications, it is possible that the microcontroller and the MAX31342 could become unsynchronized. When the microcontroller resets, the MAX31342 I²C interface can be placed into a known state by holding SCL low for t_{TIMEOUT} . Doing so limits the minimum frequency at which the I²C interface can be operated. If data is being written to the device when the interface timeout is exceeded, prior to the acknowledge, the incomplete byte of data is not written.

Burst read/write allows the controller to read/write multiple consecutive bytes from a device. It is initiated in the same manner as the byte read/write operation, but instead of terminating the read/write cycle after the first data byte is transferred, the controller can read/write to the whole register array. In burst write operation, after the receipt of each

byte, the device responds with an acknowledge, and the address is internally incremented by one. When the address pointer reaches the end of the register address list, it goes back to the first register address. In burst read mode, the controller responds with an acknowledge, indicating it waits for additional data. The device continues to output data for each acknowledge received. The controller terminates the read operation by not responding with an acknowledge and issuing a STOP condition.

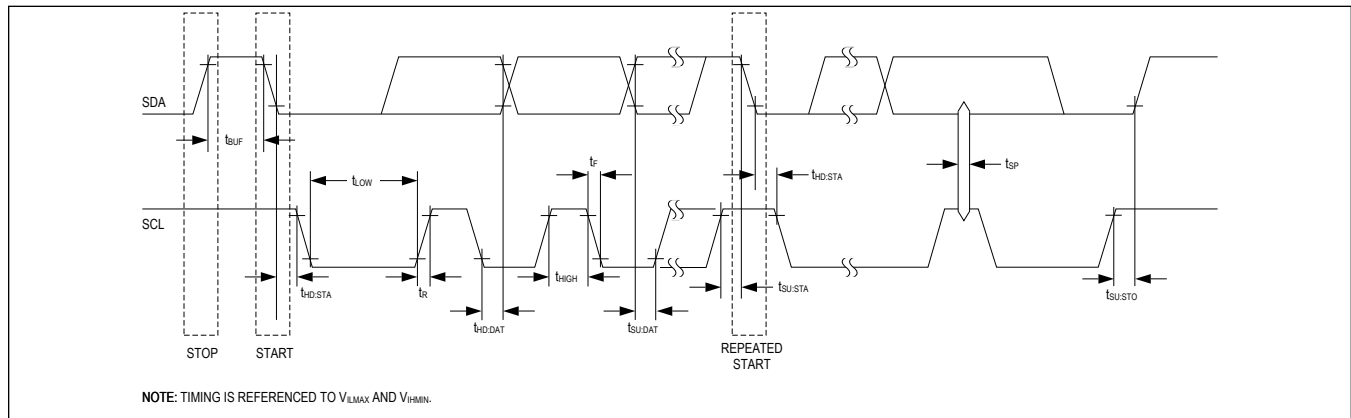

Figure 1. Data Transfer on I²C Serial Bus

RTC Startup Process

Use the following procedure to enable RTC and set time.

1. Exit software reset and enable oscillator (SWRSTN = 1 and OSCONZ = 0) in register Config_reg1 (0x00).
2. Write RTC time to registers 0x06-0x0C.
3. Write SET_RTC = 1 in register Config_reg2 (0x01).
4. Wait 10ms.
5. Write SET_RTC = 0 in register Config_reg2 (0x01).

Oscillator Circuit

The MAX31342 uses an external 32.768kHz crystal. The oscillator circuit does not require any external resistors or capacitors to operate. The MAX31342 includes integrated capacitive loading for a 6pF C_L crystal. See the [Electrical Characteristics](#) table for the external crystal parameters. The startup time of the oscillator circuit is usually less than 1 second when using a crystal with the specified characteristics. An additional 4s are needed for the chip to reach stable, low-current operation.

Clock Accuracy

When running from the internal oscillator, the accuracy of the clock is dependent upon the accuracy of the crystal and the accuracy of the match between the capacitive load of the oscillator circuit and the capacitive load for which the crystal was trimmed. Additional error is added by crystal frequency drift caused by temperature shifts. External circuit noise coupled into the oscillator circuit can result in the clock running fast. [Figure 2](#) and [Figure 3](#) show a typical PCB layout for isolation of the crystal and oscillator from noise. Refer to *Application Note 58: Crystal Considerations with Maxim Real-Time Clocks* on Maxim's website for detailed information.

Layout Example



Figure 2. Top Layer



Figure 3. Bottom Layer

Minimizing the Clock Synchronization Delay

When external clock input is disabled (ECLK = 0), the countdown chain is driven by internal high-speed clock. The output of the countdown chain is the 1Hz clock that drives the RTC logic. By default, Clk_sync_reg (58h) = 0x02 and the countdown chain is reset whenever the Set_RTC transitions from 0 to 1. That means after Set_RTC becomes 1, RTC registers (06h – 0Ch) will transfer to internal RTC counter and the next RTC update will happen 1 second later with less than 10ms synchronization delay. If external clock (50Hz/60Hz/32KHz) is used, set Clk_sync_reg = 0x01 to minimize the synchronization delay to less than 100ms. If external 1Hz clock is used, set Clk_sync_reg = 0x00. The maximum synchronization delay will be 1s.

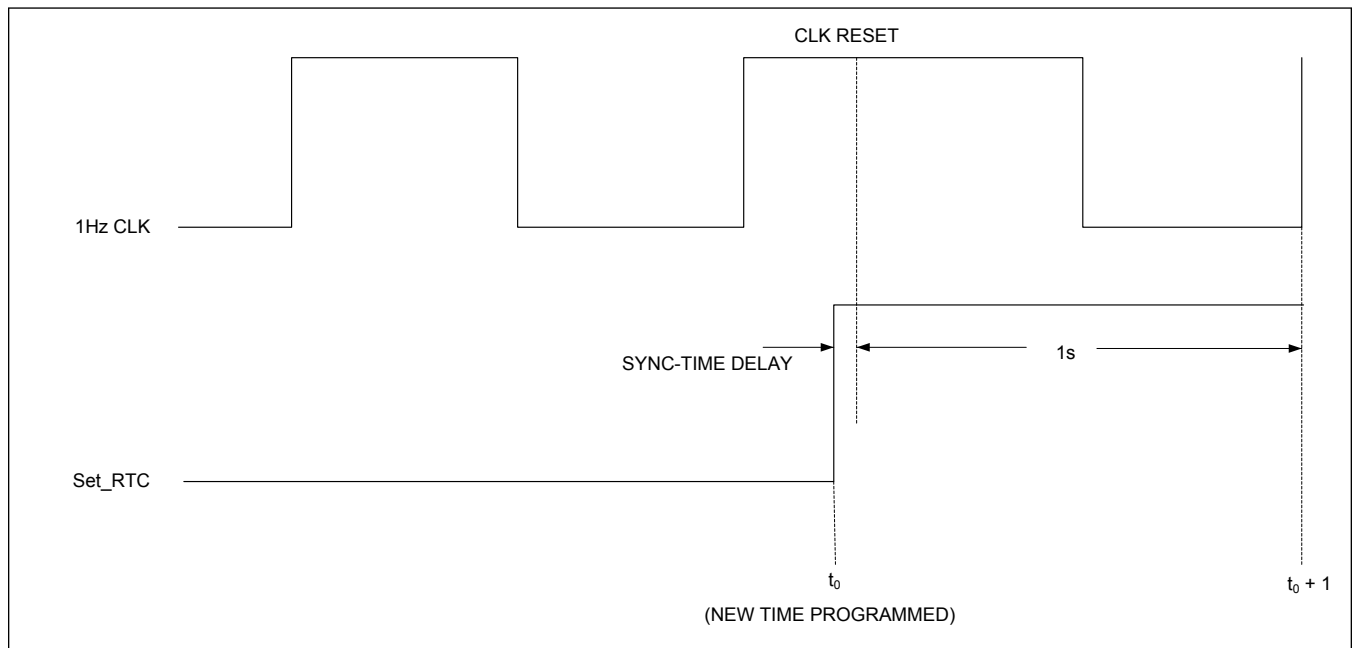

Figure 4. Clock Synchronization Delay

Interrupts Status and Output

When an interrupt is asserted, the interrupt output pin changes from high to low, and all its corresponding registers will update after 2ms. That includes the Int_status_reg(05h). The Interrupt status bit and output can be cleared by reading the Int_status_reg. Pin INTB/CLKOUT corresponds to Alarm2, while pin INTA/CLKIN corresponds to Alarm1, and D1 and AIN interrupts. Interrupt mode can be set based on [Table 1](#).

Table 1. Interrupt Modes

INTCN	ECLK	INTA/CLKIN	INTB/CLKOUT
0	0	INTA: Alarm1, Alarm2, Timer	CLKOUT
0	1	CLKIN	CLKOUT
1	0	INTA: Alarm1, Timer	INTB: Alarm2
1	1	CLKIN	INTB: Alarm1, Alarm2, Timer

Data Retention Mode

The MAX31342 features a Data Retention mode wherein the device shuts down its internal functional blocks (including the oscillator) except the I²C interface. The device consumes 6nA (typ) in this mode. It retains all the register contents, including the last valid date and time values. The device can resume counting from here when this mode is exited and the oscillator is enabled again.

Procedure to Enter Data Retention Mode:

1. Write DATA_RETEN = 1 in Config_reg2 (01h)
2. Write OSCONZ = 1 in Config_reg1 (00h)

Procedure to Exit Data Retention Mode:

1. Write DATA_RETEN = 0 in Config_reg2 (01h)
2. Write OSCONZ = 0 in Config_reg1 (00h)

Countdown Timer

The MAX31342 features a countdown timer with a pause function. The timer can be configured by writing into registers 03h (Timer_config) and 17h (Timer_init). The Timer_init register should be loaded with the initial value from which the timer would start counting down. The Timer_config register allows these configuration options:

- Select the frequency of the timer using the TFS[1:0] field.
- Start/stop the timer using the TE (Timer Enable) bit.
- Enable/disable the timer repeat function using the TRPT bit. This function reloads and restarts the timer with the same init value once it counts down to zero. In repeat mode, the first timer interrupt indicates the timer has started counting.
- Pause/resume the countdown at any time when the timer is enabled using the TPAUSE bit (explained below).

The timer can be programmed to assert the $\overline{\text{INTA}}$ or $\overline{\text{INTB}}$ output (see [Table 2](#)) whenever it counts down to zero. This can be enabled/disabled using the TIE bit in register 04h (Int_en_reg).

The TPAUSE bit is only valid when TE = 1. This bit must be reset to 0 whenever TE is reset to 0.

The table below highlights the steps to be used for various use cases involving TE and TPAUSE.

Table 2. Countdown Timer Sequence

SEQUENCE	TE	TPAUSE	ACTION
Step 1	0	0	Countdown timer is reset, and ready for next countdown operation. Timer_init can be programmed in this state.
Step 2	1	0	Countdown timer starts counting down from the value programmed in Timer_init
Step 3a (Optional)	1	1	Countdown timer is paused, and is ready to start counting down when TPAUSE is programmed back to '0'. Contents of the countdown timer are preserved in this state.
Step 3b If 3a is true	1	0	Countdown timer is brought out of pause state, and starts counting down from the paused value.
—	0	1	Not allowed

Typical use cases:

- Countdown timer without pause: Step 1, Step 2, Step 1, and so on.
- Countdown timer with pause: Step 1, Step 2, Step 3a, Step 3b, Step 1, and so on.

Register Map

Register Map

ADDRESS	NAME	MSB							LSB
REGBLK									
0x00	Config_reg1[7:0]	ECLK	INTCN	CLKSEL[1:0]		OSCON_Z	RS[1:0]		SWRST_N
0x01	Config_reg2[7:0]	-	DATA_RETEN	-	-	I2C_TIME_OUT_EN	Rd_RTC	Set_RTC	-
0x03	Timer_config[7:0]	-	-	TPAUSE	TE	-	TRPT	TFS[1:0]	
0x04	Int_en_reg[7:0]	-	DOSF	-	-	-	TIE	A2IE	A1IE
0x05	Int_status_reg[7:0]	LOS	OSF	-	-	-	TIF	A2F	A1F
0x06	Seconds[7:0]	-	sec_10[2:0]			seconds[3:0]			
0x07	Minutes[7:0]	-	min_10[2:0]			minutes[3:0]			
0x08	Hours[7:0]	-	Reserved	hr_10[1:0]		hour[3:0]			
0x09	Day[7:0]	-	-	-	-	-	day[2:0]		
0x0A	Date[7:0]	-	-	date_10[1:0]		date[3:0]			
0x0B	Month[7:0]	century	-	-	month_10	month[3:0]			
0x0C	Year[7:0]	year_10[3:0]				year[3:0]			
0x0D	Alm1_sec[7:0]	A1M1	sec_10[2:0]			seconds[3:0]			
0x0E	Alm1_min[7:0]	A1M2	min_10[2:0]			minutes[3:0]			
0x0F	Alm1_hrs[7:0]	A1M3	Reserved	hr_10[1:0]		hour[3:0]			
0x10	Alm1day_date[7:0]	A1M4	DY_DT	date_10[1:0]		day_date[3:0]			
0x11	Alm1_mon[7:0]	A1M5	A1M6	-	month_10	month[3:0]			
0x12	Alm1_year[7:0]	year_10[3:0]				year[3:0]			
0x13	Alm2_min[7:0]	A2M2	min_10[2:0]			minutes[3:0]			
0x14	Alm2_hrs[7:0]	A2M3	Reserved	hr_10[1:0]		hour[3:0]			
0x15	Alm2day_date[7:0]	A2M4	DY_DT	date_10[1:0]		day_date[3:0]			
0x16	Timer_Count[7:0]	Count[7:0]							
0x17	Timer_Init[7:0]	Count[7:0]							
0x58	Clock_sync_reg[7:0]	-	-	-	-	-	-	SYNC_DELAY[1:0]	

Register Details

[Config_reg1 \(0x00\)](#)

Configuration Register

BIT	7	6	5	4	3	2	1	0
Field	ECLK	INTCN	CLKSEL[1:0]		OSCONZ	RS[1:0]		SWRSTN
Reset	0x0	0x0	0x0		0x1	0x3		0x0
Access Type	Write, Read	Write, Read	Write, Read		Write, Read	Write, Read		Write, Read

BITFIELD	BITS	DESCRIPTION	DECODE
ECLK	7	Enable external clock input	0x0: Disable the external clock 0x1: Enable the external clock
INTCN	6	Interrupt control bit. Selects $\overline{\text{INTB}}$ /CLKOUT pin output function	0x0: Output is square wave 0x1: Output is interrupt
CLKSEL	5:4	Selects the CLKIN frequency	0x0: 1Hz 0x1: 50Hz 0x2: 60Hz 0x3: 32.768KHz
OSCONZ	3	Oscillator is on when set to 0. Oscillator is off when set to 1.	0x0: Enable the oscillator 0x1: Disable the oscillator
RS	2:1	Square wave output frequency selection on CLKOUT pin	0x0: 1Hz 0x1: 4.098kHz 0x2: 8.192kHz 0x3: 32.768kHz
SWRSTN	0	Software reset	0x0: Resets the digital block 0x1: Device is not on reset mode

[Config_reg2 \(0x1\)](#)

Configuration Register

BIT	7	6	5	4	3	2	1	0
Field	–	DATA_RETEN	–	–	I2C_TIMEOUT_EN	Rd_RTC	Set_RTC	–
Reset	–	0x0	–	–	0x1	0x1	0x0	–
Access Type	–	Write, Read	–	–	Write, Read	Write, Read	Write, Read	–

BITFIELD	BITS	DESCRIPTION	DECODE
DATA_RETEN	6	Sets the device into data retention mode.	0x0: Normal operation mode 0x1: Data retention mode
I2C_TIMEOUT_EN	3	I ² C timeout enable	0x0: Disables the I ² C timeout 0x1: Enables the I ² C timeout
Rd_RTC	2	Read RTC	0x0: Reads previous programmed RTC value in registers 06h–0Ch 0x1: Reads Current RTC value in registers 06h–0Ch
Set_RTC	1	Set RTC	0 to 1 transition loads RTC registers (06h–0Ch) contents to countdown chain. See <i>Detailed</i>

BITFIELD	BITS	DESCRIPTION	DECODE
			<i>Description</i>

Timer_config (0x3)

Countdown timer configuration register

BIT	7	6	5	4	3	2	1	0
Field	–	–	TPAUSE	TE	–	TRPT	TFS[1:0]	
Reset	–	–	0x0	0x0	–	0x1	0x3	
Access Type	–	–	Write, Read	Write, Read	–	Write, Read	Write, Read	

BITFIELD	BITS	DESCRIPTION	DECODE
TPAUSE	5	Timer Pause. This field is valid only when TE = 1. Reset TPAUSE when TE is reset to 0. See <i>Countdown Timer</i> section.	0x0: Resume timer countdown from paused state 0x1: Pause timer
TE	4	Timer enable	0x0: Timer is reset. New timer countdown value (Timer_Init) can be programmed in this state. Note: TPAUSE must be reset to 0 prior to setting TE to 1. 0x1: Timer enabled countdown starts
TRPT	2	Timer repeat mode	0x0: Countdown timer will halt once it reaches zero 0x1: Countdown timer reloads the value from the Timer_init register upon reaching zero and continues counting.
TFS	1:0	Timer frequency selection	0x0: 1024Hz 0x1: 256Hz 0x2: 64Hz 0x3: 16Hz

Int_en_reg (0x4)

Interrupt Enable register

BIT	7	6	5	4	3	2	1	0
Field	–	DOSF	–	–	–	TIE	A2IE	A1IE
Reset	–	0x0	–	–	–	0x0	0x0	0x0
Access Type	–	Write, Read	–	–	–	Write, Read	Write, Read	Write, Read

BITFIELD	BITS	DESCRIPTION	DECODE
DOSF	6	Disable Oscillator flag	0x0: OSF indicates oscillator status 0x1: Disables the oscillator flag (OSF = 0)
TIE	2	Timer interrupt enable	0x0: Disabled 0x1: Enabled
A2IE	1	Alarm 2 interrupt enable	0x0: Disabled 0x1: Enabled

BITFIELD	BITS	DESCRIPTION	DECODE
A1IE	0	Alarm1 interrupt enable	0x0: Disabled 0x1: Enabled

Int_status_reg (0x5)

Interrupt Status register

BIT	7	6	5	4	3	2	1	0
Field	LOS	OSF	–	–	–	TIF	A2F	A1F
Reset	0x0	0x1	–	–	–	0x0	0x0	0x0
Access Type	Read Clears All	Read Clears All	–	–	–	Read Clears All	Read Clears All	Read Clears All

BITFIELD	BITS	DESCRIPTION	DECODE
LOS	7	Loss of signal. Valid only for external clock modes (ECLK = 1)	0x0: Oscillator clock frequency is within 0.8% of external clock frequency 0x1: Oscillator clock frequency differs more than 0.8% from the external clock frequency
OSF	6	Oscillator stop flag	0x0: Oscillator is running or when DOSF = 1 0x1: Oscillator has stopped
TIF	2	Timer interrupt flag	0x0: Count down timer is not zero 0x1: Countdown timer reached zero
A2F	1	Alarm2 flag	0x0: Alarm2 not triggered 0x1: Alarm2 triggered
A1F	0	Alarm1 flag	0x0: Alarm1 not triggered 0x1: Alarm1 triggered

Seconds (0x6)

Seconds configuration register

BIT	7	6	5	4	3	2	1	0
Field	–	sec_10[2:0]			seconds[3:0]			
Reset	–	0x0			0x0			
Access Type	–	Write, Read			Write, Read			

BITFIELD	BITS	DESCRIPTION
sec_10	6:4	RTC seconds in multiples of 10
seconds	3:0	RTC seconds value.

Minutes (0x7)

Minutes configuration register

BIT	7	6	5	4	3	2	1	0
Field	–	min_10[2:0]			minutes[3:0]			
Reset	–	0x0			0x0			
Access Type	–	Write, Read			Write, Read			

BITFIELD	BITS	DESCRIPTION
min_10	6:4	RTC minutes in multiples of 10
minutes	3:0	RTC minutes value

Hours (0x8)

Hours configuration register

BIT	7	6	5	4	3	2	1	0
Field	–	Reserved	hr_10[1:0]		hour[3:0]			
Reset	–	0x0	0x0		0x0			
Access Type	–	Write, Read	Write, Read		Write, Read			

BITFIELD	BITS	DESCRIPTION
Reserved	6	User must enter 0.
hr_10	5:4	RTC hours in multiples of 10
hour	3:0	RTC hours value

Day (0x9)

Day configuration register

BIT	7	6	5	4	3	2	1	0
Field	–	–	–	–	–	day[2:0]		
Reset	–	–	–	–	–	0x1		
Access Type	–	–	–	–	–	Write, Read		

BITFIELD	BITS	DESCRIPTION
day	2:0	RTC day of the week

Date (0xA)

Date configuration register

BIT	7	6	5	4	3	2	1	0
Field	–	–	date_10[1:0]		date[3:0]			
Reset	–	–	0x0		0x1			
Access Type	–	–	Write, Read		Write, Read			

BITFIELD	BITS	DESCRIPTION
date_10	5:4	RTC date in multiples of 10
date	3:0	RTC date

Month (0xB)

Month configuration register

BIT	7	6	5	4	3	2	1	0
Field	century	–	–	month_10	month[3:0]			
Reset	0x0	–	–	0x0	0x1			
Access Type	Write, Read	–	–	Write, Read	Write, Read			

BITFIELD	BITS	DESCRIPTION	DECODE
century	7	Century bit	0x0: Year is in current century 0x1: Year is in next century
month_10	4	RTC month in multiples of 10	
month	3:0	RTC months	

[Year \(0xC\)](#)

Year configuration register

BIT	7	6	5	4	3	2	1	0
Field	year_10[3:0]				year[3:0]			
Reset	0x0				0x0			
Access Type	Write, Read				Write, Read			

BITFIELD	BITS	DESCRIPTION
year_10	7:4	RTC year multiples of 10
year	3:0	RTC years

[Alm1_sec \(0xD\)](#)

DY_DT	A1M6	A1M5	A1M4	A1M3	A1M2	A1M1	ALARM RATE
x	1	1	1	1	1	1	Once per sec
x	1	1	1	1	1	0	Sec match
x	1	1	1	1	0	0	Min and sec match
x	1	1	1	0	0	0	Hour, min, and sec match
0	1	1	0	0	0	0	Date and Time match
0	1	0	0	0	0	0	Month, Date, and Time match
0	0	0	0	0	0	0	Year, Month, Date, and Time match
1	1	1	0	0	0	0	Day and Time match

Alarm 1 can be set by writing to registers 0Dh - 12h. See Register Map. The alarm can be programmed by the A1IE bit in Int_en_reg (04h) register to activate the INTA/CLKIN output on an alarm match condition. Bit 7 of each of the time-of-day/date alarm registers, and Bit 7 and 6 of month alarm register are mask bits. When all the mask bits of each alarm are logic 0, an alarm only occurs when the values in the timekeeping registers match the corresponding values stored in the time-of-day/date alarm registers. The alarm can also be programmed to repeat every second, minute, hour, day, date, month, or year. The table above shows the possible settings. Configurations not listed in the table result in illogical operation. The DY_DT bit (bit 6 of the alarm day/date registers) controls whether the alarm value stored in bits 0–5 that register reflects the day of the week or the date of the month. If DY_DT is written to logic 0, the alarm is the result of a match with date of the month. If DY_DT is written to logic 1, the alarm is the result of a match with day of the week.

BIT	7	6	5	4	3	2	1	0
Field	A1M1	sec_10[2:0]			seconds[3:0]			
Reset	0x0	0x0			0x0			
Access Type	Write, Read	Write, Read			Write, Read			

BITFIELD	BITS	DESCRIPTION
A1M1	7	Alarm1 mask bit for seconds
sec_10	6:4	Alarm1 seconds in multiples of 10
seconds	3:0	Alarm1 seconds

Alm1_min (0xE)

Alarm1 Minutes configuration register

BIT	7	6	5	4	3	2	1	0
Field	A1M2	min_10[2:0]			minutes[3:0]			
Reset	0x0	0x0			0x0			
Access Type	Write, Read	Write, Read			Write, Read			

BITFIELD	BITS	DESCRIPTION
A1M2	7	Alarm1 mask bit for minutes
min_10	6:4	Alarm1 minutes in multiples of 10
minutes	3:0	Alarm1 minutes

Alm1_hrs (0xF)

Alarm1 Hours configuration register

BIT	7	6	5	4	3	2	1	0
Field	A1M3	Reserved	hr_10[1:0]		hour[3:0]			
Reset	0x0	0x0	0x0		0x0			
Access Type	Write, Read	Write, Read	Write, Read		Write, Read			

BITFIELD	BITS	DESCRIPTION
A1M3	7	Alarm1 mask bit for hours
Reserved	6	User must enter 0.
hr_10	5:4	Alarm1 hours in multiples of 10
hour	3:0	Alarm1 hours

Alm1day_date (0x10)

Alarm1 Day/Date configuration register

BIT	7	6	5	4	3	2	1	0
Field	A1M4	DY_DT	date_10[1:0]		day_date[3:0]			
Reset	0x0	0x0	0x0		0x0			
Access Type	Write, Read	Write, Read	Write, Read		Write, Read			

BITFIELD	BITS	DESCRIPTION	DECODE
A1M4	7	Alarm1 mask bit for day/date	
DY_DT	6		0x0: Alarm when date match 0x1: Alarm when day match
date_10	5:4	Alarm1 date in multiples of 10	
day_date	3:0	Alarm1 day/date	

Alm1_mon (0x11)

Alarm1 Month configuration register

BIT	7	6	5	4	3	2	1	0
Field	A1M5	A1M6	–	month_10	month[3:0]			
Reset	0x1	0x1	–	0x0	0x0			
Access Type	Write, Read	Write, Read	–	Write, Read	Write, Read			

BITFIELD	BITS	DESCRIPTION
A1M5	7	Alarm1 mask bit for month
A1M6	6	Alarm1 mask bit for year
month_10	4	Alarm1 months in multiples of 10
month	3:0	Alarm1 months

Alm1_year (0x12)

Alarm1 Year configuration register

BIT	7	6	5	4	3	2	1	0
Field	year_10[3:0]				year[3:0]			
Reset	0x0				0x0			
Access Type	Write, Read				Write, Read			

BITFIELD	BITS	DESCRIPTION
year_10	7:4	Alarm1 years in multiples of 10
year	3:0	Alarm1 years

Alm2_min (0x13)

DY_DT	A2M4	A2M3	A2M1	ALARM RATE
x	1	1	1	Once per minute
x	1	1	0	Minute match
x	1	0	0	Hour and minute match
0	0	0	0	Date, hour, and minute match
1	0	0	0	Day, hour, and minute match

Alarm 2 can be set by writing to registers 13h–15h. See Register Map. The alarm can be programmed by the A2IE bit in Int_en_reg (04h) register to activate the INTB/CLKIN output on an alarm match condition. Bit 7 of each of the time-of-day/ date alarm registers are mask bits. When all the mask bits of each alarm are logic 0, an alarm only occurs when the values in the timekeeping registers match the corresponding values stored in the time-of-day/date

alarm registers. The alarm can also be programmed to repeat every minute, hour, day, or date. The table below shows the possible settings. Configurations not listed in the table result in illogical operation. The DY_DT bit (bit 6 of the alarm day/date registers) control whether the alarm value stored in bits 0-5 that register reflects the day of the week or the date of the month. If DY_DT is written to logic 0, the alarm is the result of a match with date of the month. If DY_DT is written to logic 1, the alarm is the result of a match with day of the week.

BIT	7	6	5	4	3	2	1	0
Field	A2M2	min_10[2:0]			minutes[3:0]			
Reset	0x0	0x0			0x0			
Access Type	Write, Read	Write, Read			Write, Read			

BITFIELD	BITS	DESCRIPTION
A2M2	7	Alarm2 mask bit for minutes
min_10	6:4	Alarm2 minutes in multiples of 10
minutes	3:0	Alarm2 minutes

[Alm2_hrs \(0x14\)](#)

Alarm2 Hours configuration register

BIT	7	6	5	4	3	2	1	0
Field	A2M3	Reserved	hr_10[1:0]		hour[3:0]			
Reset	0x0	0x0	0x0		0x0			
Access Type	Write, Read	Write, Read	Write, Read		Write, Read			

BITFIELD	BITS	DESCRIPTION
A2M3	7	Alarm2 mask bit for hours
Reserved	6	User must enter 0.
hr_10	5:4	Alarm2 hours in multiples of 10
hour	3:0	Alarm2 hours

[Alm2day_date \(0x15\)](#)

Alarm2 Day/Date Configuration register

BIT	7	6	5	4	3	2	1	0
Field	A2M4	DY_DT	date_10[1:0]		day_date[3:0]			
Reset	0x0	0x0	0x0		0x0			
Access Type	Write, Read	Write, Read	Write, Read		Write, Read			

BITFIELD	BITS	DESCRIPTION	DECODE
A2M4	7	Alarm2 mask bit for day/date	
DY_DT	6	This bit selects alarm when day match or date match.	0x0: Alarm when date match 0x1: Alarm when day match
date_10	5:4	Alarm2 date in multiples of 10	
day_date	3:0	Alarm2 day/date	

Timer Count (0x16)

Countdown timer value register

BIT	7	6	5	4	3	2	1	0
Field	Count[7:0]							
Reset	0x00							
Access Type	Read Only							

BITFIELD	BITS	DESCRIPTION
Count	7:0	Countdown timer current count value

Timer Init (0x17)

Countdown timer Initialization register

BIT	7	6	5	4	3	2	1	0
Field	Count[7:0]							
Reset	0x00							
Access Type	Write, Read							

BITFIELD	BITS	DESCRIPTION
Count	7:0	Countdown timer initial value. The timer is loaded with the contents of this register when it reaches to zero in repeat mode

Clock sync_req (0x58)

Clock Synchronization Configuration register

BIT	7	6	5	4	3	2	1	0
Field	–	–	–	–	–	–	SYNC_DELAY[1:0]	
Reset	–	–	–	–	–	–	0x10	
Access Type	–	–	–	–	–	–	Write, Read	

BITFIELD	BITS	DESCRIPTION	DECODE
SYNC_DELAY	1:0	Synchronization delay is the time it takes for the internal countdown chain to reset after the rising edge of Set_RTC. See Minimizing the Clock Synchronization Delay section for further details. To minimize the delay, select the appropriate setting based on the clock configuration.	0x0: Synchronization delay setting for external 1Hz clock (ECLK = 1, CLKSEL = 0) mode. Delay is less than 1 second. 0x1: Synchronization delay setting for external 50Hz/60Hz/32KHz clock (ECLK = 1, CLKSEL = 1/2/3) mode. Delay is less than 100ms. 0x2: Synchronization delay setting for internal oscillator mode (OSCONZ = 0, ECLK = 0). Delay is less than 10ms. 0x3: Reserved

Ordering Information

PART NUMBER	TEMP RANGE	PIN-PACKAGE
MAX31342EWA+T	-40°C to +85°C	8 WLP

+ Denotes a lead(Pb)-free/RoHS-compliant package.

T = Tape and reel.

Revision History

REVISION NUMBER	REVISION DATE	DESCRIPTION	PAGES CHANGED
0	12/18	Initial release	—
1	1/19	Updated <i>Ordering Information</i>	28
2	4/19	Updated <i>General Description, Benefits and Features, Typical Operating Characteristics, Detailed Description, and Register Map</i>	1, 8–10, 12, 13, 16–20, 22–26

For pricing, delivery, and ordering information, please visit Maxim Integrated's online storefront at <https://www.maximintegrated.com/en/storefront/storefront.html>.

Maxim Integrated cannot assume responsibility for use of any circuitry other than circuitry entirely embodied in a Maxim Integrated product. No circuit patent licenses are implied. Maxim Integrated reserves the right to change the circuitry and specifications without notice at any time. The parametric values (min and max limits) shown in the Electrical Characteristics table are guaranteed. Other parametric values quoted in this data sheet are provided for guidance.



Стандарт Электрон Связь

Мы молодая и активно развивающаяся компания в области поставок электронных компонентов. Мы поставляем электронные компоненты отечественного и импортного производства напрямую от производителей и с крупнейших складов мира.

Благодаря сотрудничеству с мировыми поставщиками мы осуществляем комплексные и плановые поставки широчайшего спектра электронных компонентов.

Собственная эффективная логистика и склад в обеспечивает надежную поставку продукции в точно указанные сроки по всей России.

Мы осуществляем техническую поддержку нашим клиентам и предпродажную проверку качества продукции. На все поставляемые продукты мы предоставляем гарантию .

Осуществляем поставки продукции под контролем ВП МО РФ на предприятия военно-промышленного комплекса России , а также работаем в рамках 275 ФЗ с открытием отдельных счетов в уполномоченном банке. Система менеджмента качества компании соответствует требованиям ГОСТ ISO 9001.

Минимальные сроки поставки, гибкие цены, неограниченный ассортимент и индивидуальный подход к клиентам являются основой для выстраивания долгосрочного и эффективного сотрудничества с предприятиями радиоэлектронной промышленности, предприятиями ВПК и научно-исследовательскими институтами России.

С нами вы становитесь еще успешнее!

Наши контакты:

Телефон: +7 812 627 14 35

Электронная почта: sales@st-electron.ru

Адрес: 198099, Санкт-Петербург,
Промышленная ул, дом № 19, литера Н,
помещение 100-Н Офис 331