

USB Type-C™ to DisplayPort™ adapter

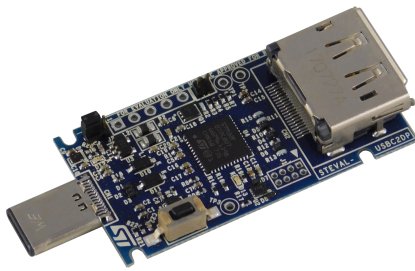

Features

- Full reference design for USB Type-C to DisplayPort adapter with USB Type-C connector and DisplayPort connector.
- Single chip solution based on the STM32F072 series 32-bit microcontrollers with integrated USB 2.0 peripheral.
- Based on certified X-CUBE-USB-PD middleware stack, compliant with the following standards and specifications:
 - USB Type-C Cable and Connector 1.3
 - USB Power Delivery 2.0 and 3.0
 - VESA DisplayPort Alternate Mode on USB Type-C Standard 1.0a
 - USB Device Class Definition for Billboard Devices 1.21
- EMI filtering and ESD protection circuits.
- Compact PCB design: 5.5 x 2.3 cm
- RoHS compliant

Description

The compact USB Type-C to DisplayPort adapter reference design, with USB Type-C connector and DisplayPort connector, exploits Alternate Mode of the USB Type-C and Power Delivery specifications to offer a comprehensive VESA® DisplayPort Standard interface.

With this adapter, you can connect a monitor with a DisplayPort interface to any laptop, tablet or smartphone with a reversible USB Type-C connector that is compliant with the Power Delivery specification.

The DisplayPort Alternate Mode allows video data to be delivered through the SuperSpeed USB lines on the Type-C connector, while Auxiliary lanes (AUX) and hot plug detection (HPD) signals are sent through other Type-C lines.

The high-performance ARM® Cortex®-M0 32-bit STM32F072 microcontroller engages in DisplayPort Alt Mode negotiation through vendor-defined messages (VDM) according to the USB Power Delivery Specification. The messages are transmitted along configuration channel (CC), through a simple discrete analog front end (AFE) interface between the STM32 MCU and the USB Type-C connector.

The STM32 microcontroller running the ST USB Middleware stack and the embedded USB 2.0 controller provide the Billboard Device Class support as required by the USB Power Delivery standard, as well as the Device Firmware Upgrade capability.

Summary table	
STEVAL-USBC2DP USB Type-C™ to DisplayPort™ adapter	STEVAL-USBC2DP
X-CUBE-USB-PD software expansion for STM32Cube	X-CUBE-USB-PD
STM32F072 series 32-bit ARM Cortex MCU with crystal-less USB 2.0 FS interface	STM32F072
LDK220 200 mA low quiescent current and low noise LDO	LDK220
STG3684A low voltage 0.5 Ω max dual SPDT switch	STG3684A

1 USB Type-C to DisplayPort reference design architecture

The STEVAL-USBC2DP reference design for the USB Type-C to VESA DisplayPort adapter is a complete solution based on the following logical blocks:

1. A USB Type-C reversible connector
2. A DisplayPort connector
3. An STM32F072 MCU running the X-CUBE-USB-PD software package with Middleware stack
4. A USB Type-C discrete analog front end
5. The on-board power management stage controlled by the LDK220 low dropout voltage regulator to supply the dongle through the Type-C connector VBUS or VCONN pins
6. The STG3684A low voltage 0.5 Ω max. dual SPDT switch between the DisplayPort auxiliary (AUX) and the side-band unit (SBU) lines

Figure 1. STEVAL-USBC2DP system architecture block diagram

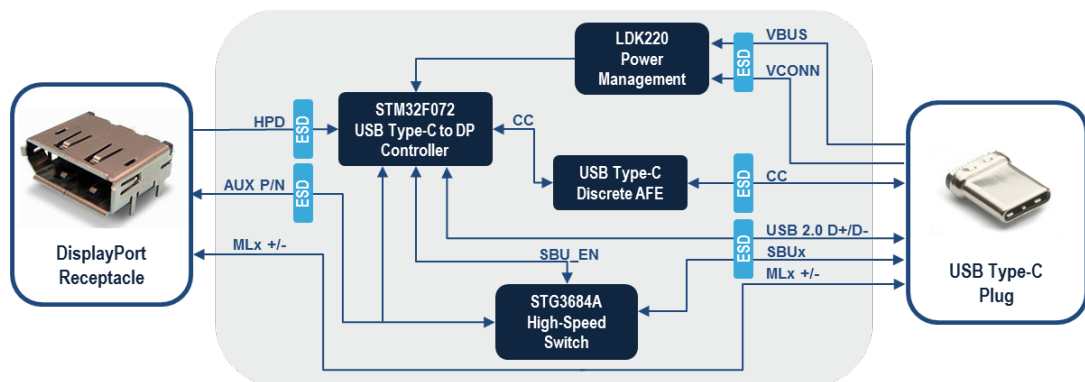

The adapter reference design also features:

- Dual supply options through USB Type-C connector:
 - VBUS
 - VCONN
- VBUS voltage sensing for power monitoring
- USB 2.0 interface available on Type-C™ port for Billboard Device Class and Device Firmware Upgrade
- A power status LED and USB Power Delivery Status LED
- A RESET button
- On-board SWD connector that can be connected with the ST-LINK/V2-1 debugger/programmer embedded on STM32 Nucleo boards

2 Schematic diagrams

Figure 2. MCU section

Figure 3. USB Type-C Plug

Figure 4. DisplayPort Receptacle

Figure 5. Power Management Stage

Figure 6. Hi-Speed Data Switch

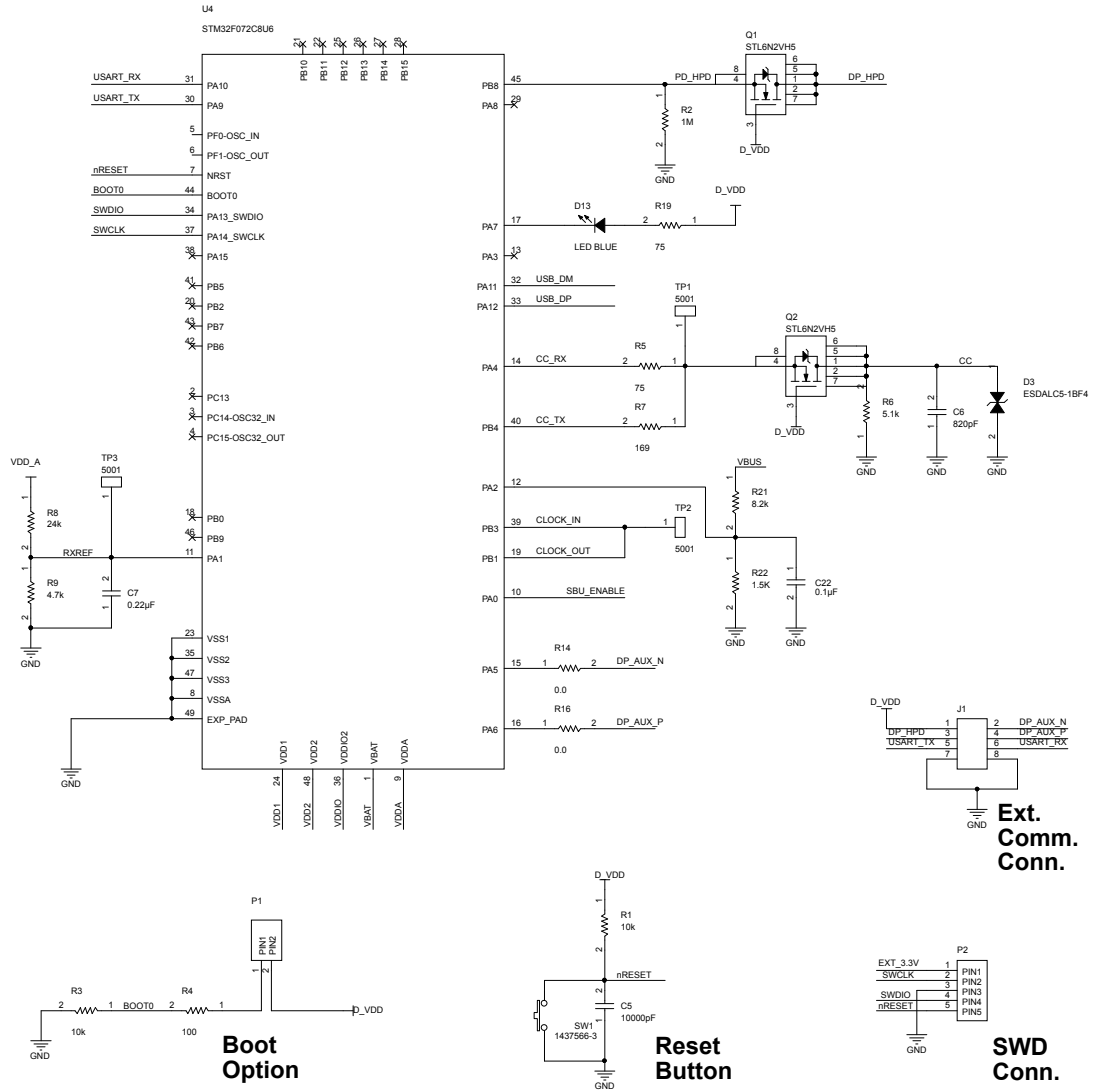
3 References

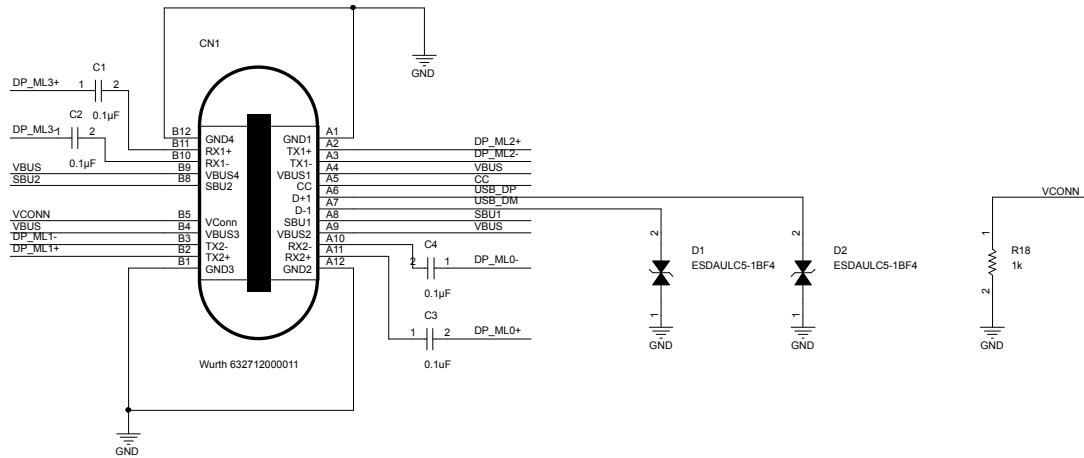
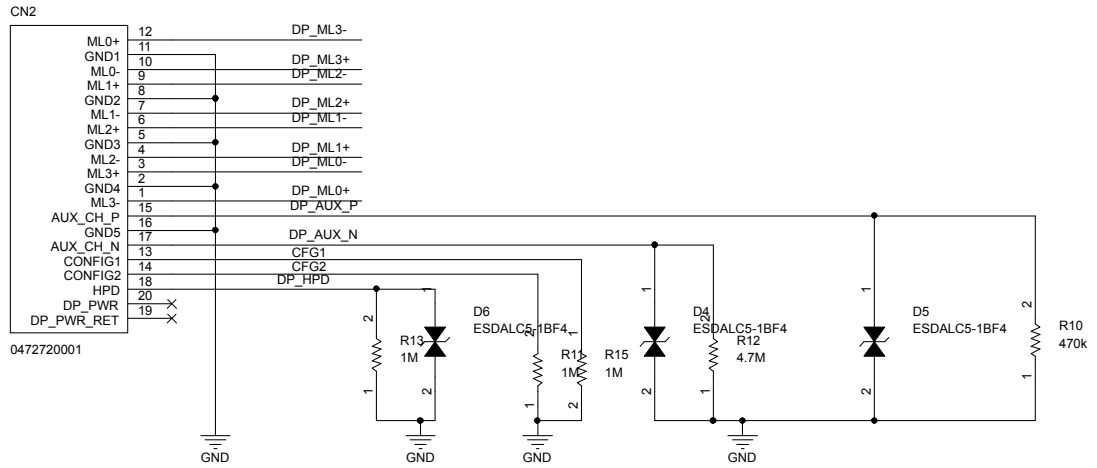
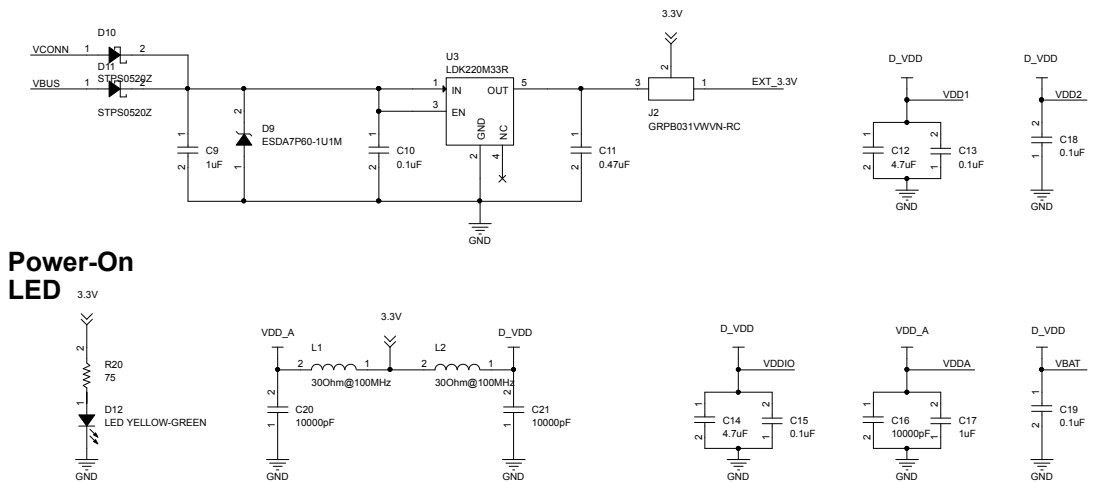
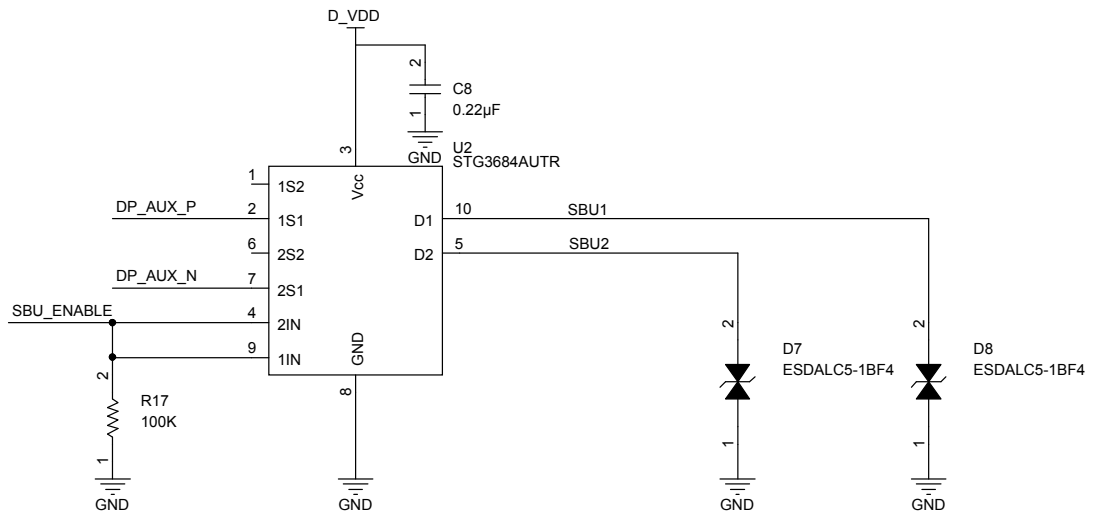
1. USB Type-C™ Cable and Connector Specification, Release 1.3, July 12, 2017.
2. USB Power Delivery Specification Revision 3.0, Version 1.1, January 12, 2017.
3. VESA DisplayPort Alternate Mode on USB Type-C Standard, Version 1.0a, August 05, 2015.
4. USB Device Class Definition for Billboard Devices, Revision 1.21, September 8, 2016.

Revision history

Table 1. Document revision history

Date	Version	Changes
01-Feb-2018	1	Initial release.
19-Feb-2018	2	Minor text edits
27-Feb-2018	3	Minor text edits

IMPORTANT NOTICE – PLEASE READ CAREFULLY

STMicroelectronics NV and its subsidiaries (“ST”) reserve the right to make changes, corrections, enhancements, modifications, and improvements to ST products and/or to this document at any time without notice. Purchasers should obtain the latest relevant information on ST products before placing orders. ST products are sold pursuant to ST’s terms and conditions of sale in place at the time of order acknowledgement.

Purchasers are solely responsible for the choice, selection, and use of ST products and ST assumes no liability for application assistance or the design of Purchasers’ products.

No license, express or implied, to any intellectual property right is granted by ST herein.

Resale of ST products with provisions different from the information set forth herein shall void any warranty granted by ST for such product.

ST and the ST logo are trademarks of ST. All other product or service names are the property of their respective owners.

Information in this document supersedes and replaces information previously supplied in any prior versions of this document.

© 2018 STMicroelectronics – All rights reserved



Стандарт Электрон Связь

Мы молодая и активно развивающаяся компания в области поставок электронных компонентов. Мы поставляем электронные компоненты отечественного и импортного производства напрямую от производителей и с крупнейших складов мира.

Благодаря сотрудничеству с мировыми поставщиками мы осуществляем комплексные и плановые поставки широчайшего спектра электронных компонентов.

Собственная эффективная логистика и склад в обеспечивает надежную поставку продукции в точно указанные сроки по всей России.

Мы осуществляем техническую поддержку нашим клиентам и предпродажную проверку качества продукции. На все поставляемые продукты мы предоставляем гарантию .

Осуществляем поставки продукции под контролем ВП МО РФ на предприятия военно-промышленного комплекса России , а также работаем в рамках 275 ФЗ с открытием отдельных счетов в уполномоченном банке. Система менеджмента качества компании соответствует требованиям ГОСТ ISO 9001.

Минимальные сроки поставки, гибкие цены, неограниченный ассортимент и индивидуальный подход к клиентам являются основой для выстраивания долгосрочного и эффективного сотрудничества с предприятиями радиоэлектронной промышленности, предприятиями ВПК и научно-исследовательскими институтами России.

С нами вы становитесь еще успешнее!

Наши контакты:

Телефон: +7 812 627 14 35

Электронная почта: sales@st-electron.ru

Адрес: 198099, Санкт-Петербург,
Промышленная ул, дом № 19, литера Н,
помещение 100-Н Офис 331