

Emergency stop and safety guard monitoring 2 channels KNE3-YS Part number 85102434



- "Emergency stop" & "Safety gates monitoring" functions
- Single and 2-channel operation
- Security with redundancy and feedback circuit
- 3 "NO" security contacts
- 1 "NC" monitoring contact
- Security category 4 (according to EN 954-1)
- Performance Level (PL) e, safety category 4 to EN ISO 13849-1
- SIL Claimed Level (SIL CL) 3 to IEC/EN 62061
- Terminals : fixed screw terminals or plugin cage clamp terminals

Part numbers

| Type | Terminals | Voltages | Supply frequency range (Hz) | Outputs |
|------------------|-----------|-------------|-----------------------------|-------------|
| 85102434 KNE3-YS | Screws | 110-115 VAC | 50/60 | 3 NO + 1 NC |

Specifications

Operating characteristics

| | |
|--------------------------------|---|
| Functions | Emergency stop Safety gates monitoring |
| Operation | 1 or 2 channels |
| Control input | Manual restart with On-button (Y1 - Y2 terminals) Automatic restart (switch S2 & Y1 - Y2 linked) |
| Failure detection | Monitored start on On-button With or without cross fault monitoring in the emergency-stop loop (switch S1) |
| Display of output state by LED | Power supply : PWR Output : OUT1 (relay K1) Output : OUT2 (relay K2) |

Supply

| | |
|-----------------------------|--|
| Supply voltage | 85 102 436 / 85 103 436 : 24 V AC/DC 85 102 434 : 110-115 VAC 85 102 435 : 230 VAC |
| Supply frequency range (Hz) | 50 / 60 |
| Operating range | AC/DC : $\pm 10\%$ Un AC : -15 % +10 % Un |
| Consumption | 1,5 W (24 VDC) 3,7 VA (230 VAC) |
| Initialization time | 250 ms |

Precision

| | |
|---|--|
| Maximum reset time | 30 ms (manual start) 350 ms (automatic start) |
| Maximum response time on emergency stop | 150 ms (AC/DC) 50 ms (AC) |

Output specification

| | |
|---|---|
| Type | Forcibly guided relays (positively driven) |
| Number of safety circuits | 3 NO |
| Number of data circuits | 1 NC |
| Nominal output voltage | 250 V AC max. |
| Max. thermal current I for each contact | 8 A |
| Maximum power rating | According to AC15 (NO contacts) : 3 A / 230 V AC According to AC15 (NC contacts) : 2 A / 230 VAC According to DC13 (NO contacts) : 4 A / 24 VDC ; 0,5 A / 110 VDC According to DC13 (NC contacts) : 4 A / 24 VDC |
| Electrical endurance | At 5 A, 230 VAC, $\cos \varphi = 1$: $1,5 \times 10^5$ switching cycles At 8 A, 24 VDC, according to DC 13 (NO contacts) : 25×10^3 switching cycles (ON : 0,4 s ; OFF : 9,6 s) |
| Mechanical life | 20×10^6 switching cycles |
| Maximum rate | 1200 switching cycles / h |
| Protection against short circuits | Max. fuse rating : 10 A gL Line circuit breaker : B 6 A |

Climatic environment

| | |
|--|---------------|
| Operating temperature (°C) | -15 → +55 |
| Storage temperature (°C) | -25 → +85 |
| Altitude | < 2000 m |
| Climate resistance according to IEC/EN 60068-1 | 15 / 055 / 04 |

Mechanical environment

| | |
|--|--|
| Vibration resistance according to IEC/EN 60068-2-6 | Amplitude : 0,35 mm Frequency : 10 →55 Hz |
|--|--|

Electromagnetic environment

| | |
|--|--|
| Immunity to electrostatic discharges acc. IEC/EN 61000-4-2 | 8 kV (air) |
| Immunity to radiated, radio-frequency, electromagnetic field acc. IEC/EN 61000-4-3 | 10 V / m |
| Immunity to rapid transient bursts acc. to IEC/EN 61000-4-4 | 2 kV |
| Immunity to shock waves according to IEC/EN 61000-4-5 | Between wires for power supply : 1 kV (AC), 0,5 kV (24 V AC/DC) Between wires and ground : 2 kV |
| Immunity to radio frequency in common mode acc. to IEC/EN 61000-4-6 | 10 V |
| Interference suppression according to IEC/EN 55011 | Limit value class B |

Housing

| | |
|---|--|
| Material : self-extinguishing (UL94VO) | Thermoplastic with V0 extinction behaviour |
| Protection (IEC/EN 60529) - Casing | IP40 |
| Protection (IEC/EN 60529) - Term. block | IP20 |
| Mounting | DIN-rail |
| Weight (g) | 210 (24 VAC/DC) 275 (230 VAC) |

Safety standards

| | |
|--|--|
| Approvals | CE, TÜV, UL / CSA |
| Environmental directive 2002/95/CE | RoHS |
| Environmental regulation 1907/2006 | Reach |
| Security data according to EN ISO 13849-1 | Performance Level (PL) : e Category : 4 |
| SIL Claimed Level (SIL CL) to IEC/EN 62061 | 3 |
| Safety Integrity Level (SIL) according to CEI/EN 61508 | 3 |
| Safety category to EN 954-1 | 4 |

Principles

| | | |
|------------------------|-------|-----------------|
| EN ISO 13849-1: | | |
| Category: | 4 | |
| PL: | e | |
| MTTF _d : | > 100 | a (year) |
| DC _{avg} : | 99,0 | % |
| d _{op} : | 365 | d/a (days/year) |
| h _{op} : | 24 | h/d (hours/day) |
| t _{cycle} : | 3600 | s/cycle |
| | ≅ 1 | /h (hour) |

| | | |
|---------------------------------------|----------|-----------------|
| IEC/EN 62061 IEC/EN 61508: | | |
| SIL CL: | 3 | IEC/EN 62061 |
| SIL | 3 | IEC/EN 61508 |
| HFT ^{*)} : | 1 | |
| DC _{avg} : | 99,0 | % |
| SFF | 99,7 | % |
| PFH _D : | 2,66E-10 | h ⁻¹ |
| *) HFT = Hardware failure tolerance | | |

Dimensions (mm)



Dimensions (mm)

KNE3-YS - Screw terminals

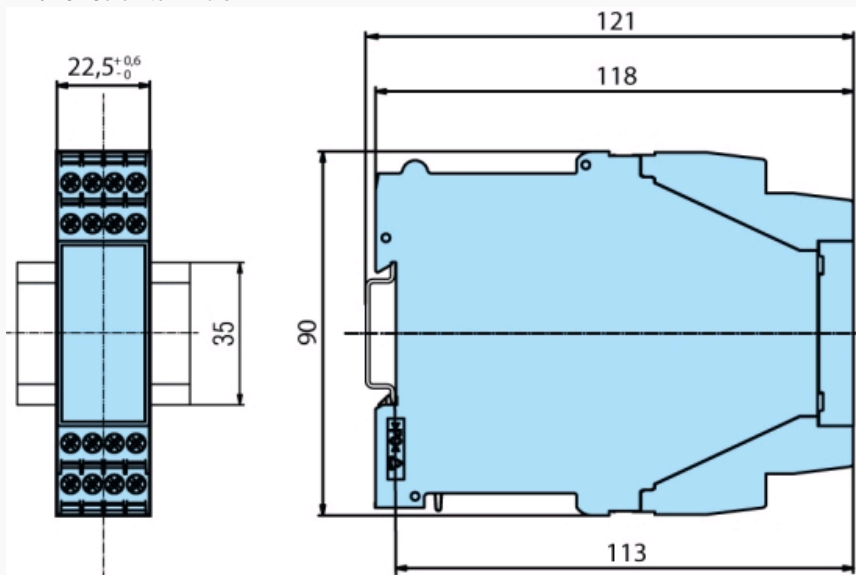

Curves

Function diagram

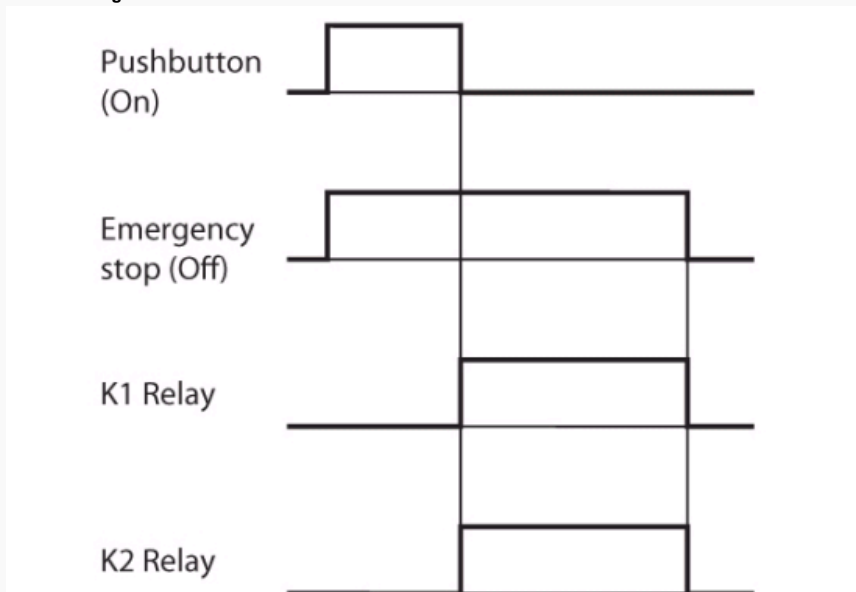

Connections

Front face drawing KNE3-YS

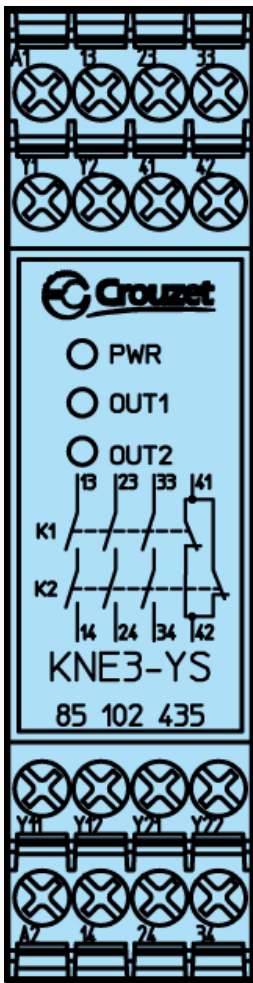

Connections

Contacts

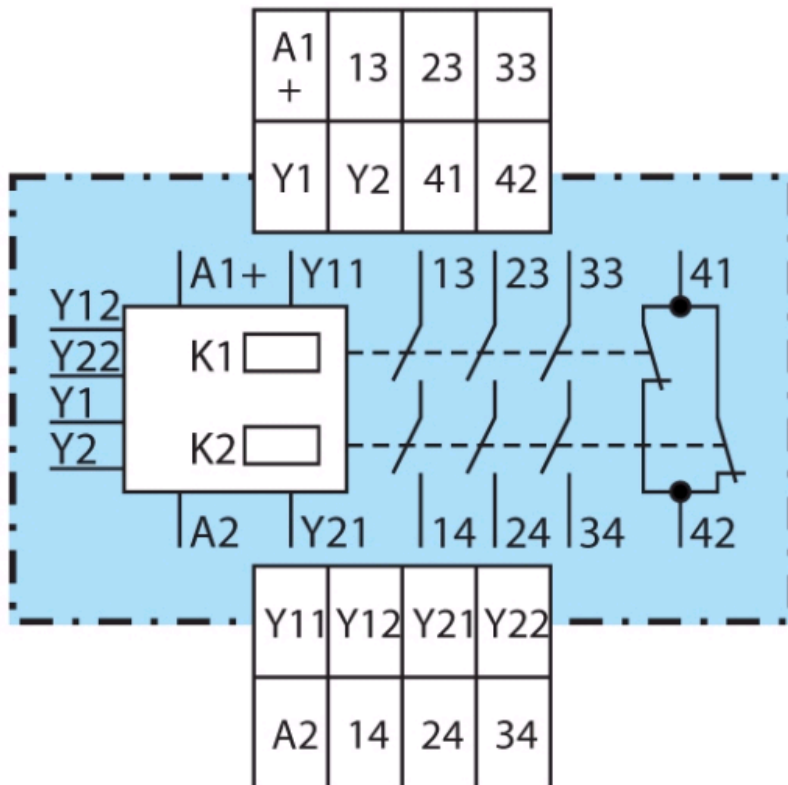

A1 (+) : + / L A2 : - / N Y1, Y2 : Validation Input Y11, Y21, Y12, Y22 : Control Inputs 13, 14, 23, 24, 33, 34 : Safety circuit outputs (forcibly guided NO contacts) 41, 42 : Monitoring output (forcibly

Applications

Single channel emergency stop circuit

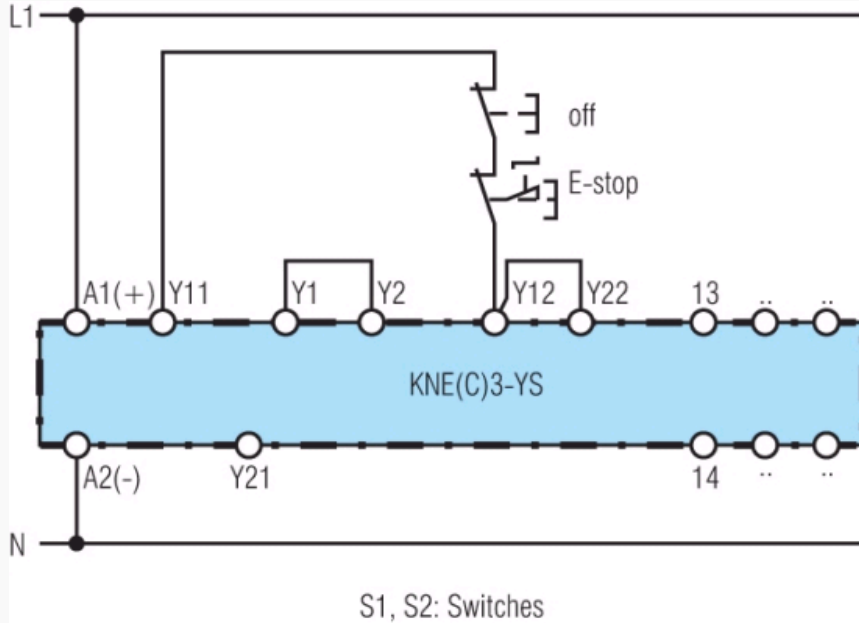

This circuit does not have any redundancy in the emergency-stop control circuit. S1 : no cross fault detection S2 : automatic start

Applications

2-channel emergency stop circuit without cross fault monitoring

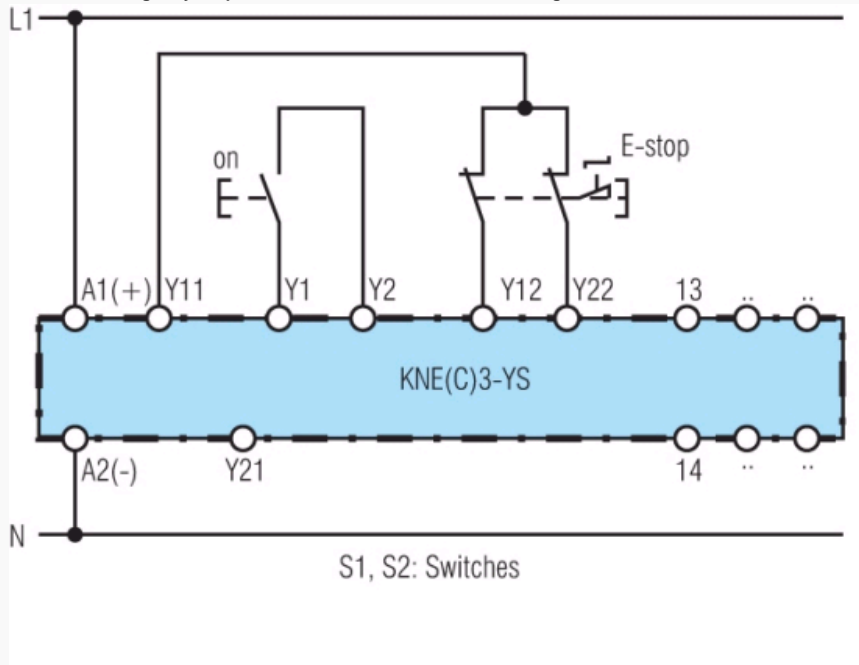

S1 : no cross fault detection S2 : manual start

Applications

Contact reinforcement by external contactors controlled by one contact path

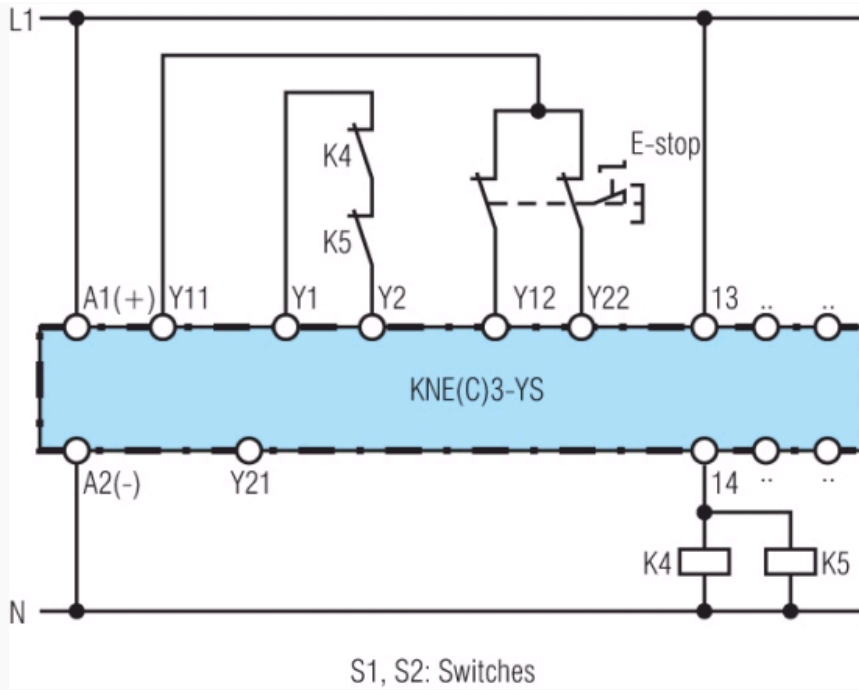

S1 : no cross fault detection S2 : automatic start

Applications
2-channel safety gate monitoring

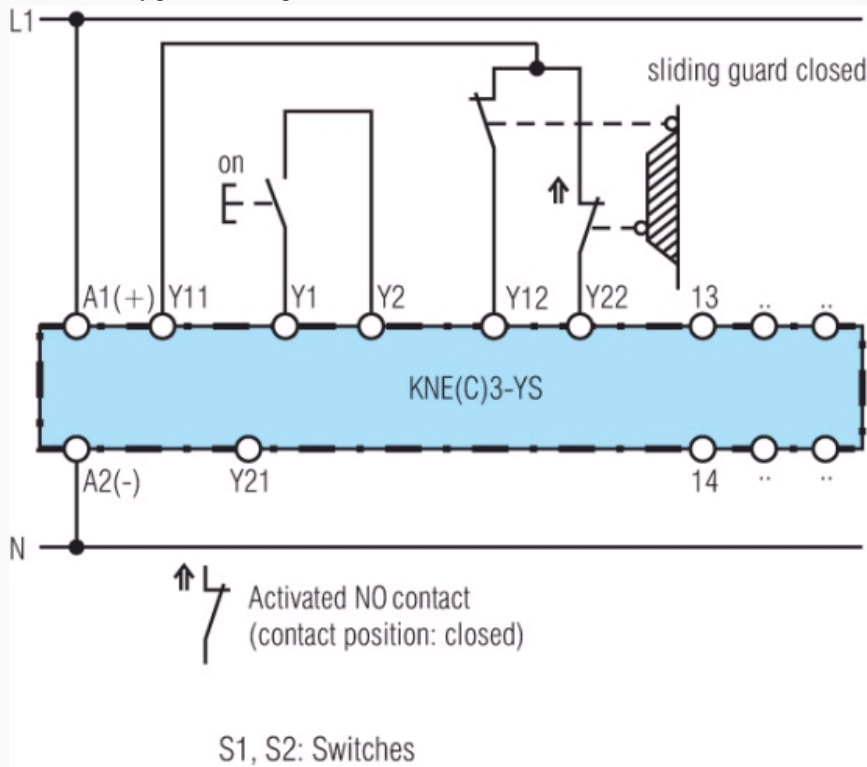

S1 : no cross fault detection S2 : manual start

Applications
Contact reinforcement by external contactors, 2-channel controlled

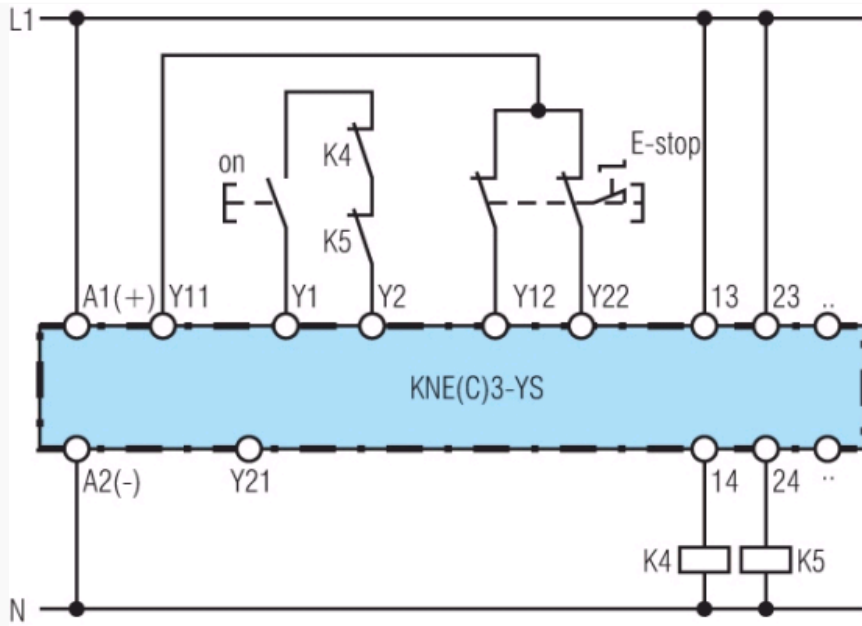

S1, S2: Switches

For currents > 8 A, the output contacts can be reinforced by external contactors. Functioning of the external contactors is monitored by looping the NC contacts into the start circuit (Y1-Y2)

Applications

2-channel emergency stop circuit with cross fault monitoring

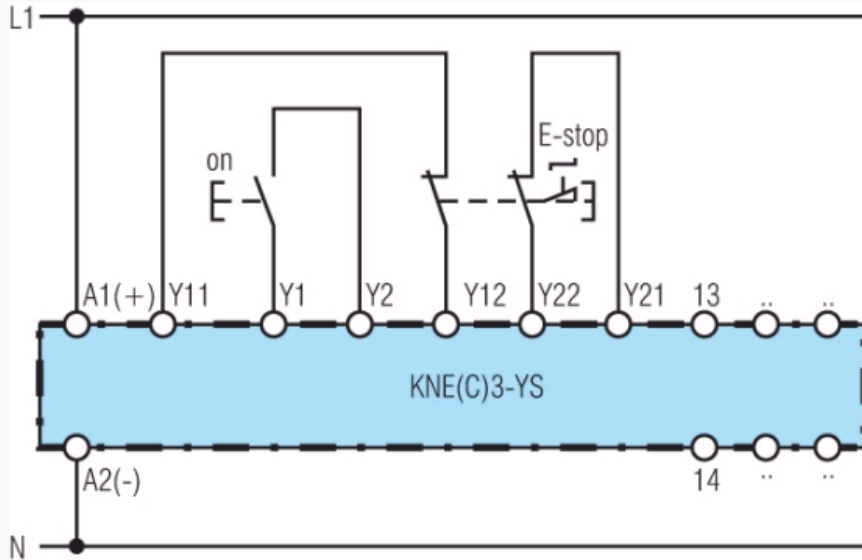

S1, S2: Switches

S1 : cross fault detection S2 : manual start



Стандарт Электрон Связь

Мы молодая и активно развивающаяся компания в области поставок электронных компонентов. Мы поставляем электронные компоненты отечественного и импортного производства напрямую от производителей и с крупнейших складов мира.

Благодаря сотрудничеству с мировыми поставщиками мы осуществляем комплексные и плановые поставки широчайшего спектра электронных компонентов.

Собственная эффективная логистика и склад в обеспечивает надежную поставку продукции в точно указанные сроки по всей России.

Мы осуществляем техническую поддержку нашим клиентам и предпродажную проверку качества продукции. На все поставляемые продукты мы предоставляем гарантию .

Осуществляем поставки продукции под контролем ВП МО РФ на предприятия военно-промышленного комплекса России , а также работаем в рамках 275 ФЗ с открытием отдельных счетов в уполномоченном банке. Система менеджмента качества компании соответствует требованиям ГОСТ ISO 9001.

Минимальные сроки поставки, гибкие цены, неограниченный ассортимент и индивидуальный подход к клиентам являются основой для выстраивания долгосрочного и эффективного сотрудничества с предприятиями радиоэлектронной промышленности, предприятиями ВПК и научно-исследовательскими институтами России.

С нами вы становитесь еще успешнее!

Наши контакты:

Телефон: +7 812 627 14 35

Электронная почта: sales@st-electron.ru

Адрес: 198099, Санкт-Петербург,
Промышленная ул, дом № 19, литера Н,
помещение 100-Н Офис 331