

# 8V9705x Evaluation Board User Guide IDT Applications

October 2016

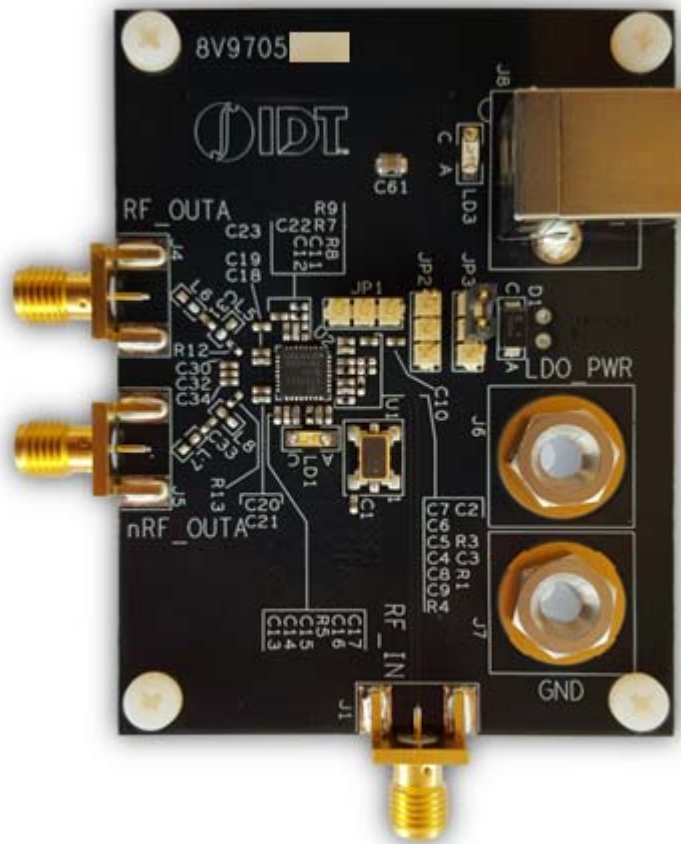

**Contents**

Introduction .....3

Contents .....3

Requirements .....3

Quick Start .....3

Default Power-Up Condition .....3

Board Overview .....4

Schematics .....7

Powering from an External Supply .....10

External Signal Reference Configuration .....11

DC Controls .....11

**Figures**

Figure 1. Evaluation Board Top View.....4

Figure 2. Evaluation Board Bottom View.....6

Figure 3. Input Schematic.....7

Figure 4. Output Termination Schematic.....7

Figure 5. Loop Filter Schematic .....8

Figure 6 . Power Source Selection Schematic .....8

Figure 7. LDO Power Schematic .....9

Figure 8. I2C-to-SPI Translation Schematic .....9

Figure 9. 8V9705x DUT Schematic.....10

Figure 10. External Power Configuration .....10

Figure 11. External Signal Reference Configuration.....11

## Introduction

The 8V9705x evaluation board is designed to help the customer evaluate the 8V97051, 8V97051L, 8V97053 and 8V97053L IDT Wideband RF synthesizers. When the board is connected to a PC running IDT Timing Commander Software through USB, the device can be configured and programmed to generate frequencies with best-in-class performances.

## Contents

The 8V9705x evaluation board kit ships with the following:

- (1) 8V9705x Evaluation Board
- (1) USB Cable

## Requirements

PC Requirements:

- IDT Timing Commander Software Installed.
- USB 2.0 or USB 3.0 interface.
- Windows XP SP3 or later.
- Processor: Minimum 1GHz.
- Memory: Minimum 512MB, recommended 1GB.
- Available Disk Space: Min 600MB (1.5GB 64bit), recommended 1GB (2GB 64bit)
- Network access during installation if the .NET framework is not currently installed on the system.

## Quick Start

- (1) Connect a cable from a PC to the Evaluation Board USB port.
- (2) Verify that the board is configured to power from the USB (see JP3 jumper position in Fig.1)
- (3) JP2 and JP3 can be left floating.
- (4) Connect 50ohm cables from the RF\_OUTA output to the measurement equipment.
- (5) Configure the device using Timing Commander.

## Default Power-Up Condition

The board ships with a 25MHz TXCO and is configured to power from the USB. No external reference is required and no external power source, aside from the USB connection, is required. Outputs are disabled by default. The device must be configured using Timing Commander in order to activate the output.

Note: this device also has an RF\_OUTb differential output that is not routed out on the evaluation board.

## Board Overview

Use the following diagram to identify: power supply jacks, USB connector, input and output SMA connectors, TCXO, etc.

Figure 1. Evaluation Board Top View

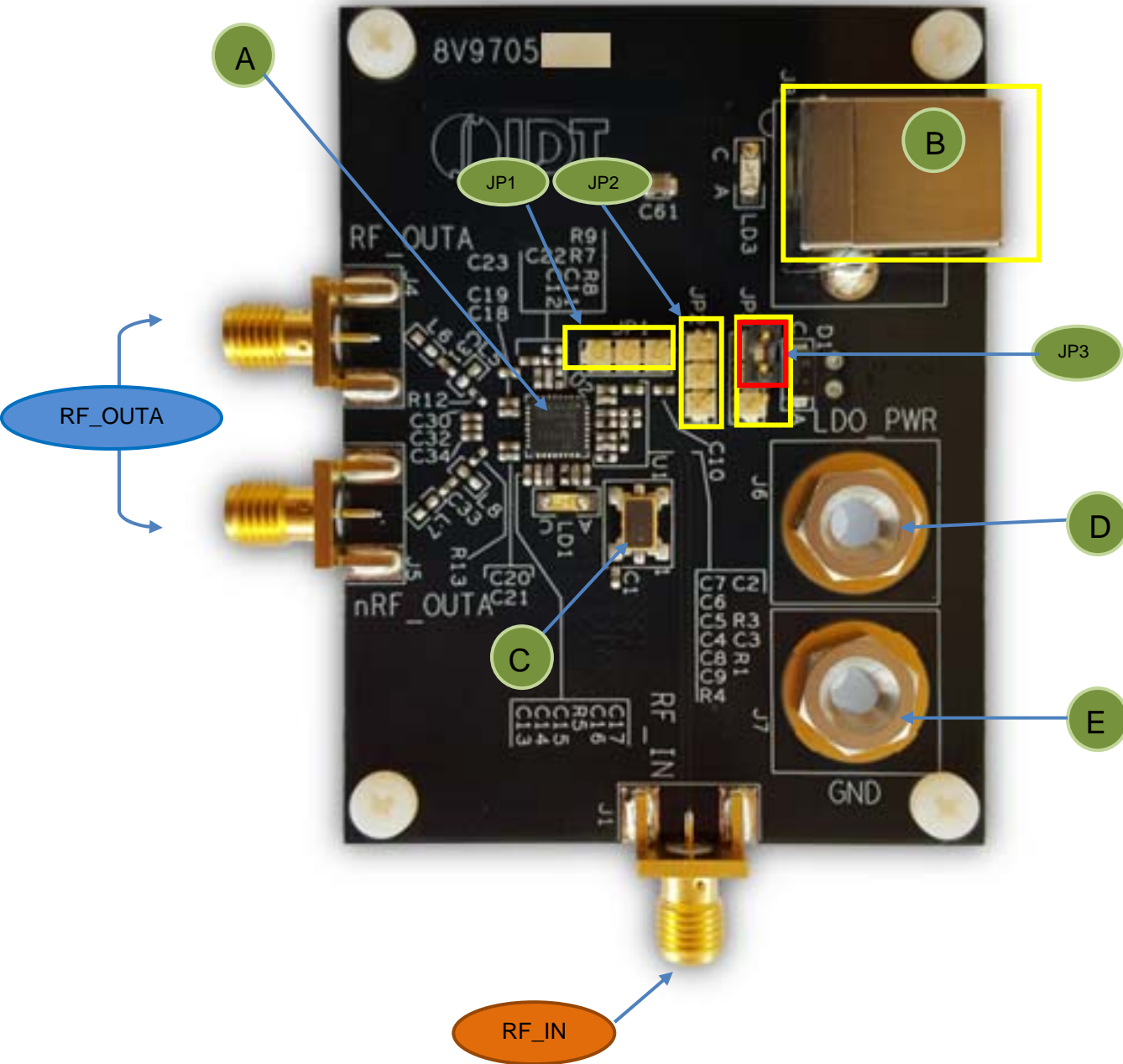

## Legend

### Inputs

RF\_IN          Reference input (the board requires re-work to enable this option)

### Outputs

RF\_OUTA      Open-drain, ac-coupled output.

### Other

- A      IDT8V9705x- the device to be evaluated
- B      USB connector (also powers the board)
- C      25 MHz TXCO (default reference source)
- D      External LDO\_POWER (alternate power source)
- E      GND
- JP1    MUTE control (can be left floating)
- JP2    CE control (can be left floating)
- JP3    Power Source selector (USB vs LDO\_PWR power source)

Figure 2. Evaluation Board Bottom View

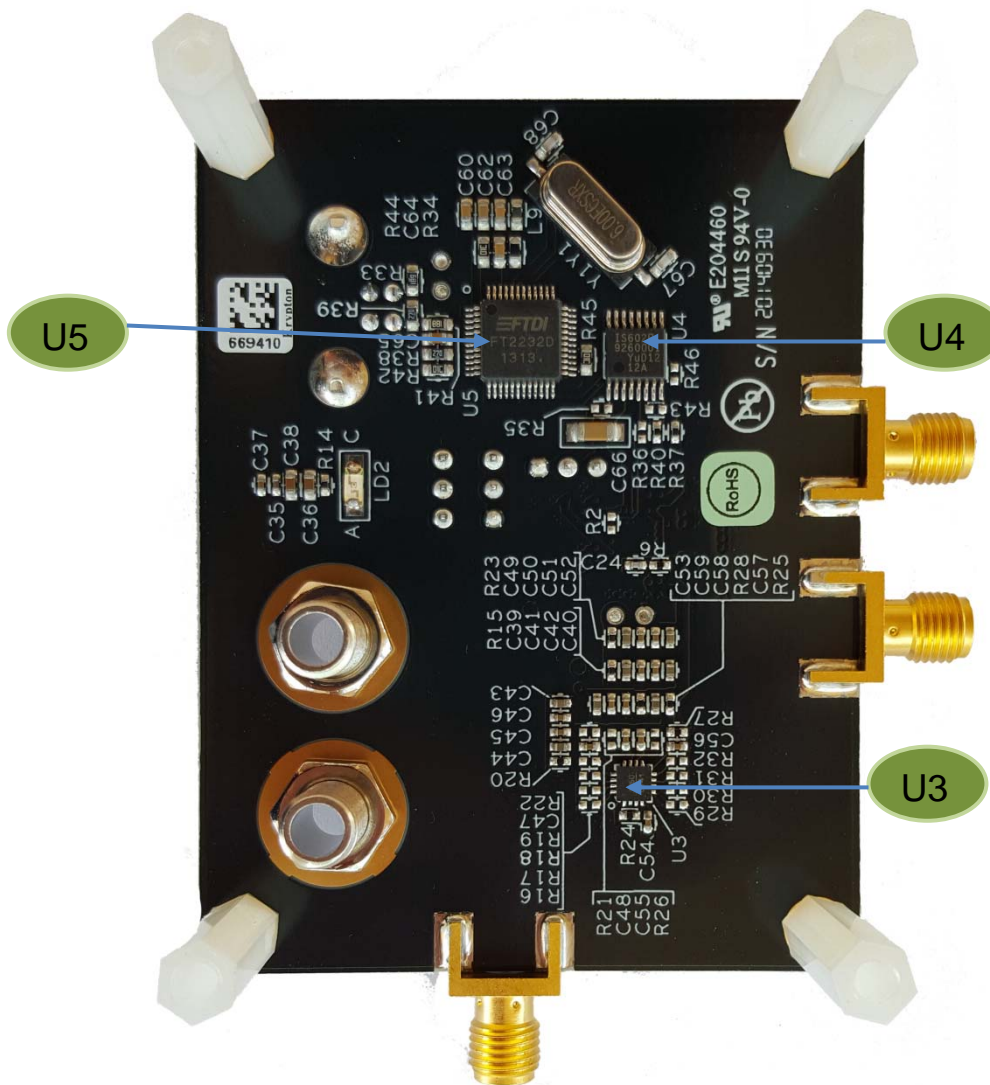

**Legend**

- U5 FTDI USB-to-I2C chip
- U4 USB-to-SPI translator
- U3 LDO

## Schematics

The following figures are schematics that are applicable to specific sections of this User Guide. The complete schematics are available in a separate document.

Figure 3. Input Schematic

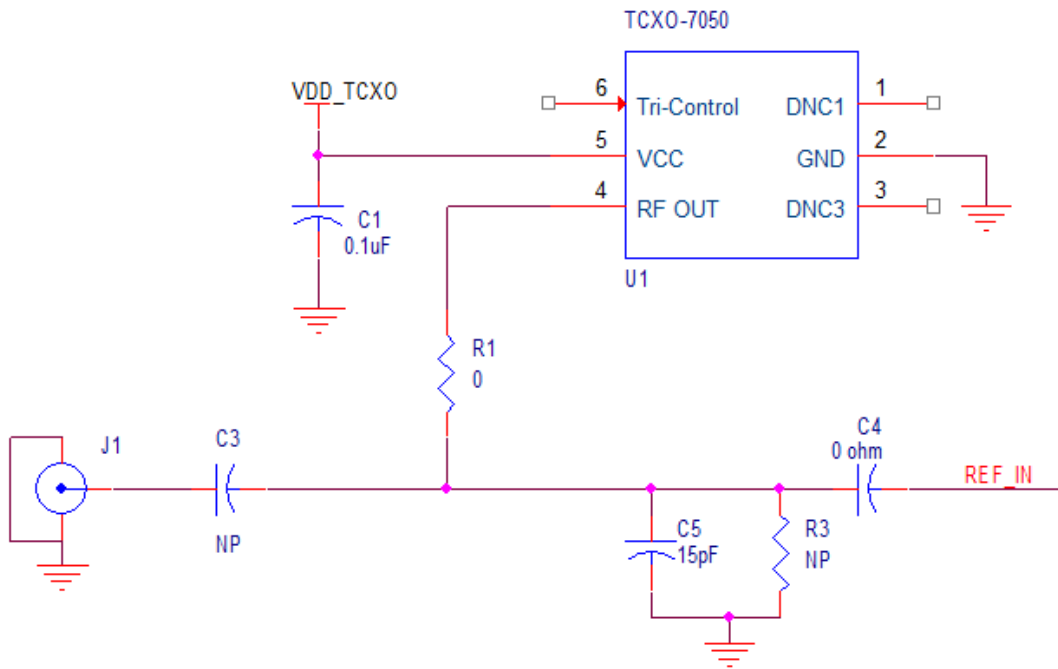

Figure 4. Output Termination Schematic

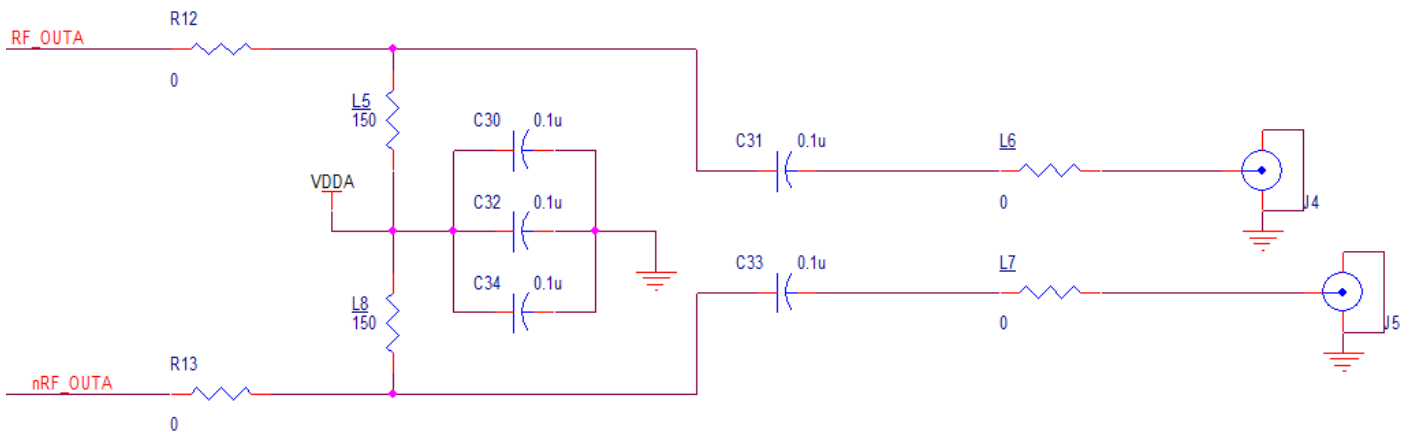

Figure 5. Loop Filter Schematic

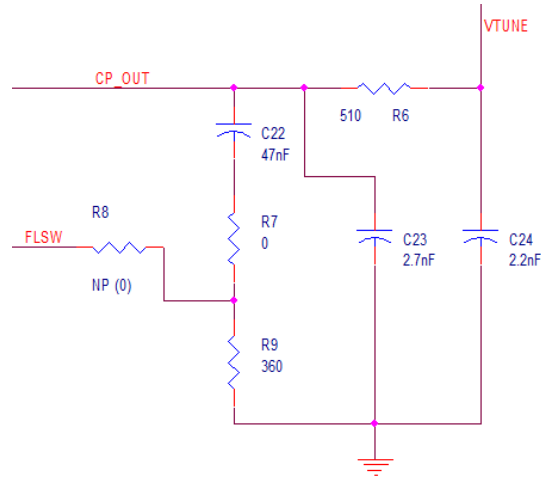

Figure 6 . Power Source Selection Schematic

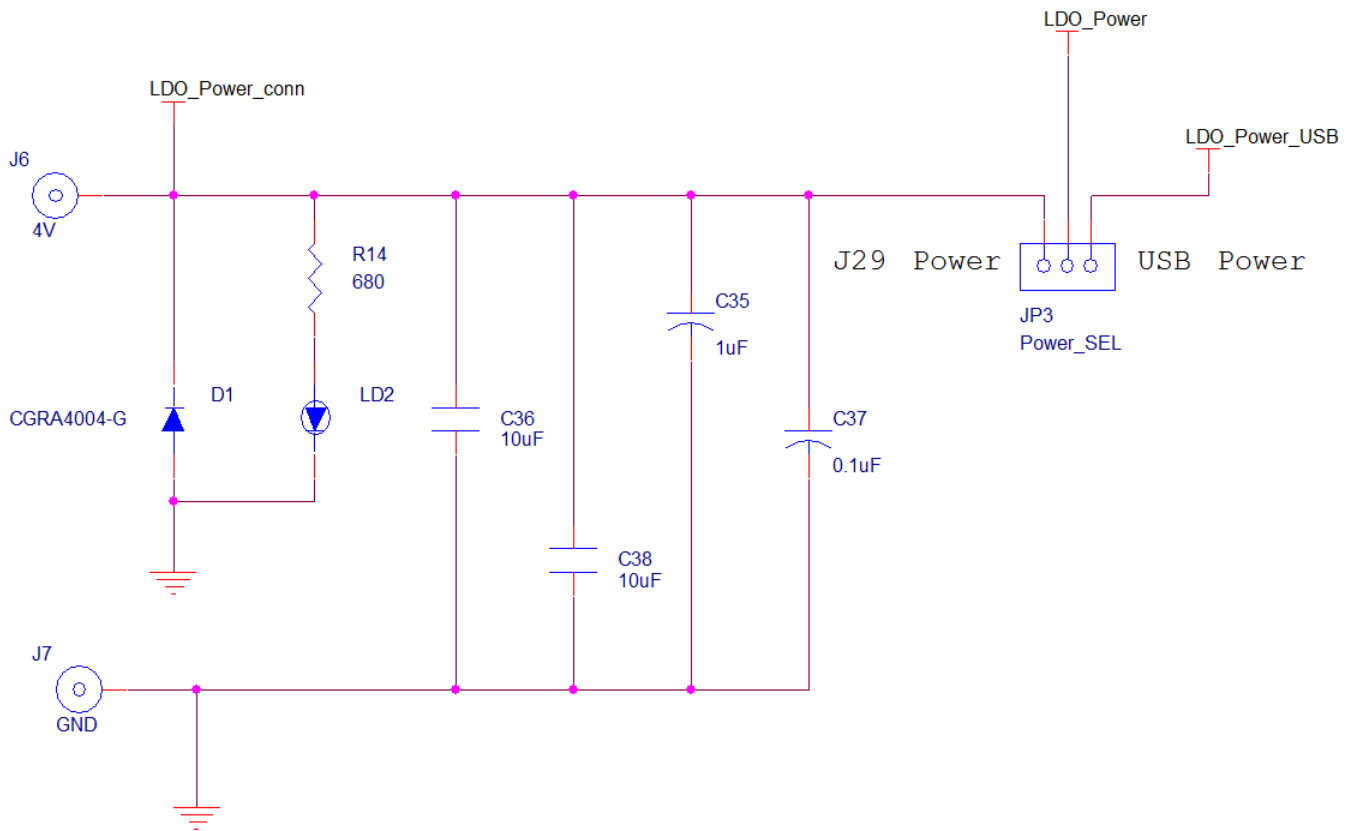
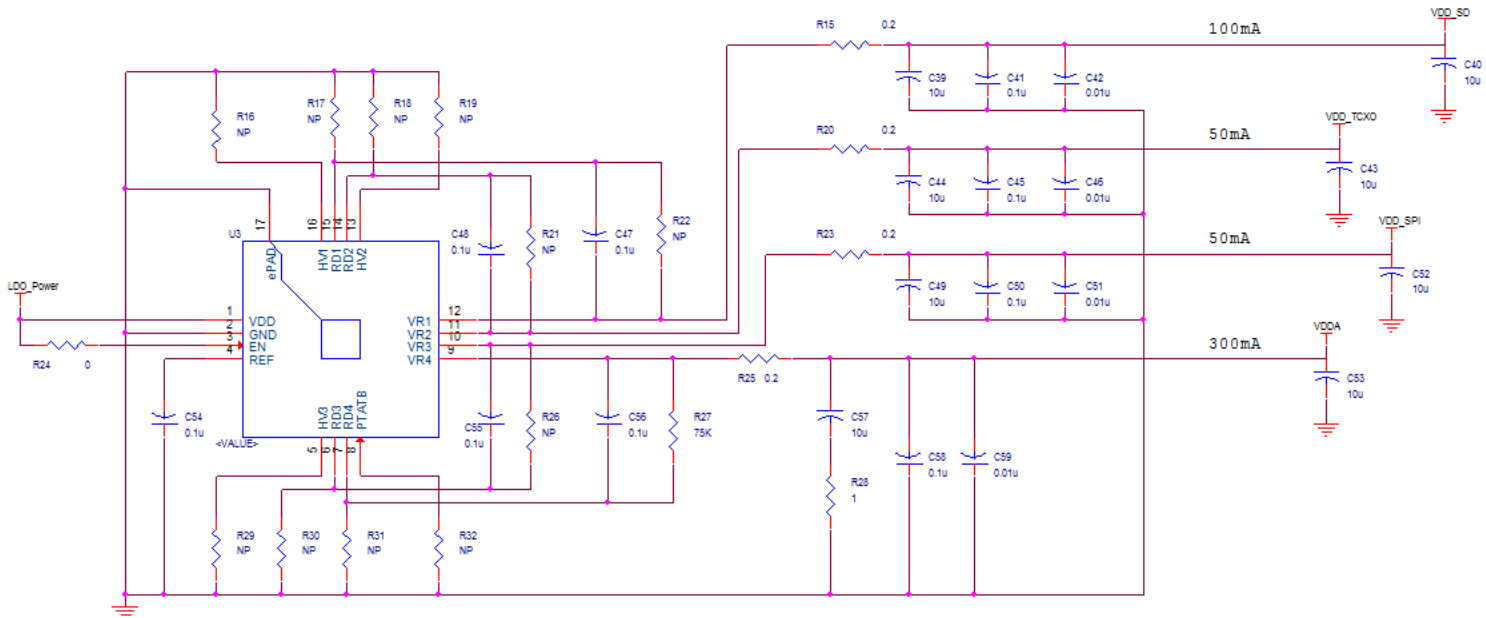



Figure 7. LDO Power Schematic



VDDA = V\_CP, VDDA, V\_VCO, VDDD

VDD\_SPI = Translator, I2C PU, SPI PU

Figure 8. I2C-to-SPI Translation Schematic

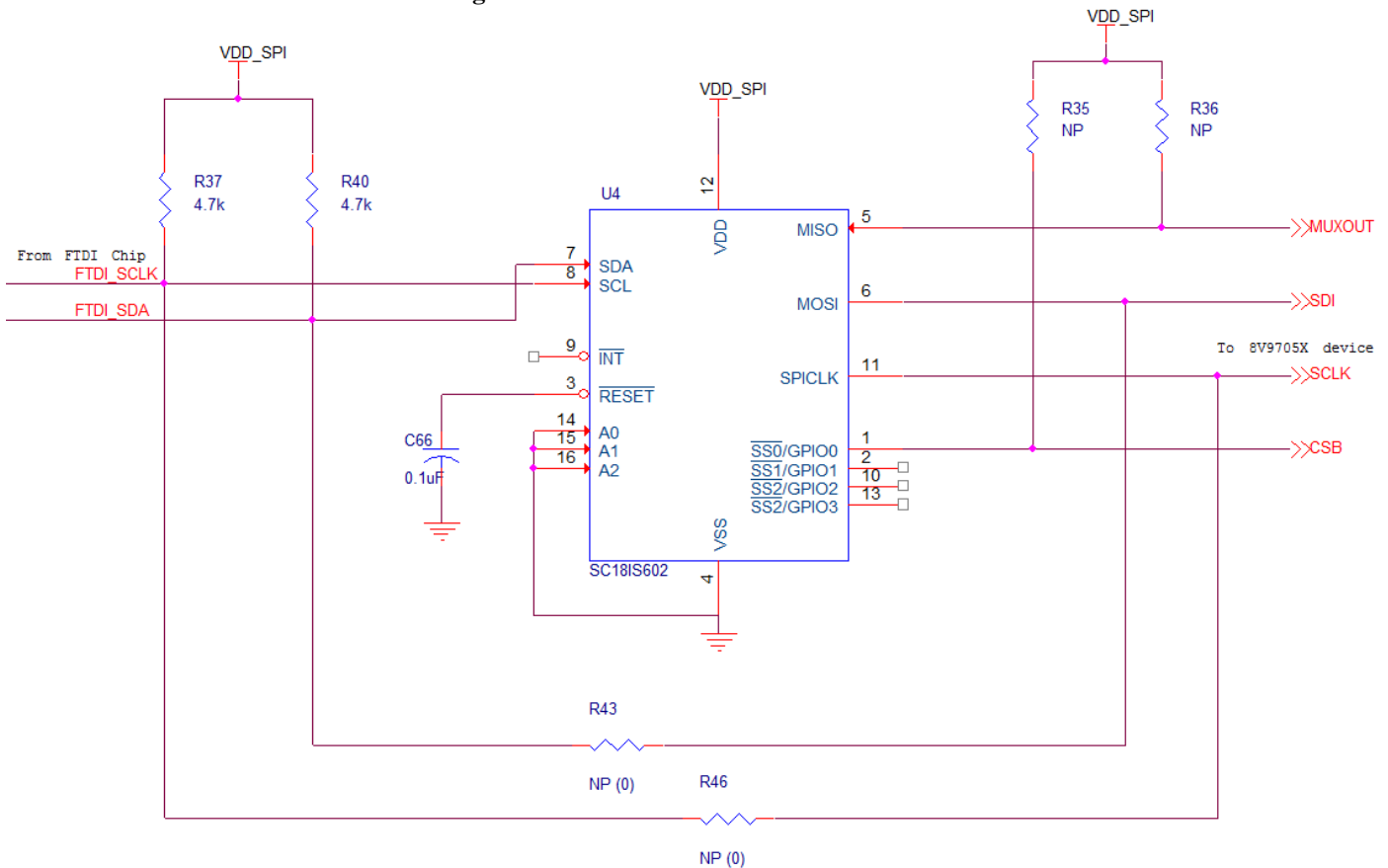
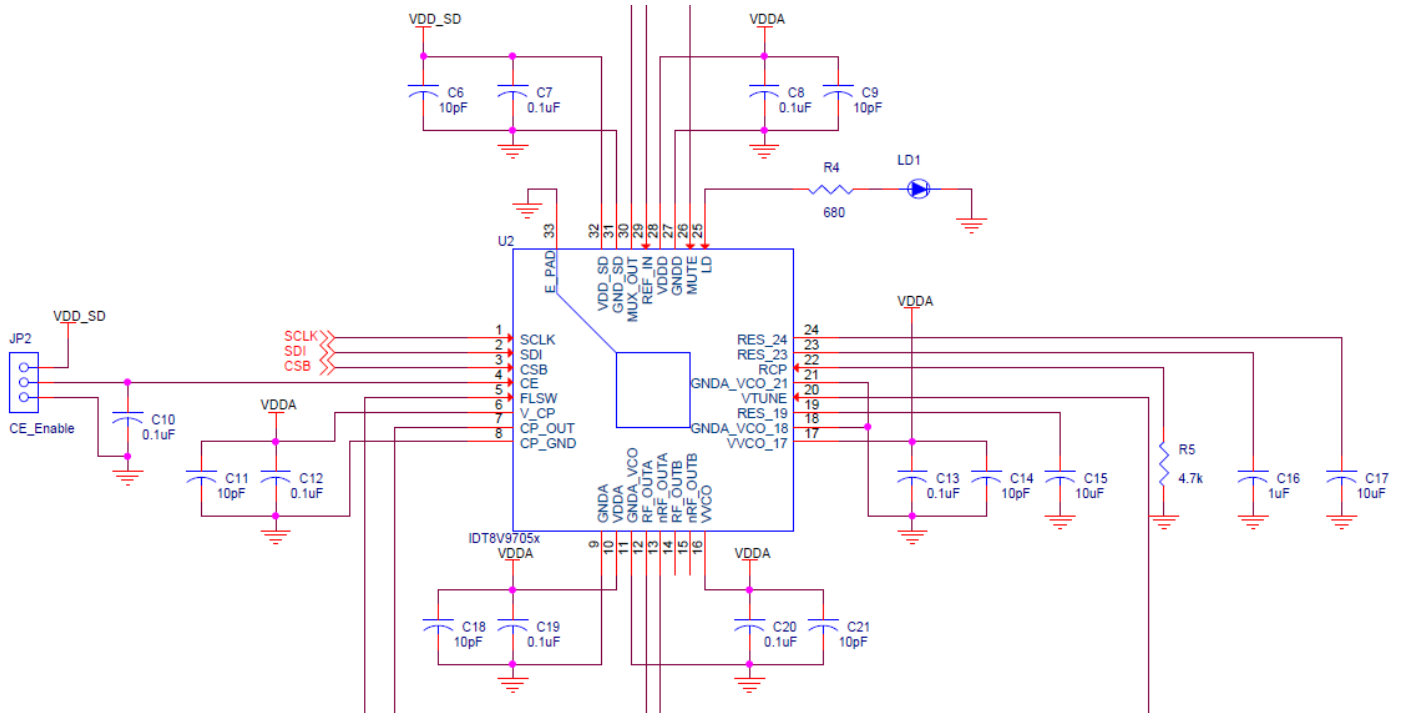

Figure 9. 8V9705x DUT Schematic



## Powering from an External Supply

The evaluation board is by default configured to power through USB. (See JP3 jumper position in Fig. 1). To power the device from an external supply:

- 1) Set JP3 to the position shown in Figure 9.
- 2) Connect an external 4V supply to LDO\_PWR (J6).
- 3) Connect the external supply Ground to GND (J7).

Figure 10. External Power Configuration



## External Signal Reference Configuration

An on-board 25MHz TXCO provides the default source for RF\_IN. In order to evaluate the device using an external signal reference, the following changes must be implemented:

- 1) Remove R20. This powers down the TXCO.
- 2) Remove R1. This disconnects the TXCO from the input path.
- 3) If the external signal can be ac-coupled, then populate C3=0.1uF. For dc termination to ground, C3=0ohm.
- 4) Populate R3=50ohm. This provides a termination for the input signal.
- 5) Replace C4=0.1uF. The input is ac-coupled into the device, which provides its own internal re-bias.
- 6) Connect the external signal reference to J1 using a 50-ohm cable.

Figure 11. External Signal Reference Configuration

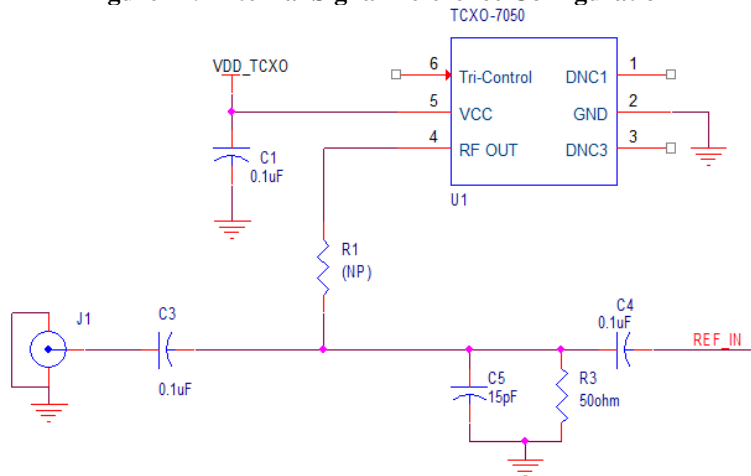

## DC Controls

JP1 MUTE control: RF\_OUTA and RF\_OUTB Power-Down. A logic low on this pin mutes the RF\_OUT outputs and puts them in High-Impedance. This function is also SPI controllable and in this case also allows the power down of either RF\_OUTA or RF\_OUTB. This jumper can be left floating for normal operation.

JP2 Chip Enable: Powers down the device on logic Low, with charge pump put into a High-Impedance mode. Powers up the device on logic High. This jumper can be left floating for normal operation.

For more questions or support, feel free to contact us at [clocks@idt.com](mailto:clocks@idt.com)



## Notice

1. Descriptions of circuits, software and other related information in this document are provided only to illustrate the operation of semiconductor products and application examples. You are fully responsible for the incorporation or any other use of the circuits, software, and information in the design of your product or system. Renesas Electronics disclaims any and all liability for any losses and damages incurred by you or third parties arising from the use of these circuits, software, or information.
2. Renesas Electronics hereby expressly disclaims any warranties against and liability for infringement or any other claims involving patents, copyrights, or other intellectual property rights of third parties, by or arising from the use of Renesas Electronics products or technical information described in this document, including but not limited to, the product data, drawings, charts, programs, algorithms, and application examples.
3. No license, express, implied or otherwise, is granted hereby under any patents, copyrights or other intellectual property rights of Renesas Electronics or others.
4. You shall not alter, modify, copy, or reverse engineer any Renesas Electronics product, whether in whole or in part. Renesas Electronics disclaims any and all liability for any losses or damages incurred by you or third parties arising from such alteration, modification, copying or reverse engineering.
5. Renesas Electronics products are classified according to the following two quality grades: "Standard" and "High Quality". The intended applications for each Renesas Electronics product depends on the product's quality grade, as indicated below.
  - "Standard": Computers; office equipment; communications equipment; test and measurement equipment; audio and visual equipment; home electronic appliances; machine tools; personal electronic equipment; industrial robots; etc.
  - "High Quality": Transportation equipment (automobiles, trains, ships, etc.); traffic control (traffic lights); large-scale communication equipment; key financial terminal systems; safety control equipment; etc.Unless expressly designated as a high reliability product or a product for harsh environments in a Renesas Electronics data sheet or other Renesas Electronics document, Renesas Electronics products are not intended or authorized for use in products or systems that may pose a direct threat to human life or bodily injury (artificial life support devices or systems; surgical implantations; etc.), or may cause serious property damage (space system; undersea repeaters; nuclear power control systems; aircraft control systems; key plant systems; military equipment; etc.). Renesas Electronics disclaims any and all liability for any damages or losses incurred by you or any third parties arising from the use of any Renesas Electronics product that is inconsistent with any Renesas Electronics data sheet, user's manual or other Renesas Electronics document.
6. When using Renesas Electronics products, refer to the latest product information (data sheets, user's manuals, application notes, "General Notes for Handling and Using Semiconductor Devices" in the reliability handbook, etc.), and ensure that usage conditions are within the ranges specified by Renesas Electronics with respect to maximum ratings, operating power supply voltage range, heat dissipation characteristics, installation, etc. Renesas Electronics disclaims any and all liability for any malfunctions, failure or accident arising out of the use of Renesas Electronics products outside of such specified ranges.
7. Although Renesas Electronics endeavors to improve the quality and reliability of Renesas Electronics products, semiconductor products have specific characteristics, such as the occurrence of failure at a certain rate and malfunctions under certain use conditions. Unless designated as a high reliability product or a product for harsh environments in a Renesas Electronics data sheet or other Renesas Electronics document, Renesas Electronics products are not subject to radiation resistance design. You are responsible for implementing safety measures to guard against the possibility of bodily injury, injury or damage caused by fire, and/or danger to the public in the event of a failure or malfunction of Renesas Electronics products, such as safety design for hardware and software, including but not limited to redundancy, fire control and malfunction prevention, appropriate treatment for aging degradation or any other appropriate measures. Because the evaluation of microcomputer software alone is very difficult and impractical, you are responsible for evaluating the safety of the final products or systems manufactured by you.
8. Please contact a Renesas Electronics sales office for details as to environmental matters such as the environmental compatibility of each Renesas Electronics product. You are responsible for carefully and sufficiently investigating applicable laws and regulations that regulate the inclusion or use of controlled substances, including without limitation, the EU RoHS Directive, and using Renesas Electronics products in compliance with all these applicable laws and regulations. Renesas Electronics disclaims any and all liability for damages or losses occurring as a result of your noncompliance with applicable laws and regulations.
9. Renesas Electronics products and technologies shall not be used for or incorporated into any products or systems whose manufacture, use, or sale is prohibited under any applicable domestic or foreign laws or regulations. You shall comply with any applicable export control laws and regulations promulgated and administered by the governments of any countries asserting jurisdiction over the parties or transactions.
10. It is the responsibility of the buyer or distributor of Renesas Electronics products, or any other party who distributes, disposes of, or otherwise sells or transfers the product to a third party, to notify such third party in advance of the contents and conditions set forth in this document.
11. This document shall not be reprinted, reproduced or duplicated in any form, in whole or in part, without prior written consent of Renesas Electronics.
12. Please contact a Renesas Electronics sales office if you have any questions regarding the information contained in this document or Renesas Electronics products.

(Note1) "Renesas Electronics" as used in this document means Renesas Electronics Corporation and also includes its directly or indirectly controlled subsidiaries.

(Note2) "Renesas Electronics product(s)" means any product developed or manufactured by or for Renesas Electronics.

(Rev.4.0-1 November 2017)

## Corporate Headquarters

TOYOSU FORESIA, 3-2-24 Toyosu,  
Koto-ku, Tokyo 135-0061, Japan  
[www.renesas.com](http://www.renesas.com)

## Contact Information

For further information on a product, technology, the most up-to-date version of a document, or your nearest sales office, please visit:  
[www.IDT.com/go/support](http://www.IDT.com/go/support)

## Trademarks

Renesas and the Renesas logo are trademarks of Renesas Electronics Corporation. All trademarks and registered trademarks are the property of their respective owners.



**Стандарт  
Электрон  
Связь**

Мы молодая и активно развивающаяся компания в области поставок электронных компонентов. Мы поставляем электронные компоненты отечественного и импортного производства напрямую от производителей и с крупнейших складов мира.

Благодаря сотрудничеству с мировыми поставщиками мы осуществляем комплексные и плановые поставки широчайшего спектра электронных компонентов.

Собственная эффективная логистика и склад в обеспечивает надежную поставку продукции в точно указанные сроки по всей России.

Мы осуществляем техническую поддержку нашим клиентам и предпродажную проверку качества продукции. На все поставляемые продукты мы предоставляем гарантию .

Осуществляем поставки продукции под контролем ВП МО РФ на предприятия военно-промышленного комплекса России , а также работаем в рамках 275 ФЗ с открытием отдельных счетов в уполномоченном банке. Система менеджмента качества компании соответствует требованиям ГОСТ ISO 9001.

Минимальные сроки поставки, гибкие цены, неограниченный ассортимент и индивидуальный подход к клиентам являются основой для выстраивания долгосрочного и эффективного сотрудничества с предприятиями радиоэлектронной промышленности, предприятиями ВПК и научно-исследовательскими институтами России.

С нами вы становитесь еще успешнее!

**Наши контакты:**

**Телефон:** +7 812 627 14 35

**Электронная почта:** [sales@st-electron.ru](mailto:sales@st-electron.ru)

**Адрес:** 198099, Санкт-Петербург,  
Промышленная ул, дом № 19, литера Н,  
помещение 100-Н Офис 331