

I²C Precision Altimeter

The MPL3115A2 employs a MEMS pressure sensor with an I²C interface to provide accurate Pressure/Altitude and Temperature data. The sensor outputs are digitized by a high resolution 24-bit ADC. Internal processing removes compensation tasks from the host MCU system. Multiple user-programmable, power saving, interrupt and autonomous data acquisition modes are available, including programmed acquisition cycle timing, and poll-only modes. Typical active supply current is 40 μ A per measurement-second for a stable 30 cm output resolution. Pressure output can be resolved with output in fractions of a Pascal, and Altitude can be resolved in fractions of a meter.

The MPL3115A2 is offered in a 5 mm by 3 mm by 1.1 mm LGA package and specified for operation from -40°C to 85°C. Package is surface mount with a stainless steel lid and is RoHS compliant.

Features

- 1.95V to 3.6V Supply Voltage, internally regulated by LDO
- 1.6V to 3.6V Digital Interface Supply Voltage
- Fully Compensated internally
- Direct Reading, Compensated
 - Pressure: 20-bit measurement (Pascals)
 - Altitude: 20-bit measurement (meters)
 - Temperature: 12-bit measurement (degrees Celsius)
- Programmable Events
- Autonomous Data Acquisition
- Resolution down to 1 ft. / 30 cm
- 32 Sample FIFO
- Ability to log data up to 12 days using the FIFO
- 1 second to 9 hour data acquisition rate
- I²C digital output interface (operates up to 400 kHz)

Application Examples

- High Accuracy Altimetry
- Smartphones/Tablets
- Personal Electronics Altimetry
- GPS Dead Reckoning
- GPS Enhancement for Emergency Services
- Map Assist, Navigation
- Weather Station Equipment

MPL3115A2

50 to 110 kPa

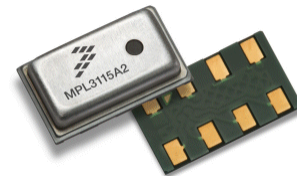

LGA PACKAGE

5.0 mm by 3.0 mm by 1.1 mm

Top View

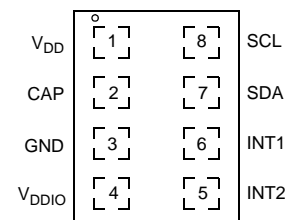

Pin Connections

ORDERING INFORMATION

| Device Name | Package Options | Case No. | # of Ports | | | Pressure Type | | | Digital Interface |
|-------------|--------------------|----------|------------|--------|------|---------------|--------------|----------|-------------------|
| | | | None | Single | Dual | Gauge | Differential | Absolute | |
| MPL3115A2 | Tray | 2153 | • | | | | | • | • |
| MPL3115A2R1 | Tape & Reel (1000) | 2153 | • | | | | | • | • |

This document contains information on a new product. Specifications and information herein are subject to change without notice.

Contents

| | | |
|----------|---|-----------|
| 1 | Block Diagram and Pin Descriptions | 3 |
| 2 | Mechanical and Electrical Specifications | 5 |
| 2.1 | Mechanical Characteristics | 5 |
| 3 | Electrical Characteristics | 6 |
| 3.1 | I ² C Interface Characteristics | 7 |
| 3.2 | Absolute Maximum Ratings | 9 |
| 4 | Quick Start Quick Setup Guide | 10 |
| 5 | Terminology | 14 |
| 5.1 | Resolution | 14 |
| 5.2 | Accuracy | 14 |
| 5.3 | Pressure/Altitude | 14 |
| 5.4 | Power Modes of Operation | 15 |
| 6 | Functionality | 15 |
| 6.1 | Factory Calibration | 16 |
| 6.2 | Barometer/Altimeter Function | 16 |
| 6.3 | Temperature Function | 16 |
| 6.4 | Autonomous Data Acquisition | 16 |
| 6.5 | FIFO | 16 |
| 6.6 | External Interrupts | 16 |
| 6.7 | Pressure/Altitude and Temperature Delta | 17 |
| 6.8 | Min/Max Data Value Storage | 17 |
| 6.9 | Digital Interface | 17 |
| 7 | Register Descriptions | 19 |
| 7.1 | Sensor Status | 21 |
| 7.2 | Device ID | 25 |
| 7.3 | FIFO Setup | 25 |
| 7.4 | Time Delay Register | 27 |
| 7.5 | System Mode Register | 27 |
| 7.6 | System Interrupt Status | 27 |
| 7.7 | Sensor Data | 28 |
| 7.8 | Barometric Pressure Input | 29 |
| 7.9 | Pressure/Altitude Target | 29 |
| 7.10 | Temperature Target | 29 |
| 7.11 | Pressure/Altitude Window | 30 |
| 7.12 | Temperature Window | 30 |
| 7.13 | Minimum Pressure | 30 |
| 7.14 | Maximum Pressure | 31 |
| 7.15 | Minimum Temperature | 31 |
| 7.16 | Maximum Temperature | 32 |
| 7.17 | Control Registers | 32 |
| 7.18 | Offset Correction | 37 |
| 8 | Soldering/Landing Pad Information | 39 |
| 9 | Tape and Reel Specifications | 42 |

Related Documentation

The MPL3115A2 device features and operations are described in a variety of reference manuals, user guides, and application notes. To find the most-current versions of these documents:

1. Go to the Freescale homepage at:
<http://www.freescale.com/>
2. In the Keyword search box at the top of the page, enter the device number MPL3115A2.
3. In the Refine Your Result pane on the left, click on the Documentation link.

1 Block Diagram and Pin Descriptions

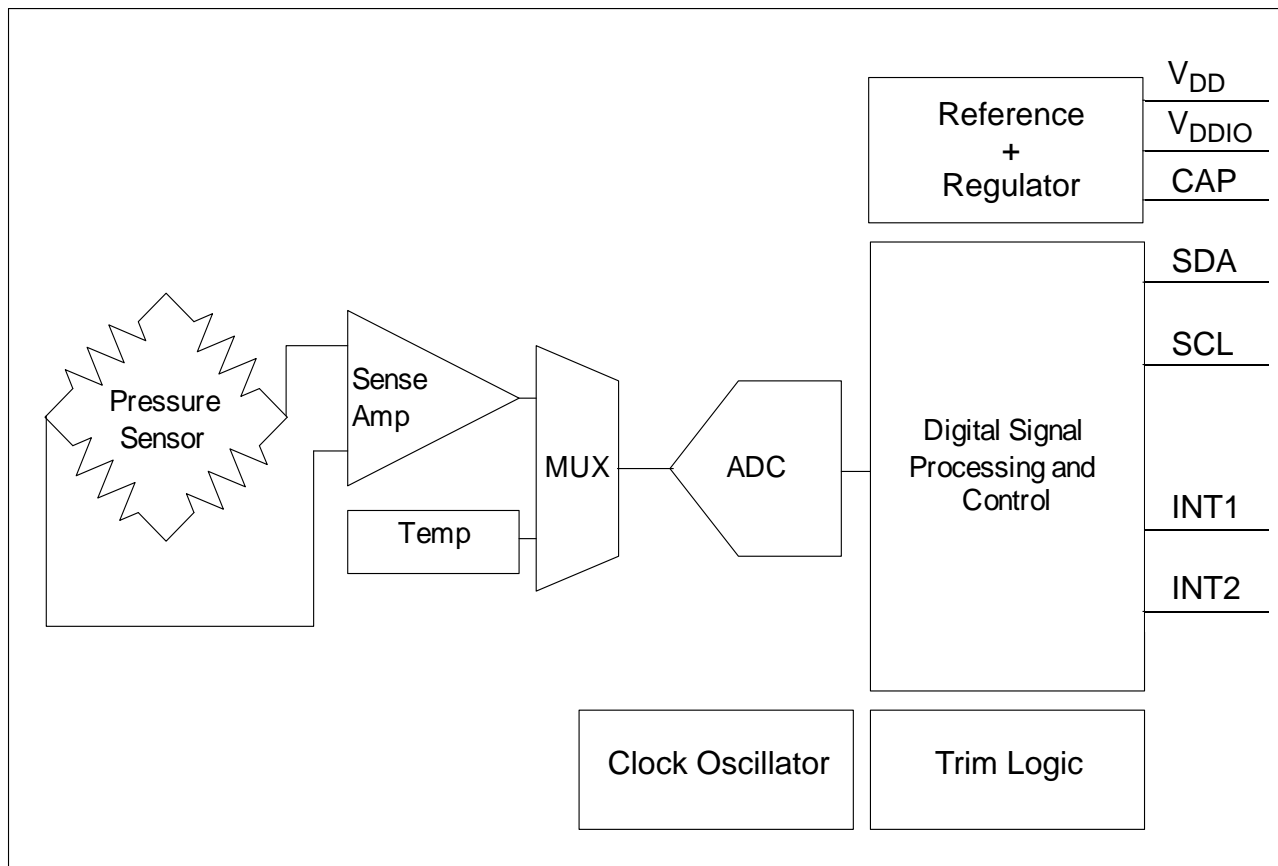

Figure 1. Block Diagram

Table 1. Pin Descriptions

| Pin | Name | Function |
|-----|-------------------|---|
| 1 | V _{DD} | V _{DD} Power Supply Connection (1.95-3.6V) |
| 2 | CAP | External Capacitor |
| 3 | GND | Ground |
| 4 | V _{DDIO} | Digital Interface Power Supply (1.62-3.6V) |
| 5 | INT2 | Pressure Interrupt 2 |
| 6 | INT1 | Pressure Interrupt 1 |
| 7 | SDA | I ² C Serial Data |
| 8 | SCL | I ² C Serial Clock |

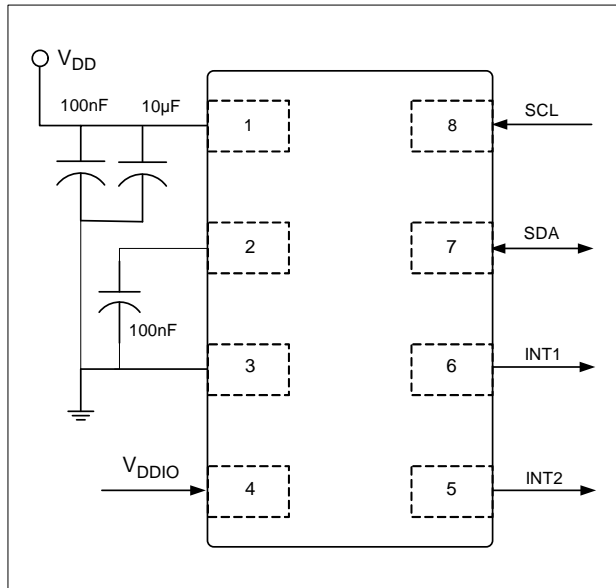

Figure 2. Pin Connections

The device power is supplied through the V_{DD} line. Power supply decoupling capacitors (100 nF ceramic plus 10 μ F bulk or 10 μ F ceramic) should be placed as near as possible to pin 1 of the device. A second 100 nF capacitor is used to bypass the internal regulator. The functions, threshold and the timing of the interrupt pins (INT1 and INT2) are user programmable through the I²C interface.

2 Mechanical and Electrical Specifications

2.1 Mechanical Characteristics

Table 2. Mechanical Characteristics @ $V_{DD} = 2.5V$, $T = 25^{\circ}C$ unless otherwise noted⁽¹⁾

| Ref | Symbol | Parameter | Test Conditions | Min | Typ | Max | Unit |
|---------------------------|-----------------|---|--|--------|-------|-----|--------|
| Pressure Sensor | | | | | | | |
| 1 | P _{FS} | Measurement Range | Calibrated Range | 50 | | 110 | kPa |
| | | | Operational Range | 20 | | 110 | kPa |
| 2 | | Pressure Reading Noise | 1x Oversample ⁽²⁾ | | 19 | | Pa RMS |
| | | | 128x Oversample ⁽²⁾ | | 1.5 | | Pa RMS |
| 3 | | Pressure Absolute Accuracy | 50 to 110 kPa over 0°C to 50°C | -0.4 | | 0.4 | kPa |
| | | | 50 to 110 kPa over -10°C to 70°C | | ±0.4 | | |
| 4 | | Pressure Relative Accuracy | Relative accuracy during pressure change between 70 to 110 kPa at any constant temperature between -10°C to 50°C | | ±0.05 | | kPa |
| | | | Relative accuracy during changing temperature between -10°C to 50°C at any constant pressure between 50 kPa to 110 kPa | | ±0.1 | | |
| 5 | | Pressure/Altitude Resolution ⁽³⁾⁽⁴⁾⁽⁵⁾ | Barometer Mode | 0.25 | 1.5 | | Pa |
| | | | Altimeter Mode | 0.0625 | 0.3 | | m |
| 6 | | Output Data Rate | OST ⁽⁶⁾ Mode | | 100 | | Hz |
| | | | FIFO Mode | | | 1 | Hz |
| Temperature Sensor | | | | | | | |
| 7 | T _{FS} | Measurement Range | | -40 | | +85 | °C |
| 8 | | Temperature Accuracy | @ 25°C | | ±1 | | °C |
| | | | Over Temperature Range | | ±3 | | |
| 9 | T _{OP} | Operating Temperature Range | | -40 | | +85 | °C |
| 10 | | Board Mount Drift | After solder reflow | | ±0.15 | | kPa |
| 11 | | Long Term Drift | After a period of 1 year | | ±0.1 | | kPa |

1. Measured at 25°C, over 50 kPa to 110 kPa.
2. Oversample (OSR) modes internally combine and average samples to reduce noise.
3. Smallest bit change in register represents minimum value change in Pascals or meters. Typical resolution to signify change in altitude is 0.3m.
4. At 128x Oversample Ratio.
5. Reference pressure = 101.325 kPa (Sea Level).
6. OST = One Shot Mode.

3 Electrical Characteristics

Table 3. Electrical Characteristics @ VDD = 2.5V, T = 25°C unless otherwise noted.

| Ref | Symbol | Parameter | Test Conditions | Min | Typ | Max | Unit |
|---|---------------------|---|--|------|-----|------|-------------------|
| 1 | V _{DDIO} | I/O Supply Voltage | | 1.62 | 1.8 | 3.6 | V |
| 2 | V _{DD} | Operating Supply Voltage | | 1.95 | 2.5 | 3.6 | V |
| 3 | I _{DD} | Integrated Current 1 update per second | Highest Speed Mode Oversample = 1 | | 8.5 | | μA |
| 4 | | | Standard Mode Oversample = 16 | | 40 | | |
| 5 | | | High Resolution Mode Oversample = 128 | | 265 | | |
| 6 | I _{DDMAX} | Max Current during Acquisition and Conversion | During Acquisition | | 2 | | mA |
| 7 | I _{DDSTBY} | Supply Current Drain in STANDBY Mode | STANDBY Mode selected SBYB = 0 | | 2 | | μA |
| 8 | V _{IH} | Digital High Level Input Voltage SCL, SDA | | 0.75 | | | V _{DDIO} |
| 9 | V _{IL} | Digital Low Level Input Voltage SCL, SDA | | | | 0.3 | V _{DDIO} |
| 10 | V _{OH} | High Level Output Voltage INT1, INT2 | I _O = 500 μA | 0.9 | | | V _{DDIO} |
| 11 | V _{OL} | Low Level Output Voltage INT1, INT2 | I _O = 500 μA | | | 0.1 | V _{DDIO} |
| 12 | V _{OLS} | Low Level Output Voltage SDA | I _O = 500 μA | | | 0.1 | V _{DDIO} |
| 14 | T _{ON} | Turn-on time ⁽¹⁾ | Highest Speed Mode ⁽²⁾ | | | 60 | ms |
| | | | Highest Resolution Mode ⁽³⁾ | | | 1000 | |
| 16 | T _{OP} | Operating Temperature Range | | -40 | 25 | +85 | °C |
| I²C Addressing | | | | | | | |
| MPL3115A2 uses 7-bit addressing and does not acknowledge general call address 000 0000. Slave address has been set to 0x60 or 110 0000. 8-bit read is 0xC1, 8-bit write is 0xC0 | | | | | | | |

1. Time to obtain valid data from "STANDBY" mode to "ACTIVE" mode.
2. High Speed mode is achieved by setting the oversample rate of 1x.
3. High Resolution mode is achieved by setting the oversample to 128x.

3.1 I²C Interface Characteristics

Table 4. I²C Slave Timing Values⁽¹⁾

| Ref | Symbol | Parameter | I ² C | | | Unit |
|-----|---------------------|--|---|---------------------------------------|-----|------|
| | | | Condition | Min | Max | |
| 1 | f _{SCL} | SCL Clock Frequency | Pull-up = 1 kΩ, C _b = 400 pF | 0 | 400 | KHz |
| 2 | f _{SCL} | SCL Clock Frequency | Pull-up = 1 kΩ, C _b = 20 pF | 0 | 4 | MHz |
| 3 | t _{BUF} | Bus free time between STOP and START condition | | 1.3 | | μs |
| 4 | t _{HD;STA} | Repeated START Hold Time | | 0.6 | | μs |
| 5 | t _{SU;STA} | Repeated START Setup Time | | 0.6 | | μs |
| 6 | t _{SU;STO} | STOP Condition Setup Time | | 0.6 | | μs |
| 7 | t _{HD;DAT} | SDA Data Hold Time ⁽²⁾ | | 50 ⁽³⁾ | (4) | ns |
| 8 | t _{SU;DAT} | SDA Setup Time | | 100 ⁽⁵⁾ | | ns |
| 9 | t _{LOW} | SCL Clock Low Time | | 1.3 | | μs |
| 10 | t _{HIGH} | SCL Clock High Time | | 0.6 | | μs |
| 11 | t _r | SDA and SCL Rise Time | | 20 + 0.1C _b ⁽⁶⁾ | 300 | ns |
| 12 | t _f | SDA and SCL Fall Time ⁽³⁾⁽⁶⁾⁽⁷⁾⁽⁸⁾ | | 20 + 0.1C _b ⁽⁶⁾ | 300 | ns |
| 13 | t _{SP} | Pulse width of spikes that are suppressed by internal input filter | | | 50 | ns |

- All values referred to VIH(min) and VIL(max) levels.
- t_{HD;DAT} is the data hold time that is measured from the falling edge of SCL, applies to data in transmission and the acknowledge.
- The device must internally provide a hold time of at least 300 ns for the SDA signal (with respect to the VIH(min) of the SCL signal) to bridge the undefined region of the falling edge of SCL.
- The maximum t_{HD;DAT} must be less than the maximum of t_{VD;DAT} or t_{VD;ACK} by a transition time. This device does not stretch the LOW period (t_{LOW}) of the SCL signal.
- A fast mode I²C device can be used in a standard mode I²C system, but the requirement t_{SU;DAT} 250 ns must then be met. This will automatically be the case if the device does not stretch the LOW period of the SCL signal. If such a device does stretch the LOW period of the SCL signal, it must output the next data bit to the SDA line t_{r(max)} + t_{SU;DAT} = 1000 + 250 = 1250 ns (according to the standard mode I²C specification) before the SCL line is released. Also the acknowledge timing must meet this set-up time.
- C_b = Total capacitance of one bus line in pF.
- The maximum t_r for the SDA and SCL bus lines is specified at 300 ns. The maximum fall time for the SDA output stage t_f is specified at 250 ns. This allows series protection resistors to be connected in between the SDA and the SCL pins and the SDA/SCL bus lines without exceeding the maximum specified t_f.
- In Fast Mode Plus, fall time is specified the same for both output stage and bus timing. If series resistors are used, designers should allow for this when considering bus timing.

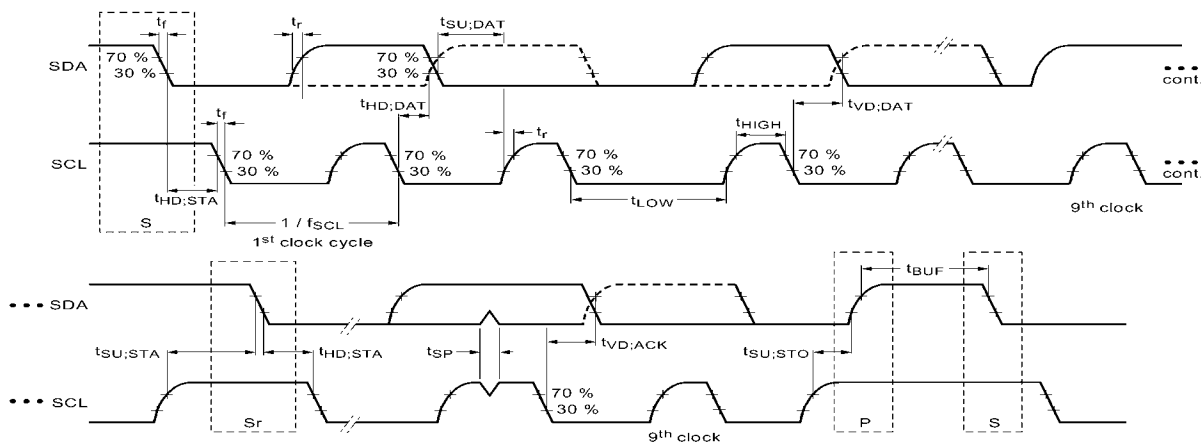

Figure 3. I²C Slave Timing Diagram

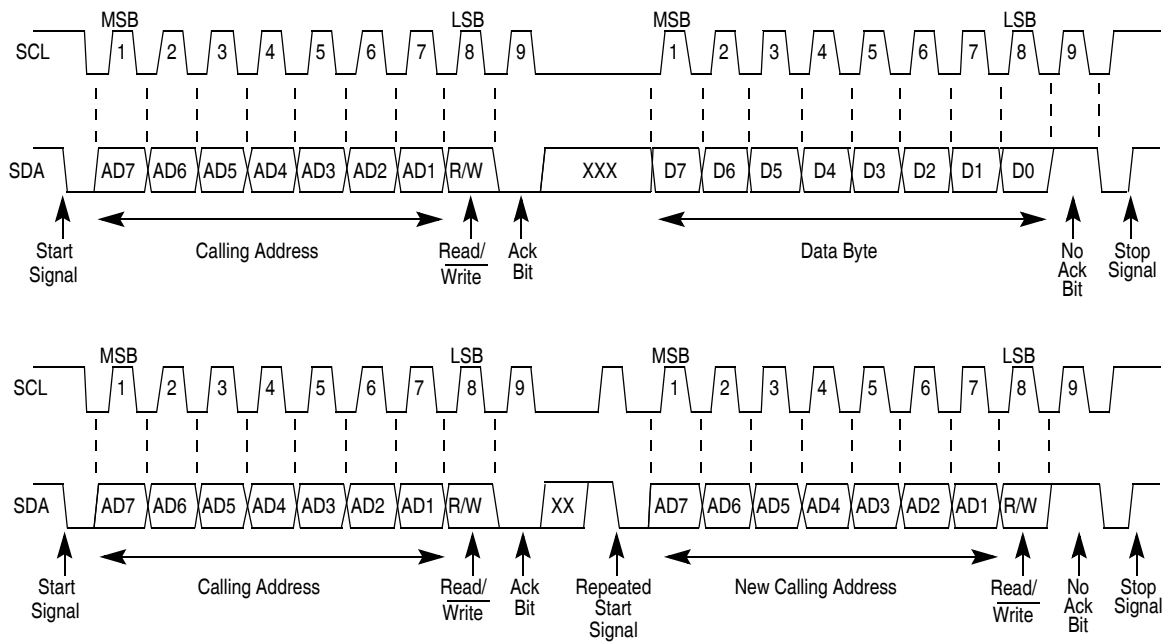

Figure 4. I²C Bus Transmission Signals

3.2 Absolute Maximum Ratings

Stresses above those listed as “absolute maximum ratings” may cause permanent damage to the device. This is a stress rating only and functional operation of the device under these conditions is not implied. Exposure to maximum rating conditions for extended periods may affect device reliability.

Table 5. Maximum Ratings

| Characteristic | Symbol | Value | Unit |
|---|------------|--------------------------|------|
| Maximum Applied Pressure | P_{max} | 500 | kPa |
| Supply Voltage | V_{DD} | -0.3 to 3.6 | V |
| Interface Supply Voltage | V_{DDIO} | -0.3 to 3.6 | V |
| Input Voltage on any Control Pin (SCL, SDA) | V_{IN} | -0.3 to $V_{DDIO} + 0.3$ | V |
| Operating Temperature Range | T_{OP} | -40 to +85 | °C |
| Storage Temperature Range | T_{STG} | -40 to +125 | °C |

Table 6. ESD And Latch-up Protection Characteristics

| Rating | Symbol | Value | Unit |
|--|--------|-------|------|
| Human Body Model | HBM | ±2000 | V |
| Machine Model | MM | ±200 | V |
| Charge Device Model | CDM | ±500 | V |
| Latch-up Current at $T = 85^{\circ}\text{C}$ | — | ±100 | mA |



This is a mechanical shock sensitive device, improper handling can cause permanent damage to the part or cause the part to otherwise fail.



This is an ESD sensitive device, improper handling can cause permanent damage to the part.

4 Quick Start Quick Setup Guide

The quick setup guide shows how to put the part in Altimeter mode with an OSR of 128. You may then select your data retrieval method between polling, interrupt or FIFO. The following routines are used:

```
/******\  
* IIC Write Register  
*****\  
void IIC_RegWrite(byte address, byte reg,byte val)  
{  
    IICC_TX = 1; // Transmit Mode  
    IIC_Start(); // Send Start  
    IIC_CycleWrite(address); // Send IIC "Write" Address  
    IIC_CycleWrite(reg); // Send Register  
    IIC_CycleWrite(val); // Send Value  
    IIC_Stop(); // Send Stop  
}  
/******\  
* IIC Read Register  
*****\  
byte IIC_RegRead(byte address, byte reg)  
{  
    byte b;  
    IICC_TX = 1; // Transmit Mode  
    IIC_Start(); // Send Start  
    IIC_CycleWrite(address); // Send IIC "Write" Address  
    IIC_CycleWrite(reg); // Send Register  
    IIC_RepeatStart(); // Send Repeat Start  
    IIC_CycleWrite(address+1); // Send IIC "Read" Address  
    b = IIC_CycleRead(1); // *** Dummy read: reads  
    // "IIC_ReadAddress" value ***  
    b = IIC_StopRead(); // Send Stop Read Command IICD  
    return b;  
}  
  
/******\  
* IIC Read Multiple Registers  
*****\  
void IIC_RegReadN(byte address, byte reg1,byte N,byte *array)  
{  
    byte b;  
    IICC_TX = 1; // Transmit Mode  
    IIC_Start(); // Send Start  
    IIC_CycleWrite(address); // Send IIC "Write" Address  
    IIC_CycleWrite(reg1); // Send Register  
    IIC_RepeatStart(); // Send Repeat Start  
    IIC_CycleWrite(address+1); // Send IIC "Read" Address  
    b = IIC_CycleRead(N); // *** Dummy read: reads  
    // "IIC_ReadAddress" value ***
```

```

while (N>1) // Read N-1 Register Values
{
  N--;
  b = IIC_CycleRead(N);
  *array = b;
  array++;

}
b = IIC_StopRead(); // Send Stop Read which returns the
// IICD

*array = b;
}

/*****\
* Initiate IIC Start Condition
\*****/
void IIC_Start(void)
{
  IICC_MST = 1;
  timeout = 0;
  while ( (!IICS_BUSY) && (timeout<1000))
    timeout++;
  if (timeout >= 1000)
    error |= 0x01;
} //*** Wait until BUSY=0

/*****\
* Initiate IIC Stop Condition
\*****/
byte IIC_StopRead(void)
{
  IICC_MST = 0;
  timeout = 0;
  while ( (IICS_BUSY) && (timeout<1000))
    timeout++;
  if (timeout >= 1000)
    error |= 0x02;

  return IICD;
} //*** Wait until BUSY=0

```

For further information and examples please read application note AN4519 Data Manipulation and Basic Settings of the MPL3115A2 Command Line Interface.

Flow chart for Polling or Interrupt - No FIFO

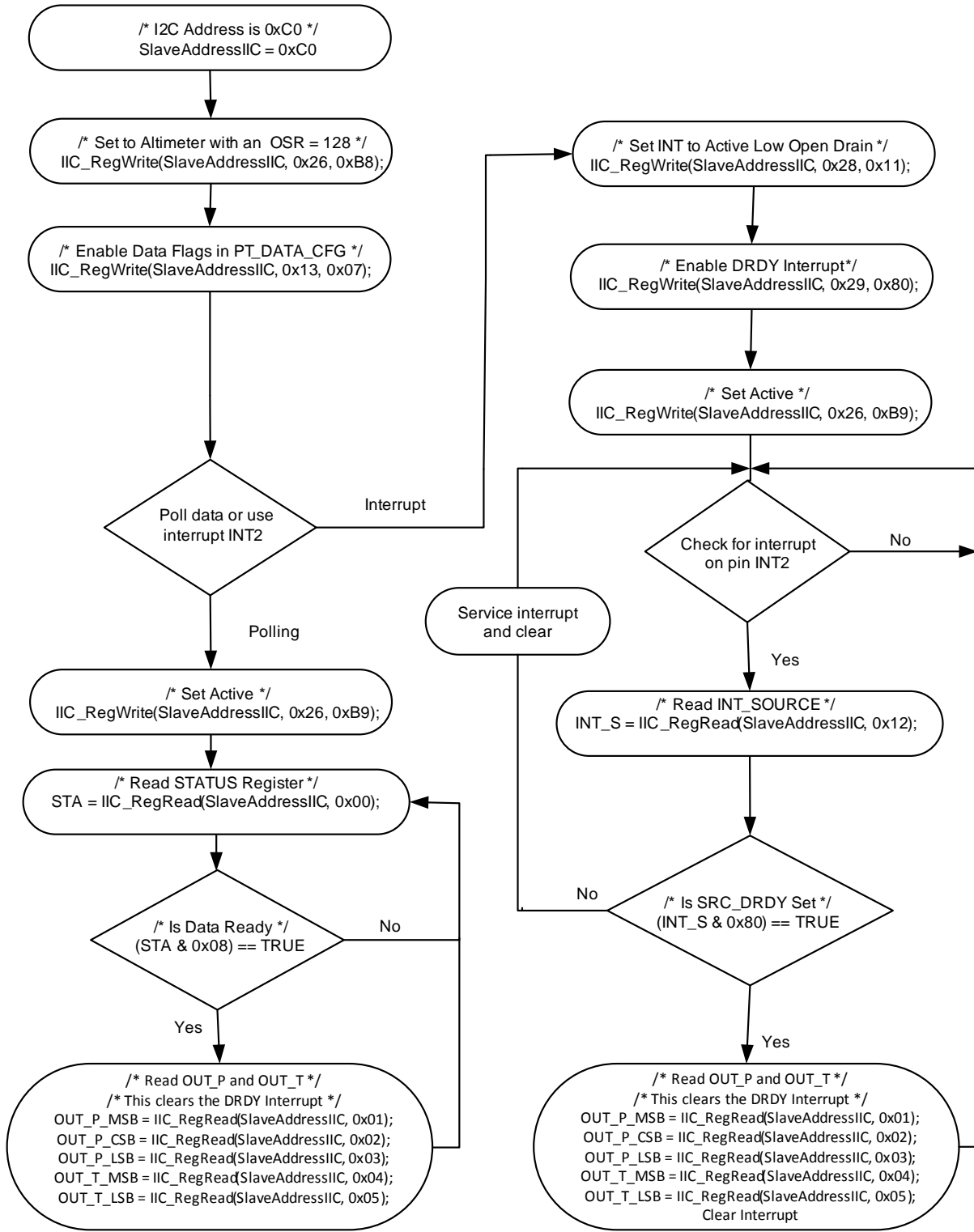

Figure 5. Polling or Interrupt - No FIFO

Flow chart for FIFO setup

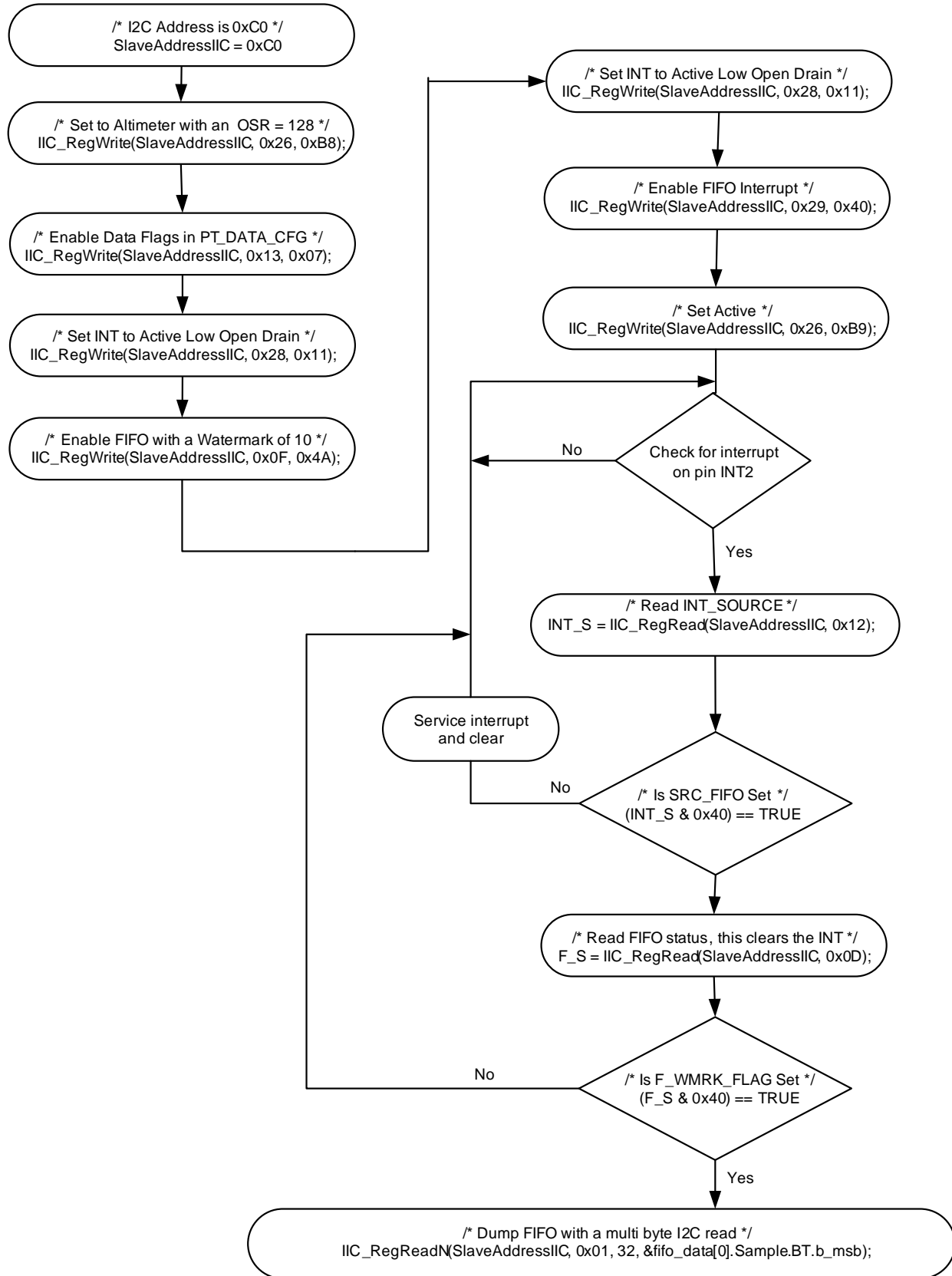

Figure 6. FIFO Setup

5 Terminology

5.1 Resolution

The resolution of a pressure sensor is the minimum change of pressure that can be reliably measured. The usable resolution of the MPL3115A2 is programmable, enabling the user to choose a compromise between acquisition speed, power consumption, and resolution that best fits the application. To simplify the programming, the data is always reported in the same format with differing number of usable bits.

5.2 Accuracy

5.2.1 Offset

The offset is defined as the output signal obtained when the Reference Pressure (a vacuum for an absolute pressure sensor) is applied to the sensor. Offset error affects *absolute pressure* measurements but not *relative pressure* measurements. An *altitude measurement* is the pressure value in comparison to sea level, a Barometric measurement is the pressure value read by the sensor, i.e. a measurement of total pressure seen (e.g. 70 kPa), or total height (e.g. 3000m) above sea level. A change in the offset will affect the pressure value or height seen above sea level as it shifts the sea level 'base reference'. An *absolute pressure measurement* is not the same as *relative pressure measurement*, where the pressure is compared when raising or lowering pressure in shorter intervals. This would be a walk up a hill, measuring the pressure and altitude difference from start to finish. In the relative case, the offset shifts are shared in the two absolute measurements and negate each other during the pressure calculation. For the MPL3115A2, the long term offset shift can be removed by adjusting the pressure or altitude offset correction. This adjustment is provided to override the factory programmed values to compensate for offsets introduced by manufacturing and mounting stresses. It is highly recommended that this is utilized to realize the full accuracy potential of the device.

5.2.2 Linearity

Linearity compares the slope of the measurement data to that of an ideal transfer function. It refers to how well a transducer's output follows the equation $P_{out} = P_{off} + \text{Sensitivity} \times P$ straight line equation over the operating pressure range. The method used by Freescale to give the linearity spec is the end-point straight line method measured at midrange pressure.

5.2.3 Absolute Pressure

Absolute pressure sensors measure an external pressure relative to a zero-pressure reference (vacuum) sealed inside the reference chamber of the die during manufacturing. This standard allows comparison to a standard value set such that 14.7 psi = 101325 Pa = 1 atm at sea level as a measurement target. The absolute pressure is used to determine altitude as it has a constant reference for comparison. Measurement at sea level can be compared to measurement at a mountain summit as they use the same vacuum reference. The conversion of absolute pressure to altitude in meters is calculated based on US Standard Atmosphere 1976 (NASA). Note that absolute pressure is not linear in nature to altitude; it is an exponential function. The value of altitude, in increments of 0.0625 meters, can be read directly from the MPL3115A2, or the value of pressure in 0.25 Pascal (Pa) units.

5.2.4 Span

Span is the value of full scale output with offset subtracted, representing the full range of the pressure sensor. Ideally the span is a specification over a constant temperature. The MPL3115A2 uses internal temperature compensation to remove drift. Span accuracy is the comparison of the measured difference and the actual difference between the highest and lowest pressures in the specified range.

5.3 Pressure/Altitude

The MPL3115A2 device is a high accuracy pressure sensor with integrated data calculation and logging capabilities. The altitude calculations are based on the measured pressure, the user input of the equivalent sea level pressure (to compensate for local weather conditions) and the US Standard Atmosphere 1976 (NASA) to give the altitude readings. Pressure is given in Pascals (Pa), and fractions of a Pa. Altitude is given in meters (m) and fractions of a meter. The altitude is calculated from the pressure using the equation below:

$$h = 44330.77 \left\{ 1 - \left(p/p_0 \right)^{0.1902632} \right\} + \text{OFF_H (Register Value)}$$

Where p_0 = sea level pressure (101325 Pa) and h is in meters. The MPL3115A2 uses this value since the offset register is defined as 2 Pascals per LSB.

5.4 Power Modes of Operation

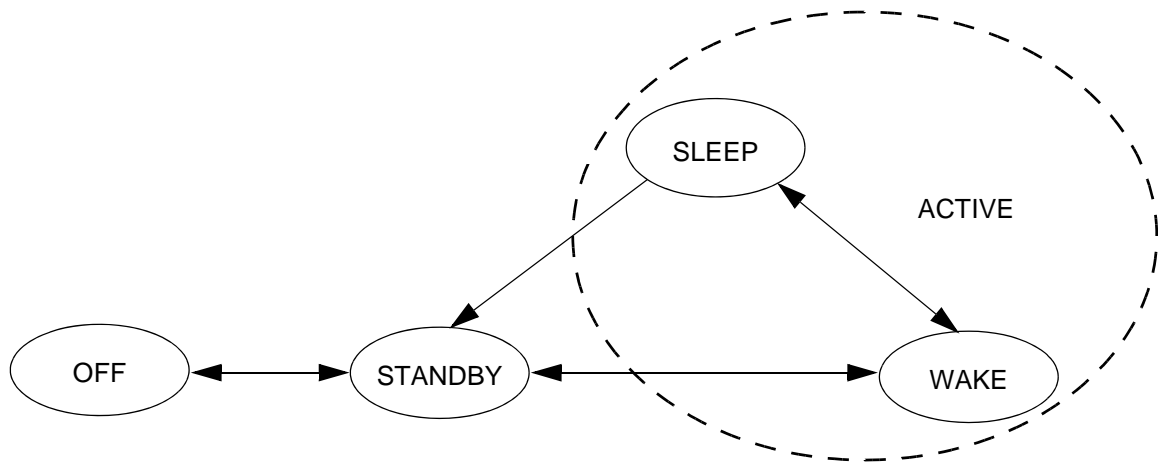

Figure 7. Mode Transition Diagram

5.4.1 Off

Unit is powered down and has no operating functionality. V_{DD} and V_{DDIO} are not powered.

5.4.2 STANDBY

The digital sections are operational and the unit is capable of receiving commands and delivering stored data. The analog sections are off. The part is waiting for CTRL_REG1 to be configured and the part to enter active mode.

5.4.3 ACTIVE

Both analog and digital sections are running. The unit is capable of gathering new data, and accepting commands. MPL3115A2 is fully functional.

Table 7. Mode of Operation Description

| Mode | I ² C Bus State | VDD | | Function Description |
|---------|--|---------|----------------------------------|--|
| OFF | Powered Down | < 1.62V | < VDD + 0.3V | Device is powered off. |
| STANDBY | I ² C Communication with device is possible | ON | SBYB bit of CTRL_REG1 is cleared | Only POR and digital blocks are enabled. Analog subsystem is disabled. |
| ACTIVE | I ² C Communication with device is possible | ON | SBYB bit of CTRL_REG1 is set | All blocks are enabled (POR, digital, analog). |

6 Functionality

The device is a low-power, high accuracy digital output altimeter, barometer and thermometer, packaged in a 3 x 5 x 1.1 mm form factor. The complete device includes a sensing element, analog and digital signal processing and an I²C interface.

The device has two operational modes, barometer and altimeter. Both modes include a thermometer temperature output function.

Power consumption and sensitivity are programmable where the data oversampling ratio can be set to balance current consumption and noise/resolution. Serial Interface Communications is through an I²C interface thus making the device particularly suitable for direct interfacing with a microcontroller. The device features two independently programmable interrupt signals INT1 and INT2. These can be set to generate an interrupt signal when a new set of Pressure/Altitude and Temperature data is available, thereby simplifying data acquisition for the host controller. These interrupt pins can also be configured to generate interrupts when a user programmed set of conditions are met (See section 6.6). Examples are: Interrupt can be triggered when a single new data acquisition is ready, when a desired number of samples are stored within the internal FIFO or when a change of Pressure/Altitude or Temperature is detected.

In RAW mode, the FIFO must be disabled and all other functionality: Alarms, Deltas and other interrupts are disabled.

6.1 Factory Calibration

The device is factory calibrated for sensitivity, offset for both Temperature and Pressure measurements. Trim values are stored, on-chip, in Non-Volatile Memory (NVM). In normal use, further calibration is not necessary; however, in order to realize the highest possible accuracy, the device allows the user to override the factory set offset values after power-up. The user adjustments are stored in volatile registers. The factory calibration values are not affected, and are always used by default on power-up.

6.2 Barometer/Altimeter Function

The mode of operation of the device can be selected as Barometer or Altimeter. The internal sensor gives an absolute pressure signal. The absolute pressure signal is processed to provide a scaled pressure or an altitude, depending on the mode selected. The combination of a high performance sensor and the signal processing enable resolution of pressures below 1 Pa and altitude resolution of better than 1 Ft / 0.3m at sea level.

When in Barometer mode, all pressure related data is reported as 20-bit unsigned data in Pascals. When in Altimeter mode, all pressure data is converted to equivalent altitude, based on the US standard atmosphere and then stored as 20-bit 2's complement value in meters and fractions of a meter.

6.2.1 Barometric Input

In order to accurately determine the altitude by pressure, a facility is provided to input the local barometric pressure correction. The default value is 101,326 Pa since the register is in units of 2 Pascals per LSB.

6.3 Temperature Function

The unit contains a high resolution temperature sensor that provides data to the user via a 16-bit data register, as well as for internal compensation of the pressure sensor.

6.4 Autonomous Data Acquisition

The unit can be programmed to periodically capture Altitude/Pressure and Temperature data. Up to 32 data acquisitions can be stored in the internal FIFO. The interval between acquisitions is programmable from 1 second to 9 hours.

Data: (Up to 32 samples over 12 days). The unit can also be programmed to make a single reading and then go to standby mode.

6.5 FIFO

A 32 sample FIFO is incorporated to minimize the overhead of collecting multiple data samples. The FIFO stores both Temperature and Pressure/Altitude data. The device can be programmed to autonomously collect data at programmed intervals and store the data in the FIFO. FIFO interrupts can be triggered by watermark full or data contention (FIFO GATE) events.

6.6 External Interrupts

Two independent interrupt out pins are provided. The configuration of the pins are programmable (polarity, open drain or push-pull.) Any one of the internal interrupt sources can be routed to either pin.

6.6.1 Reach Target Threshold Pressure/Altitude (SRC_PTH)

The interrupt flag is set on reaching the value stored in the Pressure/Altitude target register. Additionally, a window value provides the ability to signal when the target is nearing from either above or below the value in the Pressure/Altitude target register. When in barometer mode, these values represent pressures rather than altitudes.

Examples:

- Set Altitude alert to 3000m and window value to 100m, interrupt is asserted passing 2900m, 3000m, and 3100m.
- Set Pressure alert to 100.0 kPa and window value to 5 kPa, interrupt can be sent passing 95 kPa, 100 kPa and 105 kPa.

Note: When the window value is set to 0 then the interrupt will only be generated when reaching or crossing the target value.

6.6.2 Reach Window Target Pressure/Altitude (SRC_PW)

The interrupt flag is set when the pressure/altitude value is within the window defined by the following formula:

$$\text{Window} = P_TGT_{\text{MSB,LSB}} \pm P_WND_{\text{MSB,LSB}}$$

Note: No interrupt is generated if the P_WND value is set to 0.

6.6.3 Reach Target Threshold Temperature (SRC_TTH)

Interrupt flag is set on reaching the value stored in the Temperature target register. Additionally a window value provides ability to signal when the target is nearing from either above or below the value in the Temperature target register.

Note: When the window value is set to 0 then the interrupt will only be generated when reaching or crossing the target value.

6.6.4 Reach Window Target Temperature (SRC_TW)

The interrupt flag is set when the temperature value is within the window defined by the following formula:

$$\text{Window} = T_TGT \pm T_WND$$

Note: No interrupt is generated if the T_WND value is set to 0.

6.6.5 Pressure/Altitude Change (SRC_PCHG)

Interrupt flag is set if sequential Pressure/Altitude acquisitions exceed value stored in Pressure/Altitude window value register.

6.6.6 Temperature Change (SRC_TCHG)

Interrupt flag is set if sequential Temperature acquisitions exceed the value stored in Pressure/Altitude window value register.

6.6.7 Data Ready

Interrupt flag is set when new data or a data overwrite event has occurred. PTOW and/or PTDR (DR_STATUS register) must be set for an interrupt to be generated.

6.6.8 FIFO Event

Interrupt flag is set when either an overflow or watermark event has occurred. For more information please see section 7.3.

6.7 Pressure/Altitude and Temperature Delta

Registers show the differences from the last Pressure/Altitude and Temperature samples.

6.8 Min/Max Data Value Storage

Registers record the minimum and maximum Pressure/Altitude and Temperature.

6.9 Digital Interface

The registers embedded inside the device are accessed through an I²C serial interface.

Table 8. Serial Interface Pin Descriptions

| Name | Description |
|------|-------------------------------|
| SCL | I ² C Serial Clock |
| SDA | I ² C Serial Data |

There are two signals associated with the I²C bus: the Serial Clock Line (SCL) and the Serial Data line (SDA). The latter is a bidirectional line used for sending and receiving the data to/from the interface. External pull-up resistors connected to V_{DD} are expected for SDA and SCL. When the bus is free both the lines are high. The I²C interface is compliant with fast mode (400 kHz), and normal mode (100 kHz) I²C standards

6.9.1 I²C Operation

The transaction on the bus is started through a start condition (START) signal. START condition is defined as a HIGH to LOW transition on the data line while the SCL line is held HIGH. After START has been transmitted by the master, the bus is considered busy. The next byte of data transmitted after START contains the slave address in the first 7 bits, and the eighth bit tells whether the master is receiving data from the slave or transmitting data to the slave. When an address is sent, each device in the system compares the first seven bits after a start condition with its address. If they match, the device considers itself addressed by the master. The ninth clock pulse, following the slave address byte (and each subsequent byte) is the acknowledge (ACK). The transmitter must release the SDA line during the ACK period. The receiver must then pull the data line low so that it remains stable low during the high period of the acknowledge clock period.

The number of bytes per transfer is unlimited. If the master can't receive another complete byte of data until it has performed some other function, it can hold the clock line, SCL low to force the transmitter into a wait state. Data transfer only continues when the master is ready for another byte and releases the clock line.

A low to high transition on the SDA line while the SCL line is high is defined as a stop condition (STOP). A data transfer is always terminated by a STOP. A master may also issue a repeated START during a data transfer. Device expects repeated STARTs to be used to randomly read from specific registers.

The standard 7-bit I²C slave address is 0x60 or 1100000. 8-bit read is 0xC1, 8-bit write is 0xC0.

Consult factory for alternate addresses. For further information and examples, please read application note AN4519 Sensor I²C Setup and FAQ.

7 Register Descriptions

Table 9. Register Address Map

| Register Address | Name | Reset | Reset when STBY to Active | Type | Auto-Increment Address | | Comment | |
|------------------|--|-------|---------------------------|------|------------------------|------|---|---|
| 0x00 | Sensor Status Register (STATUS) ⁽¹⁾⁽²⁾ | 0x00 | Yes | R | 0x01 | | Alias for DR_STATUS or F_STATUS | |
| 0x01 | Pressure Data Out MSB (OUT_P_MSB) ⁽¹⁾⁽²⁾ | 0x00 | Yes | R | 0x02 | 0x01 | Bits 12-19 of 20-bit real-time Pressure sample. | Root pointer to Pressure and Temperature FIFO data. |
| 0x02 | Pressure Data Out CSB (OUT_P_CSB) ⁽¹⁾⁽²⁾ | 0x00 | Yes | R | 0x03 | | Bits 4-11 of 20-bit real-time Pressure sample | |
| 0x03 | Pressure Data Out LSB (OUT_P_LSB) ⁽¹⁾⁽²⁾ | 0x00 | Yes | R | 0x04 | | Bits 0-3 of 20-bit real-time Pressure sample | |
| 0x04 | Temperature Data Out MSB (OUT_T_MSB) ⁽¹⁾⁽²⁾ | 0x00 | Yes | R | 0x05 | | Bits 4-11 of 12-bit real-time Temperature sample | |
| 0x05 | Temperature Data Out LSB (OUT_T_LSB) ⁽¹⁾⁽²⁾ | 0x00 | Yes | R | 0x00 | | Bits 1-3 of 12-bit real-time Temperature sample | |
| 0x06/0x00 | Sensor Status Register (DR_STATUS) ⁽¹⁾⁽²⁾ | 0x00 | Yes | R | 0x07 | | Data Ready status information | |
| 0x07 | Pressure Data Out Delta MSB (OUT_P_DELTA_MSB) ⁽¹⁾⁽²⁾ | 0x00 | Yes | R | 0x08 | | Bits 12-19 of 20-bit Pressure change data | |
| 0x08 | Pressure Data Out Delta CSB (OUT_P_DELTA_CSB) ⁽¹⁾⁽²⁾ | 0x00 | Yes | R | 0x09 | | Bits 4-11 of 20-bit Pressure change data | |
| 0x09 | Pressure Data Out Delta LSB (OUT_P_DELTA_LSB) ⁽¹⁾⁽²⁾ | 0x00 | Yes | R | 0x0A | | Bits 0-3 of 20-bit Pressure change data | |
| 0x0A | Temperature Data Out Delta MSB (OUT_T_DELTA_MSB) ⁽¹⁾⁽²⁾ | 0x00 | Yes | R | 0x0B | | Bits 4-11 of 12-bit Temperature change data | |
| 0x0B | Temperature Data Out Delta LSB (OUT_T_DELTA_LSB) ⁽¹⁾⁽²⁾ | 0x00 | Yes | R | 0x06 | | Bits 0-3 of 12-bit Temperature change data | |
| 0x0C | Device Identification Register (WHO_AM_I) | 0xC4 | No | R | 0x0D | | Fixed Device ID Number | |
| 0x0D | FIFO Status Register (F_STATUS) ⁽¹⁾⁽²⁾ | 0x00 | Yes | R | 0x0E | | FIFO Status: No FIFO event detected | |
| 0x0E/0x01 | FIFO 8-bit Data Access (F_DATA) ⁽¹⁾⁽²⁾ | 0x00 | Yes | R | 0x0E | | FIFO 8-bit data access | |
| 0x0F | FIFO Setup Register (F_SETUP) ⁽¹⁾⁽³⁾ | 0x00 | No | R/W | 0x10 | | FIFO setup | |
| 0x10 | Time Delay Register (TIME_DLY) ⁽¹⁾⁽²⁾ | 0x00 | Yes | R | 0x11 | | Time since FIFO overflow | |
| 0x11 | System Mode Register (SYSMOD) ⁽²⁾ | 0x00 | Yes | R | 0x12 | | Current system mode | |
| 0x12 | Interrupt Source Register (INT_SOURCE) ⁽¹⁾ | 0x00 | No | R | 0x13 | | Interrupt status | |
| 0x13 | PT Data Configuration Register (PT_DATA_CFG) ⁽¹⁾⁽³⁾ | 0x00 | No | R/W | 0x14 | | Data event flag configuration | |
| 0x14 | BAR Input in MSB (BAR_IN_MSB) ⁽¹⁾⁽³⁾ | 0xC5 | No | R/W | 0x15 | | Barometric input for Altitude calculation bits 8-15 | |
| 0x15 | BAR Input in LSB (BAR_IN_LSB) ⁽¹⁾⁽³⁾ | 0xE7 | No | R/W | 0x16 | | Barometric input for Altitude calculation bits 0-7 | |

Table 9. Register Address Map

| | | | | | | |
|------|--|------|----|-----|------|--|
| 0x16 | Pressure Target MSB (P_TGT_MSB) ⁽¹⁾⁽³⁾ | 0x00 | No | R/W | 0x17 | Pressure/Altitude target value bits 8-15 |
| 0x17 | Pressure Target LSB (P_TGT_LSB) ⁽¹⁾⁽³⁾ | 0x00 | No | R/W | 0x18 | Pressure/Altitude target value bits 0-7 |
| 0x18 | Temperature Target (T_TGT) ⁽¹⁾⁽³⁾ | 0x00 | No | R/W | 0x19 | Temperature target value |
| 0x19 | Pressure/Altitude Window MSB (P_WND_MSB) ⁽¹⁾⁽³⁾ | 0x00 | No | R/W | 0x1A | Pressure/Altitude window value bits 8-15 |
| 0x1A | Pressure/Altitude Window LSB (P_WND_LSB) ⁽¹⁾⁽³⁾ | 0x00 | No | R/W | 0x1B | Pressure/Altitude window value bits 0-7 |
| 0x1B | Temperature Window (T_WND) ⁽¹⁾⁽³⁾ | 0x00 | No | R/W | 0x1C | Temperature window value |
| 0x1C | Minimum Pressure Data Out MSB (P_MIN_MSB) ⁽¹⁾⁽³⁾ | 0x00 | No | R/W | 0x1D | Minimum Pressure/Altitude bits 12-19 |
| 0x1D | Minimum Pressure Data Out CSB (P_MIN_CSB) ⁽¹⁾⁽³⁾ | 0x00 | No | R/W | 0x1E | Minimum Pressure/Altitude bits 4-11 |
| 0x1E | Minimum Pressure Data Out LSB (P_MIN_LSB) ⁽¹⁾⁽³⁾ | 0x00 | No | R/W | 0x1F | Minimum Pressure/Altitude bits 0-3 |
| 0x1F | Minimum Temperature Data Out MSB (T_MIN_MSB) ⁽¹⁾⁽³⁾ | 0x00 | No | R/W | 0x20 | Minimum Temperature bits 8-15 |
| 0x20 | Minimum Temperature Data Out LSB (T_MIN_LSB) ⁽¹⁾⁽³⁾ | 0x00 | No | R/W | 0x21 | Minimum Temperature bits 0-7 |
| 0x21 | Maximum Pressure Data Out MSB (P_MAX_MSB) ⁽¹⁾⁽³⁾ | 0x00 | No | R/W | 0x22 | Maximum Pressure/Altitude bits 12-19 |
| 0x22 | Maximum Pressure Data Out CSB (P_MAX_CSB) ⁽¹⁾⁽³⁾ | 0x00 | No | R/W | 0x23 | Maximum Pressure/Altitude bits 4-11 |
| 0x23 | Maximum Pressure Data Out LSB (P_MAX_LSB) ⁽¹⁾⁽³⁾ | 0x00 | No | R/W | 0x24 | Maximum Pressure/Altitude bits 0-3 |
| 0x24 | Maximum Temperature Data Out MSB (T_MAX_MSB) ⁽¹⁾⁽³⁾ | 0x00 | No | R/W | 0x25 | Maximum Temperature bits 8-15 |
| 0x25 | Maximum Temperature Data Out LSB (T_MAX_LSB) ⁽¹⁾⁽³⁾ | 0x00 | No | R/W | 0x26 | Maximum Temperature bits 0-7 |
| 0x26 | Control Register 1 (CTRL_REG1) ⁽¹⁾⁽⁴⁾ | 0x00 | No | R/W | 0x27 | Modes, Oversampling |
| 0x27 | Control Register 2 (CTRL_REG2) ⁽¹⁾⁽⁴⁾ | 0x00 | No | R/W | 0x28 | Acquisition time step |
| 0x28 | Control Register 3 (CTRL_REG3) ⁽¹⁾⁽⁴⁾ | 0x00 | No | R/W | 0x29 | Interrupt pin configuration |
| 0x29 | Control Register 4 (CTRL_REG4) ⁽¹⁾⁽⁴⁾ | 0x00 | No | R/W | 0x2A | Interrupt enables |
| 0x2A | Control Register 5 (CTRL_REG5) ⁽¹⁾⁽⁴⁾ | 0x00 | No | R/W | 0x2B | Interrupt output pin assignment |
| 0x2B | Pressure Data User Offset Register (OFF_P) | 0x00 | No | R/W | 0x2C | Pressure data offset |
| 0x2C | Temperature Data User Offset Register (OFF_T) | 0x00 | No | R/W | 0x2D | Temperature data offset |
| 0x2D | Altitude Data User Offset Register (OFF_H) | 0x00 | No | R/W | 0x0C | Altitude data offset |

1. Register contents are preserved when transitioning from "ACTIVE" to "STANDBY" mode.
2. Register contents are reset when transitioning from "STANDBY" to "ACTIVE" mode.
3. Register contents can be modified anytime in "STANDBY" or "ACTIVE" mode.
4. Modification of this register's contents can only occur when device in "STANDBY" mode except the SBYB, OST and RST bit fields in CTRL_REG1 register.

Table 10. Register Address Map with FIFO Modes⁽¹⁾

| Register Address | Name | Reset Value | Reset when STANDBY to ACTIVE | Type | Auto-Increment Address | | Comment | |
|---|---|-------------|------------------------------|------|------------------------|------|--|---|
| Registers: Area A (F_Mode = 0, FIFO disabled) | | | | | | | | |
| 0x00/0x06 | Sensor Status Register (DR_STATUS) | 0x00 | Yes | R | 0x01 | | DR_STATUS | |
| 0x01 | Pressure Data Out MSB (OUT_P_MSB) | 0x00 | Yes | R | 0x02 | 0x01 | Bits 12-19 of 20-bit real-time Pressure sample. | Root pointer to Pressure and Temperature FIFO data. |
| 0x02 | Pressure Data Out CSB (OUT_P_CSB) | 0x00 | Yes | R | 0x03 | | Bits 4-11 of 20-bit real-time Pressure sample | |
| 0x03 | Pressure Data Out LSB (OUT_P_LSB) | 0x00 | Yes | R | 0x04 | | Bits 0-3 of 20-bit real-time Pressure sample | |
| 0x04 | Temperature Data Out MSB (OUT_T_MSB) | 0x00 | Yes | R | 0x05 | | Bits 4-11 of 12-bit real-time Temperature sample | |
| 0x05 | Temperature Data Out LSB (OUT_T_LSB) | 0x00 | Yes | R | 0x00 | | Bits 0-3 of 12-bit real-time Temperature sample | |
| Registers: Area A (F_Mode > 0, FIFO in circular buffer or full stop mode) | | | | | | | | |
| 0x00/0x0D | Sensor Status Register (F_STATUS) | 0x00 | Yes | R | 0x01 | | F_STATUS | |
| 0x01 | FIFO 8-bit Data Access (F_DATA) | 0x00 | Yes | R | 0x01 | | 0x01 | |
| 0x02 | Read to Reserved Area returns 00 | 0x00 | N/A | — | 0x03 | | — | |
| 0x03 | Read to Reserved Area returns 00 | 0x00 | N/A | — | 0x04 | | — | |
| 0x04 | Read to Reserved Area returns 00 | 0x00 | N/A | — | 0x05 | | — | |
| 0x05 | Read to Reserved Area returns 00 | 0x00 | N/A | — | 0x00 | | — | |

1. The Registers in Area A from 0x00 to 0x05 depend on the F_MODE bit setting in FIFO Setup Register (F_SETUP).

F_MODE = 00, FIFO is disabled.

F_MODE = 01 is circular buffer.

F_MODE = 10 is full stop mode.

7.1 Sensor Status

7.1.1 Status (0x00)

Table 11. Alias for DR_Status (0x06) or F_Status (0x0D)

| FIFO Data Enabled Mode Bit Setting | |
|------------------------------------|-------------------------|
| F_MODE = 00 ⁽¹⁾ | 0x00 = DR_STATUS (0x06) |
| F_MODE > 00 | 0x00 = F_STATUS (0x0D) |

1. The F_MODE is defined in Section 7.3.3

The aliases allow the STATUS register to be read easily before reading the current Pressure/Altitude or Temperature data, delta Pressure/Altitude or Temperature data or FIFO data using register address auto-incrementing mechanism.

7.1.2 DR_STATUS (0x06)

The STATUS register provides the acquisition status information on a per sample basis, and reflects real-time updates to the OUT_P and OUT_T registers. The same STATUS register can be read through an alternate address.

7.1.2.1 Data Registers with F_MODE = 00 (FIFO Disabled)

When the FIFO subsystem data output register driver is disabled (F_MODE = 00), the register indicates the real-time status information of the sample data.

Table 12. DR_STATUS Register

| | | | | | | | | |
|-------|------|-----|-----|---|------|-----|-----|---|
| | 7 | 6 | 5 | 4 | 3 | 2 | 1 | 0 |
| R | PTOW | POW | TOW | 0 | PTDR | PDR | TDR | 0 |
| W | | | | | | | | |
| Reset | 0 | 0 | 0 | 0 | 0 | 0 | 0 | 0 |

Table 13. DR_STATUS Bit Descriptions

| Name | Description |
|------|---|
| PTOW | Pressure/Altitude OR Temperature data overwrite. PTOW is set to 1 whenever new data is acquired before completing the retrieval of the previous set. This event occurs when the content of at least one data register (i.e. OUT_P, OUT_T) has been overwritten. PTOW is cleared when the high-bytes of the data (OUT_P_MSB or OUT_T_MSB) are read, when F_MODE is zero. PTOW is cleared by reading F_DATA register when F_MODE > 0. Default value: 0 0: No data overwrite has occurred 1: Previous Pressure/Altitude or Temperature data was overwritten by new Pressure/Altitude or Temperature data before it was read |
| POW | Pressure/Altitude data overwrite. POW is set to 1 whenever a new Pressure/Altitude acquisition is completed before the retrieval of the previous data. When this occurs the previous data is overwritten. POW is cleared anytime OUT_P_MSB register is read, when F_MODE is zero. POW is cleared by reading F_DATA register when F_MODE > 0. Default value: 0 0: No data overwrite has occurred 1: Previous Pressure/Altitude data was overwritten by new Pressure/Altitude data before it was read |
| TOW | Temperature data overwrite. TOW is set to 1 whenever a new Temperature acquisition is completed before the retrieval of the previous data. When this occurs the previous data is overwritten. TOW is cleared anytime OUT_T_MSB register is read, when F_MODE is zero. TOW is cleared by reading F_DATA register when F_MODE > 0. Default value: 0 0: No data overwrite has occurred 1: Previous Temperature data was overwritten by new Temperature data before it was read |
| PTDR | Pressure/Altitude OR Temperature data ready. PTDR signals that a new acquisition for either Pressure/Altitude or Temperature is available. PTDR is cleared anytime OUT_P_MSB or OUT_T_MSB register is read, when F_MODE is zero. PTDR is cleared by reading F_DATA register when F_MODE > 0. Default value: 0 0: No new set of data ready 1: A new set of data is ready |
| PDR | Pressure/Altitude new data available. PDR is set to 1 whenever a new Pressure/Altitude data acquisition is completed. PDR is cleared anytime OUT_P_MSB register is read, when F_MODE is zero. PDR is cleared by reading F_DATA register when F_MODE > 0. 0: No new Pressure/Altitude data is available 1: A new set of Pressure/Altitude data is ready |
| TDR | Temperature new Data Available. TDR is set to 1 whenever a Temperature data acquisition is completed. TDR is cleared anytime OUT_T_MSB register is read, when F_MODE is zero. TDR is cleared by reading F_DATA register when F_MODE > 0. 0: No new Temperature data ready 1: A new Temperature data is ready |

PDR and **POW** flag generation is required for the Pressure/Altitude event flag generator to be enabled (PDEFE = 1) in the PT Data Configuration Register (PT_DATA_CFG).

TDR and **TOW** flag generation is required for the Temperature event flag generator to be enabled (TDEFE = 1) in the PT Data Configuration Register (PT_DATA_CFG).

PTDR and **PTOW** flag generation requires the DREM event flag generator to be enabled in the PT Data Configuration Register (PT_DATA_CFG).

7.1.3 OUT_P_MSB (0x01), OUT_P_CSB (0x02), OUT_P_LSB (0x03), OUT_T_MSB (0x04), OUT_T_LSB (0x05)

The Altitude data is arranged as 20-bit 2's complement value in meters. The data is stored as meters with the 16 bits of OUT_P_MSB and OUT_P_CSB and with fractions of a meter stored in bits 7-4 of OUT_P_LSB. Be aware that the fractional bits are not signed, therefore, they are not represented in 2's complement.

The Pressure data is arranged as 20-bit unsigned data in Pascals. The first 18 bits are located in OUT_P_MSB, OUT_P_CSB and bits 7-6 of OUT_P_LSB. The 2 bits in position 5-4 of OUT_P_LSB represent the fractional component.

When RAW bit is set (CTRL_REG1), then the RAW value is stored in all 24 bits of OUT_P_MSB, OUT_P_CSB and OUT_P_LSB.

The Temperature data is arranged as 12-bit 2's complement value in degrees C. The 8 bits of OUT_T_MSB representing degrees and with fractions of a degree are stored in 4 bits in position 7-4 of OUT_T_LSB. Be aware that the fractional bits are not signed, therefore, they are not represented in 2's complement. When RAW is selected then the RAW value is stored in all 16 bits of OUT_T_MSB and OUT_T_LSB.

The sample data output registers store the current sample data if the FIFO data output register driver is disabled, but if the FIFO data output register driver is enabled, the sample data output registers point to the head of the FIFO buffer which contains the previous Pressure/Altitude and Temperature data samples.

7.1.3.1 Data Registers with F_MODE = 00

The DR_STATUS register, OUT_P_MSB, OUT_P_CSB, OUT_P_LSB, OUT_T_MSB, and OUT_T_LSB are stored in the auto-incrementing address range of 0x00 to 0x05. This allows the host controller to read the status register followed by the 20-bit Pressure/Altitude and 12-bit Temperature in a 6 byte I²C transaction.

Table 14. OUT_P_MSB Register

| | | | | | | | | |
|-------|------|------|------|------|------|------|------|------|
| | 7 | 6 | 5 | 4 | 3 | 2 | 1 | 0 |
| R | PD19 | PD18 | PD17 | PD16 | PD15 | PD14 | PD13 | PD12 |
| W | | | | | | | | |
| Reset | 0 | 0 | 0 | 0 | 0 | 0 | 0 | 0 |

Table 15. OUT_P_CSB Register

| | | | | | | | | |
|-------|------|------|-----|-----|-----|-----|-----|-----|
| | 7 | 6 | 5 | 4 | 3 | 2 | 1 | 0 |
| R | PD11 | PD10 | PD9 | PD8 | PD7 | PD6 | PD5 | PD4 |
| W | | | | | | | | |
| Reset | 0 | 0 | 0 | 0 | 0 | 0 | 0 | 0 |

Table 16. OUT_P_LSB Register

| | | | | | | | | |
|-------|-----|-----|-----|-----|---|---|---|---|
| | 7 | 6 | 5 | 4 | 3 | 2 | 1 | 0 |
| R | PD3 | PD2 | PD1 | PD0 | 0 | 0 | 0 | 0 |
| W | | | | | | | | |
| Reset | 0 | 0 | 0 | 0 | 0 | 0 | 0 | 0 |

Table 17. OUT_T_MSB Register

| | | | | | | | | |
|-------|------|------|-----|-----|-----|-----|-----|-----|
| | 7 | 6 | 5 | 4 | 3 | 2 | 1 | 0 |
| R | TD11 | TD10 | TD9 | TD8 | TD7 | TD6 | TD5 | TD4 |
| W | | | | | | | | |
| Reset | 0 | 0 | 0 | 0 | 0 | 0 | 0 | 0 |

Table 18. OUT_T_LSB Register

| | | | | | | | | |
|-------|-----|-----|-----|-----|---|---|---|---|
| | 7 | 6 | 5 | 4 | 3 | 2 | 1 | 0 |
| R | TD3 | TD2 | TD1 | TD0 | 0 | 0 | 0 | 0 |
| W | | | | | | | | |
| Reset | 0 | 0 | 0 | 0 | 0 | 0 | 0 | 0 |

If the FIFO data output register driver is enabled (F_MODE > 00), register 0x01 points to the FIFO read pointer, while registers 0x02, 0x03, 0x04, 0x05, return a value of zero when read.

7.1.4 OUT_P_DELTA_MSB (0x07), OUT_P_DELTA_CSB (0x08), OUT_P_DELTA_LSB (0x09), OUT_T_DELTA_MSB (0x0A), OUT_T_DELTA_LSB (0x0B)

Differences from last Pressure/Altitude and Temperature samples.

The Altitude data is arranged as 20-bit 2's complement value in meters. Stored as meters with the 16 bits of OUT_P_DELTA_MSB and OUT_P_DELTA_CSB and with fractions of a meter stored in 4 bits in position 7-4 of OUT_P_DELTA_LSB.

The Pressure is arranged as 20-bit 2's complement value in Pascals. The first 18 bits are located in OUT_P_DELTA_MSB, OUT_P_DELTA_CSB and bits 7-6 of OUT_P_DELTA_LSB. The 2 bits in position 5-4 of OUT_P_DELTA_LSB represent the fractional component.

The Temperature data is arranged as 12-bit values in degrees C. The 8 bits of OUT_T_DELTA_MSB representing degrees and with fractions of a degree stored in 4 bits in position 7-4 of OUT_T_DELTA_LSB.

In RAW mode, these registers are not used and their values are not updated.

Note: The OUT_P_DELTA, OUT_T_DELTA registers store the difference data information regardless of the state of the FIFO data output register driver bit, F_MODE > 00.

Table 19. OUT_P_DELTA_MSB Register

| | | | | | | | | |
|-------|-------|-------|-------|-------|-------|-------|-------|-------|
| | 7 | 6 | 5 | 4 | 3 | 2 | 1 | 0 |
| R | PDD19 | PDD18 | PDD17 | PDD16 | PDD15 | PDD14 | PDD13 | PDD12 |
| W | | | | | | | | |
| Reset | 0 | 0 | 0 | 0 | 0 | 0 | 0 | 0 |

Table 20. OUT_P_DELTA_CSB Register

| | | | | | | | | |
|-------|-------|-------|------|------|------|------|------|------|
| | 7 | 6 | 5 | 4 | 3 | 2 | 1 | 0 |
| R | PDD11 | PDD10 | PDD9 | PDD8 | PDD7 | PDD6 | PDD5 | PDD4 |
| W | | | | | | | | |
| Reset | 0 | 0 | 0 | 0 | 0 | 0 | 0 | 0 |

Table 21. OUT_P_DELTA_LSB Register

| | | | | | | | | |
|-------|------|------|------|------|---|---|---|---|
| | 7 | 6 | 5 | 4 | 3 | 2 | 1 | 0 |
| R | TDD3 | TDD2 | TDD1 | TDD0 | 0 | 0 | 0 | 0 |
| W | | | | | | | | |
| Reset | 0 | 0 | 0 | 0 | 0 | 0 | 0 | 0 |

Table 22. OUT_T_DELTA_MSB Register

| | | | | | | | | |
|-------|-------|-------|------|------|------|------|------|------|
| | 7 | 6 | 5 | 4 | 3 | 2 | 1 | 0 |
| R | TDD11 | TDD10 | TDD9 | TDD8 | TDD7 | TDD6 | TDD5 | TDD4 |
| W | | | | | | | | |
| Reset | 0 | 0 | 0 | 0 | 0 | 0 | 0 | 0 |

Table 23. OUT_T_DELTA_LSB Register

| | | | | | | | | |
|-------|------|------|------|------|---|---|---|---|
| | 7 | 6 | 5 | 4 | 3 | 2 | 1 | 0 |
| R | TDD3 | TDD2 | TDD1 | TDD0 | 0 | 0 | 0 | 0 |
| W | | | | | | | | |
| Reset | 0 | 0 | 0 | 0 | 0 | 0 | 0 | 0 |

7.2 Device ID

7.2.1 WHO_AM_I (0x0C)

Device identification register. This register contains the device identifier which is set to 0xC4 by default. The value is factory programmed. Consult factory for custom alternate values.

Table 24. WHO_AM_I Register

| | | | | | | | | |
|-------|------------|------------|------------|------------|------------|------------|------------|------------|
| | 7 | 6 | 5 | 4 | 3 | 2 | 1 | 0 |
| R | | | | | | | | |
| W | | | | | | | | |
| Reset | (NVM data) | (NVM data) | (NVM data) | (NVM data) | (NVM data) | (NVM data) | (NVM data) | (NVM data) |
| | 1 | 1 | 0 | 0 | 0 | 1 | 0 | 0 |

7.3 FIFO Setup

7.3.1 F_STATUS (0x0D)

If the FIFO subsystem data output register driver is enabled, the status register indicates the current status information of the FIFO subsystem.

Table 25. F_STATUS

| | | | | | | | | |
|-------|-------|-------------|--------|--------|--------|--------|--------|--------|
| | 7 | 6 | 5 | 4 | 3 | 2 | 1 | 0 |
| R | F_OVF | F_WMRK_FLAG | F_CNT5 | F_CNT4 | F_CNT3 | F_CNT2 | F_CNT1 | F_CNT0 |
| W | | | | | | | | |
| Reset | 0 | 0 | 0 | 0 | 0 | 0 | 0 | 0 |

Table 26. FIFO Flag Event Descriptions

| F_OVF | F_WMRK_FLAG | Event Description |
|-------|-------------|--|
| 0 | — | No FIFO overflow events detected. |
| 1 | — | FIFO overflow event detected. |
| — | 0 | No FIFO watermark events detected. |
| — | 1 | FIFO watermark event detected. FIFO sample count greater than watermark value. |

The F_OVF and F_WMRK_FLAG flags remain asserted while the event source is still active, but the user can clear the FIFO interrupt bit flag in the interrupt source register (INT_SOURCE) by reading the F_STATUS register. Therefore the F_OVF bit flag will remain asserted while the FIFO has overflowed and the F_WMRK_FLAG bit flag will remain asserted while the F_CNT value is greater than then F_WMRK value.

Table 27. FIFO Sample Count Bit Descriptions

| Name | Description |
|------------|---|
| F_CNT[5:0] | FIFO sample counter. F_CNT[5:0] bits indicate the number of samples currently stored in the FIFO buffer. Count 000000 indicates that the FIFO is empty. Default value: 00_0000. (000001 to 100000 indicates 1 to 32 samples stored in FIFO) |

7.3.2 F_DATA (0x0E)

F_DATA is a read only address which provides access to 8-bit FIFO data. FIFO holds a maximum of 32 samples; a maximum of $5 \times 32 = 160$ data bytes of samples can be read. When F_MODE bit in FIFO SETUP (F_SETUP) register is set to logic "1", the F_DATA pointer shares the same address location as OUT_P_MSB (0x01); therefore all accesses of the FIFO buffer data use the I²C address 0x01. Reads from the other data registers (0x02, 0x03, 0x04, 0x05) will return a value of 0x00. **Note:** The FIFO will **NOT** suspend to data accumulation during read transactions to F_DATA.

Table 28. F_DATA 8-bit Data Access Register

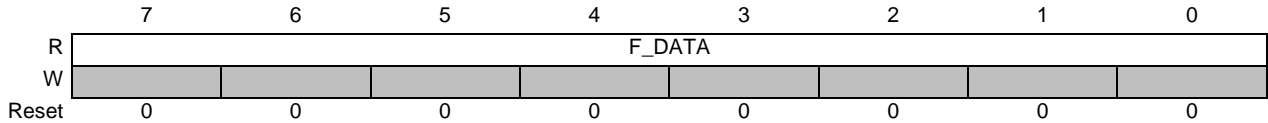

Table 29. Read Accesses through F_DATA

| | |
|----------------------|--------------------|
| 1 st read | OUT_P_MSB (oldest) |
| 2 nd read | OUT_P_CSB (oldest) |
| 3 rd read | OUT_P_LSB (oldest) |
| 4 th read | OUT_T_MSB (oldest) |
| 5 th read | OUT_T_LSB (oldest) |
| ⋮ | ⋮ |
| | OUT_T_LSB (oldest) |
| | 0x00 |
| | 0x00 |

7.3.3 F_SETUP (0x0F)

A FIFO sample count exceeding the watermark event does not stop the FIFO from accepting new data.

The FIFO update rate is dictated by the selected system acquisition rate (ST bits of CTRL_REG2).

When a byte is read from the FIFO buffer the oldest sample data in the FIFO buffer is returned and also deleted from the front of the FIFO buffer, while the FIFO sample count is decremented by one. It is assumed that the host application shall use the I²C BURST read transaction to dump the FIFO.

Table 30. F_SETUP Register

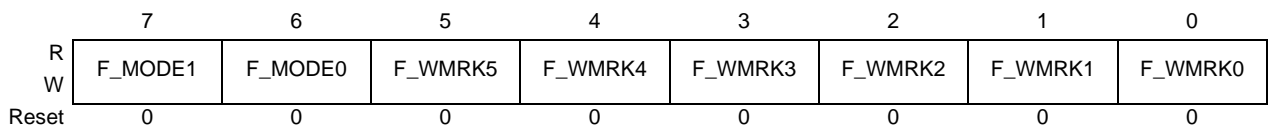

Table 31. F_SETUP Bit Descriptions

| Name | Description |
|----------------------------------|--|
| F_MODE[1:0] ⁽¹⁾⁽²⁾⁽³⁾ | <p>FIFO buffer overflow mode. Default value: 0 00: FIFO is disabled 01: FIFO contains the most recent samples when overflowed (circular buffer). Oldest sample is discarded to be replaced by new sample 10: FIFO stops accepting new samples when overflowed 11: Not Used</p> <p>The FIFO is flushed whenever the FIFO is disabled, or transitioning from "STANDBY" mode to "ACTIVE" mode. Disabling the FIFO (F_MODE = 00) resets the F_OVF, F_WMRK_FLAG, F_CNT to zero. A FIFO overflow event (i.e. F_CNT = 32) will assert the F_OVF flag and a FIFO sample count equal to the sample count watermark (i.e. F_WMRK) asserts the F_WMRK_FLAG event flag. To switch between FIFO modes, first disable the FIFO and then write the new value to F_MODE.</p> |

Table 31. F_SETUP Bit Descriptions

| | |
|----------------------------|--|
| F_WMRK[5:0] ⁽²⁾ | FIFO Event Sample Count Watermark. Default value: 00_0000. These bits set the number of FIFO samples required to trigger a watermark interrupt. A FIFO watermark event flag (F_WMRK_FLAG) is raised when FIFO sample count F_CNT[5:0] value is equal to the F_WMRK[5:0] watermark. Setting the F_WMRK[5:0] to 00_0000 will disable the FIFO watermark event flag generation. |
|----------------------------|--|

1. This bit field can be written in ACTIVE mode.
2. This bit field can be written in STANDBY mode.
3. The FIFO mode (F_MODE) cannot be switched between the two operational modes (01 & 10).

7.4 Time Delay Register

7.4.1 TIME_DLY(0x10)

The time delay register contains the number of ticks of data sample time since the last byte of the FIFO was written. This register starts to increment on FIFO overflow or data wrap and clears when last byte of FIFO is read.

Table 32. Time Delay Register

| | | | | | | | | |
|-------|-----|-----|-----|-----|-----|-----|-----|-----|
| | 7 | 6 | 5 | 4 | 3 | 2 | 1 | 0 |
| R | TD7 | TD6 | TD5 | TD4 | TD3 | TD2 | TD1 | TD0 |
| W | | | | | | | | |
| Reset | 0 | 0 | 0 | 0 | 0 | 0 | 0 | 0 |

7.5 System Mode Register

7.5.1 SYSMOD (0x11)

The system mode register indicates the current device operating mode.

Table 33. SYSMOD Register

| | | | | | | | | |
|-------|---|---|---|---|---|---|---|--------|
| | 7 | 6 | 5 | 4 | 3 | 2 | 1 | 0 |
| R | 0 | | 0 | 0 | 0 | 0 | 0 | SYSMOD |
| W | | | | | | | | |
| Reset | 0 | 0 | 0 | 0 | 0 | 0 | 0 | 0 |

Table 34. SYSMOD Bit Descriptions

| Name | Description |
|----------|---|
| RESERVED | Reserved Bits 7-1, will always read 0. |
| SYSMOD | System mode. Default value: 0. 0: STANDBY mode 1: ACTIVE mode |

7.6 System Interrupt Status

7.6.1 INT_SOURCE (0x12)

Interrupt source register. The bits that are set (logic '1') indicate which function has asserted its interrupt and conversely, bits that are cleared (logic '0') indicate which function has not asserted its interrupt.

The setting of the bits is rising edge sensitive, the bit is set by a low to high state change and reset by reading the appropriate source register.

Table 35. INT_SOURCE Register

| | | | | | | | | |
|-------|----------|----------|--------|--------|---------|---------|----------|----------|
| | 7 | 6 | 5 | 4 | 3 | 2 | 1 | 0 |
| R | SRC_DRDY | SRC_FIFO | SRC_PW | SRC_TW | SRC_PTH | SRC_TTH | SRC_PCHG | SRC_TCHG |
| W | | | | | | | | |
| Reset | 0 | 0 | 0 | 0 | 0 | 0 | 0 | 0 |

Table 36. INT_SOURCE Bit Descriptions

| Name | Description |
|----------|---|
| SRC_DRDY | Data ready interrupt status bit. Logic '1' indicates that Pressure/Altitude or Temperature data ready interrupt is active indicating the presence of new data and/or a data overwrite, otherwise it is a logic '0'. This bit is asserted when the PTOW and/or PTDR is set and the functional block interrupt has been enabled. This bit is cleared by reading the STATUS and Pressure/Temperature register. |
| SRC_FIFO | FIFO interrupt status bit. Logic '1' indicates that a FIFO interrupt event such as an overflow event has occurred. Logic '0' indicates that no FIFO interrupt event has occurred. This bit is cleared by reading the F_STATUS register. FIFO interrupt event generators: FIFO Overflow, or (Watermark: F_CNT = F_WMRK). |
| SRC_PW | Altitude/Pressure alerter status bit near or equal to target Pressure/Altitude (near is within target value ± window value). Window value needs to be non zero for interrupt to trigger. |
| SRC_TW | Temperature alerter status bit near or equal to target temperature (near is within target value ± window value.) Window value needs to be non zero for interrupt to trigger. |
| SRC_PTH | Altitude/Pressure threshold interrupt. With the window set to a non zero value, the trigger will occur on crossing any of the thresholds: upper, center or lower. If the window is set to 0, it will only trigger on crossing the center threshold. |
| SRC_TTH | Temperature threshold interrupt. With the window set to a non zero value, the trigger will occur on crossing any of the thresholds: upper, center or lower. If the window is set to 0, it will only trigger on crossing the center threshold. |
| SRC_PCHG | Delta P interrupt status bit. |
| SRC_TCHG | Delta T interrupt status bit |

7.7 Sensor Data

7.7.1 PT_DATA_CFG (0x13)

The PT_DATA_CFG register configures the Pressure data, Temperature data and event flag generator.

Table 37. PT_DATA_CFG Register

| | | | | | | | | |
|-------|---|---|---|---|---|------|-------|-------|
| | 7 | 6 | 5 | 4 | 3 | 2 | 1 | 0 |
| R | 0 | 0 | 0 | 0 | 0 | DREM | PDEFE | TDEFE |
| W | | | | | | | | |
| Reset | 0 | 0 | 0 | 0 | 0 | 0 | 0 | 0 |

Table 38. PT_DATA_CFG Bit Descriptions

| Name | Description |
|-------|---|
| DREM | Data ready event mode. If the DREM bit is set logic '1' and one or more of the data ready event flags (PDEFE, TDEFE) are enabled, then an event flag will be raised upon change in state of the data. If the DREM bit is cleared logic '0' and one or more of the data ready event flags are enabled, then an event flag will be raised whenever the system acquires a new set of data. Default value: 0. 0: Event detection disabled 1: Generate data ready event flag on new Pressure/Altitude or Temperature data |
| PDEFE | Data event flag enable on new Pressure/Altitude data. Default value: 0 0: Event detection disabled 1: Raise event flag on new Pressure/Altitude data |
| TDEFE | Data event flag enable on new Temperature data. Default value: 0 0: Event detection disabled 1: Raise event flag on new Temperature data |

7.8 Barometric Pressure Input

7.8.1 BAR_IN_MSB, BAR_IN_LSB (0x14, 0x15)

Barometric input for altitude calculations. Input is equivalent sea level pressure for measurement location.

Value is input in 2 Pa units.

Units are input as unsigned 16-bit integers. The default value is 101,326 Pa. The default value can be changed by writing to this register

Table 39. BAR_IN_MSB Register

| | | | | | | | | |
|-------|---------|---------|---------|---------|---------|---------|--------|--------|
| | 7 | 6 | 5 | 4 | 3 | 2 | 1 | 0 |
| R | BAR[15] | BAR[14] | BAR[13] | BAR[12] | BAR[11] | BAR[10] | BAR[9] | BAR[8] |
| W | | | | | | | | |
| Reset | 1 | 1 | 0 | 0 | 0 | 1 | 0 | 1 |

Table 40. BAR_IN_LSB Register

| | | | | | | | | |
|-------|--------|--------|--------|--------|--------|--------|--------|--------|
| | 7 | 6 | 5 | 4 | 3 | 2 | 1 | 0 |
| R | BAR[7] | BAR[6] | BAR[5] | BAR[4] | BAR[3] | BAR[2] | BAR[1] | BAR[0] |
| W | | | | | | | | |
| Reset | 1 | 1 | 1 | 0 | 0 | 1 | 1 | 1 |

7.9 Pressure/Altitude Target

7.9.1 P_TGT_MSB, P_TGT_LSB (0x16, 0x17)

Altitude/Pressure target value. This value works in conjunction with the window value (P_WND_MSB and P_WND_LSB).

In Altitude mode, the register value is 16-bit 2's complement value in meters.

In Pressure mode, the value is 16-bit unsigned value in 2 Pa units.

Table 41. P_TGT_MSB Register

| | | | | | | | | |
|-------|---------|---------|---------|---------|---------|---------|--------|--------|
| | 7 | 6 | 5 | 4 | 3 | 2 | 1 | 0 |
| R | P_TGT15 | P_TGT14 | P_TGT13 | P_TGT12 | P_TGT11 | P_TGT10 | P_TGT9 | P_TGT8 |
| W | | | | | | | | |
| Reset | 0 | 0 | 0 | 0 | 0 | 0 | 0 | 0 |

Table 42. P_TGT_LSB Register

| | | | | | | | | |
|-------|--------|--------|--------|--------|--------|--------|--------|--------|
| | 7 | 6 | 5 | 4 | 3 | 2 | 1 | 0 |
| R | P_TGT7 | P_TGT6 | P_TGT5 | P_TGT4 | P_TGT3 | P_TGT2 | P_TGT1 | P_TGT0 |
| W | | | | | | | | |
| Reset | 0 | 0 | 0 | 0 | 0 | 0 | 0 | 0 |

7.10 Temperature Target

7.10.1 T_TGT (0x18)

Temperature target value input in 2's complement value in °C.

Table 43. T_TGT Register

| | | | | | | | | |
|-------|--------|--------|--------|--------|--------|--------|--------|--------|
| | 7 | 6 | 5 | 4 | 3 | 2 | 1 | 0 |
| R | T_TGT7 | T_TGT6 | T_TGT5 | T_TGT4 | T_TGT3 | T_TGT2 | T_TGT1 | T_TGT0 |
| W | | | | | | | | |
| Reset | 0 | 0 | 0 | 0 | 0 | 0 | 0 | 0 |

7.11 Pressure/Altitude Window

7.11.1 P_WND_MSB, P_WND_LSB (0x19, 0x1A)

Pressure/Altitude window value. Unsigned 16-bit value of window value in meters or in 2 Pa units

Table 44. P_WND_LSB Register

| | | | | | | | | |
|-------|-------|-------|-------|-------|-------|-------|------|------|
| | 7 | 6 | 5 | 4 | 3 | 2 | 1 | 0 |
| R | P_W15 | P_W14 | P_W13 | P_W12 | P_W11 | P_W10 | P_W9 | P_W8 |
| W | | | | | | | | |
| Reset | 0 | 0 | 0 | 0 | 0 | 0 | 0 | 0 |

Table 45. P_WND_MSB Description

| | | | | | | | | |
|-------|------|------|------|------|------|------|------|------|
| | 7 | 6 | 5 | 4 | 3 | 2 | 1 | 0 |
| R | P_W7 | P_W6 | P_W5 | P_W4 | P_W3 | P_W2 | P_W1 | P_W0 |
| W | | | | | | | | |
| Reset | 0 | 0 | 0 | 0 | 0 | 0 | 0 | 0 |

7.12 Temperature Window

7.12.1 T_WND (0x1B)

Temperature alarm window value. Unsigned 8-bit value °C.

Table 46. T_WND Register

| | | | | | | | | |
|-------|------|------|------|------|------|------|------|------|
| | 7 | 6 | 5 | 4 | 3 | 2 | 1 | 0 |
| R | T_W7 | T_W6 | T_W5 | T_W4 | T_W3 | T_W2 | T_W1 | T_W0 |
| W | | | | | | | | |
| Reset | 0 | 0 | 0 | 0 | 0 | 0 | 0 | 0 |

7.13 Minimum Pressure

7.13.1 P_MIN_MSB, P_MIN_CSB, P_MIN_LSB (0x1C, 0x1D, 0x1E)

Register with captured minimum Pressure/Altitude value.

The Altitude data is arranged as 20-bit 2's complement value in meters. Stored as meters with the 16 bits of P_MIN_MSB and P_MIN_CSB and with fractions of a meter stored in 4 bits in position 7-4 of P_MIN_LSB.

The Pressure is arranged as 20-bit unsigned data in Pascals. The first 18 bits are located in P_MIN_MSB, P_MIN_CSB and bits 7-6 of P_MIN_LSB. The 2 bits in position 5-4 of P_MIN_LSB represent the fractional component.

The register is cleared on power-up or manually by writing '0' to the registers

Table 47. P_MIN_MSB Register

| | | | | | | | | |
|-------|----------|----------|----------|----------|----------|----------|----------|----------|
| | 7 | 6 | 5 | 4 | 3 | 2 | 1 | 0 |
| R | P_MIN 19 | P_MIN 18 | P_MIN 17 | P_MIN 16 | P_MIN 15 | P_MIN 14 | P_MIN 13 | P_MIN 12 |
| W | | | | | | | | |
| Reset | 0 | 0 | 0 | 0 | 0 | 0 | 0 | 0 |

Table 48. P_MIN_CSB Register

| | | | | | | | | |
|-------|----------|----------|---------|---------|---------|---------|---------|---------|
| | 7 | 6 | 5 | 4 | 3 | 2 | 1 | 0 |
| R | P_MIN 11 | P_MIN 10 | P_MIN 9 | P_MIN 8 | P_MIN 7 | P_MIN 6 | P_MIN 5 | P_MIN 4 |
| W | | | | | | | | |
| Reset | 0 | 0 | 0 | 0 | 0 | 0 | 0 | 0 |

Table 49. P_MIN_LSB Register

| | | | | | | | | |
|-------|---------|---------|---------|--------|---|---|---|---|
| | 7 | 6 | 5 | 4 | 3 | 2 | 1 | 0 |
| R | P_MIN 3 | P_MIN 2 | P_MIN 1 | P_MIN0 | 0 | 0 | 0 | 0 |
| W | | | | | | | | |
| Reset | 0 | 0 | 0 | 0 | 0 | 0 | 0 | 0 |

7.14 Maximum Pressure

7.14.1 P_MAX_MSB, P_MAX_CSB, P_MAX_LSB (0x21, 0x22, 0x23)

Register with captured maximum Pressure/Altitude value.

The Altitude data is arranged as 20-bit 2's complement value in meters. Stored as meters with the 16 bits of P_MAX_MSB and P_MAX_CSB and with fractions of a meter stored in 4 bits in position 7-4 of P_MAX_LSB.

The Pressure is arranged as 20-bit unsigned data in Pascals. The first 18 bits are located in P_MAX_MSB, P_MAX_CSB and bits 7-6 of P_MAX_LSB. The 2 bits in position 5-4 of P_MAX_LSB represent the fractional component.

The register is cleared on power-up or manually by writing '0' to the registers.

Table 50. P_MAX_MSB Register

| | | | | | | | | |
|-------|----------|----------|----------|----------|----------|----------|----------|----------|
| | 7 | 6 | 5 | 4 | 3 | 2 | 1 | 0 |
| R | P_MAX 19 | P_MAX 18 | P_MAX 17 | P_MAX 16 | P_MAX 15 | P_MAX 14 | P_MAX 13 | P_MAX 12 |
| W | | | | | | | | |
| Reset | 0 | 0 | 0 | 0 | 0 | 0 | 0 | 0 |

Table 51. P_MAX_CSB Register

| | | | | | | | | |
|-------|----------|----------|---------|---------|---------|---------|---------|---------|
| | 7 | 6 | 5 | 4 | 3 | 2 | 1 | 0 |
| R | P_MAX 11 | P_MAX 10 | P_MAX 9 | P_MAX 8 | P_MAX 7 | P_MAX 6 | P_MAX 5 | P_MAX 4 |
| W | | | | | | | | |
| Reset | 0 | 0 | 0 | 0 | 0 | 0 | 0 | 0 |

Table 52. P_MAX_LSB Register

| | | | | | | | | |
|-------|---------|---------|---------|---------|---|---|---|---|
| | 7 | 6 | 5 | 4 | 3 | 2 | 1 | 0 |
| R | P_MAX 3 | P_MAX 2 | P_MAX 1 | P_MAX 0 | 0 | 0 | 0 | 0 |
| W | | | | | | | | |
| Reset | 0 | 0 | 0 | 0 | 0 | 0 | 0 | 0 |

7.15 Minimum Temperature

7.15.1 T_MIN_MSB, T_MIN_LSB (0x1F, 0x20)

Register with captured minimum temperature value.

The Temperature data is arranged as 12-bit 2's complement value in degrees C. The 8 bits of T_MIN_MSB representing degrees and with fractions of a degree stored in 4 bits in position 7-4 of T_MIN_LSB.

The register is cleared on power-up or manually by writing '0' to the registers.

Table 53. T_MIN_MSB Register

| | | | | | | | | |
|-------|----------|----------|---------|---------|---------|---------|---------|---------|
| | 7 | 6 | 5 | 4 | 3 | 2 | 1 | 0 |
| R | T_MIN 11 | T_MIN 10 | T_MIN 9 | T_MIN 8 | T_MIN 7 | T_MIN 6 | T_MIN 5 | T_MIN 4 |
| W | | | | | | | | |
| Reset | 0 | 0 | 0 | 0 | 0 | 0 | 0 | 0 |

Table 54. T_MIN_LSB Register

| | | | | | | | | |
|-------|---------|---------|---------|---------|---|---|---|---|
| | 7 | 6 | 5 | 4 | 3 | 2 | 1 | 0 |
| R | T_MIN 3 | T_MIN 2 | T_MIN 1 | T_MIN 0 | 0 | 0 | 0 | 0 |
| W | | | | | | | | |
| Reset | 0 | 0 | 0 | 0 | 0 | 0 | 0 | 0 |

7.16 Maximum Temperature

7.16.1 T_MAX_MSB, T_MAX_LSB (0x24, 0x25)

Register with captured maximum temperature value.

The Temperature data is arranged as 12-bit 2's complement value in degrees C. The 8 bits of T_MAX_MSB representing degrees and with fractions of a degree stored in 4 bits in position 7-4 of T_MAX_LSB.

The register is cleared on power-up or manually by writing 0 to the registers

Table 55. T_MAX_MSB Register

| | | | | | | | | |
|-------|----------|----------|---------|---------|---------|---------|---------|---------|
| | 7 | 6 | 5 | 4 | 3 | 2 | 1 | 0 |
| R | T_MAX 11 | T_MAX 10 | T_MAX 9 | T_MAX 8 | T_MAX 7 | T_MAX 6 | T_MAX 5 | T_MAX 4 |
| W | | | | | | | | |
| Reset | 0 | 0 | 0 | 0 | 0 | 0 | 0 | 0 |

Table 56. T_MAX_LSB Register

| | | | | | | | | |
|-------|---------|---------|---------|---------|---|---|---|---|
| | 7 | 6 | 5 | 4 | 3 | 2 | 1 | 0 |
| R | T_MAX 3 | T_MAX 2 | T_MAX 1 | T_MAX 0 | 0 | 0 | 0 | 0 |
| W | | | | | | | | |
| Reset | 0 | 0 | 0 | 0 | 0 | 0 | 0 | 0 |

7.17 Control Registers

Note: Except for standby mode selection and OST (One Shot Mode), the device must be in STANDBY mode to change any of the fields within CTRL_REG1 (0x26).

7.17.1 CTRL_REG1 (0x26)

Table 57. CTRL_REG1 Register

| | | | | | | | | |
|-------|-----|-----|-----|-----|-----|-----|-----|------|
| | 7 | 6 | 5 | 4 | 3 | 2 | 1 | 0 |
| R | ALT | RAW | OS2 | OS1 | OS0 | 0 | OST | SBYB |
| W | | | | | | RST | | |
| Reset | 0 | 0 | 0 | 0 | 0 | 0 | 0 | 0 |

Table 58. CTRL_REG1 Bit Descriptions

| Name | Description |
|------|---|
| SBYB | This bit is sets the mode to ACTIVE, where the system will make measurements at periodic times based on the value of ST bits. Default value: 0 (STANDBY) 0: Part is in STANDBY mode 1: Part is ACTIVE |
| OST | OST bit will initiate a measurement immediately. If the SBYB bit is set to active, setting the OST bit will initiate an immediate measurement, the part will then return to acquiring data as per the setting of the ST bits in CTRL_REG2. In this mode, the OST bit does not clear itself and must be cleared and set again to initiate another immediate measurement. One Shot: When SBYB is 0, the OST bit is an auto-clear bit. When OST is set, the device initiates a measurement by going into active mode. Once a Pressure/Altitude and Temperature measurement is completed, it clears the OST bit and comes back to STANDBY mode. User shall read the value of the OST bit before writing to this bit again. |
| RST | Software Reset. This bit is used to activate the software reset. The Boot mechanism can be enabled in STANDBY and ACTIVE mode. When the Boot bit is enabled the boot mechanism resets all functional block registers and loads the respective internal registers with default values. If the system was already in STANDBY mode, the reboot process will immediately begin; else if the system was in ACTIVE mode, the boot mechanism will automatically transition the system from ACTIVE mode to STANDBY mode, only then can the reboot process begin. The I ² C communication system is reset to avoid accidental corrupted data access. At the end of the boot process the RST bit is de-asserted to 0. Reading this bit will return a value of zero. Default value: 0 0: Device reset disabled 1: Device reset enabled |

Table 58. CTRL_REG1 Bit Descriptions

| | |
|---------|--|
| OS[2:0] | Oversample Ratio. These bits select the oversampling ratio. Value is 2^{OS} . The default value is 000 for a ratio of 1. |
| RAW | RAW output mode. RAW bit will output ADC data with no post processing, except for oversampling. No scaling or offsets will be applied in the digital domain. The FIFO must be disabled and all other functionality: Alarms, Deltas, and other interrupts are disabled. |
| ALT | Altimeter-Barometer mode. Default value: 0 1: Part is in Altimeter Mode 0: Part is in Barometer mode |

Table 59. System Output Sample Rate Selection

| OS2 | OS1 | OS0 | Oversample Ratio | Minimum Time Between Data Samples |
|-----|-----|-----|------------------|-----------------------------------|
| 0 | 0 | 0 | 1 | 6 ms |
| 0 | 0 | 1 | 2 | 10 ms |
| 0 | 1 | 0 | 4 | 18 ms |
| 0 | 1 | 1 | 8 | 34 ms |
| 1 | 0 | 0 | 16 | 66 ms |
| 1 | 0 | 1 | 32 | 130 ms |
| 1 | 1 | 0 | 64 | 258 ms |
| 1 | 1 | 1 | 128 | 512 ms |

Note: RAW bit overrides the ALT mode and writes uncompensated Pressure and Temperature data

7.17.2 CTRL_REG2 (0x27)

Table 60. CTRL_REG2 Register

| | | | | | | | | |
|-------|---|---|-----------------|-----------|-------|-------|-------|-------|
| | 7 | 6 | 5 | 4 | 3 | 2 | 1 | 0 |
| R | 0 | 0 | LOAD_OUTP UT | ALARM_SEL | ST[3] | ST[2] | ST[1] | ST[0] |
| W | | | | | | | | |
| Reset | 0 | 0 | 0 | 0 | 0 | 0 | 0 | 0 |

Table 61. CTRL_REG2 Bit Descriptions

| Name | Description |
|-------------|--|
| ST[3:0] | Auto acquisition time step. Default value: 0 Step value is 2^{ST} : Giving a range of 1 second to 2^{15} seconds (9 hours) |
| ALARM_SEL | The bit selects the Target value for SRC_PW/SRC_TW and SRC_PTH/SRC_TTH Default value: 0 0: The values in P_TGT_MSB, P_TGT_LSB and T_TGT are used (Default) 1: The values in OUT_P/OUT_T are used for calculating the interrupts SRC_PW/SRC_TW and SRC_PTH/SRC_TTH. |
| LOAD_OUTPUT | This is to load the target values for SRC_PW/SRC_TW and SRC_PTH/SRC_TTH. Default value: 0 0: Do not load OUT_P/OUT_T as target values 1: The next values of OUT_P/OUT_T are used to set the target values for the interrupts. Note: 1. This bit must be set at least once if ALARM_SEL=1 2. To reload the next OUT_P/OUT_T as the target values clear and set again. |

7.17.3 CTRL_REG3 (Interrupt CTRL Register) (0x28)

Table 62. CTRL_REG3 Register

| | | | | | | | | |
|-------|---|---|-------|--------|---|---|-------|--------|
| | 7 | 6 | 5 | 4 | 3 | 2 | 1 | 0 |
| R | 0 | | IPOL1 | PP_OD1 | 0 | | IPOL2 | PP_OD2 |
| W | | | | | | | | |
| Reset | 0 | 0 | 0 | 0 | 0 | 0 | 0 | 0 |

Table 63. CTRL_REG3 Description

| Name | Description |
|--------|---|
| IPOL1 | The IPOL bit selects the polarity of the interrupt signal. When IPOL is '0' (default value) any interrupt event will signalled with a logical '0'. Interrupt Polarity active high, or active low on interrupt pad INT1. Default value: 0 0: Active low 1: Active high |
| PP_OD1 | This bit configures the interrupt pin to Push-Pull or in Open Drain mode. The default value is 0 which corresponds to Push-Pull mode. The open drain configuration can be used for connecting multiple interrupt signals on the same interrupt line. Push-Pull/Open Drain selection on interrupt pad INT1. Default value: 0 0: Internal Pullup 1: Open drain |
| IPOL2 | Interrupt Polarity active high, or active low on interrupt pad INT2. Default value: 0 0: Active low 1: Active high |
| PP_OD2 | Push-Pull/Open Drain selection on interrupt pad INT2. Default value: 0 0: Internal Pull-up 1: Open drain |

7.17.4 CTRL_REG4 [Interrupt Enable Register] (0x29)

The corresponding functional block interrupt enable bit allows the functional block to route its event detection flags to the system's interrupt controller. The interrupt controller routes the enabled functional block interrupt to the INT1 or INT2 pin.

Table 64. CTRL_REG4 Register

| | | | | | | | | |
|-------|-------------|-------------|-----------|-----------|------------|------------|-------------|-------------|
| | 7 | 6 | 5 | 4 | 3 | 2 | 1 | 0 |
| R | INT_EN_DRDY | INT_EN_FIFO | INT_EN_PW | INT_EN_TW | INT_EN_PTH | INT_EN_TTH | INT_EN_PCHG | INT_EN_TCHG |
| W | | | | | | | | |
| Reset | 0 | 0 | 0 | 0 | 0 | 0 | 0 | 0 |

Table 65. Interrupt Enable Register Description

| Interrupt Enable | Description |
|------------------|--|
| INT_EN_DRDY | Interrupt Enable. Default value: 0 0: Data Ready interrupt disabled 1: Data Ready interrupt enabled |
| INT_EN_FIFO | Interrupt Enable. Default value: 0 0: FIFO interrupt disabled 1: FIFO interrupt enabled |
| INT_EN_PW | Interrupt Enable. Default value: 0 0: Pressure window interrupt disabled 1: Pressure window interrupt enabled |

Table 65. Interrupt Enable Register Description

| | |
|-------------|---|
| INT_EN_TW | Interrupt Enable. Default value: 0 0: Temperature window interrupt disabled 1: Temperature window interrupt enabled. |
| INT_EN_PTH | Interrupt Enable. Default value: 0 0: Pressure Threshold interrupt disabled 1: Pressure Threshold interrupt enabled. |
| INT_EN_TTH | Interrupt Enable. Default value: 0 0: Temperature Threshold interrupt disabled 1: Temperature Threshold interrupt enabled. |
| INT_EN_PCHG | Interrupt Enable. Default value: 0 0: Pressure Change interrupt disabled 1: Pressure Change interrupt enabled. |
| INT_EN_TCHG | Interrupt Enable. Default value: 0 0: Temperature Change interrupt disabled 1: Temperature Change interrupt enabled. |

7.17.5 CTRL_REG5 [Interrupt Configuration Register] (0x2A)

Table 66. CTRL_REG5 Register

| | | | | | | | | |
|-------|--------------|--------------|------------|------------|-------------|-------------|--------------|--------------|
| | 7 | 6 | 5 | 4 | 3 | 2 | 1 | 0 |
| R | INT_CFG_DRDY | INT_CFG_FIFO | INT_CFG_PW | INT_CFG_TW | INT_CFG_PTH | INT_CFG_TTH | INT_CFG_PCHG | INT_CFG_TCHG |
| W | | | | | | | | |
| Reset | 0 | 0 | 0 | 0 | 0 | 0 | 0 | 0 |

Table 67. Interrupt Configuration Register Descriptions

| Interrupt Configuration | Description |
|-------------------------|---|
| INT_CFG_DRDY | INT1/INT2 Configuration. Default value: 0 0: Interrupt is routed to INT2 pin; 1: Interrupt is routed to INT1 |
| INT_CFG_FIFO | INT1/INT2 Configuration. Default value: 0 0: Interrupt is routed to INT2 pin; 1: Interrupt is routed to INT1 |
| INT_CFG_PW | INT1/INT2 Configuration. Default value: 0 0: Interrupt is routed to INT2 pin; 1: Interrupt is routed to INT1 |
| INT_CFG_TW | INT1/INT2 Configuration. Default value: 0 0: Interrupt is routed to INT2 pin; 1: Interrupt is routed to INT1 |
| INT_CFG_PTH | INT1/INT2 Configuration. Default value: 0 0: Interrupt is routed to INT2 pin; 1: Interrupt is routed to INT1 |
| INT_CFG_TTH | INT1/INT2 Configuration. Default value: 0 0: Interrupt is routed to INT2 pin; 1: Interrupt is routed to INT1 |
| INT_CFG_PCHG | INT1/INT2 Configuration. Default value: 0 0: Interrupt is routed to INT2 pin; 1: Interrupt is routed to INT1 |
| INT_CFG_TCHG | INT1/INT2 Configuration. Default value: 0 0: Interrupt is routed to INT2 pin; 1: Interrupt is routed to INT1 |

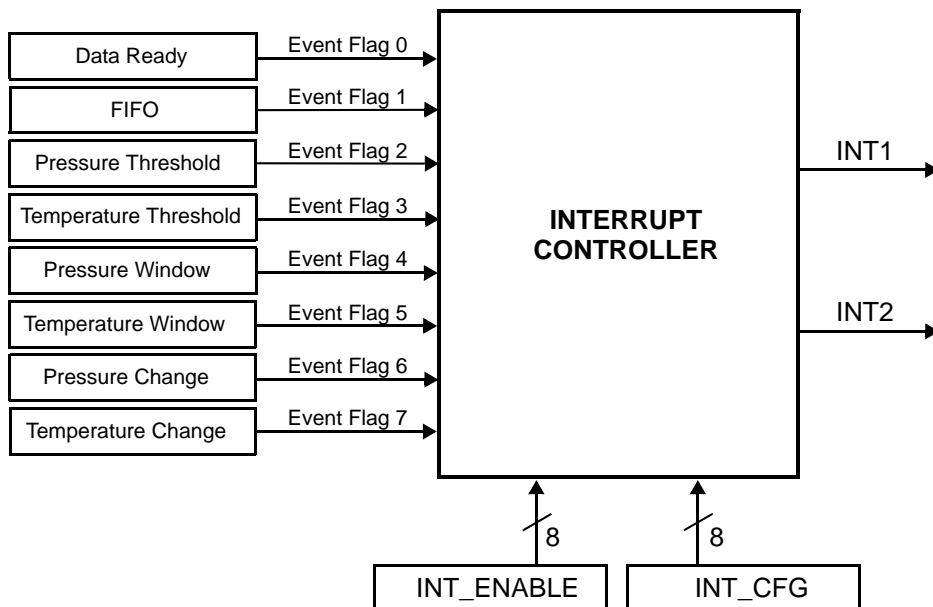

Figure 8. Interrupt Controller Block Diagram

The system's interrupt controller uses the corresponding bit field in the CTRL_REG5 register to determine the routing table for the INT1 and INT2 interrupt pins. If the bit value is logic '0' the functional block's interrupt is routed to INT2, and if the bit value is logic '1' then the interrupt is routed to INT1. All interrupts routed to INT1 or INT2 are logically OR'd as illustrated in Figure 9, thus one or more functional blocks can assert an interrupt pin simultaneously; therefore a host application responding to an interrupt should read the INT_SOURCE register to determine the appropriate sources of the interrupt.

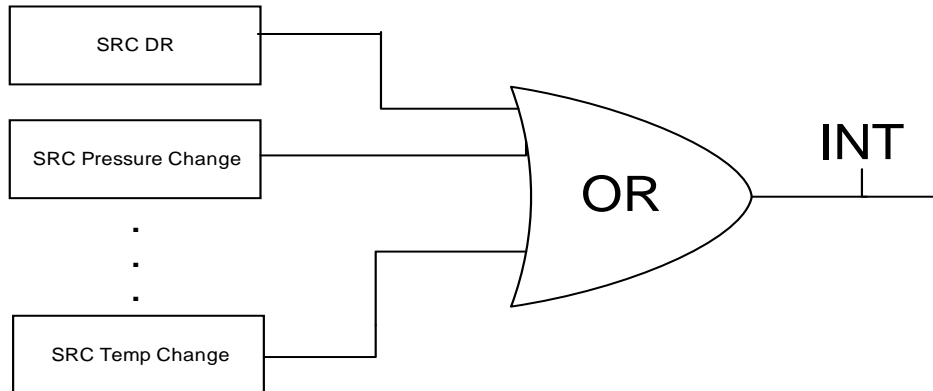

Figure 9. INT1/INT2 PIN Control Logic

7.18 Offset Correction

The 2's complement offset correction registers values are used to trim the temperature, altitude and pressure offsets that might occur over the life of the product.

The resolution of the pressure offset register is 4 Pa per bit.

7.18.1 OFF_P (0x2B)

Pressure user accessible offset trim value expressed as an 8-bit 2's complement number. The user offset registers may be adjusted to enhance accuracy and optimize the system performance. Range is from -512 to +508 Pa, 4 Pa per LSB.

Table 68. OFF_P Register

| | | | | | | | | |
|-------|--------|--------|--------|--------|--------|--------|--------|--------|
| | 7 | 6 | 5 | 4 | 3 | 2 | 1 | 0 |
| R | OFF_P7 | OFF_P6 | OFF_P5 | OFF_P4 | OFF_P3 | OFF_P2 | OFF_P1 | OFF_P0 |
| W | | | | | | | | |
| Reset | 0 | 0 | 0 | 0 | 0 | 0 | 0 | 0 |

Table 69. OFF_P Description

| Name | Description |
|---------------|--|
| OFF_P7-OFF_P0 | Pressure offset trim value. Default value: 0000_0000. |

7.18.2 OFF_T (0x2C)

Temperature user accessible offset trim value expressed as an 8-bit 2's complement number. The user offset registers may be adjusted to enhance accuracy and optimize the system performance. Range is from -8 to +7.9375°C, 0.0625°C per LSB.

Table 70. OFF_T Register

| | | | | | | | | |
|-------|--------|--------|--------|--------|--------|--------|--------|--------|
| | 7 | 6 | 5 | 4 | 3 | 2 | 1 | 0 |
| R | OFF_T7 | OFF_T6 | OFF_T5 | OFF_T4 | OFF_T3 | OFF_T2 | OFF_T1 | OFF_T0 |
| W | | | | | | | | |
| Reset | 0 | 0 | 0 | 0 | 0 | 0 | 0 | 0 |

Table 71. OFF_Y Description

| Name | Description |
|---------------|---|
| OFF_T7-OFF_T0 | Temperature offset trim value. Default value: 0000_0000. |

7.18.3 OFF_H (0x2D)

Altitude Data User Offset Register (OFF_H) is expressed as a 2's complement number in meters. The user offset register provides user adjustment to the vertical height of the Altitude output. The range of values are from -128 to +127 meters.

Table 72. OFF_H Register

| | | | | | | | | |
|-------|--------|--------|--------|--------|--------|--------|--------|--------|
| | 7 | 6 | 5 | 4 | 3 | 2 | 1 | 0 |
| R | OFF_H7 | OFF_H6 | OFF_H5 | OFF_H4 | OFF_H3 | OFF_H2 | OFF_H1 | OFF_H0 |
| W | | | | | | | | |
| Reset | 0 | 0 | 0 | 0 | 0 | 0 | 0 | 0 |

Table 73. OFF_Y Description

| Name | Description |
|---------------|--|
| OFF_H7-OFF_H0 | Height offset trim value. Default value: 0000_0000. |

8 Soldering/Landing Pad Information

The LGA package is compliant with the RoHS standard. Note that Pin 1 index area marker does not have any internal electrical connections. Handling and soldering recommendations for pressure sensors are available in application note AN3150.

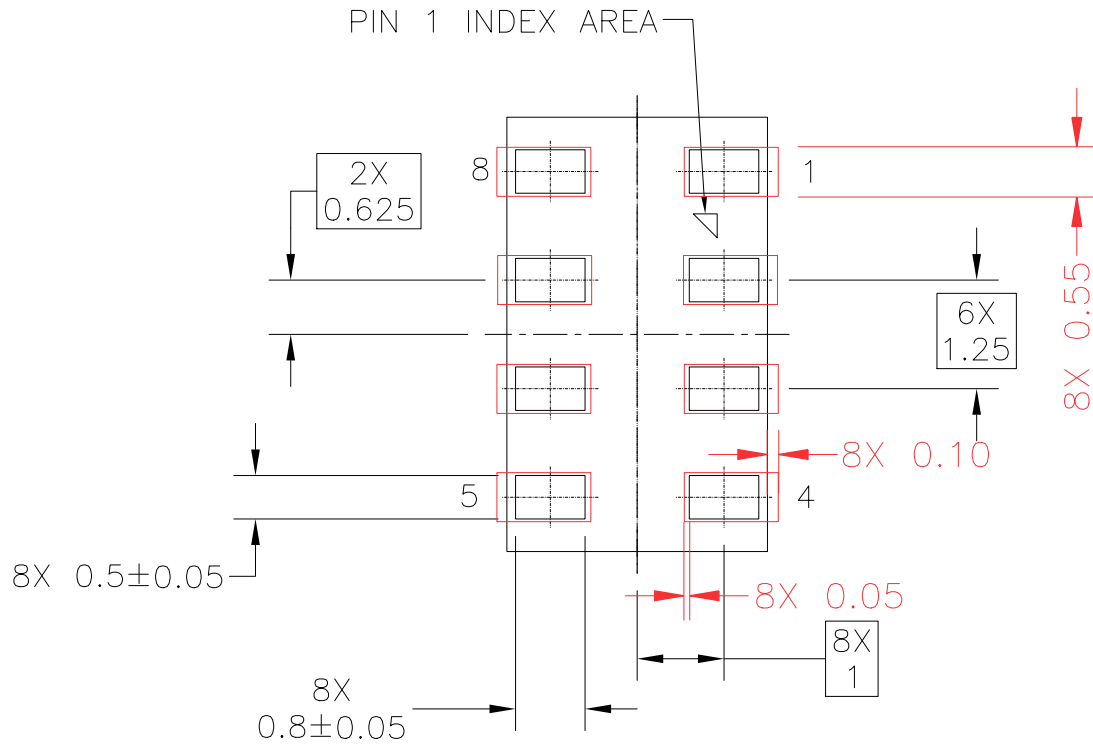

BLACK for Package Outline
 RED for PCB Landing Pattern

Figure 10. MPL3115A2 Recommended PCB Landing Pattern.

PACKAGE DIMENSIONS

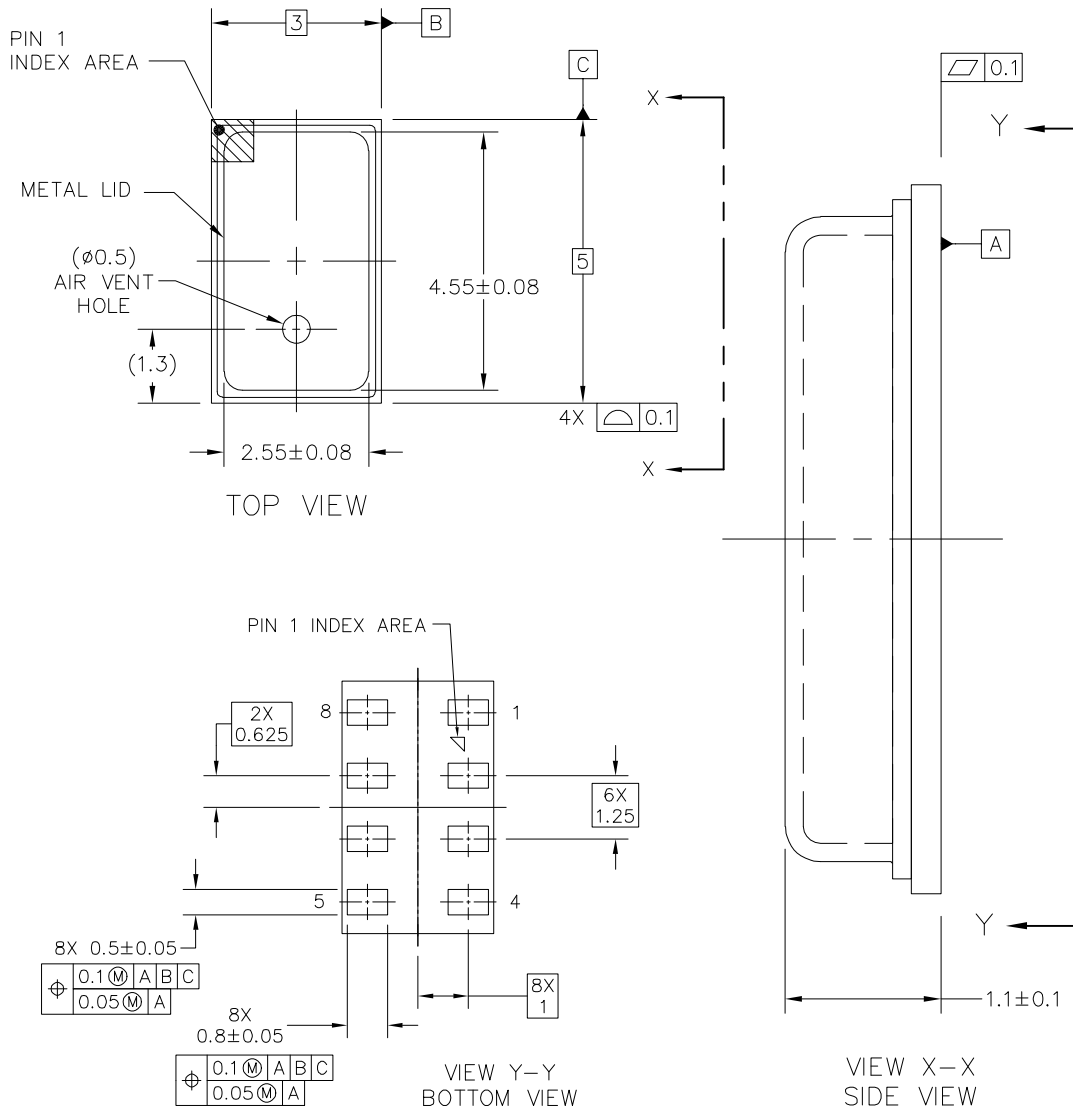

| | | | |
|---|---------------------------|----------------------------|--|
| © FREESCALE SEMICONDUCTOR, INC. ALL RIGHTS RESERVED. | MECHANICAL OUTLINE | PRINT VERSION NOT TO SCALE | |
| TITLE: LGA 8 I/O, 3 X 5 X 1.25 PITCH, SENSOR 1.2MAX MM PKG | DOCUMENT NO: 98ASA00260D | REV: 0 | |
| | CASE NUMBER: 2153-01 | 17 AUG 2010 | |
| | STANDARD: NON-JEDEC | | |

**CASE 2053-01
ISSUE 0
LGA PACKAGE**

PACKAGE DIMENSIONS

NOTES:

1. ALL DIMENSIONS IN MILLIMETERS.
2. DIMENSIONING AND TOLERANCING PER ASME Y14.5M-1994
3. STYLE:
PIN 1: VDD PIN 5: INT2
PIN 2: CAP PIN 6: INT1
PIN 3: GND PIN 7: SDA
PIN 4: VDDIO PIN 8: SCL

| | | | |
|---|---------------------------|----------------------------|--|
| © FREESCALE SEMICONDUCTOR, INC. ALL RIGHTS RESERVED. | MECHANICAL OUTLINE | PRINT VERSION NOT TO SCALE | |
| TITLE: LGA 8 I/O, 3 X 5 X 1.25 PITCH, SENSOR 1.2MAX MM PKG | DOCUMENT NO: 98ASA00260D | REV: 0 | |
| | CASE NUMBER: 2153-01 | 17 AUG 2010 | |
| | STANDARD: NON-JEDEC | | |

**CASE 2053-01
ISSUE 0
LGA PACKAGE**

MPL3115A2

9 Tape and Reel Specifications

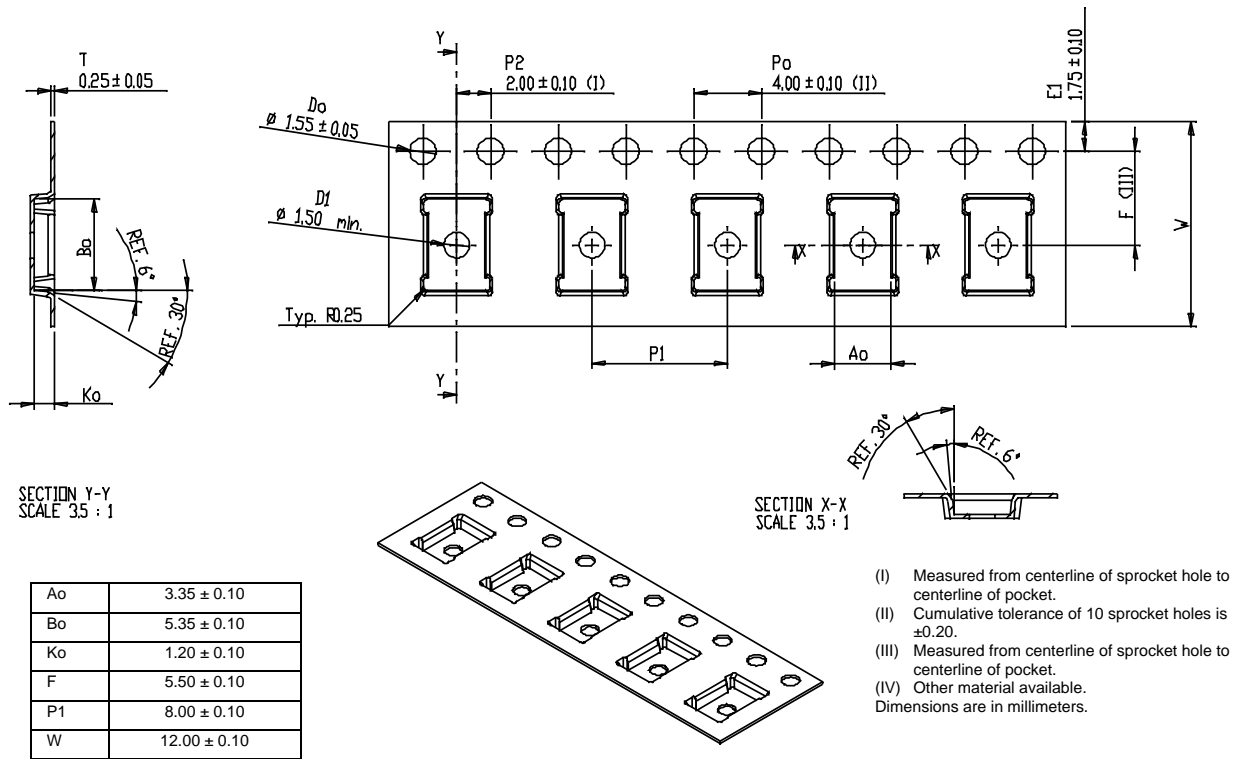

Figure 11. LGA (3 by 5) Embossed Carrier Tape Dimensions

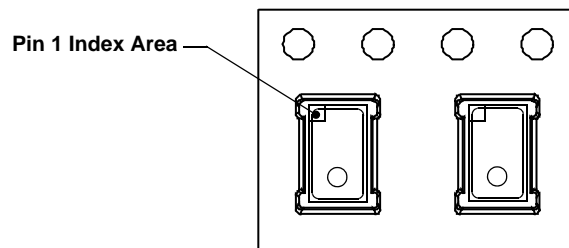

Figure 12. Device Orientation in Chip Carrier

Table 74. Revision History

| Revision number | Revision date | Description of changes |
|-----------------|---------------|--|
| 0 | 06/2011 | <ul style="list-style-type: none"> • Initial Release |
| 1 | 12/2011 | <ul style="list-style-type: none"> • Added bullet and new row under Ordering Information on pg 1. • Global change to register names 0x16, 0x17, 0x18, 0x19, 0x1A; changed ARM to TGT. • Global change to bit names in registers 0x12 and 0x2A. • Section 2.1, Table 1, changed Min and Max values for Pressure Absolute Accuracy. • Table 3 changed units to ns for SDA Data Hold Time • Added Figure 4. I²C Bus Transmission Signals • Section 4.3: added equation • Section 5: Added new paragraph. Added new equations in 5.6.1 and 5.6.2. • Section 6: Added footnote to Table 11, changed TOW description in Table 12, updated paragraphs of Sections 6.1.3 and 6.1.4, Table 57 added sentence in RAW description column, Table 58 added column for Fastest OST Data Output I²C, updated Figure 5 and Figure 6. |
| 2 | 04/2012 | <ul style="list-style-type: none"> • Section 2.1, Table 2, changed from: -10°C, to: over -10°C for Pressure Absolute Accuracy parameter, changed parameter name from: Pressure Resolution, to: Pressure/Altitude Resolution, changed Test Conditions name from: Barometric Measurement Mode, to: Barometer Mode and from: Altimeter Measurement Mode, to: Altimeter Mode, added to Table 2, Footnote 1: over 50kPa to 110 kPa, added new Footnote 2: Oversample (OSR) modes internally combine and average samples to reduce noise. • Table 3: removed footnote reference on Table 3 table heading to Footnote 1, added Footnote 2 reference to Highest Speed Mode test condition, added Footnote 3 reference to Highest Resolution Mode test condition, • Table 4: deleted row 8: SDA Valid Time, row 9: SDA Valid Acknowledge Time and Footnote 5. tVD,DAT, changed SDA and SCL Rise Time Max value from: 1000, to: 300. • Sections 6.6.2, 6.6.3, 6.6.4: Added Note. • Added Sections 6.6.7 Data Ready and Section 6.6.8 FIFO Event. • Section 7, Table 9: Changed Register Address column from: 0x00//0x06, to: 0x06/0x00, from: 0x0D//00, to: 0x0D, from: 0x0E/01, to: 0x0E/0x01, added OST to Footnote 4. • Section 7.1: Table 11: from (0x0B), to: (0x0D), from: Pressure/Temperature data delta, to: Pressure/Temperature data or FIFO data. • Section 7.3.3: Added (ST bits of CTRL_REG2) to sentence 2., Table 31 added 1 new sentence in F_MODE[1.0] description • Deleted notes from Sections 7.9.1, 7.10.1, 7.11.1 and 7.12.1. • Section 7.17.1, Table 58: OST Description, changed from: ACTV, to: SBYB, Table 59: Delete Column: Fastest OST Data Output Rate I²C, deleted Footnotes 1 and 2, changed values in Minimum Time Between Data Samples column. • Section 7.18.1: Changed from: 512, to: -512 to +508 • Section 7.18.2: Changed from: -8, to: +7.9375°C. • Section 7.18.3: Changed from: -128, to: +128 meters. • Section 8: Added: Note that Pin 1 index area marker does not have any internal electrical connections. Handling and soldering recommendations for pressure sensors are available in application note AN3150. • Section 9: Added Section called Tape and Reel specifications. |
| 2.1 | 05/2012 | <ul style="list-style-type: none"> • Changed Ordering Information device name from MPL3115A2T1 to MPL3115A2R1 |
| 2.2 | 07/2012 | <ul style="list-style-type: none"> • Page 33, Table 59 Change from: 8 ms, To: 18 ms, Page 38, Table 72, Change title from: OFF_T Register, To: OFF_H Register |

How to Reach Us:

Home Page:
www.freescale.com

Web Support:
<http://www.freescale.com/support>

Information in this document is provided solely to enable system and software implementers to use Freescale products. There are no express or implied copyright licenses granted hereunder to design or fabricate any integrated circuits based on the information in this document.

Freescale reserves the right to make changes without further notice to any products herein. Freescale makes no warranty, representation, or guarantee regarding the suitability of its products for any particular purpose, nor does Freescale assume any liability arising out of the application or use of any product or circuit, and specifically disclaims any and all liability, including without limitation consequential or incidental damages. "Typical" parameters that may be provided in Freescale data sheets and/or specifications can and do vary in different applications, and actual performance may vary over time. All operating parameters, including "typicals," must be validated for each customer application by customer's technical experts. Freescale does not convey any license under its patent rights nor the rights of others. Freescale sells products pursuant to standard terms and conditions of sale, which can be found at the following address: <http://www.reg.net/v2/webservices/Freescale/Docs/TermsandConditions.htm>.

Freescale, the Freescale logo, and the Energy Efficient Solutions logo are trademarks of Freescale Semiconductor, Inc., Reg. U.S. Pat. & Tm. Off. Xtrinsic is a trademark of Freescale Semiconductor, Inc.

All other product or service names are the property of their respective owners.

© 2012 Freescale Semiconductor, Inc. All rights reserved.

RoHS-compliant and/or Pb-free versions of Freescale products have the functionality and electrical characteristics of their non-RoHS-compliant and/or non-Pb-free counterparts. For further information, see <http://www.freescale.com> or contact your Freescale sales representative.

For information on Freescale's Environmental Products program, go to <http://www.freescale.com/epp>.



Стандарт Электрон Связь

Мы молодая и активно развивающаяся компания в области поставок электронных компонентов. Мы поставляем электронные компоненты отечественного и импортного производства напрямую от производителей и с крупнейших складов мира.

Благодаря сотрудничеству с мировыми поставщиками мы осуществляем комплексные и плановые поставки широчайшего спектра электронных компонентов.

Собственная эффективная логистика и склад в обеспечивает надежную поставку продукции в точно указанные сроки по всей России.

Мы осуществляем техническую поддержку нашим клиентам и предпродажную проверку качества продукции. На все поставляемые продукты мы предоставляем гарантию .

Осуществляем поставки продукции под контролем ВП МО РФ на предприятия военно-промышленного комплекса России , а также работаем в рамках 275 ФЗ с открытием отдельных счетов в уполномоченном банке. Система менеджмента качества компании соответствует требованиям ГОСТ ISO 9001.

Минимальные сроки поставки, гибкие цены, неограниченный ассортимент и индивидуальный подход к клиентам являются основой для выстраивания долгосрочного и эффективного сотрудничества с предприятиями радиоэлектронной промышленности, предприятиями ВПК и научно-исследовательскими институтами России.

С нами вы становитесь еще успешнее!

Наши контакты:

Телефон: +7 812 627 14 35

Электронная почта: sales@st-electron.ru

Адрес: 198099, Санкт-Петербург,
Промышленная ул, дом № 19, литера Н,
помещение 100-Н Офис 331