

TO PIDSA HQ

DELIVERY SPECIFICATIONS

Orderer (Customer) Part Number _____

Panasonic Global Part Number AN41908A-VB

Vendor Issue Number 1203027

Confirmation of Security Control

We confirm and certify that the products of these specifications shall not be supplied so as to be used for Military Purpose (defined herein below). "Military Purpose" in this statement means the design, development, manufacture, storage or use of any weapons, including without limitation nuclear weapons, biological weapons, chemical weapons and missiles.

ORDERER (CUSTOMER)

Receipt Date: / /

VENDOR

"Changes in the description of Delivery Specifications" and "changes that affect performance, quality or environment" are implemented according to advance consultation.

パナソニック株式会社
2012. 3. 13
デバイス社 半導体事業グループ 汎用LSI BU

Issuance Date: / /

SMART Puniness distraction
S423140-07#01

Request for your special attention and precautions in using the technical information and semiconductors described in this book

(1) If any of the products or technical information described in this book is to be exported or provided to non-residents, the laws and regulations of the exporting country, especially, those with regard to security export control, must be observed.

(2) The technical information described in this book is intended only to show the main characteristics and application circuit examples of the products. No license is granted in and to any intellectual property right or other right owned by Panasonic Corporation or any other company. Therefore, no responsibility is assumed by our company as to the infringement upon any such right owned by any other company which may arise as a result of the use of technical information described in this book.

(3) The products described in this book are intended to be used for general applications (such as office equipment, communications equipment, measuring instruments and household appliances), or for specific applications as expressly stated in this book.

Consult our sales staff in advance for information on the following applications:

• Special applications (such as for airplanes, aerospace, automotive equipment, traffic signaling equipment, combustion equipment, life support systems and safety devices) in which exceptional quality and reliability are required, or if the failure or malfunction of the products may directly jeopardize life or harm the human body.

It is to be understood that our company shall not be held responsible for any damage incurred as a result of or in connection with your using the products described in this book for any special application, unless our company agrees to your using the products in this book for any special application.

(4) When designing your equipment, comply with the range of absolute maximum rating and the guaranteed operating conditions (operating power supply voltage and operating environment etc.). Especially, please be careful not to exceed the range of absolute maximum rating on the transient state, such as power-on, power-off and mode-switching. Other-wise, we will not be liable for any defect which may arise later in your equipment.

Even when the products are used within the guaranteed values, take into the consideration of incidence of break down and failure mode, possible to occur to semiconductor products. Measures on the systems such as redundant design, arresting the spread of fire or preventing glitch are recommended in order to prevent physical injury, fire, social damages, for example, by using the products.

(5) Comply with the instructions for use in order to prevent breakdown and characteristics change due to external factors (ESD, EOS, thermal stress and mechanical stress) at the time of handling, mounting or at customer's process. When using products for which damp-proof packing is required, satisfy the conditions, such as shelf life and the elapsed time since first opening the packages.

(6) This book may be not reprinted or reproduced whether wholly or partially, without the prior written permission of our company.

Reprint from WARNING LABEL STANDARDS SC3-11-00007

This delivery specifications may include old company names such as "Matsushita Electronics Corporation" or "Semiconductor Company, Matsushita Electric Industrial Co., Ltd." "Semiconductor Company, Panasonic Corporation" Please interpret these old company names as Industrial Devices Company, Panasonic Corporation" as of January 1, 2012.

Regulations No.	IC3F5463	Total Pages	Page
		54	1

Product Standards

Part No.	AN41908A
Package Code No.	*QFN044-P-0606D

Semiconductor Company
Panasonic Corporation

Established by	Applied by	Checked by	Prepared by
<i>H. Shidomka</i>	M. Hiramatsu	K. Tan	M.Nakahara

2009-10-23	
Established	Revised

	<h1>Product Standards</h1>	AN41908A	
		Total Pages	Page
		54	2

Contents

■ Overview		3
■ Features		3
■ Applications		3
■ Package		3
■ Type		3
■ Application Circuit Example		4
■ Block Diagram		5
■ Pin Descriptions		6
■ Absolute Maximum Ratings		8
■ Operating Supply Voltage Range		8
■ Allowable Current and Voltage Range		9
■ Electrical Characteristics		10
■ Electrical Characteristics (Reference values for design)		12
■ Test Circuit Diagram		14
■ Electrical Characteristics Test Procedures		24
■ Technical Data		42
• I/O block circuit diagrams and pin function descriptions		42
■ Usage Notes		53
• Special attention and precaution in using		53
• Notes of Power LSI		54

2009-10-23		
Established	Revised	

	Product Standards	AN41908A	
		Total Pages	Page
		54	3

AN41908A

Lens Driver IC for camcorder and security-camera incorporating Iris control

■ Overview

AN41908A is a lens motor driver IC for camcorder and security-camera featuring the functions of Iris control. Voltage drive system and several torque ripple correction techniques enable super- low noise microstep drive.

■ Features

- Voltage drive system 256-step microstep drivers (2 systems)
- Built-in Iris controller
- Motor control by 4-line serial data communication
- 2 systems of open-drain for driving LED

■ Applications

- Camcorder, Security-camera

■ Package

- 44 pin Plastic Quad Flat Non-leaded Package (QFN Type)

■ Type

- Bi-COMS IC

2009-10-23		
Established	Revised	

■ Application Circuit Example

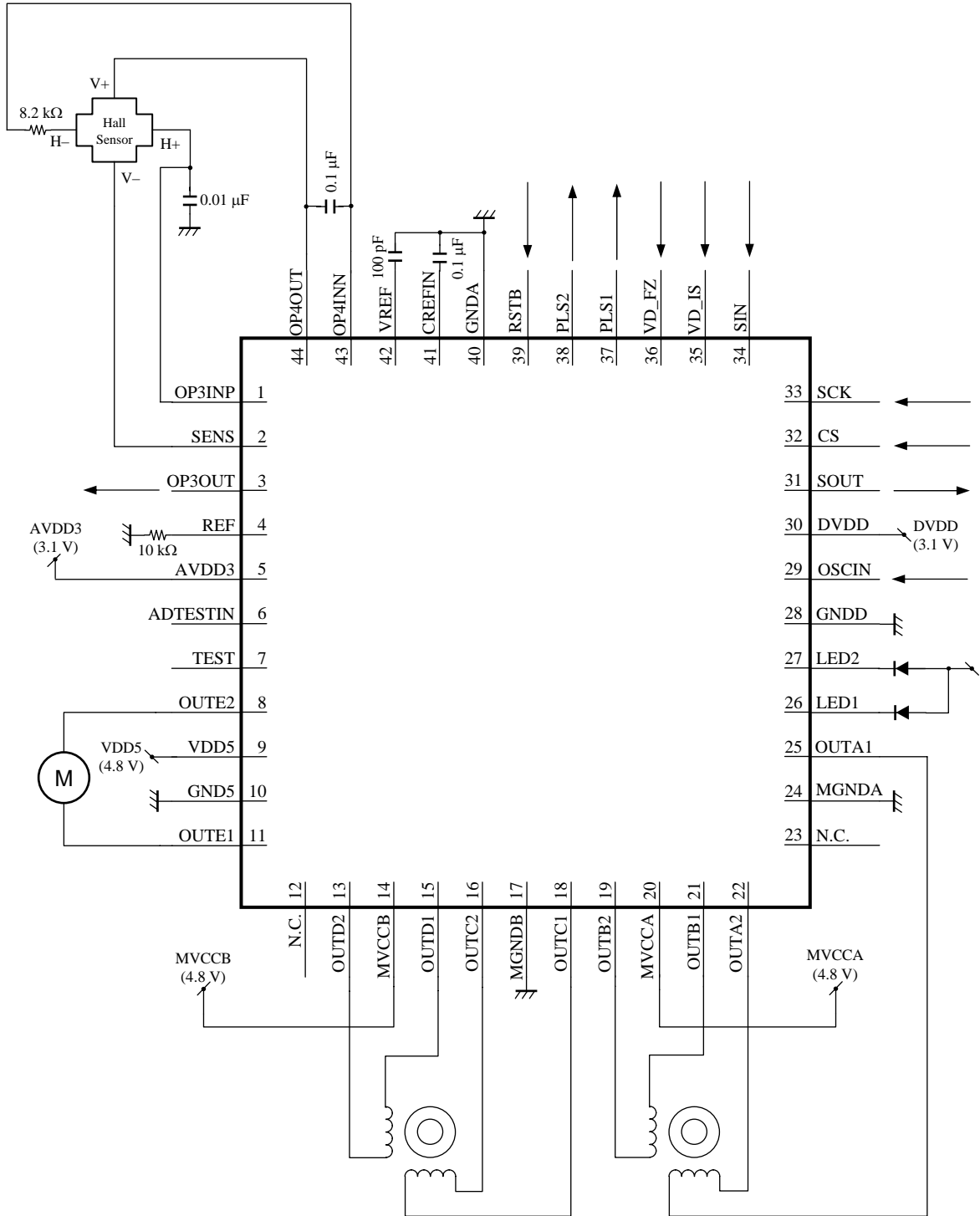

Note) This application circuit is shown as an example but does not guarantee the design for mass production set.

2009-10-23		
Established	Revised	

■ Block Diagram

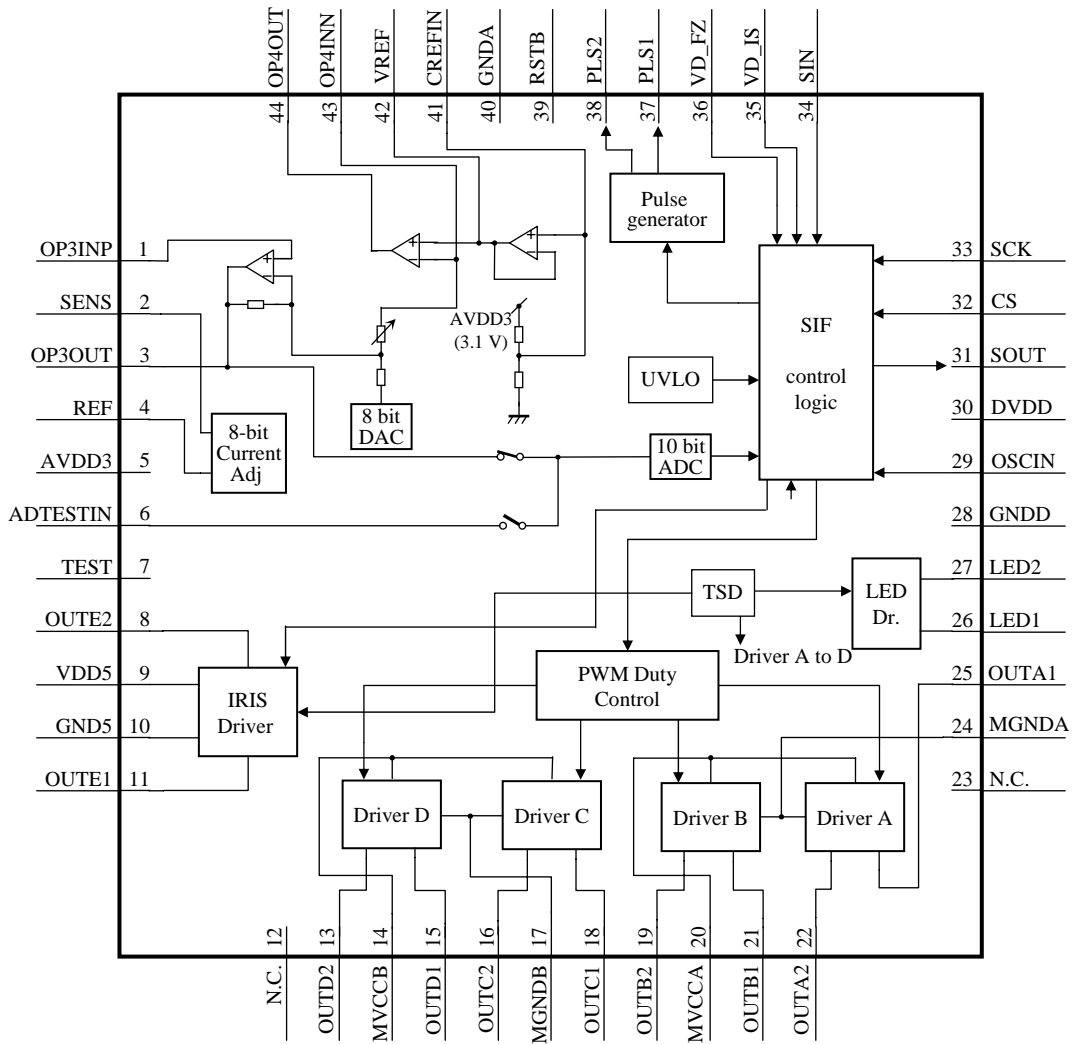

Note) This block diagram is for explaining functions. The part of the block diagram may be omitted, or it may be simplified.

2009-10-23		
Established	Revised	

	<h1>Product Standards</h1>	<h2>AN41908A</h2>	
		Total Pages	Page
		54	6

■ Pin Descriptions

Pin No.	Pin name	Type	Description
1	OP3INP	Input	Hall signal amplifier non-inverting input
2	SENS	Output	Hall current bias output
3	OP3OUT	Output	Hall signal amplifier output
4	REF	—	Resistor connection for Hall current bias setting
5	AVDD3	Power supply	3 V analog power supply
6	ADTESTIN	Input	ADC test input
7	TEST	Input	Test mode input
8	OUTE2	Output	Motor output E2
9	VDD5	Power supply	Power supply for Iris
10	GND5	Ground	GND for Iris
11	OUTE1	Output	Motor output E1
12	N. C.	—	N. C.
13	OUTD2	Output	Motor output D2
14	MVCCB	Power supply	Power supply for motor B
15	OUTD1	Output	Motor output D1
16	OUTC2	Output	Motor output C2
17	MGNDB	Ground	GND for motor B
18	OUTC1	Output	Motor output C1
19	OUTB2	Output	Motor output B2
20	MVCCA	Power supply	Power supply for motor A
21	OUTB1	Output	Motor output B1
22	OUTA2	Output	Motor output A2
23	N. C.	—	N. C.
24	MGNDA	Ground	GND for motor A
25	OUTA1	Output	Motor output A1
26	LED1	Input	Open-drain 1 for driving LED
27	LED2	Input	Open-drain 2 for driving LED
28	GNDD	Ground	Digital GND
29	OSCIN	Input	OSCIN input
30	DVDD	Power supply	3 V digital power supply
31	SOUT	Output	Serial data output
32	CS	Input	Chip select signal input
33	SCK	Input	Serial clock input
34	SIN	Input	Serial data input
35	VD_IS	Input	Iris video sync. signal input

2009-10-23		
Established	Revised	

	<h1>Product Standards</h1>	AN41908A	
		Total Pages	Page
		54	7

■ Pin Descriptions (continued)

Pin No.	Pin name	Type	Description
36	VD_FZ	Input	Focus zoom sync. signal input
37	PLS1	Output	Pulse 1 output
38	PLS2	Output	Pulse 2 output
39	RSTB	Input	Reset signal input
40	GND A	Ground	3 V analog GND
41	CREFIN	—	(AVDD3)/2 capacitor connection pin
42	VREF	Output	Reference voltage for Hall sensor
43	OP4INN	Input	Midpoint bias amplifier inverting input
44	OP4OUT	Output	Midpoint bias amplifier output

2009-10-23		
Established	Revised	

	<h1>Product Standards</h1>	<h2>AN41908A</h2>	
		Total Pages	Page
		54	8

■ Absolute Maximum Ratings

Note) Absolute maximum ratings are limit values which do not result in damages to this IC, and IC operation is not guaranteed at these limit values.

A No.	Parameter	Symbol	Rating	Unit	Notes
1	Controller supply voltage	AVDD3	-0.3 to + 4.0	V	*1
		DVDD	-0.3 to + 4.0		
2	Supply voltage for motor controller 1	MVCCx	-0.3 to + 6.0	V	*1
3	Supply voltage for motor controller 2	VDD5	-0.3 to + 6.0	V	*1
4	Power dissipation	P _D	141.4	mW	*2
5	Operating ambient temperature	T _{opr}	-20 to + 85	°C	*3
6	Storage temperature	T _{stg}	-55 to + 125	°C	*3
7	Motor driver 1 (focus, zoom) H bridge drive current	I _{M1(CD)}	±0.25	A/ch	—
8	Motor driver 2 (iris) H bridge drive current	I _{M2(CD)}	±0.15	A/ch	—
9	Instantaneous H bridge drive current	I _{M(pulse)}	±0.4	A/ch	—
10	Digital input voltage	V _{in}	-0.3 to (DVDD + 0.3)	V	*4

Notes) *1 : The values under the condition not exceeding the above absolute maximum ratings and the power dissipation.

*2 : The power dissipation shown is the value at T_a = 85°C for the independent (unmounted) IC package without a heat sink.

When using this IC, refer to the P_D-T_a diagram of the package standard and design the heat radiation with sufficient margin so that the allowable value might not be exceeded based on the conditions of power supply voltage, load, and ambient temperature.

*3 : Except for the power dissipation, operating ambient temperature, and storage temperature, all ratings are for T_a = 25°C.

*4 : (DVDD + 0.3) V must not be exceeded 4.0 V.

■ Operating Supply Voltage Range

Parameter	Symbol	Range			Unit	Notes
		Min	Typ	Max		
Supply voltage range	AVDD3	2.7	3.1	3.6	V	*1
	DVDD	2.7	3.1	3.6		
	MVCCx	3.0	4.8	5.5		
	VDD5	3.0	4.8	5.5		

Note) *1 : The values under the condition not exceeding the above absolute maximum ratings and the power dissipation.

2009-10-23		
Established	Revised	

	<h1>Product Standards</h1>	<h2>AN41908A</h2>	
		Total Pages	Page
		54	9

■ Allowable Current and Voltage Range

- Notes) • Allowable current and voltage ranges are limit ranges which do not result in damages to this IC, and IC operation is not guaranteed within these limit ranges.
- Voltage values, unless otherwise specified, are with respect to GND.
 - GND is voltage for GNDA, GNDD, GND5, MGND A, and MGND B. GND = GNDA = GNDD = GND5 = MGND A = MGND B
 - VCC3V is voltage for AVDD3 and DVDD. AVDD3 = DVDD
 - Do not apply external currents or voltages to any pin not specifically mentioned.
 - For the circuit currents, "+" denotes current flowing into the IC, and "-" denotes current flowing out of the IC.

Pin No.	Pin name	Rating	Unit	Notes
1	OP3INP	-0.3 to (AVDD3 + 0.3)	V	*1
6	ADTESTIN	-0.3 to (AVDD3 + 0.3)	V	*1
7	TEST	-0.3 to (DVDD + 0.3)	V	*1
29	OSCIN	-0.3 to (DVDD + 0.3)	V	*1
32	CS	-0.3 to (DVDD + 0.3)	V	*1
33	SCK	-0.3 to (DVDD + 0.3)	V	*1
34	SIN	-0.3 to (DVDD + 0.3)	V	*1
35	VD_IS	-0.3 to (DVDD + 0.3)	V	*1
36	VD_FZ	-0.3 to (DVDD + 0.3)	V	*1
39	RSTB	-0.3 to (DVDD + 0.3)	V	*1
43	OP4INN	-0.3 to (AVDD3 + 0.3)	V	*1

Pin No.	Pin name	Rating	Unit	Notes
8	OUTE2	±0.15	A	—
11	OUTE1	±0.15	A	—
13	OUTD2	±0.25	A	—
15	OUTD1	±0.25	A	—
16	OUTC2	±0.25	A	—
18	OUTC1	±0.25	A	—
19	OUTB2	±0.25	A	—
21	OUTB1	±0.25	A	—
22	OUTA2	±0.25	A	—
25	OUTA1	±0.25	A	—
26	LED1	30	mA	—
27	LED2	30	mA	—

Note) *1 : (AVDD3 + 0.3) V must not be exceeded 4.0 V, and (DVDD + 0.3) V must not be exceeded 4.0 V.

2009-10-23		
Established	Revised	

Product Standards		AN41908A	
		Total Pages	Page
		54	10

■ Electrical Characteristics at VDD5 = MVCCx = 4.8 V, DVDD = AVDD3 = 3.1 V

Note) T_a = 25°C±2°C unless otherwise specified.

B No.	Parameter	Symbol	Test circuits	Conditions	Limits			Unit	Notes
					Min	Typ	Max		
Current circuit, Common circuit									
P1	MVCC supply current on Reset	I _{Omdisable}	1	No load, no 27 MHz input	—	0	3.0	μA	—
P2	MVCC supply current on Enable	I _{menable}	1	Output open	—	0.5	1.5	mA	—
P3	3 V supply current on Reset	I _{cc3_reset}	1	No 27 MHz input	—	0	10.0	μA	—
P4	3 V supply current on Enable	I _{cc3_enable}	1	Output open	—	7.0	20.0	mA	—
P5	VDD5 supply current on Reset	I _{cc5_reset}	1	No 27 MHz input	—	0	3.0	μA	—
P6	VDD5 supply current on Enable	I _{cc5_enable}	1	Output open	—	0.3	1.0	mA	—
P7	Supply current on Standby	I _{cc_standby}	1	RSTB = High, output open, 27 MHz input, Total current	—	5.0	10.0	mA	—
P8	Supply current when FZ is Enable and Iris is in power save mode	I _{cc_ps}	1	RSTB = High, output open, 27 MHz input, FZ = Enable, Total current	—	6.0	12.0	mA	—
Digital input / output									
D1	High-level input	V _{in(H)}	2	RSTB	0.54 × DVDD	—	DVDD + 0.3	V	—
D2	Low-level input	V _{in(L)}	2	RSTB	-0.3	—	0.2 × DVDD	V	—
D3	SOUT High-level output	V _{out(H) : SDATA}	2	[SOUT] 1 mA Source	DVDD - 0.5	—	—	V	—
D4	SOUT Low-level output	V _{out(L) : SDATA}	2	[SOUT] 1 mA Sink	—	—	0.5	V	—
D5	PLS1 to 2 High-level output	V _{out(H) : MUX}	2	—	0.9 × DVDD	—	—	V	—
D6	PLS1 to 2 Low-level output	V _{out(L) : MUX}	2	—	—	—	0.1 × DVDD	V	—
D7	Input pull-down resistance	R _{pullret}	3	RSTB	50	100	200	kΩ	—
Motor driver 1 (focus, zoom)									
H1	H bridge ON resistance	R _{onFZ}	4	IM = 100 mA	—	—	2.5	Ω	—
H2	H bridge leak current	I _{leakFZ}	6	—	—	—	0.8	μA	—
Motor driver 2 (iris)									
H3	H bridge ON resistance	R _{onIR}	5	IM = 50 mA	—	—	5	Ω	—
H4	H bridge leak current	I _{leakIR}	6	—	—	—	0.8	μA	—
LED driver									
L1	Output ON resistance	R _{onLED}	7	I = 20 mA, 5 V cell	—	—	8	Ω	—
L2	Output leak current	I _{leakLED}	6	—	—	—	0.8	μA	—

2009-10-23		
Established	Revised	

		<h1>Product Standards</h1>		AN41908A	
				Total Pages	Page
		54	11		

■ Electrical Characteristics (continued) at VDD5 = MVCCx = 4.8 V, DVDD = AVDD3 = 3.1 V

Note) T_a = 25°C±2°C unless otherwise specified.

B No.	Parameter	Symbol	Test circuits	Conditions	Limits			Unit	Notes
					Min	Typ	Max		
OPAMP3 (HALL Sensor Amp. for output amplifier)									
O1	Input voltage range	V _{IN}	8	—	$\frac{1}{2}$ AVDD3 -0.5	$\frac{1}{2}$ AVDD3	$\frac{1}{2}$ AVDD3 +0.5	V	—
O2	Input offset voltage	V _{OF}	8	—	-15	—	15	mV	—
O3	Output voltage (Low)	V _{OL}	9	ILOAD = -100 μA	—	0.1	0.2	V	—
O4	Output voltage (High)	V _{OH}	9	ILOAD = 100 μA	AVDD3 -0.2	AVDD3 -0.1	—	V	—
O5	Gain	V _{OG}	8	Gain setting value : 0h	19.7	21.9	24.1	V/V	—
OPAMP4 (HALL Sensor Amp. for eliminating common-mode voltage)									
O6	Input voltage range	V _{IN}	10	—	$\frac{1}{2}$ AVDD3 -0.1	—	$\frac{1}{2}$ AVDD3 +0.1	V	—
O7	Input offset voltage	V _{OF}	10	—	-10	—	10	mV	—
O8	Output voltage (Low)	V _{OL}	10	ILOAD = -10 μA	—	0.1	0.2	V	—
O9	Output voltage (High)	V _{OH}	10	ILOAD = 3 mA	AVDD3 -0.5	AVDD3 -0.2	—	V	—
Reference voltage output block									
O10	Output voltage 1	VREF	10	ILOAD = 0 A, CVREF = 100 pF	$\frac{1}{2}$ AVDD3 -0.1	$\frac{1}{2}$ AVDD3	$\frac{1}{2}$ AVDD3 +0.1	V	—
O11	Output voltage 2	VREFL	10	ILOAD = ±100 μA, CVREF = 100 pF	VREF -0.1	VREF	VREF +0.1	V	—
Hall bias controller (SENS pin output)									
O12	Min. output current	IBL	10	REF = 10 kΩ, SENS = 0.7 V Setting value : 00 h	—	0	0.1	mA	—
O13	Output current accuracy 1	IB40H	10	REF = 10 kΩ, SENS = 0.7 V Setting value : 40 h	0.9	1.02	1.14	mA	—
O14	Output current accuracy 2	IBBFH	10	REF = 10 kΩ, SENS = 0.7 V Setting value : BE h	2.66	3.02	3.38	mA	—

2009-10-23		
Established	Revised	

	<h1>Product Standards</h1>	<h2>AN41908A</h2>	
		Total Pages	Page
		54	12

■ Electrical Characteristics (Reference values for design) at VDD5 = MVCCx = 4.8 V, DVDD = AVDD3 = 3.1 V

Notes) $T_a = 25^{\circ}\text{C} \pm 2^{\circ}\text{C}$ unless otherwise specified.

The characteristics listed below are reference values derived from the design of the IC and are not guaranteed by inspection.

If a problem does occur related to these characteristics, we will respond in good faith to user concerns.

B No.	Parameter	Symbol	Test circuits	Conditions	Reference values			Unit	Notes
					Min	Typ	Max		
Serial port input									
S1	Serial clock	Sclock	—	—	1	—	5	MHz	—
S2	SCK low time	T1	—	—	100	—	—	ns	—
S3	SCK high time	T2	—	—	100	—	—	ns	—
S4	CS setup time	T3	—	—	60	—	—	ns	—
S5	CS hold time	T4	—	—	60	—	—	ns	—
S6	CS disable high time	T5	—	—	100	—	—	ns	—
S7	SIN setup time	T6	—	—	50	—	—	ns	—
S8	SIN hold time	T7	—	—	50	—	—	ns	—
S9	SOUT delay time	T8	—	—	—	—	60	ns	—
S10	SOUT hold time	T9	—	—	60	—	—	ns	—
S11	SOUT Enable-Hi-Z time	T10	—	—	—	—	60	ns	—
S12	SOUT Hi-Z-Enable time	T11	—	—	—	—	60	ns	—
S13	SOUT C load	T _{SC}	—	—	—	—	40	pF	—
Digital input / output									
D8	High-level input threshold voltage	V _{in(H)}	—	SCK, SIN, CS, OSCIN, VD_IS, VD_FZ, TEST	—	1.36	—	V	—
D9	Low-level input threshold voltage	V _{in(L)}	—	SCK, SIN, CS, OSCIN, VD_IS, VD_FZ, TEST	—	1.02	—	V	—
D10	RSTB signal pulse width	Trst	—	—	100	—	—	μs	—
D11	Input hysteresis width	V _{hysin}	—	SCK, SIN, CS, OSCIN, VD_IS, VD_FZ, TEST	—	0.34	—	V	—
D12	Video sync. signal width	VD _w	—	—	80	—	—	μs	—
D13	CS signal wait time 1	T _(VD-CS)	—	—	400	—	—	ns	—
D14	CS signal wait time 2	T _(CS-DT1)	—	—	5	—	—	μs	—

2009-10-23		
Established	Revised	

<h1>Product Standards</h1>		<h2>AN41908A</h2>	
		Total Pages	Page
		54	13

■ Electrical Characteristics (Reference values for design) (continued) at
VDD5 = MVCCx = 4.8 V, DVDD = AVDD3 = 3.1 V

Notes) T_a = 25°C±2°C unless otherwise specified.

The characteristics listed below are reference values derived from the design of the IC and are not guaranteed by inspection.
If a problem does occur related to these characteristics, we will respond in good faith to user concerns.

B No.	Parameter	Symbol	Test circuits	Conditions	Reference values			Unit	Notes
					Min	Typ	Max		
Pulse generator									
PL1	Pulse start resolution for pulse 1	PL1wait	—	OSCIN = 27 MHz	—	20.1	—	μs	—
PL2	Pulse resolution for pulse 1	PL1width	—	OSCIN = 27 MHz	—	1.2	—	μs	—
PL3	Pulse start resolution for pulse 2	PL2wait	—	OSCIN = 27 MHz	—	20.1	—	μs	—
Iris control									
IR1	AD sampling frequency	IRIS _{Sample}	—	OSCIN = 27 MHz	—	500	—	kHz	—
Thermal shutdown									
T1	Thermal shutdown operation temperature	T _{tsd}	—	—	—	150	—	°C	—
T2	Thermal shutdown hysteresis width	ΔT _{tsd}	—	—	—	40	—	°C	—
Supply voltage monitor circuit									
R1	3.3 V Reset operation	V _{rston}	—	—	—	2.27	—	V	—
R2	3.3 V Reset hysteresis width	V _{rsthys}	—	—	—	0.2	—	V	—
R3	MVCCx Reset operation	V _{rstFZon}	—	—	—	2.2	—	V	—
R4	MVCCx Reset hysteresis width	V _{rstFZhys}	—	—	—	0.2	—	V	—
R5	VDD5 Reset operation	V _{rstISon}	—	—	—	2.2	—	V	—
R6	VDD5 Reset hysteresis width	V _{rstIShys}	—	—	—	0.2	—	V	—
8 bit DAC for Hall Offset adjustment									
DA1	Adjustment range (High)	DAOTHof	—	—	—	AVDD3	—	V	—
DA2	Adjustment range (Low)	DAOTLof	—	—	—	0	—	V	—
10 bit ADC									
AD1	Input Range (High)	V _{in(H)}	—	—	—	—	AVDD3 - 0.2	V	—
AD2	Input Range (Low)	V _{in(L)}	—	—	0.2	—	—	V	—
AD3	DNLE (Differential linearity error)	DNL10A	—	—	—	1.0	—	LSB	—
AD4	INLE (Integral linearity error)	INL10A	—	—	—	2.0	—	LSB	—

2009-10-23		
Established	Revised	

<h1 style="margin: 0;">Product Standards</h1>		AN41908A	
		Total Pages	Page
		54	14

■ Test Circuit Diagram

1. Test Circuit 1 (Circuit current, Common circuit)

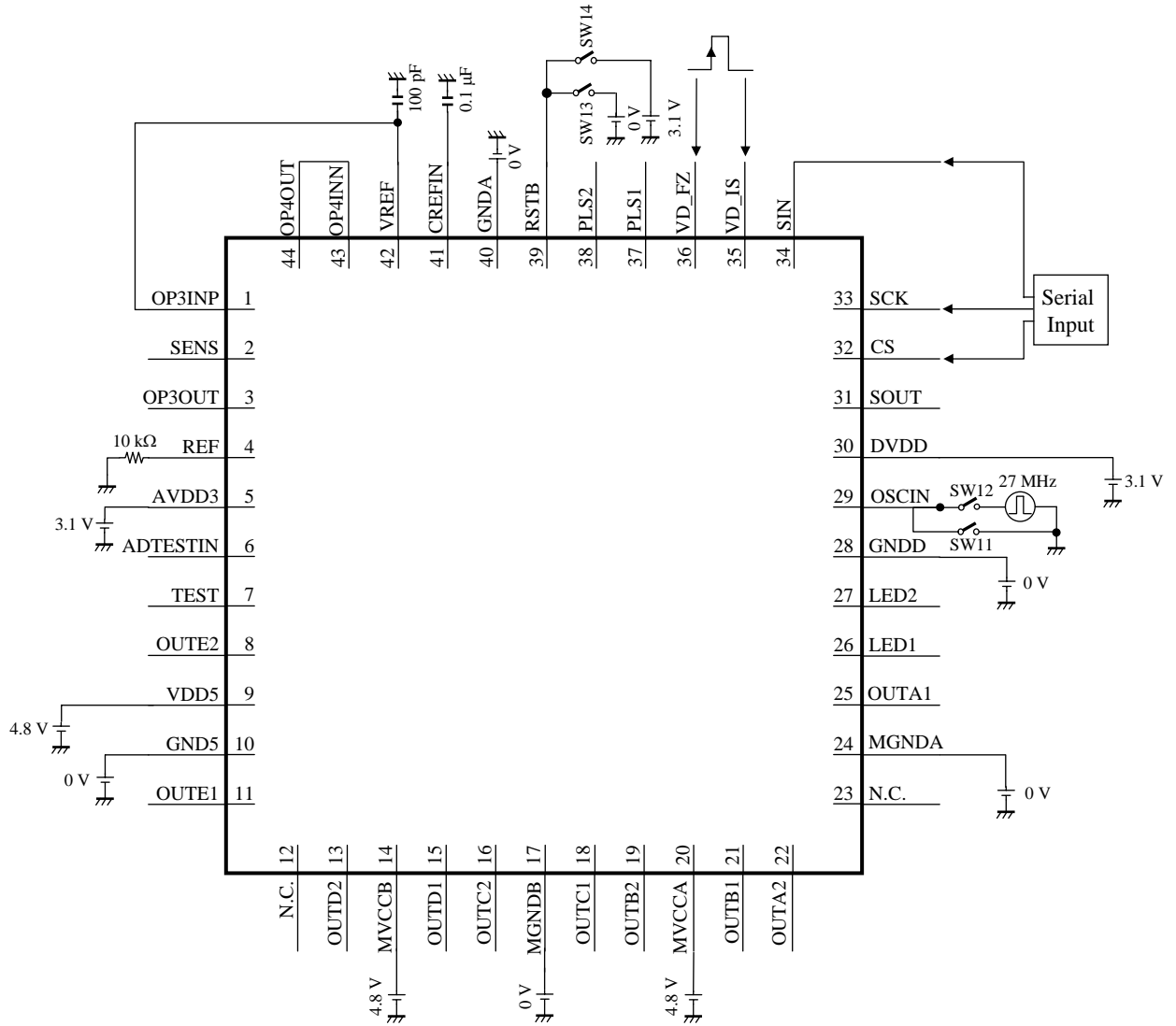

2009-10-23		
Established	Revised	

		AN41908A	
		Product Standards	
		Total Pages	Page
		54	15

■ Test Circuit Diagram (continued)

2. Test Circuit 2 (Digital input / output)

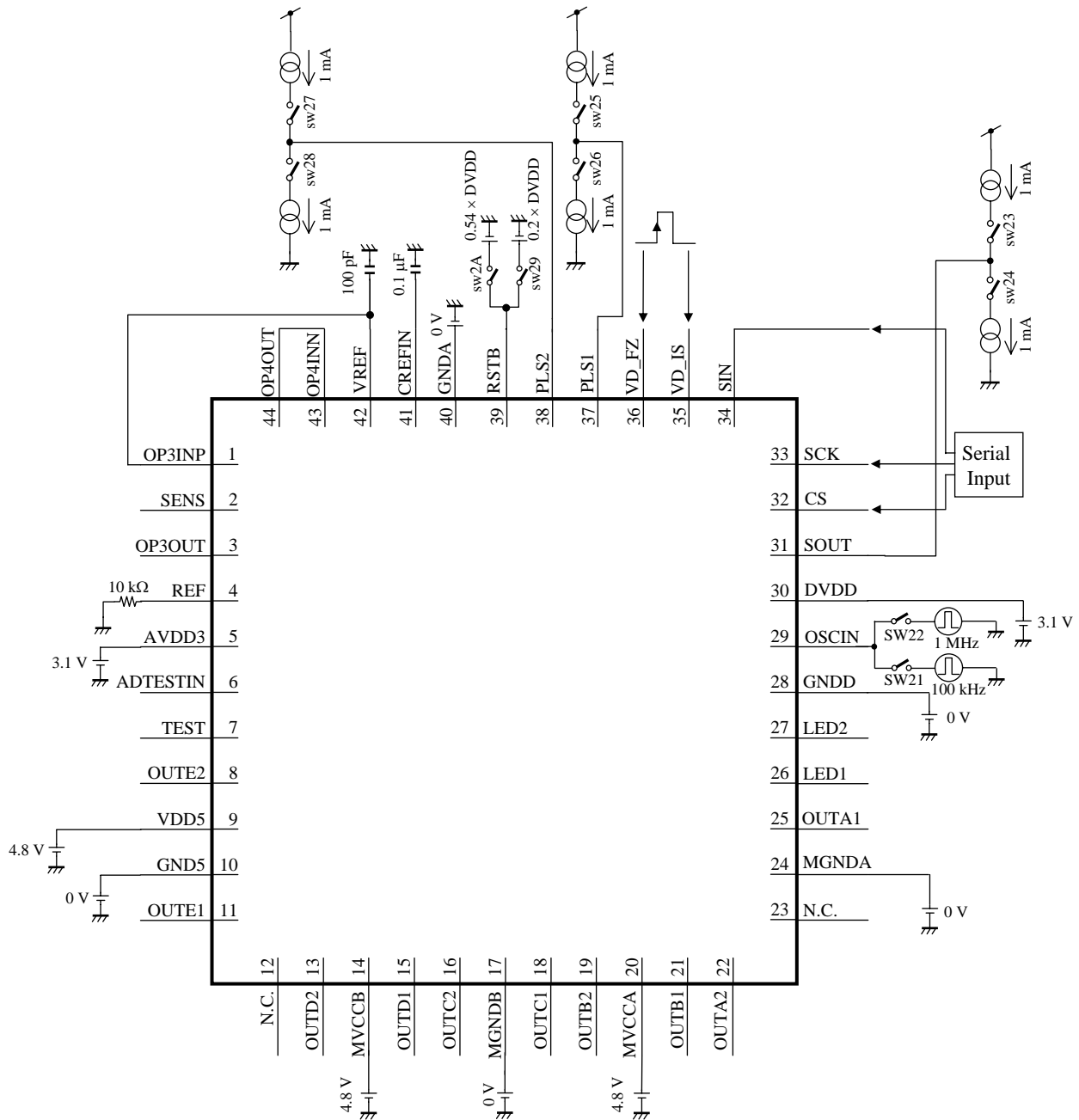

2009-10-23	
Established	Revised

<h1 style="margin: 0;">Product Standards</h1>		AN41908A	
		Total Pages	Page
		54	16

■ Test Circuit Diagram (continued)

3. Test Circuit 3 (Digital input / output : Input pull-down resistance)

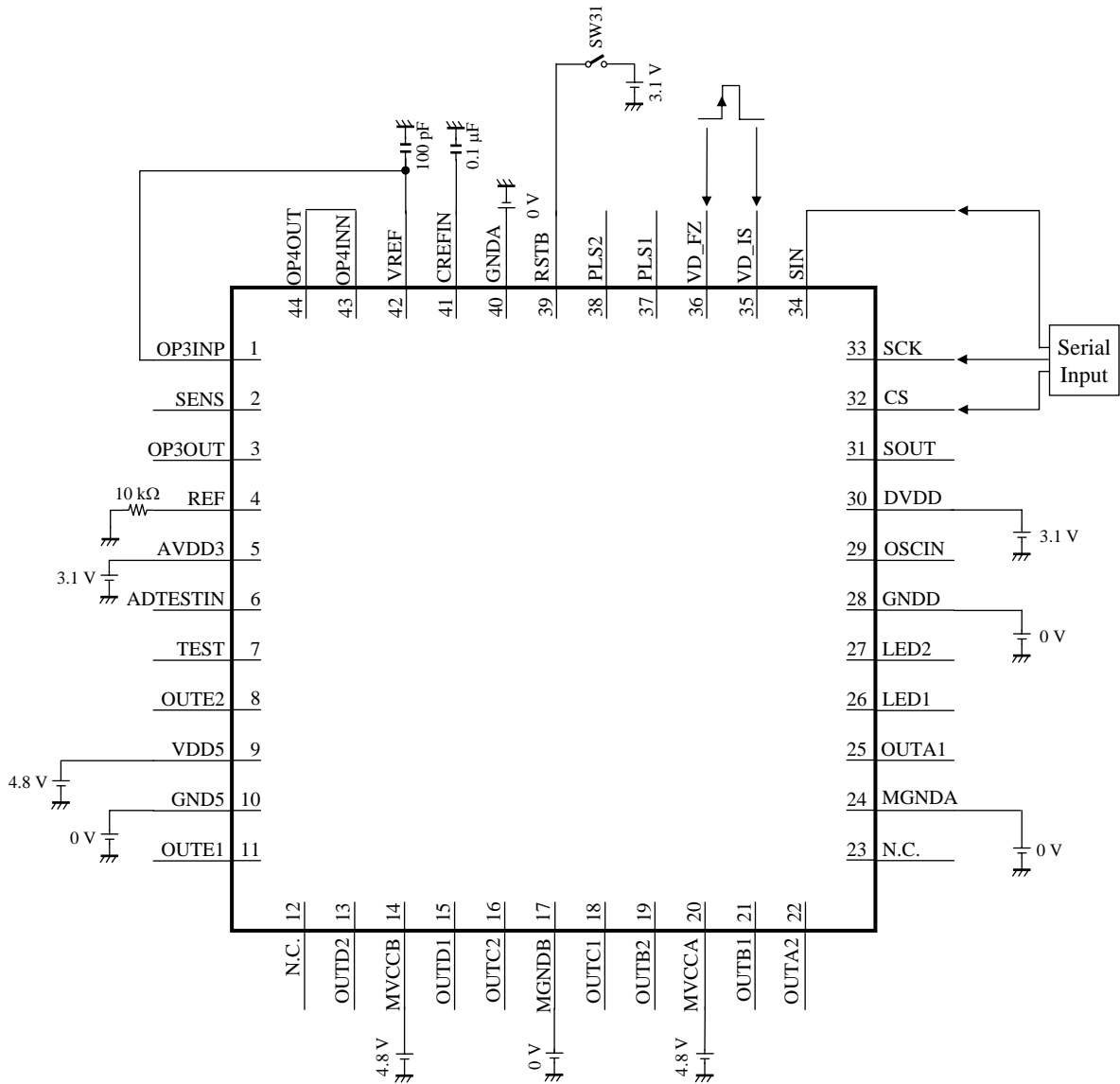

2009-10-23		
Established	Revised	

■ Test Circuit Diagram (continued)

4. Test Circuit 4 (Motor driver : focus, zoom H bridge ON resistance)

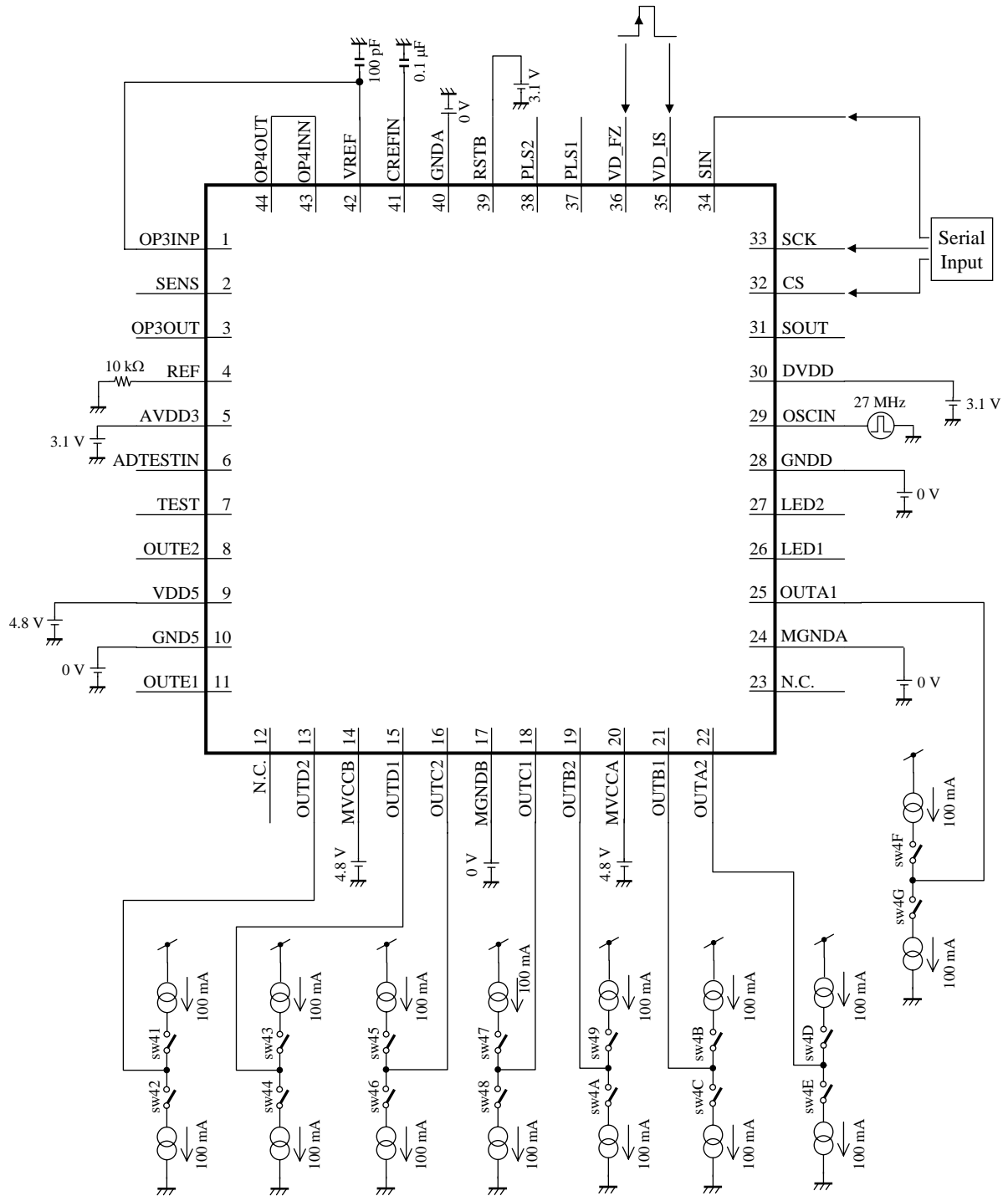

2009-10-23		
Established	Revised	

<h1 style="margin: 0;">Product Standards</h1>		AN41908A	
		Total Pages	Page
		54	18

■ Test Circuit Diagram (continued)

5. Test Circuit 5 (Motor driver : Iris H bridge ON resistance)

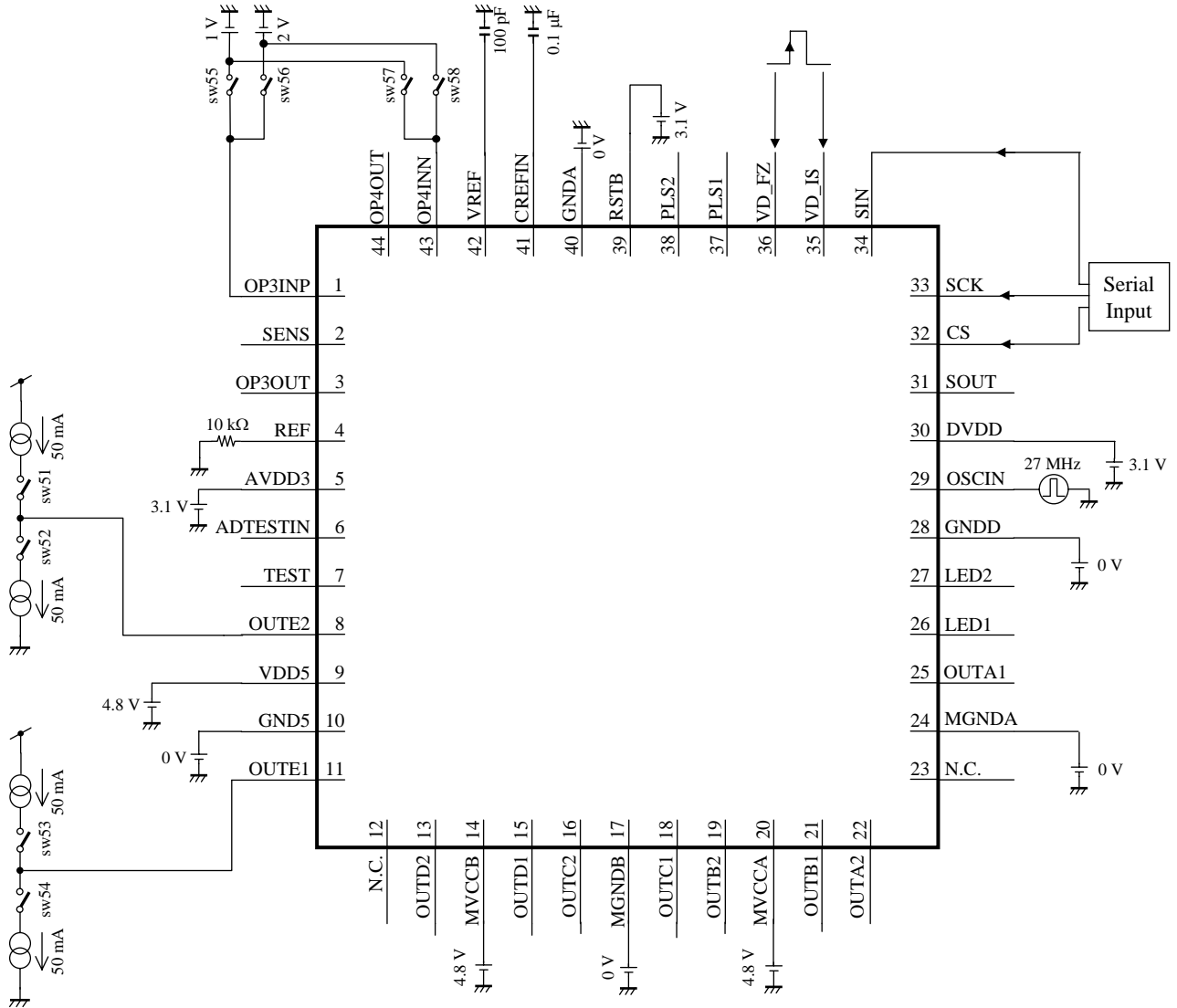

2009-10-23		
Established	Revised	

■ Test Circuit Diagram (continued)

6. Test Circuit 6 (Motor driver : H bridge leak current, LED driver : Output leak current)

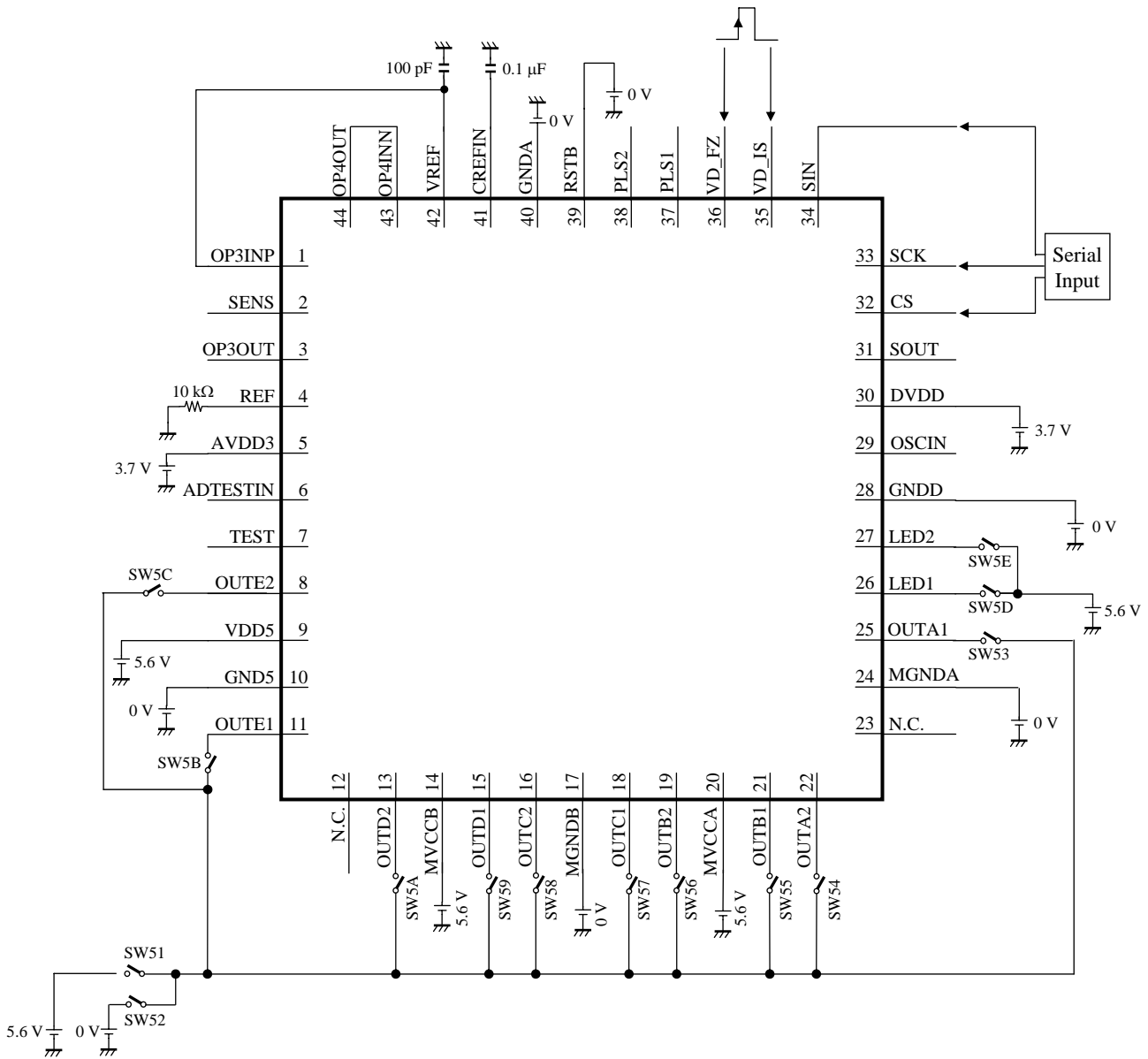

2009-10-23		
Established	Revised	

<h1>Product Standards</h1>		AN41908A	
		Total Pages	Page
		54	20

■ Test Circuit Diagram (continued)

7. Test Circuit 7 (LED driver : Output ON resistance)

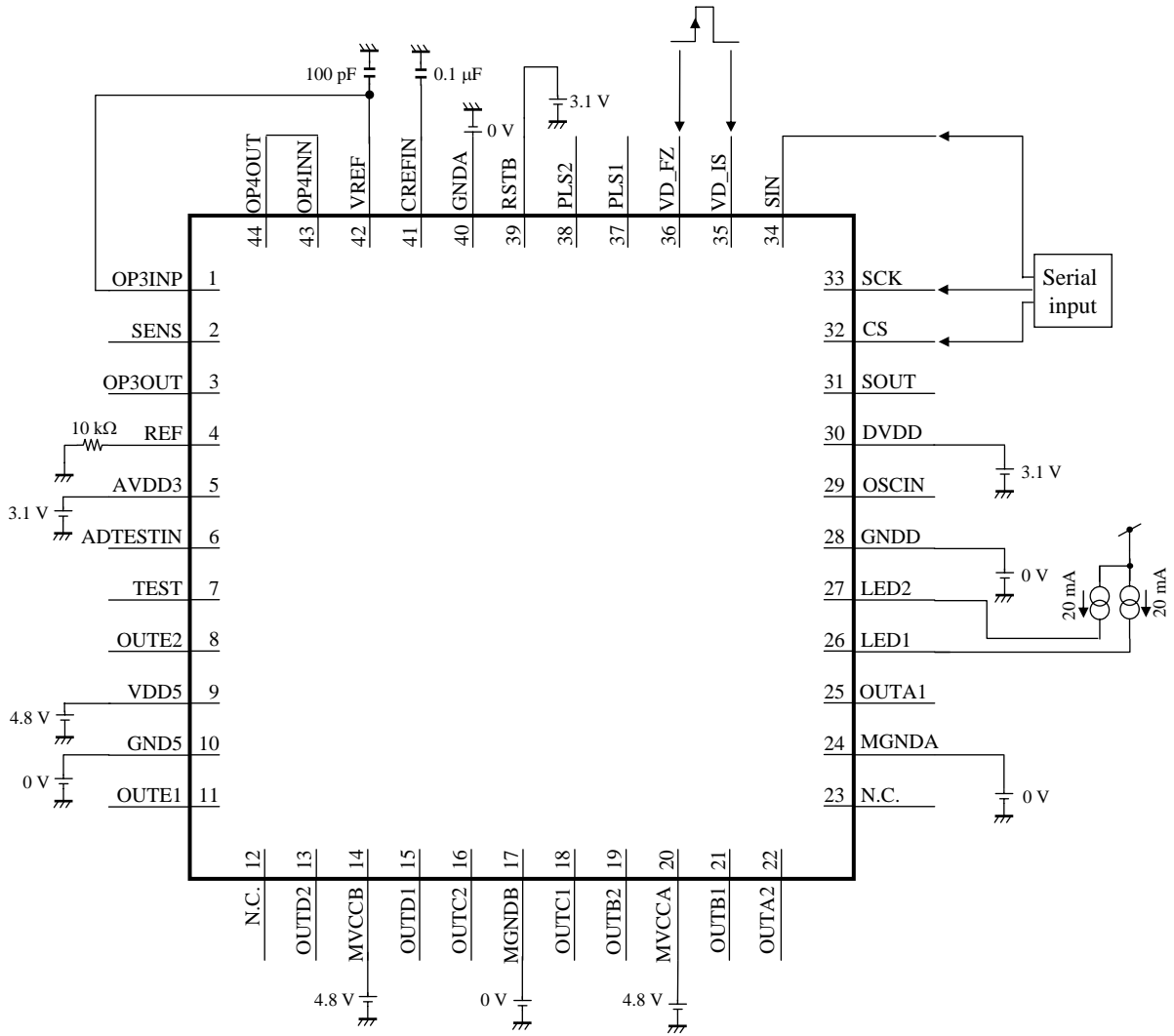

2009-10-23		
Established	Revised	

■ Test Circuit Diagram (continued)
 8. Test Circuit 8 (OPAMP3)

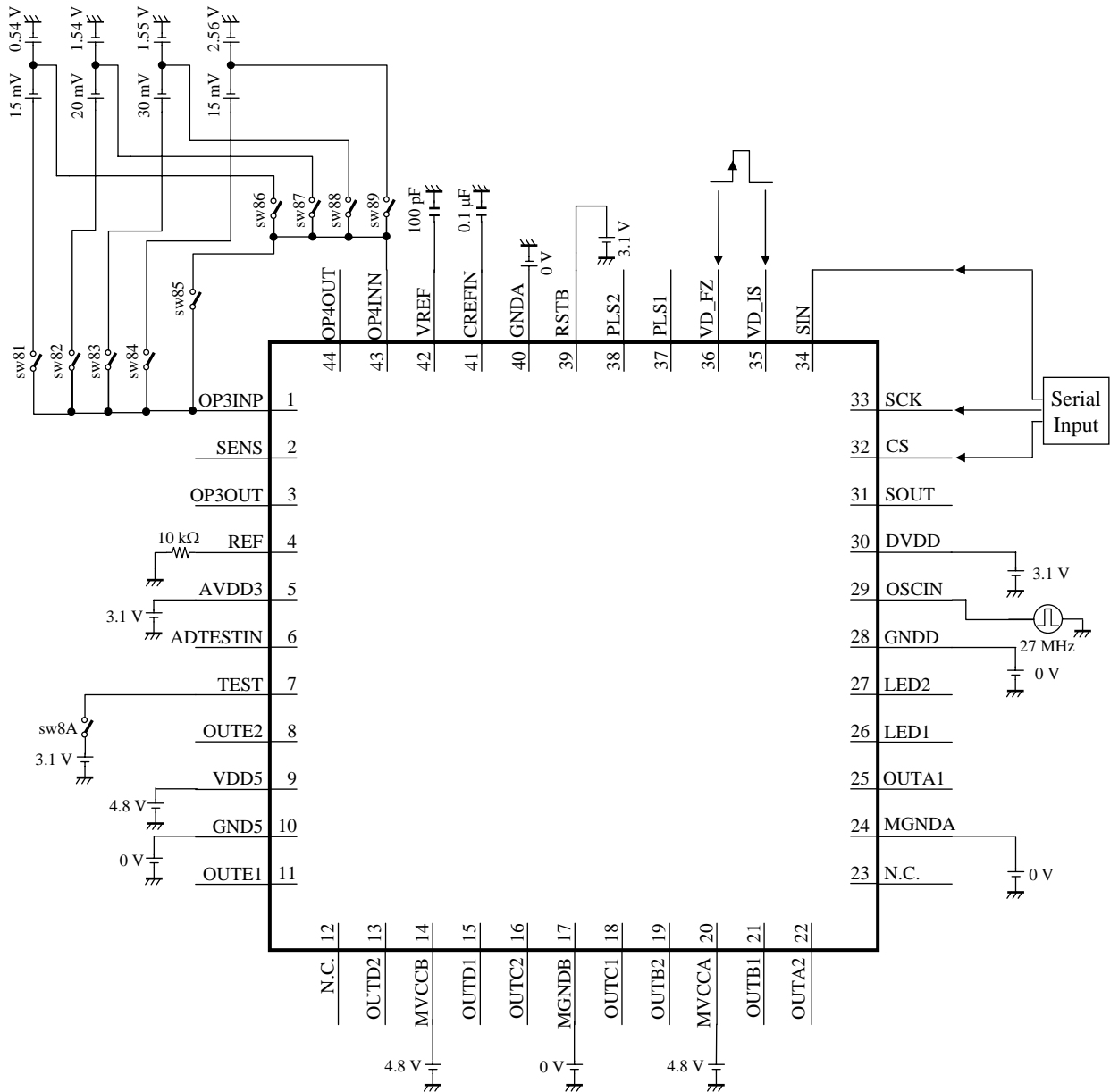

2009-10-23		
Established	Revised	

<h1>Product Standards</h1>		AN41908A	
		Total Pages	Page
		54	22

■ Test Circuit Diagram (continued)

9. Test Circuit 9 (OPAMP3)

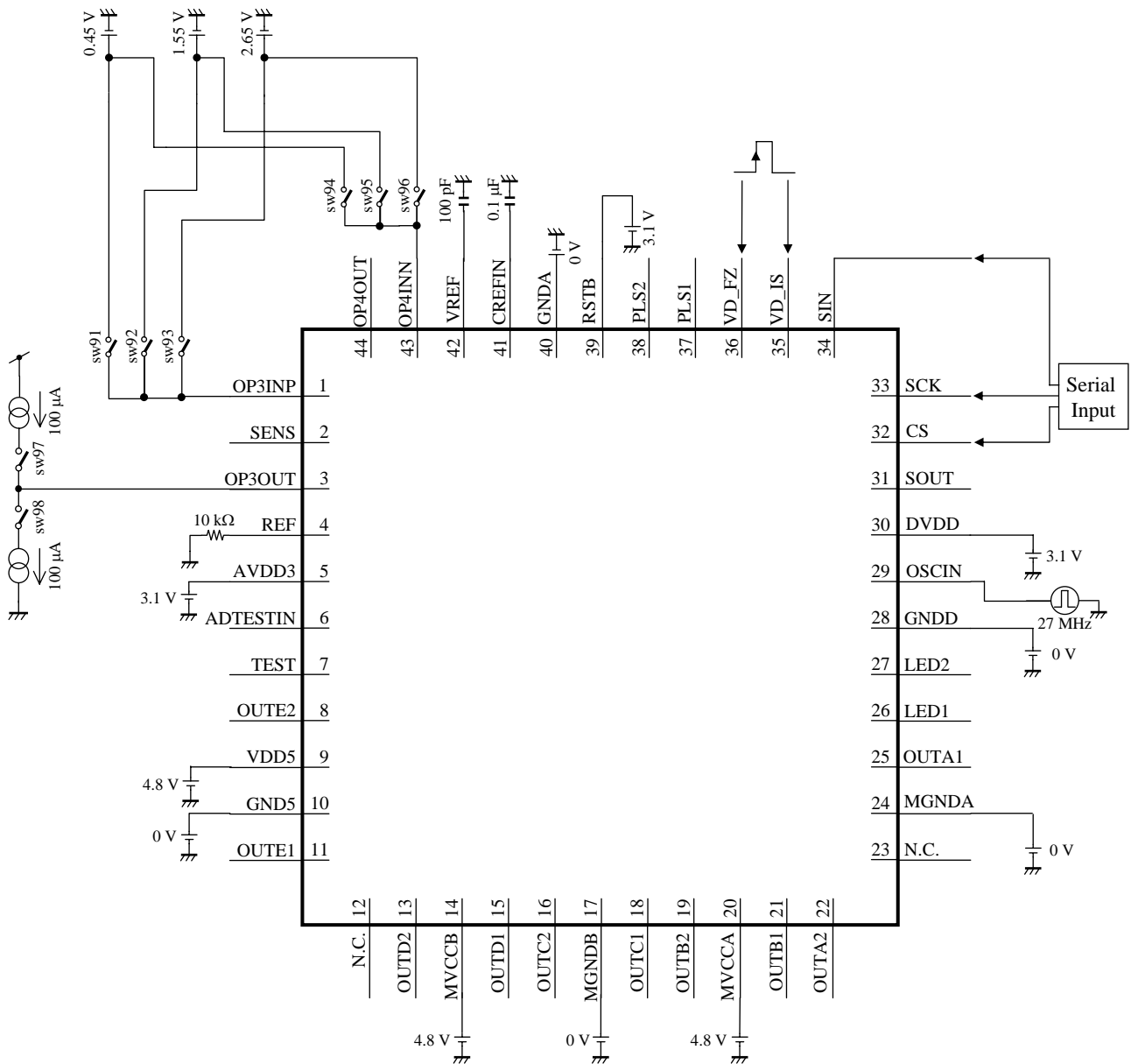

2009-10-23	
Established	Revised

<h1 style="margin: 0;">Product Standards</h1>		AN41908A	
		Total Pages	Page
		54	23

■ Test Circuit Diagram (continued)

10. Test Circuit 10 (OPAMP4, Reference voltage output block, Hall bias controller)

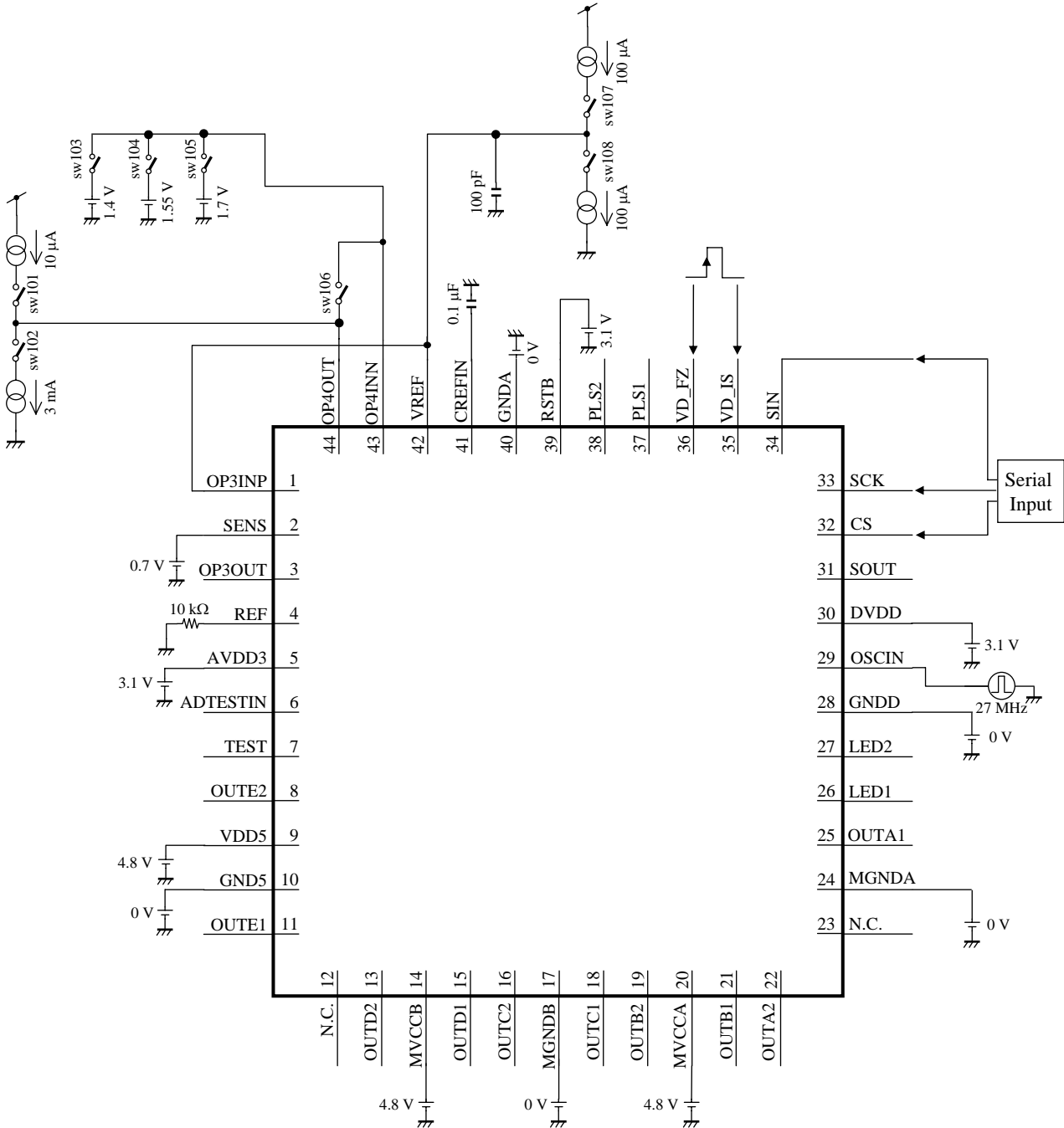

2009-10-23		
Established	Revised	

	<h1>Product Standards</h1>	AN41908A	
		Total Pages	Page
		54	24

■ Electrical Characteristics Test Procedures

C No.	Parameter	Input		Output		Pin settings			
		Pin No.	Conditions	Pin No.	Conditions	SW11	SW12	SW13	SW14
Circuit current, Common circuit									
P1	MVCC supply current on Reset	9 14 20	4.8 V	14 20	Measure the current	ON	OFF	ON	OFF
		5 30	3.1 V						
		7	0 V						
		39	0 V						
P2	MVCC supply current on Enable	9 14 20	4.8 V	14 20	Measure the current	OFF	ON	OFF	ON
		5 30	3.1 V						
		7	0 V						
		39	3.1 V						
		34	*11						
P3	3 V supply current on Reset	9 14 20	4.8 V	5 30	Measure the current	ON	OFF	ON	OFF
		5 30	3.1 V						
		7	0 V						
		39	0 V						
P4	3 V supply current on Enable	9 14 20	4.8 V	5 30	Measure the current	OFF	ON	OFF	ON
		5 30	3.1 V						
		7	0 V						
		39	3.1 V						
		34	*12						

*11 : Serial setting ENDISAB = 1, LEDA = 1, ENDISCD = 1, LEDB = 1

*12 : Serial setting ENDISAB = 1, LEDA = 1, ENDISCD = 1, LEDB = 1, PDWNB=1, HALL_OFFSET_DAC[7:0] = 0Fh

Note) Serial settings are reflected on the rising edge of VD_IS or VD_FZ.

2009-10-23		
Established	Revised	

		<h1>Product Standards</h1>		AN41908A	
				Total Pages	Page
				54	25

■ Electrical Characteristics Test Procedures (continued)

C No.	Parameter	Input		Output		Pin settings			
		Pin No.	Conditions	Pin No.	Conditions	SW11	SW12	SW13	SW14
Circuit current, Common circuit (continued)									
P5	VDD5 supply current on Reset	9 14 20	4.8 V	9	Measure the current	ON	OFF	ON	OFF
		5 30	3.1 V						
		7	0 V						
		39	0 V						
P6	VDD5 supply current on Enable	9 14 20	4.8 V	9	Measure the current	OFF	ON	OFF	ON
		5 30	3.1 V						
		7	0 V						
		39	3.1 V						
		34	*12						
P7	Supply current on Standby	9 14 20	4.8 V	5 9 14 20 30	Measure the current	OFF	ON	OFF	ON
		5 30	3.1 V						
		7	0 V						
		39	3.1 V						
		34	*13						
P8	Supply current when FZ is Enable and Iris is in Power Save mode	9 14 20	4.8 V	5 9 14 20 30	Measure the current	OFF	ON	OFF	ON
		5 30	3.1 V						
		7	0 V						
		39	3.1 V						
		34	*14						

*12 : Serial setting ENDISAB = 1, LEDA = 1, ENDISCD = 1, LEDB = 1, PDWNB = 1, HALL_OFFSET_DAC[7:0] = 0Fh

*13 : Serial setting ENDISAB = 0, LEDA = 0, ENDISCD = 0, LEDB = 0, PDWNB = 0

*14 : Serial setting ENDISAB = 1, ENDISCD = 1

Note) Serial settings are reflected on the rising edge of VD_IS or VD_FZ.

2009-10-23		
Established	Revised	

		<h1>Product Standards</h1>		<h2>AN41908A</h2>			
				Total Pages		Page	
				54		26	

■ Electrical Characteristics Test Procedures (continued)

C No.	Parameter	Input		Output		Pin settings							
		Pin No.	Conditions	Pin No.	Conditions	SW21	SW22	SW23	SW24	SW25 SW27	SW26 SW28	SW29	SW2A
Digital input / output													
D1	High-level input	5 30	3.1 V	41	Measure the voltage (Confirm $1/2 \times$ AVDD3)	ON	OFF	OFF	OFF	OFF	OFF	OFF	ON
		9 14 20	4.8 V										
		39	$0.54 \times$ DVDD										
		29	100 kHz, 0 V / 3.1 V										
		34	*21										
D2	Low-level input	5 30	3.1 V	41	Measure the voltage (Confirm AVDD3)	ON	OFF	OFF	OFF	OFF	OFF	ON	OFF
		9 14 20	4.8 V										
		39	$0.2 \times$ DVDD										
		29	100 kHz, 0 V / 3.1 V										
		34											
D3	SOUT High-level output	5 30	3.1 V	31	Measure the voltage	ON	OFF	OFF	ON	OFF	OFF	OFF	ON
		9 14 20	4.8 V										
		39	3.1 V										
		31	-1 mA										
		29	100 kHz, 0 V / 3.1 V										
		34	*22										
D4	SOUT Low-level output	5 30	3.1 V	31	Measure the voltage	ON	OFF	ON	OFF	OFF	OFF	OFF	ON
		9 14 20	4.8 V										
		39	3.1 V										
		31	1 mA										
		29	100 kHz, 0 V / 3.1 V										
		34	*23										

*21 : Serial setting PDWNB = 1

*22 : Serial setting PPWA[7:0] = FFh, PPWB[7:0] = FFh

*23 : Serial setting PPWA[7:0] = 00h, PPWB[7:0] = 00h

Note) Serial settings are reflected on the rising edge of VD_IS or VD_FZ.

2009-10-23		
Established	Revised	

	<h1>Product Standards</h1>	AN41908A	
		Total Pages	Page
		54	27

■ Electrical Characteristics Test Procedures (continued)

C No.	Parameter	Input		Output		Pin settings					
		Pin No.	Conditions	Pin No.	Conditions	SW21	SW22	SW23	SW24	SW25 SW27	SW26 SW28
Digital input / output (continued)											
D5	PLS1 to 2 High-level output	5 30	3.1 V	38 39	Measure the voltage	OFF	ON	OFF	OFF	OFF	ON
		9 14 20	4.8 V								
		39	3.1 V								
		38	-1 mA								
		39	-1 mA								
		29	1 MHz, 0 V / 3.1 V								
		34	*24								
D6	PLS1 to 2 Low-level output	5 30	3.1 V	38 39	Measure the voltage	OFF	ON	OFF	OFF	ON	OFF
		9 14 20	4.8 V								
		39	3.1 V								
		38	1 mA								
		39	1 mA								
		29	1 MHz, 0 V / 3.1 V								
		34	*25								

*24 : Serial setting TESTEN1 = TESTEN2 = 1, FZTEST[4:0] = 03h, ENDISAB = ENDISCD = 1

*25 : Serial setting TESTEN1 = TESTEN2 = 1, FZTEST[4:0] = 03h, ENDISAB = ENDISCD = 0

Note) Serial settings are reflected on the rising edge of VD_IS or VD_FZ.

2009-10-23		
Established	Revised	

	<h1>Product Standards</h1>	AN41908A	
		Total Pages	Page
		54	28

■ Electrical Characteristics Test Procedures (continued)

C No.	Parameter	Input		Output		Pin settings
		Pin No.	Conditions	Pin No.	Conditions	SW31
Digital input / output (continued)						
D7	Input pull-down resistance	5	3.1 V	39	Measure the current	ON (Pin 39 measurement only)
		9	4.8 V			
		14	4.8 V			
		20	4.8 V			
		30	3.1 V			

2009-10-23		
Established	Revised	

		<h1>Product Standards</h1>		AN41908A			
				Total Pages		Page	
		54		29			

■ Electrical Characteristics Test Procedures (continued)

C No.	Parameter	Input		Output		Pin settings							
		Pin No.	Conditions	Pin No.	Conditions	SW41 SW44	SW42 SW43	SW45 SW48	SW46 SW47	SW49 SW4C	SW4A SW4B	SW4D SW4G	SW4E SW4F
Motor driver													
H1	H bridge ON resistance OUTB (OUTB1_UP + OUTB2_DOWN)	5 30	3.1 V	19 20 21 24	Measure the voltage Ron = {(Pin 20 – Pin 21) + (Pin 19 – Pin 24)} / 100 mA	OFF	OFF	OFF	OFF	ON	OFF	OFF	OFF
		9 14 20	4.8 V										
		39	3.1 V										
		29	27 MHz, 0 V / 3.1 V										
		34	*31										
		19	100 mA										
		21	-100 mA										
H1	H bridge ON resistance OUTD (OUTD1_UP + OUTD2_DOWN)	5 30	3.1 V	13 14 15 17	Measure the voltage Ron = {(Pin 14 – Pin 15) + (Pin 13 – Pin 17)} / 100 mA	ON	OFF	OFF	OFF	OFF	OFF	OFF	OFF
		9 14 20	4.8 V										
		39	3.1 V										
		29	27 MHz, 0 V / 3.1 V										
		13	100 mA										
		15	-100 mA										

*31 : Serial setting
 PDWNB = 1
 TESTEN1 = TESTEN2 = 1,
 DT1[7:0] = DT2A[7:0] = DT2B[7:0] = 01h,
 ENDISAB = ENDISCD = 1,
 SKIPDT1 = SKIPDT2 = 1,
 PWMMODE = [11111], PWMRES = 2h,
 PPWA[7:0] = PPWB[7:0] = PPWC[7:0] = PPWD[7:0] = FFh,
 INTCTAB[15:0] = INTCTCD[15:0] = 0001h

Note) Serial settings are reflected on the rising edge of VD_IS or VD_FZ.

2009-10-23		
Established	Revised	

<h1 style="margin: 0;">Product Standards</h1>		AN41908A	
		Total Pages	Page
		54	30

■ Electrical Characteristics Test Procedures (continued)

C No.	Parameter	Input		Output		Pin settings							
		Pin No.	Conditions	Pin No.	Conditions	SW41 SW44	SW42 SW43	SW45 SW48	SW46 SW47	SW49 SW4C	SW4A SW4B	SW4D SW4G	SW4E SW4F
Motor driver													
H1	H bridge ON resistance OUTA (OUTA1_UP + OUTA2_DOWN)	5 30	3.1 V	20 22 24 25	Measure the voltage Ron = {(Pin 20 – Pin 25) + (Pin 22 – Pin 24)} / 100 mA	OFF	OFF	OFF	OFF	OFF	OFF	ON	OFF
		9 14 20	4.8 V										
		39	3.1 V										
		29	27 MHz, 0 V / 3.1 V										
		34	*32										
		22	100 mA										
		25	–100 mA										
H1	H bridge ON resistance OUTC (OUTC1_UP + OUTC2_DOWN)	5 30	3.1 V	14 16 17 18	Measure the voltage Ron = {(Pin 14 – Pin 18) + (Pin 16 – Pin 17)} / 100 mA	OFF	OFF	ON	OFF	OFF	OFF	OFF	OFF
		9 14 20	4.8 V										
		39	3.1 V										
		29	27 MHz, 0 V / 3.1 V										
		16	100 mA										
		18	–100 mA										

*32 : Serial setting PSUMAB[7:0] = PSUMCD[7:0] = 08h

Note) Serial settings are reflected on the rising edge of VD_IS or VD_FZ.

2009-10-23		
Established	Revised	

		<h1>Product Standards</h1>		AN41908A	
				Total Pages	Page
		54	31		

■ Electrical Characteristics Test Procedures (continued)

C No.	Parameter	Input		Output		Pin settings							
		Pin No.	Conditions	Pin No.	Conditions	SW41 SW44	SW42 SW43	SW45 SW48	SW46 SW47	SW49 SW4C	SW4A SW4B	SW4D SW4G	SW4E SW4F
Motor driver													
H1	H bridge ON resistance OUTB (OUTB2_UP + OUTB1_DOWN)	5 30	3.1 V	19 20 21 24	Measure the voltage Ron = {(Pin 20 – Pin 19) + (Pin 21 – Pin 24)} / 100 mA	OFF	OFF	OFF	OFF	OFF	ON	OFF	OFF
		9 14 20	4.8 V										
		39	3.1 V										
		29	27 MHz, 0 V / 3.1 V										
		36	*33										
		19	–100 mA										
		21	100 mA										
H1	H bridge ON resistance OUTD (OUTD2_UP + OUTD1_DOWN)	5 30	3.1 V	13 14 15 17	Measure the voltage Ron = {(Pin 14 – Pin 13) + (Pin 15 – Pin 17)} / 100 mA	OFF	ON	OFF	OFF	OFF	OFF	OFF	OFF
		9 14 20	4.8 V										
		39	3.1 V										
		29	27 MHz, 0 V / 3.1 V										
		13	–100 mA										
		15	100 mA										

*33 : Impulse input to VD_FZ

2009-10-23		
Established	Revised	

		<h1>Product Standards</h1>		<h2>AN41908A</h2>			
				Total Pages		Page	
				54		32	

■ Electrical Characteristics Test Procedures (continued)

C No.	Parameter	Input		Output		Pin settings							
		Pin No.	Conditions	Pin No.	Conditions	SW41 SW44	SW42 SW43	SW45 SW48	SW46 SW47	SW49 SW4C	SW4A SW4B	SW4D SW4G	SW4E SW4F
Motor driver													
H1	H bridge ON resistance OUTA (OUTA2_UP + OUTA1_DOWN)	5 30	3.1 V	20 22 24 25	Measure the voltage Ron = {(Pin 20 – Pin 22) + (Pin 25 – Pin 24)} / 100 mA	OFF	OFF	OFF	OFF	OFF	OFF	OFF	ON
		9 14 20	4.8 V										
		39	3.1 V										
		29	27 MHz, 0 V / 3.1 V										
		36	*34										
		22	–100 mA										
25	100 mA												
H1	H bridge ON resistance OUTC (OUTC2_UP + OUTC1_DOWN)	5 30	3.1 V	14 16 17 18	Measure the voltage Ron = {(Pin 14 – Pin 16) + (Pin 18 – Pin 17)} / 100 mA	OFF	OFF	OFF	ON	OFF	OFF	OFF	OFF
		9 14 20	4.8 V										
		39	3.1 V										
		29	27 MHz, 0 V / 3.1 V										
		16	–100 mA										
		18	100 mA										

*34 : Impulse input to VD_FZ

2009-10-23		
Established	Revised	

■ Electrical Characteristics Test Procedures (continued)

C No.	Parameter	Input		Output		Pin settings							
		Pin No.	Conditions	Pin No.	Conditions	SW51	SW52	SW53	SW54	SW55	SW56	SW57	SW58
Motor driver													
H3	H bridge ON resistance OUTE (OUTE1_UP + OUTE2_DOWN)	5	3.1 V	8	Measure the voltage Ron = {(Pin 9 – Pin 11) + (Pin 8 – Pin 10)} / 50 mA	ON	OFF	OFF	ON	OFF	ON	ON	OFF
		30											
		9	4.8 V										
		14											
		20											
		39	3.1 V										
		29	27 MHz, 0 V / 3.1 V										
		34	*41										
1	2 V	9	Measure the voltage Ron = {(Pin 9 – Pin 8) + (Pin 11 – Pin 10)} / 50 mA	OFF	ON	ON	OFF	ON	OFF	OFF	OFF	ON	
43	1 V												
8	50 mA												
11	-50 mA												
5	3.1 V												
30													
9	4.8 V												
14													
20													
39	3.1 V												
29	27 MHz, 0 V / 3.1 V												
1	1 V												
43	2 V												
8	-50 mA												
11	50 mA												

*41 : Serial setting PDWNB = 1,
 IRS_TGT[9:0] = 200h, DGAIN[6:0] = 40h,
 PWM_IRIS[2:0] = 7h, HGAIN[3:0] = Fh

Note) Serial settings are reflected on the rising edge of VD_IS or VD_FZ.

2009-10-23		
Established	Revised	

■ Electrical Characteristics Test Procedures (continued)

C No.	Parameter	Input		Output		Pin settings																																																																																	
		Pin No.	Conditions	Pin No.	Conditions	SW 51	SW 52	SW 53	SW 54	SW 55	SW 56	SW 57	SW 58	SW 59	SW 5A	SW 5B	SW 5C																																																																						
Motor driver (continued)																																																																																							
H2	H bridge leak current upper	5	3.7 V	8	Measure the current	OFF	ON	OFF	OFF	OFF	OFF	OFF	OFF	OFF	OFF	OFF	ON																																																																						
				11													OFF	OFF	OFF	OFF	OFF	OFF	OFF	OFF	OFF	OFF	OFF																																																												
		9	5.6 V	13													Measure the current	OFF	ON	OFF	OFF	OFF	OFF	OFF	OFF	OFF	OFF	OFF	OFF	ON																																																									
				15																										OFF	OFF	OFF	OFF	OFF	OFF	OFF	OFF	OFF	OFF	OFF																																															
		14 20	5.6 V	16																										Measure the current	OFF	ON	OFF	OFF	OFF	OFF	OFF	OFF	OFF	OFF	OFF	OFF	OFF	OFF																																											
				18																																								OFF	OFF	OFF	OFF	OFF	OFF	OFF	OFF	OFF	OFF	OFF	OFF																																
		30	3.7 V	19																																								Measure the current	OFF	ON	OFF	OFF	OFF	OFF	OFF	OFF	OFF	OFF	OFF	OFF	OFF	OFF																													
				21																																																						OFF	OFF	OFF	OFF	OFF	OFF	OFF	OFF	OFF	OFF	OFF	OFF																		
		39	0 V	22																																																						Measure the current	OFF	ON	OFF	OFF	OFF	OFF	OFF	OFF	OFF	OFF	OFF	OFF	OFF	OFF															
				25																																																																				OFF	OFF	OFF	OFF	OFF	OFF	OFF	OFF	OFF	OFF	OFF	OFF				
		H2	H bridge leak current lower	5																																																																				3.7 V	8	Measure the current	ON	OFF	OFF	OFF	OFF	OFF	OFF	OFF	OFF	OFF	OFF	ON	
																																																																									11													OFF	OFF
9	5.6 V			13	Measure the current	ON	OFF	OFF	OFF	OFF	OFF	OFF	OFF	OFF	OFF	OFF																																																								OFF	OFF													ON	
				15																																																																																		OFF	OFF
14 20	5.6 V			16													Measure the current	ON	OFF	OFF	OFF	OFF	OFF	OFF	OFF	OFF	OFF	OFF	OFF																																																									OFF	OFF
				18																																																																																			OFF
30	3.7 V			19																										Measure the current	ON	OFF	OFF	OFF	OFF	OFF	OFF	OFF	OFF	OFF	OFF	OFF	OFF																																												OFF
				21																																																																																			OFF
39	0 V			22																																								Measure the current	ON	OFF	OFF	OFF	OFF	OFF	OFF	OFF	OFF	OFF	OFF	OFF	OFF																														OFF
				25																																																																																			OFF

2009-10-23		
Established	Revised	

	<h1>Product Standards</h1>	AN41908A	
		Total Pages	Page
		54	35

■ Electrical Characteristics Test Procedures (continued)

C No.	Parameter	Input		Output		Pin settings	
		Pin No.	Conditions	Pin No.	Conditions	SW5D	SW5E
LED driver							
L2	LED output leak current	26 27	5.6 V	26	Measure the current	ON	OFF
				27		OFF	ON
L1	Output ON resistance	26 27	20 mA	26 27	After measuring the voltage of each pin, calculate the below ; LED1 : (Pin 26 – Pin 24) / 20 mA LED2 : (Pin 27 – Pin 24) / 20 mA	—	—
		34					

2009-10-23		
Established	Revised	

■ Electrical Characteristics Test Procedures (continued)

C No.	Parameter	Input		Output		Pin settings									
		Pin No.	Conditions	Pin No.	Conditions	SW 81	SW 82	SW 83	SW 84	SW 85	SW 86	SW 87	SW 88	SW 89	SW 8A
OPAMP3 (Hall Sensor Amp. for output amplifier)															
O1	Input voltage range Low	5 30 39	3.1 V	3	Measure the voltage ; Vo1 : Output voltage when inputting 0.54 V to Pin 1 and Pin 43 Vo2 : Output voltage when inputting 0.555 V to Pin 1, 0.54 V to Pin 43 Calculation (Vo1 – 0.54) × 0.015 / (Vo2 – Vo1) Confirm that the calculational result is within input offset rating.	OFF	OFF	OFF	OFF	ON	ON	OFF	OFF	OFF	ON
		9 14 20	4.8 V												
		7	3.1 V												
		34	*51												
		1 43	0.54 V												
		1	0.555 V												
O1	Input voltage range High	5 30 39	3.1 V	3	Measure the voltage ; Vo1 : Output voltage when inputting 2.56 V to Pin 1 and Pin 43 Vo2 : Output voltage when inputting 2.575 V to Pin 1, 2.56 V to Pin 43 Calculation (Vo1 – 2.56) × 0.015 / (Vo2 – Vo1) Confirm that the calculational result is within input offset rating.	OFF	OFF	OFF	OFF	ON	OFF	OFF	OFF	ON	ON
		9 14 20	4.8 V												
		7	3.1 V												
		34	*51												
		1 43	2.56 V												
		1	2.575 V												
O2	Input offset voltage	5 30 39	3.1 V	3	Measure the voltage Vo1 : Output voltage when inputting 1.55 V to Pin 1 and Pin 43 Vo2 : Output voltage when inputting 1.58 V to Pin 1, 1.55 V to Pin 43 Calculation (Vo1 – 1.55) × 0.03 / (Vo2 – Vo1)	OFF	OFF	OFF	OFF	ON	OFF	OFF	ON	OFF	ON
		9 14 20	4.8 V												
		7	3.1 V												
		34	*51												
		1 43	1.55 V												
		1	1.58 V												

*51 : Serial setting PDWNB = 1, HALL_GAIN[3:0] = 0

Note) Serial settings are reflected on the rising edge of VD_IS or VD_FZ.

2009-10-23		
Established	Revised	

■ Electrical Characteristics Test Procedures (continued)

C No.	Parameter	Input		Output		Pin settings							
		Pin No.	Conditions	Pin No.	Conditions	SW91	SW92	SW93	SW94	SW95	SW96	SW97	SW98
OPAMP3 (Hall Sensor Amp. for output amplifier) (continued)													
O3	Output voltage Low	5 30 39	3.1 V	3	Measure the voltage	OFF	ON	OFF	OFF	OFF	ON	ON	OFF
		9 14 20	4.8 V										
		1	1.55 V										
		43	2.65 V										
		34	*52										
		3	100 μA										
O3	Output voltage Low	5 30 39	3.1 V	3	Measure the voltage	ON	OFF	OFF	OFF	ON	OFF	ON	OFF
		9 14 20	4.8 V										
		1	0.45 V										
		43	1.55 V										
		34	*52										
		3	100 μA										
O4	Output voltage High	5 30 39	3.1 V	3	Measure the voltage	OFF	OFF	ON	OFF	ON	OFF	OFF	ON
		9 14 20	4.8 V										
		1	2.65 V										
		43	1.55 V										
		34	*52										
		3	-100 μA										
O4	Output voltage High	5 30 39	3.1 V	3	Measure the voltage	OFF	ON	OFF	ON	OFF	OFF	OFF	ON
		9 14 20	4.8 V										
		1	1.55 V										
		43	0.45 V										
		34	*52										
		3	-100 μA										

*52 : Serial setting PDWNB = 1, HALL_GAIN[3:0] = 0, HALL_OFFSET_DAC[7:0] = 0Fh

Note) Serial settings are reflected on the rising edge of VD_IS or VD_FZ.

2009-10-23		
Established	Revised	

	<h1>Product Standards</h1>	<h2>AN41908A</h2>	
		Total Pages	Page
		54	38

■ Electrical Characteristics Test Procedures (continued)

C No.	Parameter	Input		Output		Pin settings									
		Pin No.	Conditions	Pin No.	Conditions	SW 81	SW 82	SW 83	SW 84	SW 85	SW 86	SW 87	SW 88	SW 89	SW 8A
OPAMP3 (Hall Sensor Amp. for output amplifier) (continued)															
O5	Gain	5 30 39	3.1 V	3	Measure the voltage Vo1 : Output voltage when inputting 1.54 V to Pin 1 and Pin 43 Vo2 : Output voltage when inputting 1.56 V to Pin 1, 1.54 V to Pin 43 Calculation (Vo2 – Vo1)/0.02										
		9 14 20	4.8 V			OFF	OFF	OFF	OFF	ON	OFF	ON	OFF	OFF	OFF
		34	*53												
		1 43	1.54 V												
		1	1.56 V			OFF	ON	OFF	OFF	OFF	OFF	OFF	OFF	OFF	OFF

*53 : Serial setting PDWNB = 1, HALL_GAIN[3:0] = 0h, HALL_OFFSET_DAC[7:0] = 0Fh

Note) Serial settings are reflected on the rising edge of VD_IS or VD_FZ.

2009-10-23		
Established	Revised	

	<h1>Product Standards</h1>	<h2>AN41908A</h2>	
		Total Pages	Page
		54	39

■ Electrical Characteristics Test Procedures (continued)

C No.	Parameter	Input		Output		Pin settings							
		Pin No.	Conditions	Pin No.	Conditions	SW 101	SW 102	SW 103	SW 104	SW 105	SW 106	SW 107	SW 108
OPAMP4 (Hall Sensor Amp. for eliminating common-mode voltage)													
O6 O8	Input voltage range Output voltage Low OP4INN = High	5 30 39	3.1 V	44	Measure the voltage	OFF	ON	OFF	OFF	ON	OFF	OFF	OFF
		9 14 20	4.8 V										
		43	1.7 V										
		44	10 μA										
		34	*61										
O6 O9	Input voltage range Output voltage High OP4INN = Low	5 30 39	3.1 V	44	Measure the voltage	ON	OFF	ON	OFF	OFF	OFF	OFF	OFF
		9 14 20	4.8 V										
		43	1.40 V										
		44	-3 mA										
		34	*61										
O7	Input offset voltage	5 30 39	3.1 V	42 44	Measure the voltage OP4OUT, VREF Calculation OP4OUT - VREF	OFF	OFF	OFF	OFF	OFF	ON	OFF	OFF
		9 14 20	4.8 V										
		34	*61										

*61 : Serial setting PDWNB = 1

2009-10-23		
Established	Revised	

	<h1>Product Standards</h1>	AN41908A	
		Total Pages	Page
		54	40

■ Electrical Characteristics Test Procedures (continued)

C No.	Parameter	Input		Output		Pin settings							
		Pin No.	Conditions	Pin No.	Conditions	SW 101	SW 102	SW 103	SW 104	SW 105	SW 106	SW 107	SW 108
Reference voltage output block													
O10	Output voltage 1	5 30 39	3.1 V	42	Measure the voltage	OFF	OFF	OFF	OFF	OFF	OFF	OFF	OFF
		9 14 20	4.8 V										
		34	*61										
O11	Output voltage 2 (-100 μA)	5 30 39	3.1 V	42	Measure the voltage	OFF	OFF	OFF	OFF	OFF	OFF	OFF	ON
		9 14 20	4.8 V										
		34	*61										
		42	-100 μA										
O11	Output voltage 2 (100 μA)	5 30 39	3.1 V	42	Measure the voltage	OFF	OFF	OFF	OFF	OFF	OFF	OFF	ON
		9 14 20	4.8 V										
		34	*61										
		42	100 μA										

*61 : Serial setting PDWNB = 1

2009-10-23		
Established	Revised	

		Product Standards				AN41908A			
						Total Pages		Page	
		54		41					

■ Electrical Characteristics Test Procedures (continued)

C No.	Parameter	Input		Output		Pin settings							
		Pin No.	Conditions	Pin No.	Conditions	SW 101	SW 102	SW 103	SW 104	SW 105	SW 106	SW 107	SW 108
Hall bias controller (SENS pin output)													
O12	Min. output current	5 30 39	3.1 V	2	Measure the current	OFF	OFF	OFF	OFF	OFF	OFF	OFF	OFF
		9 14 20	4.8 V										
		34	*71										
		2	0.7 V										
O13	Output current accuracy 1	5 30 39	3.1 V	2	Measure the current	OFF	OFF	OFF	OFF	OFF	OFF	OFF	OFF
		9 14 20	4.8 V										
		34	*72										
		2	0.7 V										
O14	Output current accuracy 2	5 30 39	3.1 V	2	Measure the current	OFF	OFF	OFF	OFF	OFF	OFF	OFF	OFF
		9 14 20	4.8 V										
		34	*73										
		2	0.7 V										

*71 : Serial setting PDWNB = 1, HALL_BIAS_DAC[7:0] = 00h

*72 : Serial setting PDWNB = 1, HALL_BIAS_DAC[7:0] = 40h

*73 : Serial setting PDWNB = 1, HALL_BIAS_DAC[7:0] = BEh

Note) Serial settings are reflected on the rising edge of VD_IS or VD_FZ.

2009-10-23		
Established	Revised	

<h1>Product Standards</h1>		AN41908A	
		Total Pages	Page
		54	42

■ Technical Data

- I/O block circuit diagrams and pin function descriptions

Note) The characteristics listed below are reference values derived from the design of the IC and are not guaranteed.

Pin No.	Waveform and voltage	Internal circuit	Impedance	Description
1	—		—	OP3INP Hall signal amplifier non-inverting input pin
2	—		—	SENS Hall current bias output pin
3	Hall signal amplifier output		—	OP3OUT Hall amp. output pin
4	—		—	REF Resistor pin for Hall bias

2009-10-23		
Established	Revised	

<h1>Product Standards</h1>		AN41908A	
		Total Pages	Page
		54	43

■ Technical Data (continued)

- I/O block circuit diagrams and pin function descriptions (continued)

Note) The characteristics listed below are reference values derived from the design of the IC and are not guaranteed.

Pin No.	Waveform and voltage	Internal circuit	Impedance	Description
5	AVDD3		—	AVDD3 3 V analog power supply pin
6	—		—	ADTESTIN ADC test input pin
7	GNDD to DVDD Logic signal input		10 kΩ	TEST Test mode input pin TEST
8	—		—	OUTE2 Iris output pin 0

2009-10-23		
Established	Revised	

	<h1>Product Standards</h1>	AN41908A	
		Total Pages	Page
		54	44

■ Technical Data (continued)

- I/O block circuit diagrams and pin function descriptions (continued)

Note) The characteristics listed below are reference values derived from the design of the IC and are not guaranteed.

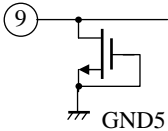
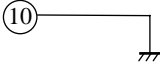
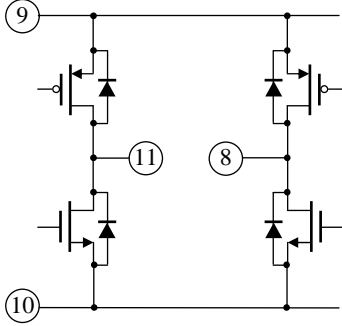
Pin No.	Waveform and voltage	Internal circuit	Impedance	Description
9	VDD5		—	VDD5 5 V power supply pin
10	GND5		—	GND5 5V GND pin
11	—		—	OUTE1 Iris output pin 1
12	—	—	—	N.C.

2009-10-23		
Established	Revised	

	<h1>Product Standards</h1>	<h2>AN41908A</h2>	
		Total Pages	Page
		54	45

■ Technical Data (continued)

- I/O block circuit diagrams and pin function descriptions (continued)

Note) The characteristics listed below are reference values derived from the design of the IC and are not guaranteed.

Pin No.	Waveform and voltage	Internal circuit	Impedance	Description
13	—	<p>The diagram shows a half-bridge circuit. Node 14 is at the top, node 17 is at the bottom, and node 13 is the output node between two transistors. The left transistor has its emitter at node 17 and its collector at node 13. The right transistor has its emitter at node 13 and its collector at node 14.</p>	—	OUTD2 Motor output pin D2
14	MVCCB	—	—	MVCCB Power supply pin for motor B
15	—	<p>The diagram shows a half-bridge circuit. Node 14 is at the top, node 17 is at the bottom, and node 15 is the output node between two transistors. The left transistor has its emitter at node 17 and its collector at node 15. The right transistor has its emitter at node 15 and its collector at node 14.</p>	—	OUTD1 Motor output pin D1
16	—	<p>The diagram shows a half-bridge circuit. Node 14 is at the top, node 17 is at the bottom, and node 16 is the output node between two transistors. The left transistor has its emitter at node 17 and its collector at node 16. The right transistor has its emitter at node 16 and its collector at node 14.</p>	—	OUTC2 Motor output pin C2

2009-10-23		
Established	Revised	

	<h1>Product Standards</h1>	<h2>AN41908A</h2>	
		Total Pages	Page
		54	46

■ Technical Data (continued)

- I/O block circuit diagrams and pin function descriptions (continued)

Note) The characteristics listed below are reference values derived from the design of the IC and are not guaranteed.

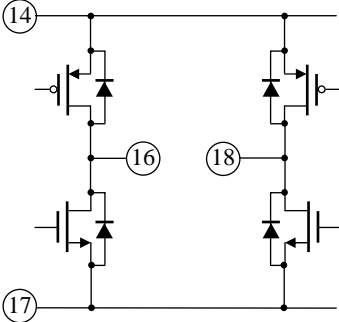
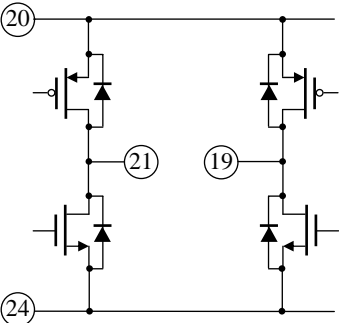
Pin No.	Waveform and voltage	Internal circuit	Impedance	Description
17	MGNDB		—	MGNDB GND pin for motor B
18	—		—	OUTC1 Motor output pin C1
19	—		—	OUTB2 Motor output pin B2
20	—	—	—	MVCCA Power supply pin for motor A

2009-10-23		
Established	Revised	

	<h1>Product Standards</h1>	AN41908A	
		Total Pages	Page
		54	47

■ Technical Data (continued)

- I/O block circuit diagrams and pin function descriptions (continued)

Note) The characteristics listed below are reference values derived from the design of the IC and are not guaranteed.

Pin No.	Waveform and voltage	Internal circuit	Impedance	Description
21	—		—	OUTB1 Motor output pin B1
22	—		—	OUTA2 Motor output pin A2
23	—	—	—	N.C.
24	MGNDA		—	MGNDA GND pin for motor A

2009-10-23		
Established	Revised	

<h1 style="margin: 0;">Product Standards</h1>		AN41908A	
		Total Pages	Page
		54	48

■ Technical Data (continued)

- I/O block circuit diagrams and pin function descriptions (continued)

Note) The characteristics listed below are reference values derived from the design of the IC and are not guaranteed.

Pin No.	Waveform and voltage	Internal circuit	Impedance	Description
25	—		—	OUTA1 Motor output pin A1
26	Hi-Z or open-drain output		Serial selection Hi-Z Max. 8 Ω	LED1 Open-drain 1 for driving LED
27	Hi-Z or open-drain output		Serial selection Hi-Z Max. 8 Ω	LED2 Open-drain 2 for driving LED
28	GNDD		—	GNDD Digital GND pin

2009-10-23		
Established	Revised	

	<h1>Product Standards</h1>	<h2>AN41908A</h2>	
		Total Pages	Page
		54	49

■ Technical Data (continued)

- I/O block circuit diagrams and pin function descriptions (continued)

Note) The characteristics listed below are reference values derived from the design of the IC and are not guaranteed.

Pin No.	Waveform and voltage	Internal circuit	Impedance	Description
29	GNDD to DVDD logic signal input		Hi-Z	OSCIN OSCIN input pin (Schmidt)
30	DVDD		—	DVDD 3 V digital power supply pin
31	GNDD to DVDD logic signal output / Hi-Z		—	SOUT Serial data output pin
32	GNDD to DVDD logic signal input		Hi-Z	CS Chip select signal input pin (Schmidt)

2009-10-23		
Established	Revised	

<h1 style="margin: 0;">Product Standards</h1>		AN41908A	
		Total Pages	Page
		54	50

■ Technical Data (continued)

- I/O block circuit diagrams and pin function descriptions (continued)

Note) The characteristics listed below are reference values derived from the design of the IC and are not guaranteed.

Pin No.	Waveform and voltage	Internal circuit	Impedance	Description
33	GNDD to DVDD logic signal input		Hi-Z	SCK Serial clock input pin (Schmidt)
34	GNDD to DVDD logic signal input		Hi-Z	SIN Serial data input pin (Schmidt)
35	GNDD to DVDD logic signal input		Hi-Z	VD_IS VD_IS input pin (Schmidt)
36	GNDD to DVDD logic signal input		Hi-Z	VD_FZ VD_FZ input pin (Schmidt)

2009-10-23		
Established	Revised	

<h1>Product Standards</h1>		AN41908A	
		Total Pages	Page
		54	51

■ Technical Data (continued)

- I/O block circuit diagrams and pin function descriptions (continued)

Note) The characteristics listed below are reference values derived from the design of the IC and are not guaranteed.

Pin No.	Waveform and voltage	Internal circuit	Impedance	Description
37	GNDD to DVDD logic signal output		—	PLS1 Pulse 1 output pin
38	GNDD to DVDD logic signal output		—	PLS2 Pulse 2 output pin
39	Logic signal input		100 kΩ	RSTB Reset signal input pin
40	GNDA		—	GNDA 3 V analog GND

2009-10-23		
Established	Revised	

<h1 style="margin: 0;">Product Standards</h1>		AN41908A	
		Total Pages	Page
		54	52

■ Technical Data (continued)

- I/O block circuit diagrams and pin function descriptions (continued)

Note) The characteristics listed below are reference values derived from the design of the IC and are not guaranteed.

Pin No.	Waveform and voltage	Internal circuit	Impedance	Description
41	—		25 kΩ	CREFIN (AVDD3)/2 capacitor connection pin
42	—		—	VREF Reference voltage for Hall sensor
43	—		—	OP4INN Midpoint bias amplifier non-inverting input pin
44	—		—	OP4OUT Midpoint bias amplifier output pin

2009-10-23		
Established	Revised	

	<h1>Product Standards</h1>	<h2>AN41908A</h2>	
		Total Pages	Page
		54	53

■ Usage Notes

• Special attention and precaution in using

1. This IC is intended to be used for general electronic equipment [camcorder].
Consult our sales staff in advance for information on the following applications:
 - Special applications in which exceptional quality and reliability are required, or if the failure or malfunction of this IC may directly jeopardize life or harm the human body.
 - Any applications other than the standard applications intended.
 - (1) Space appliance (such as artificial satellite, and rocket)
 - (2) Traffic control equipment (such as for automobile, airplane, train, and ship)
 - (3) Medical equipment for life support
 - (4) Submarine transponder
 - (5) Control equipment for power plant
 - (6) Disaster prevention and security device
 - (7) Weapon
 - (8) Others : Applications of which reliability equivalent to (1) to (7) is required
2. Pay attention to the direction of LSI. When mounting it in the wrong direction onto the PCB (printed-circuit-board), it might smoke or ignite.
3. Pay attention in the PCB (printed-circuit-board) pattern layout in order to prevent damage due to short circuit between pins. In addition, refer to the Pin Description for the pin configuration.
4. Perform a visual inspection on the PCB before applying power, otherwise damage might happen due to problems such as a solder-bridge between the pins of the semiconductor device. Also, perform a full technical verification on the assembly quality, because the same damage possibly can happen due to conductive substances, such as solder ball, that adhere to the LSI during transportation.
5. Take notice in the use of this product that it might break or occasionally smoke when an abnormal state occurs such as output pin- V_{CC} short (Power supply fault), output pin-GND short (Ground fault), or output-to-output-pin short (load short) .
And, safety measures such as an installation of fuses are recommended because the extent of the above-mentioned damage and smoke emission will depend on the current capability of the power supply.
6. When designing your equipment, comply with the range of absolute maximum rating and the guaranteed operating conditions (operating power supply voltage and operating environment etc.). Especially, please be careful not to exceed the range of absolute maximum rating on the transient state, such as power-on, power-off and mode-switching. Otherwise, we will not be liable for any defect which may arise later in your equipment.
Even when the products are used within the guaranteed values, take into the consideration of incidence of break down and failure mode, possible to occur to semiconductor products. Measures on the systems such as redundant design, arresting the spread of fire or preventing glitch are recommended in order to prevent physical injury, fire, social damages, for example, by using the products.
7. When using the LSI for new models, verify the safety including the long-term reliability for each product.
8. When the application system is designed by using this LSI, be sure to confirm notes in this book.
Be sure to read the notes to descriptions and the usage notes in the book.
9. Take time to check the characteristics on use. When changing an external circuit constant for use, consider not only static characteristics, but also transient characteristics and external parts with respect to the characteristics difference among ICs so that you can get enough margin. Moreover, consider the influence of electric charge remaining in an external capacitor on rising/falling of power supply.

2009-10-23		
Established	Revised	

	<h1>Product Standards</h1>	<h2>AN41908A</h2>	
		Total Pages	Page
		54	54

■ Usage Notes (continued)

• Notes of Power LSI

1. The protection circuit is for maintaining safety against abnormal operation. Therefore, the protection circuit should not work during normal operation.
Especially for the thermal protection circuit, if the area of safe operation or the absolute maximum rating is momentarily exceeded due to output pin to V_{CC} short (Power supply fault), or output pin to GND short (Ground fault), the LSI might be damaged before the thermal protection circuit could operate.
2. Unless specified in the product specifications, make sure that negative voltage or excessive voltage are not applied to the pins because the device might be damaged, which could happen due to negative voltage or excessive voltage generated during the ON and OFF timing when the inductive load of a motor coil or actuator coils of optical pick-up is being driven.
3. The product which has specified ASO (Area of Safe Operation) should be operated in ASO.
4. Verify the risks which might be caused by the malfunctions of external components.
5. Apply voltage from a low-impedance to power supply pins and connect a bypass capacitor to the LSI as near as possible.

2009-10-23		
Established	Revised	

Regulations No.	SC3S1962	Total pages	Page
		6	1

Package Standards

Package Code	*QFN044-P-0606D
--------------	-----------------

Semiconductor Company
Panasonic Corporation

Established by	Applied by	Checked by	Prepared by
H.Shidooka	H.Yoshida	M.Okajima	M.Itoh

-	-
Established	Revised

Established: 2009-06-01
Revised : 2009-06-17

		<h1>Package Standards</h1>	
		6	2

1. Outline Drawing

Unit:mm

Package Code : *QFN044-P-0606D

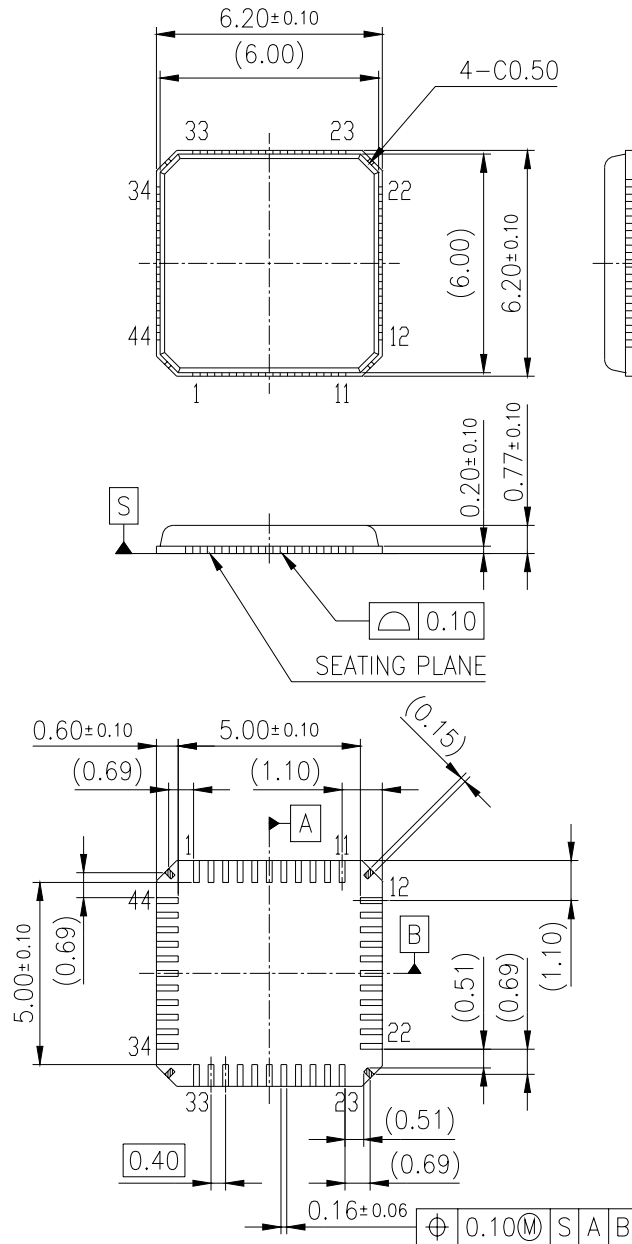

Body Material	: Br / Sb Free Epoxy Resin
Lead Material	: Cu Alloy
Lead Finish Method	: Pd Plating

-	-	
Established	Revised	

	<h1>Package Standards</h1>		
		Total pages	Page
		6	3

2. Package Structure (Technical Report : Reference Value)

Package Code : *QFN044-P-0606D

Chip Material	Si	①	
Leadframe material	Cu alloy	②	
Inner lead surface	Pd plating	③	
Outer lead surface	Pd plating	④	
Die attach	Method	Resin adhesive method	⑤
	Material	Adhesive material	
Wirebond	Method	Thermo-compression bonding	⑥
	Material	Au	
Molding	Method	Transfer molding	⑦
	Material	Br/Sb Free Epoxy resin	
Mass	67 mg		

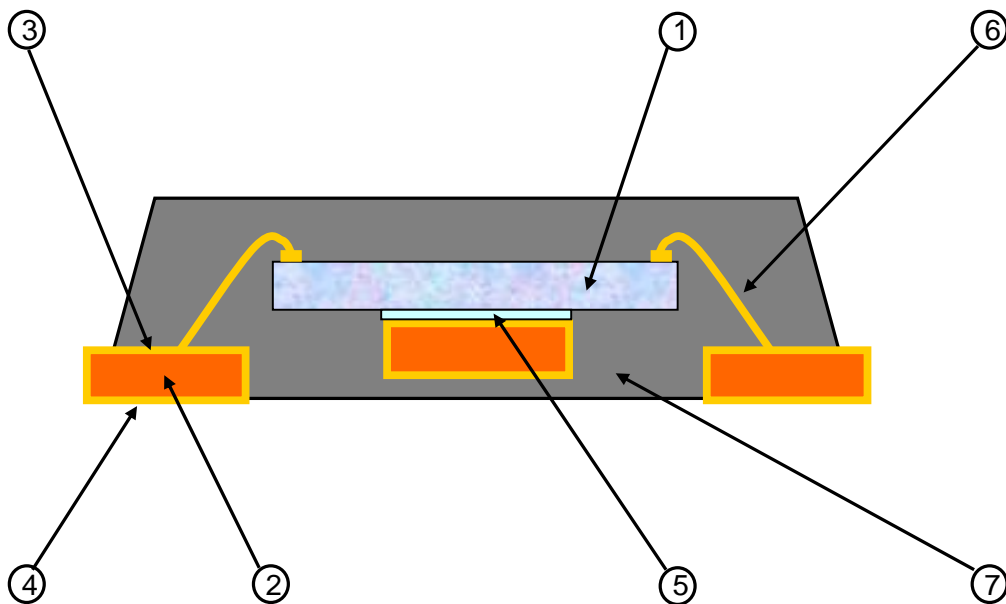

-	-	
Established	Revised	

	<h1>Package Standards</h1>		
		Total pages	Page
		6	4

3. Mark Layout

Package Code : *QFN044-P-0606D

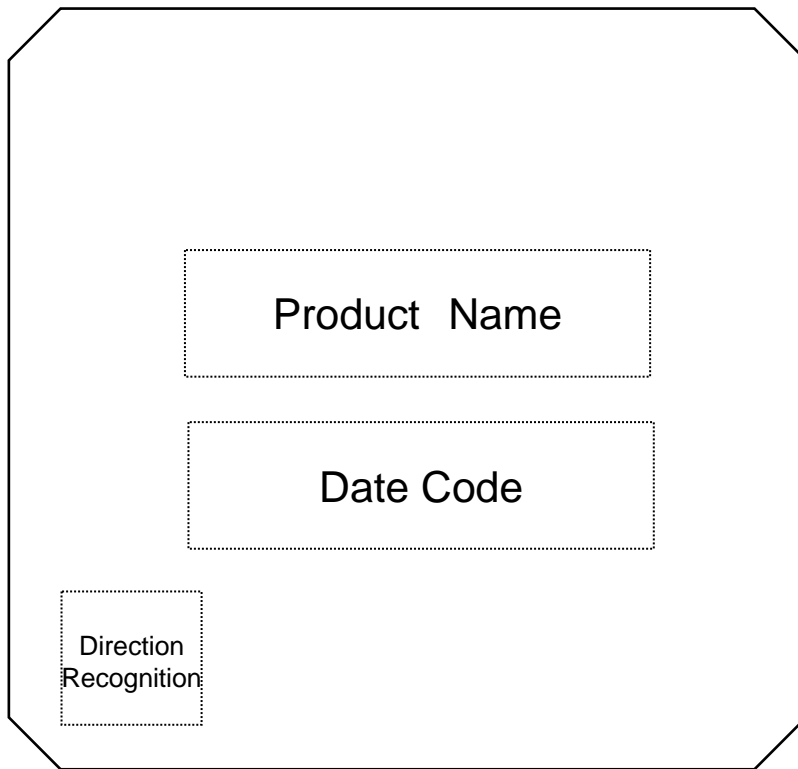

-	-	
Established	Revised	

	<h1>Package Standards</h1>		
		Total pages	Page
		6	5

4. Power Dissipation (Technical Report)

Package Code : *QFN044-P-0606D

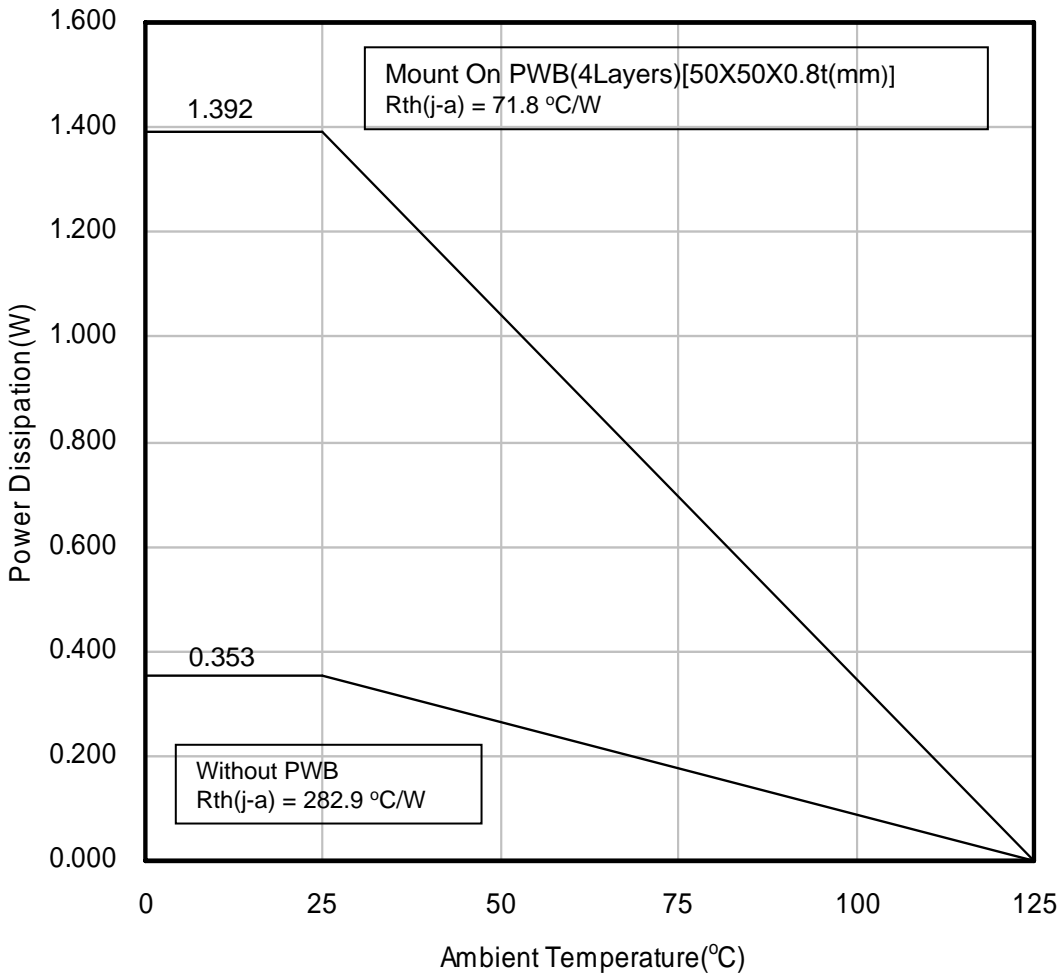

-	-	
Established	Revised	

Established: 2009-06-01
 Revised : 2009-06-17

<h1>Package Standards</h1>			
		Total pages	Page
		6	6

5. Power Dissipation (Supplementary Explanation)

[Experiment environment]

Power Dissipation (Technical Report) is a result in the experiment environment of SEMI standard conformity. (Ambient air temperature (Ta) is 25 degrees C)

[Supplementary information of PWB to be used for measurement]

The supplement of PWB information for Power Dissipation data (Technical Report) are shown below.

Indication	Total Layer	Resin Material
Glass-Epoxy	1-layer	FR-4
4-layer	4-layer	FR-4

[Notes about Power Dissipation (Thermal Resistance)]

Power Dissipation values (Thermal Resistance) depend on the conditions of the surroundings, such as specification of PWB and a mounting condition , and a ambient temperature. (Power Dissipation (Thermal Resistance) is not a fixed value.)

The Power Dissipation value (Technical Report) is the experiment result in specific conditions (evaluation environment of SEMI standard conformity) ,and keep in mind that Power Dissipation values (Thermal resistance) depend on circumference conditions and also change.

[Definition of each temperature and thermal resistance]

Ta : Ambient air temperature

The temperature of the air is defined at the position where the convection, radiation, etc. don't affect the temperature value, and it's separated from the heating elements.

Tc : It's the temperature near the center of a package surface. The package surface is defined at the opposite side if the PWB.

Tj : Semiconductor element surface temperature (Junction temperature.)

Rth(j-c) : The thermal resistance (difference of temperature of per 1 Watts) between a semiconductor element junction part and the package surface

Rth(c-a) : The thermal resistance (difference of temperature of per 1 Watts) between the package surface and the ambient air

Rth(j-a) : The thermal resistance (difference of temperature of per 1 Watts) between a semiconductor element junction part and the ambient air

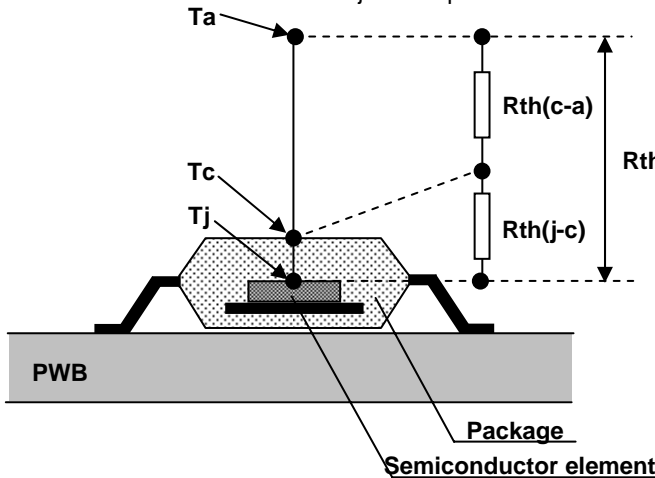

Fig1. Definition image

[Definition formula]

$$T_j = \{R_{th}(j-c) + R_{th}(c-a)\} \times P + T_a$$

$$= R_{th}(j-a) \times P + T_a$$

$$R_{th}(j-c) = \frac{T_j - T_c}{P} \quad (\text{ } / \text{W})$$

$$R_{th}(c-a) = \frac{T_c - T_a}{P} \quad (\text{ } / \text{W})$$

$$R_{th}(j-a) = \frac{T_j - T_a}{P} \quad (\text{ } / \text{W})$$

$$= R_{th}(j-c) + R_{th}(c-a)$$

P:power(W)

-	-	
Established	Revised	

	Recommended Soldering Conditions		
		Total pages	page
		2	1

Product name : AN41908A-VB

Package : *QFN044-P-0606D

1. Recommended Soldering Conditions

In case that the semiconductor packages are mounted on the PCB, the soldering should be performed under the following conditions.

① Reflow soldering

Reflow peak temp. : max. 260 °C

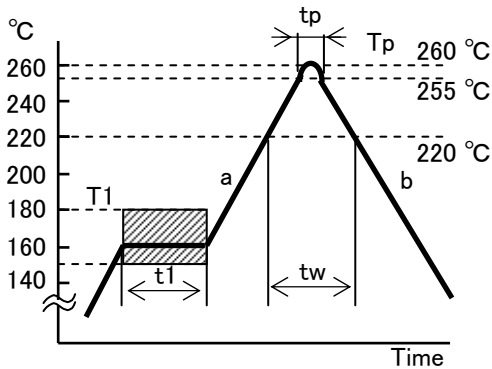

No.	mark	contents	value
1	T1	Pre-heating temp.	150 °C~180 °C
2	t1	Pre-heating temp. hold time	60 s~120 s
3	a	Rising rate	2 °C/s~5 °C/s
4	Tp	Peak temp.	255 °C+5 °C, -0 °C
5	tp	Peak temp. hold time	10 s±3 s
6	tw	High temp. region hold time	within 60 s (≥220 °C)
7	b	Down rate	2 °C/s~5 °C/s
8	-	Number of reflow	within 2 times

* Peak temperature : less than 260 °C

* Temperature is measured at package surface point

No. 11-181

2012/3/7		
Prepared	Revised	

	Recommended Soldering Conditions		Total pages	page
			2	2

2. Storage environment after dry pack opening

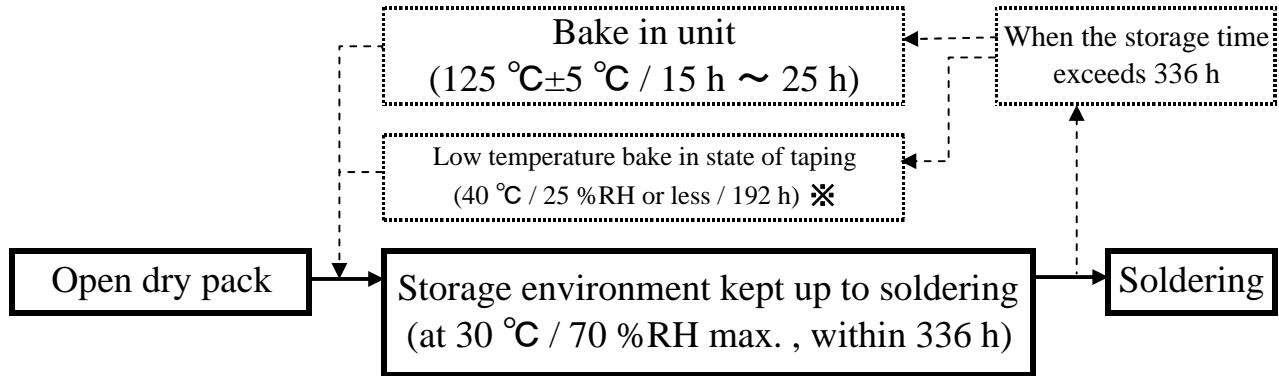

- ✘ Because the taping and the magazine materials are not the heat-resistant materials, the bake at 125°C cannot be done.
Therefore, please solder everything or control everything in the rule time.
Please keep them in an equal environment with the moisture-proof packaging or dry box.
(Temperature: room temperature, relative humidity: 30% or less.)
To control storage time, when bake in the taping and the magazine is necessary, it is necessary for each type to set a bake condition. Please inquire of our company.

☆ AN41908A-VB limitation, low temperature bake condition : 40 °C / 25 %RH or less / 192 h

3. Note

- ① Storage environment conditions: keep the following conditions Ta=5 °C~30 °C, RH=30 %~70 %.
- ② Storage period before opening dry pack shall be 1year from a shipping day under Ta=5 °C~30 °C, RH=30 %~70 %.
- ③ Baking cycle should be only one time. Please be cautious of solderability at baking.
- ④ Reflow soldering : max. two times. (1st reflow must be finished within 336 hours.)
- ⑤ Remove flux sufficiently from product in the washing process.
(Flux : Chlorineless rosin flux is recommended.)
- ⑥ In case that use ultrasonic for product washing,
There is the possibility that the resonance may occur due to the frequency and shape of PCB.
It may be affected to the strength of lead. Please be cautious of this matter.

No. 11-181

2012.3.7		
Prepared	Revised	

2012.03.09	
Prepared	Revised

Referential PCB & Mask spec. for QFN

Application Specific Standard Products BU
Semiconductor Company
Panasonic Corporation

Reference

【Expansion of part A】

(Reference figure) Package Code : QFN044-P-0606 (0.40mmP/44pin, 6.2mm□)

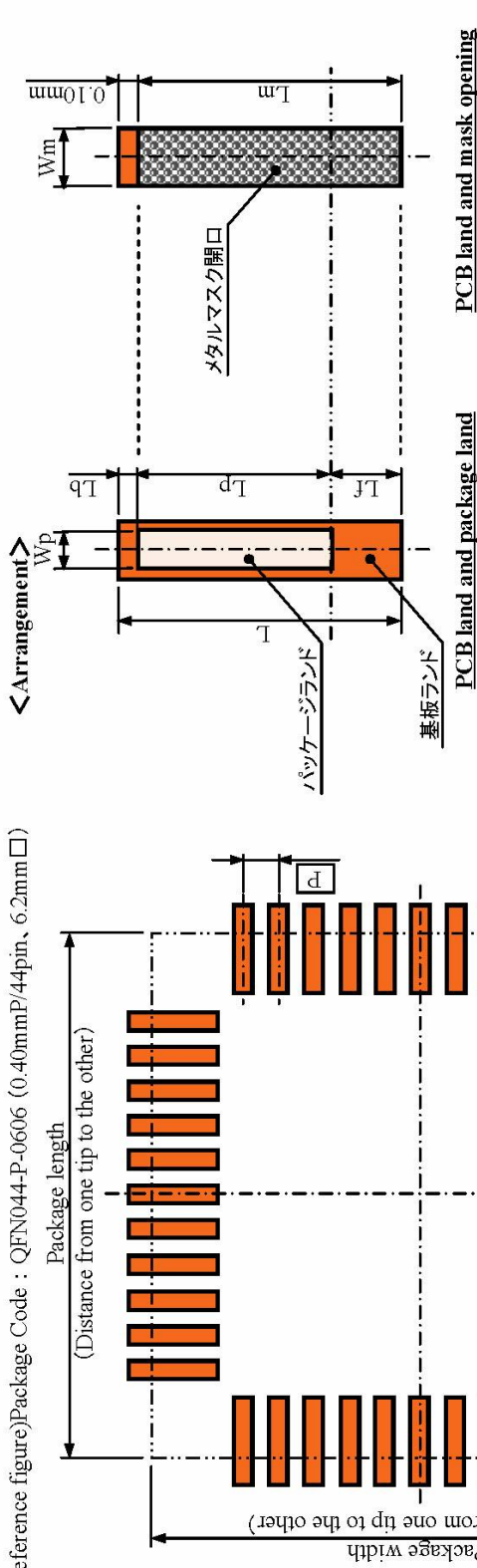

【Cross-sectional figure of PCB land】

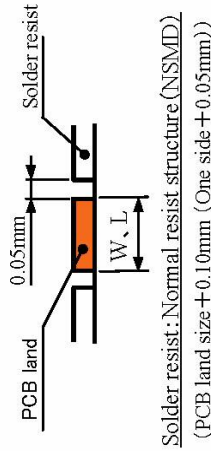

*Stencil mask thickness : 0.11 ~ 0.13mm

■ Recommended PCB & Stencil mask design size (Unit: mm)

Terminal pitch P	Package land		PCB Land		Metal Mask Opening	
	Width Wp	Length Lp	Width W	Length L	Width Wm	Length Lm
0.40mmP	0.16	0.60	0.20	1.00	0.20	0.90
0.50mmP	0.20	0.60	0.25	1.00	0.25	0.90

*The above size is calculated based on the experiment results by Panasonic Corporation and is not intended as a guarantee of mounting reliability. Mounting reliability can vary depending on factors such as the equipment specifications and conditions, material specifications and properties, and environmental conditions. To ensure satisfactory results, your company should evaluate and confirm actual mounting performance.

Panasonic ideas for life

Recommended Land Pattern

Total pages	page
1	1

	<h1>Packing Specification</h1>		
		Total pages	page
		3	1

Specifications of packing by the embossment tape
 (Specifications for dampproof packing of the reel without the inner carton)

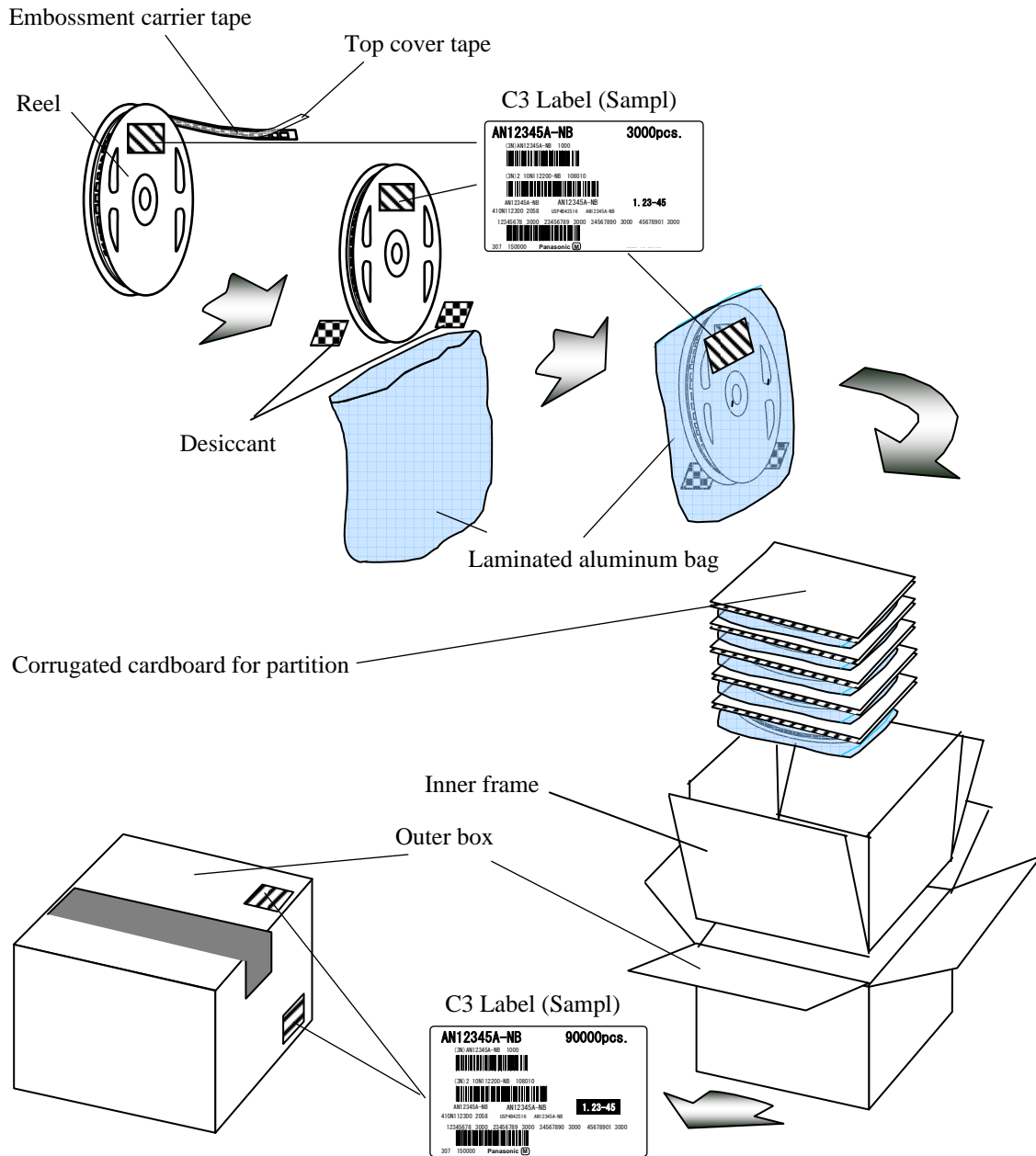

2009.05.29		
Prepared	Revised	

	<h1>Packing Specification</h1>	Total pages	page
		3	2

Package : *QFN044-P-0606D

Unit : mm

1 Packing

1) Tape

V B

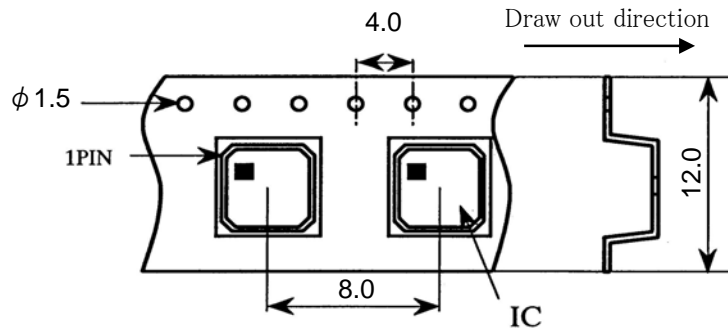

2) Reel

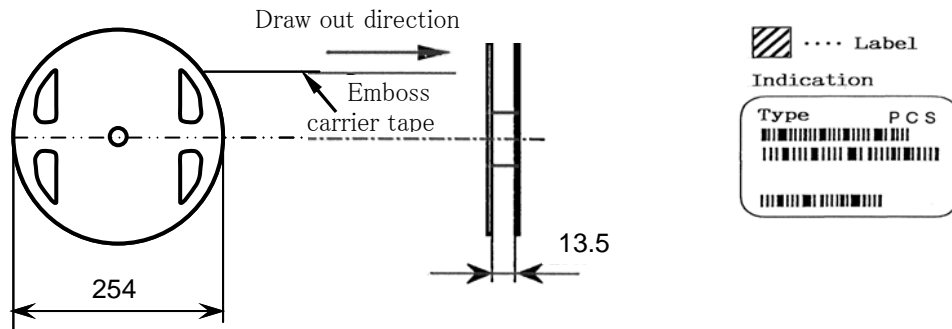

3) Packing case

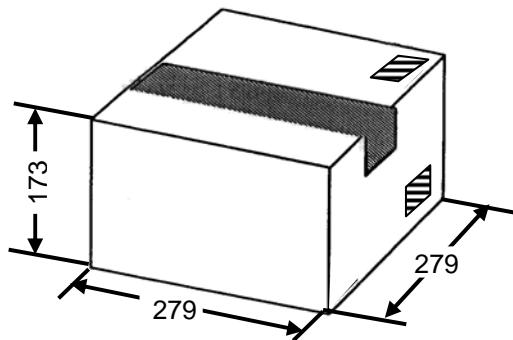

2 Packing quantity

Form	IC quantity	Contents
Reel	2000 Pcs	Reel × 1Pcs
Packing case	10000 Pcs	Reel × 5Pcs

2009.05.29		
Prepared	Revised	

	Packing Specification		Total pages	page
			3	3

Package : *QFN044-P-0606D

Unit : mm

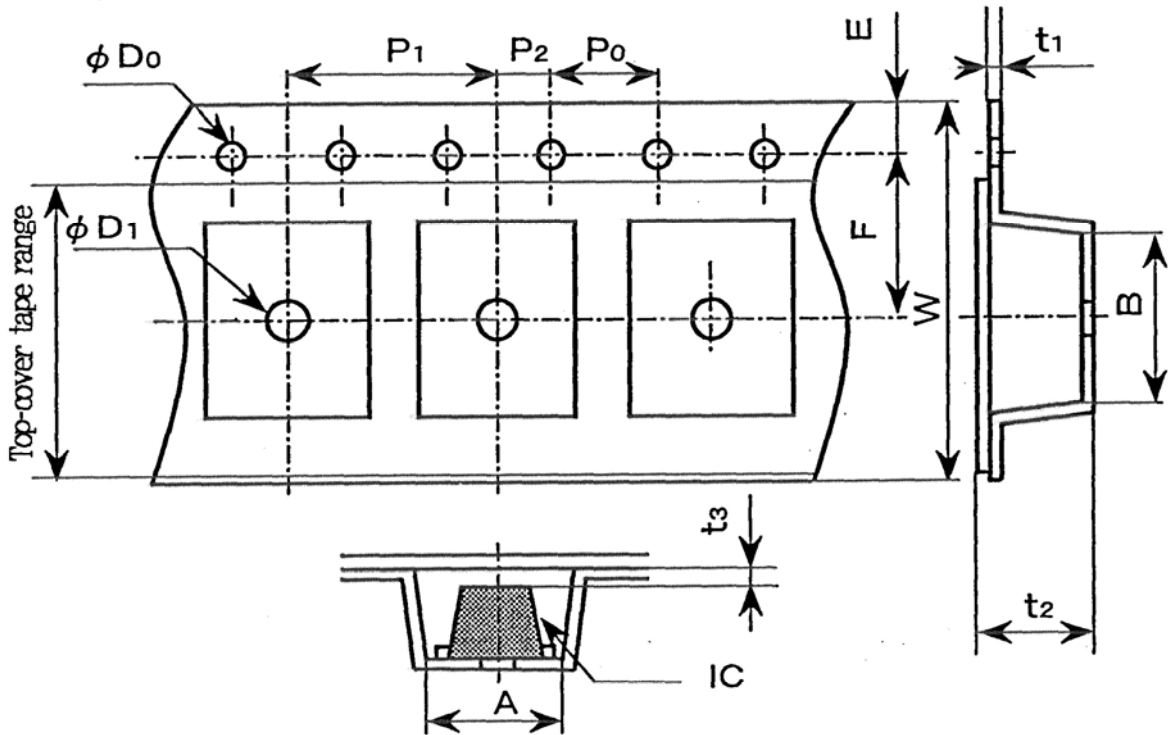

Unit:mm

Dimension & Tolerance					
W	A	B	E	F	P_1
12.0 ± 0.2	6.5 ± 0.1	6.5 ± 0.1	1.75 ± 0.1	5.5 ± 0.05	8.0 ± 0.1
P_2	P_0	ϕD_1	ϕD_0	t_1	t_2
2.0 ± 0.05	4.0 ± 0.1	$1.5^{+0.3}_{-0}$	1.55 ± 0.05	0.3 ± 0.05	1.8max
t_3					
(0.4)					

2009.05.29		
Prepared	Revised	

Panasonic

Industrial Devices Company, Panasonic Corporation

1 Kotari-yakemachi, Nagaokakyo City, Kyoto 617-8520, Japan
Tel:075-951-8151



**Стандарт
Электрон
Связь**

Мы молодая и активно развивающаяся компания в области поставок электронных компонентов. Мы поставляем электронные компоненты отечественного и импортного производства напрямую от производителей и с крупнейших складов мира.

Благодаря сотрудничеству с мировыми поставщиками мы осуществляем комплексные и плановые поставки широчайшего спектра электронных компонентов.

Собственная эффективная логистика и склад в обеспечивает надежную поставку продукции в точно указанные сроки по всей России.

Мы осуществляем техническую поддержку нашим клиентам и предпродажную проверку качества продукции. На все поставляемые продукты мы предоставляем гарантию .

Осуществляем поставки продукции под контролем ВП МО РФ на предприятия военно-промышленного комплекса России , а также работаем в рамках 275 ФЗ с открытием отдельных счетов в уполномоченном банке. Система менеджмента качества компании соответствует требованиям ГОСТ ISO 9001.

Минимальные сроки поставки, гибкие цены, неограниченный ассортимент и индивидуальный подход к клиентам являются основой для выстраивания долгосрочного и эффективного сотрудничества с предприятиями радиоэлектронной промышленности, предприятиями ВПК и научно-исследовательскими институтами России.

С нами вы становитесь еще успешнее!

Наши контакты:

Телефон: +7 812 627 14 35

Электронная почта: sales@st-electron.ru

Адрес: 198099, Санкт-Петербург,
Промышленная ул, дом № 19, литера Н,
помещение 100-Н Офис 331