



KYOCERA Display Corporation

Document Title	TVL-55728D070J-LW-I-AAN Product Information			Page No.	1/25
Document No.		Issue date	2013/03/18	Revision	04

Product Specification

To:

Product Name: TVL-55728D070J-LW-I-AAN

Document Issue Date: 2013/03/18

KYD Confidential



KYOCERA Display Corporation

Document Title	TVL-55728D070J-LW-I-AAN Product Information			Page No.	2/25
Document No.		Issue date	2013/03/18	Revision	04

Contents

1.0	General Descriptions	4
2.0	Absolute Maximum Ratings	5
3.0	Pixel Format Image	6
4.0	Optical Characteristics	7
5.0	Backlight Characteristics	10
6.0	Electrical Characteristics	11
7.0	Interface Timings	15
8.0	Power Voltage Specification	18
9.0	Power ON/OFF Sequence	19
10.0	Mechanical Characteristics	20
11.0	Reliability	22
12.0	Package Specification	23
13.0	Lot Mark	24
14.0	General Precaution	24



KYOCERA Display Corporation

Document Title	TVL-55728D070J-LW-I-AAN Product Information			Page No.	3/25
Document No.		Issue date	2013/03/18	Revision	04

Revision	Date	Page	Old Description	New Description	Remark
00	2011/12/2	all	--	First issue.	
01	2012/1/4	20	--	Add Reference Outline Drawing	
		23	--	Add Package Specification	
02	2012/1/18	18		Add the Power Voltage Specification	
03	2012/2/14	11、14		Add the Description of Connector	
04	2013/3/18	14		Modify mating connector	

KYD Confidential

Document Title	TVL-55728D070J-LW-I-AAN Product Information			Page No.	4/25
Document No.		Issue date	2013/03/18	Revision	04

1.0 General Descriptions

1.1 Introduction

The TVL-55728D070J-LW-I-AAN is a color active matrix thin film transistor (TFT) liquid crystal display (LCD) that uses amorphous silicon TFT as a switching device. It is composed of a TFT LCD panel, a backlight system, column driver and row driver circuit. This TFT LCD has a 7.0-inch diagonally measured active display area with resolution 800 horizontal by 480 vertical pixels array.

1.2 Features

- 7.0" TFT LCD Panel
- LED Backlight System
- Supported 800x480 pixels resolution
- Compatible with RoHS standard

1.3 Product Summary

Items	Specifications	Unit
Screen Diagonal	7.0	Inch
Active Area	153.60 (H) x86.64 (V)	mm
Pixels H x V	800(RGB) x480	-
Pixel Pitch	0.192(H)x0.1805 (V)	mm
Pixel Arrangement	R.G.B. Vertical Stripe	-
Display Mode	Normally White	-
White Luminance	500	cd /m ²
Contrast Ratio	500	-
Response Time	16	msec
Input Voltage	3.0	V
Weight	TBD	g
Outline Dimension	165.0(H) x104.0(V) x5.1(D)	mm
Electrical Interface (Logic)	TTL	-
Support Color	6 bits / 6 bits+HFRC	-
Optimum Viewing Direction	6 O' clock	-
Surface Treatment	Antiglare, Hard-Coating (3H) with EWV film	-

Document Title	TVL-55728D070J-LW-I-AAN Product Information			Page No.	5/25
Document No.		Issue date	2013/03/18	Revision	04

2.0 Absolute Maximum Ratings

Table 1 Electrical Absolute Rating

Item	Symbol	Min.	Max.	Unit	Conditions
Power Supply Voltage	V_{CC}	-0.3	5.0	V	GND=0
	V_{GH}	0.3	40	V	GND=0
	V_{GL}	-20	0.3	V	GND=0
	AV_{DD}	0.5	15	V	GND=0
	V_{COM}	0	6	V	-
Logic Signal Input Level	V_I	-0.3	$V_{CC}+0.3$	V	-

Note (1) Permanent damage may occur to the LCD module if beyond this specification. Functional operation should be restricted to the conditions described under normal operating conditions.

(2) Operating temperature 25□, humidity 55%.

(3) Test Condition: LED current TBDmA.

Table 2 Reliability Absolute Rating

Item	Symbol	Min.	Max.	Unit	Note
Operating Temperature	TOP	-20	70	°C	(1),(2)
Storage Temperature	TST	-30	80	°C	(1),(2)
Vibration(non-operating)	V_{nop}	-	1.5	G	(3)
Shock(non-operating)	S_{nop}	-	240	G	(4)

Note (1) There is no display function fail occurred, all the cosmetic specification is judged before the reliability stress. The criteria is fit by KYD provided IIS.

(2) The storage /operating temperature. Maximum Wet-Bulb should be 39 degree C. There is no condensation on the panel surface.

(3) 10-500Hz, random vibration, 1h for X, Y, Z axis

(4) 2ms, half sine wave, one time for X, Y, Z axis

Document Title	TVL-55728D070J-LW-I-AAN Product Information			Page No.	6/25
Document No.		Issue date	2013/03/18	Revision	04

3.0 Pixel Format Image

Figure 1 shows the relationship of the input signals and LCD pixel format image.

Figure 1 Pixel Format

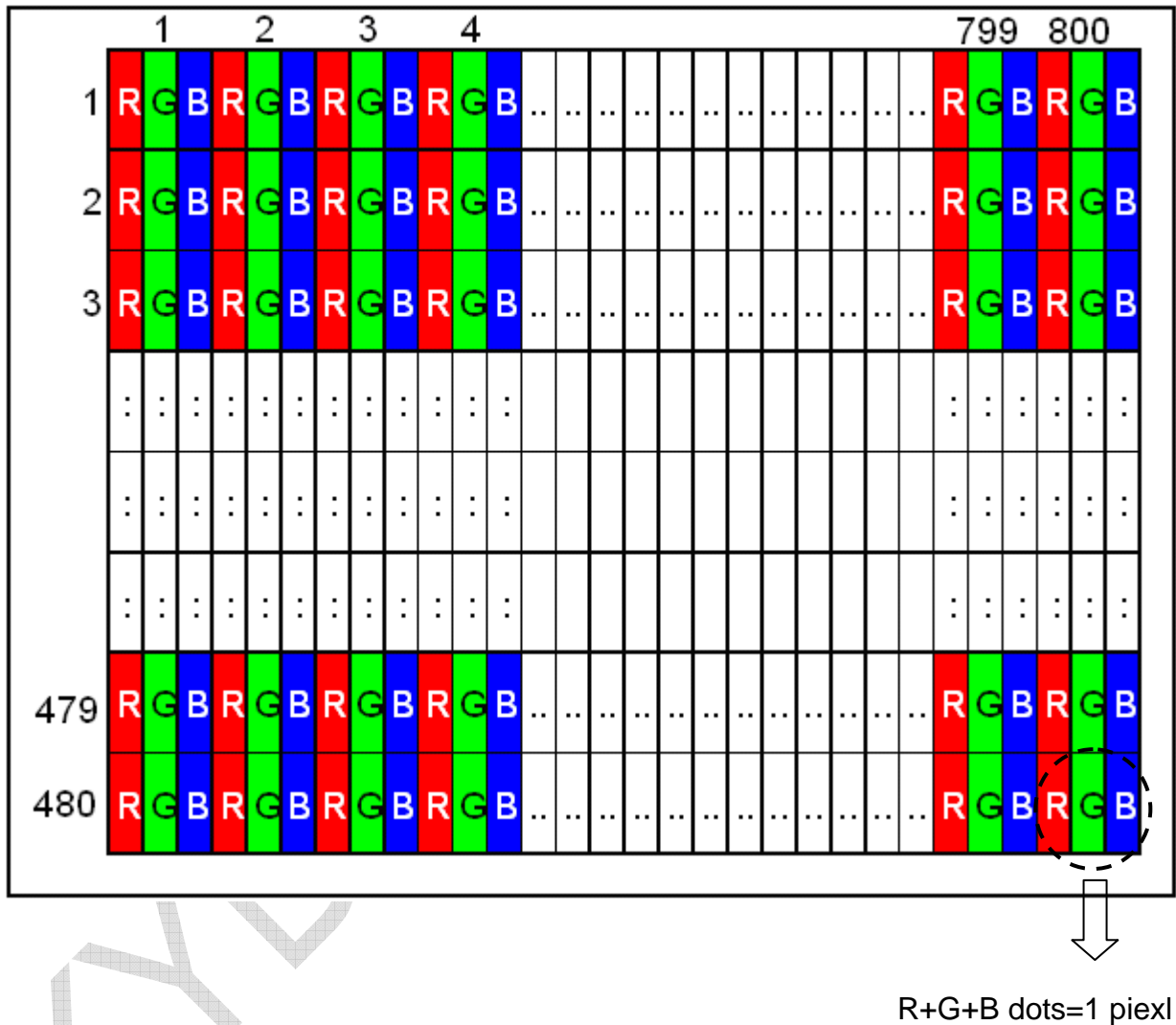

KYV

Document Title	TVL-55728D070J-LW-I-AAN Product Information			Page No.	7/25
Document No.		Issue date	2013/03/18	Revision	04

4.0 Optical Characteristics

The optical characteristics are measured under stable conditions as following notes

Table 3 Optical Characteristics

Item	Conditions		Min.	Typ.	Max.	Unit	Note		
Viewing Angle (CR>10)	Horizontal	θ_L	60	70	-	degree	(1),(2),(3)		
		θ_R	60	70	-				
	Vertical	θ_T	40	50	-				
		θ_B	50	60	-				
Contrast Ratio	Center		400	500	-	-	(1),(2),(4)		
Response Time	Rising		-	-	-	ms	(1),(2),(5)		
	Falling		-	-	-	ms			
	Rising + Falling		-	16	-	ms			
Color Chromaticity (CIE1931)	Red	x	Typ. -0.03	TBD	Typ. +0.03	-	(1),(2)		
	Red	y		TBD		-			
	Green	x		TBD		-			
	Green	y		TBD		-			
	Blue	x		TBD		-			
	Blue	y		TBD		-			
	White	x		0.305		0.310		0.315	-
	White	y		0.280		0.330		0.380	-
White Luminance	Center		400	500	-	cd/m ²	(1),(2),(6)		
Luminance Uniformity	9Points		70	-	-	%	(1),(2),(6)		

Document Title	TVL-55728D070J-LW-I-AAN Product Information	Page No.	8/25
Document No.		Issue date	2013/03/18
		Revision	04

Note (1) Measurement Setup:

The LCD module should be stabilized at given temperature(25°C) for 15 minutes to Avoid abrupt temperature change during measuring. In order to stabilize the luminance, the measurement should be executed after lighting backlight for 15 minutes in a windless room.

Figure 2 Measurement Setup

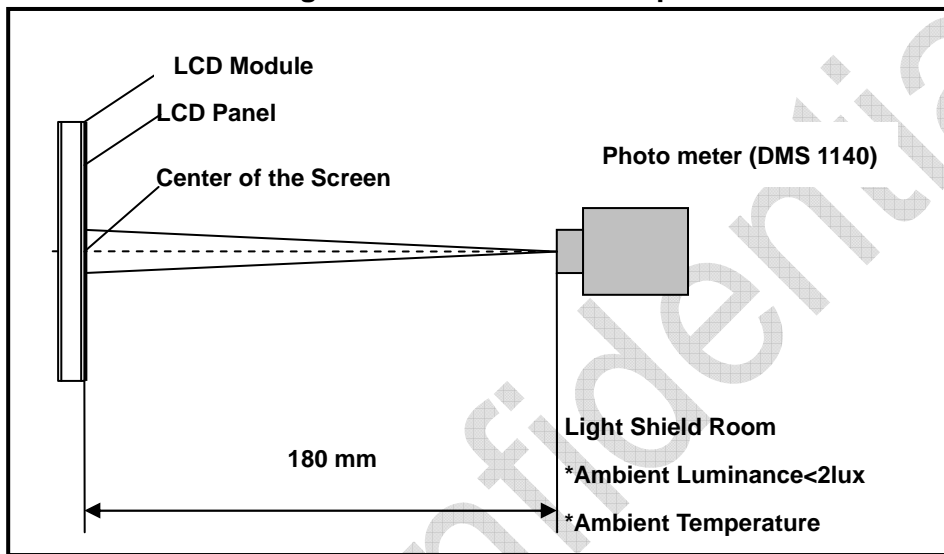

Note (2) The LED input parameter setting as: I_LED: TBD

Note (3) Definition of Viewing Angle

Figure 3 Definition of Viewing Angle

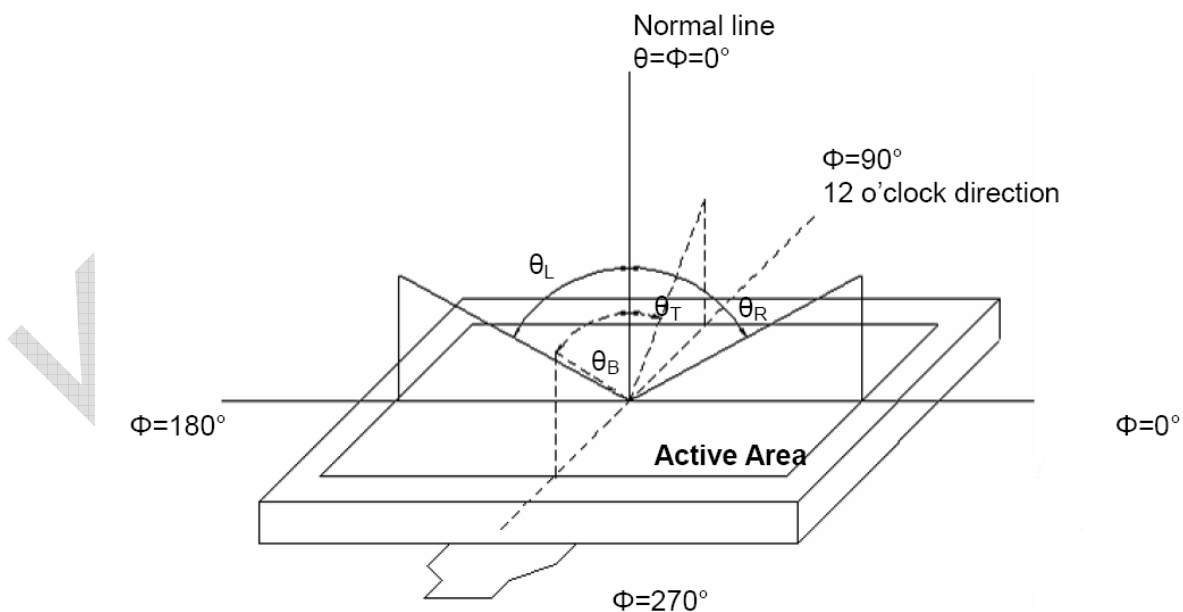

Note (4) Definition Of Contrast Ratio (CR)

Document Title	TVL-55728D070J-LW-I-AAN Product Information	Page No.	9/25
Document No.		Issue date	2013/03/18
		Revision	04

The contrast ratio can be calculated by the following expression

$$\text{Contrast Ratio (CR)} = L63 / L0$$

L63: Luminance of gray level 63, L0: Luminance of gray level 0

Note (5) Definition Of Response Time (T_R , T_F)

Figure 4 Definition of Response Time

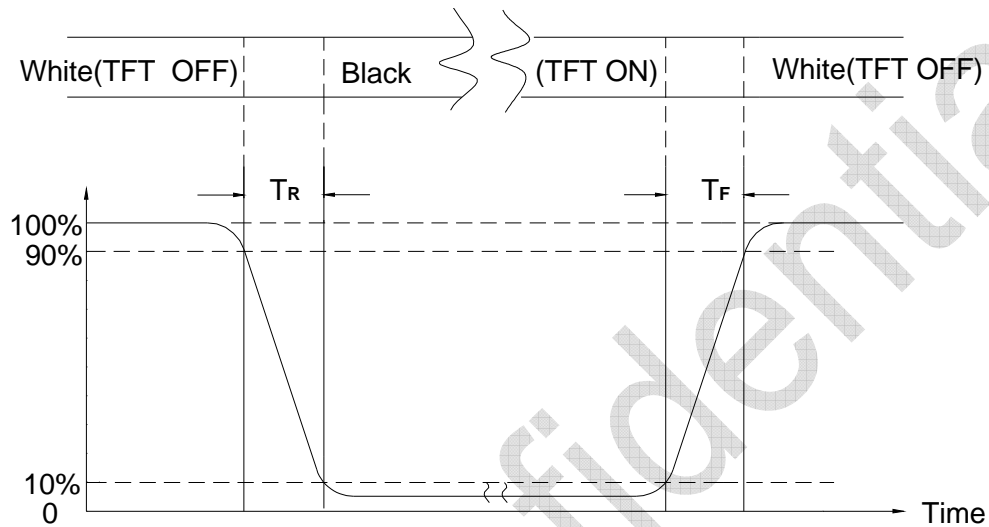

Note (6) Definition Of brightness Luminance

$$\text{Luminance uniformity} = \frac{(\text{Min Luminance of 9 points})}{(\text{Max Luminance of 9 points})} \times 100\%$$

H—Active area length V—Active area width

Figure 5 Measurement Locations

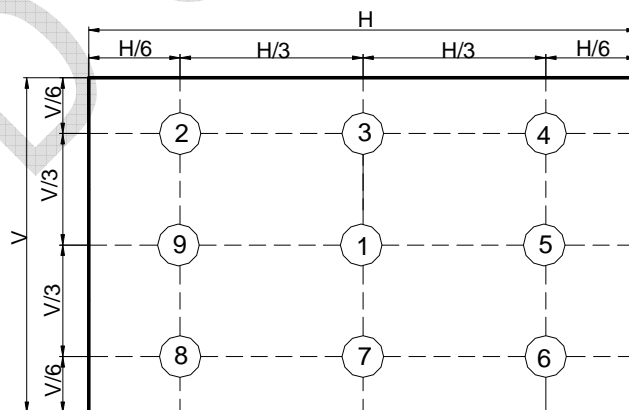

Document Title	TVL-55728D070J-LW-I-AAN Product Information			Page No.	10/25
Document No.		Issue date	2013/03/18	Revision	04

5.0 Backlight Characteristics

Table 4 Parameter Guideline for LED Backlight

Item	Symbol	Min.	Typ.	Max.	Units	Conditon
LED Voltage	V_L	-	26.4	-	V	Ta=25℃
LED Current	I_L	-	120	-	m A	
LED Forward Voltage	V_F		TBD		V	
LED Forward Current	I_F		TBD		m A	
BL Power Consumption	P_L	-	-	TBD	W	
LED Life Time	-	50,000	-	-	Hours	Ta=25℃/I _L = TBD Note (1)

Note (1) The LED life time define as the estimated time to 50% degradation of initial luminous.

(2) The backlight structure is edge lighting with 16 LED

Figure 5 LED Light Bar Structure



Document Title	TVL-55728D070J-LW-I-AAN Product Information			Page No.	11/25
Document No.		Issue date	2013/03/18	Revision	04

6.0 Electrical Characteristics

6.1 TFT LCD Module Interface

Table 6 Connector Name / Designation

Item	Description
FPC Down Connector	FH28-60S-0.5SH (HIROSE),60pin pitch=0.5mm

Table 7 Signal Pin Assignment

Pin #	Signal Name	Description	Remarks
1	AGND	Analog Ground	-
2	AVDD	Analog Power	-
3	VCC	Digital Power	-
4	R0	Data Input(LSB)	-
5	R1	Data Input	-
6	R2	Data Input	-
7	R3	Data Input	-
8	R4	Data Input	-
9	R5	Data Input	-
10	R6	Data Input	-
11	R7	Data Input(MSB)	-
12	G0	Data Input(LSB)	-
13	G1	Data Input	-
14	G2	Data Input	-
15	G3	Data Input	-
16	G4	Data Input	-
17	G5	Data Input	-
18	G6	Data Input	-
19	G7	Data Input(MSB)	-
20	B0	Data Input(LSB)	
21	B1	Data Input	
22	B2	Data Input	
23	B3	Data Input	
24	B4	Data Input	
25	B5	Data Input	
26	B6	Data Input	
27	B7	Data Input(MSB)	

Document Title	TVL-55728D070J-LW-I-AAN Product Information			Page No.	12/25
Document No.		Issue date	2013/03/18	Revision	04

28	DCLK	Clock input	
29	DE	Data Enable Signal	
30	HSD	Horizontal Sync Input. Negative Polarity	
31	VSD	Vertical Sync Input .Negative Polarity	
32	MODE3	DE/SYNC Mode Select .Normally Pull High H:DE	
33	RSTB	Global Reset Pin .Active low to enter reset state .Suggest to connecting with an RC reset circuit for stability .Normally pull high.	
34	STBYB	Standby mode, normally pull high STBYB="1", normal operation STBYB="0", timing control , source driver will turn off ,all output are high-Z	
35	SHLR	Source right or left sequence control. SHLR="L", shift left: last data=S1<-S2...S1200=first data SHLR="H", shift right: first data=S1->SS2...S1200=last data	
36	VCC	Digital Power	
37	UPDN	Gate Up or Down Scan Control. UPDN="L" , DOWN Shift :G1->G2...->G960 ; UPDN="H", up shift: G1<-G2...<-G960	
38	GND	Digital Ground	
39	AGND	Analog Ground	
40	AVDD	Analog Power	
41	VCOM in	For external VCOM DC Input (Adjustable)	-
42	DITH	Dithering Setting: DITH="H" 6bit resolution (last 2 bits of input data truncated) (default setting) DITH="L" 8bit resolution	-
43	NC	Not Connect	-
44	NC	Not Connect	-
45	V10	Gamma Correction Voltage Reference	-
46	V9	Gamma Correction Voltage Reference	-
47	V8	Gamma Correction Voltage Reference	-
48	V7	Gamma Correction Voltage Reference	-
49	V6	Gamma Correction Voltage Reference	-
50	V5	Gamma Correction Voltage Reference	-
51	V4	Gamma Correction Voltage Reference	-



KYOCERA Display Corporation

Document Title	TVL-55728D070J-LW-I-AAN Product Information			Page No.	13/25
Document No.		Issue date	2013/03/18	Revision	04

52	V3	Gamma Correction Voltage Reference	-
53	V2	Gamma Correction Voltage Reference	-
54	V1	Gamma Correction Voltage Reference	-
55	NC	Not connect→ Panel Self Test (BIST)	High Enable
56	VGH	Positive Power for TFT	-
57	VCC	Digital Power	-
58	VGL	Negative Power for TFT	-
59	GND	Digital Ground	-
60	NC	Not Connect	-

Note : All input signals shall be low or Hi-resistance state when VDD is off.



KYOCERA Display Corporation

Document Title	TVL-55728D070J-LW-I-AAN Product Information			Page No.	14/25
Document No.		Issue date	2013/03/18	Revision	04

6.2 Backlight Unit

Table 8 Connector Name / Designation

Item	Description
LED Power Source	(BHSR-02VS-1) or equivalent
Mating Connector	BHSMR-02VS

Table 9 Signal Pin Assignment

Pin #	Color	Function
1	Black	LED Power Supply (26.4V)
2	White	LED Low Voltage (GND)

Document Title	TVL-55728D070J-LW-I-AAN Product Information			Page No.	15/25
Document No.		Issue date	2013/03/18	Revision	04

7.0 Interface Timings

7.1 Timing Characteristics

Table 10 Interface Timings

Item	Symbol	Min.	Typ.	Max.	Unit	Note
DCLK cycle time	Tcph	25	-	-	ns	-
DCLK frequency	fclk	-	30	40	MHZ	-
DCLK pulse duty	Tcwh	40	50	60	%	-
VSD setup time	Tvst	8	-	-	ns	-
VSD hold time	Tvhd	8	-	-	ns	-
HSD setup time	Thst	8	-	-	ns	-
HSD hold time	Thhd	8	-	-	ns	-
Data setup time	Tdsu	8	-	-	ns	-
Data hold time	Tdhd	8	-	-	ns	-
DE setup time	Tesu	8	-	-	ns	-
DE hold time	Tehd	8	-	-	ns	-
Horizontal display area	thd	-	800	-	Tcph	-
HSD period time	th	-	928	-	Tcph	-
HSD pulse width	thpw	1	48	-	Tcph	-
HSD back porch	thb	-	40	-	Tcph	-
HSD front porch	thfp	-	40	-	Tcph	-
Vertical display area	tvd	-	480	-	th	-
VSD period time	tv	-	525	-	th	-
VSD pulse width	tvpw	-	3	-	th	-
VSD back porch	tvb	-	29	-	th	-
VSD front porch	tvfp	-	13	-	th	-

Document Title	TVL-55728D070J-LW-I-AAN Product Information	Page No.	16/25
Document No.		Issue date	2013/03/18
		Revision	04

7.2 Timing Diagram of Interface Signal

Figure 6 Timing Characteristics

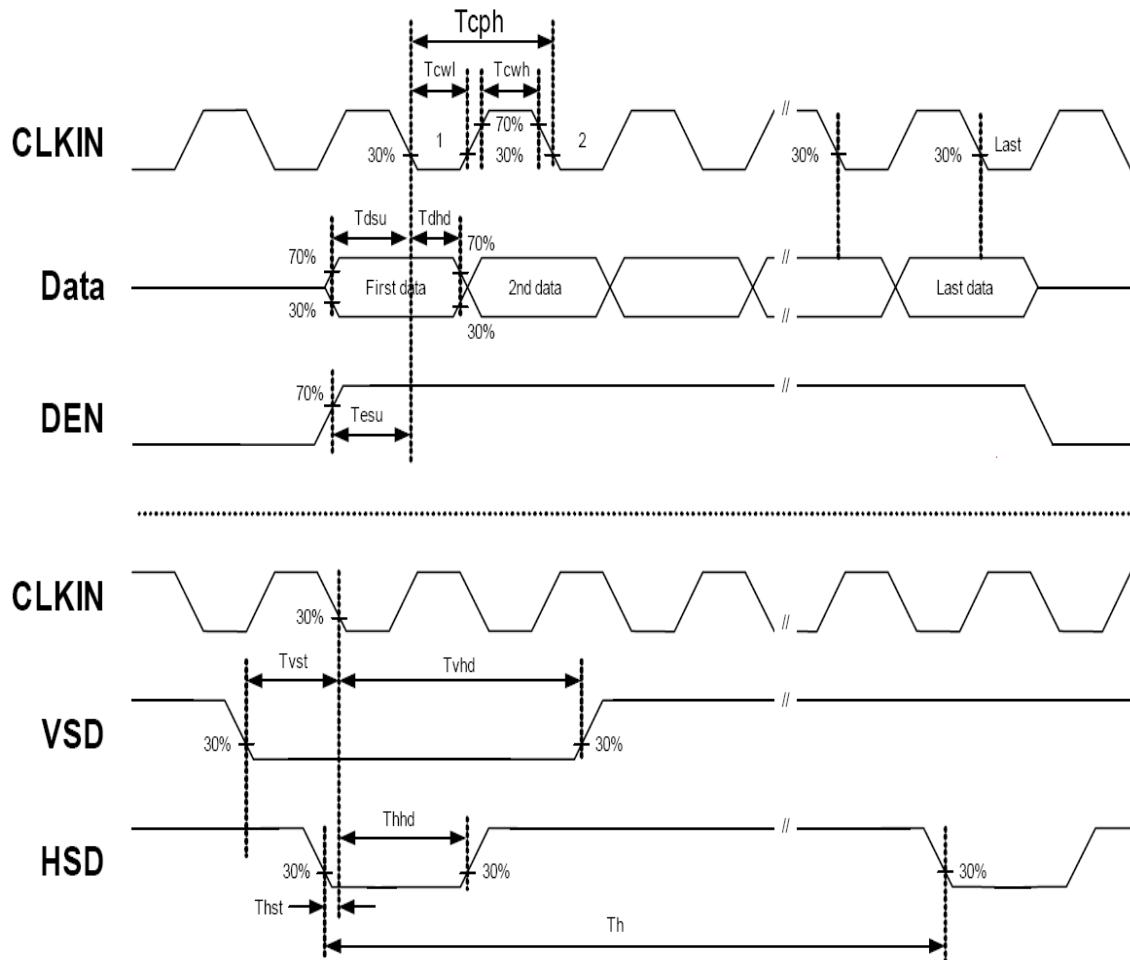

KYD

Document Title	TVL-55728D070J-LW-I-AAN Product Information			Page No.	17/25
Document No.		Issue date	2013/03/18	Revision	04

Figure 7 Horizontal display timing range

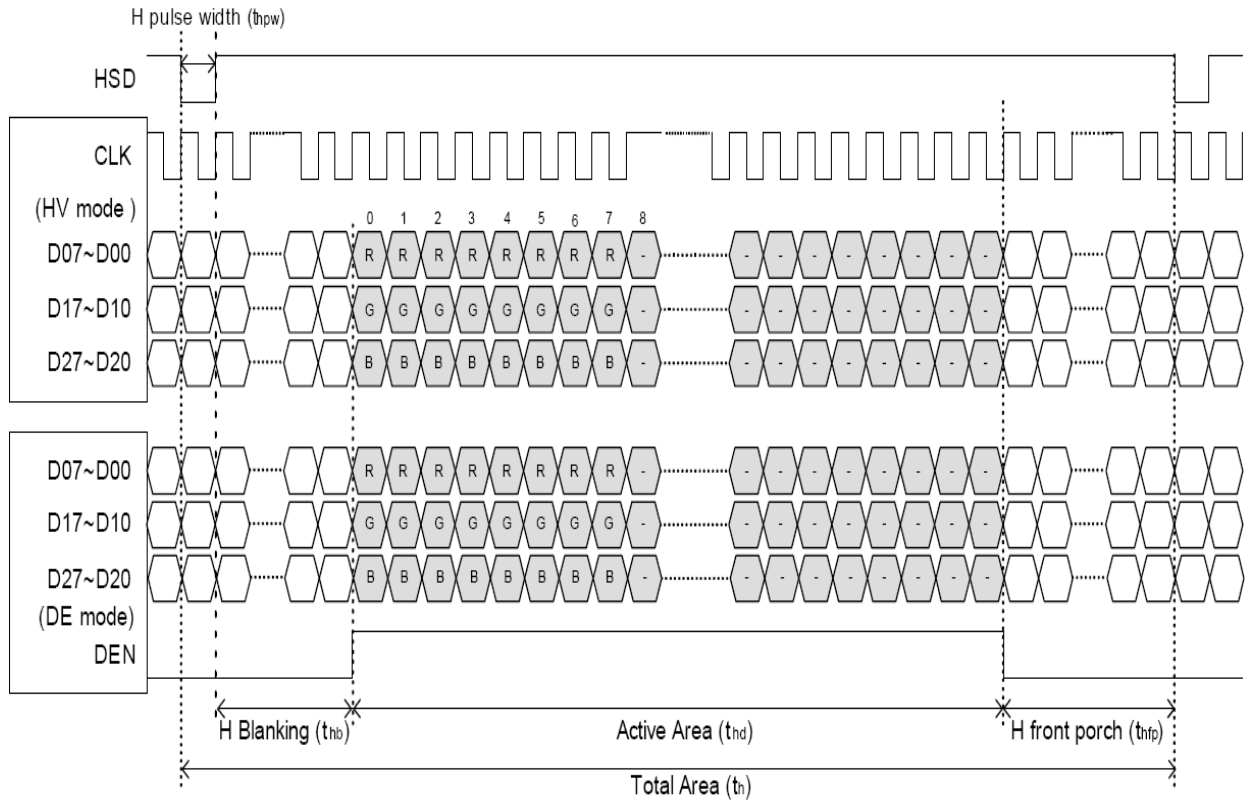
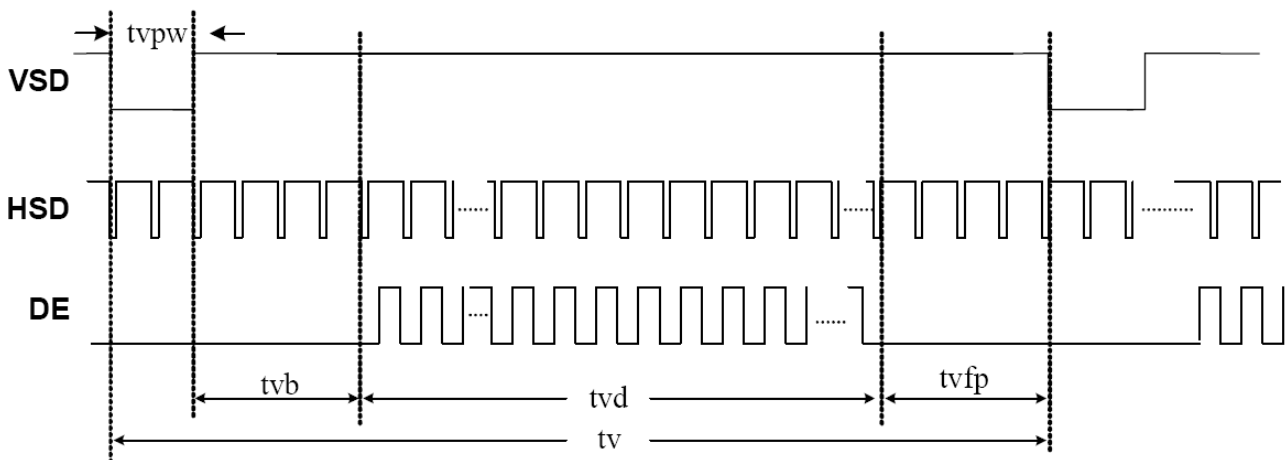

Figure 8 Vertical timing



Document Title	TVL-55728D070J-LW-I-AAN Product Information			Page No.	18/25
Document No.		Issue date	2013/03/18	Revision	04

8.0 Power Voltage Specification

Input power voltage specifications are as follows.

Table 11 Power Voltage

Item	Symbol	Min.	Typ.	Max.	Units	Note
Supply Voltage	V_{CC}	3.0	3.3	3.6	V	-
	V_{GH}	-	22	-	V	-
	V_{GL}	-	-7	-	V	-
	AV_{DD}	-	(10.4)	-	V	-
Input signal voltage	V_{IH}	$0.7 V_{CC}$	-	V_{CC}	V	-
Input signal voltage	V_{IL}	0	-	$0.3V_{CC}$	V	-
VCOM	VCOM in	-	(3.8)	-	V	-
Input level of V1~V5	V_{ref}	$0.4 \cdot AV_{DD}$	-	$AV_{DD}-0.1$	V	-
Input level of V6~V10	V_{ref}	AGND+0.1	-	$0.6 \cdot AV_{DD}$	V	AGND=0V

8.1 Reference Gamma Circuit

Figure 9 Gamma Circuit

TBD

Gamma Voltage (V)

V1	10.200
V2	8.390
V3	7.840
V4	7.530
V5	5.540
V6	4.860
V7	3.270
V8	2.760
V9	2.010
V10	0.200

Document Title	TVL-55728D070J-LW-I-AAN Product Information			Page No.	19/25
Document No.		Issue date	2013/03/18	Revision	04

9.0 Power ON/OFF Sequence

Power on/off sequence is as follows. Interface signals are also shown in the chart. Signals from any system shall be Hi-resistance state or low level when VDD is off.

Figure 10 Power Sequence

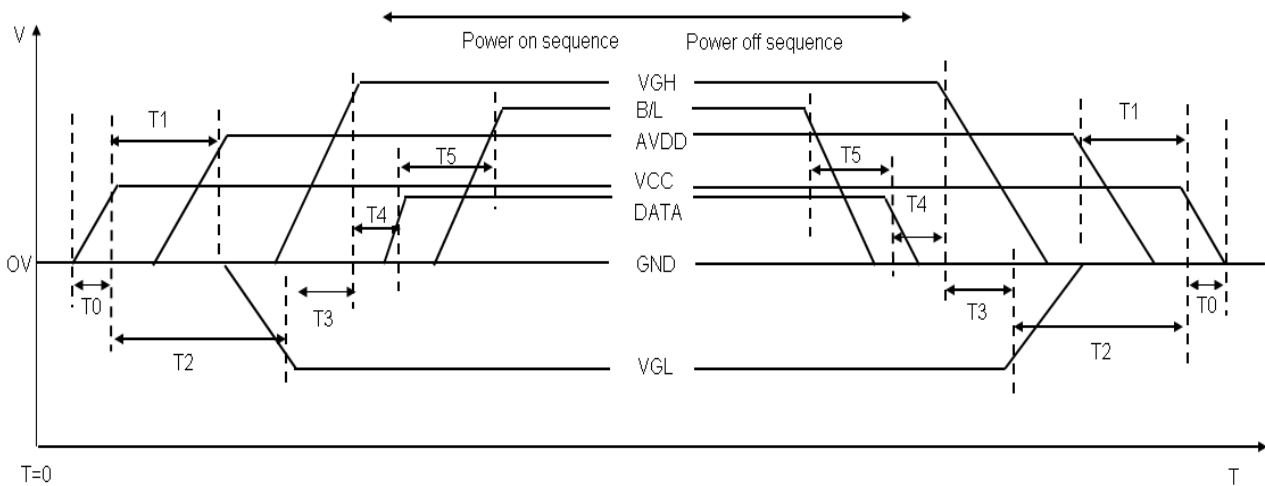

Table 12 Power Sequencing Requirements

Item	Min.	Typ.	Max.	Unit
T0	0.5	-	20	ms
T1	16	-	-	ms
T2	20	-	-	ms
T3	10	-	-	ms
T4	10	-	50	ms
T5	50	-	-	ms

Note (1) Power On Sequence: VCC-> AVDD -> VGL -> VGH -> Data -> B/L

(2) Power Off Sequence: B/L-> Data -> VGH -> VGL -> AVDD -> VCC

Document Title	TVL-55728D070J-LW-I-AAN Product Information		Page No.	20/25	
Document No.		Issue date	2013/03/18	Revision	04

10.0 Mechanical Characteristics

10.1 Outline Drawing

Figure 11 Outline Drawing (Front Side)

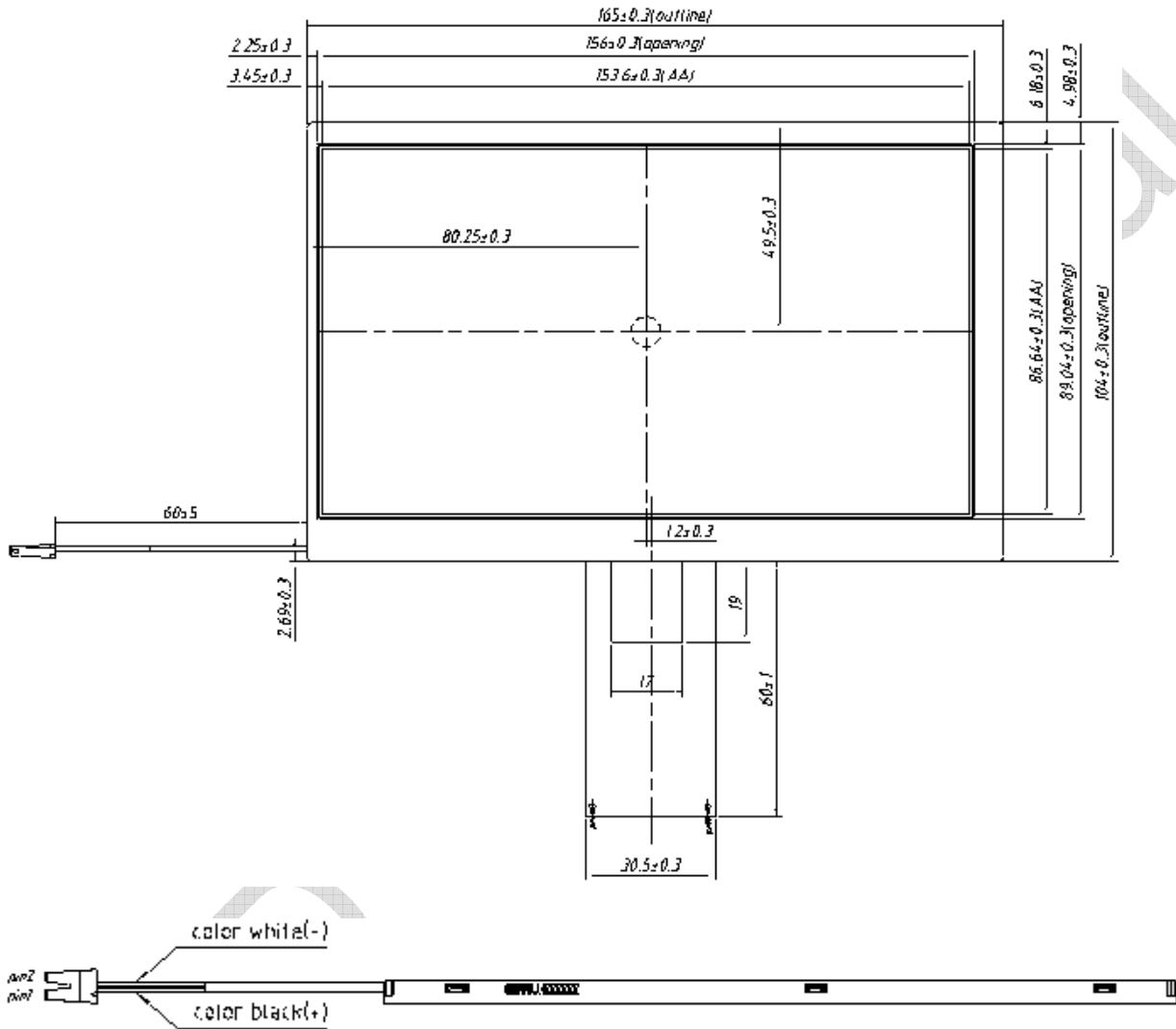

Document Title	TVL-55728D070J-LW-I-AAN Product Information			Page No.	21/25
Document No.		Issue date	2013/03/18	Revision	04

Figure 12 Outline Drawing (Back Side)

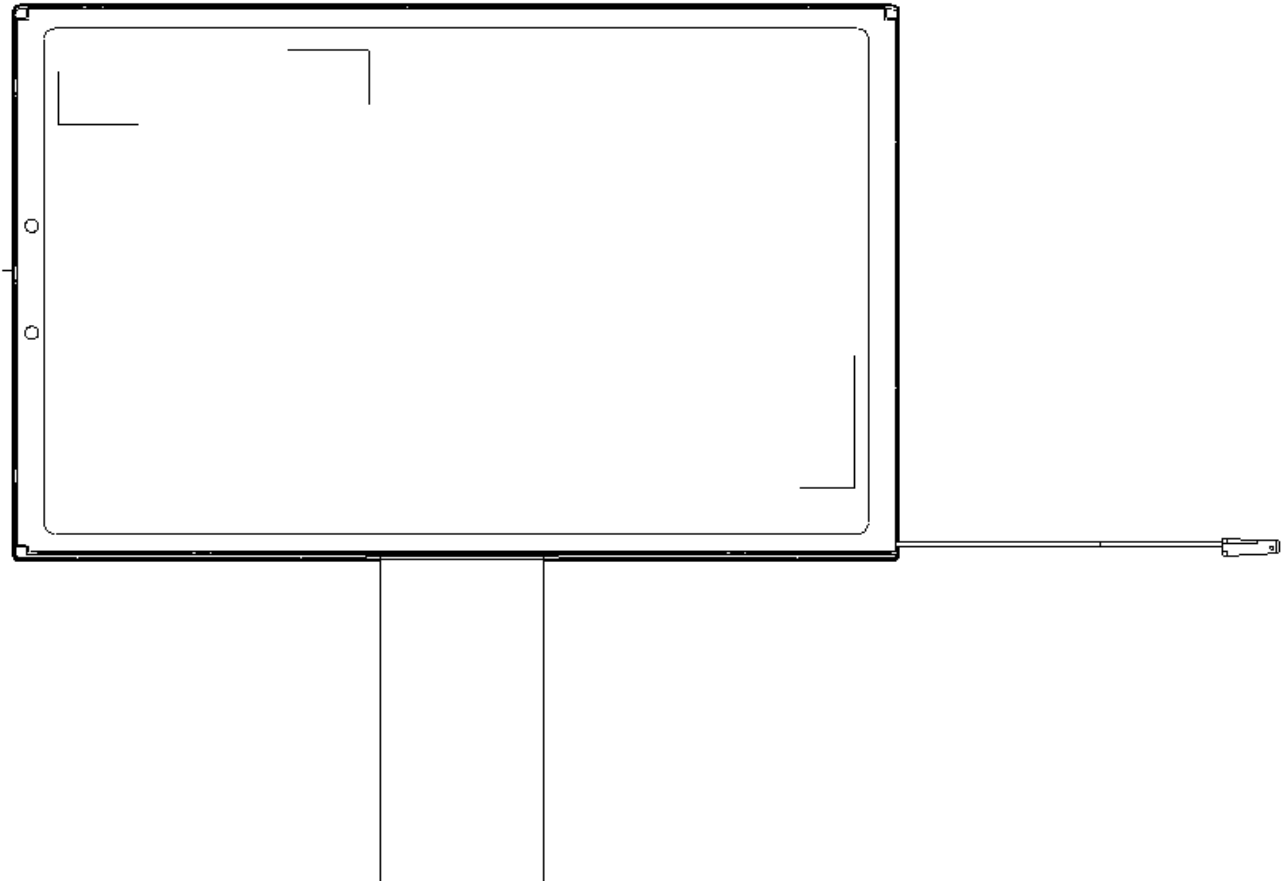

10.2 Dimension Specifications

Table 13 Module Dimension Specifications

Item	Parameter	Min.	Typ.	Max.	Units
Module Size	Horizontal(H)	164.7	165.0	165.3	mm
	Vertical(V)	103.7	104.0	104.3	mm
	Depth(D)	-	5.1	5.4	mm
Weight	-	-	TBD	-	g

Document Title	TVL-55728D070J-LW-I-AAN Product Information			Page No.	22/25
Document No.		Issue date	2013/03/18	Revision	04

11.0 Reliability

Item	Criterion
A	<p>Occurrence of any new defective symptom or exteriorization of potential defects shall not be allowed.(stain/blotch,ununiformity,dot defect, line defect,bubble,gravity mura,mirco dot defect, electrical discharge time, butterfly mura,mura by backlight unit,etc.)</p> <p>Any progress shall not be allowed either.</p> <p>It is judged from the view of all direction at room temperature.</p> <p>Check pattern is R/G/B/W/Black V0-V63(V8 step),Window pattern,V63=V100%</p>
B	<p>Image Sticking is not visible through 8% ND filter.</p> <p>Stain at window edge is not visible through 8% ND filter</p>
C	Image Sticking is not visible through 8% ND filter after 10 mins with pattern L127.
D	Cosmetic must be in spec.

Item	Package	Test Conditions	Conditions	
High Temperature Storage Test	Module	80°C, 500hrs	A	
Low Temperature Storage Test	Module	-30°C, 500hrs	A	
High Temperature Operation Test	Module	70°C, 500hrs	A,B	
Low Temperature Operating Test	Module	-20°C, 500hrs	A	
High Temp./High Humidity Operating Test	Module	50°C, 85%, 500hrs	A	
Thermal Shock Non-operation Test	Module	-30°C ~ 80°C;1hr/each cycle,200cycles	A	
Shock Test	With package	Half Sine Wave ±X,Y, Z 240G,2ms, 1 Times each axis	A,D	
Vibration Test	With package	1.5G, 10~500 Hz, x、y、z each axis/1h		
Drop Test	With package	65cm, 1corner,3 aris, 6 side		
ESD Test	operating	Module	contact	± 8 KV
			air	± 15 KV
Image Sticking test	Module	25°C ,chess pattern (5*7)test 8hrs	C	

Document Title	TVL-55728D070J-LW-I-AAN Product Information	Page No.	23/25
Document No.		Issue date	2013/03/18
		Revision	04

12.0 Package Specification

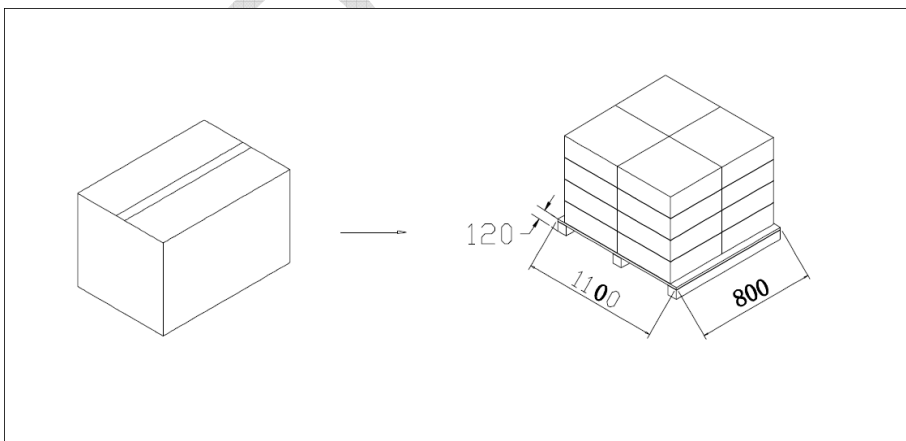
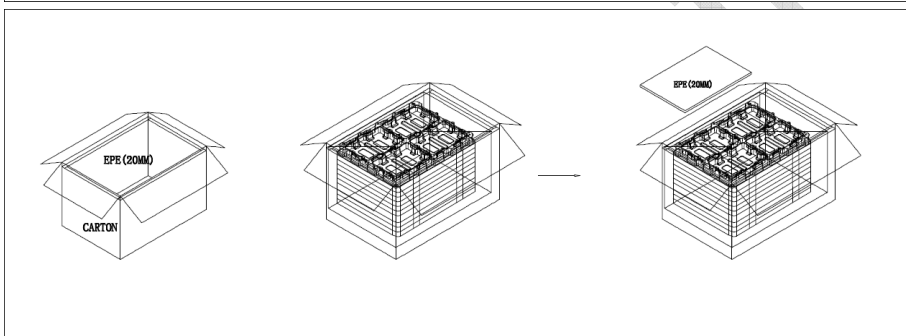
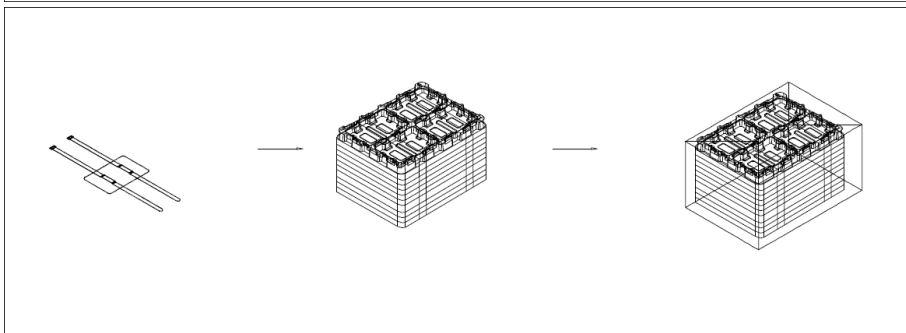
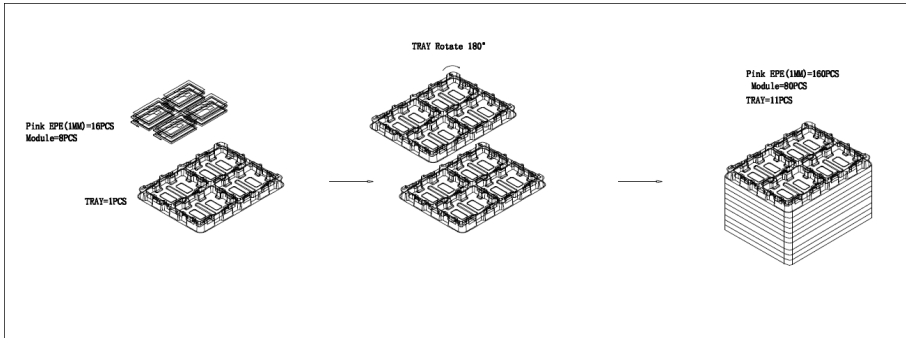

Confidential



KYOCERA Display Corporation

Document Title	TVL-55728D070J-LW-I-AAN Product Information			Page No.	24/25
Document No.		Issue date	2013/03/18	Revision	04

Components Material	Module	Tray	Pink EPE	PP Plate	Banding	PE Bag	Top &Bottom EPE	Front &Back EPE	Left &Right EPE	Carton
Material Size(mm)	165*104* 5.0mm	426*3 26*30 mm	164*103*1 mm	426*326* 5mm	(1500+ 100)*25 mm	730*460* 0.1mm	466*366* 20mm	426*2 66*20 mm	366*2 66*20 mm	481*381* 331mm
Amount (Pcs /Carton)	80	11	160	1	2	1	2	2	2	1

Weight Spec.	
Kg/Carton	10~12

13.0 Lot Mark

TBD

14.0 General Precaution

13.1 Use Restriction

This product is not authorized for use in life supporting systems, aircraft navigation control systems, military systems and any other application where performance failure could be life-threatening or otherwise catastrophic.

13.2 Handling Precaution

- (1) Please mount LCD module by using mounting holes arranged in four corners tightly.
- (2) Do not disassemble or modify the module. It may damage sensitive parts inside LCD module, and may cause scratches or dust on the display. KYD does not warrant the module, if customers disassemble or modify the module.
- (3) If LCD panel is broken and liquid crystal spills out, do not ingest or inhale liquid Crystal, and do not contact liquid crystal with skin. If liquid crystal contacts mouth or eyes, rinse out with water immediately. If liquid crystal contacts skin or cloths, wash it off immediately with alcohol and Rinse thoroughly with water.
- (4) Disconnect power supply before handling LCD module
- (5) Refrain from strong mechanical shock and /or any force to the module.
- (6) Do not exceed the absolute maximum rating values, such as the supply voltage variation, input voltage variation, variation in parts' parameters, environmental temperature; etc otherwise LCD module may be damaged. It's recommended employing protection circuit for power supply.
- (7) Do not touch, push or rub the polarizer with anything harder than HB pencil lead. Use fingerstalls of soft gloves in order to keep clean display quality, when Persons handle the LCD module for incoming inspection or assembly.
- (8) When the surface is dusty, please wipe gently with absorbent cotton or other soft Material. When cleaning the adhesives, please use absorbent cotton wetted with a little Petroleum benzene or other adequate solvent.
- (9) Wipe off saliva or water drops as soon as possible. If saliva or water drops Contact with polarizer for a long time, they may causes deformation or color Fading.

Document Title	TVL-55728D070J-LW-I-AAN Product Information			Page No.	25/25
Document No.		Issue date	2013/03/18	Revision	04

(10) Protection film must remove very slowly from the surface of LCD module to Prevent from electrostatic occurrence.

(11) Because LCD module uses CMOS-IC on circuit board and TFT-LCD panel, it is Very weak to electrostatic discharge, Please be careful with electrostatic Discharge .Persons who handle the module should be grounded through adequate methods.

(12) Do not adjust the variable resistor located on the module.

13.3 Storage Precaution

(1) Please do not leave LCD module in the environment of high humidity and high temperature for a long time.

(2) The module shall not be exposed under strong light such as direct sunlight. Otherwise, Display characteristics may be changed.

(3) The module should be stored in a dark place. It is prohibited to apply sunlight or fluorescent light in storage.

13.4 Operation Precaution

(1) Do not connect or disconnect the module in the "Power On" condition.

(2) Power supply should always be turned on/off by 9.0 "Power on/off sequence"

(3) Module has high frequency circuits. Sufficient suppression to the electromagnetic interference should be done by system manufacturers. Grounding and shielding methods may be important to minimize the interference.

(4) After installation of the TFT Module into an enclosure, do not twist nor bend the TFT Module even momentary. At designing the enclosure, it should be taken into consideration that no bending/twisting forces are applied to the TFT Module from outside. Otherwise the TFT Module may be damaged.

13.5 Others

(1) Ultra-violet ray filter is necessary for outdoor operation.

(2) Avoid condensation of water which may result in improper operation or disconnection of electrode.

(3) If the module keeps displaying the same pattern for a long period of time, the image may be "sticked" to the screen.

(4) This module has its circuitry PCB's on the rear side and should be handled carefully in order not to be stressed.

13.6 Disposal

When disposing LCD module, obey the local environmental regulations.



Стандарт Электрон Связь

Мы молодая и активно развивающаяся компания в области поставок электронных компонентов. Мы поставляем электронные компоненты отечественного и импортного производства напрямую от производителей и с крупнейших складов мира.

Благодаря сотрудничеству с мировыми поставщиками мы осуществляем комплексные и плановые поставки широчайшего спектра электронных компонентов.

Собственная эффективная логистика и склад в обеспечивает надежную поставку продукции в точно указанные сроки по всей России.

Мы осуществляем техническую поддержку нашим клиентам и предпродажную проверку качества продукции. На все поставляемые продукты мы предоставляем гарантию .

Осуществляем поставки продукции под контролем ВП МО РФ на предприятия военно-промышленного комплекса России , а также работаем в рамках 275 ФЗ с открытием отдельных счетов в уполномоченном банке. Система менеджмента качества компании соответствует требованиям ГОСТ ISO 9001.

Минимальные сроки поставки, гибкие цены, неограниченный ассортимент и индивидуальный подход к клиентам являются основой для выстраивания долгосрочного и эффективного сотрудничества с предприятиями радиоэлектронной промышленности, предприятиями ВПК и научно-исследовательскими институтами России.

С нами вы становитесь еще успешнее!

Наши контакты:

Телефон: +7 812 627 14 35

Электронная почта: sales@st-electron.ru

Адрес: 198099, Санкт-Петербург,
Промышленная ул, дом № 19, литера Н,
помещение 100-Н Офис 331