

Evaluation Boards for Full-Duplex and Half-Duplex RS-485 Transceivers in 8-lead/14-lead SOIC Packages

FEATURES

- Easy evaluation of half- and full-duplex RS-485 transceivers
- Board layouts for standard RS-485 SOIC footprints
 - 8-lead, SOIC, half-duplex RS-485 ([EVAL-RS485HDEBZ](#))
 - 8-lead, SOIC, full-duplex RS-485 ([EVAL-RS485FD8EBZ](#))
 - 14-lead, SOIC, full-duplex RS-485 ([EVAL-RS485FDEBZ](#))
- Power/ground connections through screw terminal blocks
- Screw terminal blocks for logic I/O and RS-485 signals
- Jumper selectable enable/disable for \overline{RE} and DE
- Test points for measuring all signals
- Resistors and footprints for termination and biasing networks

APPLICATIONS

Full- and half-duplex RS-485 transceiver evaluation

EVALUATION KIT CONTENTS

- 1 [EVAL-RS485HDEBZ](#) or
 - 1 [EVAL-RS485FD8EBZ](#) or
 - 1 [EVAL-RS485FDEBZ](#)
- (Main device available separately when ordering)

GENERAL DESCRIPTION

The [EVAL-RS485HDEBZ](#), [EVAL-RS485FD8EBZ](#), and [EVAL-RS485FDEBZ](#) allow quick and easy evaluation of RS-485 transceivers with standard SOIC footprints. The evaluation board allows all of the input and output functions to be exercised without the need for external components. Screw terminal blocks provide convenient connections for power and ground, digital I/O, and RS-485 signals.

The [EVAL-RS485HDEBZ](#) evaluation board has a footprint for a half-duplex RS-485 transceiver in an 8-lead SOIC package. The [EVAL-RS485FD8EBZ](#) evaluation board has a footprint for a full-duplex RS-485 transceiver in an 8-lead SOIC package. The [EVAL-RS485FDEBZ](#) evaluation board has a footprint for a full-duplex RS-485 transceiver in a 14-lead SOIC package.

EVAL-RS485HDEBZ



Figure 1.

EVAL-RS485FD8EBZ



Figure 2.

EVAL-RS485FDEBZ



Figure 3.

TABLE OF CONTENTS

Features	1	Other Board Components.....	4
Applications.....	1	Evaluation with Applications.....	4
Evaluation Kit Contents.....	1	Evaluation Board Schematics and Layouts	7
General Description	1	EVAL-RS485HDEBZ	7
EVAL-RS485HDEBZ	1	EVAL-RS485FD8EBZ	9
EVAL-RS485FD8EBZ	1	EVAL-RS485FDEBZ	11
EVAL-RS485FDEBZ.....	1	Ordering Information.....	13
Revision History	2	EVAL-RS485HDEBZ Bill of Materials	13
Evaluation Board Configuration	3	EVAL-RS485FD8EBZ Bill of Materials	14
Setting Up the Evaluation Board.....	3	EVAL-RS485FDEBZ Bill of Materials	15
Input/Output Connections	3	Related Links.....	16

REVISION HISTORY

4/13—Revision 0: Initial Version

EVALUATION BOARD CONFIGURATION

SETTING UP THE EVALUATION BOARD

In order to allow evaluation of any one of over 40 RS-485 transceivers, the evaluation boards are supplied with an unpopulated footprint for the RS-485 transceiver. The evaluation board allows all of the input and output functions to be exercised without the need for additional external components. Jumper configurations are shown in Table 2.

To use the [EVAL-RS485HDEBZ](#), fit an 8-lead SOIC half-duplex transceiver to the footprint in the center of the board. For the [EVAL-RS485FD8EBZ](#), fit an 8-lead SOIC full-duplex transceiver to the footprint, and for the [EVAL-RS485FDEBZ](#), a 14-lead SOIC full-duplex transceiver. Refer to Table 1 for a list of parts available for each board.

The board is powered by connecting a 3.3 V or 5 V power supply (refer to Table 1) to the screw terminals for VCC and GND at the top of the evaluation board. A 22 μ F or 10 μ F decoupling capacitor, C1, is fitted at the connector between VCC and GND. The VCC pin of the RS-485 transceiver is fitted with a decoupling capacitor of 100 nF, with a second footprint for an optional additional capacitor.

Correspondingly labeled test points allow monitoring of the power supply to the board and probe reference to ground.

INPUT/OUTPUT CONNECTIONS

Digital I/O is connected via a screw terminal block on the left of the board, allowing wire connections to equipment or a UART. All boards include connections for data input (DI) and receiver output (RO). The half-duplex and 14-lead SOIC full-duplex evaluation boards also have connections for receiver enable (\overline{RE}) and driver enable (DE). Alternatively, these inputs can be driven by jumper connections to VCC and GND and/or connected together (see Table 2).

Connections to an RS-485 bus are made via a screw terminal block on the right of the board. For the half-duplex board, there are two bus I/O signals, A and B, for noninverting and inverting signals, respectively. For full-duplex boards, there are two input bus signals, A and B, for noninverting and inverting signals, respectively, and two corresponding output signals, Y and Z.

The bus cable may also include a common ground connection or shield. These may also be connected to the screw terminal block on the right of the board.

Test points are available on the board and appropriately labeled for all digital and bus I/O signals.

Table 1. RS-485 Device and Board Cross Reference

Power Supply	Half-Duplex, 8-Lead EVAL-RS485HDEBZ	Full-Duplex, 8-Lead EVAL-RS485FD8EBZ	Full-Duplex, 14-Lead EVAL-RS485FDEBZ
Enhanced ESD, 3.3 V Supply	ADM3072E ADM3075E ADM3078E ADM3483E ADM3485E ADM3486E	ADM3071E ADM3074E ADM3077E ADM3488E ADM3490E	ADM3070E ADM3073E ADM3076E ADM3491E
Enhanced ESD, 5 V Supply	ADM483E ADM485E ADM487E ADM1487E	ADM1490E	ADM1491E
Standard, 3.3 V Supply	ADM3483 ADM3485 ADM3493	ADM3488 ADM3490	ADM3491
Standard, 5 V Supply	ADM1485 ADM1486 ADM4850 ADM4851 ADM4852 ADM4853 ADM483 ADM485	ADM488 ADM488A ADM4854 ADM4855 ADM4856 ADM4857	ADM489 ADM489A

Table 2. Jumper Configuration

Purpose	Half-Duplex Board	Full-Duplex (8-Lead) Board	Full-Duplex (14-Lead) Board	Connection	Description
Select \overline{RE} Input	LK1	N/A	LK2	A B C D	Connects \overline{RE} to VCC (disables receiver output). Connects \overline{RE} to GND (enables receiver output). Allows \overline{RE} input from screw terminal block. Connects \overline{RE} to DE input source.
Select DE Input	LK2	N/A	LK3	A B C	Connects DE to VCC (enables driver outputs). Connects DE to GND (disables driver outputs). Allows DE input from screw terminal block.
Connect RT1	LK3	N/A	N/A	Closed Open	RT1 is connected across A and B. RT1 is disconnected.
Connect RT2	LK4	N/A	N/A	Closed Open	RT2 is connected across A and B. RT2 is disconnected.
Connect A to Y	N/A	LK1	LK5	Closed Open	A is connected to Y. A is not connected to Y.
Connect B to Z	N/A	LK2	LK6	Closed Open	B is connected to Z. B is not connected to Z.

OTHER BOARD COMPONENTS

All three boards include footprints for termination resistors (RT1 and/or RT2) as well as pull-up and pull-down resistors. Termination resistors of 120 Ω are fitted to the board; these may be removed or replaced with a different value resistor as needed.

Full-duplex boards can be evaluated with A connected to Y and B connected to Z (see Table 2). In this configuration, the two termination resistors are in parallel, so the driver can be evaluated with a load equivalent to a bus terminated at both ends.

For the half-duplex board, the same effect is achieved by connecting in two parallel termination resistors using jumpers on the board. Refer to Table 2 for jumper connections.

Biasing Resistors for Bus-Idle Failsafe

Pull-up and pull-down resistors are not fitted by default, but may be required to provide an external biasing network for an idle bus failsafe. These resistors are usually only connected at one position on the bus and selected to provide a minimum differential input voltage (V_{ID}) between A and B of 200 mV. Different resistor values are required depending on whether a 3.3 V or 5 V supply is used, and how much noise margin is required (that is, $V_{ID} > 200$ mV). [ADM3070E](#) to [ADM3078E](#) and [ADM4850](#) to [ADM4857](#) have built-in failsafe for the bus idle condition. For guidelines, refer to [AN-960 Application Note, RS-485/RS-422 Circuit Implementation Guide](#).

EVALUATION WITH APPLICATIONS

Full-Duplex RS-485 Transceiver Loopback

For full-duplex transceivers using the [EVAL-RS485FDEBZ](#) or [EVAL-RS485FD8EBZ](#) boards, a loopback test can be set up by closing LK5 and LK6 or LK1 and LK2, respectively. This test is shown in Figure 4.

A signal generator is connected to DI and this allows verification of the bus signals and the receiver output. Note the jumper positions of LK3 (A) and LK2 (B) for the [EVAL-RS485FDEBZ](#) board. In this configuration, the default termination resistors can be used since both 120 Ω resistors on the board will be connected in parallel by the loop-back, ensuring the test is conducted with a standard RS-485 load of 60 Ω (bus terminated at both ends by 120 Ω).

Half-Duplex RS-485 Transceivers Point-to-Point Test

With two boards, a point-to-point test can be set up. Two half-duplex boards are shown in this configuration in Figure 5. Note the positions of LK1 and LK2 on each board to enable the driver on one board and the receiver on the other board. For [EVAL-RS485FDEBZ](#), these correspond to LK2 and LK3, although in this case, both boards can have the driver and receiver enabled if LK5 and LK6 are open and a four-wire connection is used. For [EVAL-RS485FD8EBZ](#) boards, LK1 and LK2 must be open with a four-wire connection for the point-to-point link.

LK4 has been removed on each [EVAL-RS485HDEBZ](#) board in order to ensure both ends of the bus have only a 120 Ω load. For full-duplex boards with a four-wire connection, the correct termination is on each end of the bus. If [EVAL-RS485FDEBZ](#) boards are used with a two-wire connection and LK5 and LK6 are closed, then one termination resistor needs to be removed from each board.

Connecting to an Existing RS-485 Network

For a two-wire connection to an existing RS-485 network, driver enable (DE) should be disabled (LK2 for [EVAL-RS485HDEBZ](#), LK3 for [EVAL-RS485FDEBZ](#)) by moving to Position B, or else should be controlled externally (Position C) based on received data.

For a four-wire connection using [EVAL-RS485FDEBZ](#), the driver can be permanently enabled by placing LK3 in Position A, if the Y and Z connections are connected only to RS-485 receivers. Otherwise, LK3 should be in Position B or Position C.

For a four-wire connection using [EVAL-RS485FD8EBZ](#), the Y and Z connections should only be connected to other RS-485 receiver inputs, as shown in Figure 6 for a multinode bus.

These full-duplex parts without driver or receiver enable inputs can also typically be used in point-to-point four-wire RS-485 bus connections.

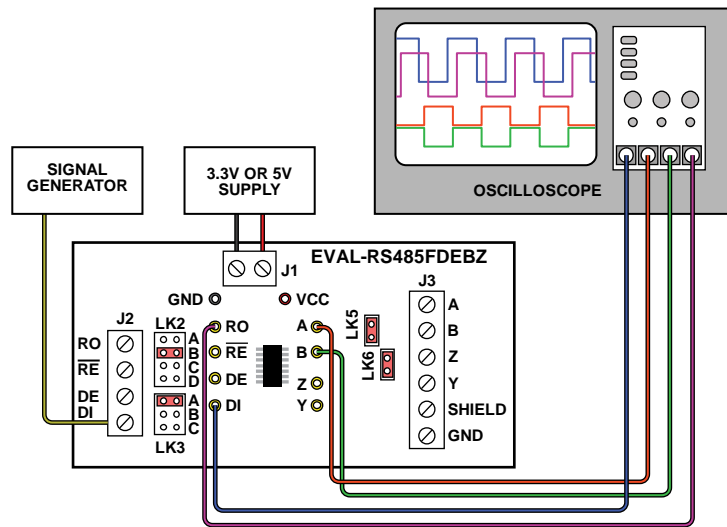

Figure 4. Full-Duplex RS-485 Transceiver Loop Back Test

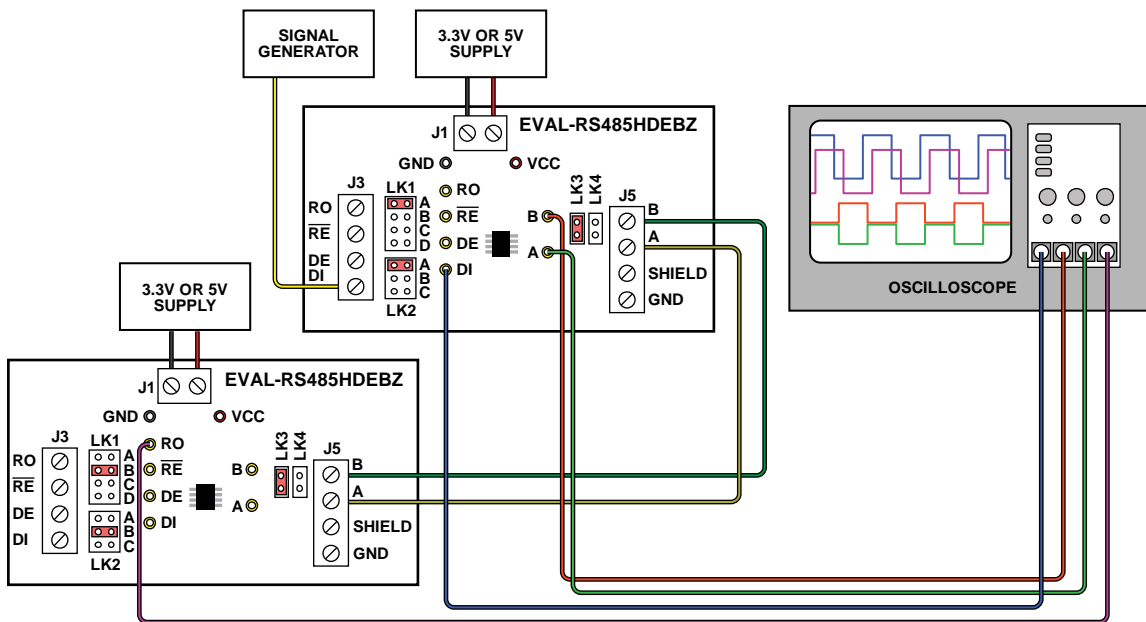
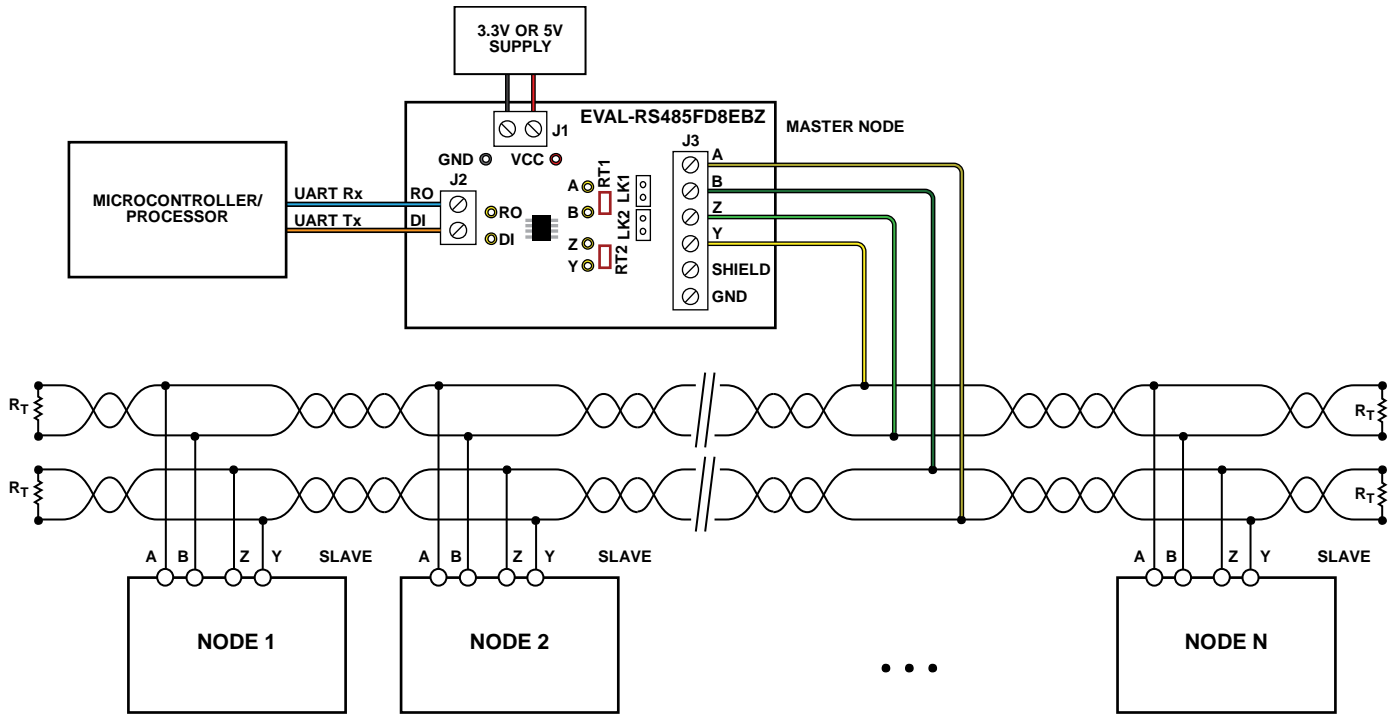

Figure 5. Half-Duplex RS-485 Two Board Point-to-Point Test



- NOTES
1. REMOVE 50Ω TERMINATION RESISTORS FROM EVALUATION BOARD
 2. MAXIMUM NUMBER OF NODES: 32.
 3. R_T IS EQUAL TO THE CHARACTERISTIC IMPEDANCE OF THE CABLE USED.

Figure 6. Full-Duplex (8-Lead SOIC) RS-485 Board Connected to Bus and Control Board

11390-006

EVALUATION BOARD SCHEMATICS AND LAYOUTS

EVAL-RS485HDEBZ

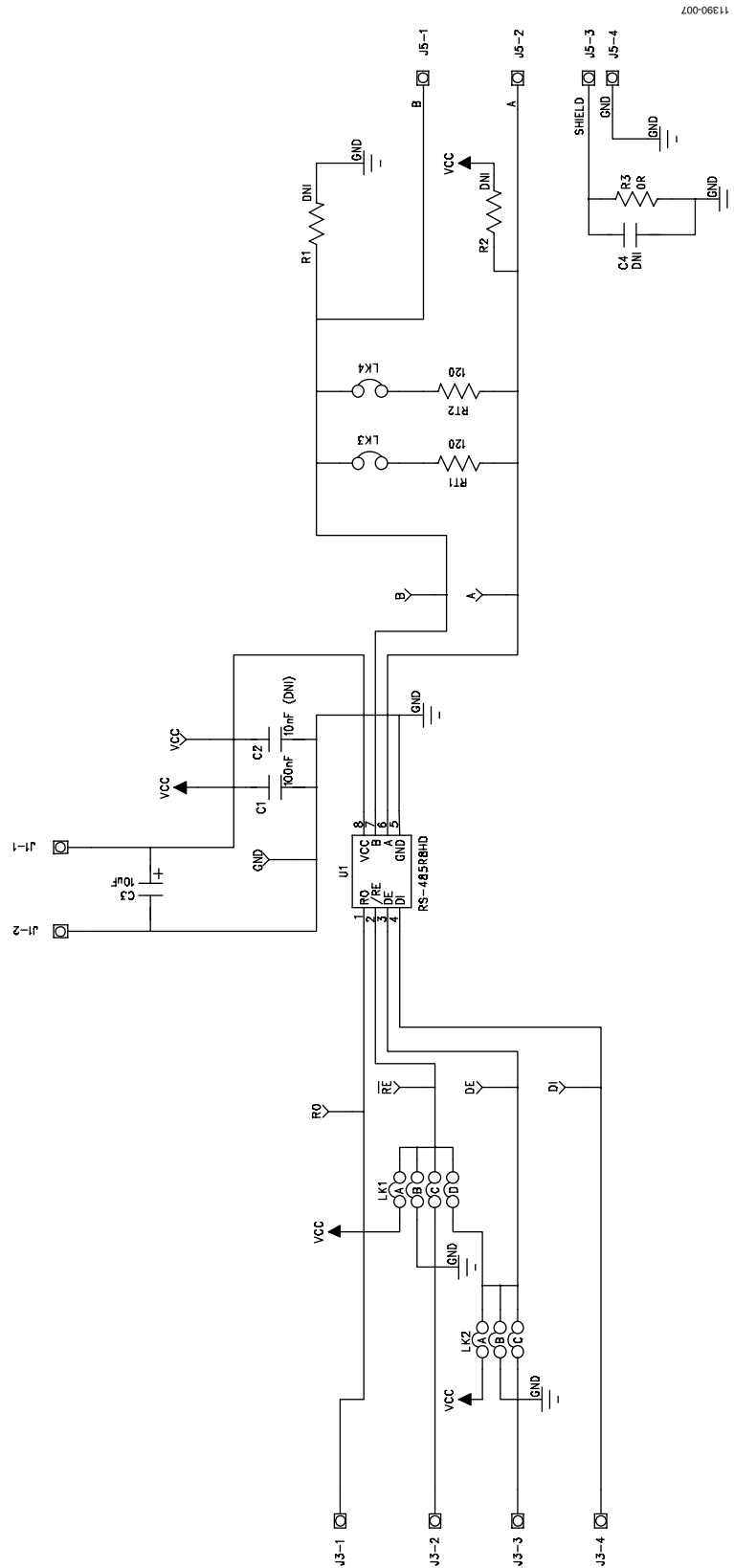
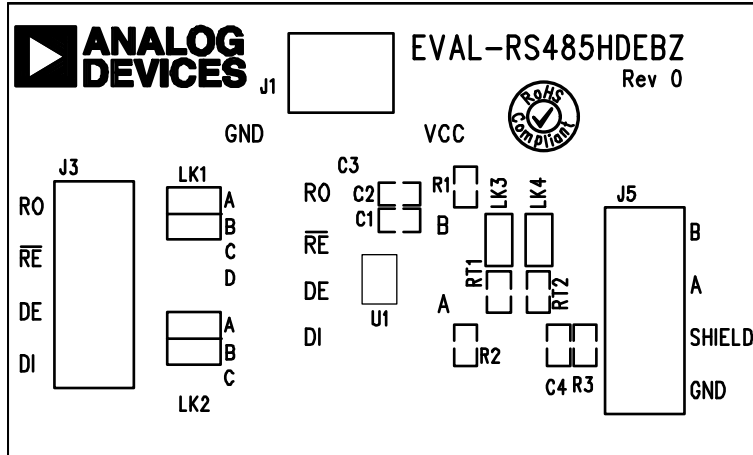
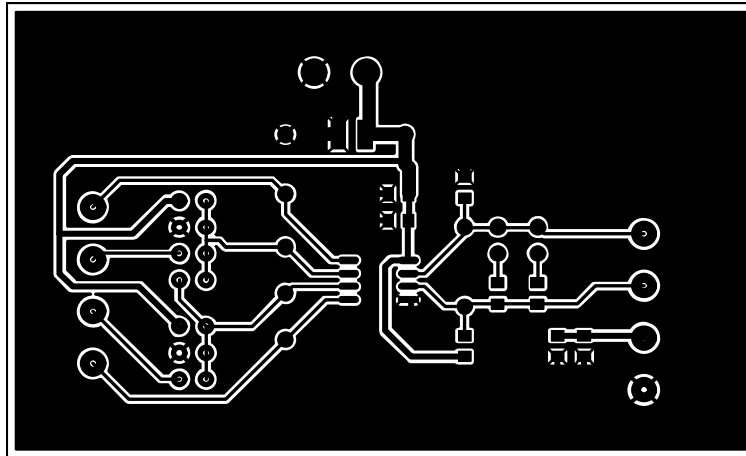

Figure 7. EVAL-RS485HDEBZ Schematic



11390-008

Figure 8. EVAL-RS485HDEBZ Silkscreen



11390-009

Figure 9. EVAL-RS485HDEBZ Component Side

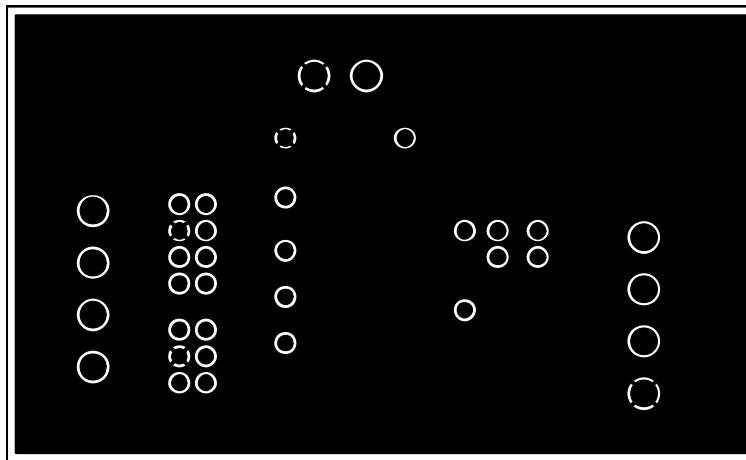

11390-010

Figure 10. EVAL-RS485HDEBZ Solder Side

EVAL-RS485FD8EBZ

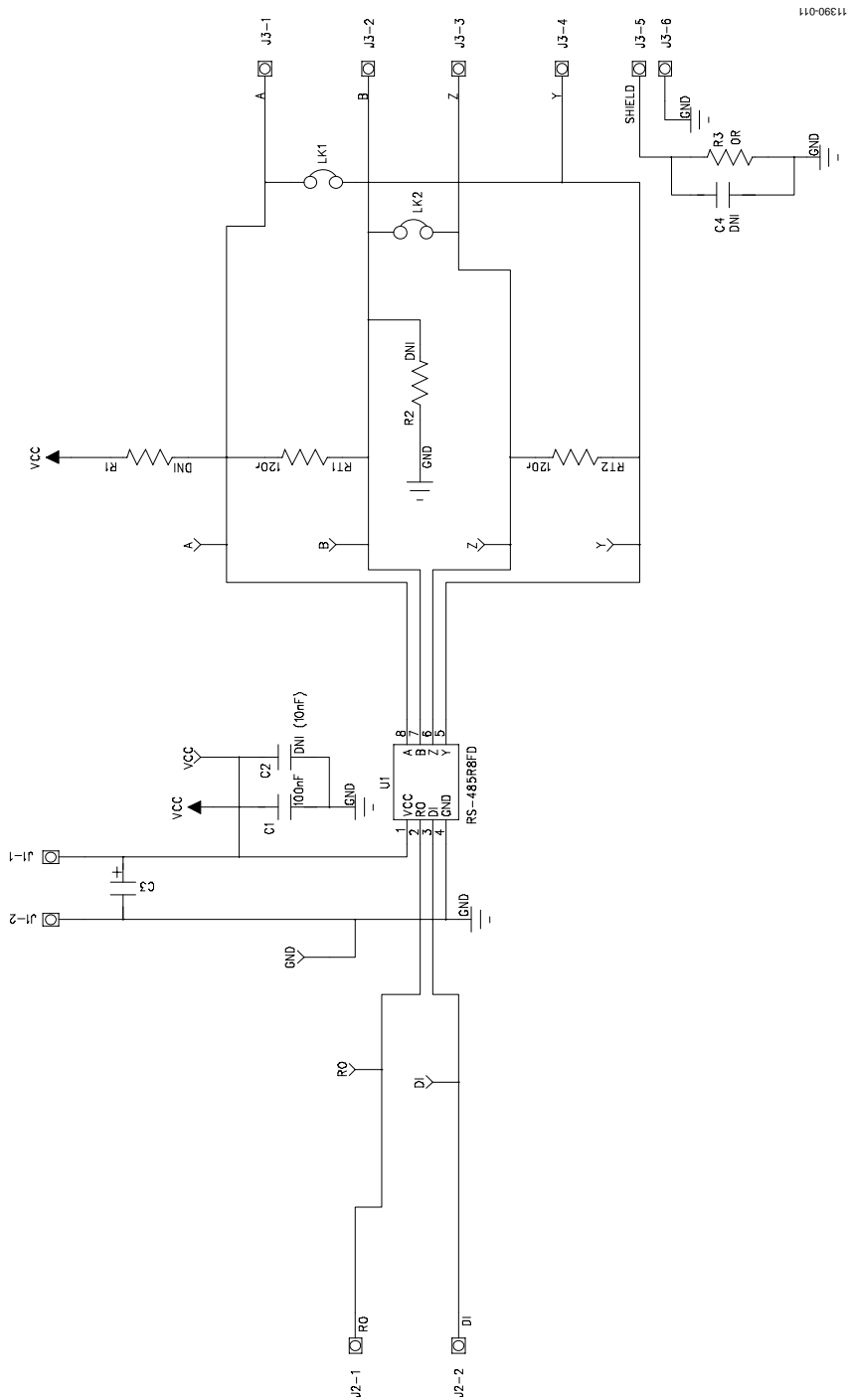

Figure 11. EVAL-RS485FD8EBZ Schematic

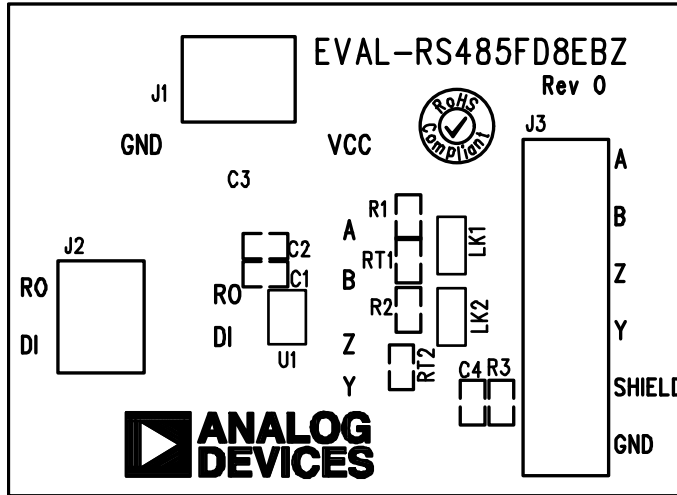

Figure 12. EVAL-RS485FD8EBZ Silkscreen

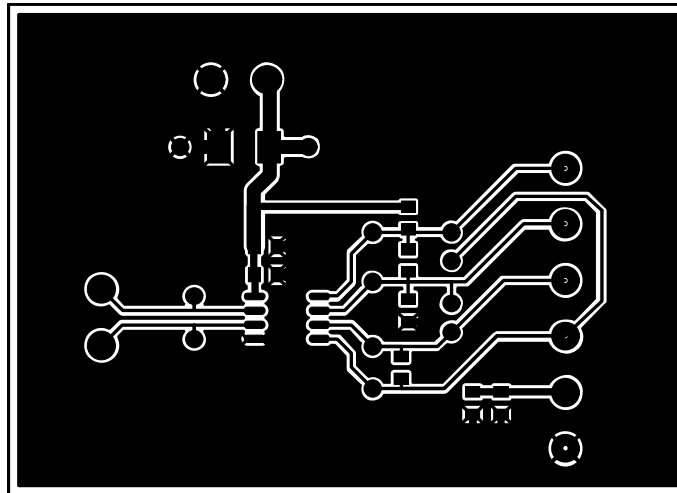

Figure 13. EVAL-RS485FD8EBZ Component Side

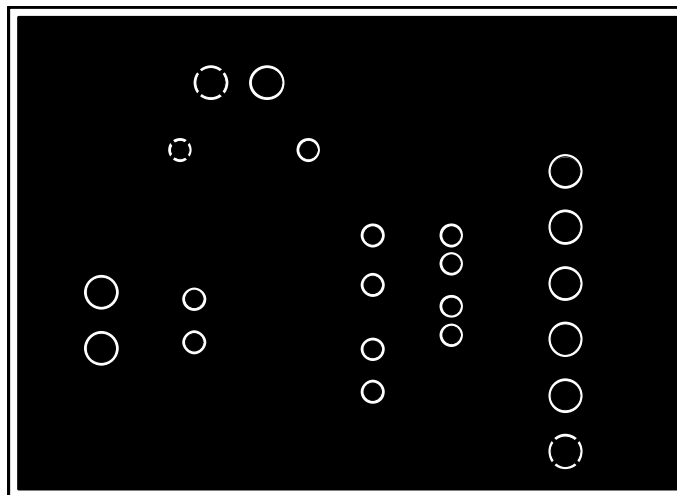

Figure 14. EVAL-RS485FD8EBZ Solder Side

EVAL-RS485FDEBZ

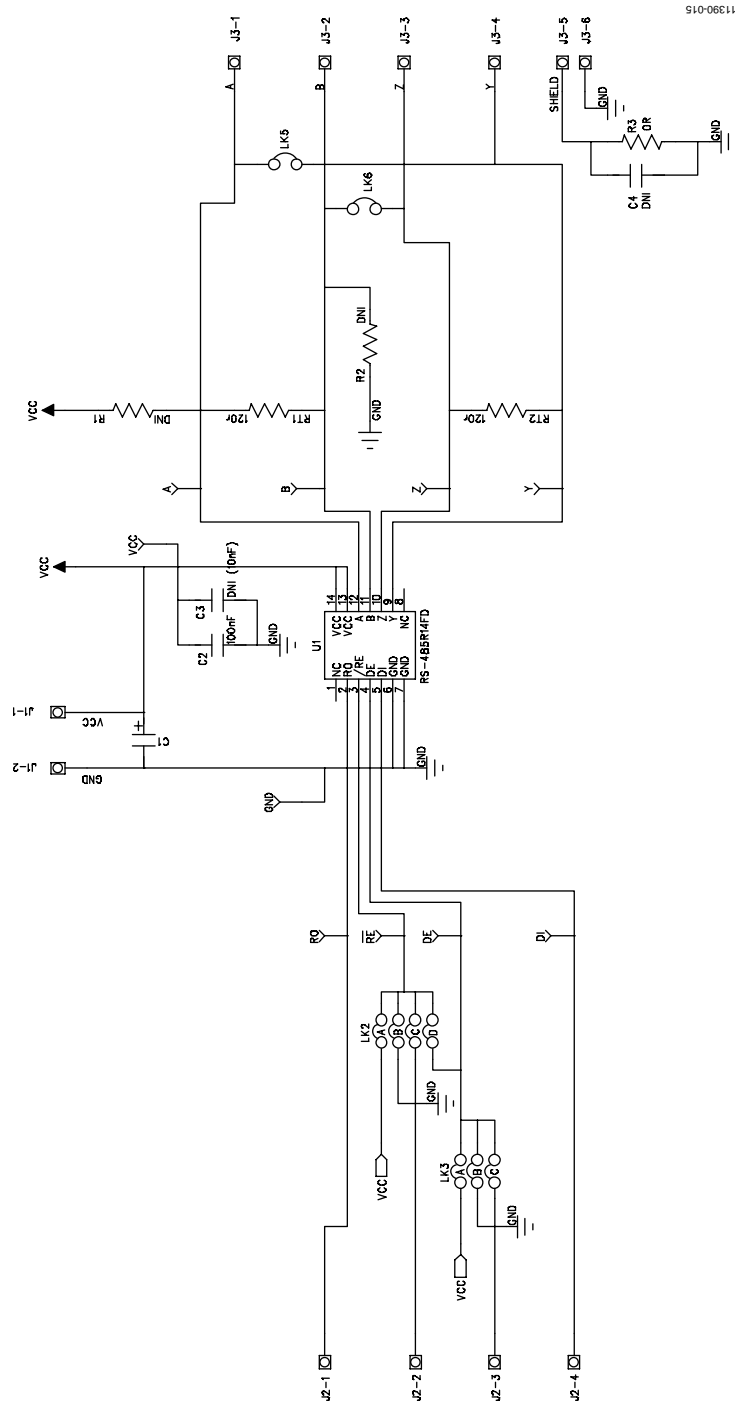
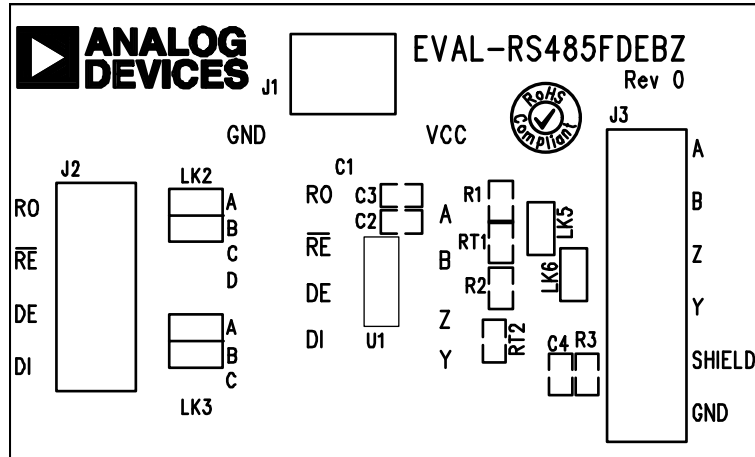
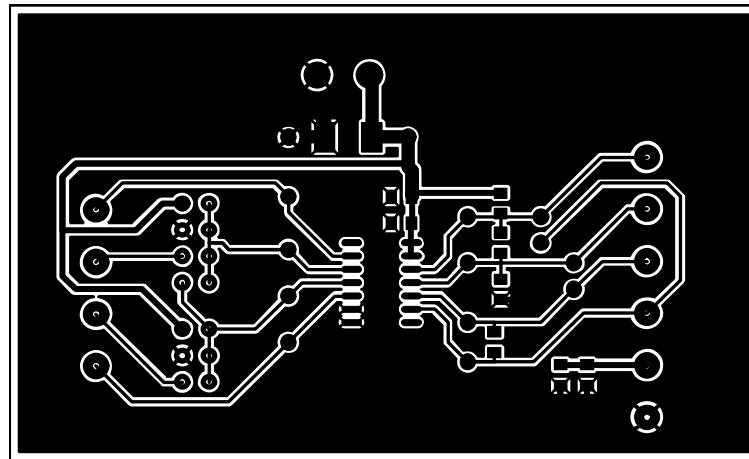

Figure 15. EVAL-RS485FDEBZ Schematic



11390-016

Figure 16. EVAL-RS485FDEBZ Silkscreen



11390-017

Figure 17. EVAL-RS485FDEBZ Component Side

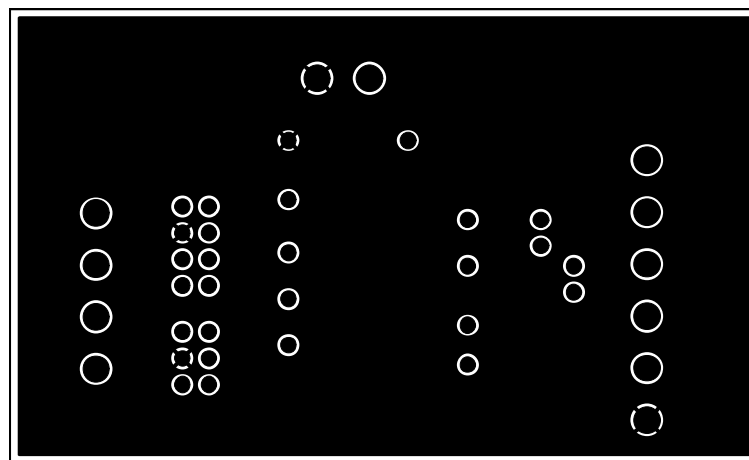

11390-018

Figure 18. EVAL-RS485FDEBZ Solder Side

ORDERING INFORMATION

EVAL-RS485HDEBZ BILL OF MATERIALS

Table 3.

Quantity	Reference Designator	Description	Supplier/Part Number
1	C1	Capacitor, 100 nF, 0805	Multicomp/MCCA000274
2	C2, C4	Not placed/optional	Not applicable
1	C3	Capacitor, 10 μ F, Case B	Kemet/B45196H3106K209
6	A, B, DE, DI, \overline{RE} , RO	Test point, yellow	Vero Technologies/20-313140
1	GND	Test point, black	Vero Technologies/20-2137
1	J1	2-way terminal block	Lumberg/KRM 02
2	J3, J5	4-way terminal block	Lumberg/KRM 04
1	LK1	8-pin (4 \times 2) 0.1" header and shorting block	Harwin/M20-9953646 and Harwin/M7566-05
1	LK2	6-pin (3 \times 2) 0.1" header and shorting block	Harwin/M20-9953646 and Harwin/M7566-05
2	LK3, LK4	Jumper Block, 2 pin, 0.1" spacing	Harwin/M20-9990246 and Harwin/M7566-05
2	R1, R2	Not placed/optional	Not applicable
1	R3	Resistor, 0 Ω , 0805	Vishay Draloric/CRCW08050000Z0EA
2	RT1, RT2	Resistor, 120 Ω , 0805	Multicomp/MC 0.1W 0805 1% 120R
1	U1	8-lead SOIC (not placed)	Analog Devices, Inc./see Table 4
1	VCC	Test point, red	Vero Technologies/20-313137

Table 4. EVAL-RS485HDEBZ Options for U1(Half-Duplex RS-485 Transceivers)

Enhanced ESD, 3.3 V Supply		Enhanced ESD, 5 V Supply	Standard, 3.3 V Supply	Standard, 5 V Supply	
ADM3072E	ADM3483E	ADM483E	ADM3483	ADM1485	ADM4850
ADM3075E	ADM3485E	ADM485E	ADM3485	ADM1486	ADM4851
ADM3078E	ADM3486E	ADM487E	ADM3493	ADM483	ADM4852
		ADM1487E		ADM485	ADM4853

Select the appropriate U1 devices in addition to [EVAL-RS485HDEBZ](#) when ordering. Ensure that the device ordered includes an R in the part number for SOIC devices, for example, [ADM3072EARZ](#).

EVAL-RS485FD8EBZ BILL OF MATERIALS

Table 5.

Quantity	Reference Designator	Description	Supplier/Part Number
1	C1	Capacitor, 100 nF, 0805	Multicomp/MCCA000274
2	C2, C4	Not placed/optional	Not applicable
1	C3	Capacitor, 22 μ F, Case C	AVX/TAJC226K016RNJ
6	A, B, DI, RO, Y, Z	Test point, yellow	Vero Technologies/20-313140
1	GND	Test point, black	Vero Technologies/20-2137
2	J1, J2	2-way terminal block	Lumberg/KRM 02
1	J3	6-way terminal block	Lumberg/KRM 06
2	LK1, LK2	Jumper Block, 2 pin, 0.1" spacing	Harwin/M20-9990246 and Harwin/M7566-05
2	R1, R2	Not placed/optional	Not applicable
1	R3	Resistor, 0 Ω , 0805	Vishay Draloric/CRCW08050000Z0EA
2	RT1, RT2	Resistor, 120 Ω , 0805	Multicomp/MC 0.1W 0805 1% 120R
1	U1	8-lead SOIC (not placed)	Analog Devices/see Table 6
1	VCC	Test point, red	Vero Technologies/20-313137

Table 6. **EVAL-RS485FD8EBZ** Options for U1(Full-Duplex RS-485 Transceivers, 8-Lead SOIC)

Enhanced ESD, 3.3 V Supply		Enhanced ESD, 5 V Supply	Standard, 3.3 V Supply	Standard, 5 V Supply	
ADM3071E	ADM3488E	ADM1490E	ADM3488	ADM4854	ADM4857
ADM3074E	ADM3490E		ADM3490	ADM4855	ADM488
ADM3077E				ADM4856	ADM488A

Select the appropriate U1 devices in addition to [EVAL-RS485FD8EBZ](#) when ordering. Ensure that the device ordered includes an R in the part number for SOIC devices, for example, [ADM3071EARZ](#).

EVAL-RS485FDEBZ BILL OF MATERIALS

Table 7.

Quantity	Reference Designator	Description	Supplier/Part Number
1	C1	Capacitor, 22 μ F, Case C	AVX/TAJC226K016RNJ
1	C2	Capacitor, 100 nF, 0805	Multicomp/MCCA000274
2	C3, C4	Not placed/optional	Not applicable
6	A, B, DE, DI, \overline{RE} , RO, Y, Z	Test point, yellow	Vero Technologies/20-313140
1	GND	Test point, black	Vero Technologies/20-2137
1	J1	2-way terminal block	Lumberg/KRM 02
1	J2	4-way terminal block	Lumberg/KRM 04
1	J3	6-way terminal block	Lumberg/KRM 06
1	LK2	8-pin (4 \times 2) 0.1" header and shorting block	Harwin/M20-9953646 and Harwin/M7566-05
1	LK3	6-pin (3 \times 2) 0.1" header and shorting block	Harwin/M20-9953646 and Harwin/M7566-05
2	LK5, LK6	Jumper Block, 2 pin, 0.1" spacing	Harwin/M20-9990246 and Harwin/M7566-05
2	R1, R2	Not placed/optional	Not applicable
1	R3	Resistor, 0 Ω , 0805	Vishay Draloric/CRCW08050000Z0EA
2	RT1, RT2	Resistor, 120 Ω , 0805	Multicomp/MC 0.1W 0805 1% 120R
1	U1	14-lead SOIC (not placed)	Analog Devices/see Table 8
1	VCC	Test point, red	Vero Technologies/20-313137

Table 8. **EVAL-RS485FDEBZ** Options for U1(Full-Duplex RS-485 Transceivers, 14-Lead SOIC)

Enhanced ESD, 3.3 V Supply		Enhanced ESD, 5 V Supply	Standard, 3.3 V Supply	Standard, 5 V Supply
ADM3070E	ADM3076E	ADM1491E	ADM3491	ADM489
ADM3073E	ADM3491E			ADM489A

Select the appropriate U1 devices in addition to [EVAL-RS485FDEBZ](#) when ordering. Ensure that the device ordered includes an R in the part number for SOIC devices, for example, [ADM3070EARZ](#).

RELATED LINKS

Resource	Description
AN-960	RS-485/RS-422 Circuit Implementation Guide
RS-485/RS-422 Products	RS-485/RS-422 Product Selection

**ESD Caution**

ESD (electrostatic discharge) sensitive device. Charged devices and circuit boards can discharge without detection. Although this product features patented or proprietary protection circuitry, damage may occur on devices subjected to high energy ESD. Therefore, proper ESD precautions should be taken to avoid performance degradation or loss of functionality.

Legal Terms and Conditions

By using the evaluation board discussed herein (together with any tools, components documentation or support materials, the "Evaluation Board"), you are agreeing to be bound by the terms and conditions set forth below ("Agreement") unless you have purchased the Evaluation Board, in which case the Analog Devices Standard Terms and Conditions of Sale shall govern. Do not use the Evaluation Board until you have read and agreed to the Agreement. Your use of the Evaluation Board shall signify your acceptance of the Agreement. This Agreement is made by and between you ("Customer") and Analog Devices, Inc. ("ADI"), with its principal place of business at One Technology Way, Norwood, MA 02062, USA. Subject to the terms and conditions of the Agreement, ADI hereby grants to Customer a free, limited, personal, temporary, non-exclusive, non-sublicensable, non-transferable license to use the Evaluation Board FOR EVALUATION PURPOSES ONLY. Customer understands and agrees that the Evaluation Board is provided for the sole and exclusive purpose referenced above, and agrees not to use the Evaluation Board for any other purpose. Furthermore, the license granted is expressly made subject to the following additional limitations: Customer shall not (i) rent, lease, display, sell, transfer, assign, sublicense, or distribute the Evaluation Board; and (ii) permit any Third Party to access the Evaluation Board. As used herein, the term "Third Party" includes any entity other than ADI, Customer, their employees, affiliates and in-house consultants. The Evaluation Board is NOT sold to Customer; all rights not expressly granted herein, including ownership of the Evaluation Board, are reserved by ADI. CONFIDENTIALITY. This Agreement and the Evaluation Board shall all be considered the confidential and proprietary information of ADI. Customer may not disclose or transfer any portion of the Evaluation Board to any other party for any reason. Upon discontinuation of use of the Evaluation Board or termination of this Agreement, Customer agrees to promptly return the Evaluation Board to ADI. ADDITIONAL RESTRICTIONS. Customer may not disassemble, decompile or reverse engineer chips on the Evaluation Board. Customer shall inform ADI of any occurred damages or any modifications or alterations it makes to the Evaluation Board, including but not limited to soldering or any other activity that affects the material content of the Evaluation Board. Modifications to the Evaluation Board must comply with applicable law, including but not limited to the RoHS Directive. TERMINATION. ADI may terminate this Agreement at any time upon giving written notice to Customer. Customer agrees to return to ADI the Evaluation Board at that time. LIMITATION OF LIABILITY. THE EVALUATION BOARD PROVIDED HEREUNDER IS PROVIDED "AS IS" AND ADI MAKES NO WARRANTIES OR REPRESENTATIONS OF ANY KIND WITH RESPECT TO IT. ADI SPECIFICALLY DISCLAIMS ANY REPRESENTATIONS, ENDORSEMENTS, GUARANTEES, OR WARRANTIES, EXPRESS OR IMPLIED, RELATED TO THE EVALUATION BOARD INCLUDING, BUT NOT LIMITED TO, THE IMPLIED WARRANTY OF MERCHANTABILITY, TITLE, FITNESS FOR A PARTICULAR PURPOSE OR NON-INFRINGEMENT OF INTELLECTUAL PROPERTY RIGHTS. IN NO EVENT WILL ADI AND ITS LICENSORS BE LIABLE FOR ANY INCIDENTAL, SPECIAL, INDIRECT, OR CONSEQUENTIAL DAMAGES RESULTING FROM CUSTOMER'S POSSESSION OR USE OF THE EVALUATION BOARD, INCLUDING BUT NOT LIMITED TO LOST PROFITS, DELAY COSTS, LABOR COSTS OR LOSS OF GOODWILL. ADI'S TOTAL LIABILITY FROM ANY AND ALL CAUSES SHALL BE LIMITED TO THE AMOUNT OF ONE HUNDRED US DOLLARS (\$100.00). EXPORT. Customer agrees that it will not directly or indirectly export the Evaluation Board to another country, and that it will comply with all applicable United States federal laws and regulations relating to exports. GOVERNING LAW. This Agreement shall be governed by and construed in accordance with the substantive laws of the Commonwealth of Massachusetts (excluding conflict of law rules). Any legal action regarding this Agreement will be heard in the state or federal courts having jurisdiction in Suffolk County, Massachusetts, and Customer hereby submits to the personal jurisdiction and venue of such courts. The United Nations Convention on Contracts for the International Sale of Goods shall not apply to this Agreement and is expressly disclaimed.



Стандарт Электрон Связь

Мы молодая и активно развивающаяся компания в области поставок электронных компонентов. Мы поставляем электронные компоненты отечественного и импортного производства напрямую от производителей и с крупнейших складов мира.

Благодаря сотрудничеству с мировыми поставщиками мы осуществляем комплексные и плановые поставки широчайшего спектра электронных компонентов.

Собственная эффективная логистика и склад в обеспечивает надежную поставку продукции в точно указанные сроки по всей России.

Мы осуществляем техническую поддержку нашим клиентам и предпродажную проверку качества продукции. На все поставляемые продукты мы предоставляем гарантию .

Осуществляем поставки продукции под контролем ВП МО РФ на предприятия военно-промышленного комплекса России , а также работаем в рамках 275 ФЗ с открытием отдельных счетов в уполномоченном банке. Система менеджмента качества компании соответствует требованиям ГОСТ ISO 9001.

Минимальные сроки поставки, гибкие цены, неограниченный ассортимент и индивидуальный подход к клиентам являются основой для выстраивания долгосрочного и эффективного сотрудничества с предприятиями радиоэлектронной промышленности, предприятиями ВПК и научно-исследовательскими институтами России.

С нами вы становитесь еще успешнее!

Наши контакты:

Телефон: +7 812 627 14 35

Электронная почта: sales@st-electron.ru

Адрес: 198099, Санкт-Петербург,
Промышленная ул, дом № 19, литера Н,
помещение 100-Н Офис 331