

## Cellular Gateways

### General Description

Don't have an existing network connection where you need it most? ALTA Cellular Gateways allow your Monnit Wireless Sensors to communicate with the iMonnit Online Wireless Sensor Monitoring and Notification System via cellular transmission. They are the perfect solution for remote locations, or where an existing internet connection is not an option.

The ALTA Cellular Gateways are based on the latest Dual-band CDMA or 3G wireless protocols and come integrated with Monnit's wireless access point network (WAN) for use with all Monnit wireless sensors.

The ALTA Cellular Gateway is an advanced all wireless M2M gateway that enables fast time-to-market solutions for a wide range of M2M and partner applications as well. Monnit's ALTA Cellular Gateway is specifically designed to respond to the increasing market need for global technology that accommodates a variety of vertical M2M application segments and remote wireless sensor management solutions.

### Example Applications

- Remote Location Monitoring
- Shipping and Transportation
- Agricultural Monitoring
- Vacant Property Management
- Vacation Home Property Management
- Construction Site Monitoring
- Data Center Monitoring

### ALTA Cellular Gateway Features

- Wireless range of 1,200+ feet through 12+ walls \*
- Frequency Hopping Spread Spectrum (FHSS)
- Improved interference immunity
- Encrypt-RF® Security (Diffie-Hellman Key Exchange + AES-128 CBC for sensor data messages)
- 50,000 sensor message memory
- Over the air updates (future proof)
- True plug & play, no hassles for internet configuration set-up
- No PC required for operation
- Low-cost cellular service packages
- Local status LEDs with transmission and online status indicators
- AC power supply
- Optional 24 hour battery backup in event of power outage

\* Actual range may vary depending on environment.

### Wireless Range Comparison

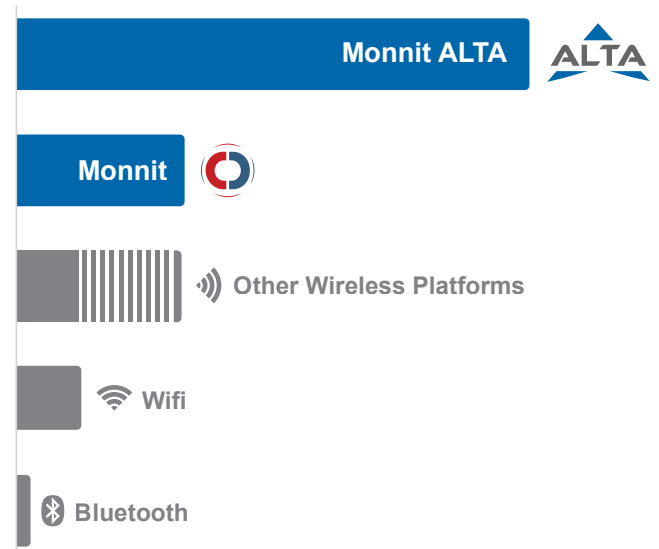

## ALTA CDMA Cellular Gateways

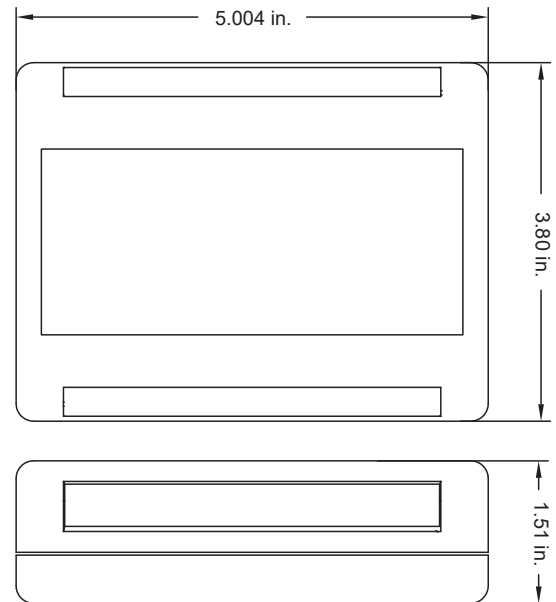

### ALTA CDMA Cellular Gateway Specifications

#### Cellular

|                    |  |
|--------------------|--|
| Carriers Supported | Verizon Wireless, Sprint Wireless, U.S. Cellular     |
| CDMA               | Dual Band CDMA<br>Frequency Range: 800 / 1900 MHz    |
| Antenna            | Articulating Dipole, Connector: SMA, Gain (dBi): 1.5 |

#### Power

|                         |  |
|-------------------------|--|
| Input Power             | 5.5 VDC @ 900 mA                           |
| Optional Battery Backup | Battery Type: Rechargeable Lithium Polymer |
|                         | Battery Duration: Up to 24 hours           |
|                         | Battery Cycle Life: 500 times              |

#### Mechanical

|                |  |
|----------------|--|
| LEDs           | Cellular Status LED, Online Status LED, Sensor Network Status LED  |
| Device Memory: | 50,000 sensor messages<br>(Sensor messages will be stored in the event of Internet outage and transferred when connection is restored) |

#### Enclosure

|            |                        |
|------------|------------------------|
|            | ABS                    |
| Dimensions | 5.004 x 3.8 x 1.51 in. |
| Weight     | 7 ounces               |



#### Environmental

|                       |                            |
|-----------------------|----------------------------|
| Operating Temperature | -10 to +45°C (14 to 113°F) |
| Storage Temperature   | -20 to +60°C (-4 to 140°F) |

#### Wireless

|                |  |
|----------------|--|
| Wireless Range | 1,000+ ft. non-line-of-sight                       |
| Security       | Encrypt-RF™ (256-bit key exchange and AES-128 CTR) |

#### Certifications

|                        |   |   |
|------------------------|---|---|
|                        |   |   |
| Verizon                | FCC: ZTL- G2SC1, FCC: MIVCNN0301  | IC: 9794A-G2SC1 and IC: 4160a-CNN0301   |
| Sprint / U.S. Cellular | FCC: ZTL- G2SC1, FCC: RI7CE910-DUAL   | IC: 9794A-G2SC1 and IC: 5131A-CE910DUAL |

## ALTA 3G Cellular Gateways

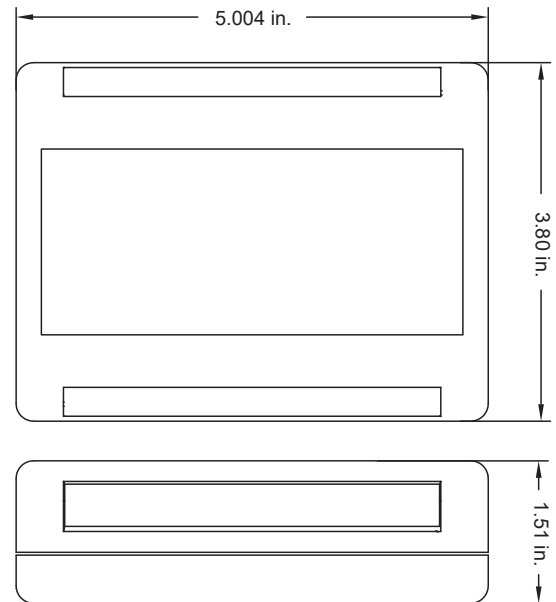

### ALTA 3G Cellular Gateway Specifications

#### Cellular

|                        |  |
|------------------------|--|
| Cellular Technology    | UMTS<br>Frequency Range: 850 / 1700 / 1900 MHz |
| Antenna                | Connector: RP-SMA<br>Gain (dBi): 1.5           |
| SIM Card Compatibility | Mini-SIM (2FF) 25 mm x 15 mm x 0.76 mm         |

#### Power

|                         |  |
|-------------------------|--|
| Input Power             | 5.5 VDC @ 2.5 A                            |
| Optional Battery Backup | Battery Type: Rechargeable Lithium Polymer |
|                         | Battery Duration: Up to 24 hours           |
|                         | Battery Cycle Life: 500 times              |

#### Mechanical

|                |  |
|----------------|--|
| LEDs           | Cellular Status LED, Online Status LED, Sensor Network Status LED  |
| Device Memory: | 50,000 sensor messages<br>(Sensor messages will be stored in the event of Internet outage and transferred when connection is restored) |

#### Enclosure

|            |                        |
|------------|------------------------|
| Dimensions | 5.004 x 3.8 x 1.51 in. |
| Weight     | 7 ounces               |

#### Environmental

|                       |                            |
|-----------------------|----------------------------|
| Operating Temperature | -10 to +45°C (14 to 113°F) |
| Storage Temperature   | -20 to +60°C (-4 to 140°F) |

#### Wireless

|                |  |
|----------------|--|
| Wireless Range | 1,000+ ft. non-line-of-sight   |
| Security       | Encrypt-RF™ (256-bit key exchange and AES-128 CTR)   |
| Certifications | <br>FCC: ZTL- G2SC1, FCC: RI7HE910      IC: 9794A-G2SC1 and IC: 5131A-HE910 |

## ALTA Industrial CDMA Cellular Gateways

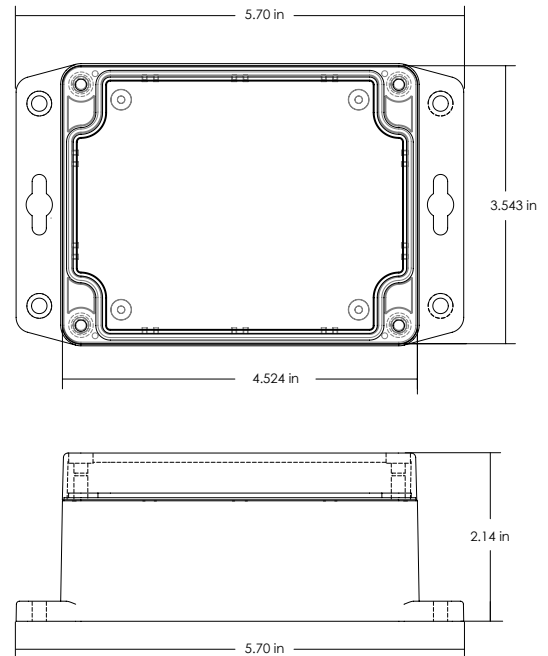

### ALTA Industrial CDMA Cellular Gateway Specifications

#### Cellular

|                    |  |
|--------------------|--|
| Carriers Supported | Verizon Wireless, Sprint Wireless, U.S. Cellular     |
| CDMA               | Dual Band CDMA<br>Frequency Range: 800 / 1900 MHz    |
| Antenna            | Articulating Dipole, Connector: SMA, Gain (dBi): 1.5 |

#### Power

|             |  |
|-------------|--|
| Input Power | 5.5 VDC @ 900 mA (rated for outdoor use) |
|-------------|--|

#### Mechanical

|                  |  |
|------------------|--|
| LEDs             | Cellular Status LED, Online Status LED, Sensor Network Status LED  |
| Device Memory:   | 50,000 sensor messages (messages will be stored in the event of Internet outage and transferred when connection is restored).  |
| <b>Enclosure</b> | NEMA 1, 2, 4, 4x, 12 and 13 rated, sealed and weather proof<br>Monnit's NEMA rated enclosures are constructed for both indoor or outdoor use and protect the enclosed circuitry against the ingress of solid foreign objects like dust as well as the damaging effects of water (rain, sleet, snow, splashing water, and hose directed water). |
| Dimensions       | 5.70 x 3.543 x 2.14 in.  |
| Weight           | 12 ounces  |

#### Environmental

|                       |                            |
|-----------------------|----------------------------|
| Operating Temperature | -10 to +45°C (14 to 113°F) |
| Storage Temperature   | -20 to +60°C (-4 to 140°F) |

#### Wireless

|                |  |
|----------------|--|
| Wireless Range | 1,000+ ft. non-line-of-sight                       |
| Security       | Encrypt-RF™ (256-bit key exchange and AES-128 CTR) |

#### Certifications

|                        |                                     |   |
|------------------------|-------------------------------------|---|
|                        |                                     |   |
| Verizon                | FCC: ZTL- G2SC1, FCC: MIVCNN0301    | IC: 9794A-G2SC1 and IC: 4160a-CNN0301   |
| Sprint / U.S. Cellular | FCC: ZTL- G2SC1, FCC: RI7CE910-DUAL | IC: 9794A-G2SC1 and IC: 5131A-CE910DUAL |

## ALTA Industrial 3G Cellular Gateways

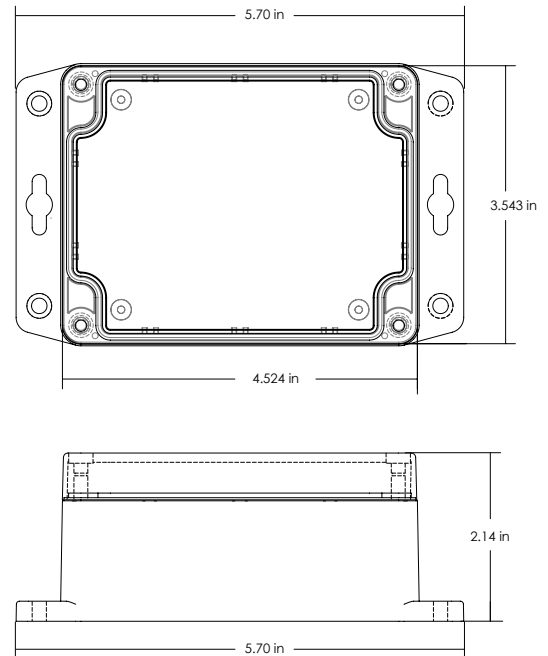

### ALTA Industrial 3G Cellular Gateway Specifications

#### Cellular

|                        |  |
|------------------------|--|
| Cellular Technology    | UMTS<br>Frequency Range: 850 / 1700 / 1900 MHz |
| Antenna                | Connector: RP-SMA<br>Gain (dBi): 1.5           |
| SIM Card Compatibility | Mini-SIM (2FF) 25 mm x 15 mm x 0.76 mm         |

#### Power

|             |   |
|-------------|---|
| Input Power | 5.5 VDC @ 2.5 A (rated for outdoor use) |
|-------------|---|

#### Mechanical

|                  |  |
|------------------|--|
| LEDs             | Cellular Status LED, Online Status LED, Sensor Network Status LED  |
| Device Memory:   | 50,000 sensor messages (messages will be stored in the event of Internet outage and transferred when connection is restored).  |
| <b>Enclosure</b> | NEMA 1, 2, 4, 4x, 12 and 13 rated, sealed and weather proof<br>Monnit's NEMA rated enclosures are constructed for both indoor or outdoor use and protect the enclosed circuitry against the ingress of solid foreign objects like dust as well as the damaging effects of water (rain, sleet, snow, splashing water, and hose directed water). |
| Dimensions       | 5.70 x 3.543 x 2.14 in.  |
| Weight           | 12 ounces  |

#### Environmental

|                       |                            |
|-----------------------|----------------------------|
| Operating Temperature | -10 to +45°C (14 to 113°F) |
| Storage Temperature   | -20 to +60°C (-4 to 140°F) |

#### Wireless

|                |  |
|----------------|--|
| Wireless Range | 1,000+ ft. non-line-of-sight                       |
| Security       | Encrypt-RF™ (256-bit key exchange and AES-128 CTR) |

|                |   |
|----------------|---|
| Certifications | <br>FCC: ZTL- G2SC1, FCC: RI7HE910   IC: 9794A-G2SC1 and IC: 5131A-HE910 |
|----------------|---|

## Commercial Grade Cellular Gateways:

Monnit commercial grade cellular gateways are designed for applications in ordinary environments (normal room temperature, humidity and atmospheric pressure). Do not use these gateways under the following conditions as these factors can deteriorate the product characteristics and cause failures and burn-out.

- Corrosive gas or deoxidizing gas - chlorine gas, hydrogen sulfide gas, ammonia gas, sulfuric acid gas, nitric oxides gas, etc.).
- Volatile or flammable gas.
- Dusty conditions.
- Under low or high pressure.
- Wet or excessively humid locations.
- Places with salt water, oils chemical liquids or organic solvents.
- Where there are excessively strong vibrations.
- Other places where similar hazardous conditions exist.

Use these product within the specified temperature range. Higher temperature may cause deterioration of the characteristics or the material quality.

## Industrial Grade Cellular Gateways - Type 1, 2, 4, 4X, 12 and 13 NEMA Rated Enclosure:

Monnit's Industrial cellular gateways are enclosed in reliable, weatherproof NEMA rated enclosures. Our NEMA rated enclosures are constructed for both indoor or outdoor use and protect the sensor circuitry against the ingress of solid foreign objects like dust as well as the damaging effects of water (rain, sleet, snow, splashing water, and hose directed water).

- Safe from falling dirt.
- Protects against wind blown dust.
- Protects against rain, sleet, snow, splashing water, and hose directed water
- Increased level of corrosion resistance
- Will remain undamaged by ice formation on the enclosure



For more information about our products or to place an order, please contact our sales department at 801-561-5555.

Visit us on the web at [www.monnit.com](http://www.monnit.com).

Monnit Corporation  
3400 South West Temple  
South Salt Lake, UT 84115  
801-561-5555  
[www.monnit.com](http://www.monnit.com)



## Стандарт Электрон Связь

Мы молодая и активно развивающаяся компания в области поставок электронных компонентов. Мы поставляем электронные компоненты отечественного и импортного производства напрямую от производителей и с крупнейших складов мира.

Благодаря сотрудничеству с мировыми поставщиками мы осуществляем комплексные и плановые поставки широчайшего спектра электронных компонентов.

Собственная эффективная логистика и склад в обеспечивает надежную поставку продукции в точно указанные сроки по всей России.

Мы осуществляем техническую поддержку нашим клиентам и предпродажную проверку качества продукции. На все поставляемые продукты мы предоставляем гарантию .

Осуществляем поставки продукции под контролем ВП МО РФ на предприятия военно-промышленного комплекса России , а также работаем в рамках 275 ФЗ с открытием отдельных счетов в уполномоченном банке. Система менеджмента качества компании соответствует требованиям ГОСТ ISO 9001.

Минимальные сроки поставки, гибкие цены, неограниченный ассортимент и индивидуальный подход к клиентам являются основой для выстраивания долгосрочного и эффективного сотрудничества с предприятиями радиоэлектронной промышленности, предприятиями ВПК и научно-исследовательскими институтами России.

С нами вы становитесь еще успешнее!

### Наши контакты:

**Телефон:** +7 812 627 14 35

**Электронная почта:** [sales@st-electron.ru](mailto:sales@st-electron.ru)

**Адрес:** 198099, Санкт-Петербург,  
Промышленная ул, дом № 19, литера Н,  
помещение 100-Н Офис 331